

## Setup

### Power

AC/DC power input: requires an AC/DC power adapter (included).

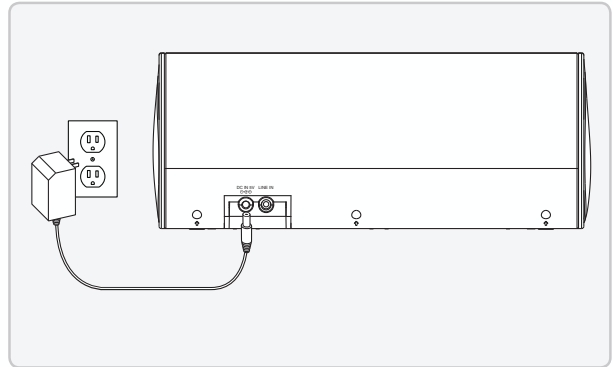

### Functions of the Indicator lights

Status	Power Indicator	Pairing Indicator
Power Off	Solid red light	No light
Power On	No light	Flashing blue light
Ready to Pair	Flashing green light	Flashing blue light
Bluetooth Connected	Solid green light	Flashing blue light

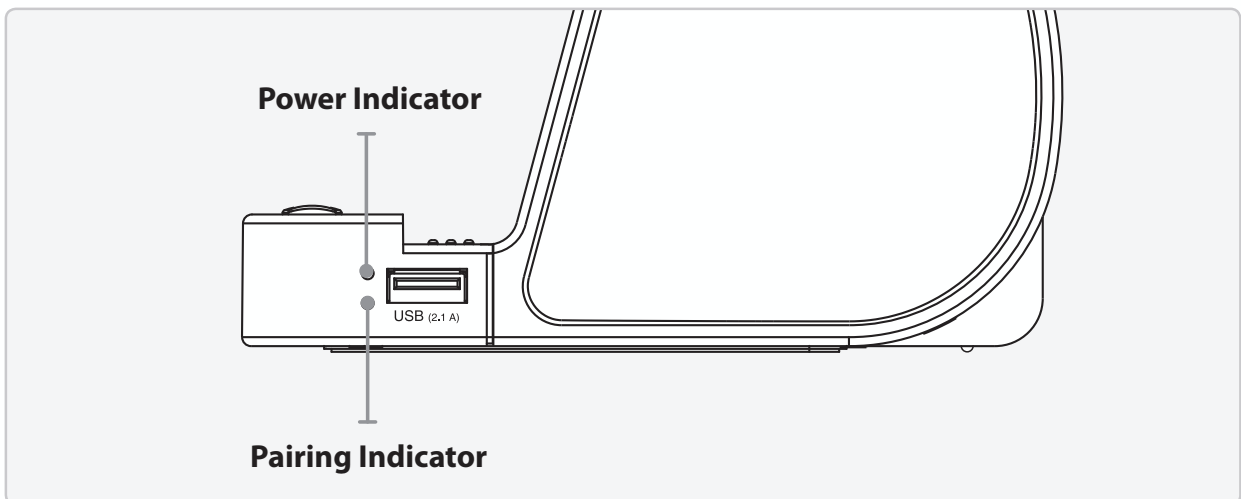

## Bluetooth Setup

### Pairing a Bluetooth Device

1. Power on the unit using the **Power** button.
2. Press and hold the **Pair** button until the LED indicators alternate flashing green and blue.

*When pairing, remain within 3 feet of the unit.*

3. Select the "ISB311B" in your Bluetooth settings to pair.

*If your device requests a password, enter the default password "0000".*

*Refer to the user's manual for your specific device for instructions on pairing and connecting Bluetooth devices.*

4. When device has been successfully paired, a beep will sound from the unit.

*After initial pairing, the unit will stay paired unless unpaired manually by the user or erased due to a reset of the device. Refer to the user's manual for your specific device for instructions on disconnecting or unpairing Bluetooth devices.*

## Using Bluetooth and Charging

### Playing Audio Wirelessly

1. Follow the instructions for [Pairing a Bluetooth Device](#).
2. Use the native controls on the connected Bluetooth Device to select a track.
3. To play, pause or skip the selected track, use the native controls on the connected Bluetooth Device or press the **Pair/Play/Pause** or **Skip** buttons.
4. Audio played through the connected Bluetooth device will now be heard through the speakers.

### Using the Speakerphone

1. Follow the instructions in [Pairing a Bluetooth Device](#).
2. When a call is received, a ringtone will sound through the speakers.
3. Press the **Speakerphone** button to accept the call or accept the call with the native controls on the connected device.
4. To reject the call, press and hold the **Speakerphone** button over 3 seconds or reject the call using the native controls on the connected device.
5. The incoming call received through the device will now be heard through the speakers.
6. To end the call, press the **Speakerphone** button or end the call using the native controls on the connected device.

### Charging a Device

1. Power on the unit using the **Power** button.
2. Using a USB charging cable (included), connect one end to the device and the other to one of the two **USB Ports** on the unit.

*Refer to the user's manual for your specific device for manufacturers required charging amperage before charging your device.*

3. The device will now charge.

*Up to two devices can be charged at once.*

*Note: When using an iPod, iPhone or iPad, use the USB cable that was included with your device.*

## 3.5 mm Audio Input

### Using the 3.5mm Audio Input

1. Plug one end of a 3.5 mm audio input cable (not included) into the **3.5 mm Audio Input** on the unit.
2. Plug the other end of the cable into the audio output/headphone output on an MP3 Player or other audio source.
3. Press the **Power** button to power the unit on.
4. Audio played through the connected device will now be heard through the speakers.

*Use the native controls on the connected Bluetooth Device to select a track.*

## Company Information

### International Support

To download this User's Guide in English, Spanish, or French, visit the support section at [www.ilive.net](http://www.ilive.net).

Para transferir esta guía de usuario en inglés, español, o francés, visite la sección de la ayuda en [www.ilive.net](http://www.ilive.net).

Pour télécharger ce guide de l'utilisateur en anglais, espagnol, ou français, visitez la section de soutien chez [www.ilive.net](http://www.ilive.net).

### Contact Information

**Phone:** 1-888-999-4215

**Email:** [customerservice@ilive.net](mailto:customerservice@ilive.net)

**Parts Email:** [partsinfo@dpi-global.com](mailto:partsinfo@dpi-global.com)

**Website:** [www.ilive.net](http://www.ilive.net)

### Green Initiative



#### Environmental Commitment to 'Protect for Today and Sustain for Tomorrow'

2009 marked the official launch of DPI, Inc.'s corporate campaign for a greener and cleaner world. DPI is building upon environmental initiatives introduced at all of their facilities to help formulate and sustain significant and important conservation efforts within its manufacturing and marketing communities. In addition to targeting and selecting energy efficient product features, and structuring 'green office' procedures, other initial program efforts include:

- Reduction of all packaging sizes
- Recyclable plastics for clamshell packages, with a plan to eventually replace plastic with recyclable paper
- Recycled fiber board in place of the polyfoam in packing boxes
- Recycled plastics in place of the virgin material in product construction