FCC Test Report

Report No.: AGC03158150801FE03

FCC ID : ZJEOM4750W
APPLICATION PURPOSE : Original Equipment
PRODUCT DESIGNATION : 2.4GHz Wireless Mouse
BRAND NAME : N/A
MODEL NAME : OM4750W, OM6750W, ST-266, ST-267, ST-289, ST-299
CLIENT : Shenzhen Star Sources Electronic Technology Co., Limited
DATE OF ISSUE : Aug.22, 2015
STANDARD(S) : FCC Part 15 Rules
TEST PROCEDURE(S)
REPORT VERSION : V1.0

Attestation of Global Compliance (Shenzhen) Co., Ltd



CAUTION:

This report shall not be reproduced except in full without the written permission of the test laboratory and shall not be quoted out of context.



Report Revise Record

Report Version	Revise Time	Issued Date	Valid Version	Notes
V1.0	/	Aug.22, 2015	Valid	Original Report

TABLE OF CONTENTS

1. VERIFICATION OF CONFORMITY	4
2. GENERAL INFORMATION	5
2.1. PRODUCT DESCRIPTION	5
2.2. TABLE OF CARRIER FREQUENCY.....	6
3. MEASUREMENT UNCERTAINTY	7
4. DESCRIPTION OF TEST MODES	7
5. SYSTEM TEST CONFIGURATION	8
5.1. CONFIGURATION OF EUT SYSTEM.....	8
5.2. EQUIPMENT USED IN EUT SYSTEM.....	8
5.3. SUMMARY OF TEST RESULTS.....	8
6. TEST FACILITY	9
7. RADIATED EMISSION	10
7.1 TEST LIMIT	10
7.2. MEASUREMENT PROCEDURE	11
7.3. TEST SETUP	13
7.4. TEST RESULT	15
8. BAND EDGE EMISSION	20
8.1. MEASUREMENT PROCEDURE	20
8.2 TEST SETUP	20
8.3 RADIATED TEST RESULT	21
9. 20DB BANDWIDTH	25
9.1. MEASUREMENT PROCEDURE	25
9.2. TEST SET-UP (BLOCK DIAGRAM OF CONFIGURATION)	25
9.3. MEASUREMENT RESULTS	25
APPENDIX A: PHOTOGRAPHS OF TEST SETUP	28
APPENDIX B: PHOTOGRAPHS OF EUT	29

1. VERIFICATION OF CONFORMITY

Applicant	Shenzhen Star Sources Electronic Technology Co., Limited
Address	RM2001 MeiLan Business Center, intersection between the road of XiXiang and Qianjin, BaoAn District, Shenzhen, China Postcode: 518100
Manufacturer	Shenzhen Star Sources Electronic Technology Co., Limited
Address	RM2001 MeiLan Business Center, intersection between the road of XiXiang and Qianjin, BaoAn District, Shenzhen, China Postcode: 518100
Product Designation	2.4GHz Wireless Mouse
Brand Name	N/A
Test Model	OM4750W
Series Model	OM6750W, ST-266, ST-267, ST-289, ST-299
Difference description	All the same except for the model name and appearance Color.
Date of test	Aug.18, 2015 to Aug.21, 2015
Deviation	None
Condition of Test Sample	Normal
Report Template	AGCRT-US-BR/RF

We hereby certify that:

The above equipment was tested by Dongguan Precise Testing Service Co., Ltd. The test data, data evaluation, test procedures, and equipment configurations shown in this report were made in accordance with the procedures given in ANSI C63.4 (2009) and the energy emitted by the sample EUT tested as described in this report is in compliance with radiated emission limits of FCC Rules Part 15.249.

Tested by

Max Zhang

Max Zhang(Zhang Yi) Aug.22, 2015

Reviewed by

Rock Huang

Rock Huang(Huang Dinglue) Aug.22, 2015

Approved by

Solger Zhang

Solger Zhang(Zhang Hongyi) Aug.22, 2015
Authorized Officer

2. GENERAL INFORMATION

2.1. PRODUCT DESCRIPTION

A major technical description of EUT is described as following

Operation Frequency	2.409 GHz to 2.476GHz
Maximum field strength	80.9dBuV/m@3m(AV)
Modulation	GFSK
Number of channels	8
Antenna Gain	0dBi
Antenna Designation	PCB Antenna (Met 15.203 Antenna requirement)
Hardware Version	N/A
Software Version	N/A
Power Supply	DC3V by battery

2.2. TABLE OF CARRIER FREQUENCY

Channel	Frequency (GHz)	Channel	Frequency (GHz)
01	2.409	05	2.445
02	2.417	06	2.455
03	2.426	07	2.460
04	2.440	08	2.476

3. MEASUREMENT UNCERTAINTY

The reported uncertainty of measurement $y \pm U$ where expanded uncertainty U is based on a standard uncertainty multiplied by a coverage factor of $k=2$ providing a level of confidence of approximately 95 %

No.	Item	Uncertainty
1	Conducted Emission Test	$\pm 3.18\text{dB}$
2	All emissions, radiated	$\pm 3.91\text{dB}$
3	Temperature	$\pm 0.5^\circ\text{C}$
4	Humidity	$\pm 2\%$

4. DESCRIPTION OF TEST MODES

NO.	TEST MODE DESCRIPTION
1	Low channel TX in GFSK modulation
2	Middle channel TX in GFSK modulation
3	High channel TX in GFSK modulation
4	TX OFF

Note:

1. All the test modes can be supply by battery, only the result of the worst case was recorded in the report, if no other cases.
2. For Radiated Emission, 3axis were chosen for testing for each applicable mode.

5. SYSTEM TEST CONFIGURATION

5.1. CONFIGURATION OF EUT SYSTEM

Configure :

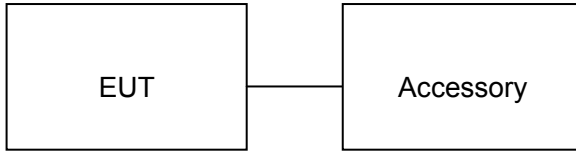

5.2. EQUIPMENT USED IN EUT SYSTEM

Item	Equipment	Model No.	ID or Specification	Remark
1	2.4GHz Wireless Mouse	N/A	OM4750W	EUT

5.3. SUMMARY OF TEST RESULTS

FCC RULES	DESCRIPTION OF TEST	RESULT
§15.249	Radiated Emission	Compliant
§15.249	Band Edges	Compliant
§15.215	20dB bandwidth	Compliant

6. TEST FACILITY

Site	Dongguan Precise Testing Service Co., Ltd.
Location	Building D, Baoding Technology Park, Guangming Road2, Dongcheng District, Dongguan, Guangdong, China.
FCC Registration No.	371540
Description	The test site is constructed and calibrated to meet the FCC requirements in documents ANSI C63.4:2009.

ALL TEST EQUIPMENT LIST

Radiated Emission Test Site					
Name of Equipment	Manufacturer	Model Number	Serial Number	Last Calibration	Due Calibration
EMI Test Receiver	Rohde & Schwarz	ESCI	101417	July 4, 2015	July 3, 2016
Trilog Broadband Antenna (25M-1GHz)	SCHWARZBECK	VULB9160	9160-3355	July 4, 2015	July 3, 2016
Signal Amplifier	SCHWARZBECK	BBV 9475	9745-0013	July 4, 2015	July 3, 2016
RF Cable	SCHWARZBECK	AK9515E	96221	July 4, 2015	July 3, 2016
3m Anechoic Chamber	CHENGYU	966	PTS-001	June 6, 2015	June 5, 2016
MULTI-DEVICE Positioning Controller	Max-Full	MF-7802	MF780208339	N/A	N/A
Active loop antenna (9K-30MHz)	Schwarzbeck	FMZB1519	1519-038	June 6, 2015	June 5, 2016
Spectrum analyzer	Agilent	E4407B	MY46185649	June 6, 2015	June 5, 2016
Horn Antenna (1G-18GHz)	SCHWARZBECK	BBHA9120D	9120D-1246	June 6, 2015	June 5, 2016
Horn Ant (18G-40GHz)	Schwarzbeck	BBHA 9170	9170-181	June 6, 2015	June 5, 2016

7. RADIATED EMISSION

7.1 TEST LIMIT

Standard FCC15.249

Fundamental Frequency	Field Strength of Fundamental (millivolts/meter)	Field Strength of Harmonics (microvolts/meter)
900-928MHz	50	500
2400-2483.5MHz	50	500
5725-5875MHz	50	500
24.0-24.25GHz	250	2500

Standard FCC 15.209

Frequency (MHz)	Distance Meters	Field Strengths Limit	
		V/m	dB(μV)/m
0.009 ~ 0.490	300	2400/F(kHz)	---
0.490 ~ 1.705	30	24000/F(kHz)	---
1.705 ~ 30	30	30	---
30 ~ 88	3	100	40.0
88 ~ 216	3	150	43.5
216 ~ 960	3	200	46.0
960 ~ 1000	3	500	54.0
Above 1000	3	Other:74.0 dB(μV)/m (Peak) 54.0 dB(μV)/m (Average)	

Remark (1) Emission level dB $V = 20 \log$ Emission level V/m
 (2) The smaller limit shall apply at the cross point between two frequency bands.
 (3) Distance is the distance in meters between the measuring instrument, antenna and the closest point of any part of the device or system.

7.2. MEASUREMENT PROCEDURE

1. Configure the EUT according to ANSI C63.4. The EUT was placed on the top of the turntable 0.8 meter above ground. The phase center of the receiving antenna mounted on the top of a height-variable antenna tower was placed 3 meters far away from the turntable.
2. Power on the EUT and all the supporting units. The turntable was rotated by 360 degrees to determine the position of the highest radiation.
3. The height of the broadband receiving antenna was varied between one meter and four meters above ground to find the maximum emissions field strength of both horizontal and vertical polarization.
4. For each suspected emissions, the antenna tower was scan (from 1 M to 4 M) and then the turntable was rotated (from 0 degree to 360 degrees) to find the maximum reading.
5. Set the test-receiver system to Peak or CISPR quasi-peak Detect Function with specified bandwidth under Maximum Hold Mode.
6. For emissions above 1GHz, use 1MHz VBW and RBW for peak reading. Then 1MHz RBW and 10Hz VBW for average reading in spectrum analyzer.
7. When the radiated emissions limits are expressed in terms of the average value of the emissions, and pulsed operation is employed, the measurement field strength shall be determined by averaging over one complete pulse train, including blanking intervals, as long as the pulse train does not exceed 0.1 seconds. As an alternative (provided the transmitter operates for longer than 0.1 seconds) or in cases where the pulse train exceeds 0.1 seconds, the measured field strength shall be determined from the average absolute voltage during a 0.1 second interval during which the field strength is at its maximum values.
8. If the emissions level of the EUT in peak mode was 3 dB lower than the average limit specified, then testing will be stopped and peak values of EUT will be reported, otherwise, the emissions which do not have 3 dB margin will be repeated one by one using the quasi-peak method for below 1GHz.
9. For testing above 1GHz, the emissions level of the EUT in peak mode was lower than average limit (that means the emissions level in peak mode also complies with the limit in average mode), then testing will be stopped and peak values of EUT will be reported, otherwise, the emissions will be measured in average mode again and reported.
10. In case the emission is lower than 30MHz, loop antenna has to be used for measurement and the recorded data should be QP measured by receiver. High - Low scan is not required in this case.

The following table is the setting of spectrum analyzer and receiver.

Spectrum Parameter	Setting
Start ~Stop Frequency	9KHz~150KHz/RB 200Hz for QP
Start ~Stop Frequency	150KHz~30MHz/RB 9KHz for QP
Start ~Stop Frequency	30MHz~1000MHz/RB 120KHz for QP
Start ~Stop Frequency	1GHz~26.5GHz 1MHz/1MHz for Peak, 1MHz/10Hz for Average

Receiver Parameter	Setting
Start ~Stop Frequency	9KHz~150KHz/RB 200Hz for QP
Start ~Stop Frequency	150KHz~30MHz/RB 9KHz for QP
Start ~Stop Frequency	30MHz~1000MHz/RB 120KHz for QP

7.3. TEST SETUP

Radiated Emission Test-Setup Frequency Below 30MHz

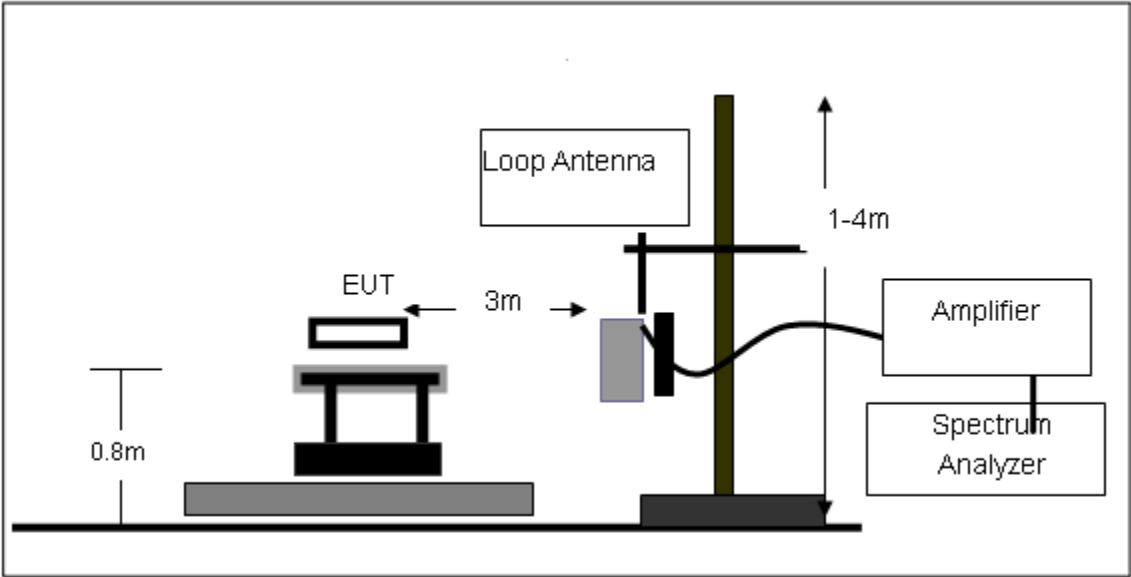

RADIATED EMISSION TEST SETUP 30MHz-1000MHz

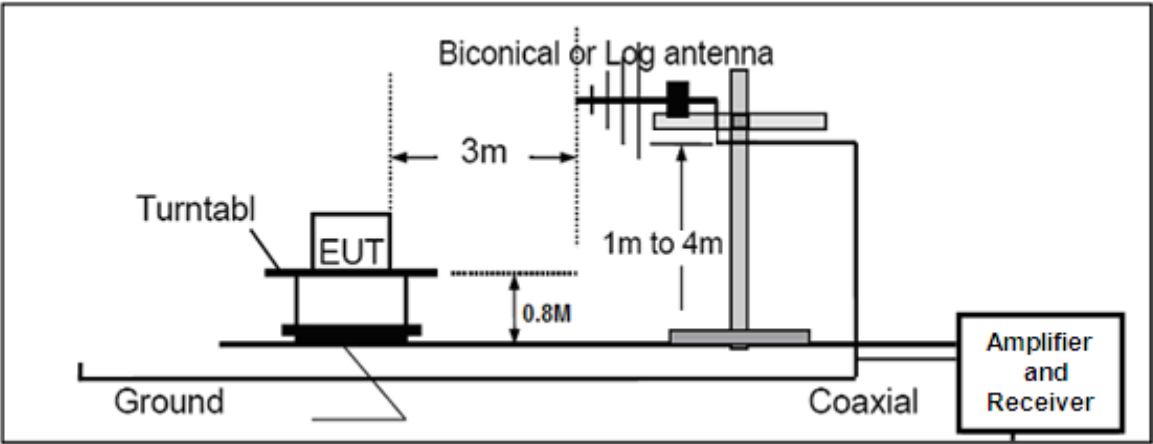

RADIATED EMISSION TEST SETUP ABOVE 1000MHz

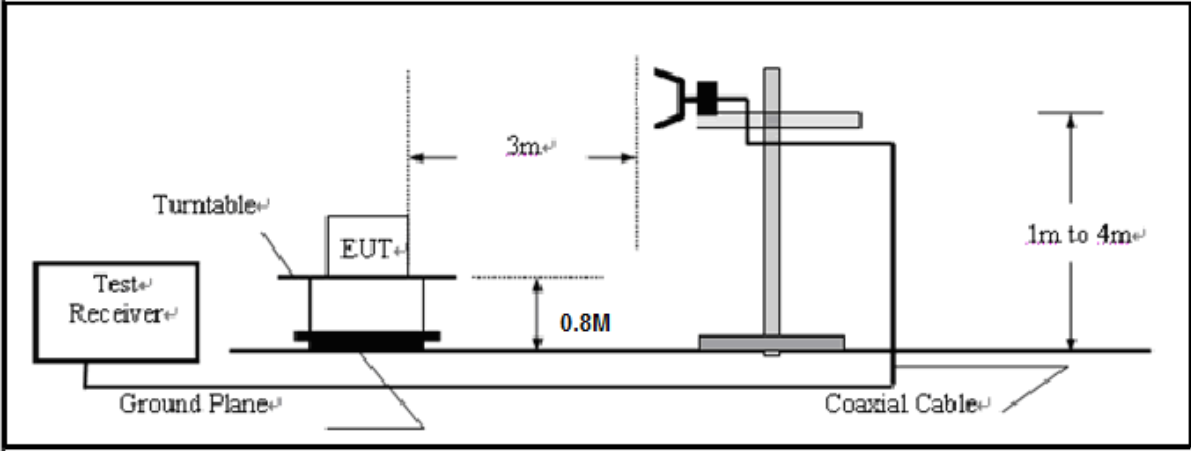

7.4. TEST RESULT

RADIATED EMISSION BELOW 30MHZ

No emission found between lowest internal used/generated frequencies to 30MHz.

RADIATED EMISSION 30MHz- 1GHZ

EUT	2.4GHz Wireless Mouse	Model Name.	OM4750W
Temperature	20	Relative Humidity	48%
Pressure	1010 hPa	Test Voltage	DC3V
Test Mode	Mode 1	Polarization :	Horizontal

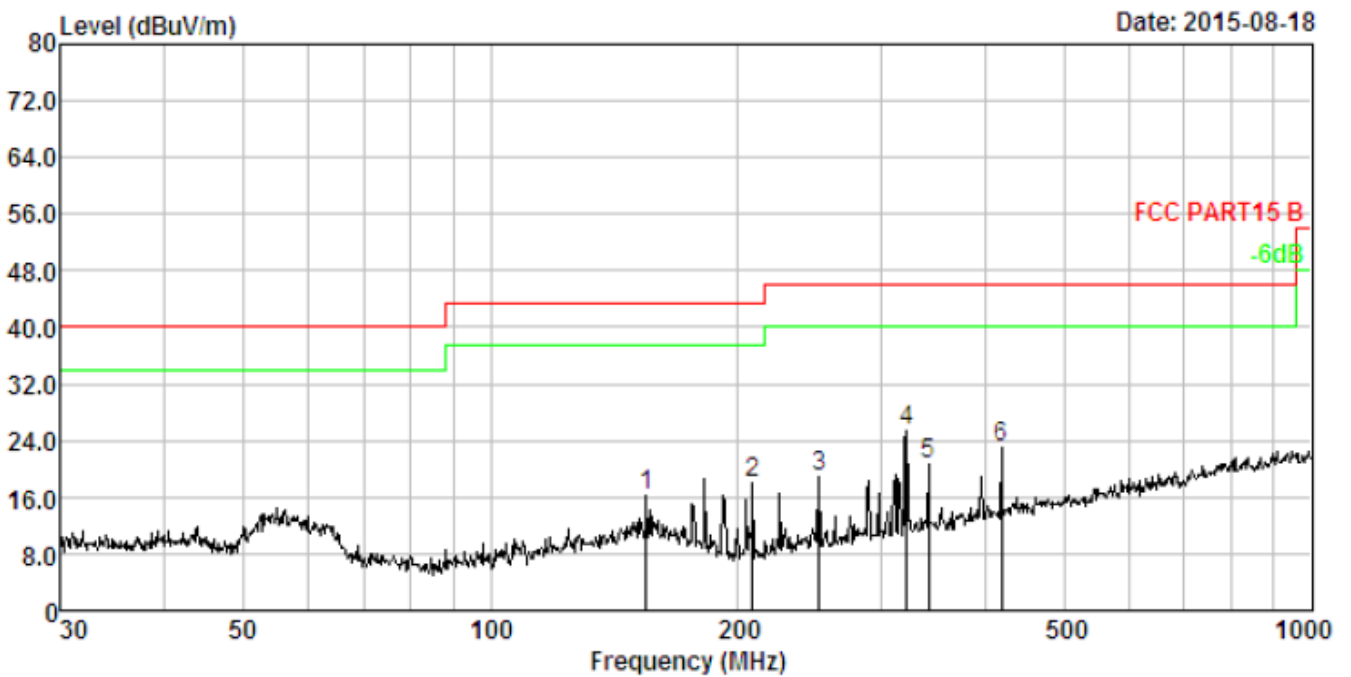

No.	Freq MHz	Cable Loss dB	ANT Factor dB/m	Receiver Reading dBuV	Preamp Factor dB	Emission Level dBuV/m	Limit dBuV/m	Over Limit dB	Remark
1.	154.821	2.54	13.89	30.44	30.54	16.33	43.50	-27.17	Peak
2.	208.580	2.81	10.55	35.31	30.64	18.03	43.50	-25.47	Peak
3.	251.180	2.98	11.95	34.71	30.71	18.93	46.00	-27.07	Peak
4.	321.061	3.20	13.67	39.27	30.79	25.35	46.00	-20.65	Peak
5.	341.979	3.26	14.12	34.22	30.82	20.78	46.00	-25.22	Peak
6.	419.108	3.44	15.68	34.86	30.89	23.09	46.00	-22.91	Peak

RESULT: PASS

EUT	2.4GHz Wireless Mouse	Model Name.	OM4750W
Temperature	20	Relative Humidity	48%
Pressure	1010 hPa	Test Voltage	DC3V
Test Mode	Mode 1	Polarization :	Vertical

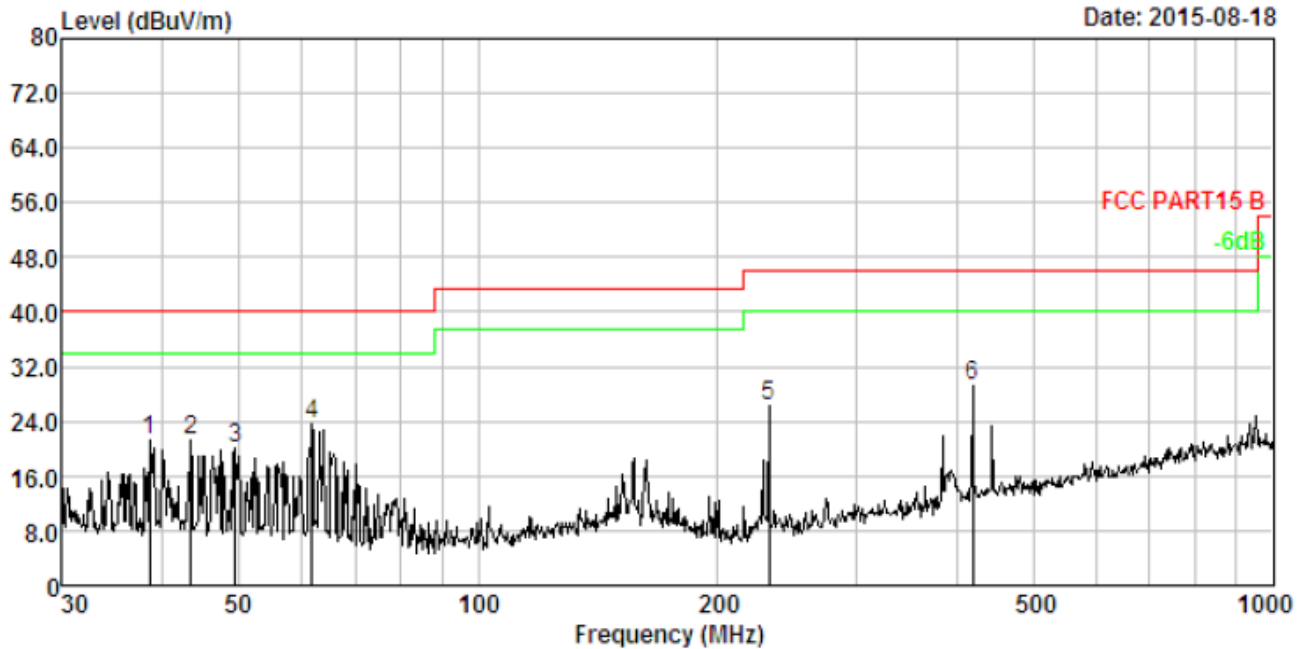

No.	Freq MHz	Cable Loss dB	ANT Factor dB/m	Receiver Reading dBuV	Preamp Factor dB	Emission Level dBuV/m	Limit dBuV/m	Over Limit dB	Remark
1.	38.616	1.28	13.60	36.52	30.06	21.34	40.00	-18.66	Peak
2.	43.506	1.39	13.38	36.64	30.10	21.31	40.00	-18.69	Peak
3.	49.533	1.51	12.36	36.26	30.14	19.99	40.00	-20.01	Peak
4.	61.778	1.71	12.05	40.16	30.22	23.70	40.00	-16.30	Peak
5.	232.532	2.91	11.36	42.74	30.68	26.33	46.00	-19.67	Peak
6.	419.108	3.44	15.68	40.91	30.89	29.14	46.00	-16.86	Peak

RESULT: PASS

Note:

Factor=Antenna Factor + Cable loss, Margin=Result-Limit.

The "Factor" value can be calculated automatically by software of measurement system.

The mode 1 is the worst case, and only the data of the worst case recorded in this test report.

RADIATED EMISSION ABOVE 1GHZ

EUT	2.4GHz Wireless Mouse	Model Name.	OM4750W
Temperature	20	Relative Humidity	48%
Pressure	1010 hPa	Test Voltage	DC3V
Test Mode	Mode 1	Polarization :	Horizontal

Frequency (MHz)	Meter Reading (dBµV)	Factor (dB)	Emission Level (dBµV/m)	Limits (dBµV/m)	Margin (dB)	Value Type
2409.013	96.73	-9.37	87.36	114	-26.64	peak
2409.013	86.34	-9.37	76.97	94	-17.03	AVG
4818.026	42.56	3.74	46.3	74	-27.7	peak
4818.026	30.34	3.74	34.08	54	-19.92	AVG
7227.039	39.57	8.14	47.71	74	-26.29	peak
7227.039	28.29	8.14	36.43	54	-17.57	AVG

Remark:
Factor = Antenna Factor + Cable Loss – Pre-amplifier.

EUT	2.4GHz Wireless Mouse	Model Name.	OM4750W
Temperature	20	Relative Humidity	48%
Pressure	1010 hPa	Test Voltage	DC3V
Test Mode	Mode 1	Polarization :	Vertical

Frequency (MHz)	Meter Reading (dBµV)	Factor (dB)	Emission Level (dBµV/m)	Limits (dBµV/m)	Margin (dB)	Value Type
2409.013	97.58	-9.37	88.21	114	-25.79	peak
2409.013	88.06	-9.37	78.69	94	-15.31	AVG
4818.026	43.38	3.74	47.12	74	-26.88	peak
4818.026	31.51	3.74	35.25	54	-18.75	AVG
7227.039	40.34	8.14	48.48	74	-25.52	peak
7227.039	29.47	8.14	37.61	54	-16.39	AVG

Remark:
Factor = Antenna Factor + Cable Loss – Pre-amplifier.

EUT	2.4GHz Wireless Mouse	Model Name.	OM4750W
Temperature	20	Relative Humidity	48%
Pressure	1010 hPa	Test Voltage	DC3V
Test Mode	Mode 2	Polarization :	Horizontal

Frequency (MHz)	Meter Reading (dB μ V)	Factor (dB)	Emission Level (dB μ V/m)	Limits (dB μ V/m)	Margin (dB)	Value Type
2440.016	98.67	-9.63	89.04	114	-24.96	peak
2440.016	88.37	-9.63	78.74	94	-15.26	AVG
4880.032	41.27	3.76	45.03	74	-28.97	peak
4880.032	30.49	3.76	34.25	54	-19.75	AVG
7320.048	40.37	8.17	48.54	74	-25.46	peak
7320.048	30.26	8.17	38.43	54	-15.57	AVG

Remark:
Factor = Antenna Factor + Cable Loss – Pre-amplifier.

EUT	2.4GHz Wireless Mouse	Model Name.	OM4750W
Temperature	20	Relative Humidity	48%
Pressure	1010 hPa	Test Voltage	DC3V
Test Mode	Mode 2	Polarization :	Vertical

Frequency (MHz)	Meter Reading (dB μ V)	Factor (dB)	Emission Level (dB μ V/m)	Limits (dB μ V/m)	Margin (dB)	Value Type
2440.016	99.67	-9.63	90.04	114	-23.96	peak
2440.016	90.53	-9.63	80.9	94	-13.1	AVG
4880.032	42.24	3.76	46	74	-28	peak
4880.032	31.56	3.76	35.32	54	-18.68	AVG
7320.048	40.64	8.17	48.81	74	-25.19	peak
7320.048	30.29	8.17	38.46	54	-15.54	AVG

Remark:
Factor = Antenna Factor + Cable Loss – Pre-amplifier.

EUT	2.4GHz Wireless Mouse	Model Name.	OM4750W
Temperature	20	Relative Humidity	48%
Pressure	1010 hPa	Test Voltage	DC3V
Test Mode	Mode 3	Polarization :	Horizontal

Frequency (MHz)	Meter Reading (dB μ V)	Factor (dB)	Emission Level (dB μ V/m)	Limits (dB μ V/m)	Margin (dB)	Value Type
2476.021	97.62	-9.61	88.01	114	-25.99	peak
2476.021	86.94	-9.61	77.33	94	-16.67	AVG
4952.042	42.67	3.83	46.5	74	-27.5	peak
4952.042	32.27	3.83	36.1	54	-17.9	AVG
7428.063	39.36	8.21	47.57	74	-26.43	peak
7428.063	31.53	8.21	39.74	54	-14.26	AVG

Remark:

Factor = Antenna Factor + Cable Loss – Pre-amplifier.

EUT	2.4GHz Wireless Mouse	Model Name.	OM4750W
Temperature	20	Relative Humidity	48%
Pressure	1010 hPa	Test Voltage	DC3V
Test Mode	Mode 3	Polarization :	Vertical

Frequency (MHz)	Meter Reading (dB μ V)	Factor (dB)	Emission Level (dB μ V/m)	Limits (dB μ V/m)	Margin (dB)	Value Type
2476.021	98.19	-9.61	88.58	114	-25.42	peak
2476.021	87.98	-9.61	78.37	94	-15.63	AVG
4952.042	42.57	3.83	46.4	74	-27.6	peak
4952.042	31.39	3.83	35.22	54	-18.78	AVG
7428.063	40.27	8.21	48.48	74	-25.52	peak
7428.063	32.16	8.21	40.37	54	-13.63	AVG

Remark:

Factor = Antenna Factor + Cable Loss – Pre-amplifier.

Note: Other emission from 8G to 25 GHz are considered as ambient noise. No recording in the test report.

Factor=Antenna Factor + Cable loss - Amplifier gain, Margin=Measurement-Limit.

The “Factor” value can be calculated automatically by software of measurement system.

The spurious emission of mode 4 are considered as ambient noise. No recording in the test report.

8. BAND EDGE EMISSION

8.1. MEASUREMENT PROCEDURE

1The EUT operates at hopping-off test mode. The lowest or highest channels are tested to verify the largest transmission and spurious emissions power at the continuous transmission mode.

2Max hold the trace of the setp 1,and the EUT operates at hopping-on test mode to verify the largest spurious emissions power.

3Set the spectrum analyzer in the following setting in order to capture the lower and upper band-edges of the emission: (a) PEAK: RBW=VBW=1MHz / Sweep=AUTO

(b) AVERAGE: RBW=1MHz ; VBW=1/on time(1KHz) / Sweep=AUTO

8.2 TEST SETUP

RADIATED EMISSION TEST SETUP

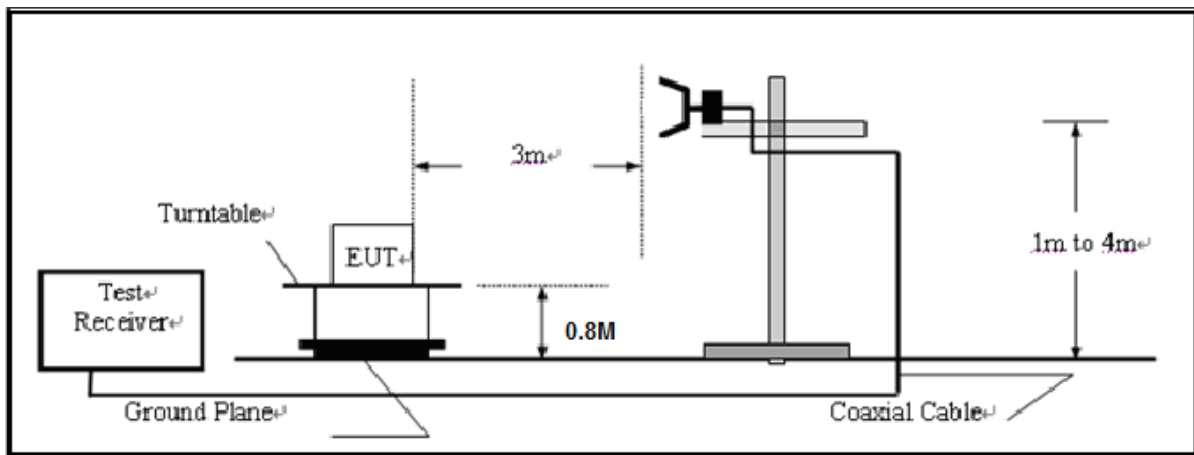

CONDUCTED TEST SETUP

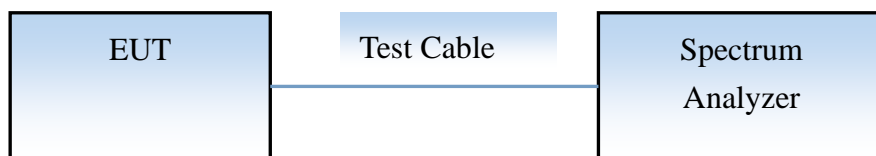

8.3 RADIATED TEST RESULT

EUT	2.4GHz Wireless Mouse	Model Name.	OM4750W
Temperature	20	Relative Humidity	48%
Pressure	1010 hPa	Test Voltage	DC3V
Test Mode	Mode 1	Polarization :	Horizontal

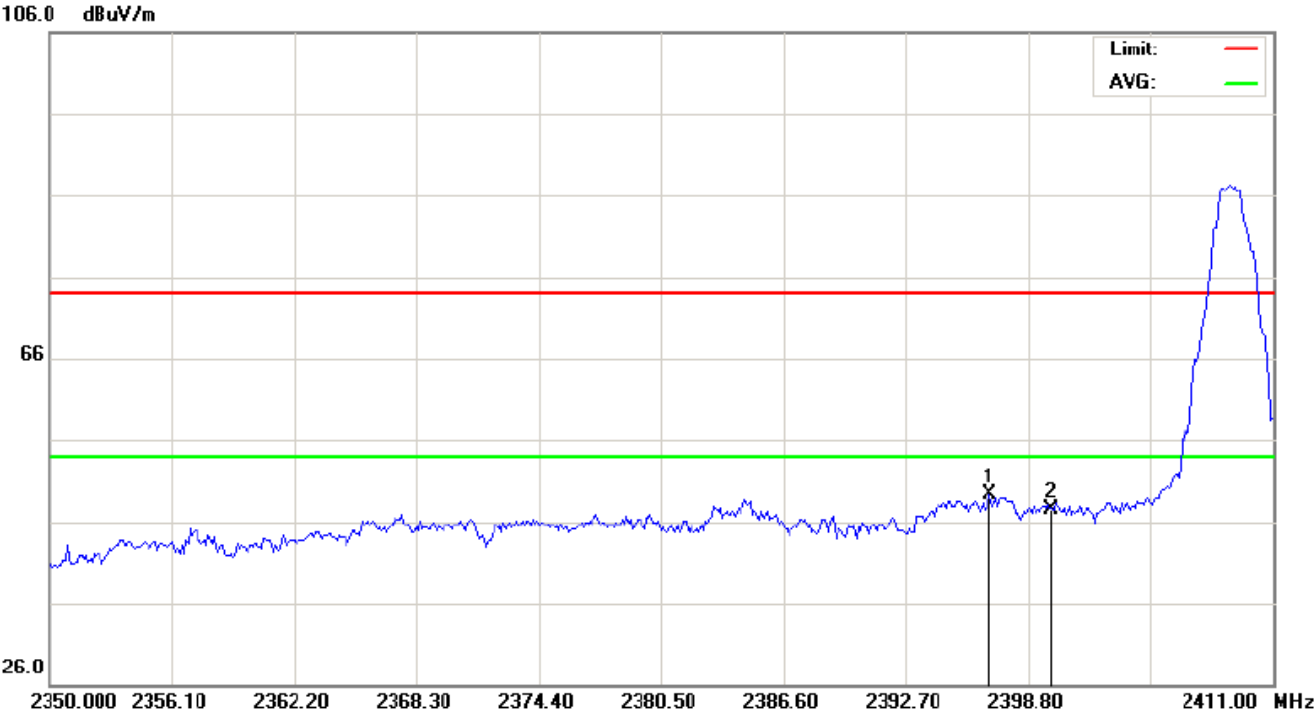

Frequency (MHz)	Meter Reading (dBμV)	Factor (dB)	Emission Level (dBμV/m)	Limits (dBμV/m)	Margin (dB)	Value Type
2396.868	62.48	-13.00	49.48	74	-24.52	peak
2400.000	60.76	-12.99	47.77	74	-26.23	peak

Remark:
Factor = Antenna Factor + Cable Loss – Pre-amplifier.

EUT	2.4GHz Wireless Mouse	Model Name.	OM4750W
Temperature	20	Relative Humidity	48%
Pressure	1010 hPa	Test Voltage	DC3V
Test Mode	Mode 1	Polarization :	Vertical

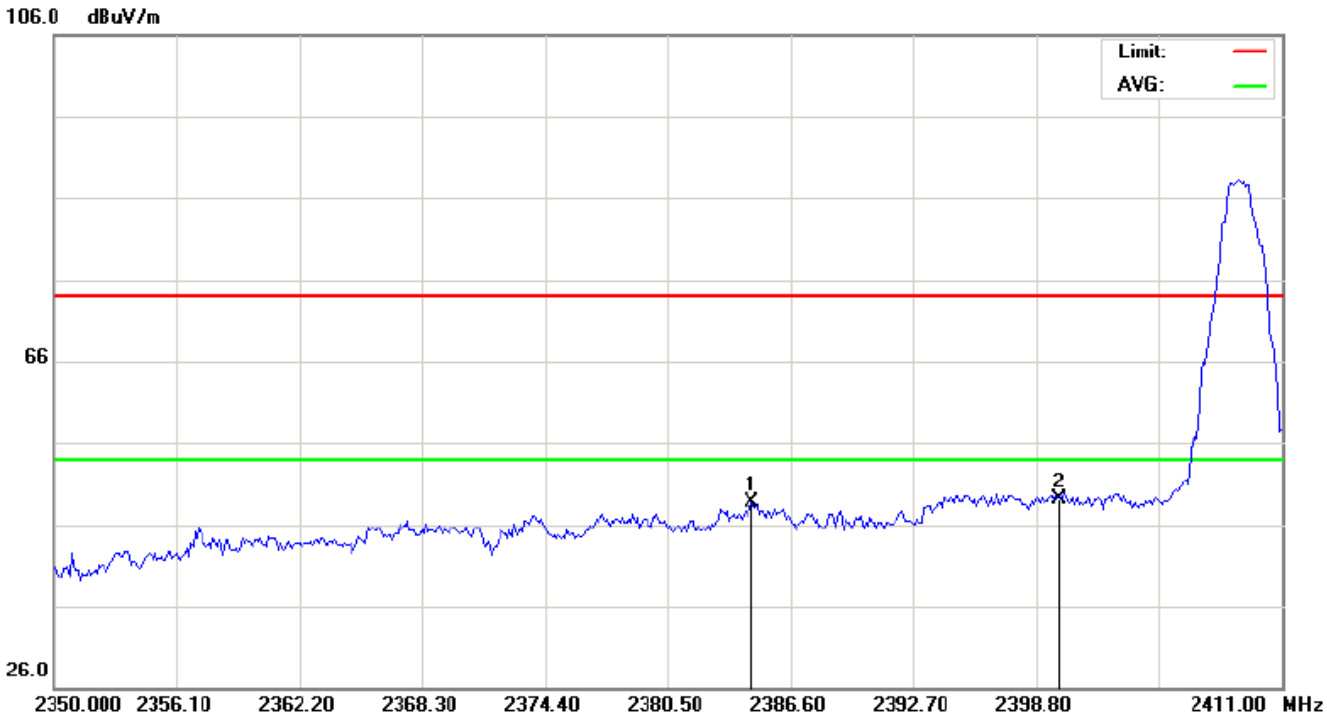

Frequency (MHz)	Meter Reading (dBμV)	Factor (dB)	Emission Level (dBμV/m)	Limits (dBμV/m)	Margin (dB)	Value Type
2385.437	61.26	-13.00	48.26	74	-25.74	peak
2400.000	62.04	-12.99	49.05	74	-24.95	peak
Remark:						
Factor = Antenna Factor + Cable Loss – Pre-amplifier.						

EUT	2.4GHz Wireless Mouse	Model Name.	OM4750W
Temperature	20	Relative Humidity	48%
Pressure	1010 hPa	Test Voltage	DC3V
Test Mode	Mode 3	Polarization :	Horizontal

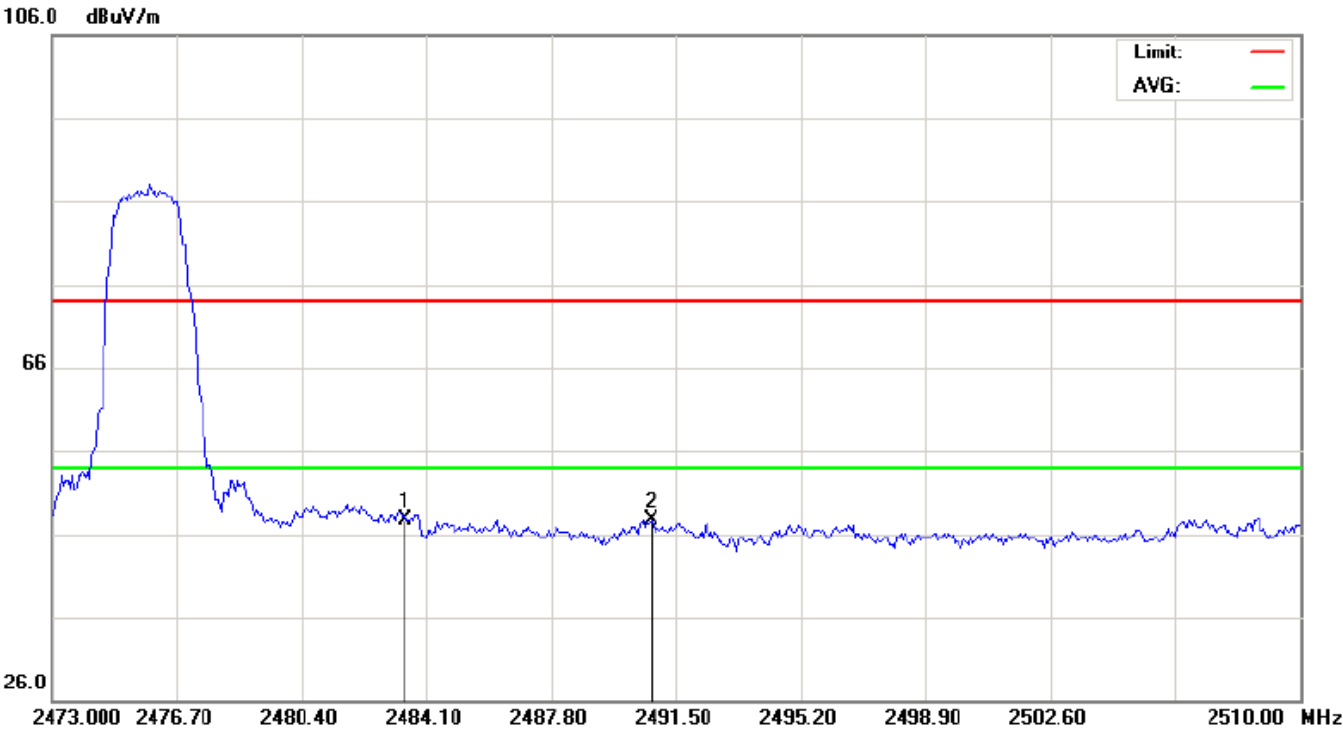

Frequency (MHz)	Meter Reading (dBµV)	Factor (dB)	Emission Level (dBµV/m)	Limits (dBµV/m)	Margin (dB)	Value Type
2483.500	60.59	-12.78	47.81	74	-26.19	peak
2484.600	60.64	-12.77	47.87	74	-26.13	peak

Remark:
Factor = Antenna Factor + Cable Loss – Pre-amplifier.

EUT	2.4GHz Wireless Mouse	Model Name.	OM4750W
Temperature	20	Relative Humidity	48%
Pressure	1010 hPa	Test Voltage	DC3V
Test Mode	Mode 3	Polarization :	Vertical

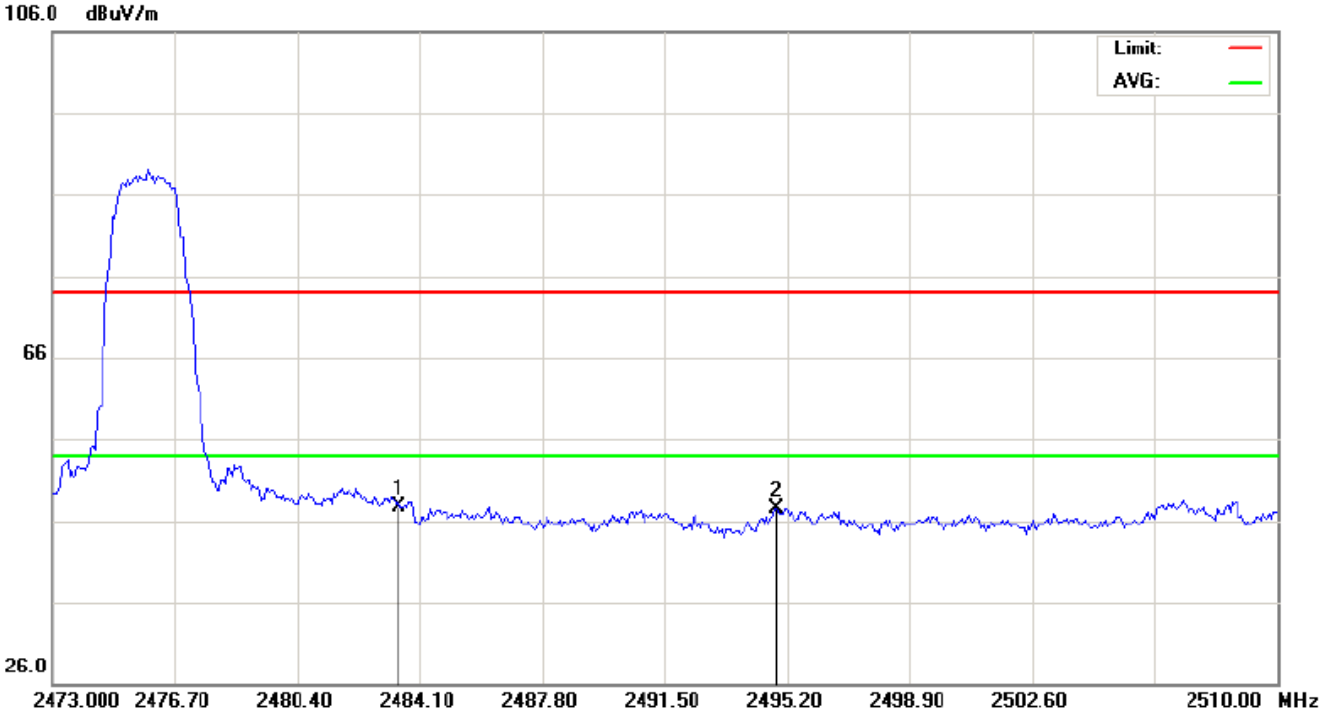

Frequency (MHz)	Meter Reading (dBμV)	Factor (dB)	Emission Level (dBμV/m)	Limits (dBμV/m)	Margin (dB)	Value Type
2483.500	60.97	-12.78	48.19	74	-25.81	peak
2483.600	60.89	-12.77	48.12	74	-25.88	peak
Remark:						
Factor = Antenna Factor + Cable Loss – Pre-amplifier.						

Note:
 Factor=Antenna Factor + Cable loss - Amplifier gain, Over=Measure-Limit.
 The “Factor” value can be calculated automatically by software of measurement system.
 The PK emission level are less than AV limit so the AV emission level are not recorded.

9. 20DB BANDWIDTH

9.1. MEASUREMENT PROCEDURE

1. Connect EUT RF output port to the Spectrum Analyzer through an RF attenuator
2. Set the EUT Work on the top, the middle and the bottom operation frequency individually.
3. Set SPA Centre Frequency = Operation Frequency, RBW= 100 KHz, VBW 3 RBW.
4. Set SPA Trace 1 Max hold, then View.

9.2. TEST SET-UP (BLOCK DIAGRAM OF CONFIGURATION)

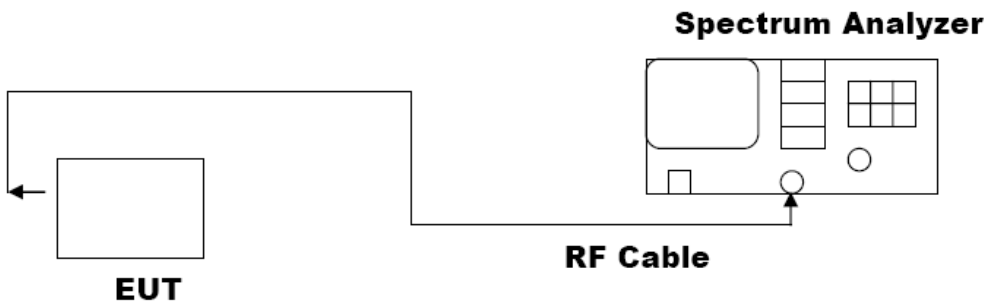

9.3. MEASUREMENT RESULTS

TEST ITEM	20DB BANDWIDTH
TEST MODE	Mode1;Mode2;Mode3

Test Data (MHz)		Criteria
Low Channel	2.683	PASS
Middle Channel	2.601	PASS
High Channel	2.518	PASS

TEST PLOT OF BANDWIDTH FOR LOW CHANNEL

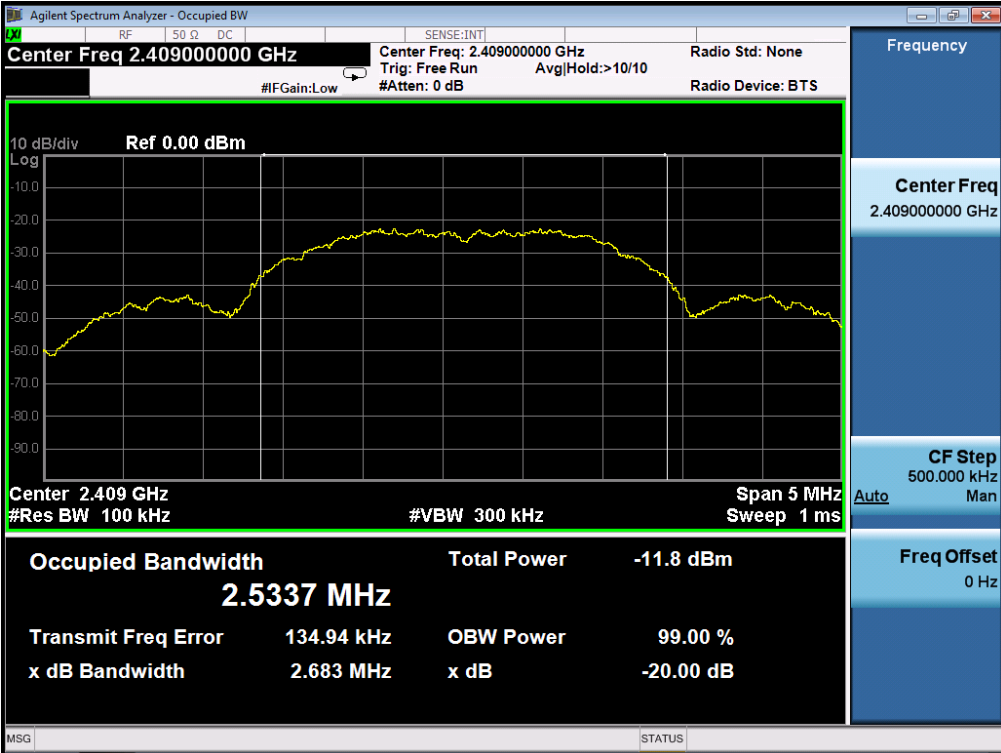

TEST PLOT OF BANDWIDTH FOR MIDDLE CHANNEL

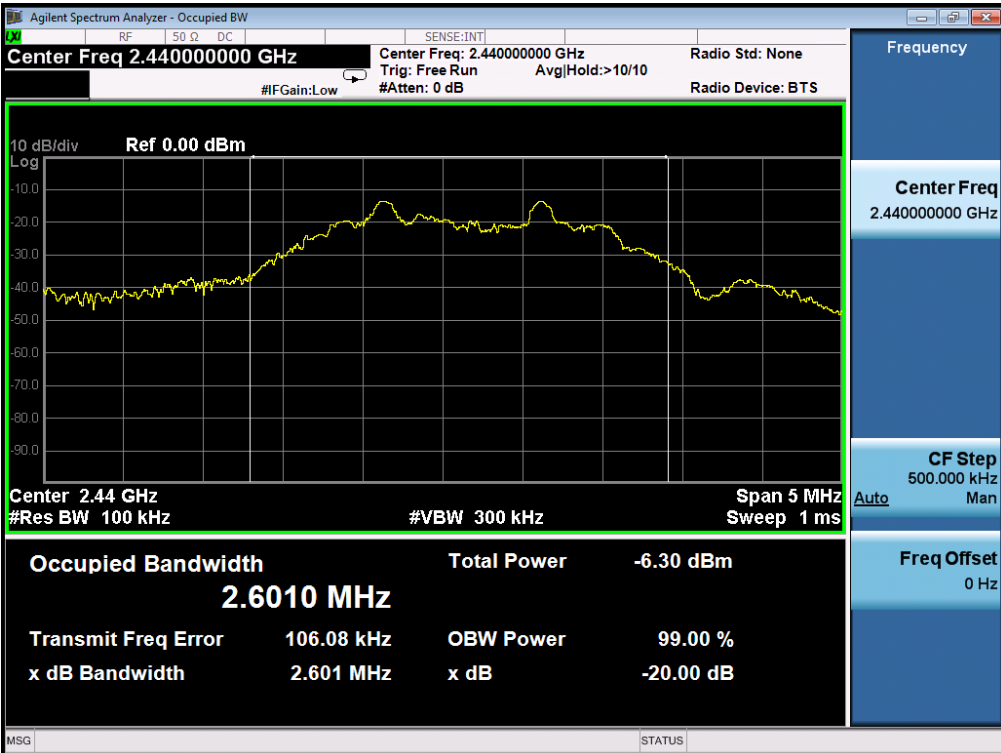

TEST PLOT OF BANDWIDTH FOR HIGH CHANNEL

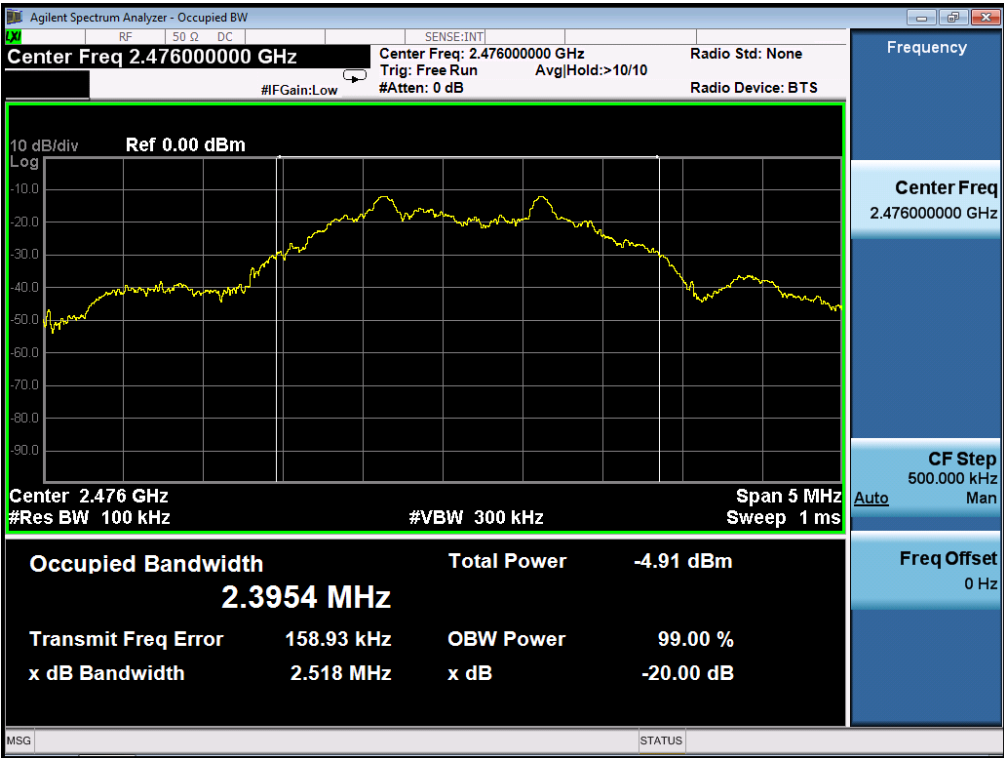

APPENDIX A: PHOTOGRAPHS OF TEST SETUP
RADIATED EMISSION TEST SETUP BELOW 1GHz

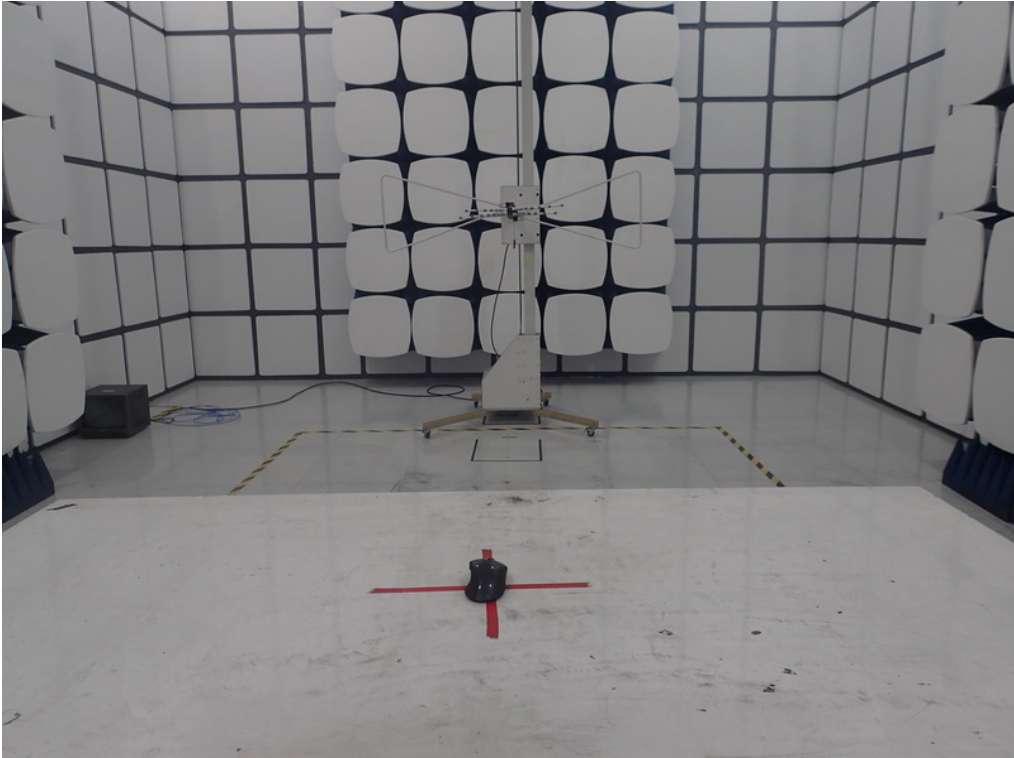

RADIATED EMISSION TEST SETUP ABOVE 1GHz

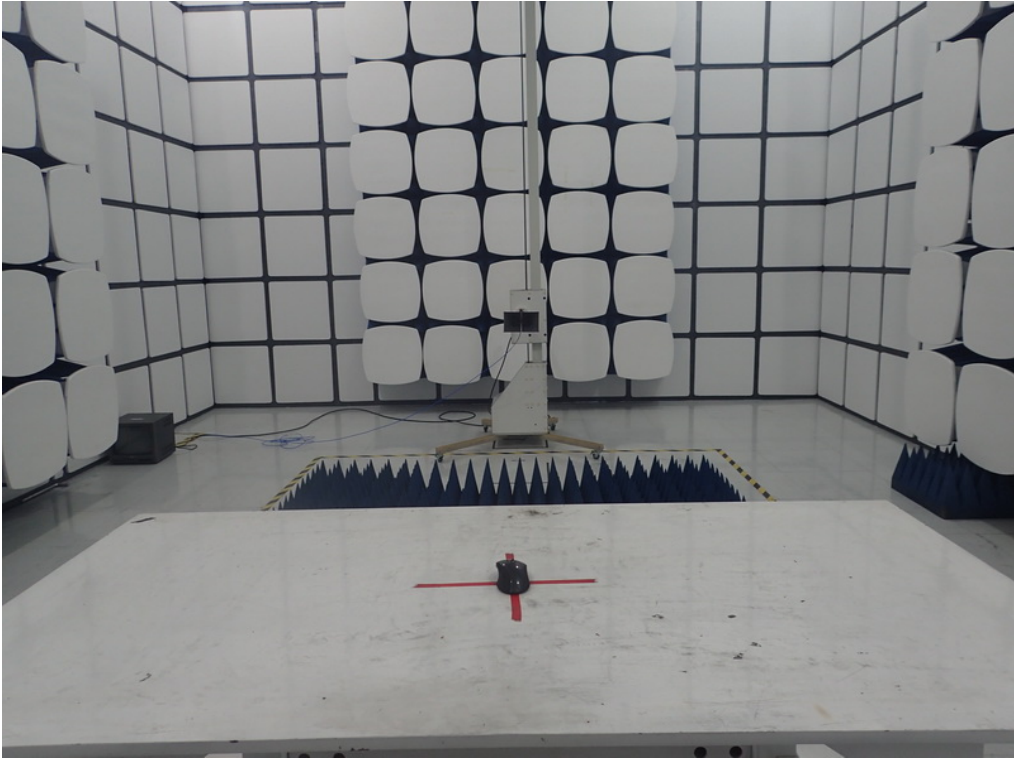

APPENDIX B: PHOTOGRAPHS OF EUT
TOP VIEW OF EUT



BOTTOM VIEW OF EUT



FRONT VIEW OF EUT



BACK VIEW OF EUT



LEFT VIEW OF EUT



RIGHT VIEW OF EUT



OPEN VIEW OF EUT-1



OPEN VIEW OF EUT-2

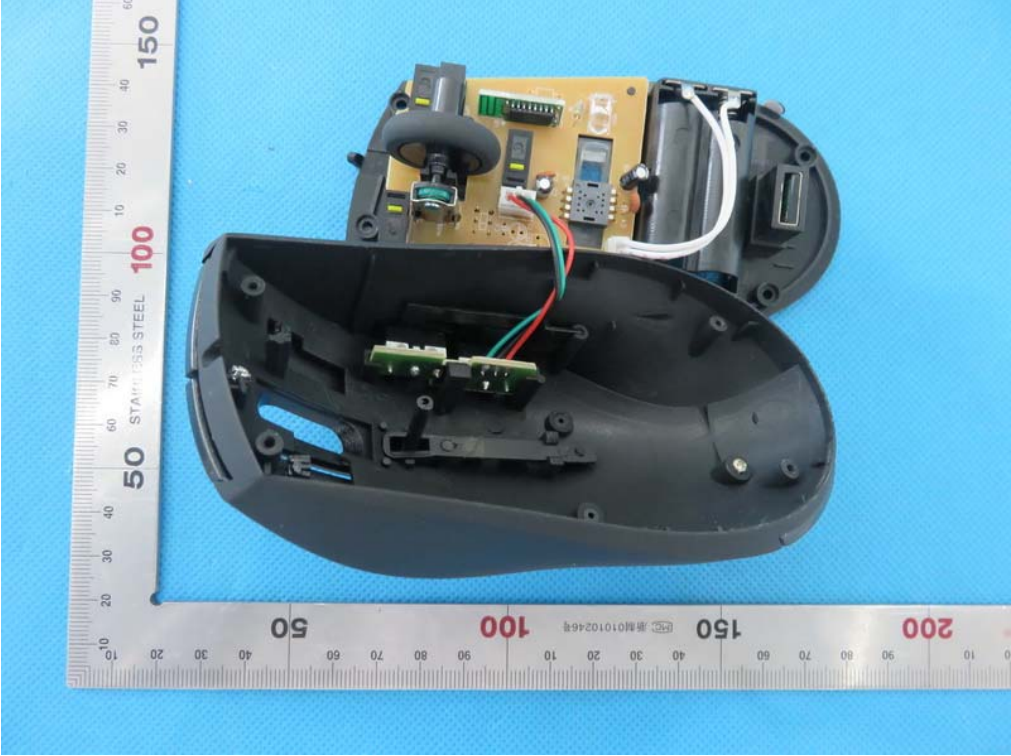

INTERNAL VIEW OF EUT-1

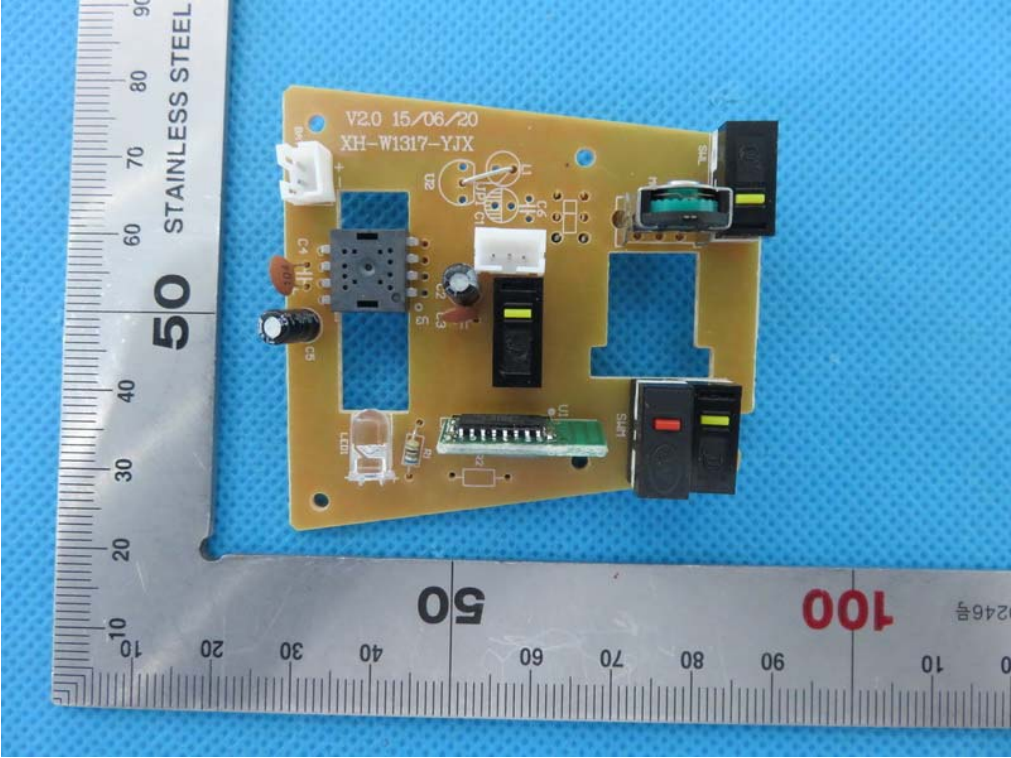

INTERNAL VIEW OF EUT-2

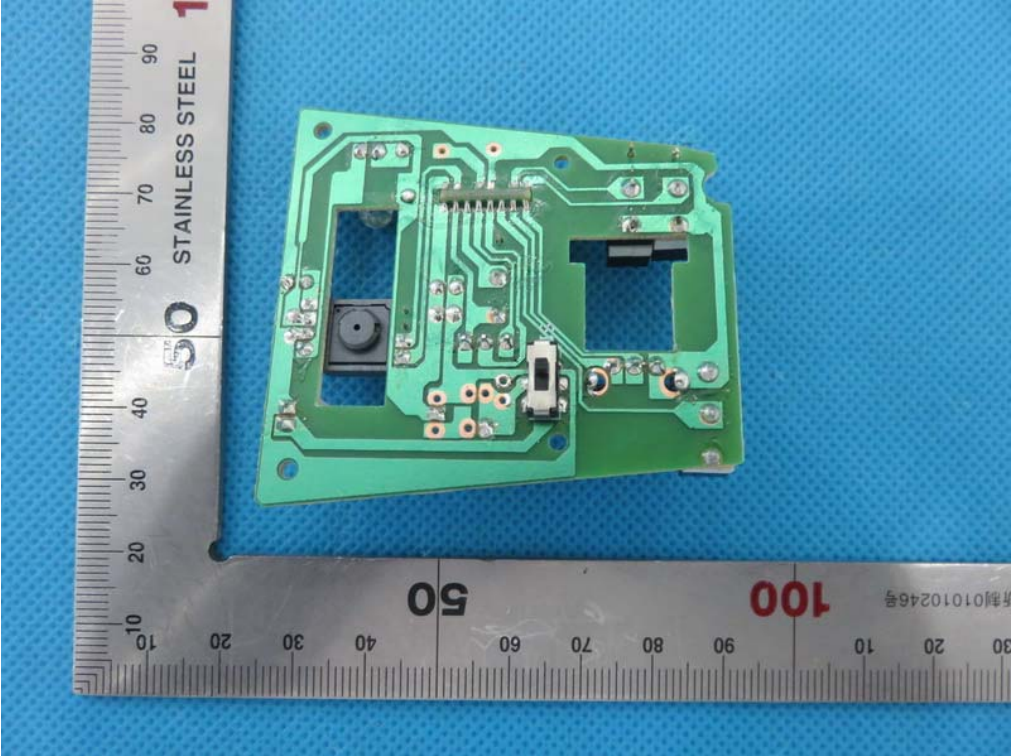

INTERNAL VIEW OF EUT-3

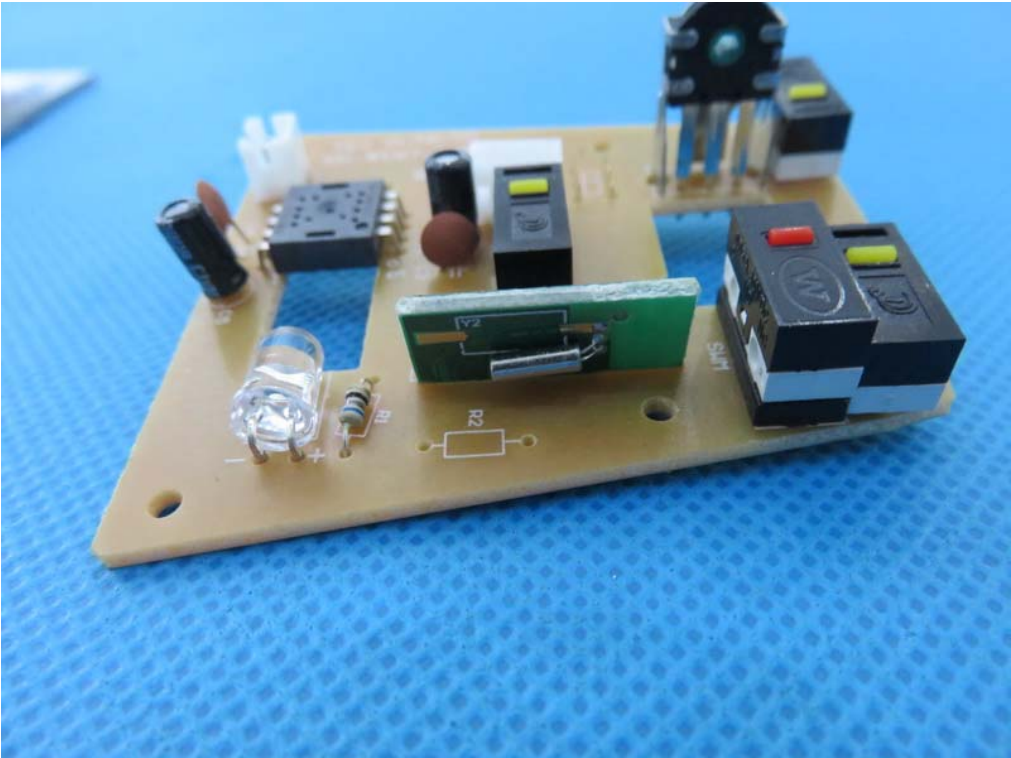

INTERNAL VIEW OF EUT-4

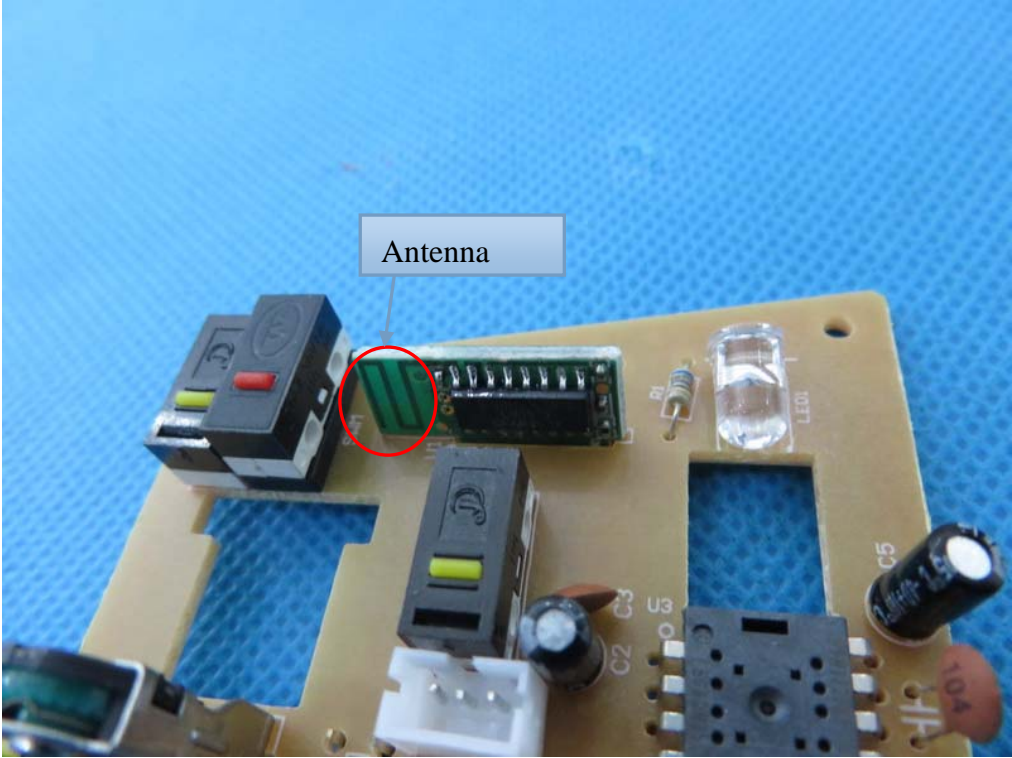

----END OF REPORT----