



FCC PART 15.407
 IC RSS-247, ISSUE 1, 2015
 TEST REPORT

For

TruePath Wireless LLC

2860 Zanker Road, Suite 210,

San Jose, CA 95134, USA

FCC ID: ZJ3-TPWLR58B1
IC: 9698A-TPWLR58B1

Report Type: Original Report	Product Type: Wireless Base Station
Prepared By: Simon Ma	<i>Simon Ma</i>
Report Number: R1502251-407 Rev A	
Report Date: 2015-09-29	
Reviewed By: Bo Li	<i>Bo Li</i>
Reviewed By: RF Lead	
Bay Area Compliance Laboratories Corp. 1274 Anvilwood Avenue, Sunnyvale, CA 94089, USA Tel: 1 (408) 732-9162 Fax: 1 (408) 732-9164	

Note: This test report is prepared for the customer shown above and for the device described herein. It may not be duplicated or used in part without prior written consent from Bay Area Compliance Laboratories Corp. This report **must not** be used by the customer to claim product certification, approval, or endorsement by A2LA*, NIST, or any agency of the Federal Government.

* This report may contain data that are not covered by the A2LA accreditation and are marked with an asterisk "*"...

TABLE OF CONTENTS

1	GENERAL DESCRIPTION.....	5
1.1	PRODUCT DESCRIPTION FOR EQUIPMENT UNDER TEST (EUT).....	5
1.2	MECHANICAL DESCRIPTION OF EUT.....	5
1.3	OBJECTIVE.....	5
1.4	RELATED SUBMITTAL(S)/GRANT(S).....	5
1.5	TEST METHODOLOGY.....	5
1.6	TEST FACILITY REGISTRATIONS.....	5
1.7	TEST FACILITY ACCREDITATIONS.....	6
1.8	MEASUREMENT UNCERTAINTIES.....	7
2	EUT TEST CONFIGURATION.....	8
2.1	JUSTIFICATION.....	8
2.2	EUT EXERCISE SOFTWARE.....	8
2.3	SPECIAL EQUIPMENT.....	8
2.4	EQUIPMENT MODIFICATIONS.....	8
2.5	LOCAL SUPPORT EQUIPMENT.....	8
2.6	EUT INTERNAL CONFIGURATION DETAILS.....	9
2.7	INTERFACE PORTS AND CABLES.....	9
2.8	POWER SUPPLY LIST AND DETAILS.....	9
3	SUMMARY OF TEST RESULTS.....	10
4	FCC §2.1091 & §15.407(F) IC RSS-102 - RF EXPOSURE.....	11
4.1	APPLICABLE STANDARD.....	11
4.2	MPE PREDICTION.....	12
4.3	MPE RESULTS.....	12
5	FCC §15.203 & IC RSS-GEN §8.3 – ANTENNA REQUIREMENTS.....	14
5.1	APPLICABLE STANDARD.....	14
5.2	ANTENNA DESCRIPTION.....	14
6	FCC §15.207 & IC RSS-GEN §8.8 - AC POWER LINE CONDUCTED EMISSIONS.....	15
6.1	APPLICABLE STANDARDS.....	15
6.2	TEST SETUP.....	15
6.3	TEST PROCEDURE.....	15
6.4	TEST SETUP BLOCK DIAGRAM.....	16
6.5	CORRECTED AMPLITUDE & MARGIN CALCULATION.....	16
6.6	TEST EQUIPMENT LIST AND DETAILS.....	17
6.7	TEST ENVIRONMENTAL CONDITIONS.....	17
6.8	SUMMARY OF TEST RESULTS.....	17
6.9	CONDUCTED EMISSIONS TEST PLOTS AND DATA.....	18
7	FCC §15.209, §15.407(B) & IC RSS-247 §6.2.4 (2) - SPURIOUS RADIATED EMISSIONS.....	20
8	FCC §15.407(A), §15.407(E) & IC RSS-GEN §6.6, RSS-247 §6.2.4 (1) – EMISSION BANDWIDTH.....	21
8.1	APPLICABLE STANDARDS.....	21
8.2	MEASUREMENT PROCEDURE.....	21
8.3	TEST EQUIPMENT LIST AND DETAILS.....	21
8.4	TEST ENVIRONMENTAL CONDITIONS.....	21
8.5	TEST RESULTS.....	22
9	FCC §407(A) & IC RSS-247 §6.2.4 (1) – MAXIMUM CONDUCTED OUTPUT POWER.....	46

9.1	APPLICABLE STANDARDS	46
9.2	MEASUREMENT PROCEDURE	46
9.3	TEST EQUIPMENT LIST AND DETAILS	46
9.4	TEST ENVIRONMENTAL CONDITIONS.....	47
9.5	TEST RESULTS	47
10	FCC §407(B) & IC RSS-247 §6.2.4 (2) – BAND EDGE	109
10.1	APPLICABLE STANDARDS	109
10.2	MEASUREMENT PROCEDURE	109
10.3	TEST EQUIPMENT LIST AND DETAILS	110
10.4	TEST ENVIRONMENTAL CONDITIONS.....	110
10.5	TEST RESULTS	110
11	FCC §15.407(A) & IC RSS-247 §6.2.4 (1) - POWER SPECTRAL DENSITY.....	120
11.1	APPLICABLE STANDARDS	120
11.2	MEASUREMENT PROCEDURE	120
11.3	TEST EQUIPMENT LIST AND DETAILS	120
11.4	TEST ENVIRONMENTAL CONDITIONS.....	121
11.5	TEST RESULTS	121
12	EXHIBIT A – FCC & IC EQUIPMENT LABELLING REQUIREMENTS.....	138
12.1	FCC ID LABEL REQUIREMENTS	138
12.2	IC LABEL REQUIREMENTS.....	138
12.3	FCC ID & IC LABEL CONTENTS AND LOCATION.....	139
13	EXHIBIT B - EUT SETUP PHOTOGRAPHS	140
13.1	AC LINE CONDUCTED EMISSION FRONT VIEW.....	140
13.2	AC LINE CONDUCTED EMISSION SIDE VIEW	140
14	EXHIBIT C – EUT PHOTOGRAPHS.....	141
14.1	EUT – FRONT VIEW	141
14.2	EUT – REAR VIEW	141
14.3	EUT – TOP AND SIDE VIEW.....	142
14.4	EUT – BOTTOM AND SIDE VIEW	142
14.5	CPU – TOP VIEW.....	143
14.6	CPU – BOTTOM VIEW	143
14.7	FPGA – TOP VIEW	144
14.8	JUMPER BOARD – BOTTOM VIEW	144
14.9	QUAD-RFE – COVER OFF VIEW.....	145
14.10	QUAD-RFE – COVER OFF DETAIL VIEW.....	145
14.11	RF-XCVR – TOP VIEW	146
14.12	RF-XCVR – BOTTOM VIEW W/ SHIELDING	146
14.13	RF-XCVR – BOTTOM VIEW W/O SHIELDING	147
14.14	PSU – TOP VIEW.....	147
14.15	PSU – BOTTOM VIEW	148
14.16	PSU – FRONT VIEW	148
14.17	PSU – REAR VIEW	149
14.18	PSU – LEFT SIDE VIEW	149
14.19	PSU – RIGHT SIDE VIEW.....	150
14.20	PSU – COVER OFF VIEW	150
14.21	PSU – PCB TOP VIEW.....	151
14.22	ANTENNA – FRONT VIEW	151
14.23	ANTENNA – REAR VIEW.....	152
14.24	ANTENNA – SIDE VIEW	152
14.25	ANTENNA – TOP VIEW	153
14.26	ANTENNA – BOTTOM VIEW.....	153

DOCUMENT REVISION HISTORY

Revision Number	Report Number	Description of Revision	Date of Revision
0	R1502251-407	Original Report	2015-09-08
1	R1502251-407 Rev A	Update High CH Data	2015-09-29

1 General Description

1.1 Product Description for Equipment under Test (EUT)

This test and measurement report has been compiled on behalf of *TruePath Wireless LLC*. And their product, *FCC ID: ZJ3-TPWLR58B1, IC: 9698A-TPWLR58B1*; model number: *TPWLR58B1*, which henceforth is referred to as the EUT (Equipment Under Test.) The EUT provides long range, central, wireless access point radio connection to TruePath client radios (CPEs).

1.2 Mechanical Description of EUT

The EUT measures approximately 790mm (L) x 500mm (W) x 260mm (H), weight is 28.35 kg.
The Antenna measures approximately 790mm (L) x 500mm (W) x 110mm (H), weight is 11.15 kg.

The data gathered are from a typical production sample provided by the manufacturer with serial number: 300000122, assigned by BACL.

1.3 Objective

This report is prepared on behalf of *TruePath Wireless LLC*. in accordance with FCC CFR47 §15.407 and IC RSS-247 Issue1. The objective is to determine compliance with FCC Part 15.407 and IC RSS-247 for Output Power, Antenna Requirements, AC Line Conducted Emissions, Bandwidth, and power spectral density, Band Edges Measurement, Spurious Emissions, Conducted and Radiated Spurious Emissions.

1.4 Related Submittal(s)/Grant(s)

N/A

1.5 Test Methodology

All measurements contained in this report were conducted in accordance with ANSI C63.4-2014, American National Standard for Methods of Measurement of Radio-Noise Emissions from Low-Voltage Electrical and Electronic Equipment in the range of 9 kHz to 40 GHz.

1.6 Test Facility Registrations

BACLs test facilities that are used to perform Radiated and Conducted Emissions tests are currently recognized by the Federal Communications Commission as Accredited with NIST Designation Number US1129.

BACL's test facilities that are used to perform Radiated and Conducted Emissions tests are currently registered with Industry Canada under Registration Numbers: 3062A-1, 3062A-2, and 3062A-3.

BACL is a Chinese Taipei Bureau of Standards Metrology and Inspection (BSMI) validated Conformity Assessment Body (CAB), under Appendix B, Phase I Procedures of the APEC Mutual Recognition Arrangement (MRA). BACL's BSMI Lab Code Number is: SL2-IN-E-1002R

BACL's test facilities that are used to perform AC Line Conducted Emissions, Telecommunications Line Conducted Emissions, Radiated Emissions from 30 MHz to 1 GHz, and Radiated Emissions from 1 GHz to 6 GHz are currently recognized as Accredited in accordance with the Voluntary Control Council for Interference [VCCI] Article 15 procedures under Registration Number A-0027.

1.7 Test Facility Accreditations

Bay Area Compliance Laboratories Corp. (BACL) is:

A- An independent, 3rd-Party, Commercial Test Laboratory accredited to ISO/IEC 17025:2005 by A2LA (Test Laboratory Accreditation Certificate Number 3279.02), in the fields of: Electromagnetic Compatibility and Telecommunications. Unless noted by an Asterisk (*) in the Compliance Matrix (See Section 3 of this Test Report), BACL's ISO/IEC 17025:2005 Scope of Accreditation includes all of the Test Method Standards and/or the Product Family Standards detailed in this Test Report..

BACL's ISO/IEC 17025:2005 Scope of Accreditation includes a comprehensive suite of EMC Emissions, EMC Immunity, Radio, RF Exposure, Safety and wireline Telecommunications test methods applicable to a wide range of product categories. These product categories include Central Office Telecommunications Equipment [including NEBS - Network Equipment Building Systems], Unlicensed and Licensed Wireless and RF devices, Information Technology Equipment (ITE); Telecommunications Terminal Equipment (TTE); Medical Electrical Equipment; Industrial, Scientific and Medical Test Equipment; Professional Audio and Video Equipment; Industrial and Scientific Instruments and Laboratory Apparatus; Cable Distribution Systems, and Energy Efficient Lighting.

B- A Product Certification Body accredited to ISO/IEC 17065:2012 by A2LA (Product Certification Body

- For the USA (Federal Communications Commission):

- 1- All Unlicensed radio frequency devices within FCC Scopes A1, A2, A3, and A4;
- 2- All Licensed radio frequency devices within FCC Scopes B1, B2, B3, and B4;
- 3- All Telephone Terminal Equipment within FCC Scope C.

- For the Canada (Industry Canada):

- 1- All Scope 1-Licence-Exempt Radio Frequency Devices;
- 2- All Scope 2-Licensed Personal Mobile Radio Services;
- 3- All Scope 3-Licensed General Mobile & Fixed Radio Services;
- 4- All Scope 4-Licensed Maritime & Aviation Radio Services;
- 5- All Scope 5-Licensed Fixed Microwave Radio Services
- 6- All Broadcasting Technical Standards (BETS) in the Category I Equipment Standards List.

For Singapore (Info-Communications Development Authority (IDA)):

- 1 All Line Terminal Equipment: All Technical Specifications for Line Terminal Equipment – Table 1 of IDA MRA Recognition Scheme: 2011, Annex 2
2. All Radio-Communication Equipment: All Technical Specifications for Radio-Communication Equipment – Table 2 of IDA MRA Recognition Scheme: 2011, Annex 2

- For the Hong Kong Special Administrative Region:

- 1 All Radio Equipment, per KHCA 10XX-series Specifications;
- 2 All GMDSS Marine Radio Equipment, per HKCA 12XX-series Specifications;
- 3 All Fixed Network Equipment, per HKCA 20XX-series Specifications.

- For Japan:

- 1 MIC Telecommunication Business Law (Terminal Equipment):
 - All Scope A1 - Terminal Equipment for the Purpose of Calls;
 - All Scope A2 - Other Terminal Equipment
- 2 Radio Law (Radio Equipment):
 - All Scope B1 - Specified Radio Equipment specified in Article 38-2-2, paragraph 1, item 1 of the Radio Law
 - All Scope B2 - Specified Radio Equipment specified in Article 38-2-2, paragraph 1, item 2 of the Radio Law
 - All Scope B3 - Specified Radio Equipment specified in Article 38-2-2, paragraph 1, item 3 of the Radio Law

1.8 Measurement Uncertainties

All measurements involve uncertainties. In the case of EMC Emissions tests, the influence quantities (factors) that make a significant contribution to the measurement uncertainties are detailed in the latest version of CISPR 16-4-2 “Specification for radio disturbance and immunity measuring apparatus and methods – Part 4-2: Uncertainties, statistics and limit modelling – Measurement instrumentation uncertainty” (i.e., CISPR 16-4-2:2011-06 + C1:2013-04 +A1:2014-02).

Based on the uncertainty models given in the latest version of CISPR16-4-2, and, based on the calibration uncertainties of the specific instruments and facilities used at BACL to perform the measurements documented in this Test Report, the following estimates have been made of BACL’s Measurement Uncertainties for the measurements documented in this Test Report.

Type of Measurement	Typical ULAB Value (for a k=2 Coverage Factor, equivalent to ~ 95% level of confidence) [Note: Calculated Values]	Typical ULAB Value (for a k=2 Coverage Factor, equivalent to ~ 95% level of confidence) [Note: all ULAB Calculated values have been rounded to the one significant figure to the right of the decimal]
Occupied Channel Bandwidth	± 1.052%	± 1.1 %
RF Output Power, Conducted	± 1.392 dB	± 1.4 dB
Power Spectral Density, Conducted	± 2.476 dB	± 2.5 dB
Unwanted Emissions, Conducted	± 2.465 dB	± 2.5 dB
All emissions, Radiated	±5.85 dB	±5.9 dB
Temperature	± 0.68 °C	± 0.7 °C
Supply Voltages	± 1.5%	± 1.5 %
Time	± 2.42%	± 2.4 %

2 EUT Test Configuration

2.1 Justification

The EUT was configured for testing according to ANSI C63.10-2013 and KDB-789033 D02 General UNII Test Procedures New Rules v01.

The EUT is designed to be capable of carrying 3 set antennas: 1 internal set includes 4 antenna elements and 2 external sets with 8 N-Type antenna ports. Transmitting antenna is controlled by internal switch so that only one antenna set works at a time.

The EUT was tested in the following configurations declared by TruePath Wireless LLC.,

Case 1: EUT 4 antenna chains are correlated to each other and transmit at the same time, 2 chains are in one polarization and 2 are in another polarization.

Case 2: EUT 4 antenna chains are fully un-correlated. Chain 1 and chain 3 transmit at one 20 MHz channel; chain 2 and chain 4 transmit at another 20 MHz channel. This configuration enables the EUT to transmit 40 MHz channel.

Case 3: EUT 4 antenna chains are fully un-correlated. Each chain cannot transmit at the same time.

The worst-case data rates are determined to be as follows for each mode based upon investigation by measuring the average power, peak power and PPSD across all data rates bandwidths, and modulations.

2.2 EUT Exercise Software

The test software sc3000_tx_ofdm_wb_1.4.0 was provided by TruePath Wireless LLC., which has been verified by Todd Moy.

2.3 Special Equipment

N/A

2.4 Equipment Modifications

No modifications were made to the EUT.

2.5 Local Support Equipment

Manufacturer	Description	Model No.	Serial No.
DELL	Laptop	Latitude E6530	-
Mikrotik	10-port Router	RB2011-iLN	-

2.6 EUT Internal Configuration Details

Manufacturer	Description	Model (P/N)	S/N
TruePath	RF Switch	100-00082-001	010
TruePath	Quad RFE	100-00088-001	148736400982
TruePath	DC/DC Power Supply	508-00098-001	143109400172
TruePath	RF XCVR	S14-1382	00008 (N486)
TruePath	CPU	S14-1381	00099
TruePath	FPGA	S14-1380	F1908

2.7 Interface Ports and Cables

Cable Description	Length (m)	To	From
Shielded E-net Cable	3	External Router Port	EUT RJ-45 Port
+48 VDC Power Cable	3	AC/DC PSU	EUT

2.8 Power Supply List and Details

Manufacturer	Description	Model	Serial Number
TruePath Wireless	AC/DC PSU	TPW-PS-002US (Z432U)	ZFHN2339

3 Summary of Test Results

FCC & IC Rules	Description of Test	Result
FCC §15.407(f), §2.1091 IC RSS-102	RF Exposure	Compliant
FCC §15.203 IC RSS-Gen §8.3	Antenna Requirement	Compliant
FCC §15.207 (a) IC RSS-Gen §8.8	AC Power Line Conducted Emissions	Compliant
FCC §15.209, §15.407(b) IC RSS-247 §6.2.4	Spurious Radiated Emissions	Note*
FCC §15.407(a) IC RSS-Gen §6.6 IC RSS-247 §6.2.4	Emission Bandwidth	Compliant
FCC §15.407(a) IC RSS-247 §6.2.4	Peak Output Power Measurement	Compliant
FCC §15.407(a)(3) IC RSS-247 §6.2.4	Power Spectral Density	Compliant
FCC §15.407(b) IC RSS-247 §6.2.4	Band Edge	Compliant

Note: Please refer to report number: 15U21301-E1 released by UL Verification Services INC. on June 23, 2015.

4 FCC §2.1091 & §15.407(f) IC RSS-102 - RF Exposure

4.1 Applicable Standard

According to FCC §15.407(f) and §1.1307(b)(1), systems operating under the provisions of this section shall be operated in a manner that ensures that the public is not exposed to radio frequency energy level in excess of the Commission's guidelines.

Limits for General Population/Uncontrolled Exposure

Frequency Range (MHz)	Electric Field Strength (V/m)	Magnetic Field Strength (A/m)	Power Density (mW/cm ²)	Averaging Time (minutes)
Limits for General Population/Uncontrolled Exposure				
0.3-1.34	614	1.63	* (100)	30
1.34-30	824/f	2.19/f	* (180/f ²)	30
30-300	27.5	0.073	0.2	30
300-1500	/	/	f/1500	30
1500-100,000	/	/	1.0	30

f = frequency in MHz

* = Plane-wave equivalent power density

Before equipment certification is granted, the procedure of IC RSS-102 must be followed concerning the exposure of humans to RF field

According to IC RSS-102 Issue 5 section 4, RF limits used for general public will be applied to the EUT.

Frequency Range (MHz)	Electric Field (V/m rms)	Magnetic Field (A/m rms)	Power Density (W/m ²)	Reference Period (minutes)
0.003-10 ²¹	83	90	-	Instantaneous*
0.1-10	-	0.73/ f	-	6**
1.1-10	87/ f ^{0.5}	-	-	6**
10-20	27.46	0.0728	2	6
20-48	58.07/ f ^{0.25}	0.1540/ f ^{0.25}	8.944/ f ^{0.5}	6
48-300	22.06	0.05852	1.291	6
300-6000	3.142 f ^{0.3417}	0.008335 f ^{0.3417}	0.02619 f ^{0.6834}	6
6000-15000	61.4	0.163	10	6
15000-150000	61.4	0.163	10	616000/ f ^{1.2}
150000-300000	0.158 f ^{0.5}	4.21 x 10 ⁻⁴ f ^{0.5}	6.67 x 10 ⁻⁵ f	616000/ f ^{1.2}
<p>Note: f is frequency in MHz. *Based on nerve stimulation (NS). ** Based on specific absorption rate (SAR).</p>				

4.2 MPE Prediction

Predication of MPE limit at a given distance, Equation from OET Bulletin 65, Edition 97-01

$$S = PG/4\pi R^2$$

Where: S = power density

P = power input to antenna

G = power gain of the antenna in the direction of interest relative to an isotropic radiator

R = distance to the center of radiation of the antenna

4.3 MPE Results

Case 1

<u>Maximum peak output power at antenna input terminal (dBm):</u>	<u>17.95</u>
<u>Maximum peak output power at antenna input terminal (mW):</u>	<u>62.3735</u>
<u>Prediction distance (cm):</u>	<u>20</u>
<u>Prediction frequency (MHz):</u>	<u>5785</u>
<u>Maximum Antenna Gain, typical (dBi):</u>	<u>18</u>
<u>Maximum Antenna Gain (numeric):</u>	<u>63.09573</u>
<u>Power density of prediction frequency at 20.0 cm (mW/cm²):</u>	<u>0.783</u>
<u>FCC MPE limit for uncontrolled exposure at prediction frequency (mW/cm²):</u>	<u>1.0</u>
<u>Power density of prediction frequency at 20.0 cm (W/m²):</u>	<u>7.83</u>
<u>IC MPE limit for uncontrolled exposure at prediction frequency (W/m²):</u>	<u>9.76</u>

The device is compliant with the requirement MPE limit for uncontrolled exposure. The maximum power density at the distance of 20 cm is 0.783 mW/cm² and 7.83 W/m². Limit is 1.0 mW/cm² for FCC and 9.76 W/m² for IC.

Case 2

<u>Maximum peak output power at antenna input terminal (dBm):</u>	<u>20.85</u>
<u>Maximum peak output power at antenna input terminal (mW):</u>	<u>121.6186</u>
<u>Prediction distance (cm):</u>	<u>20</u>
<u>Prediction frequency (MHz):</u>	<u>5755</u>
<u>Maximum Antenna Gain, typical (dBi):</u>	<u>15</u>
<u>Maximum Antenna Gain (numeric):</u>	<u>31.623</u>
<u>Power density of prediction frequency at 20.0 cm (mW/cm²):</u>	<u>0.765</u>
<u>FCC MPE limit for uncontrolled exposure at prediction frequency (mW/cm²):</u>	<u>1.0</u>
<u>Power density of prediction frequency at 20.0 cm (W/m²):</u>	<u>7.65</u>
<u>IC MPE limit for uncontrolled exposure at prediction frequency (W/m²):</u>	<u>9.72</u>

The device is compliant with the requirement MPE limit for uncontrolled exposure. The maximum power density at the distance of 20 cm is 0.765 mW/cm² and 7.65 W/m². Limit is 1.0 mW/cm² for FCC and 9.72 W/m² for IC.

Case 3

<u>Maximum peak output power at antenna input terminal (dBm):</u>	<u>20.36</u>
<u>Maximum peak output power at antenna input terminal (mW):</u>	<u>108.64</u>
<u>Prediction distance (cm):</u>	<u>20</u>
<u>Prediction frequency (MHz):</u>	<u>5785</u>
<u>Maximum Antenna Gain, typical (dBi):</u>	<u>15</u>
<u>Maximum Antenna Gain (numeric):</u>	<u>31.623</u>
<u>Power density of prediction frequency at 20.0 cm (mW/cm²):</u>	<u>0.684</u>
<u>FCC MPE limit for uncontrolled exposure at prediction frequency (mW/cm²):</u>	<u>1.0</u>
<u>Power density of prediction frequency at 20.0 cm (W/m²):</u>	<u>6.84</u>
<u>IC MPE limit for uncontrolled exposure at prediction frequency (W/m²):</u>	<u>9.8</u>

The device is compliant with the requirement MPE limit for uncontrolled exposure. The maximum power density at the distance of 20 cm is 0.684 mW/cm² and 6.84 W/m². Limit is 1.0 mW/cm² for FCC and 9.8 W/m² for IC.

5 FCC §15.203 & IC RSS-Gen §8.3 – Antenna Requirements

5.1 Applicable Standard

According to FCC §15.203:

An intentional radiator shall be designed to ensure that no antenna other than that furnished by the responsible party shall be used with the device. The use of a permanently attached antenna or of an antenna that uses a unique coupling to the intentional radiator shall be considered sufficient to comply with the provisions of this Section. The manufacturer may design the unit so that a broken antenna can be replaced by the user, but the use of a standard antenna jack or electrical connector is prohibited.

According to IC RSS-Gen §8.3: Transmitter Antenna

The applicant for equipment certification, as per RSP-100, must provide a list of all antenna types that may be used with the licence-exempt transmitter, indicating the maximum permissible antenna gain (in dBi) and the required impedance for each antenna.

Licence-exempt transmitters that have received equipment certification may operate with different types of antennas. However, it is not permissible to exceed the maximum equivalent isotropically radiated power (e.i.r.p.) limits specified in the applicable standard (RSS) for the licence-exempt apparatus.

Testing shall be performed using the highest gain antenna of each combination of licence-exempt transmitter and antenna type, with the transmitter output power set at the maximum level. When a measurement at the antenna connector is used to determine RF output power, the effective gain of the device's antenna shall be stated, based on a measurement or on data from the antenna manufacturer.

User manuals for transmitters equipped with detachable antennas shall also contain the following notice in a conspicuous location:

This radio transmitter (identify the device by certification number) has been approved by Industry Canada to operate with the antenna types listed below with the maximum permissible gain indicated. Antenna types not included in this list, having a gain greater than the maximum gain indicated for that type, are strictly prohibited for use with this device.

Immediately following the above notice, the manufacturer shall provide a list of all antenna types approved for use with the transmitter, indicating the maximum permissible antenna gain (in dBi).

5.2 Antenna Description

Antenna Type	Antenna Gain (dBi) @ 5 GHz
Internal Array	15
External Array	15

Note: Two polarization patch strip pairs per array. Internal array and external array do not active at the same time. Declared by manufacturer, the type, design, pattern and element for internal and external antenna are fully identical.

Case 1: EUT 4 antenna chains correlated to each other. The directional antenna gain is 15 dBi +10*log(2) = 18 dBi.

Directional antenna gain exceeds 6 dBi by 12 dB. FCC/IC limitation on output power and PSD are adjusted accordingly.

Case 2: EUT 4 antennas are fully un-correlated. The directional antenna gain is 15 dBi, which is 9 dB exceeds 6 dBi.

FCC/IC limitation on output power and PSD are adjusted accordingly.

Case 3: EUT 4 antennas are fully un-correlated. The directional antenna gain is 15 dBi, which is 9 dB exceeds 6 dBi.

FCC/IC limitation on output power and PSD are adjusted accordingly.

6 FCC §15.207 & IC RSS-Gen §8.8 - AC Power Line Conducted Emissions

6.1 Applicable Standards

As per FCC §15.207 and IC RSS-Gen §8.8 Conducted limits:

For an intentional radiator that is designed to be connected to the public utility (AC) power line, the radio frequency voltage that is conducted back onto the AC power line on any frequency or frequencies within the band 150 kHz to 30 MHz shall not exceed the limits in the following table, as measured using a 50 μ H/50 ohms line impedance stabilization network (LISN). Compliance with the provisions of this paragraph shall be based on the measurement of the radio frequency voltage between each power line and ground at the power terminal. The lower limit applies at the boundary between the frequencies ranges.

Frequency of Emission (MHz)	Conducted Limit (dBuV)	
	Quasi-peak	Average ^{Note 2}
0.15-0.5	66 to 56 ^{Note 1}	56 to 46 ^{Note 1}
0.5-5	56	46
5-30	60	50

Note 1 the level decreases linearly with the logarithm of the frequency.

Note 2 A linear average detector is required.

6.2 Test Setup

The measurement was performed at shield room, using the setup per ANSI C63.10-2013 measurement procedure. The specification used was FCC §15.207 and IC RSS-Gen §8.8 limits.

External I/O cables were draped along the edge of the test table and bundle when necessary.

The AC/DC power adapter of the EUT was connected with LISN-1 which provided 120 V / 60 Hz AC power.

6.3 Test Procedure

During the conducted emissions test, the power cord of the EUT host system was connected to the mains outlet of the LISN-1 and the power cord of the support equipment was connected to LISN-2.

Maximizing procedure was performed on the six (6) highest emissions of the EUT.

All data was recorded in the peak detection mode, quasi-peak and average. Quasi-Peak readings are distinguished with a "QP." Average readings are distinguished with an "Ave".

6.4 Test Setup Block Diagram

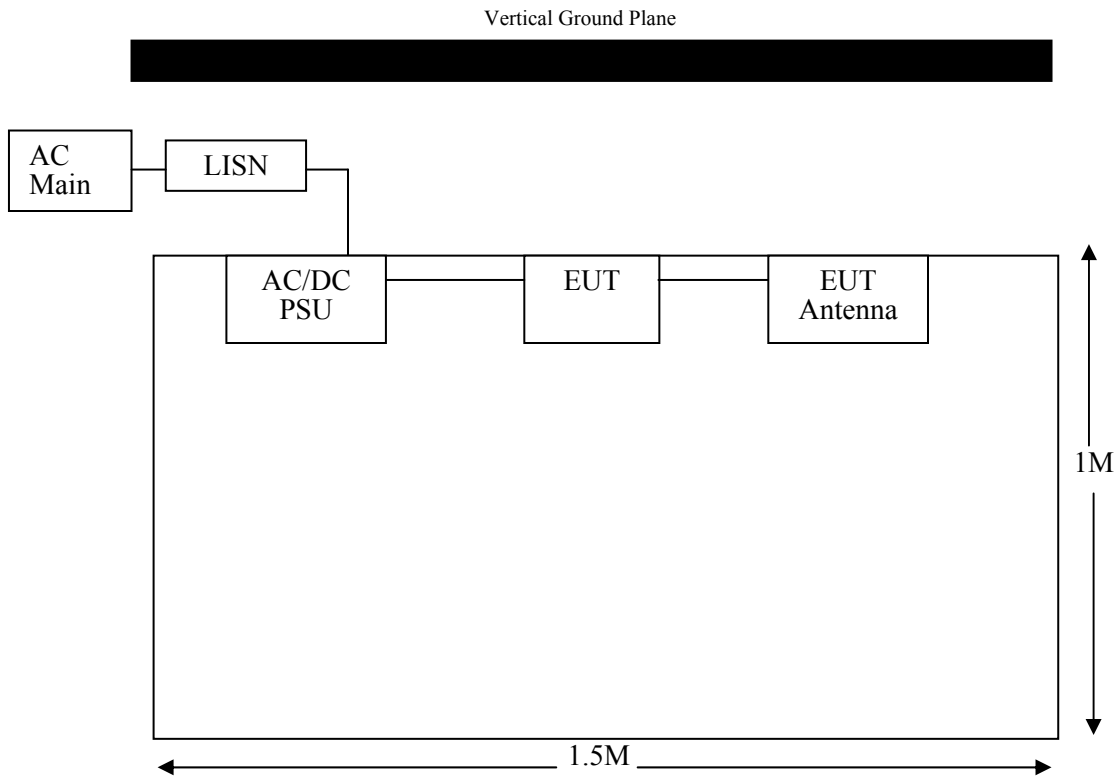

6.5 Corrected Amplitude & Margin Calculation

The Corrected Amplitude (CA) is calculated by adding the Cable Loss (CL), the Attenuator Factor (Atten) to indicated Amplitude (Ai) reading. The basic equation is as follows:

$$CA = A_i + CL + \text{Atten}$$

For example, a corrected amplitude of 46.2 dBuV = Indicated Reading (32.5 dBuV) + Cable Loss (3.7 dB) + Attenuator (10 dB)

The “**Margin**” column of the following data tables indicates the degree of compliance within the applicable limit. For example, a margin of -7 dB means the emission is 7 dB below the maximum limit. The equation for margin calculation is as follows:

$$\text{Margin} = \text{Corrected Amplitude} - \text{Limit}$$

6.6 Test Equipment List and Details

Manufacturer	Description	Model No.	Serial No.	Calibration Date	Calibration Interval
Rohde & Schwarz	Receiver, EMI Test	ESCI 1166.5950K03	100338	2014-01-20	2 year
FCC	LISN	FCC-LISN-50-2-10-CISPR16 1PA ANSI 14	160132	2015-04-07	1 year
Solar Electronics Company	High Pass Filter	Type 7930-100	7930150204	2015-03-06	1 year
Rohde & Schwarz	Impulse Limiter	ESH3-Z2	101963	2015-07-15	1 year
Suirong	30 ft conductive emission cable	LMR 400	-	Cal. Not Required	N/A
Hewlett-Packard	5 ft N-type RF cable	-	1268	Cal. Not Required	N/A

Statement of Traceability: *BACL Corp.* BACL Corp. attests that all of the calibrations on the equipment items listed above were traceable to NIST or to another internationally recognized National Metrology Institute (NMI), and were compliant with A2LA Policy P102 (dated 14 May 2015) "A2LA Policy on Metrological Traceability"..

6.7 Test Environmental Conditions

Temperature:	23° C
Relative Humidity:	46 %
ATM Pressure:	101.24 kPa

The testing was performed by Simon Ma on 2015-08-19 in 5m chamber3.

6.8 Summary of Test Results

According to the recorded data in following table, the EUT complied with the FCC 15C/IC RSS-Gen standard's conducted emissions limits, with the margin reading of:

Connection: AC/DC adapter connected to 120 V/60 Hz, AC			
Margin (dB)	Frequency (MHz)	Conductor Mode (Line/Neutral)	Range (MHz)
-10.68	0.194725	Neutral	0.15-30

6.9 Conducted Emissions Test Plots and Data

120 V, 60 Hz – Line

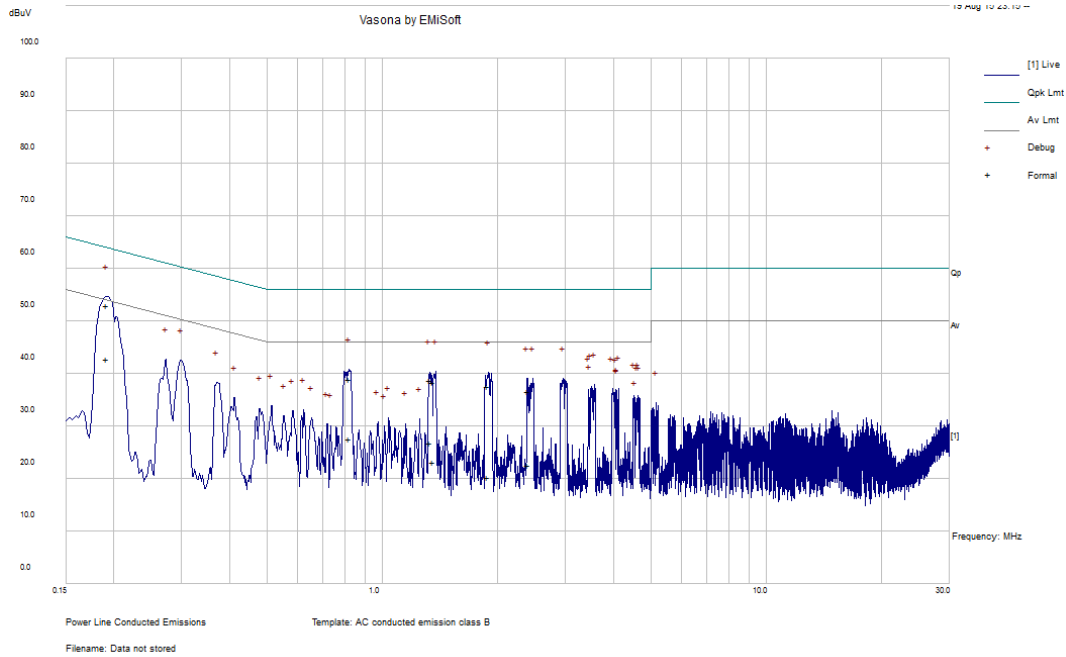

Frequency (MHz)	Corrected Amplitude (dBµV)	Conductor (Line/Neutral)	Limit (dBµV)	Margin (dB)	Detector (QP/Ave.)
0.191851	53.02	Line	63.96	-10.94	QP
0.818299	38.98	Line	56	-17.02	QP
1.359499	38.32	Line	56	-17.68	QP
1.327731	38.71	Line	56	-17.29	QP
1.884423	37.56	Line	56	-18.44	QP
2.396959	36.75	Line	56	-19.25	QP

Frequency (MHz)	Corrected Amplitude (dBµV)	Conductor (Line/Neutral)	Limit (dBµV)	Margin (dB)	Detector (QP/Ave.)
0.191851	42.87	Line	53.96	-11.09	Ave.
0.818299	27.59	Line	46	-18.41	Ave.
1.359499	23.14	Line	46	-22.86	Ave.
1.327731	26.82	Line	46	-19.18	Ave.
1.884423	20.32	Line	46	-25.68	Ave.
2.396959	22.7	Line	46	-23.3	Ave.

120 V, 60 Hz – Neutral

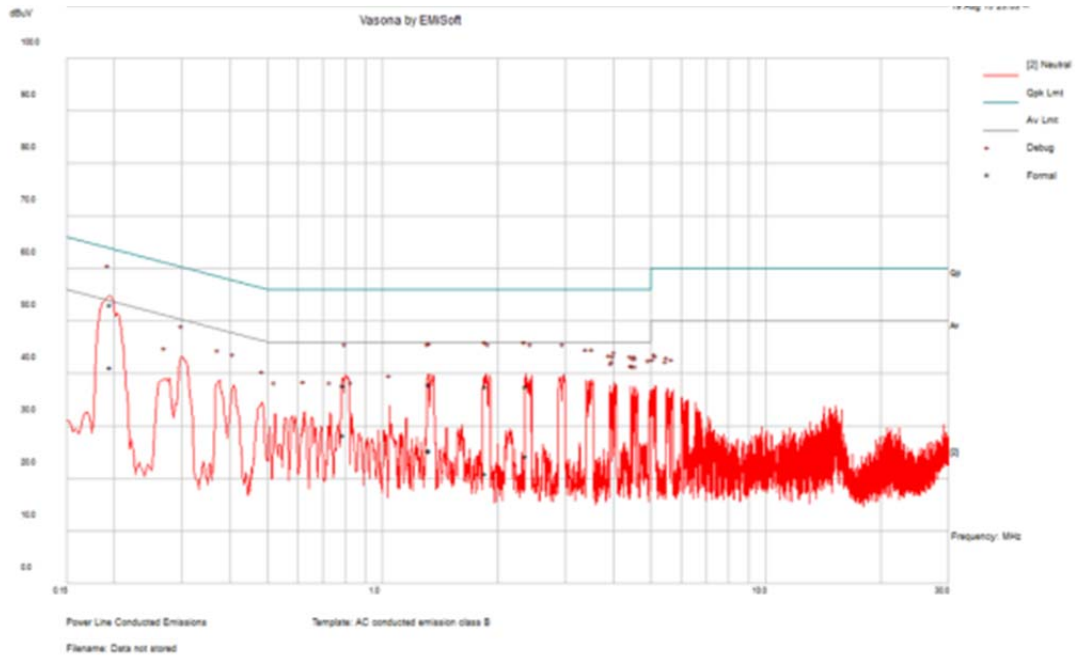

Frequency (MHz)	Corrected Amplitude (dBµV)	Conductor (Line/Neutral)	Limit (dBµV)	Margin (dB)	Detector (QP/Ave.)
0.194725	53.15	Neutral	63.83	-10.68	QP
2.366522	37.71	Neutral	56	-18.29	QP
1.858011	37.68	Neutral	56	-18.32	QP
1.323685	37.94	Neutral	56	-18.06	QP
1.324769	37.94	Neutral	56	-18.06	QP
0.793056	37.88	Neutral	56	-18.12	QP

Frequency (MHz)	Corrected Amplitude (dBµV)	Conductor (Line/Neutral)	Limit (dBµV)	Margin (dB)	Detector (QP/Ave.)
0.194725	41.32	Neutral	53.83	-12.51	Ave.
2.366522	24.36	Neutral	46	-21.64	Ave.
1.858011	21.1	Neutral	46	-24.9	Ave.
1.323685	25.32	Neutral	46	-20.68	Ave.
1.324769	25.53	Neutral	46	-20.47	Ave.
0.793056	28.37	Neutral	46	-17.63	Ave.

7 FCC §15.209, §15.407(b) & IC RSS-247 §6.2.4 (2) - Spurious Radiated Emissions

Please Refer to report number: 15U21301-E1 released by UL Verification Services INC. on June 23, 2015.

8 FCC §15.407(a), §15.407(e) & IC RSS-Gen §6.6, RSS-247 §6.2.4 (1) – Emission Bandwidth

8.1 Applicable Standards

According to FCC §15.407(e) and IC RSS-247 §6.2.4(1)

Within the 5.725-5.85 GHz band, the minimum 6 dB Bandwidth of U-NII devices shall be at least 500 kHz.

8.2 Measurement Procedure

The measurements are based on FCC KDB 789033 D02 General UNII Test Procedures New Rules v01: Guidelines for Compliance Testing of Unlicensed National Information Infrastructure (U-NII) Devices section C: Emission bandwidth and section D: 99 % Occupied Bandwidth

8.3 Test Equipment List and Details

Manufacturer	Description	Model No.	Serial No.	Calibration Date	Calibration Interval
R & S	Signal Analyzer	FSQ	1155.5001.26	2015-03-09	1 year
Agilent	Analyser Spectrom	E4440A	US 42221851	2015-06-23	1 year
-	SMA cable	-	C0002-6	Each time ¹	N/A
Mini-Circuits	Combiner	ZN8PD-642W-S+	SF584201336	Each time ¹	N/A

Note¹: cable and attenuator included in the test set-up will be checked each time before testing.

Statement of Traceability: *BACL Corp.* *BACL Corp.* attests that all of the calibrations on the equipment items listed above were traceable to NIST or to another internationally recognized National Metrology Institute (NMI), and were compliant with A2LA Policy P102 (dated 14 May 2015) "A2LA Policy on Metrological Traceability".

8.4 Test Environmental Conditions

Temperature:	21 - 25° C
Relative Humidity:	43 - 45%
ATM Pressure:	101.5-105.2 kPa

The testing was performed by Simon Ma from 2015-08-15 to 2015-08-19 at RF site.

8.5 Test Results

Please refer to the following tables and plots.

Case 1

Channel	Frequency (MHz)	99% OBW (MHz)				6 dB OBW (MHz)			
		Ant 1	Ant 2	Ant 3	Ant 4	Ant 1	Ant 2	Ant 3	Ant 4
Low	5745	18.94	19.04	18.89	18.84	17.88	17.67	17.34	17.86
Middle	5785	18.99	18.94	19.04	18.89	17.63	17.56	17.64	17.87
High	5835	18.7	18.7	18.7	18.7	17.63	17.58	17.87	17.59

Case 2

Channel	Frequency (MHz)	99% OBW (MHz)		6 dB OBW (MHz)	
		Ant 1&3	Ant 2&4	Ant 1&3	Ant 2&4
Low	5755	38.06	38.06	37.40	37.50
Middle	5785	37.95	37.95	37.69	37.53
High	5825	37.95	37.95	37.28	36.99

Case 3

Channel	Frequency (MHz)	99% OBW (MHz)				6 dB OBW (MHz)			
		Ant 1	Ant 2	Ant 3	Ant 4	Ant 1	Ant 2	Ant 3	Ant 4
Low	5745	18.89	18.89	18.89	18.89	17.87	17.83	17.46	17.47
Middle	5785	18.89	19.00	18.75	18.75	17.51	17.93	17.59	17.63
High	5835	18.80	18.75	18.75	18.75	17.58	17.63	17.41	17.68

99% Occupied Bandwidth

Case 1 – Low Channel – 5745 MHz Antenna 1

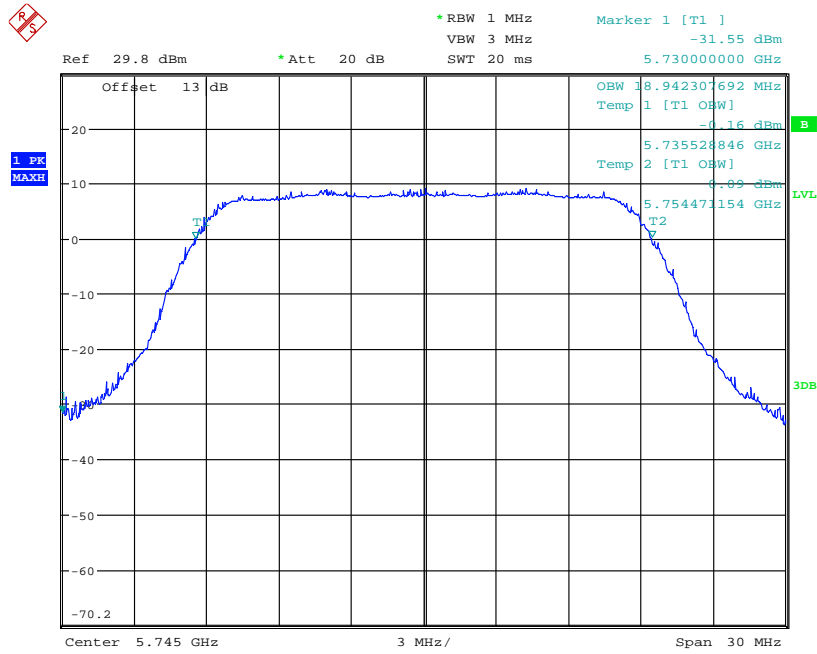

Date: 14.AUG.2015 23:00:43

Antenna 2

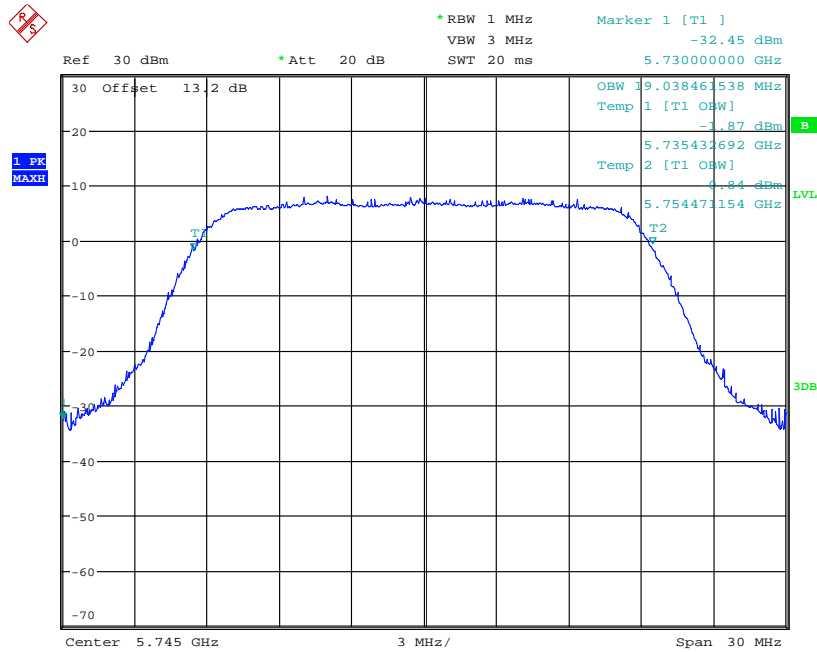

Date: 14.AUG.2015 22:59:04

Antenna 3

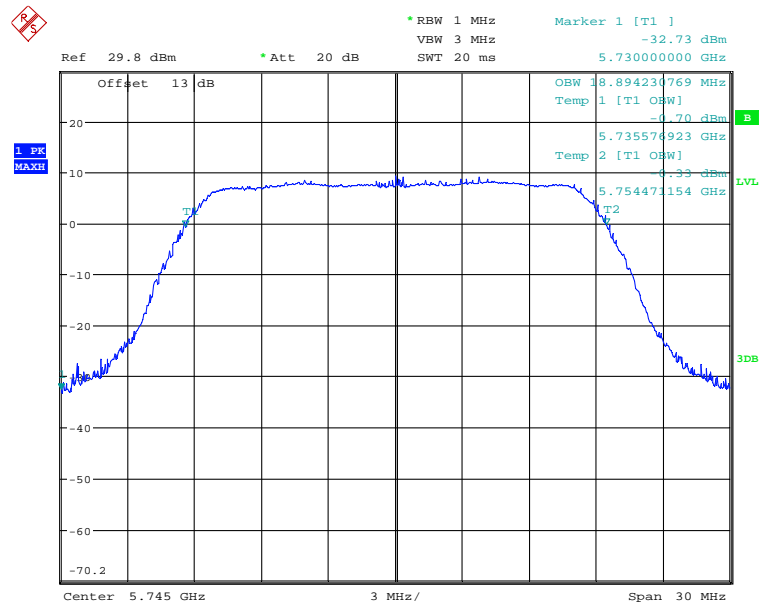

Date: 14.AUG.2015 23:01:39

Antenna 4

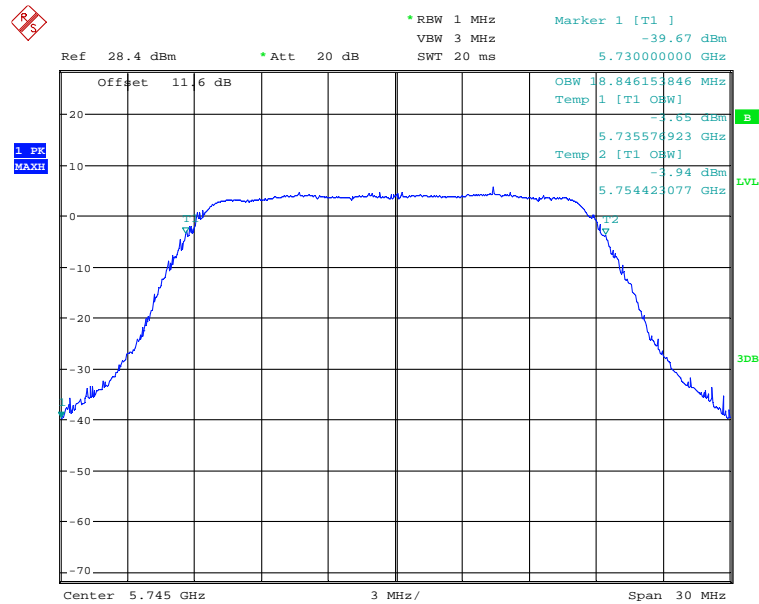

Date: 14.AUG.2015 23:02:23

Case 1 – Middle Channel – 5785 MHz

Antenna 1

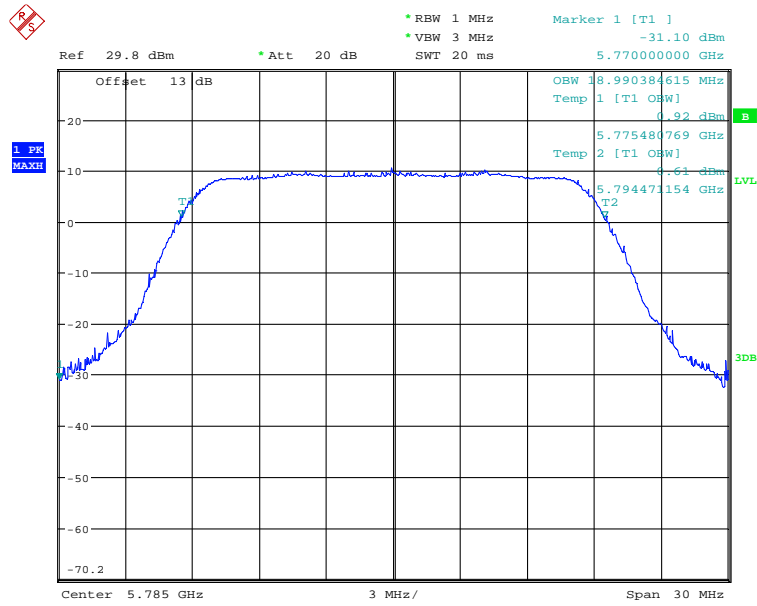

Date: 15.AUG.2015 13:46:33

Antenna 2

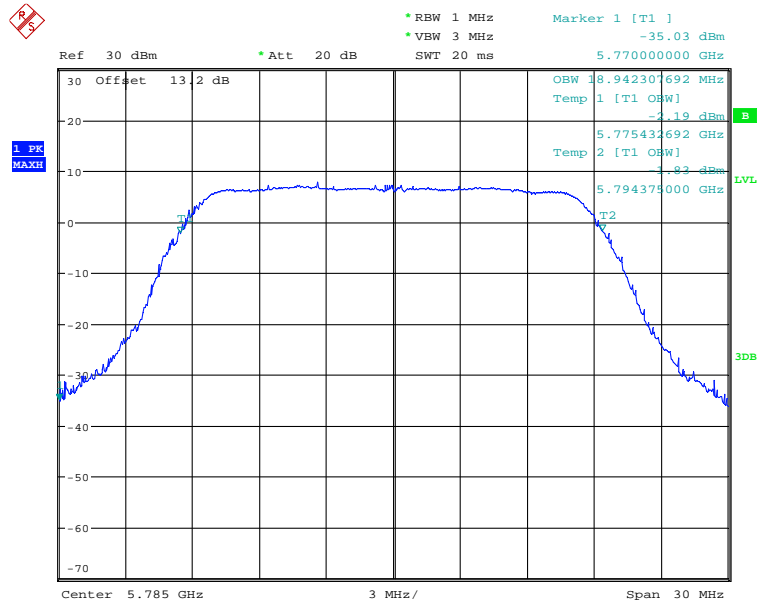

Date: 15.AUG.2015 13:49:06

Antenna 3

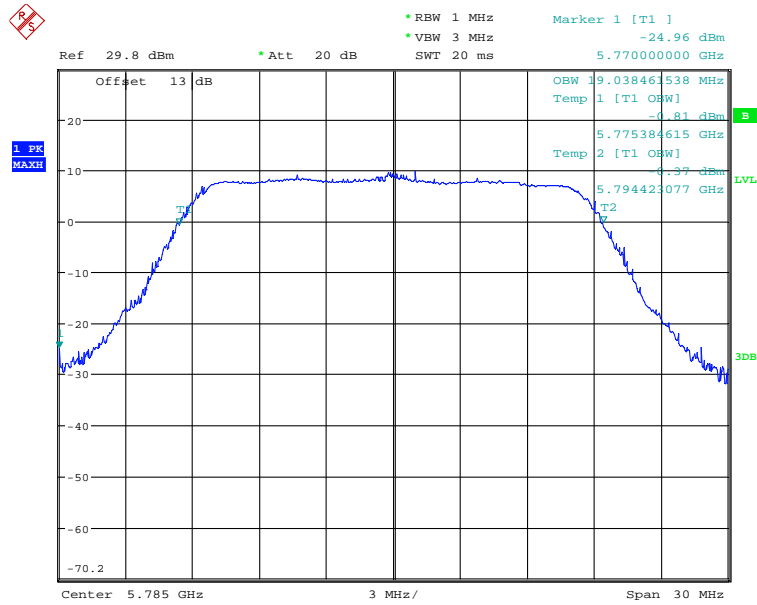

Date: 15.AUG.2015 13:47:58

Antenna 4

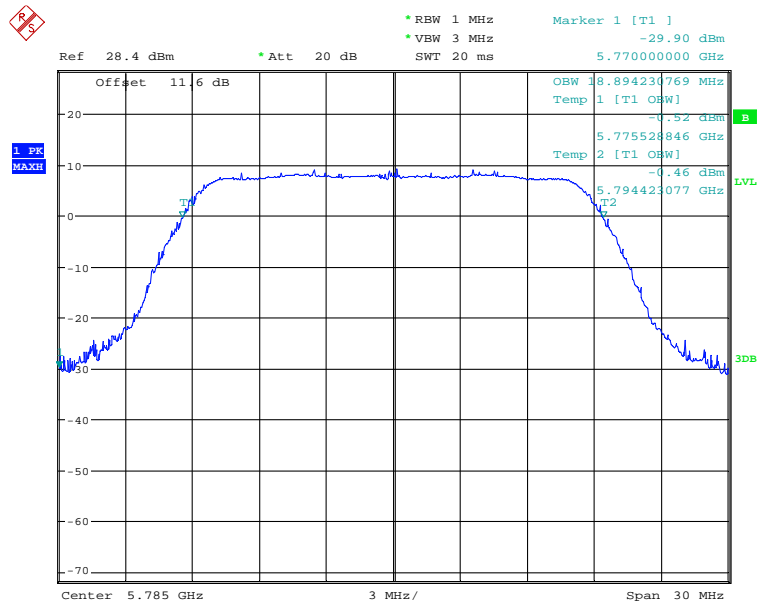

Date: 15.AUG.2015 13:48:32

Case 1 – High Channel – 5835 MHz

Antenna 1

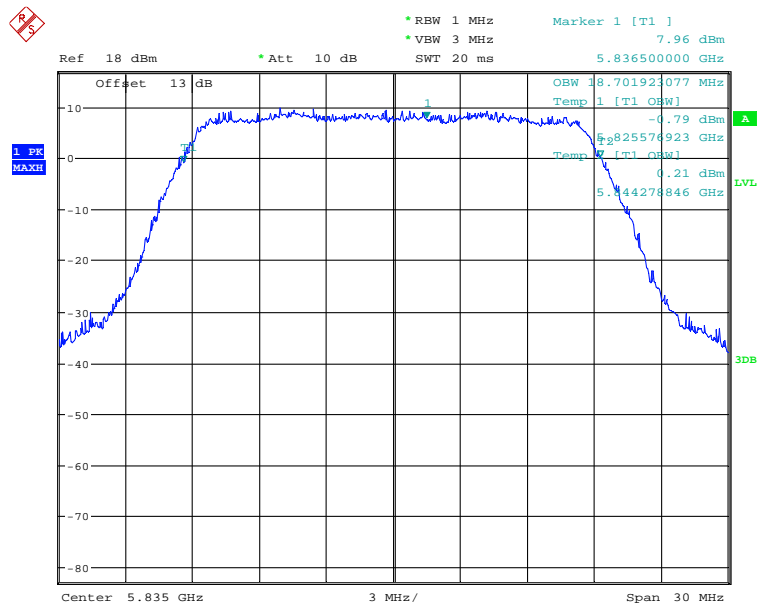

Date: 27.SEP.2015 18:10:16

Antenna 2

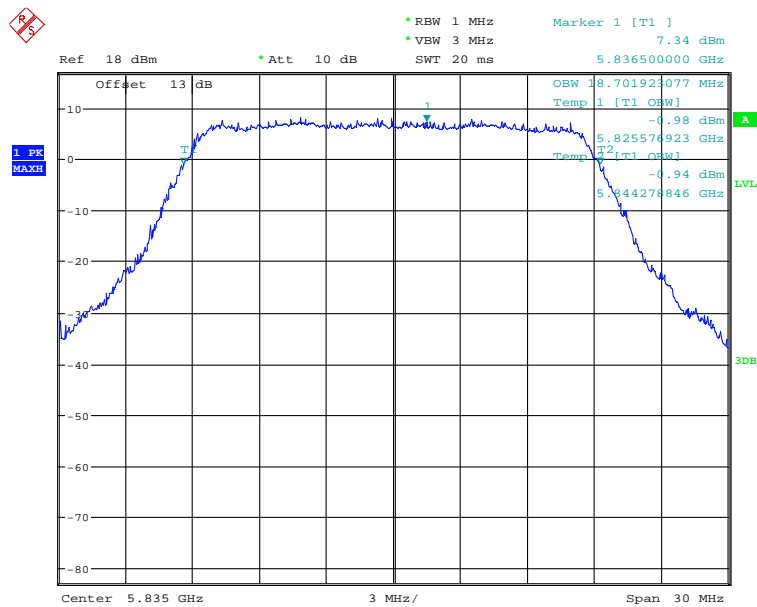

Date: 27.SEP.2015 18:12:31

Antenna 3

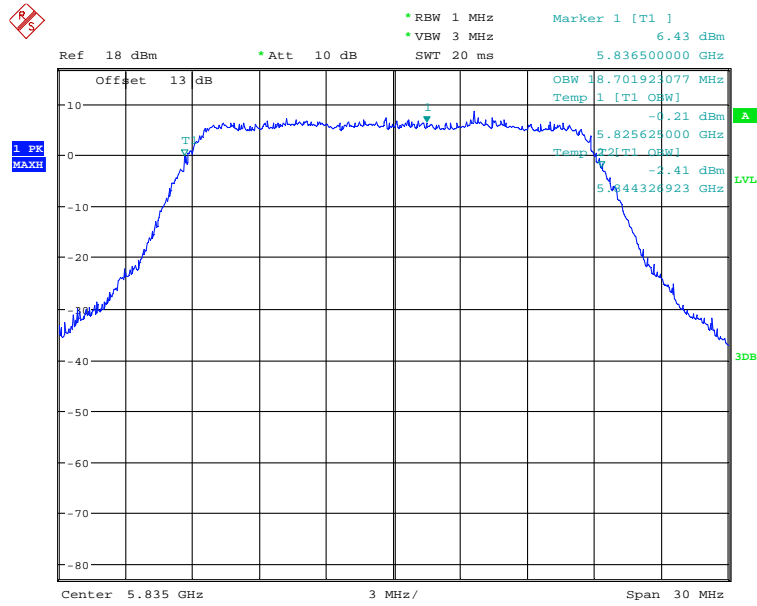

Date: 27.SEP.2015 18:13:23

Antenna 4

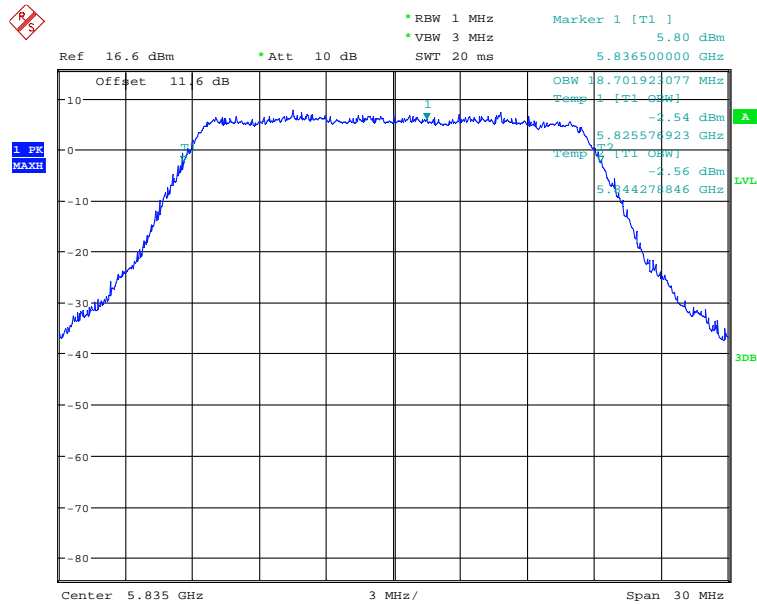

Date: 27.SEP.2015 18:14:00

Case 2 – Low Channel – 5755 MHz

Antenna 1 & 3

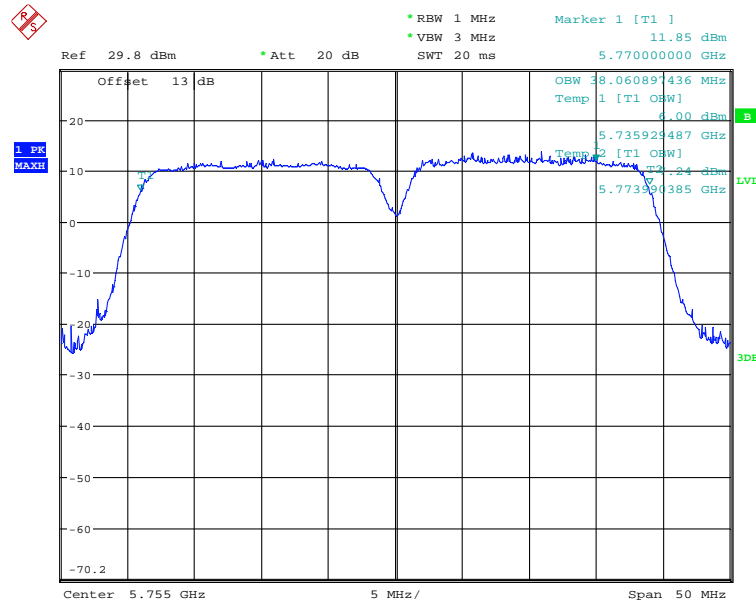

Date: 15.AUG.2015 17:32:01

Antenna 2 & 4

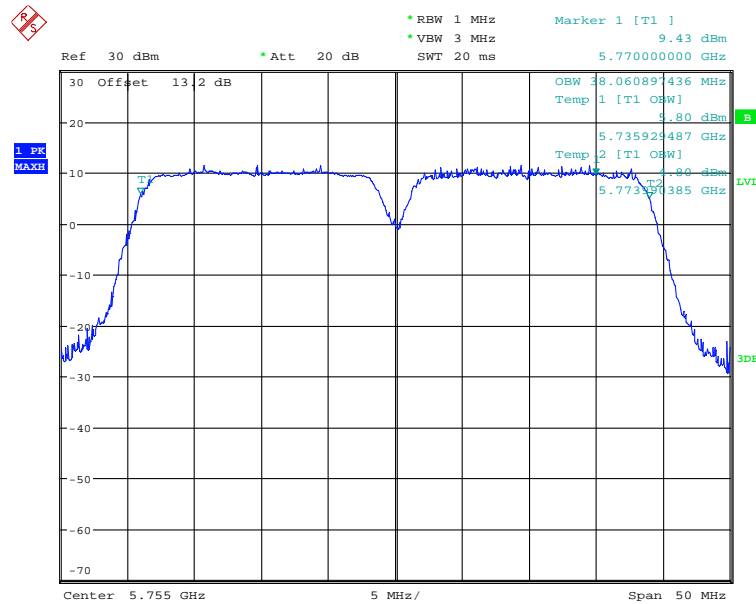

Date: 15.AUG.2015 17:31:16

Case 2 – Middle Channel – 5785 MHz

Antenna 1 & 3

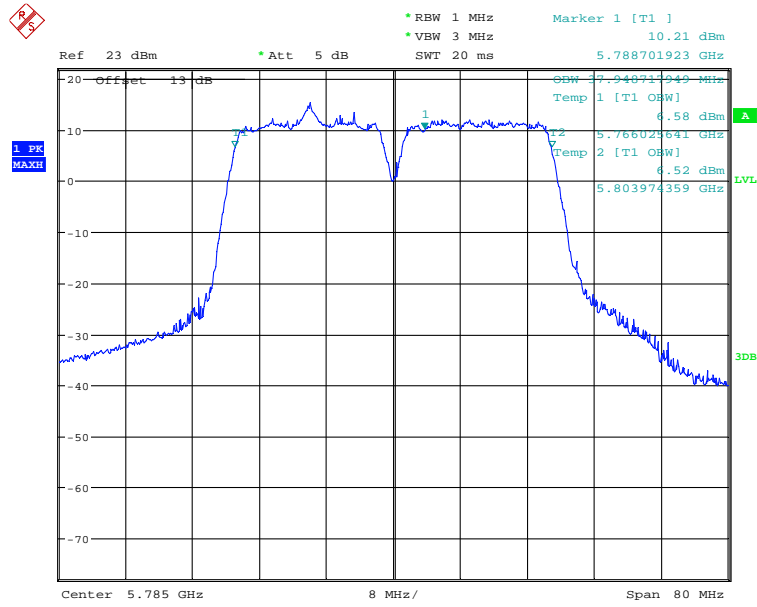

Date: 27.SEP.2015 12:42:59

Antenna 2 & 4

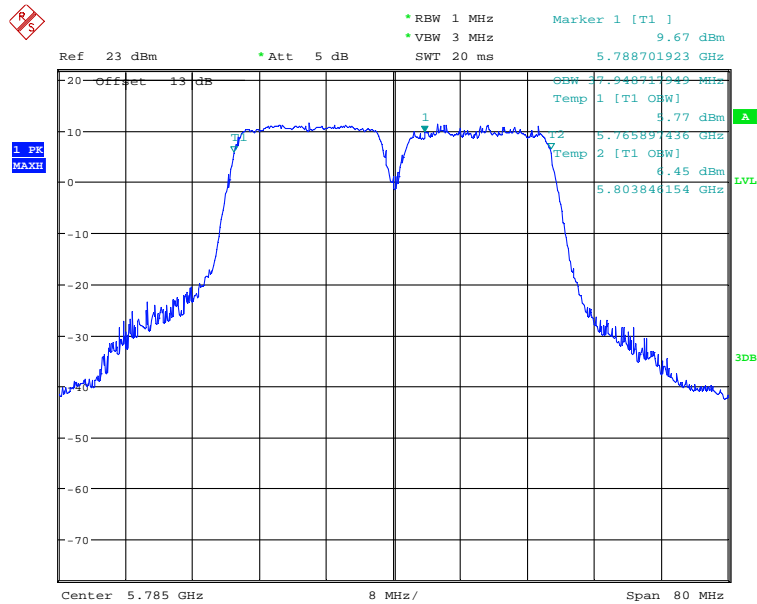

Date: 27.SEP.2015 12:51:50

Case 2 – High Channel – 5825 MHz

Antenna 1 & 3

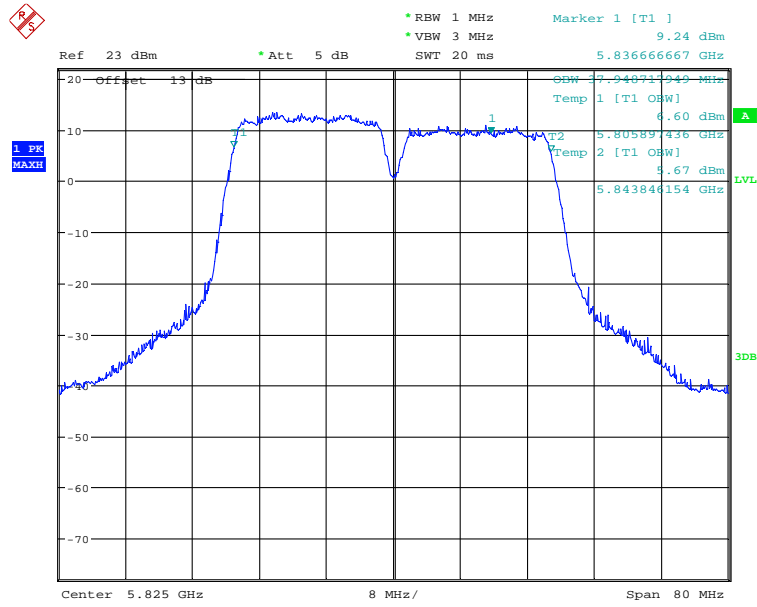

Date: 25.SEP.2015 22:38:35

Antenna 2 & 4

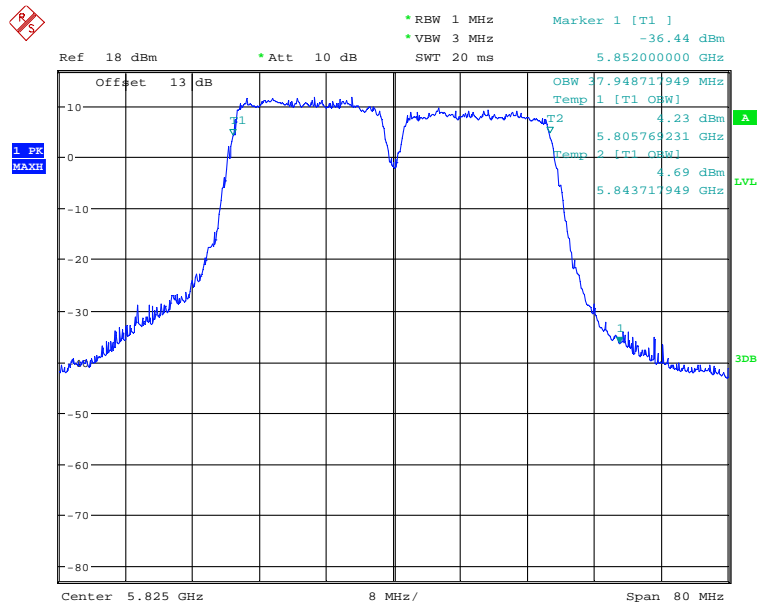

Date: 27.SEP.2015 17:32:46

Case 3 – Low Channel – 5745 MHz

Antenna 1

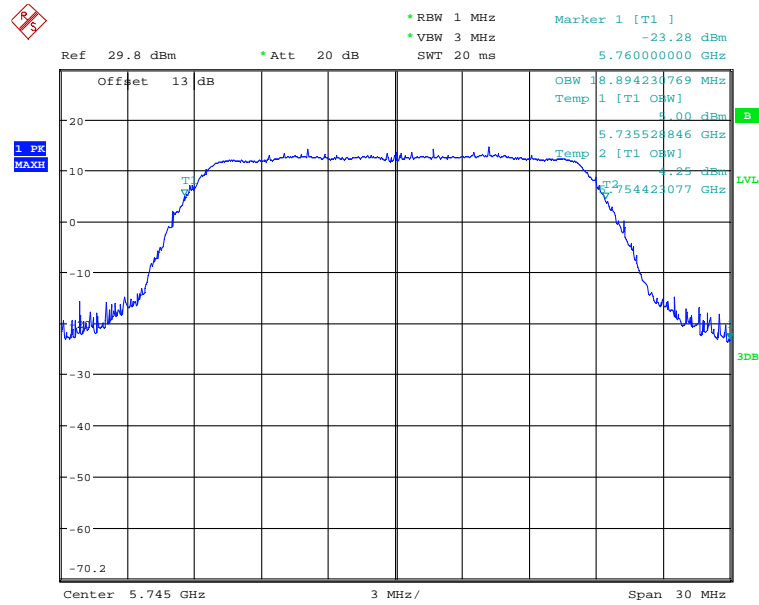

Date: 15.AUG.2015 15:45:56

Antenna 2

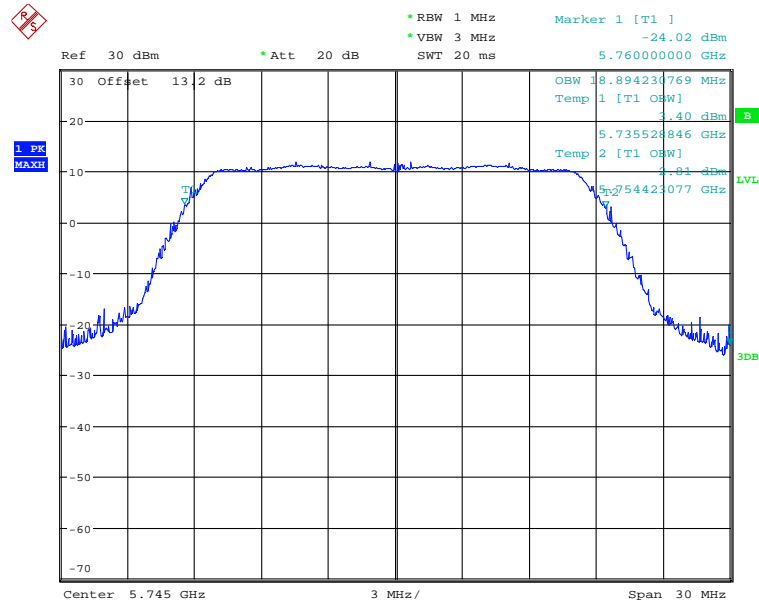

Date: 15.AUG.2015 15:46:53

Antenna 3

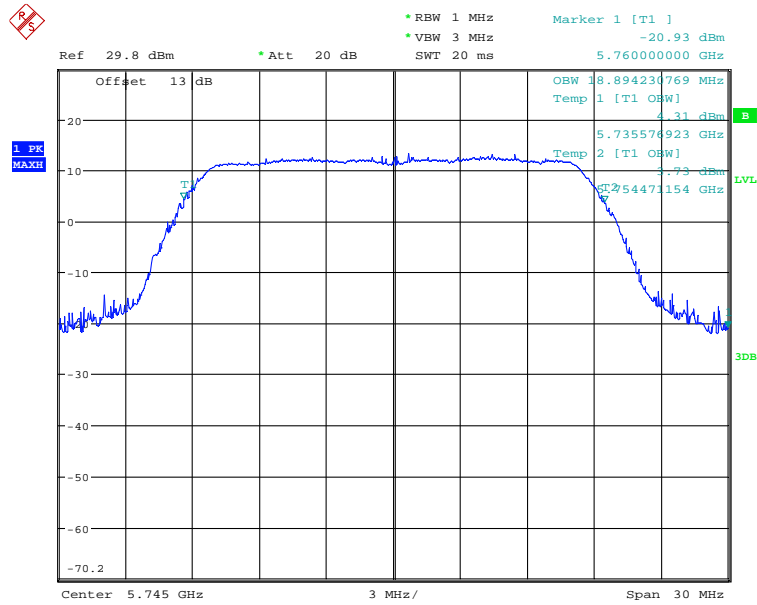

Date: 15.AUG.2015 15:47:26

Antenna 4

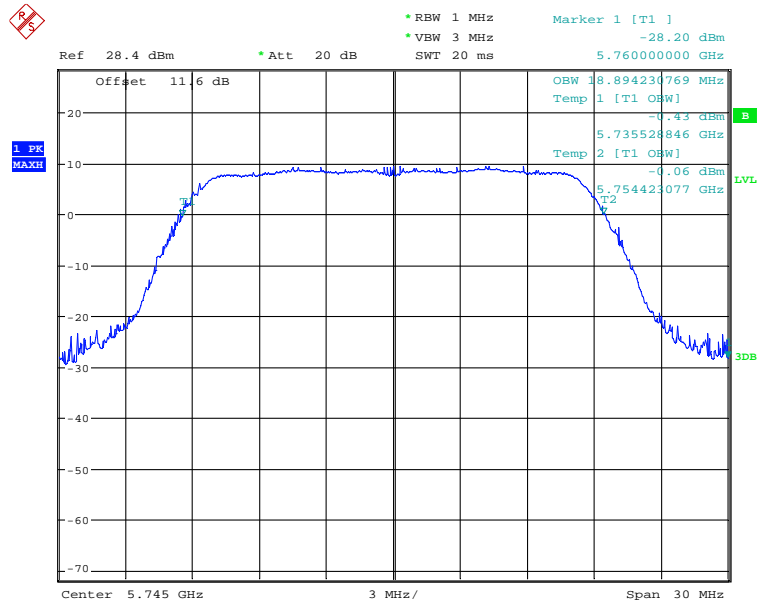

Date: 15.AUG.2015 15:48:02

Case 3 – Middle Channel – 5785 MHz

Antenna 1

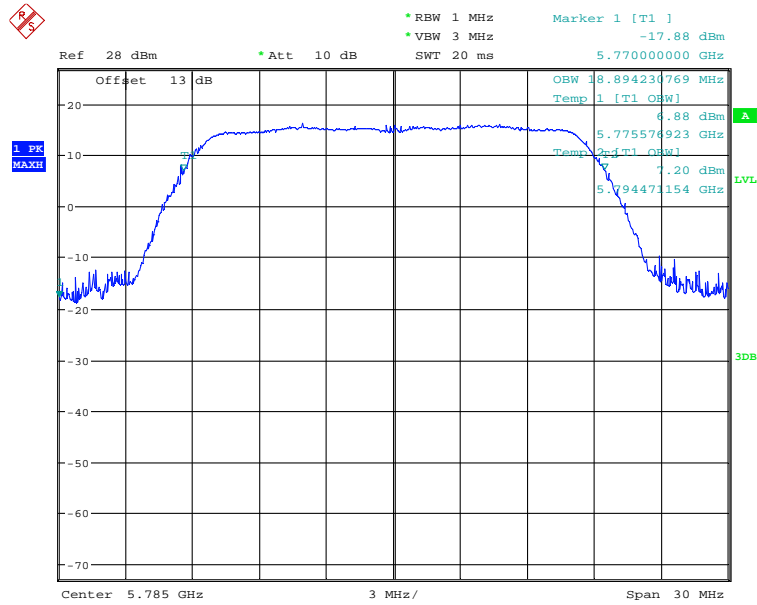

Date: 25.SEP.2015 22:52:24

Antenna 2

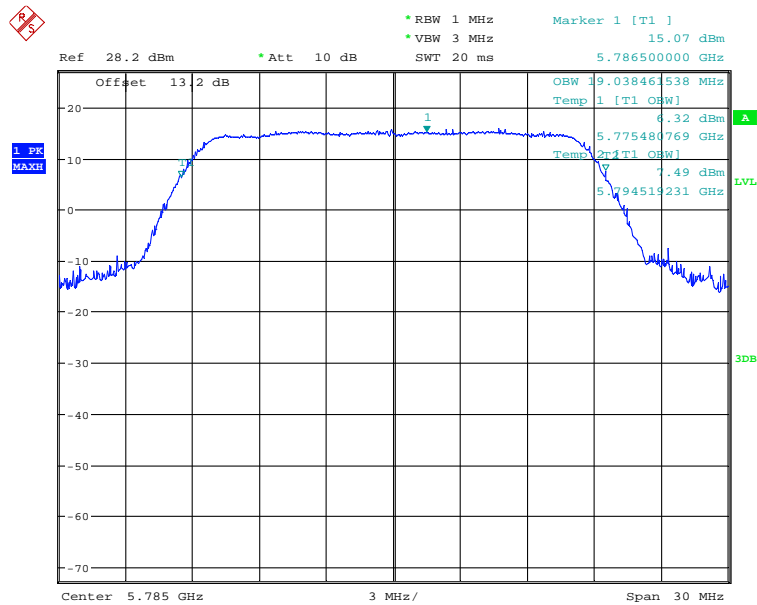

Date: 25.SEP.2015 22:57:53

Antenna 3

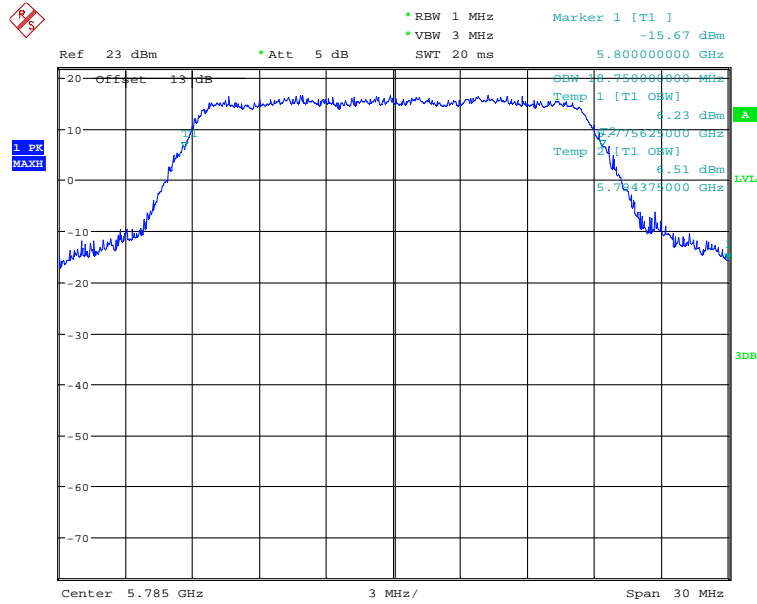

Date: 25.SEP.2015 23:14:07

Antenna 4

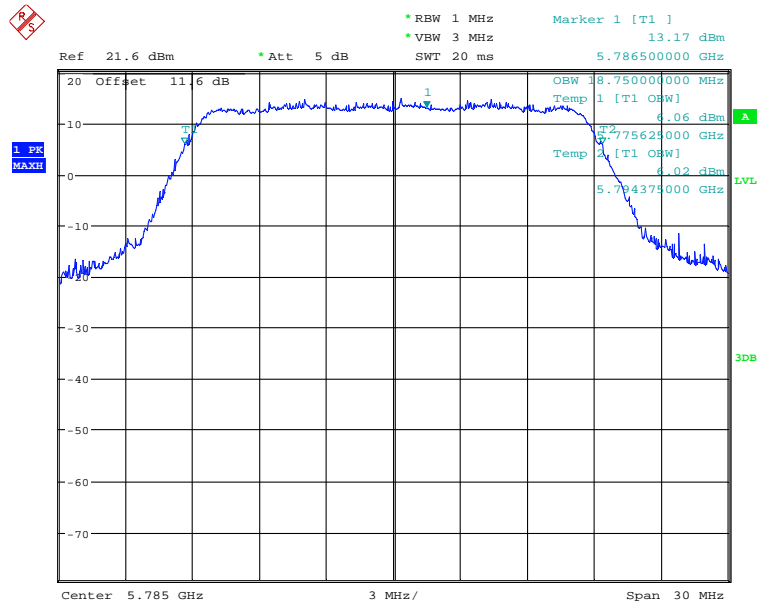

Date: 25.SEP.2015 23:21:37

Case 3 – High Channel – 5835 MHz

Antenna 1

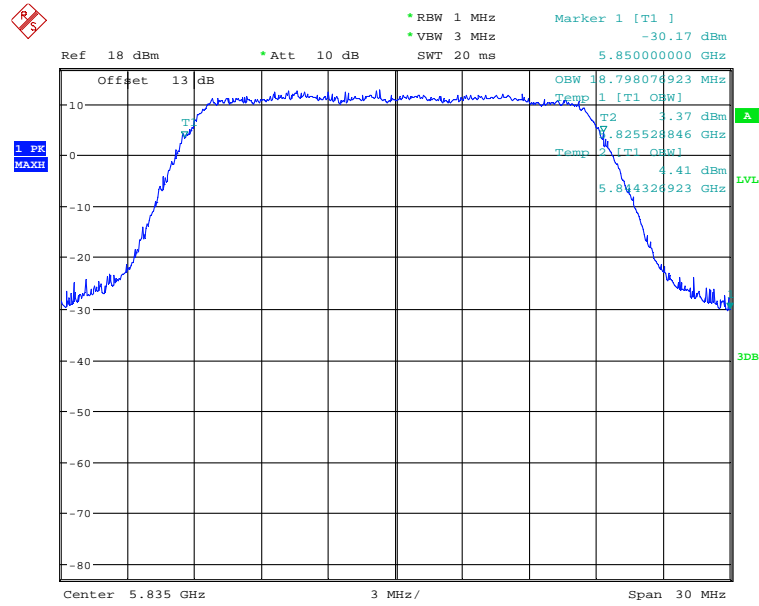

Date: 27.SEP.2015 13:36:20

Antenna 2

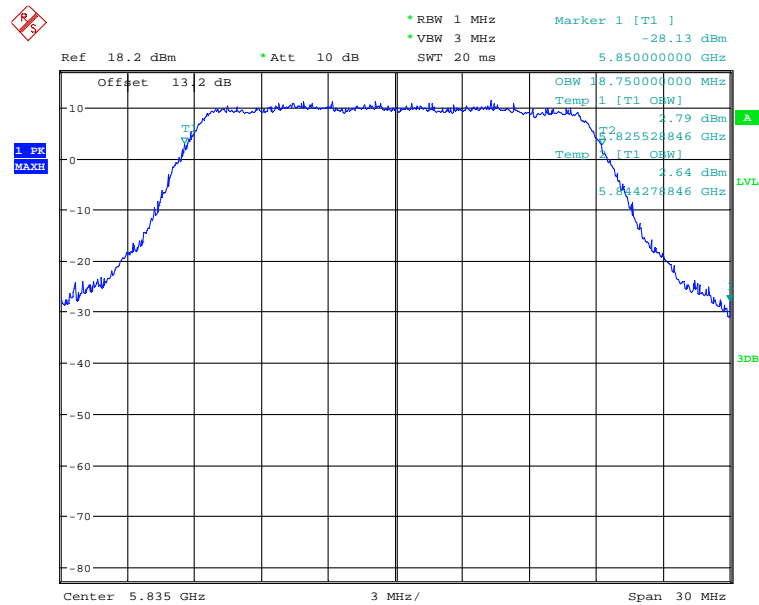

Date: 27.SEP.2015 13:38:29

Antenna 3

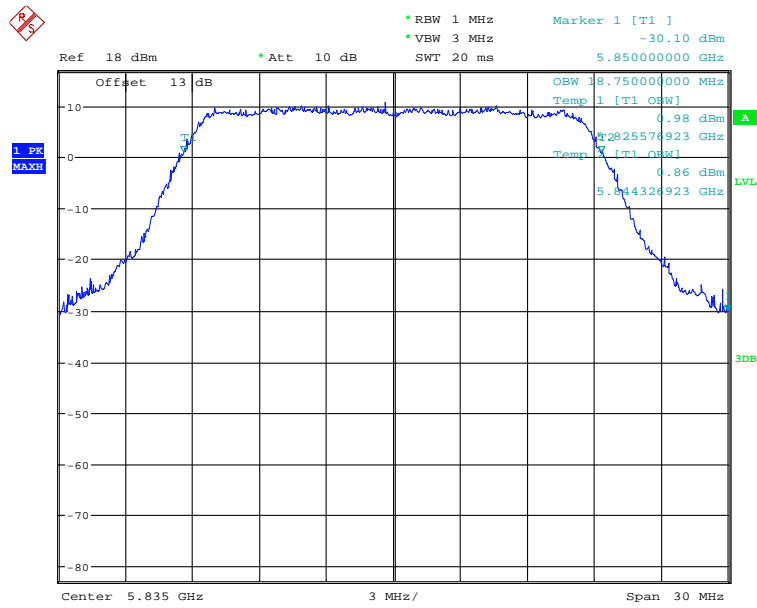

Date: 27.SEP.2015 13:39:12

Antenna 4

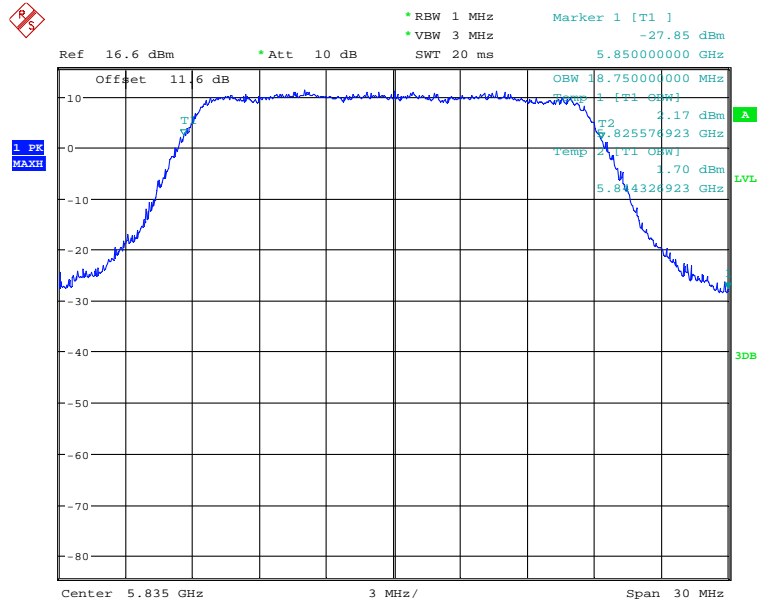

Date: 27.SEP.2015 13:39:54

6 dB Emission Bandwidth

Case 1 – Low Channel – 5745 MHz

Antenna 1

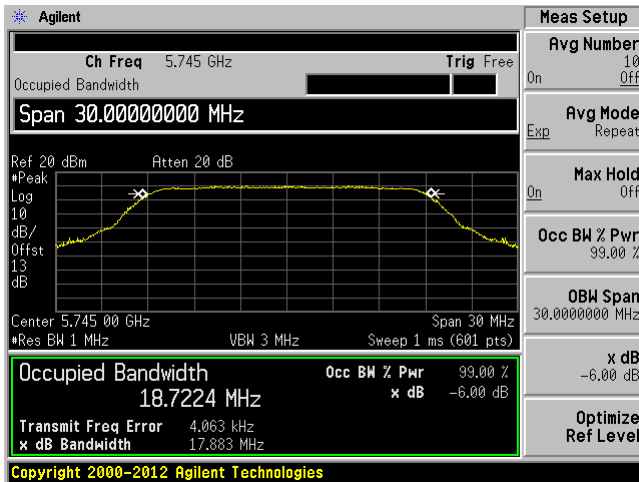

Antenna 2

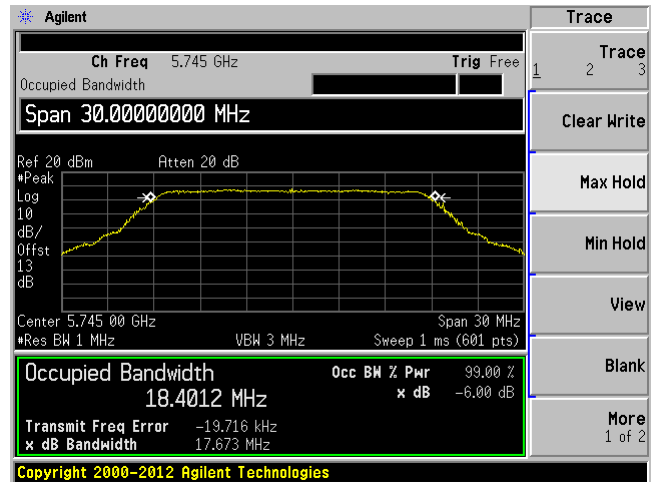

Antenna 3

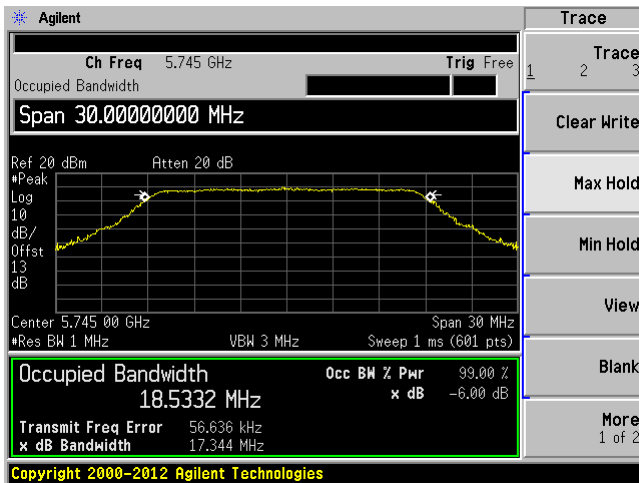

Antenna 4

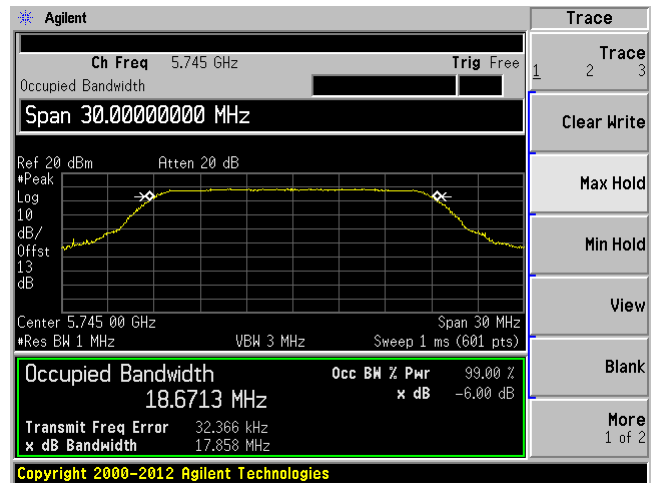

Case 1 – Middle Channel – 5785 MHz

Antenna 1

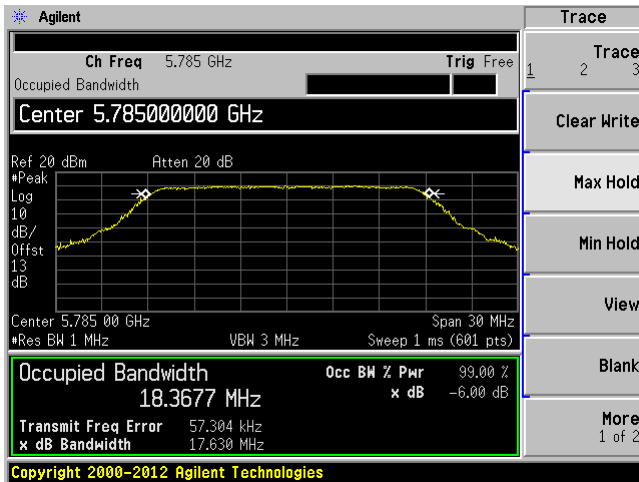

Antenna 2

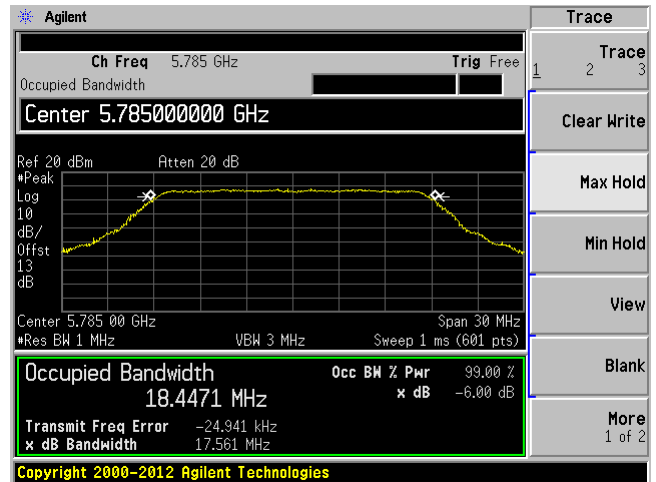

Antenna 3

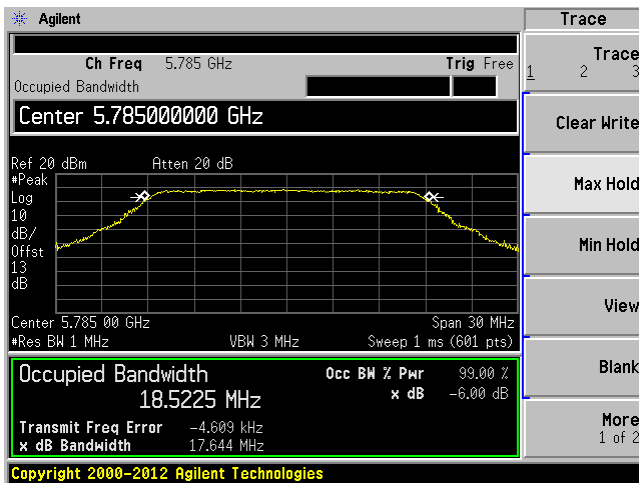

Antenna 4

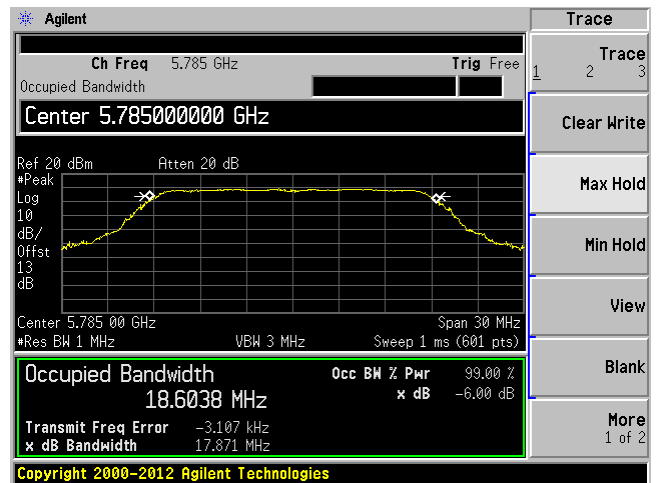

Case 1 – High Channel – 5835 MHz

Antenna 1

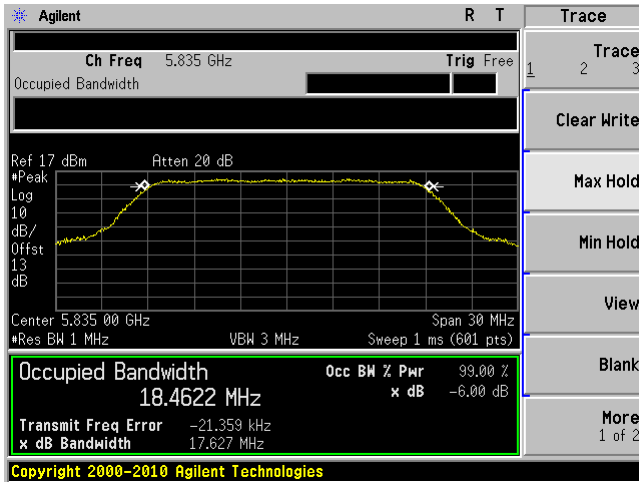

Antenna 2

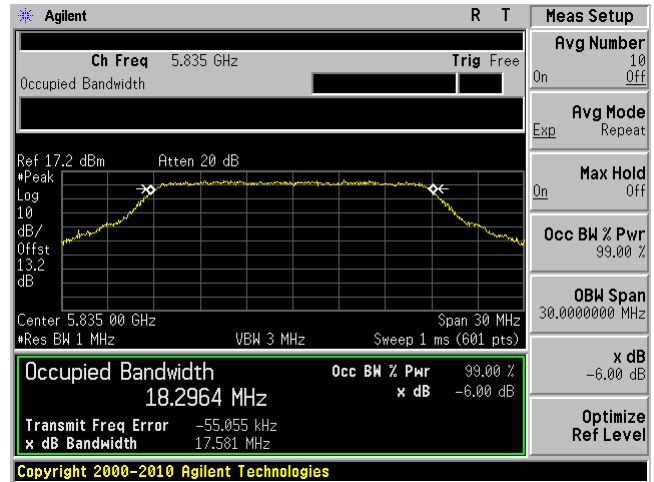

Antenna 3

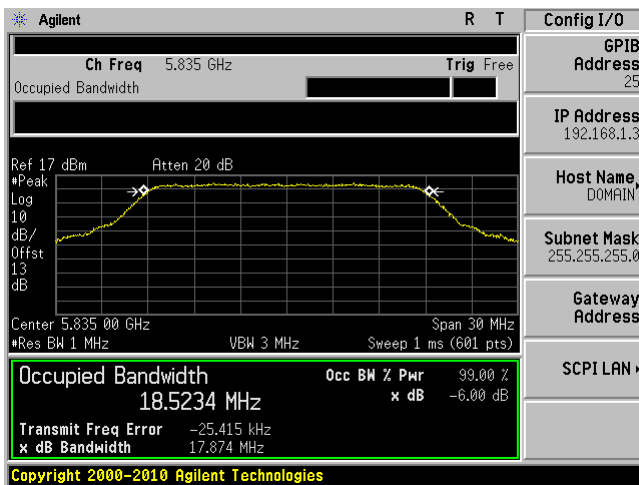

Antenna 4

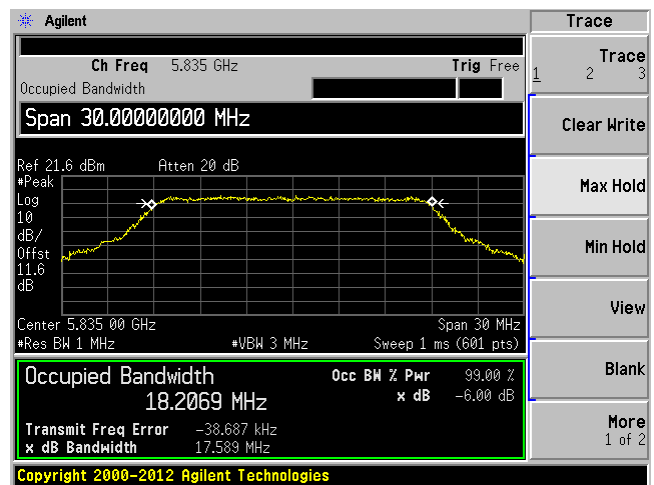

Case 2 – Low Channel – 5755 MHz

Antenna 1 & 3

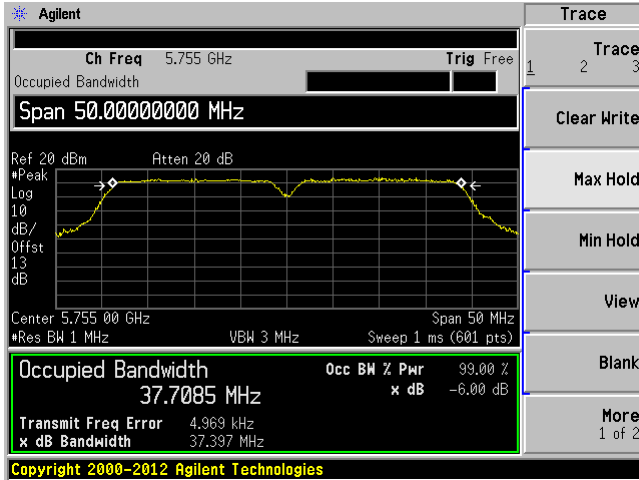

Antenna 2 & 4

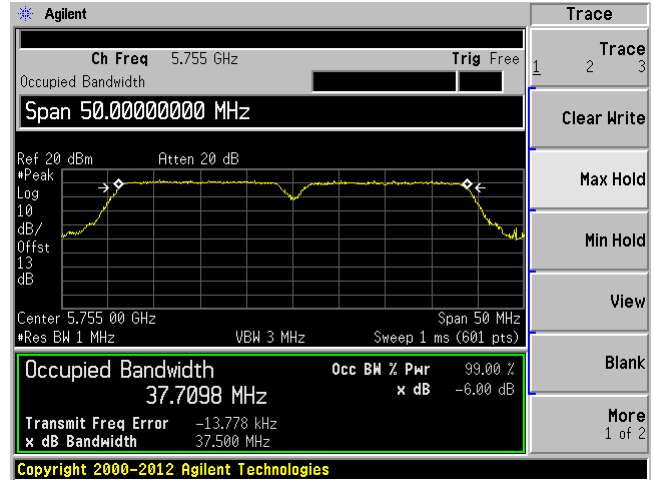

Case 2 – Middle Channel – 5785 MHz

Antenna 1 & 3

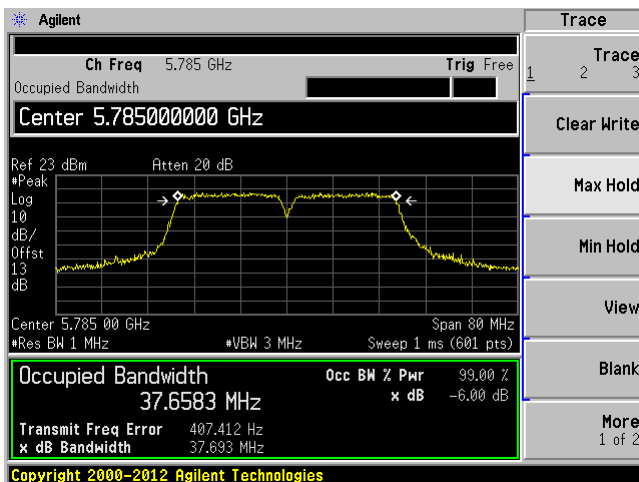

Antenna 2 & 4

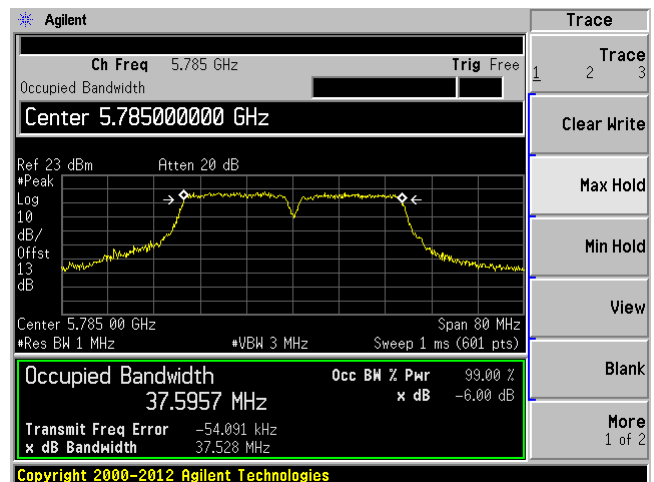

Case 2 – High Channel – 5825 MHz

Antenna 1 & 3

Antenna 2 & 4

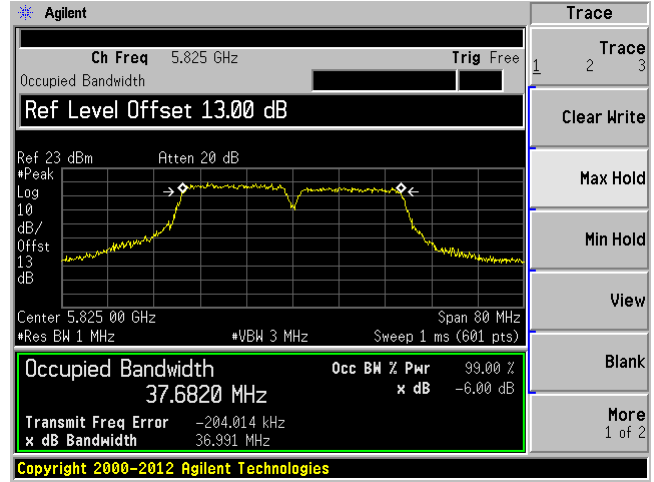
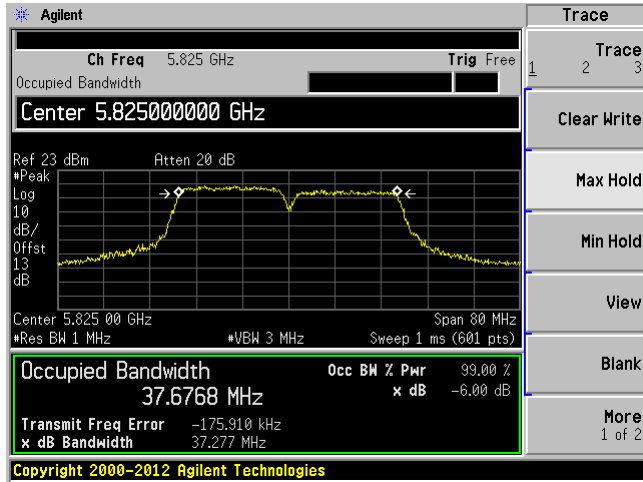

Case 3 – Low Channel – 5745 MHz

Antenna 1

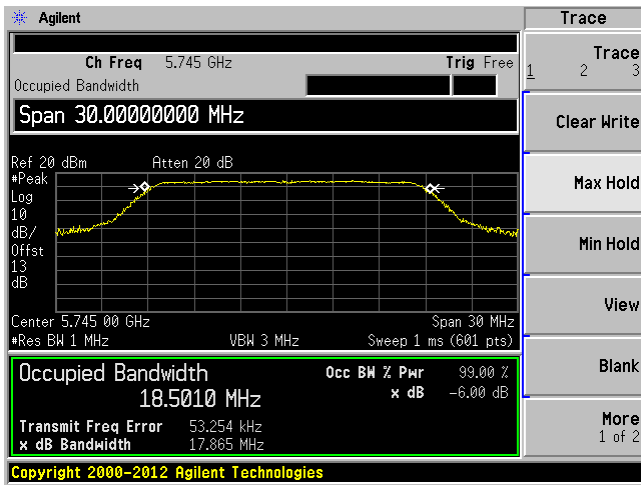

Antenna 2

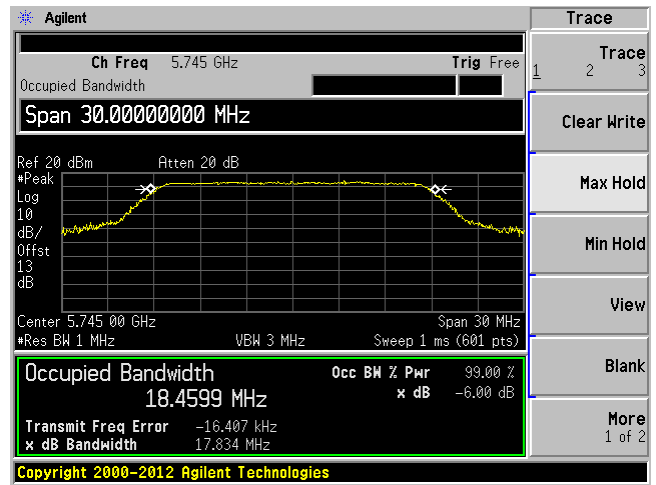

Antenna 3

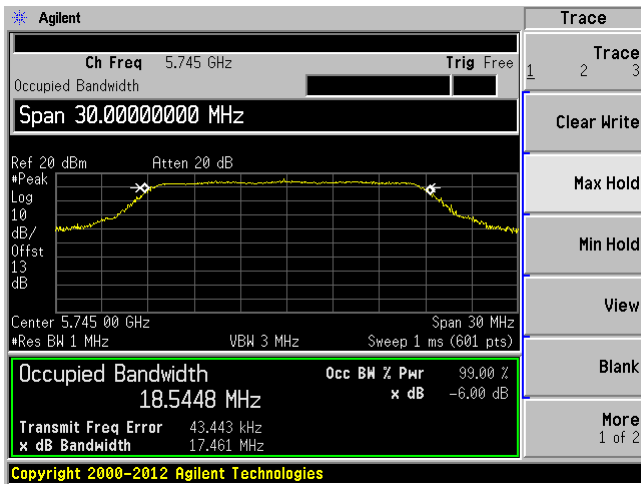

Antenna 4

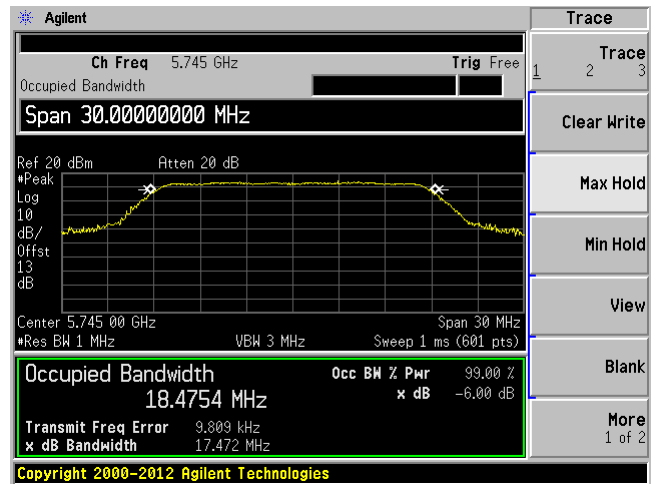

Case 3 – Middle Channel – 5785 MHz

Antenna 1

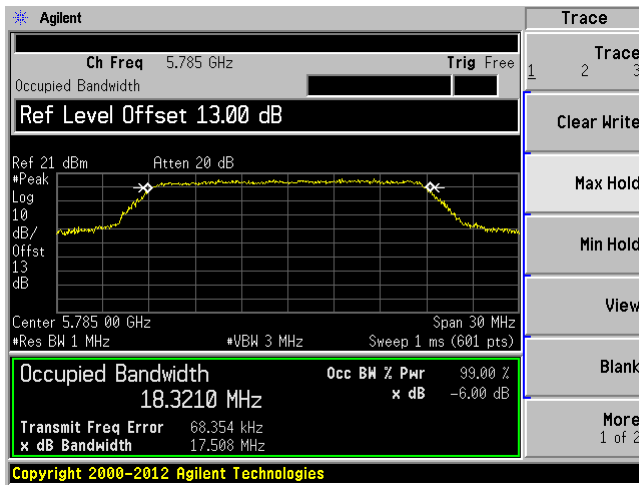

Antenna 2

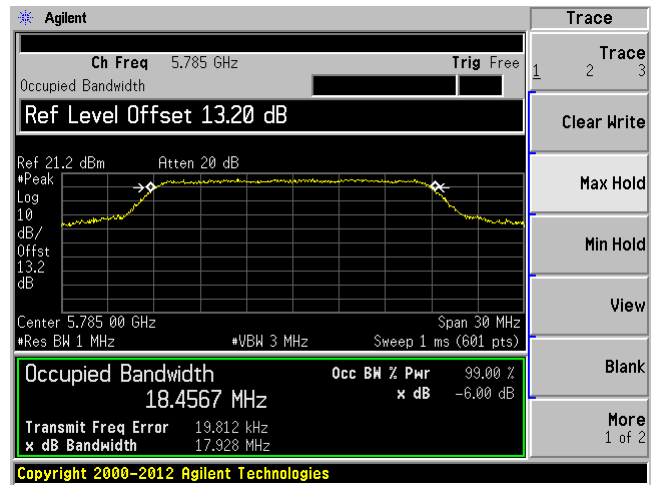

Antenna 3

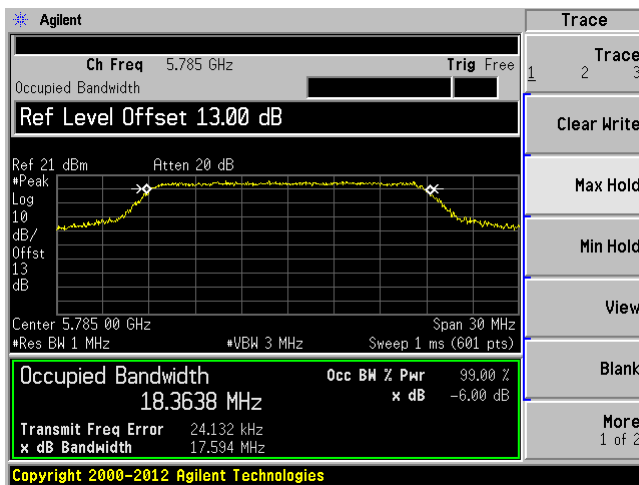

Antenna 4

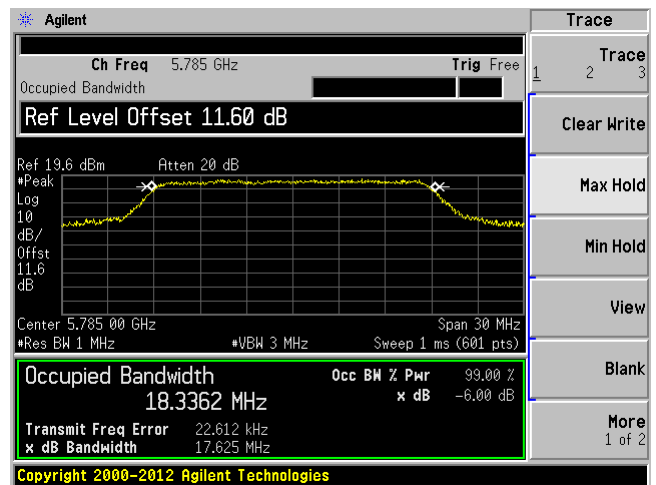

Case 3 – High Channel – 5835 MHz

Antenna 1

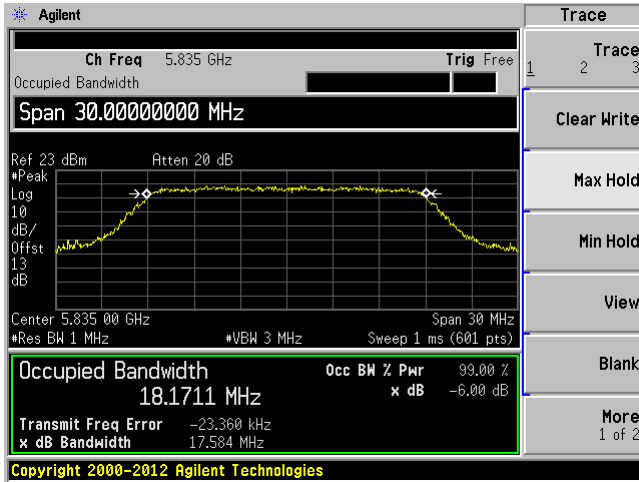

Antenna 2

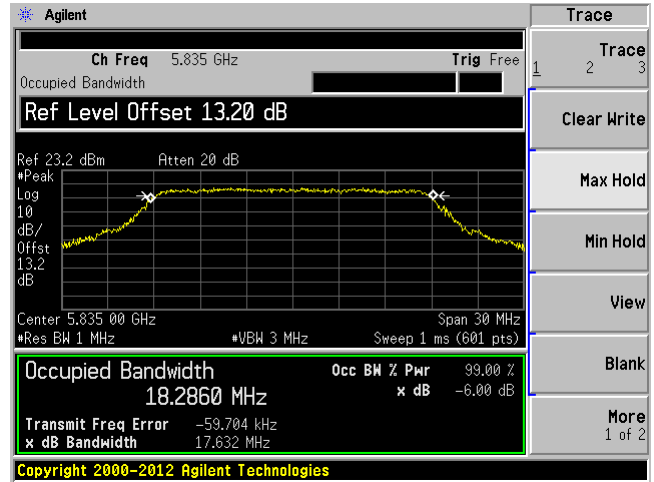

Antenna 3

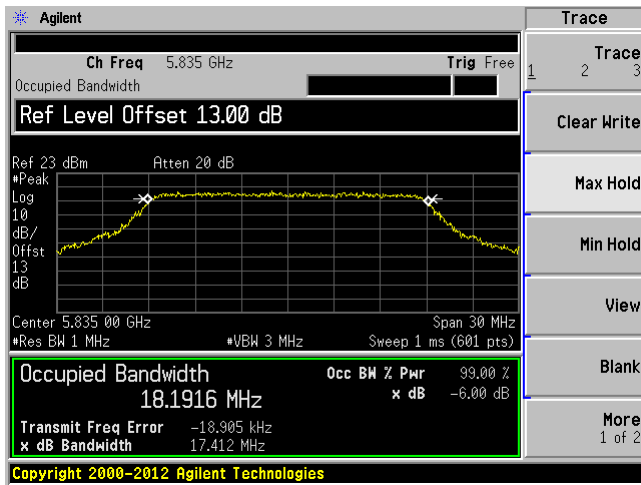

Antenna 4

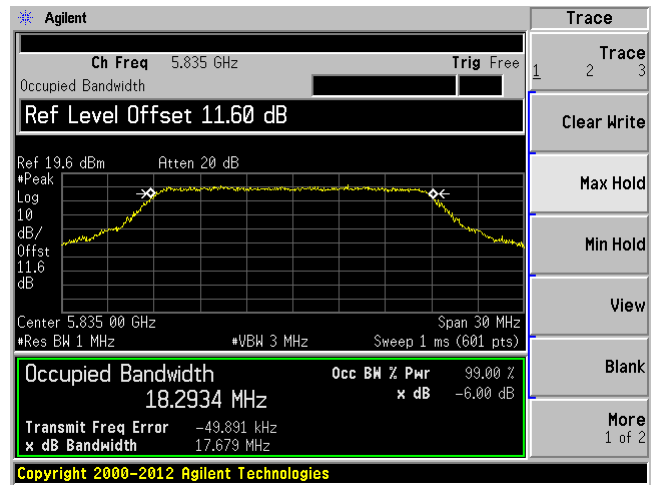

9 FCC §407(a) & IC RSS-247 §6.2.4 (1) – Maximum Conducted Output Power

9.1 Applicable Standards

According to FCC §15.407(a)

For the band 5.725-5.85 GHz, the maximum conducted output power over the frequency band of operation shall not exceed 1 W. In addition, the maximum power spectral density shall not exceed 30 dBm in any 500-kHz band. If transmitting antennas of directional gain greater than 6 dBi are used, both the maximum conducted output power and the maximum power spectral density shall be reduced by the amount in dB that the directional gain of the antenna exceeds 6 dBi. However, fixed point-to-point U-NII devices operating in this band may employ transmitting antennas with directional gain greater than 6 dBi without any corresponding reduction in transmitter conducted power. Fixed, point-to-point operations exclude the use of point-to-multipoint systems, omnidirectional applications, and multiple collocated transmitters transmitting the same information. The operator of the U-NII device, or if the equipment is professionally installed, the installer, is responsible for ensuring that systems employing high gain directional antennas are used exclusively for fixed, point-to-point operations.

As per IC RSS-247 §6.2.4 (1)

For equipment operating in the band 5725-5850 MHz, the minimum 6 dB bandwidth shall be at least 500 kHz. The maximum conducted output power shall not exceed 1 W. The power spectral density shall not exceed 30 dBm in any 500 kHz band. If transmitting antennas of directional gain greater than 6 dBi are used, both the maximum conducted output power and the power spectral density shall be reduced by the amount in dB that the directional gain of the antenna exceeds 6 dBi. However, fixed point-to-point devices operating in this band may employ transmitting antennas with directional gain greater than 6 dBi without any corresponding reduction in transmitter conducted power. Fixed point-to-point operations exclude the use of point-to-multipoint systems, omnidirectional applications and multiple collocated transmitters transmitting the same information.

9.2 Measurement Procedure

Test measurements are based on FCC KDB 789033 D02 General UNII Test Procedures New Rules v01, GUIDELINES FOR COMPLIANCE TESTING OF UNLICENSED NATIONAL INFORMATION INFRASTRUCTURE (U-NII) DEVICES PART 15, SUBPART E

9.3 Test Equipment List and Details

Manufacturer	Description	Model No.	Serial No.	Calibration Date	Calibration Interval
R & S	Signal Analyzer	FSQ	1155.5001.2 6	2015-03-09	1 year
-	SMA cable	-	C0002-6	Each time ¹	N/A
Mini-Circuits	Combiner	ZN8PD-642W-S+	SF58420133 6	Each time ¹	N/A

¹ cable and attenuator included in the test set-up will be checked each time before testing.

Statement of Traceability: *BACL Corp.* *BACL Corp.* attests that all of the calibrations on the equipment items listed above were traceable to NIST or to another internationally recognized National Metrology Institute (NMI), and were compliant with A2LA Policy P102 (dated 14 May 2015) "A2LA Policy on Metrological Traceability".

9.4 Test Environmental Conditions

Temperature:	25 °C
Relative Humidity:	45 %
ATM Pressure:	104.4 kPa

The testing was performed by Simon Ma on 2015-08-15 at RF site.

9.5 Test Results

Note1: Four antennas are correlated in case1, antenna1 and antenna3 are in same polarization; antenna2 and antenna4 are in same polarization. The directional antenna gain is $15 \text{ dBi} + 10 \cdot \log(2) = 18 \text{ dBi}$. Directional antenna gain exceeds 6 dBi by 12 dB. Thus the limit is 18 dBm.

Note2: Four antennas are fully un-correlated in case 2 and case 3. The directional antenna gain is 15 dBi, which is 9 dB exceeds 6 dBi. Thus the limit is 21 dBm.

Test mode: Case 1

Frequency (MHz)	Modulation	Power Setting				Output Power (dBm)				Total Power (mW)	Total Power (dBm)	Limit ¹ (dBm)
		Ant1	Ant2	Ant3	Ant4	Ant1	Ant2	Ant3	Ant4			
5745	BPSK	15	15	15	19	11.63	10.04	11.43	11.09	51.40	17.11	18
	QPSK	15	15	15	19	11.70	10.13	11.55	11.15	52.42	17.19	18
	16QAM	15	15	15	19	12.14	10.42	11.86	11.47	56.76	17.54	18
	64QAM	15	15	15	19	12.03	10.58	12.01	11.59	57.69	17.61	18
5785	BPSK	15	15	15	21	12.29	10.24	11.59	11.38	55.67	17.46	18
	QPSK	15	15	15	21	12.30	10.39	11.69	11.54	56.94	17.55	18
	16QAM	15	15	15	21	12.55	10.83	12.00	11.82	61.15	17.86	18
	64QAM	15	15	15	21	12.65	10.90	12.03	11.95	62.34	17.95	18
5835	BPSK	15	17	19	21	11.47	11.08	11.37	9.94	50.42	17.03	18
	QPSK	15	17	19	21	11.60	11.21	11.51	10.05	51.94	17.16	18
	16QAM	15	17	19	21	11.95	11.52	11.73	10.37	55.64	17.45	18
	64QAM	15	17	19	21	12.14	11.71	11.87	10.49	57.77	17.62	18

Test mode: Case 2

Frequency (MHz)	Modulation	Power Setting		Output Power (dBm)		Total Power (mW)	Total Power (dBm)	Limit ² (dBm)
		Antenna 1 & 3	Antenna 2 & 4	Antenna 1 & 3	Antenna 2 & 4			
5755	BPSK	21	23	17.90	16.78	109.30	20.39	21
	QPSK	21	23	17.97	16.82	110.75	20.44	21
	16QAM	21	23	18.25	17.10	118.12	20.72	21
	64QAM	21	23	18.36	17.25	121.64	20.85	21
5785	BPSK	21	23	17.05	17.05	101.40	20.06	21
	QPSK	21	23	17.09	17.16	103.17	20.14	21
	16QAM	21	23	17.42	17.46	110.93	20.45	21
	64QAM	21	23	17.85	17.67	119.43	20.77	21
5825	BPSK	21	23	17.04	16.76	98.01	19.91	21
	QPSK	21	23	17.07	16.79	98.69	19.94	21
	16QAM	21	23	17.42	17.06	106.02	20.25	21
	64QAM	21	23	17.50	17.36	110.68	20.44	21

Test mode: Case 3

Frequency (MHz)	Antenna	Power Setting	Output Power (dBm)				Limit ² (dBm)
			BPSK	QPSK	16QAM	64QAM	
5745	1	25	16.50	16.58	16.85	17.05	21
	2	27	16.37	16.53	16.83	16.95	21
	3	25	15.95	16.09	16.36	16.49	21
	4	29	14.47	14.56	14.91	15.02	21
5785	1	30	19.13	19.32	19.62	19.74	21
	2	32	19.76	19.84	20.23	20.36	21
	3	32	19.79	19.87	20.17	20.31	21
	4	38	19.57	18.75	19.88	19.98	21
5835	1	21	14.20	14.29	14.62	15.06	21
	2	23	13.82	13.89	14.22	14.38	21
	3	23	13.27	13.38	13.69	13.87	21
	4	27	12.86	12.94	13.23	13.32	21

Please refer to the following plots.

Conducted Output Power

Case 1-BPSK

Low Channel: 5745 MHz

Antenna 1

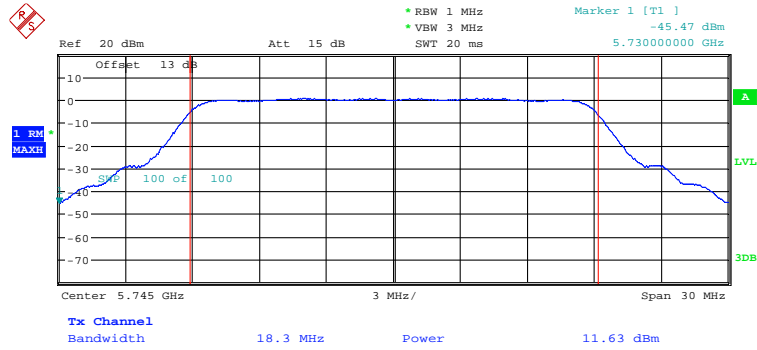

Date: 7.AUG.2015 14:07:05

Antenna 2

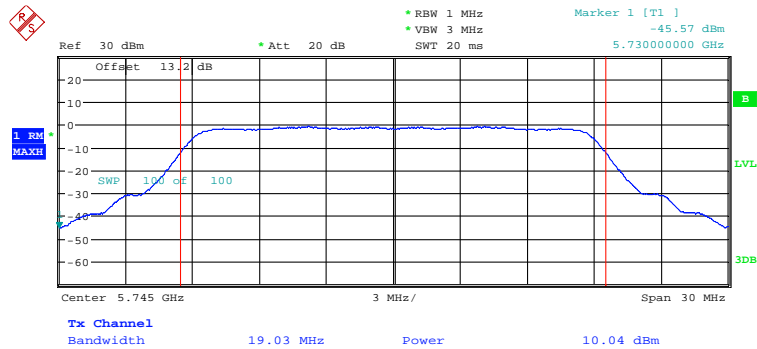

Date: 14.AUG.2015 23:20:17

Antenna 3

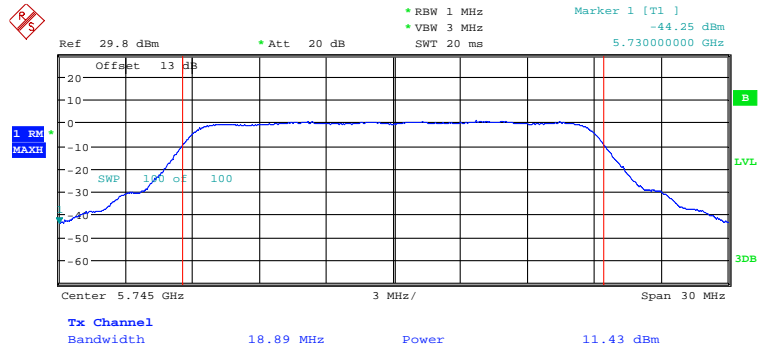

Date: 14.AUG.2015 23:34:00

Antenna 4

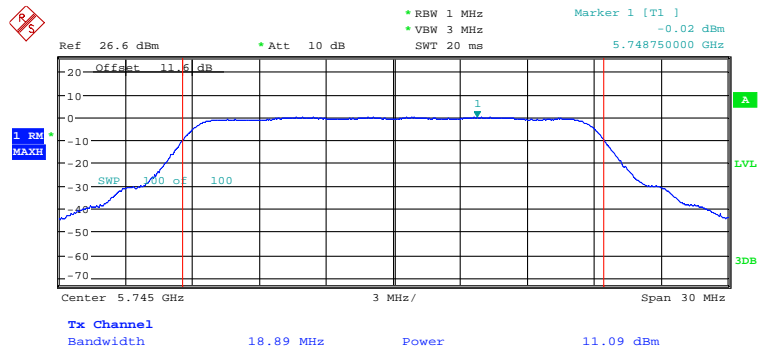

Date: 19.AUG.2015 16:26:44

Middle Channel: 5785 MHz

Antenna 1

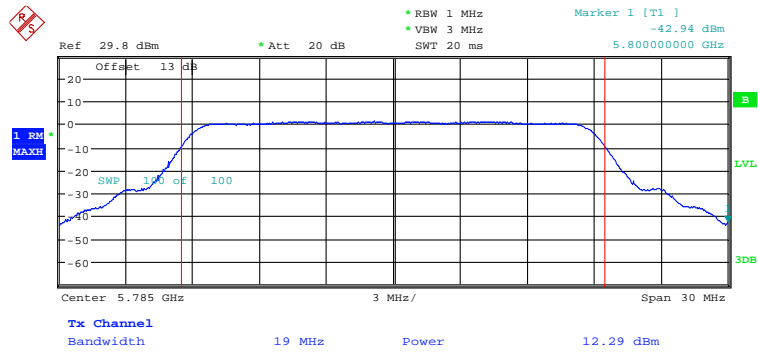

Date: 15.AUG.2015 15:26:02

Antenna 2

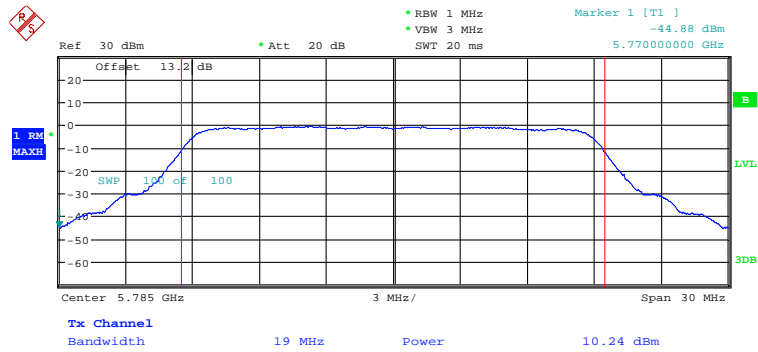

Date: 15.AUG.2015 13:58:14

Antenna 3

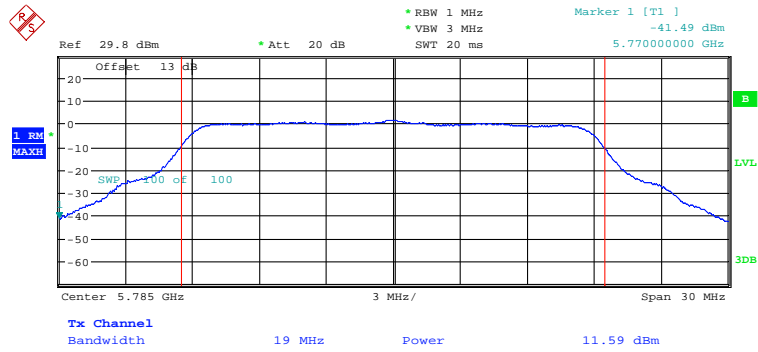

Date: 15.AUG.2015 14:01:21

Antenna 4

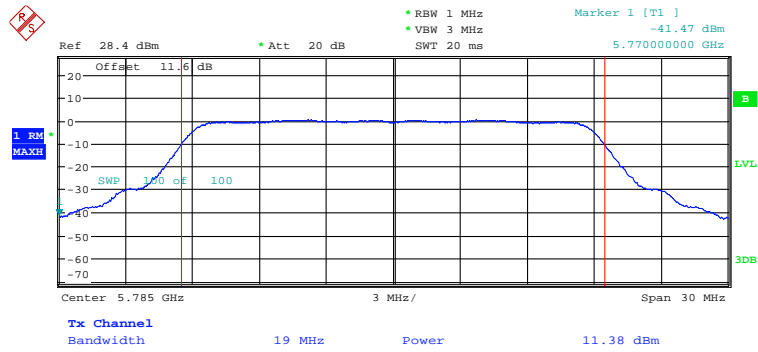

Date: 15.AUG.2015 14:03:33

High Channel: 5835 MHz

Antenna 1

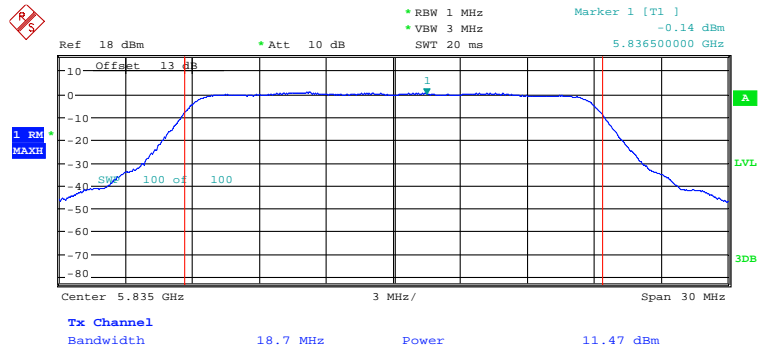

Date: 27.SEP.2015 18:18:05

Antenna 2

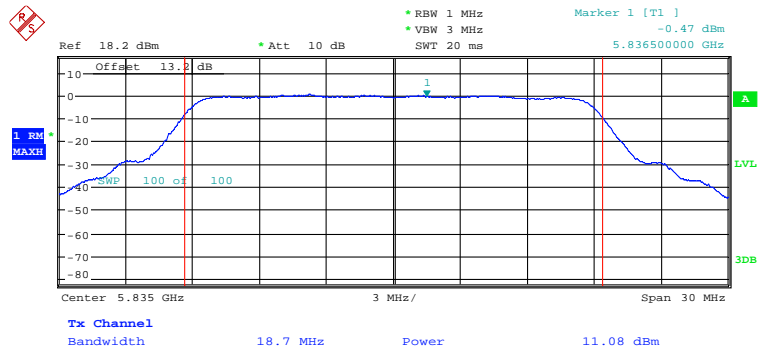

Date: 27.SEP.2015 18:33:12

Antenna 3

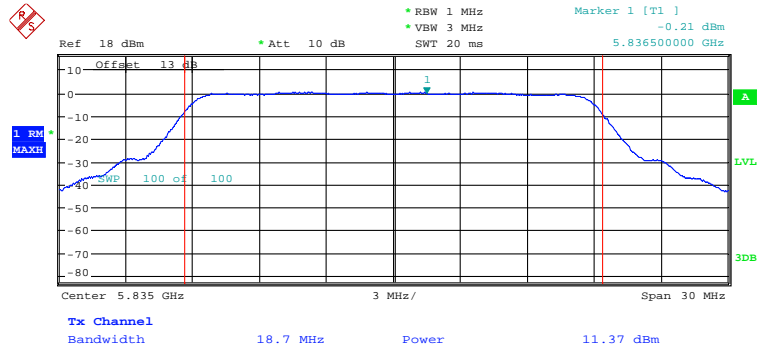

Date: 27.SEP.2015 18:33:51

Antenna 4

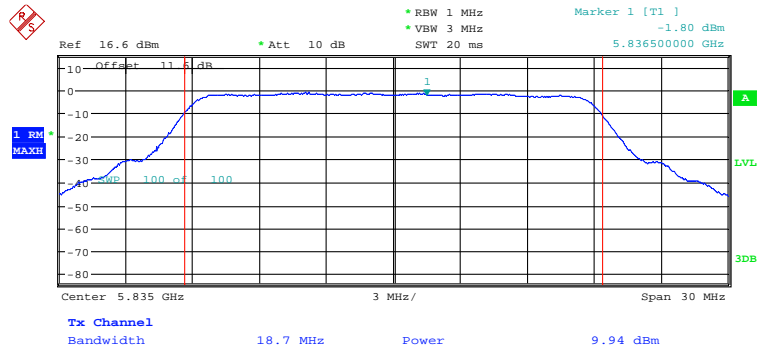

Date: 27.SEP.2015 18:26:58

Case 1-QPSK

Low Channel: 5745 MHz

Antenna 1

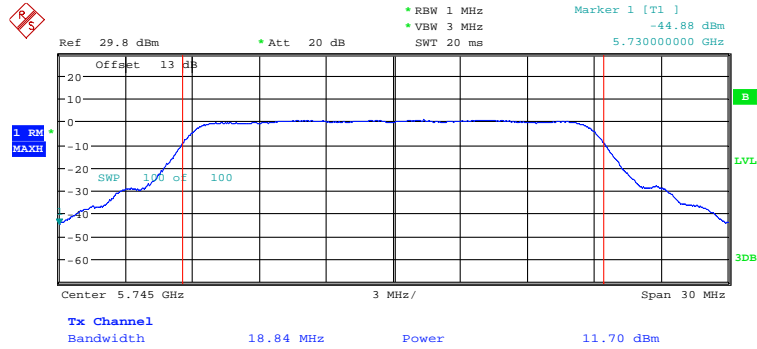

Date: 14.AUG.2015 23:06:17

Antenna 2

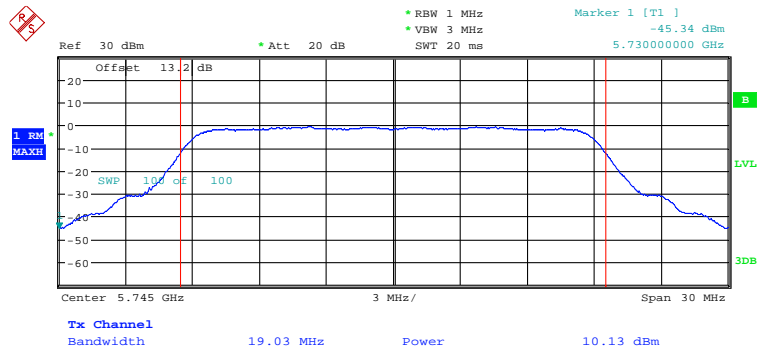

Date: 14.AUG.2015 23:21:12

Antenna 3

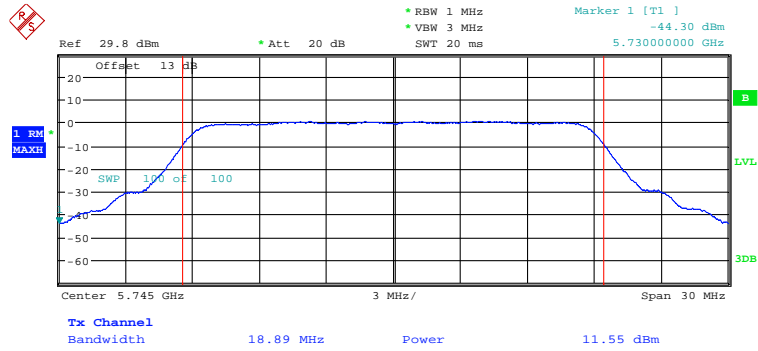

Date: 14.AUG.2015 23:34:33

Antenna 4

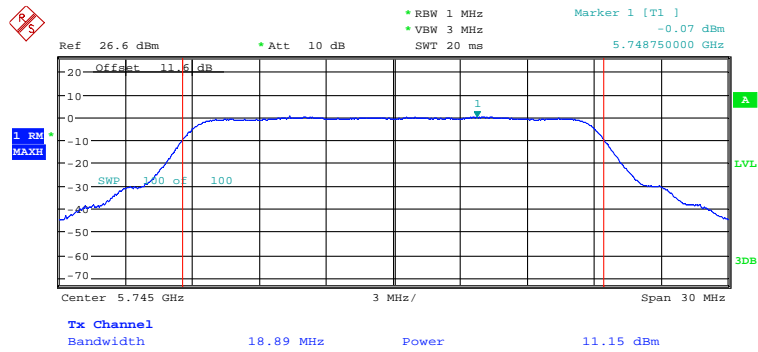

Date: 19.AUG.2015 16:27:26

Middle Channel: 5785 MHz

Antenna 1

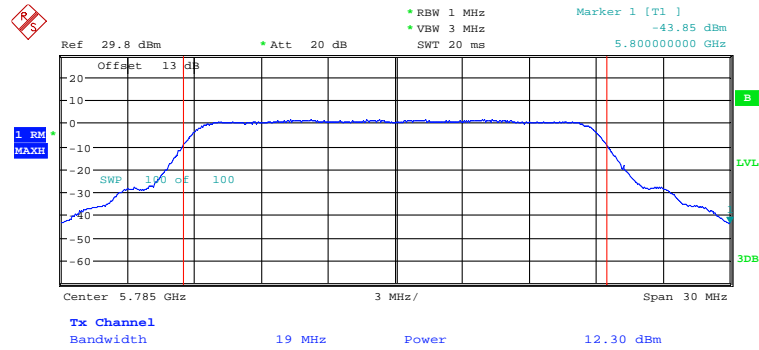

Date: 15.AUG.2015 15:23:32

Antenna 2

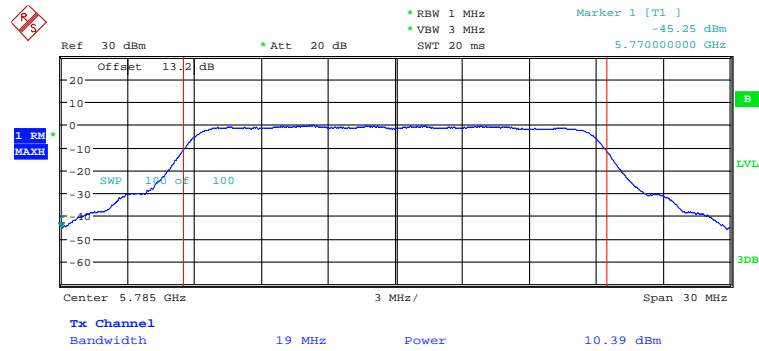

Date: 15.AUG.2015 13:58:51

Antenna 3

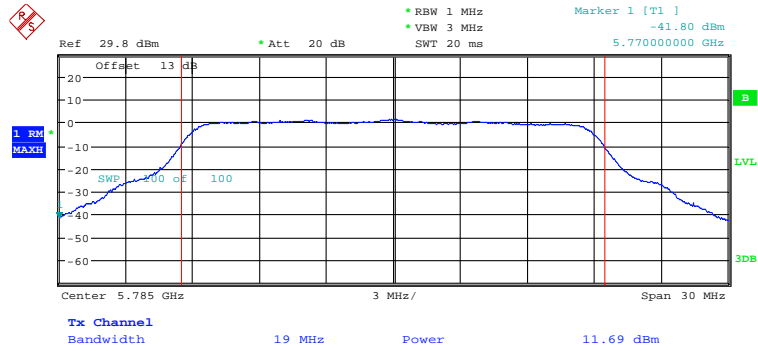

Date: 15.AUG.2015 14:01:50

Antenna 4

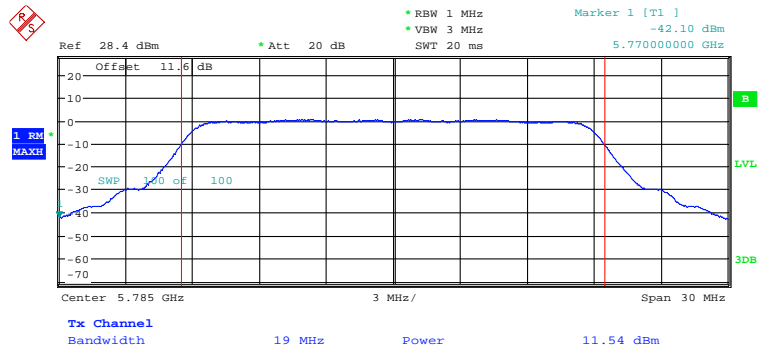

Date: 15.AUG.2015 14:04:02

High Channel: 5835 MHz

Antenna 1

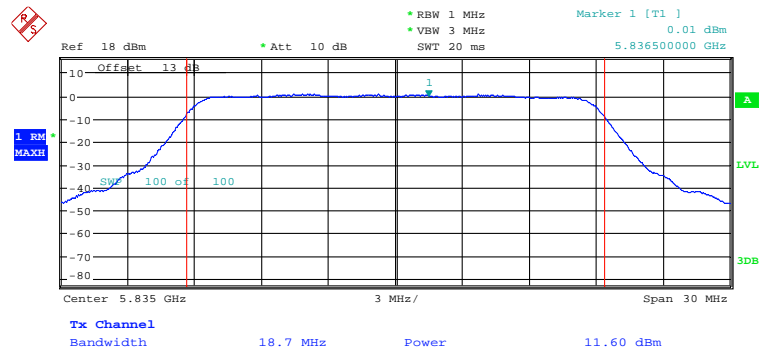

Date: 27.SEP.2015 18:17:30

Antenna 2

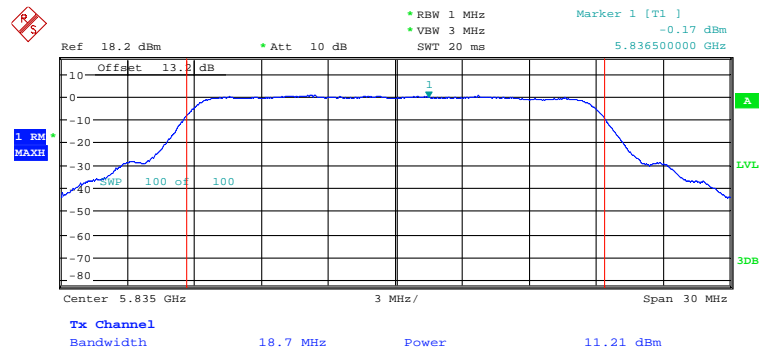

Date: 27.SEP.2015 18:32:39

Antenna 3

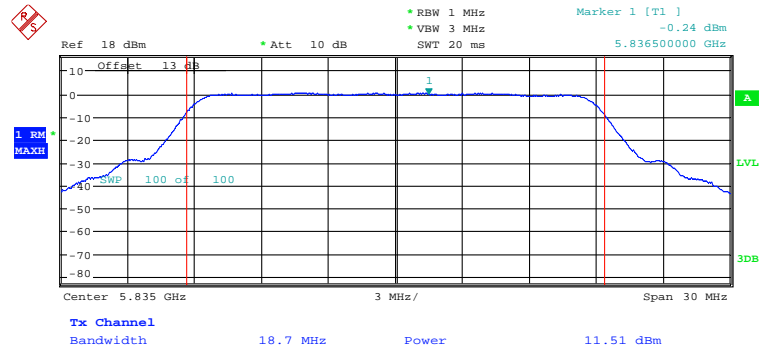

Date: 27.SEP.2015 18:34:28

Antenna 4

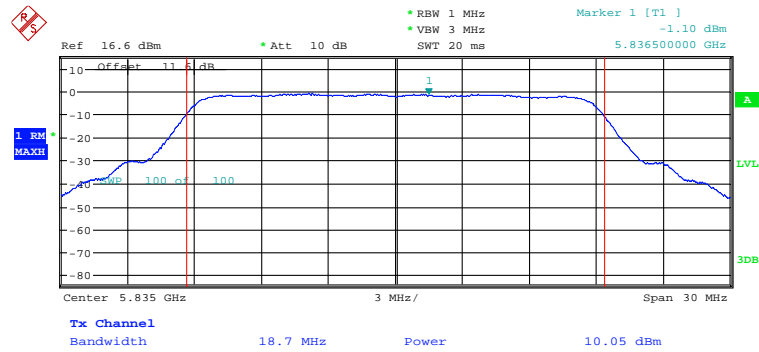

Date: 27.SEP.2015 18:26:25

Case 1-16QAM

Low Channel: 5745 MHz

Antenna 1

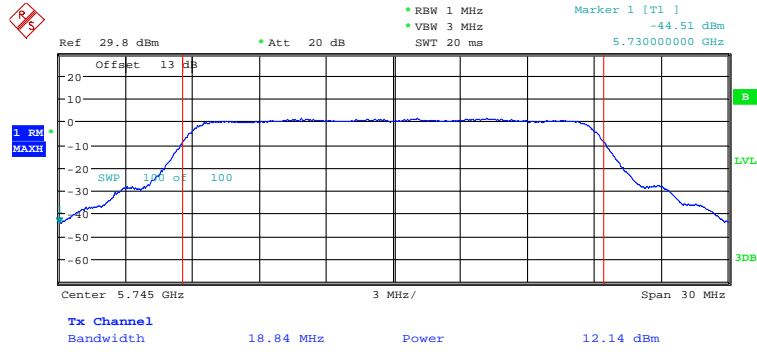

Date: 14.AUG.2015 23:13:01

Antenna 2

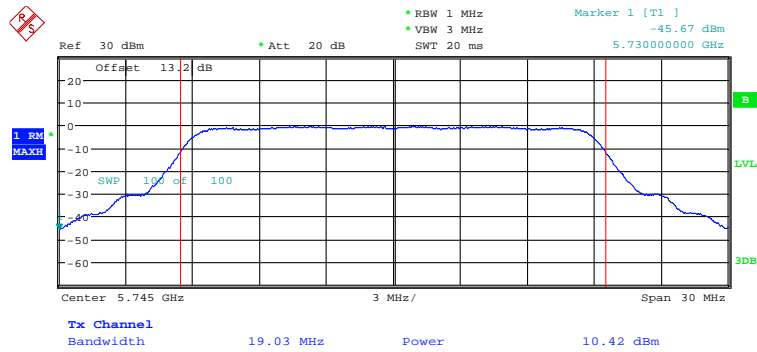

Date: 14.AUG.2015 23:21:52

Antenna 3

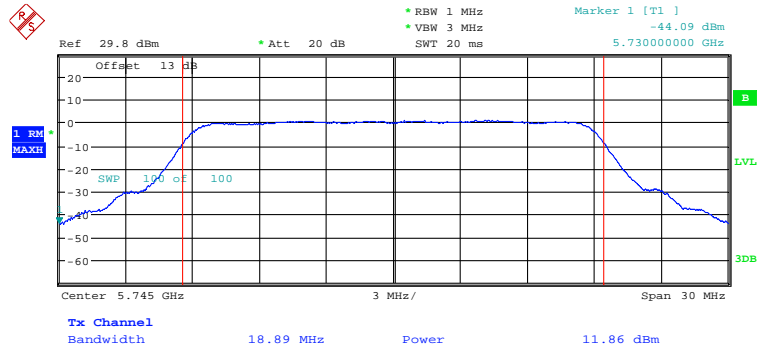

Date: 14.AUG.2015 23:35:07

Antenna 4

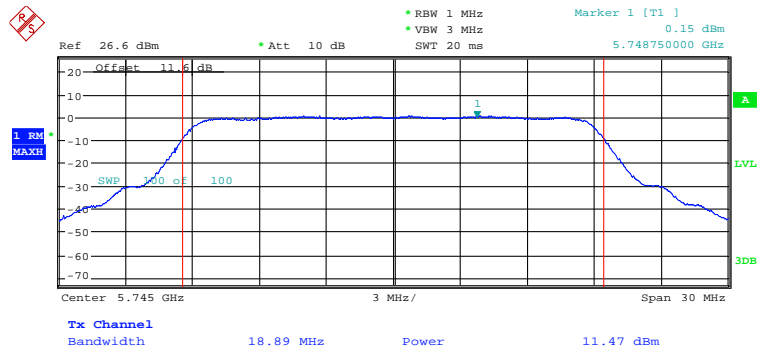

Date: 19.AUG.2015 16:28:05

Middle Channel: 5785 MHz

Antenna 1

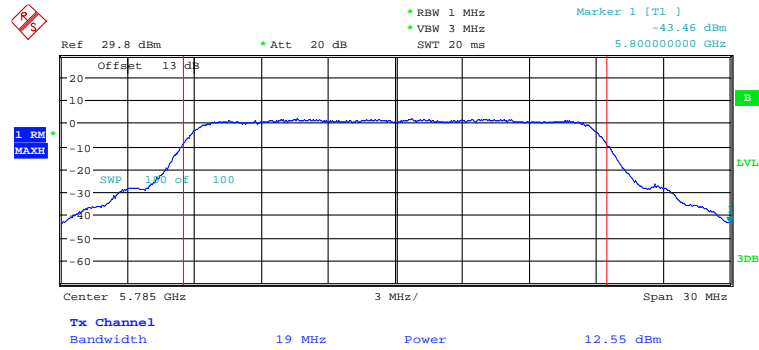

Date: 15.AUG.2015 15:22:54

Antenna 2

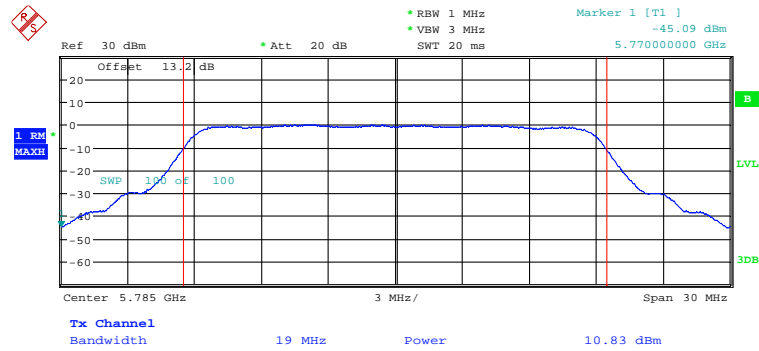

Date: 15.AUG.2015 13:59:51

Antenna 3

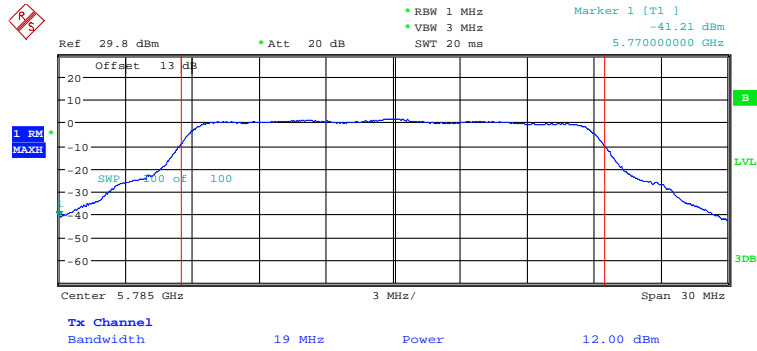

Date: 15.AUG.2015 14:02:17

Antenna 4

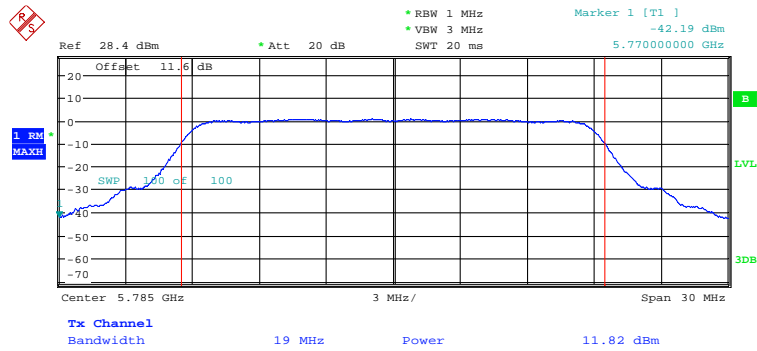

Date: 15.AUG.2015 14:04:31

High Channel: 5835 MHz

Antenna 1

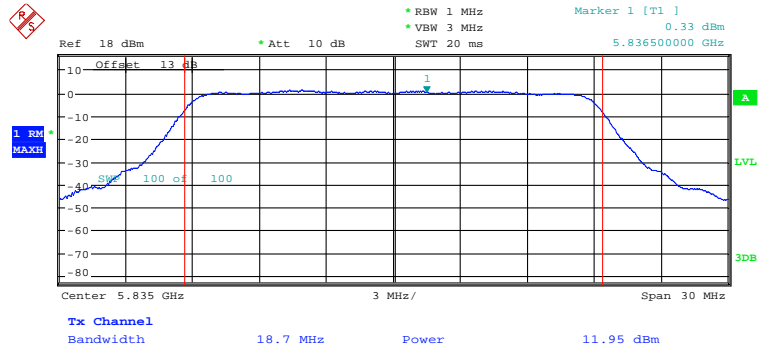

Date: 27.SEP.2015 18:16:45

Antenna 2

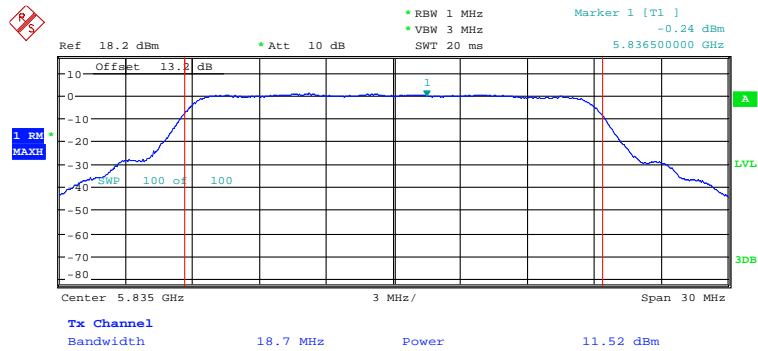

Date: 27.SEP.2015 18:32:06

Antenna 3

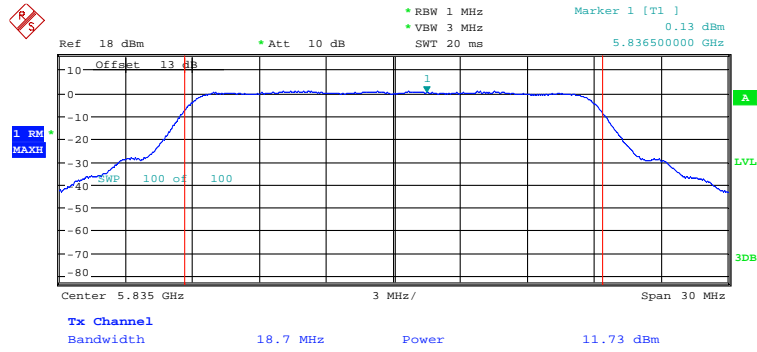

Date: 27.SEP.2015 18:35:09

Antenna 4

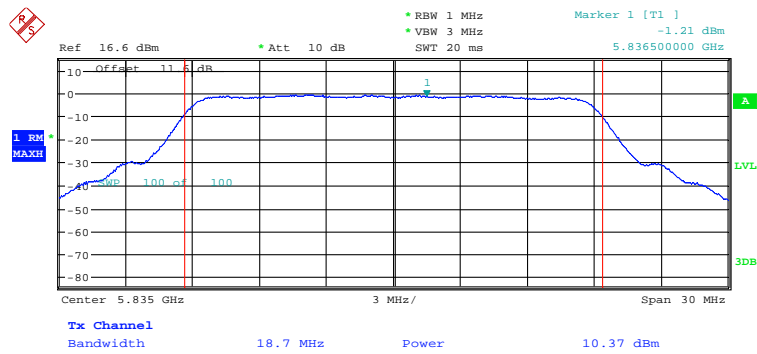

Date: 27.SEP.2015 18:25:52

Case 1-64QAM

Low Channel: 5745 MHz

Antenna 1

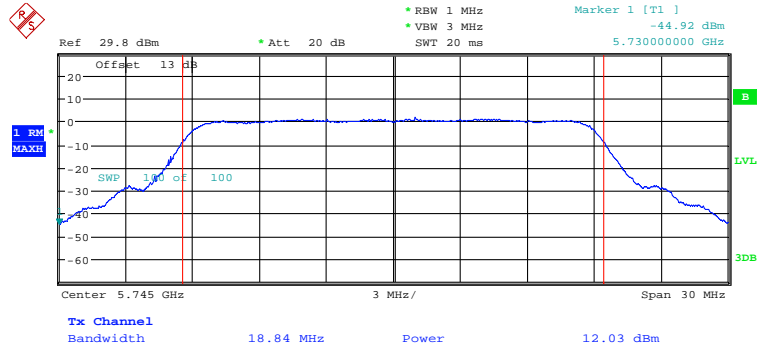

Date: 14.AUG.2015 23:16:45

Antenna 2

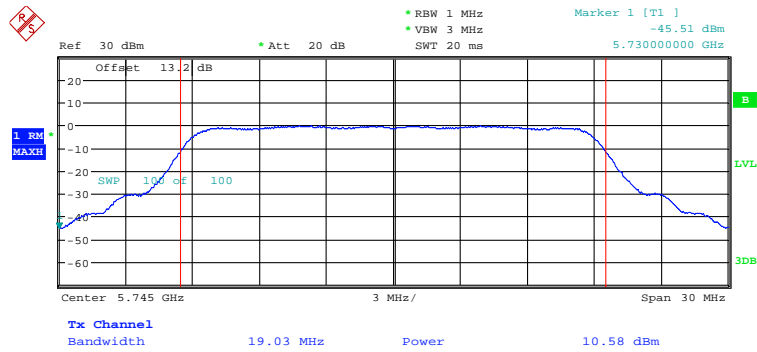

Date: 14.AUG.2015 23:22:33

Antenna 3

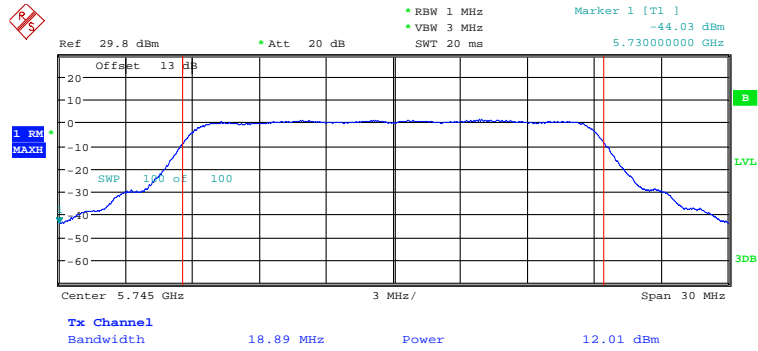

Date: 14.AUG.2015 23:35:44

Antenna 4

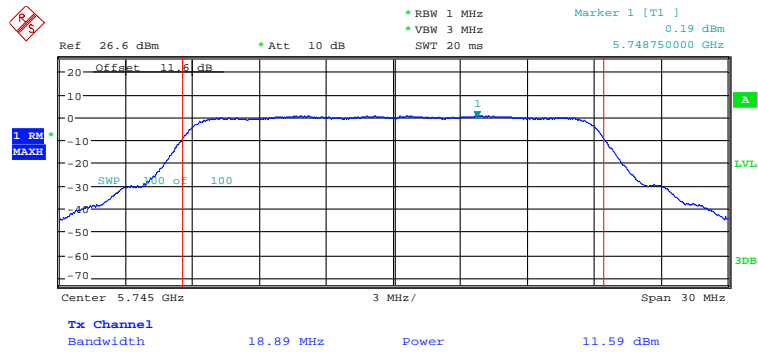

Date: 19.AUG.2015 16:28:38

Middle Channel: 5785 MHz

Antenna 1

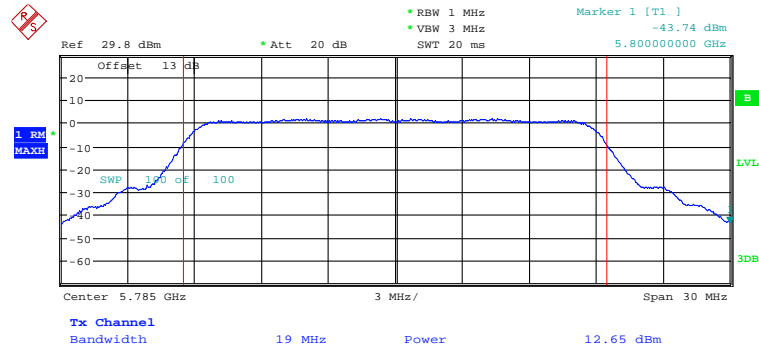

Date: 15.AUG.2015 15:20:33

Antenna 2

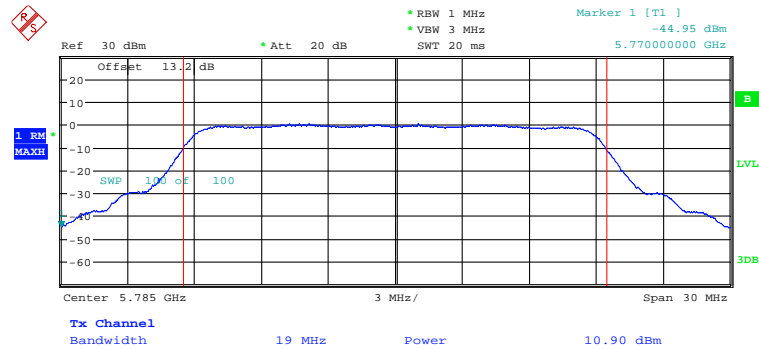

Date: 15.AUG.2015 14:00:42

Antenna 3

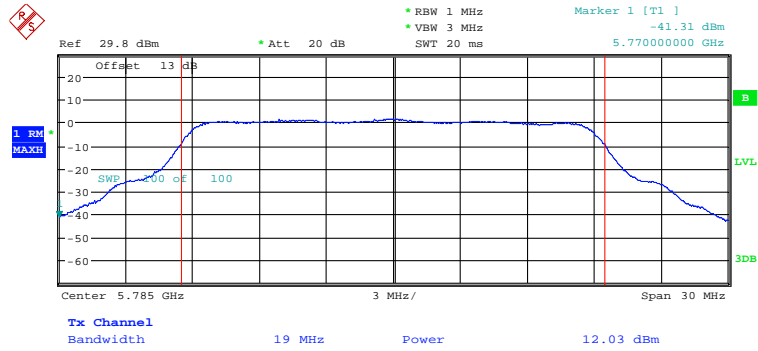

Date: 15.AUG.2015 14:02:54

Antenna 4

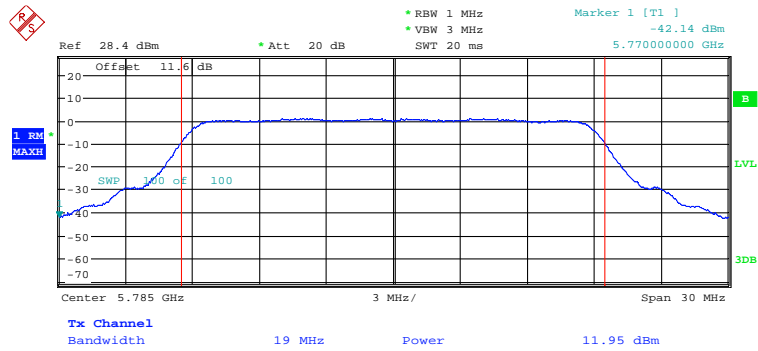

Date: 15.AUG.2015 14:05:00

High Channel: 5835 MHz

Antenna 1

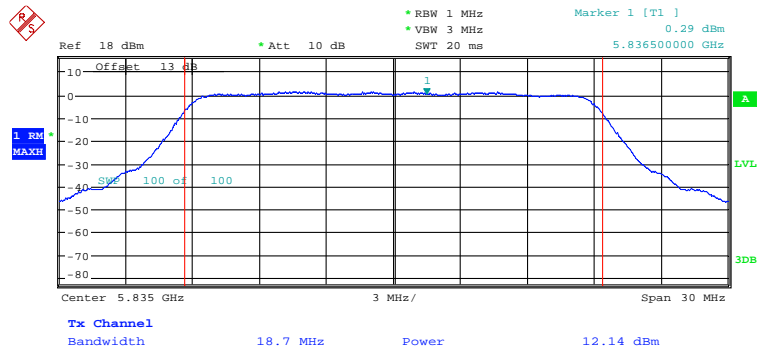

Date: 27.SEP.2015 18:15:19

Antenna 2

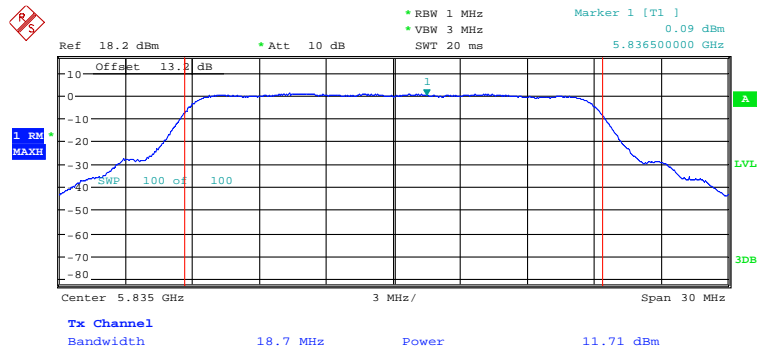

Date: 27.SEP.2015 18:31:18

Antenna 3

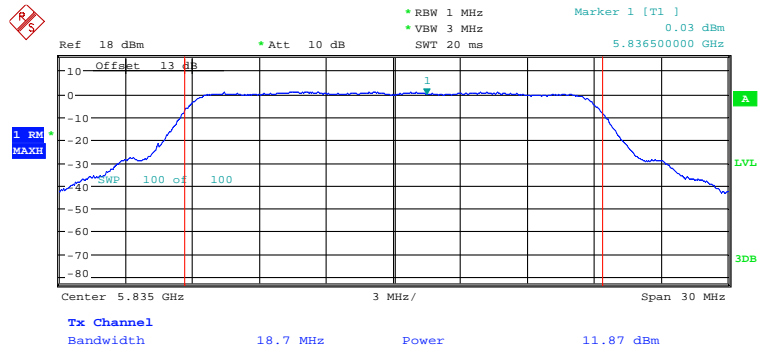

Date: 27.SEP.2015 18:35:43

Antenna 4

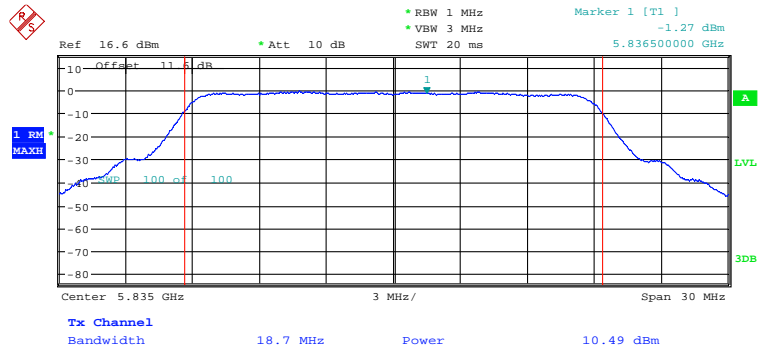

Date: 27.SEP.2015 18:25:03

Case 2-BPSK

Low Channel 5755 MHz

Antenna 1 & 3

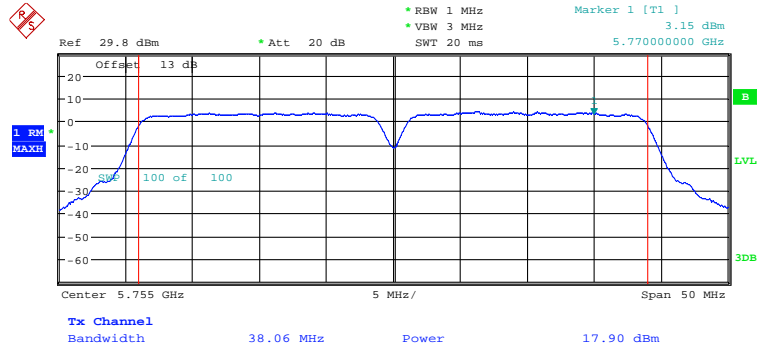

Date: 15.AUG.2015 17:43:37

Antenna 2 & 4

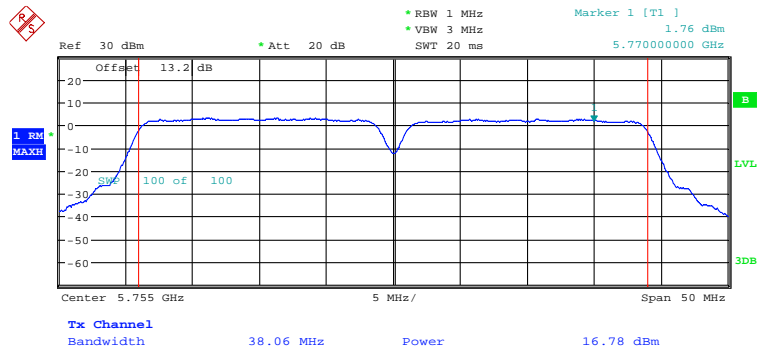

Date: 15.AUG.2015 17:45:30

Middle Channel 5785 MHz

Antenna 1 & 3

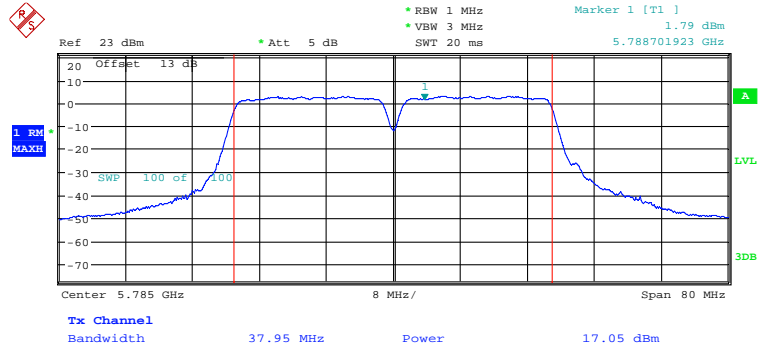

Date: 27.SEP.2015 12:49:47

Antenna 2 & 4

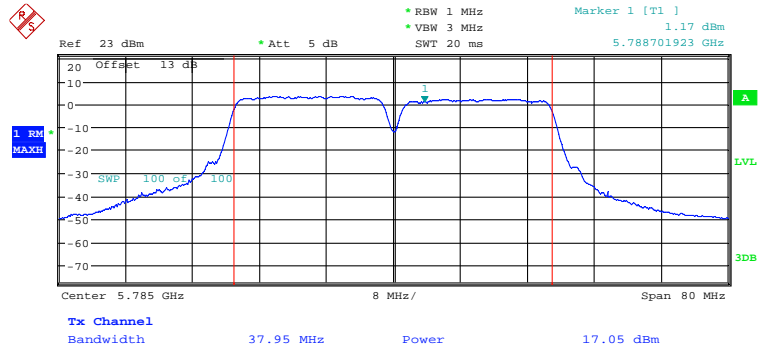

Date: 27.SEP.2015 12:52:21

High Channel 5825 MHz

Antenna 1 & 3

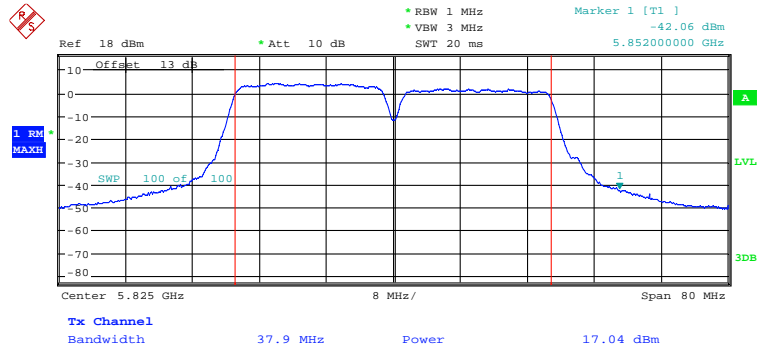

Date: 27.SEP.2015 17:43:05

Antenna 2 & 4

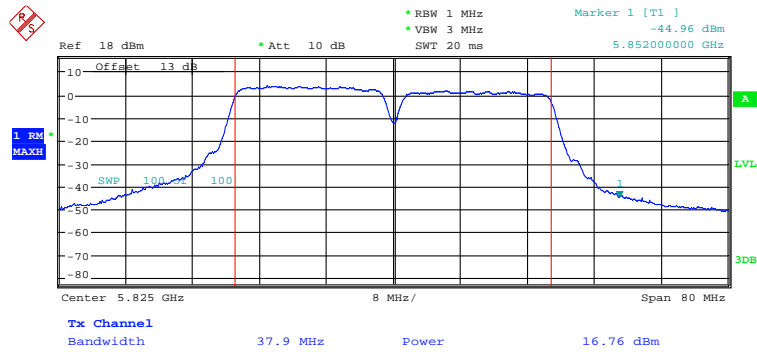

Date: 27.SEP.2015 17:38:22

Case 2-QPSK

Low Channel 5755 MHz

Antenna 1 & 3

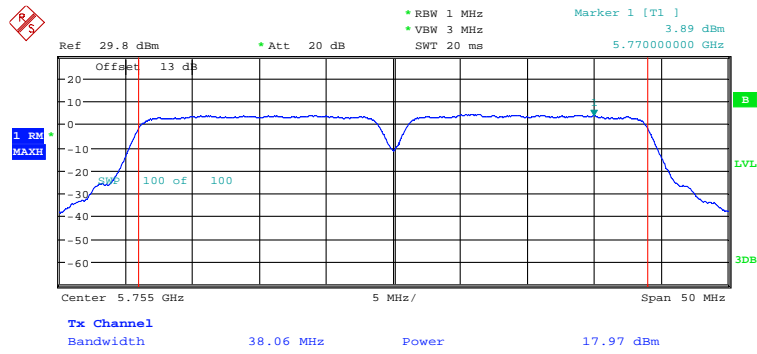

Date: 15.AUG.2015 17:44:06

Antenna 2 & 4

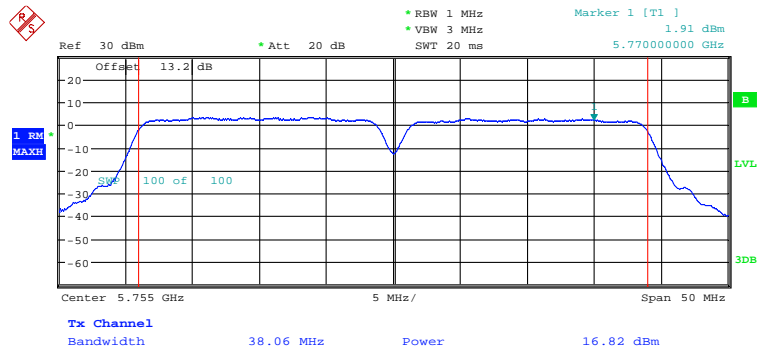

Date: 15.AUG.2015 17:45:58

Middle Channel 5785 MHz

Antenna 1 & 3

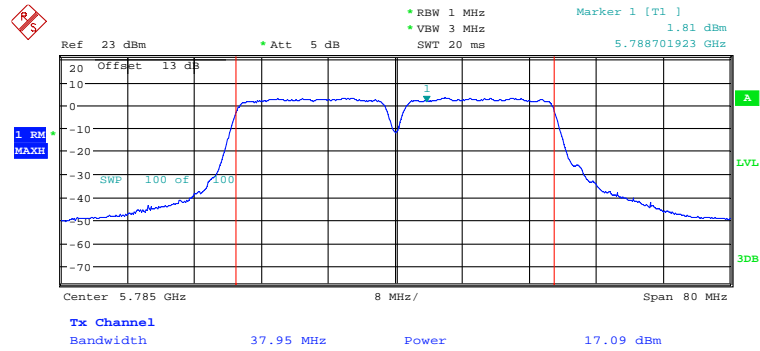

Date: 27.SEP.2015 12:48:52

Antenna 2 & 4

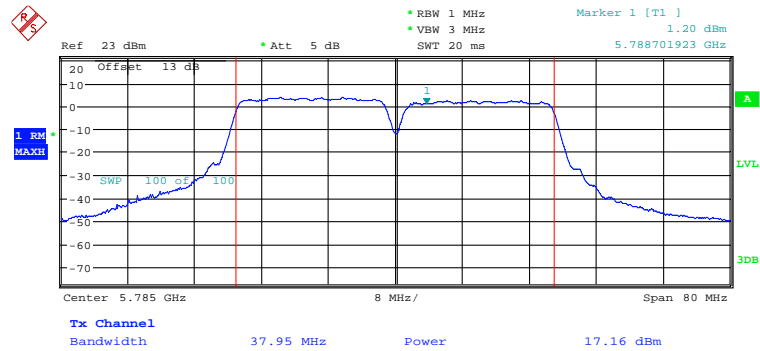

Date: 27.SEP.2015 12:53:06

High Channel 5825 MHz

Antenna 1 & 3

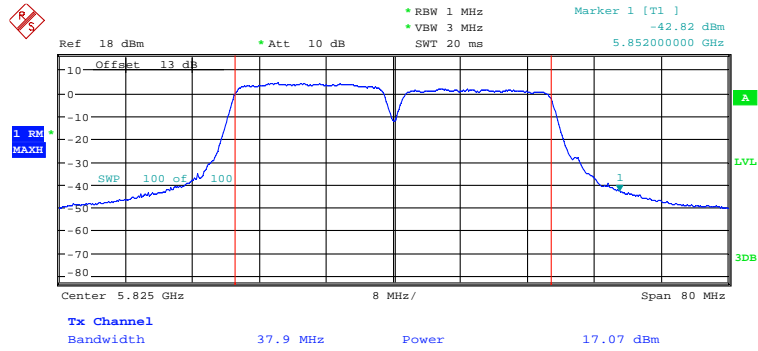

Date: 27.SEP.2015 17:42:30

Antenna 2 & 4

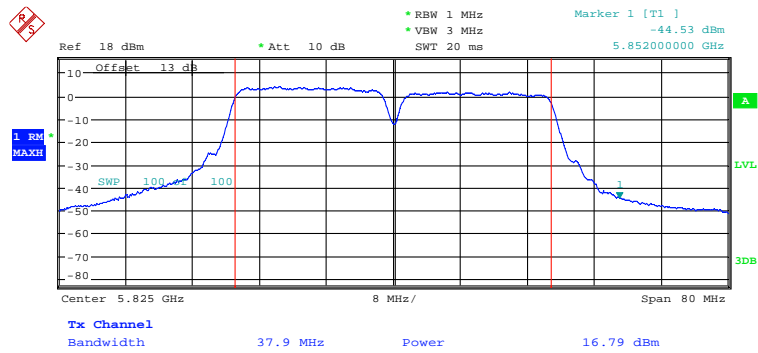

Date: 27.SEP.2015 17:39:04

Case 2-16QAM

Low Channel 5755 MHz

Antenna 1 & 3

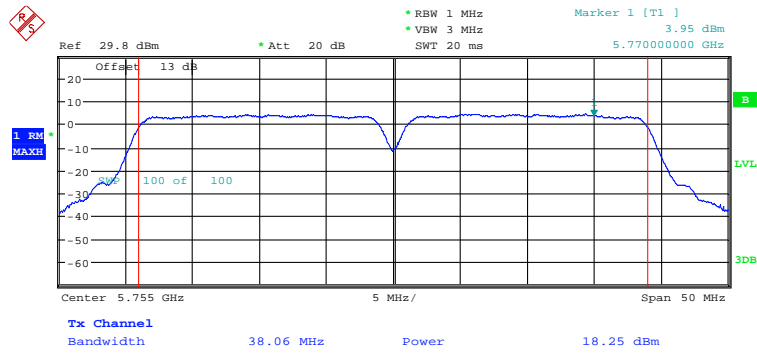

Date: 15.AUG.2015 17:44:33

Antenna 2 & 4

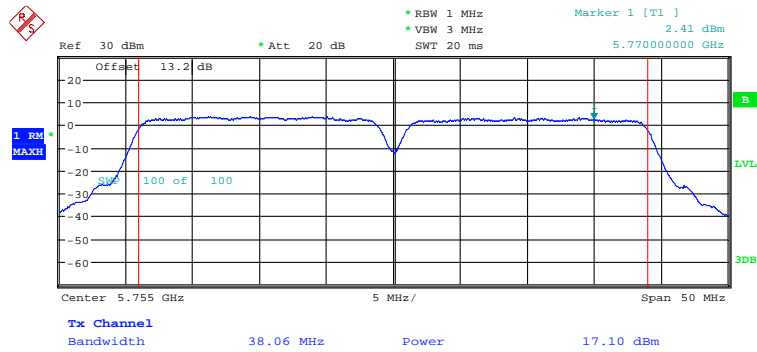

Date: 15.AUG.2015 17:46:29

Middle Channel 5785 MHz

Antenna 1 & 3

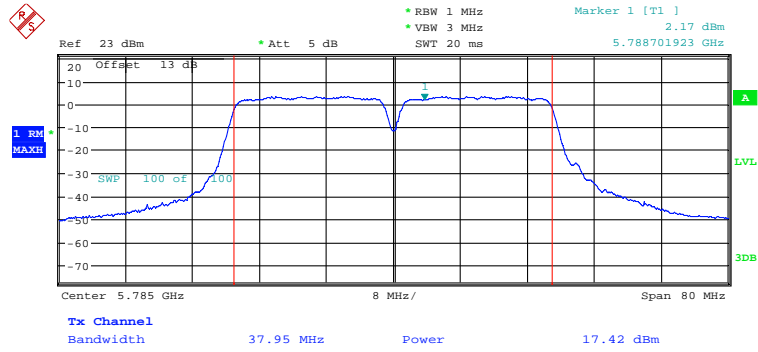

Date: 27.SEP.2015 12:47:57

Antenna 2 & 4

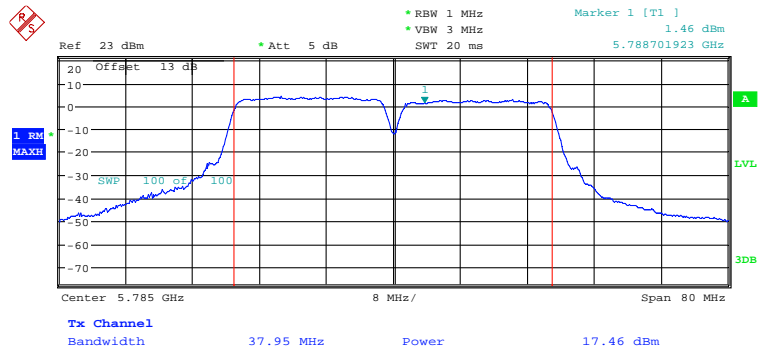

Date: 27.SEP.2015 12:53:56

High Channel 5825 MHz

Antenna 1 & 3

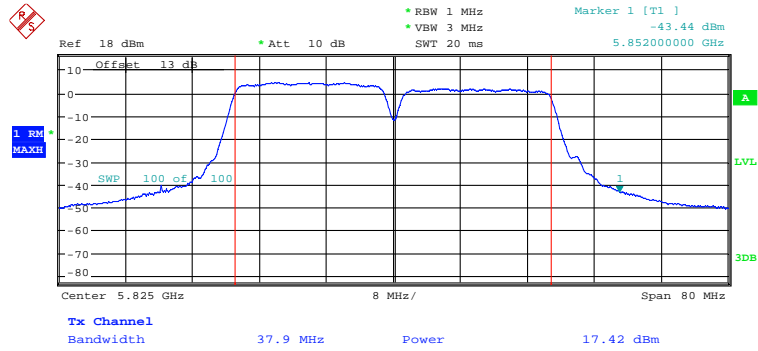

Date: 27.SEP.2015 17:41:22

Antenna 2 & 4

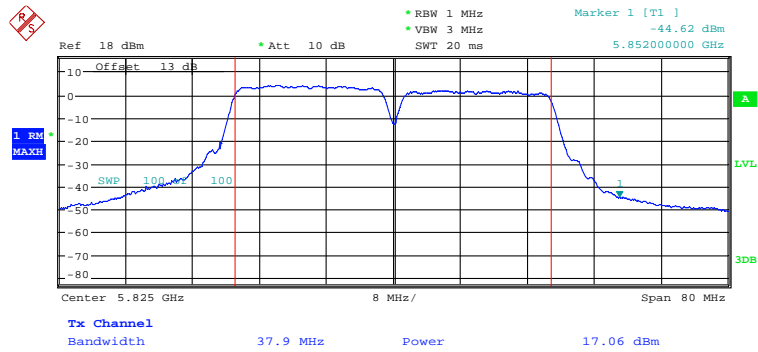

Date: 27.SEP.2015 17:39:39

Case 2-64QAM

Low Channel 5755 MHz

Antenna 1 & 3

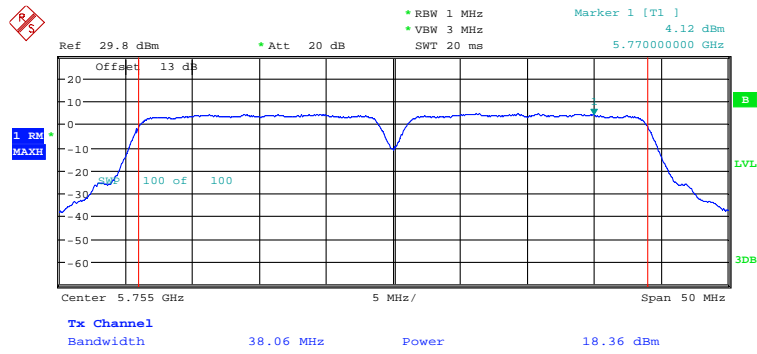

Date: 15.AUG.2015 17:45:03

Antenna 2 & 4

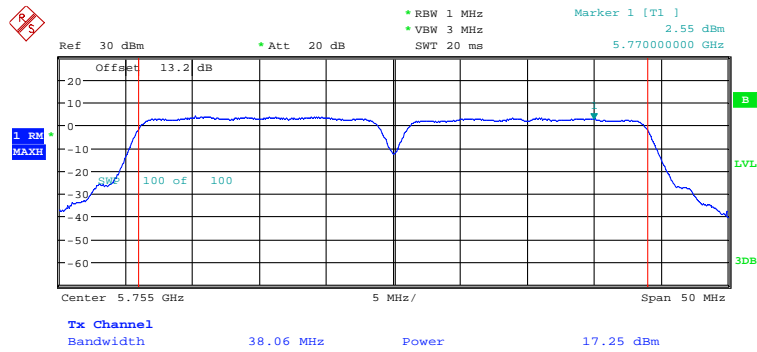

Date: 15.AUG.2015 17:46:56

Middle Channel 5785 MHz

Antenna 1 & 3

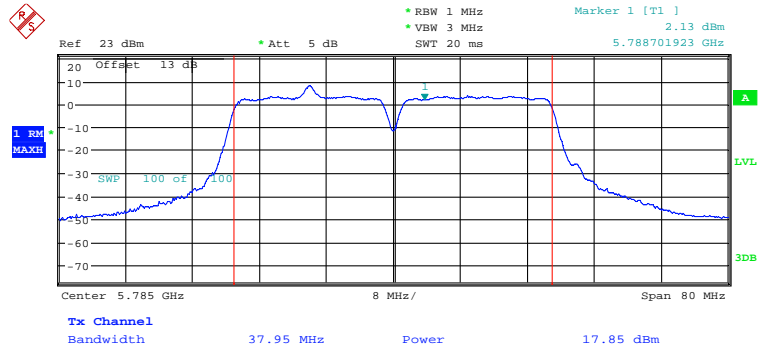

Date: 27.SEP.2015 12:44:44

Antenna 2 & 4

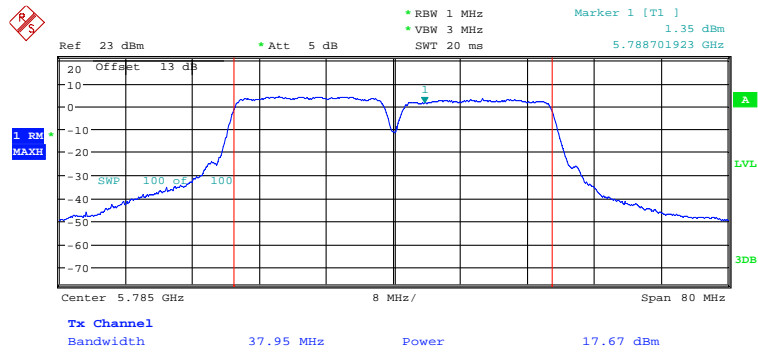

Date: 27.SEP.2015 12:54:56

High Channel 5825 MHz

Antenna 1 & 3

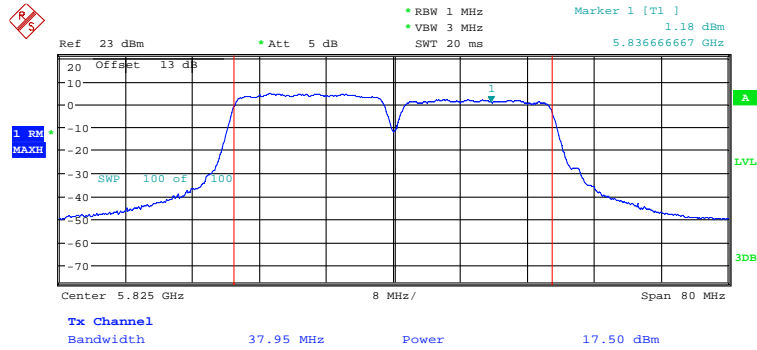

Date: 25.SEP.2015 22:40:34

Antenna 2 & 4

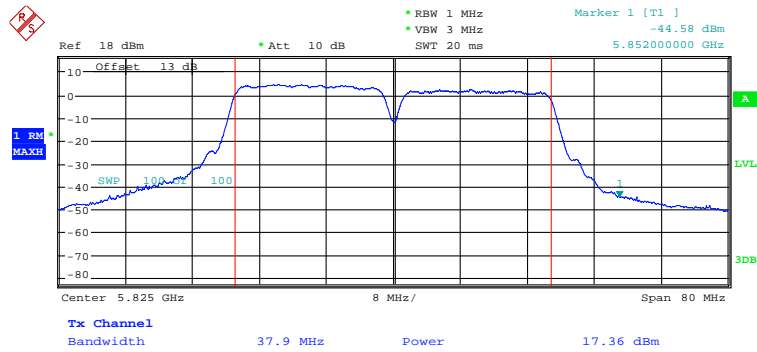

Date: 27.SEP.2015 17:40:10

Case 3-BPSK

Low Channel: 5745 MHz

Antenna 1

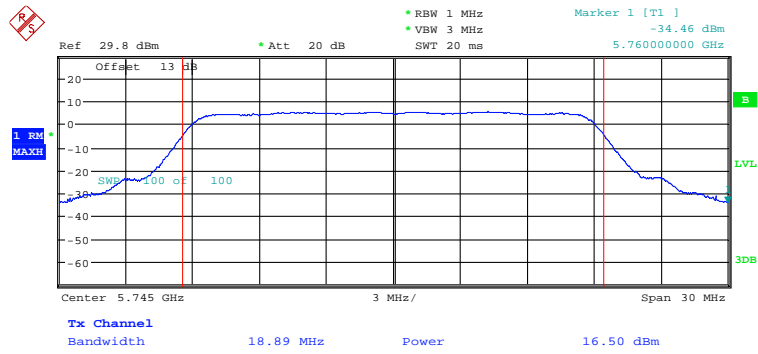

Date: 15.AUG.2015 15:49:17

Antenna 2

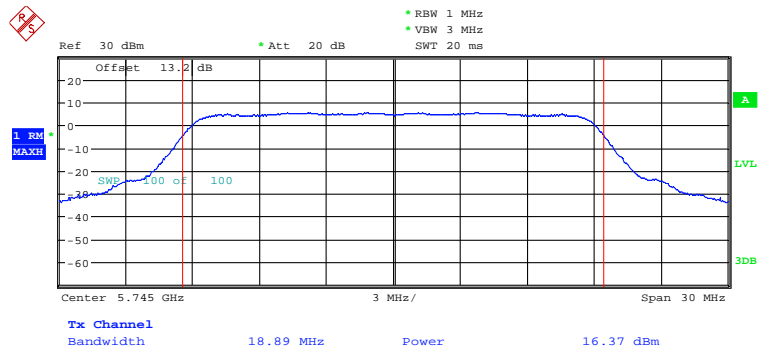

Date: 17.AUG.2015 23:09:11

Antenna 3

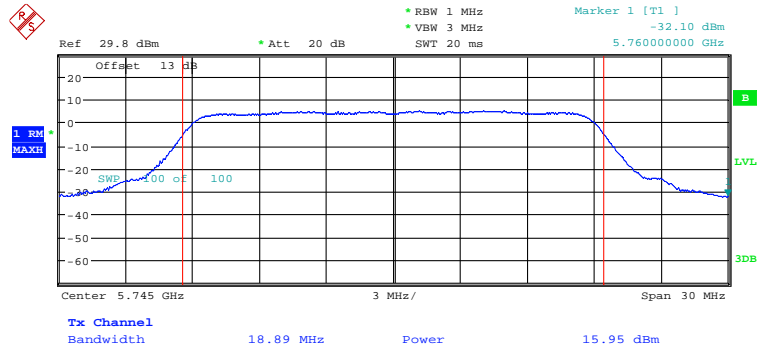

Date: 15.AUG.2015 15:57:55

Antenna 4

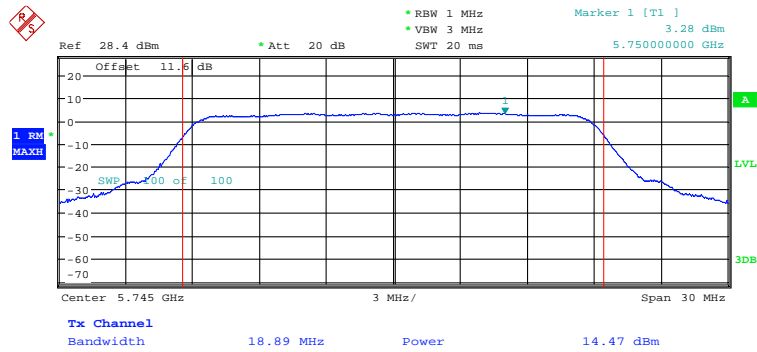

Date: 17.AUG.2015 23:28:07

Middle Channel: 5785 MHz

Antenna 1

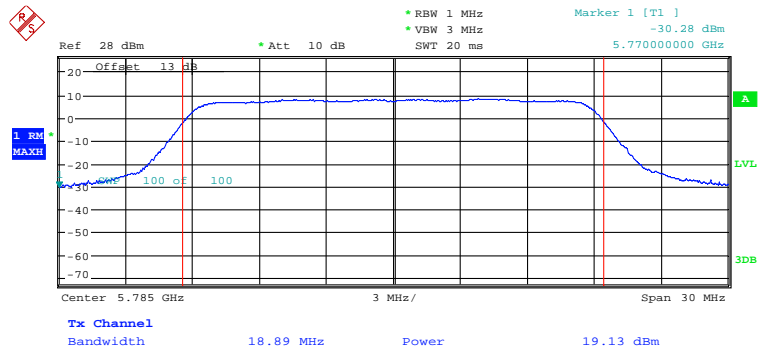

Date: 25.SEP.2015 22:53:22

Antenna 2

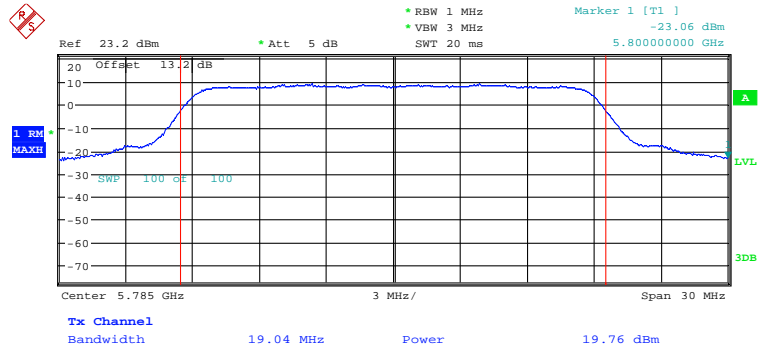

Date: 25.SEP.2015 23:03:04

Antenna 3

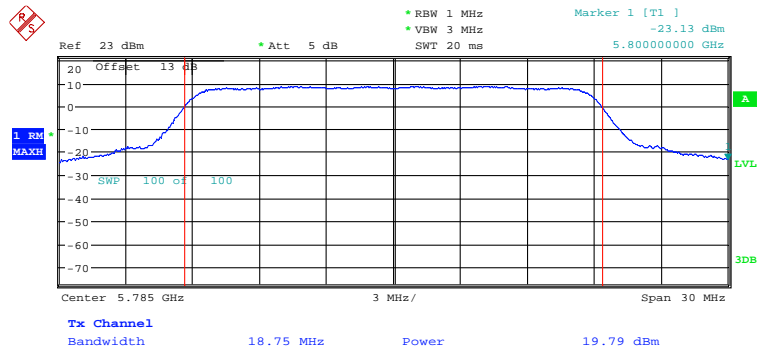

Date: 25.SEP.2015 23:18:29

Antenna 4

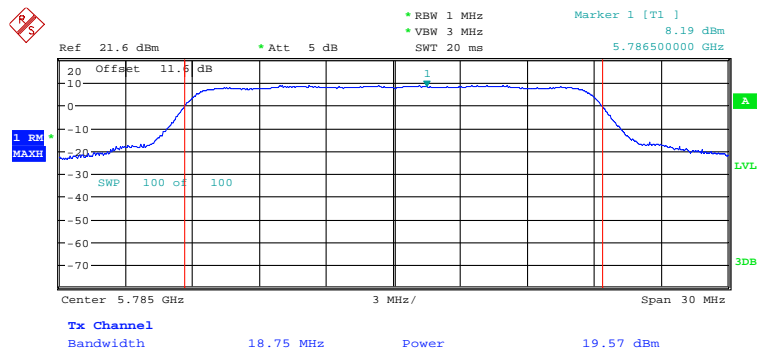

Date: 25.SEP.2015 23:28:39

High Channel: 5835 MHz

Antenna 1

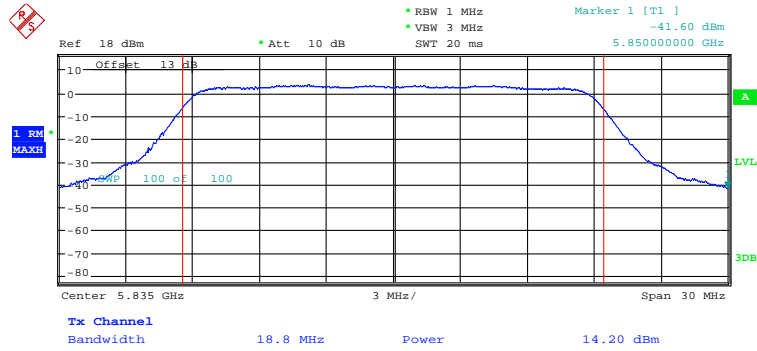

Date: 27.SEP.2015 13:52:10

Antenna 2

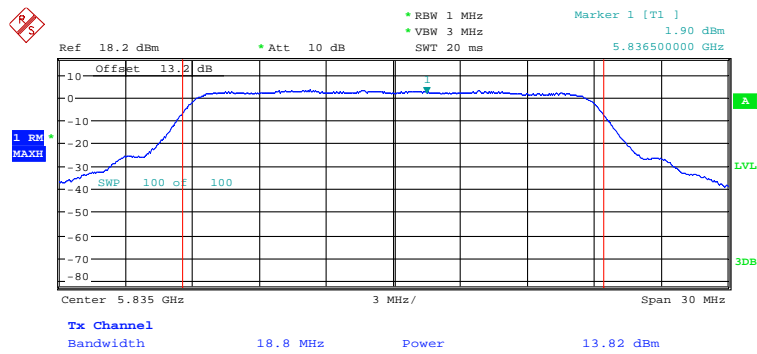

Date: 27.SEP.2015 14:46:36

Antenna 3

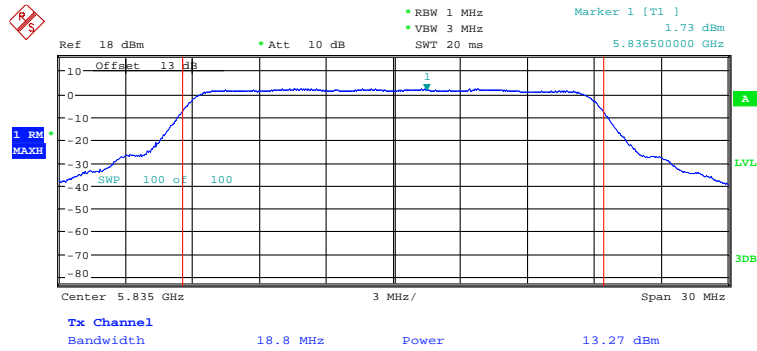

Date: 27.SEP.2015 14:43:57

Antenna 4

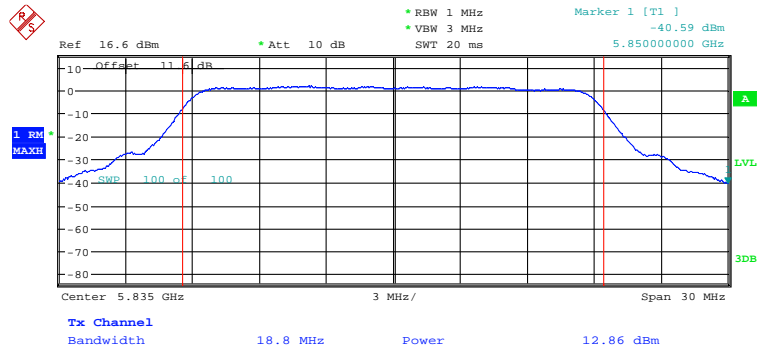

Date: 27.SEP.2015 13:43:10

Case 3-QPSK

Low Channel: 5745 MHz

Antenna 1

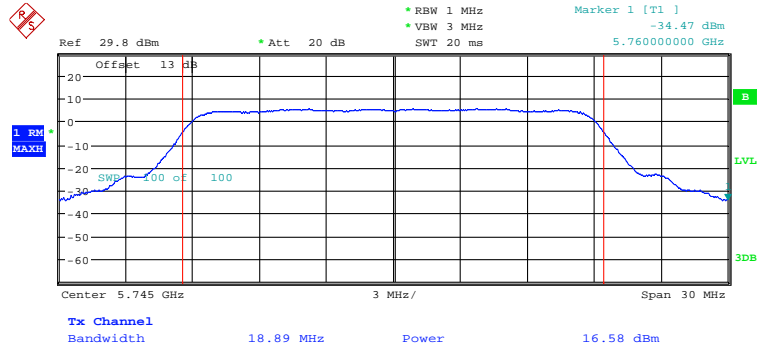

Date: 15.AUG.2015 15:50:34

Antenna 2

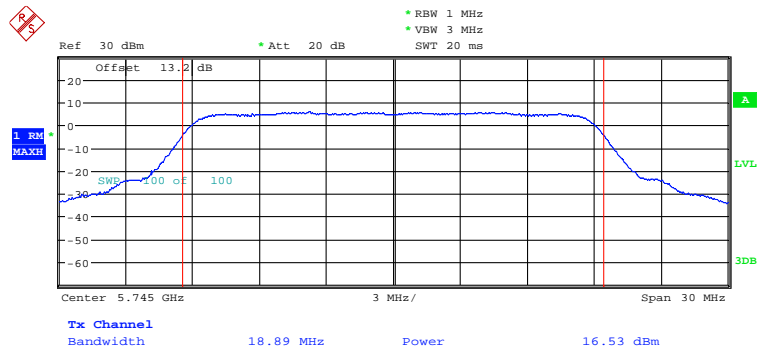

Date: 17.AUG.2015 23:10:01

Antenna 3

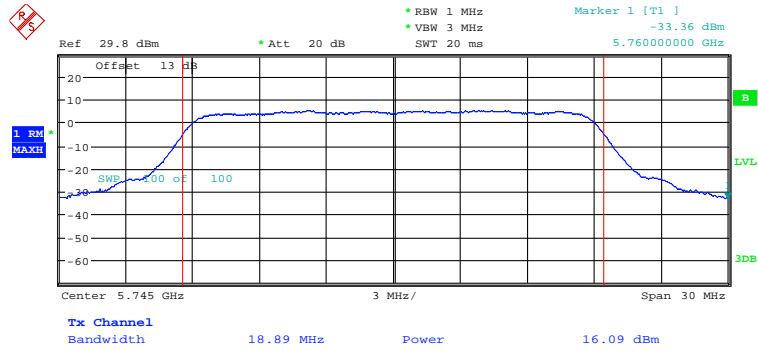

Date: 15.AUG.2015 15:58:46

Antenna 4

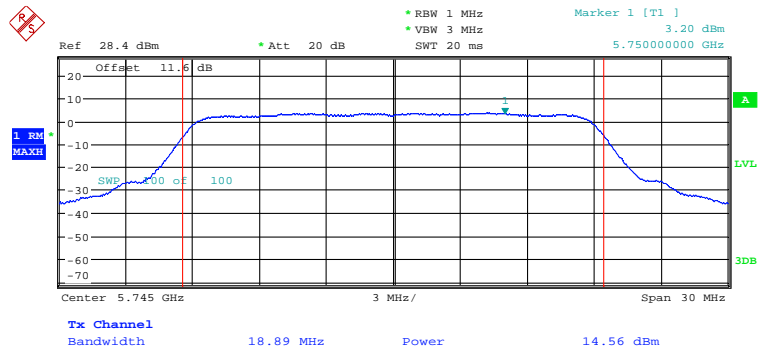

Date: 17.AUG.2015 23:28:35

Middle Channel: 5785 MHz

Antenna 1

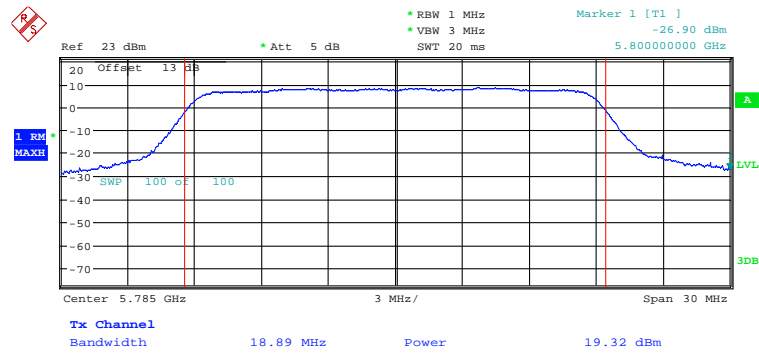

Date: 25.SEP.2015 23:11:18

Antenna 2

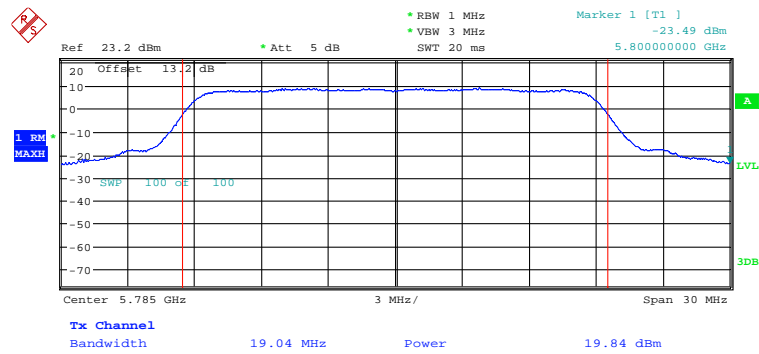

Date: 25.SEP.2015 23:07:09

Antenna 3

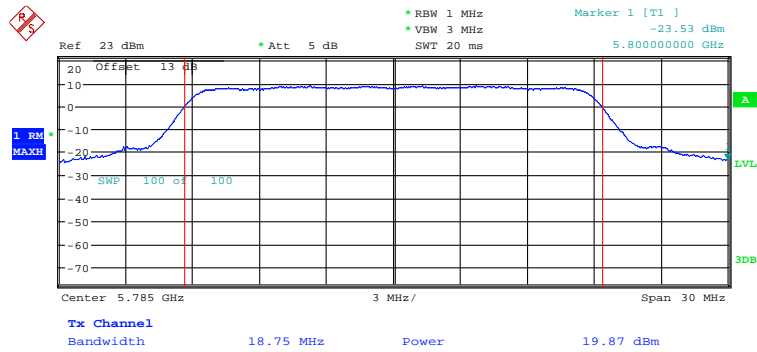

Date: 25.SEP.2015 23:17:54

Antenna 4

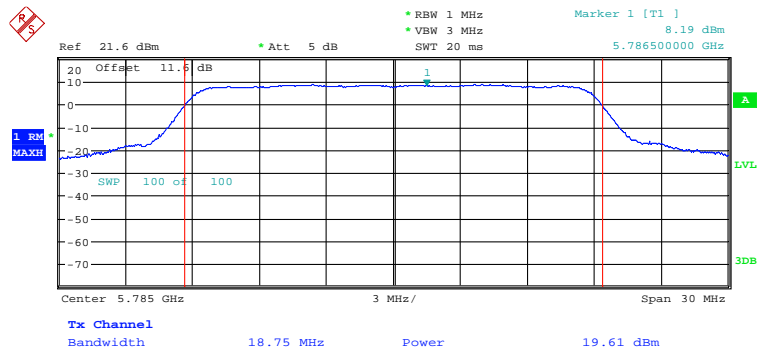

Date: 25.SEP.2015 23:28:00

High Channel: 5835 MHz

Antenna 1

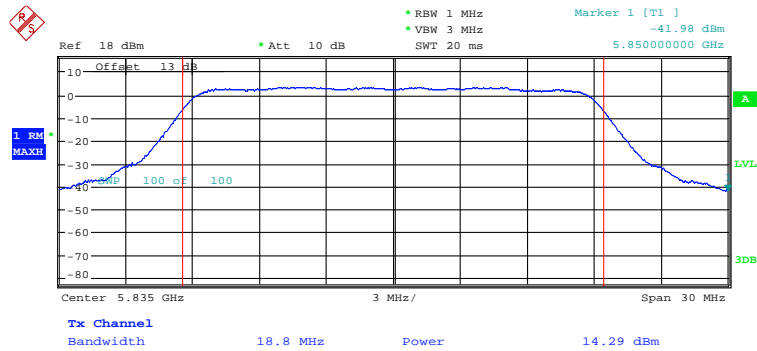

Date: 27.SEP.2015 13:51:27

Antenna 2

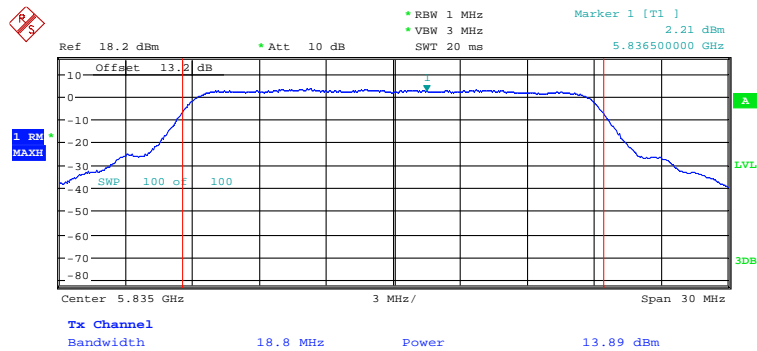

Date: 27.SEP.2015 14:46:00

Antenna 3

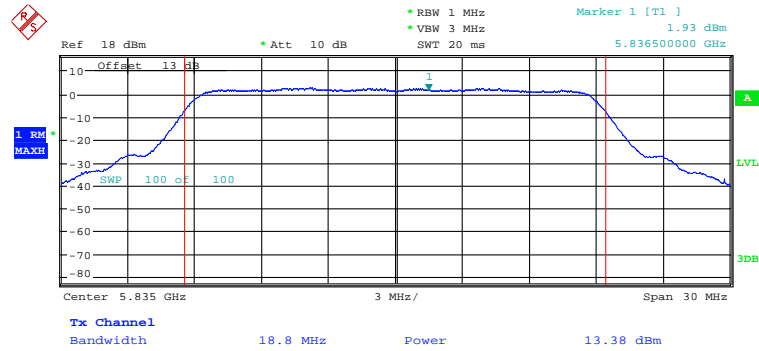

Date: 27.SEP.2015 14:43:17

Antenna 4

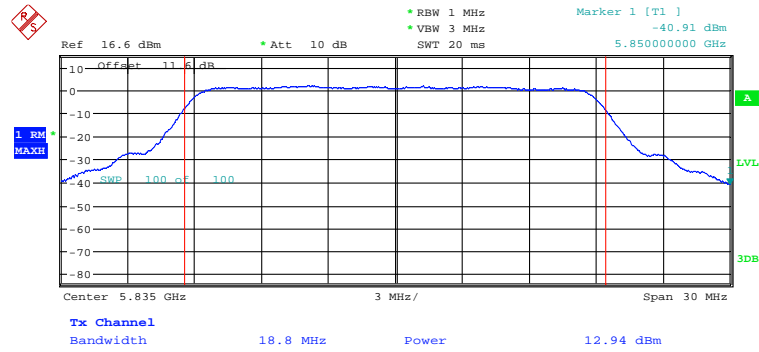

Date: 27.SEP.2015 13:42:27

Case 3-16QAM

Low Channel: 5745 MHz

Antenna 1

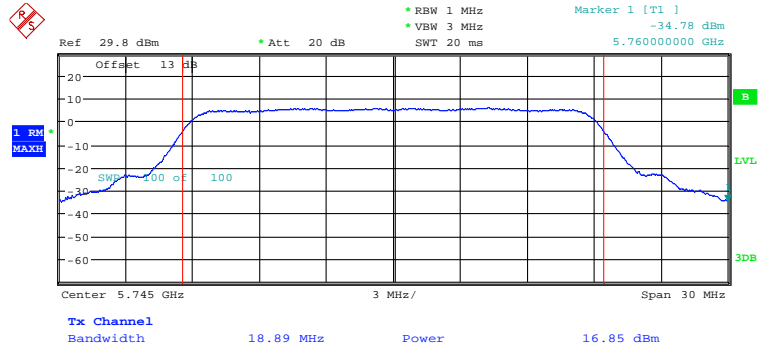

Date: 15.AUG.2015 15:51:14

Antenna 2

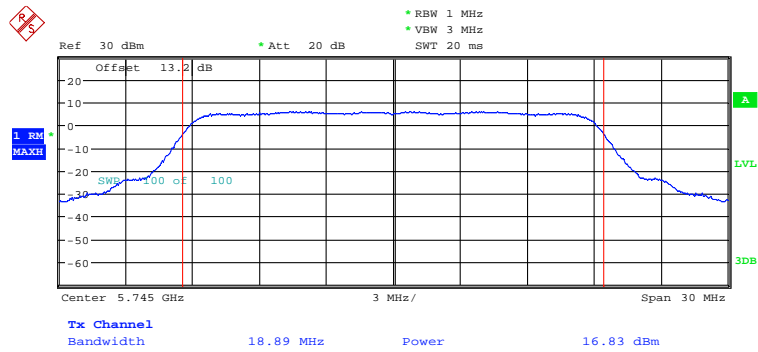

Date: 17.AUG.2015 23:10:58

Antenna 3

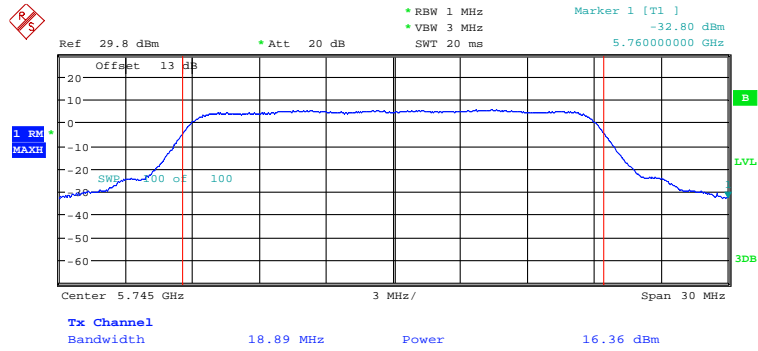

Date: 15.AUG.2015 15:59:14

Antenna 4

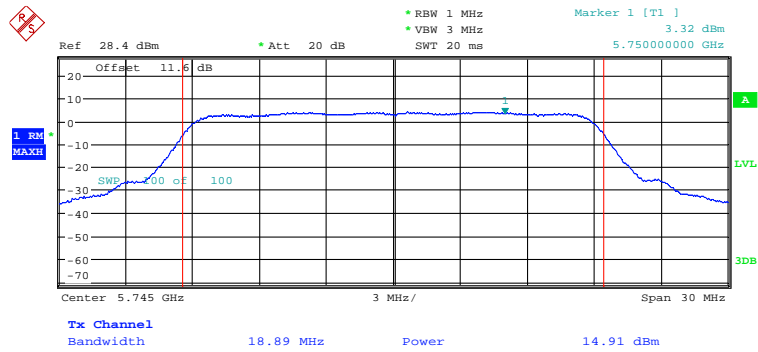

Date: 17.AUG.2015 23:29:04

Middle Channel: 5785 MHz

Antenna 1

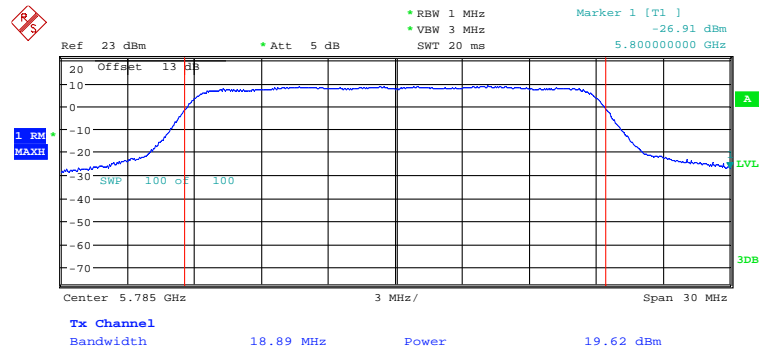

Date: 25.SEP.2015 23:12:14

Antenna 2

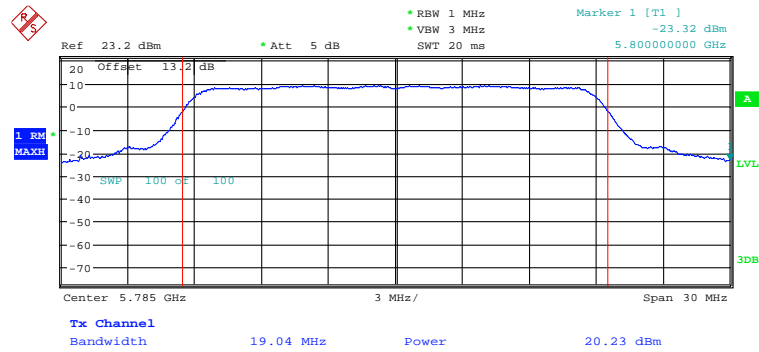

Date: 25.SEP.2015 23:08:12

Antenna 3

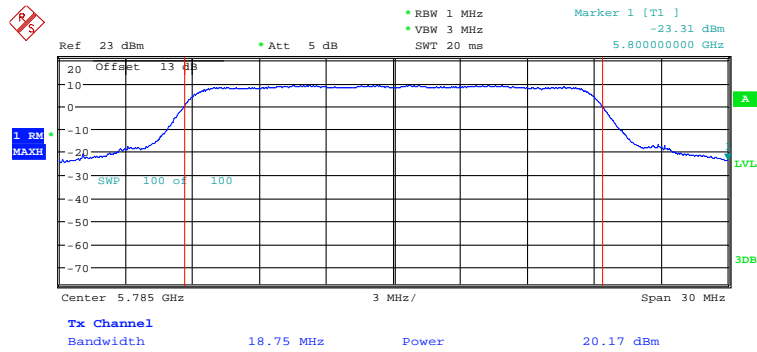

Date: 25.SEP.2015 23:17:14

Antenna 4

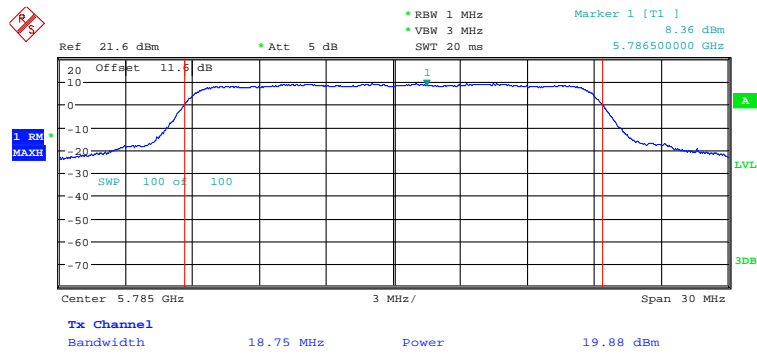

Date: 25.SEP.2015 23:27:25

High Channel: 5835 MHz

Antenna 1

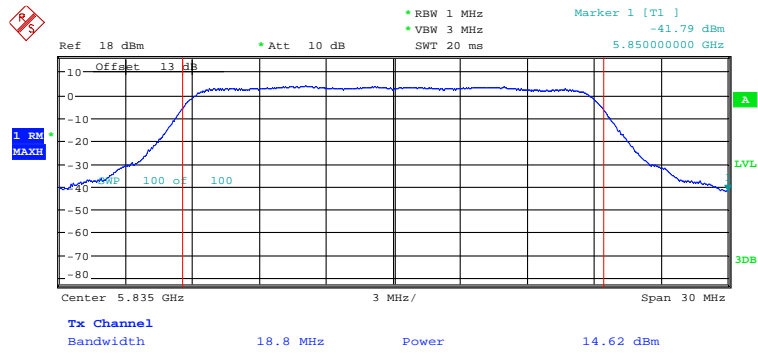

Date: 27.SEP.2015 13:50:46

Antenna 2

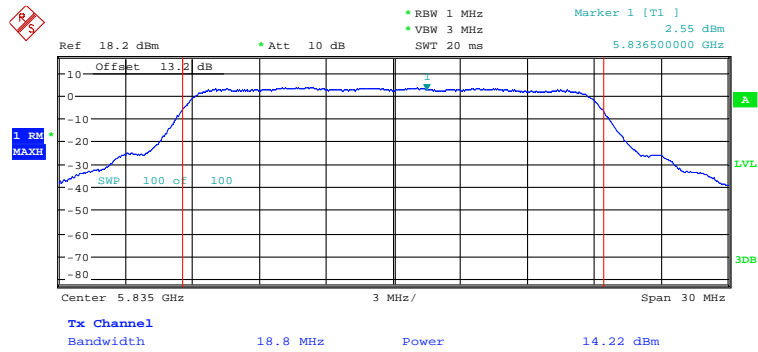

Date: 27.SEP.2015 14:45:27

Antenna 3

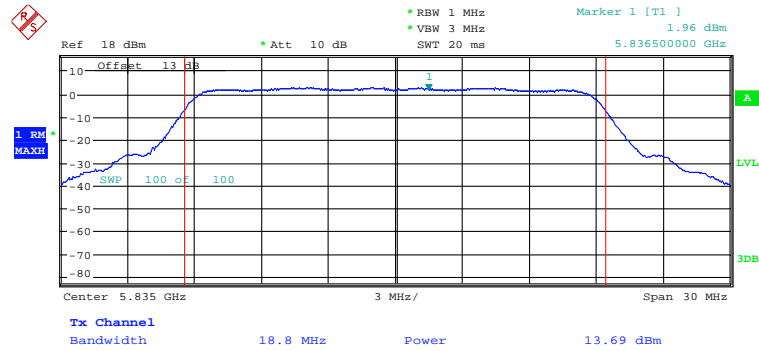

Date: 27.SEP.2015 14:42:43

Antenna 4

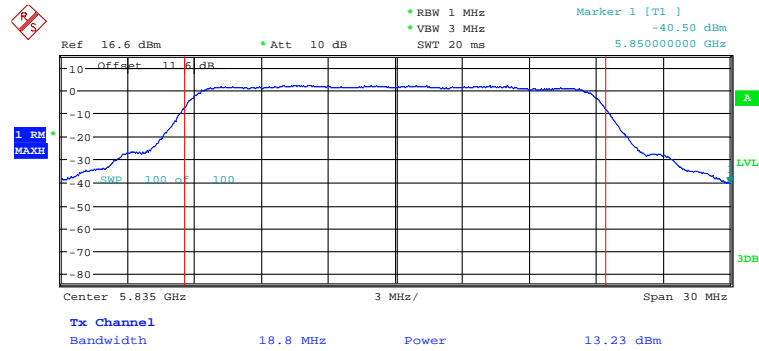

Date: 27.SEP.2015 13:41:39

Case 3-64QAM

Low Channel: 5745 MHz

Antenna 1

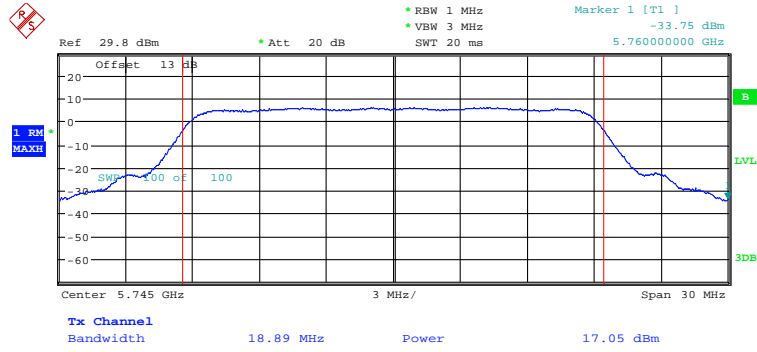

Date: 15.AUG.2015 15:51:50

Antenna 2

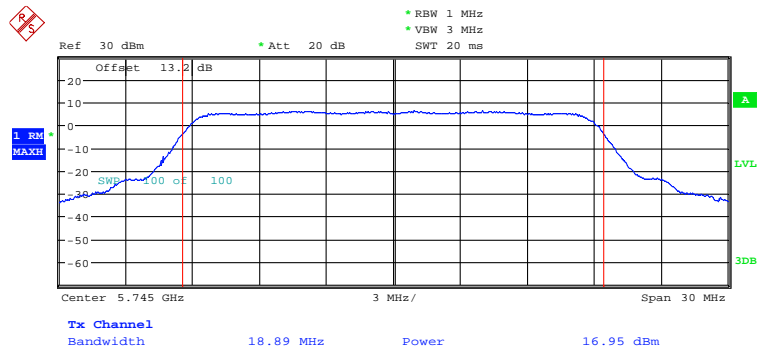

Date: 17.AUG.2015 23:11:30

Antenna 3

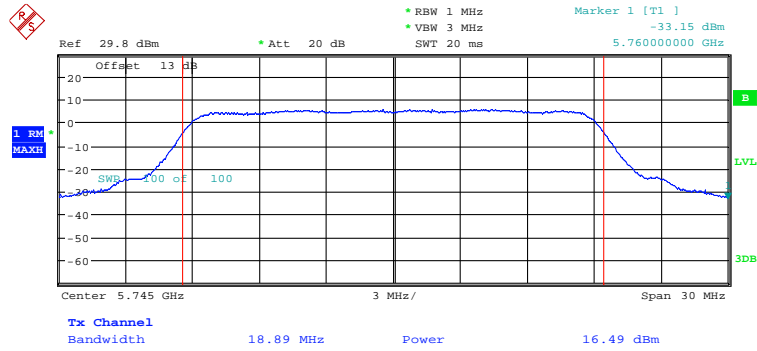

Date: 15.AUG.2015 15:59:48

Antenna 4

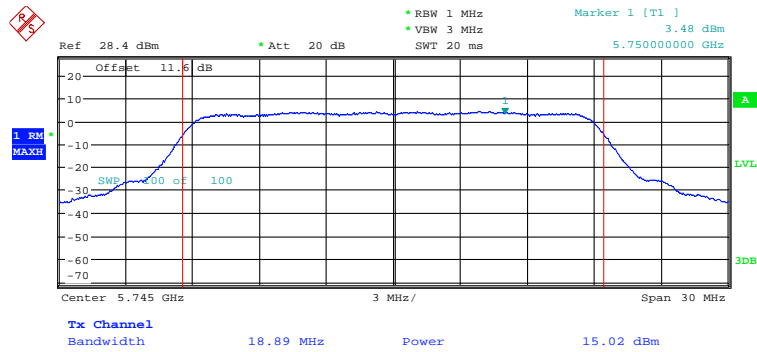

Date: 17.AUG.2015 23:29:32

Middle Channel: 5785 MHz

Antenna 1

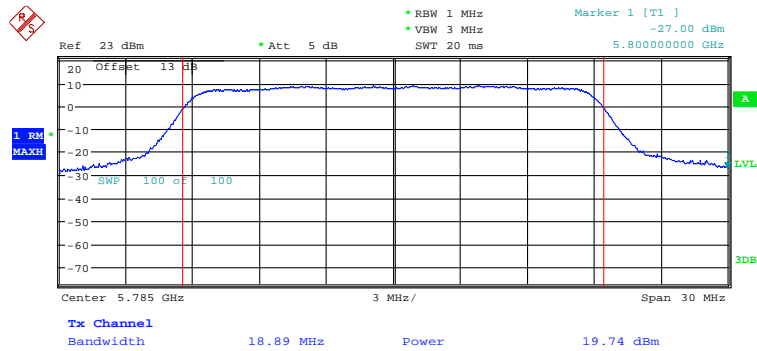

Date: 25.SEP.2015 23:12:55

Antenna 2

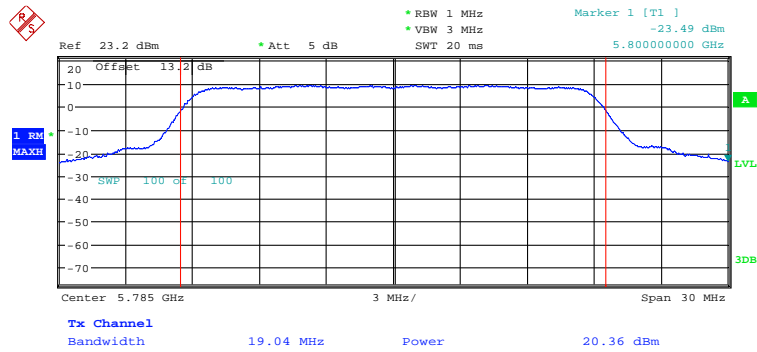

Date: 25.SEP.2015 23:09:03

Antenna 3

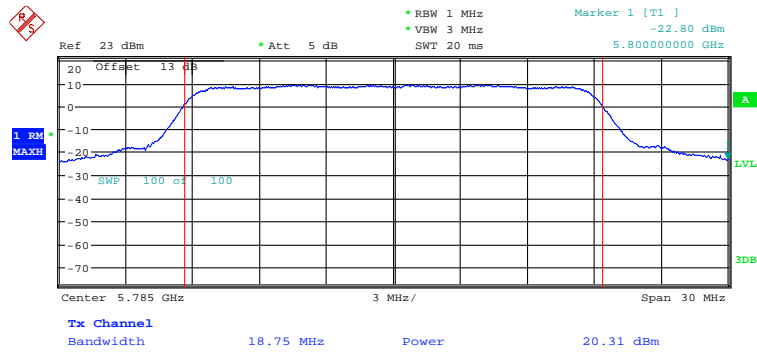

Date: 25.SEP.2015 23:16:03

Antenna 4

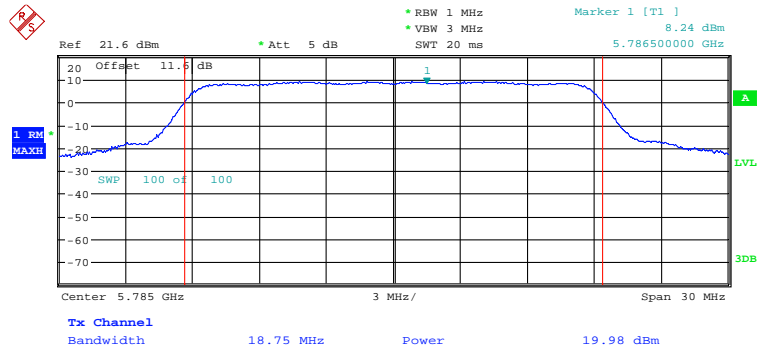

Date: 25.SEP.2015 23:26:36

High Channel: 5835 MHz

Antenna 1

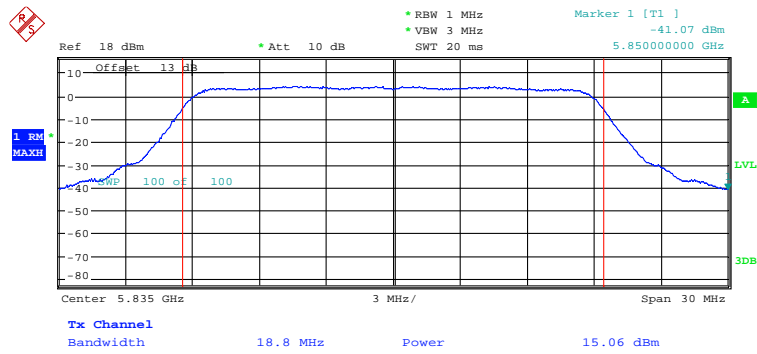

Date: 27.SEP.2015 13:49:25

Antenna 2

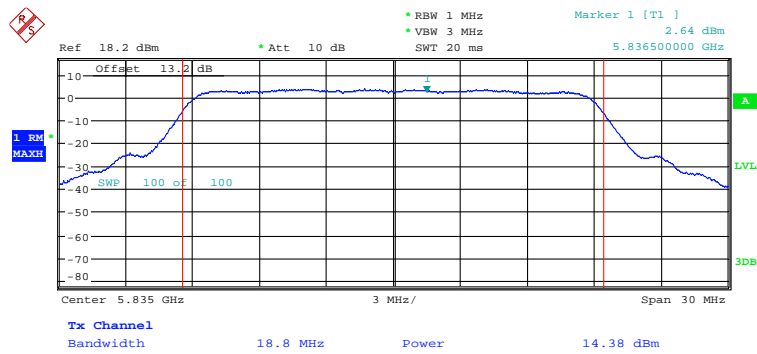

Date: 27.SEP.2015 14:44:39

Antenna 3

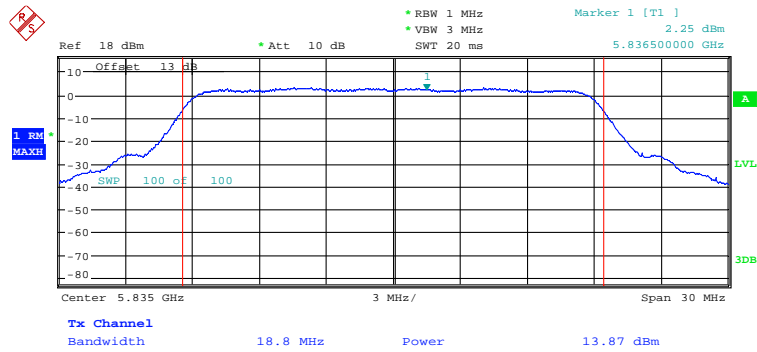

Date: 27.SEP.2015 14:41:47

Antenna 4

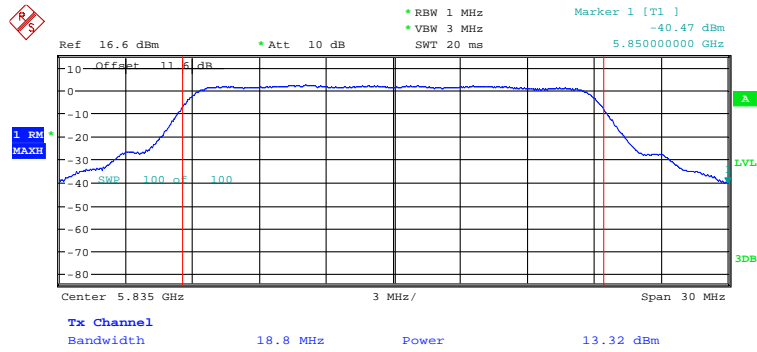

Date: 27.SEP.2015 13:40:45

10 FCC §407(b) & IC RSS-247 §6.2.4 (2) – Band Edge

10.1 Applicable Standards

According to FCC §15.407(b)

b(4) For transmitters operating in the 5.725-5.85 GHz band: All emissions within the frequency range from the band edge to 10 MHz above or below the band edge shall not exceed an e.i.r.p. of -17 dBm/MHz; for frequencies 10 MHz or greater above or below the band edge, emissions shall not exceed an e.i.r.p. of -27 dBm/MHz.

b (5) The emission measurements shall be performed using a minimum resolution bandwidth of 1 MHz. A lower resolution bandwidth may be employed near the band edge, when necessary, provided the measured energy is integrated to show the total power over 1 MHz.

According to IC RSS-247 §6.2.4(2)

For the band 5725-5850 MHz, emissions at frequencies from the band edges to 10 MHz above or below the band edges shall not exceed -17 dBm/MHz e.i.r.p. For emissions at frequencies more than 10 MHz above or below the band edges, the emissions power shall not exceed -27 dBm/MHz.

10.2 Measurement Procedure

Test measurements are based on FCC KDB 789033 D02 General UNII Test Procedures New Rules v01, GUIDELINES FOR COMPLIANCE TESTING OF UNLICENSED NATIONAL INFORAMTION INFRASTRUCTURE (U-NII) DEVICES PART 15, SUBPART E

According to ANSI C63.10-2013, the following procedure shall be used for the marker-delta method:

- a) Perform an in-band field strength measurement of the fundamental emission using the RBW and detector function required for the frequency being measured. For example, for a device operating in the 902 MHz to 928 MHz band, use a 120 kHz RBW with a CISPR QP detector (a peak detector with 100 kHz RBW alternatively may be used). For transmitters operating above 1 GHz, use a 1 MHz RBW, a 3 MHz VBW, and a peak detector, as required. Repeat the measurement with an average detector (or alternatively, a peak detector and reduced VBW). For pulsed emissions, other factors shall be included; see 4.1.4.2.6.
- b) Choose an EMI receiver or spectrum analyzer span that encompasses both the peak of the fundamental emission and the band-edge emission under investigation. Set the instrument RBW to 1% of the total span (but never less than 30 kHz), with a VBW equal to or greater than three times the RBW. Record the peak levels of the fundamental emission and the relevant band-edge emission (i.e., run several sweeps in peak hold mode). Observe the stored trace and measure the amplitude delta between the peak of the fundamental and the peak of the band-edge emission. This is not an absolute field strength measurement; it is only a relative measurement to determine the amount by which the emission drops at the band edge relative to the highest fundamental emission level.
- c) Subtract the delta measured in step b) from the field strengths measured in step a). The resulting field strengths (CISPR QP, average, or peak, as appropriate) are then used to determine band-edge emissions compliance, where required.

10.3 Test Equipment List and Details

Manufacturer	Description	Model No.	Serial No.	Calibration Date	Calibration Interval
R & S	EMI Test Receiver	ESCI 1166.5950K03	100337	2014-09-28	1 year
Agilent	Analyser Spectrom	E4440A	US 42221851	2015-06-23	1 year
Sunol Science Corp	System Controller	SC99V	011003-1	N/R	N/R
EMCO	Antenna, Horn	3115	9511-4627	2015-01-15	1 year
HP/ Agilent	Pre Amplifier	8449B OPT HO2	3008A0113	2015-05-19	1 year
-	SMA cable	-	C0002-6	Each time ¹	N/A
IW Microwave	High Frequency Cable	DC-1438	SPS-2303-3840-SPS	2014-09-23	1 year
Mini-Circuits	Combiner	ZN8PD-642W-S+	SF584201336	Each time ¹	N/A

Note¹: cable and attenuator included in the test set-up will be checked each time before testing.

Statement of Traceability: BACL Corp. BACL Corp. attests that all of the calibrations on the equipment items listed above were traceable to NIST or to another internationally recognized National Metrology Institute (NMI), and were compliant with A2LA Policy P102 (dated 14 May 2015) "A2LA Policy on Metrological Traceability".

10.4 Test Environmental Conditions

Temperature:	22-25° C
Relative Humidity:	40-43 %
ATM Pressure:	102.1-104.4 kPa

The testing was performed by Simon Ma from 2015-08-15 to 2015-08-19 at RF site and 5meter chamber3.

10.5 Test Results

Please refer to the following tables and plots.

Only 64QAM was tested for each case and each antenna chain since its output power is the highest.

Test mode: Case 1

Frequency (MHz)	Tested Frequency (MHz)	Band-Edge (dBm)	FCC/IC Limit (dBm)
Low CH - 5745 MHz	5724.50	-22.63	-17
	5714.50	-30.56	-27
High CH - 5835 MHz	5850.50	-19.47	-17
	5860.50	-27.37	-27

Test mode: Case 2

Frequency (MHz)	Tested Frequency (MHz)	Band-Edge (dBm)	FCC/IC Limit (dBm)
Low CH - 5755 MHz	5724.50	-17.26	-17
	5714.50	-27.41	-27
High CH - 5825 MHz	5850.50	-20.94	-17
	5860.50	-27.55	-27

Test mode: Case 3

Frequency (MHz)	Antenna	Tested Frequency (MHz)	Band-Edge (dBm)	FCC/IC Limit (dBm)
Low CH - 5745 MHz	1	5724.50	-17.81	-17
		5714.50	-28.72	-27
	2	5724.50	-17.29	-17
		5714.50	-29.43	-27
	3	5724.50	-17.19	-17
		5714.50	-29.77	-27
	4	5724.50	-17.10	-17
		5714.50	-30.94	-27
High CH - 5835 MHz	1	5850.50	-19.7	-17
		5860.50	-27.91	-27
	2	5850.50	-17.37	-17
		5860.50	-27.19	-27
	3	5850.50	-17.4	-17
		5860.50	-28.27	-27
	4	5850.50	-17.88	-17
		5860.50	-29.2	-27

Please refer to the following plots for the test results of Case3, which is the case that has the highest conducted power. The offset in the plots below includes antenna gain, cable loss and the path loss of the combiner.

Low Channel – 5745 MHz

Antenna 1: -17 dBm/MHz

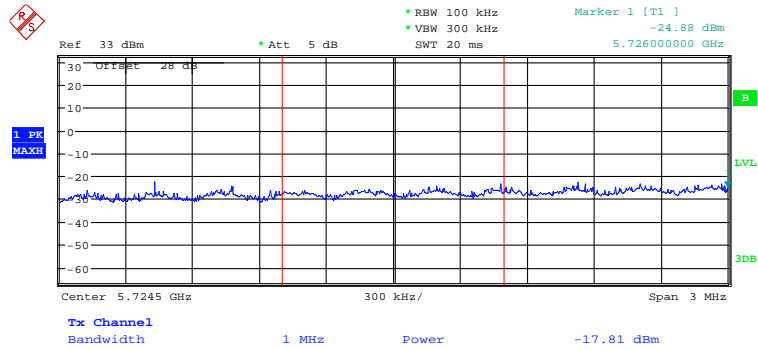

Date: 15.AUG.2015 21:14:56

Antenna 1: -27 dBm/MHz

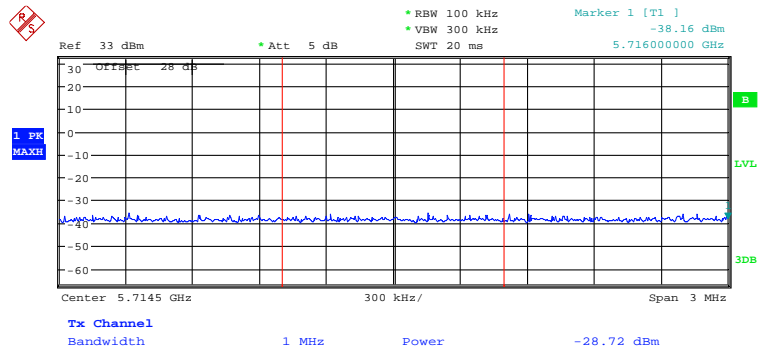

Date: 15.AUG.2015 21:15:13

Antenna 2: -17 dBm/MHz

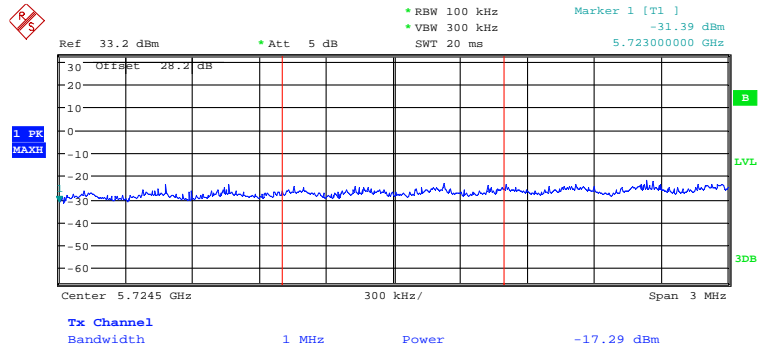

Date: 15.AUG.2015 21:21:30

Antenna 2: -27 dBm/MHz

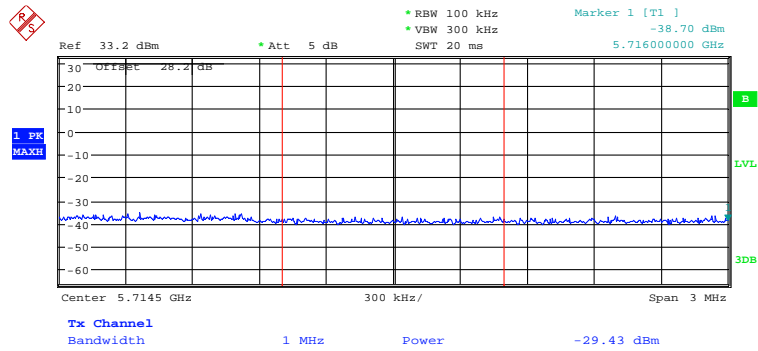

Date: 15.AUG.2015 21:21:43

Antenna 3: -17 dBm/MHz

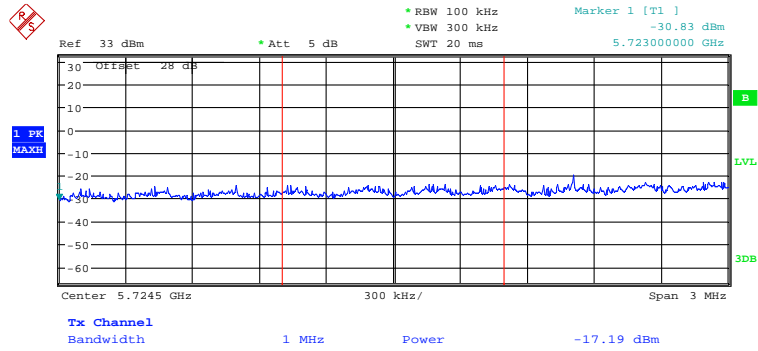

Date: 15.AUG.2015 21:22:20

Antenna 3: -27 dBm/MHz

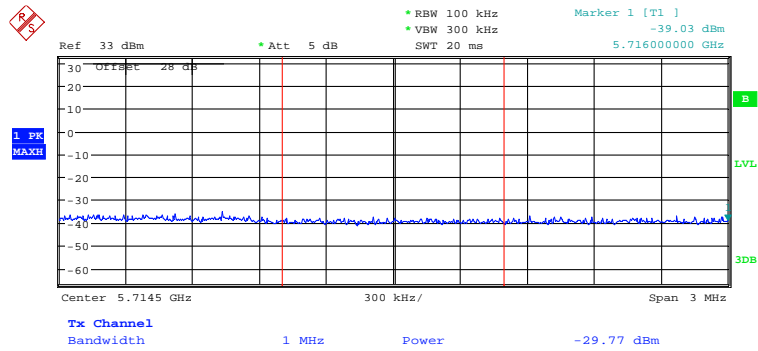

Date: 15.AUG.2015 21:22:56

Antenna 4: -17 dBm/MHz

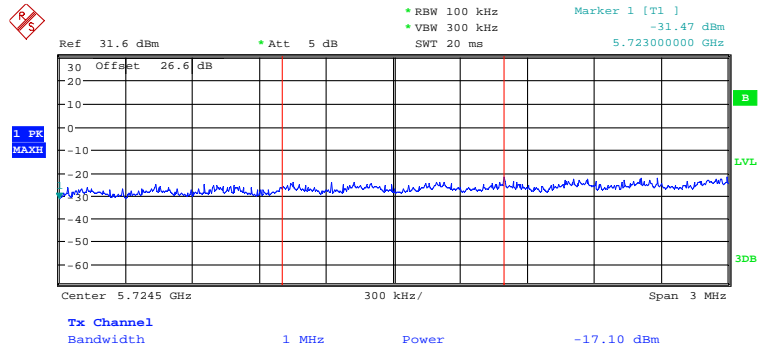

Date: 15.AUG.2015 21:24:28

Antenna 4: -27 dBm/MHz

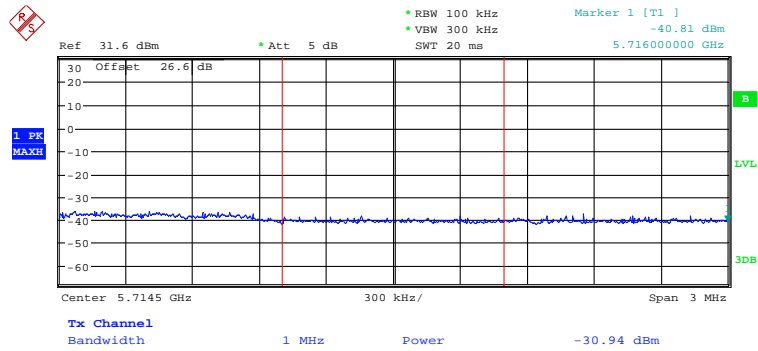

Date: 15.AUG.2015 21:25:27

High Channel – 5835 MHz

Antenna 1: -17 dBm/MHz

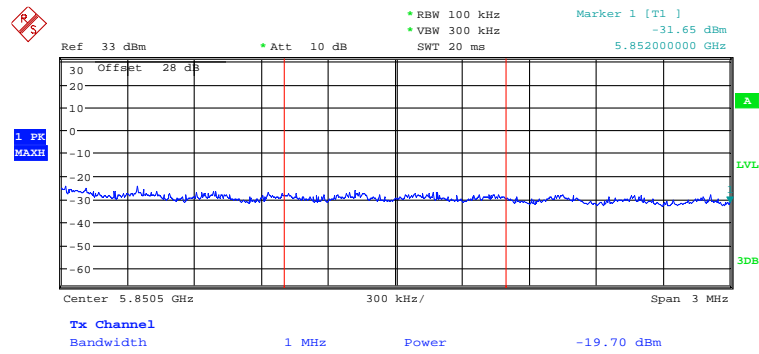

Date: 27.SEP.2015 13:23:39

Antenna 1: -27 dBm/MHz

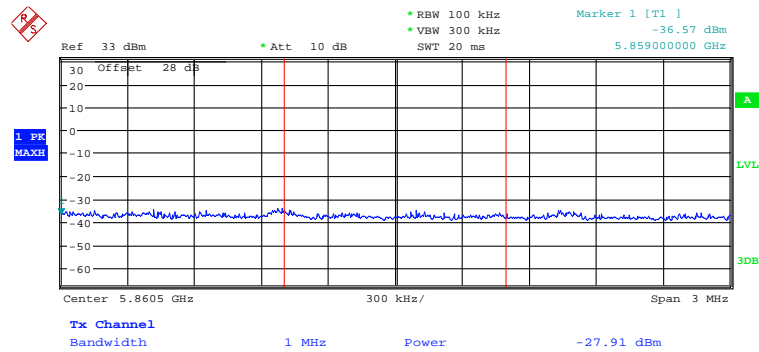

Date: 27.SEP.2015 13:24:50

Antenna 2: -17 dBm/MHz

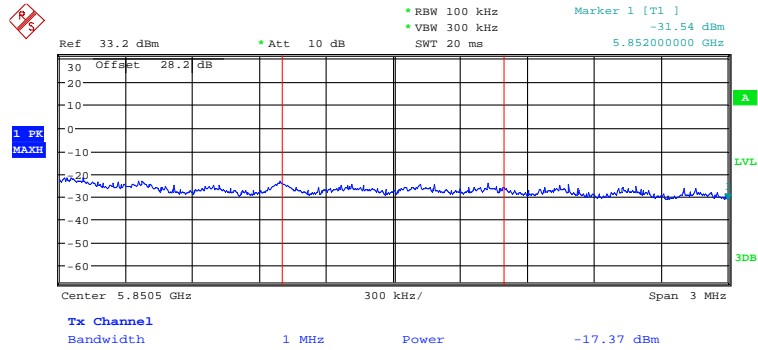

Date: 27.SEP.2015 13:56:14

Antenna 2: -27 dBm/MHz

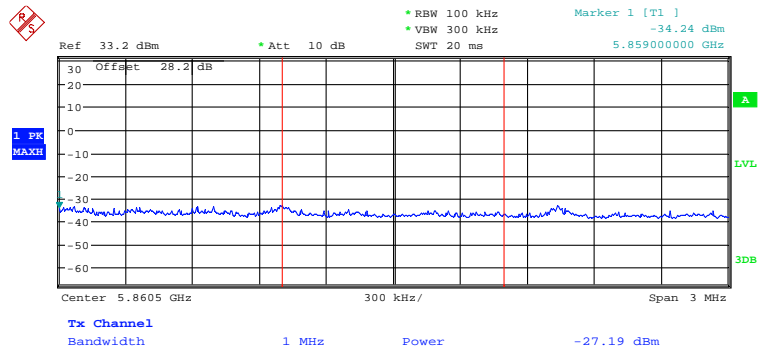

Date: 27.SEP.2015 13:55:38

Antenna 3: -17 dBm/MHz

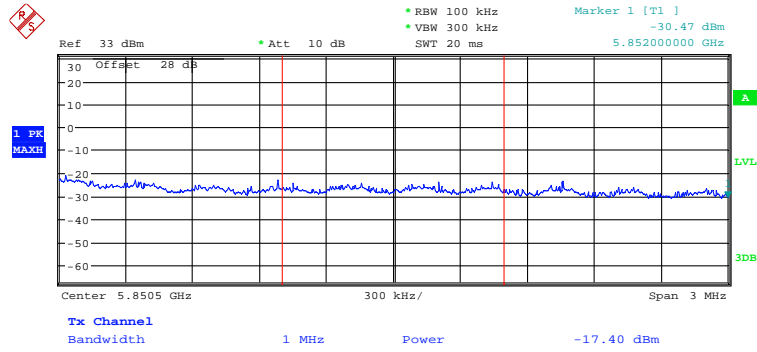

Date: 27.SEP.2015 13:57:02

Antenna 3: -27 dBm/MHz

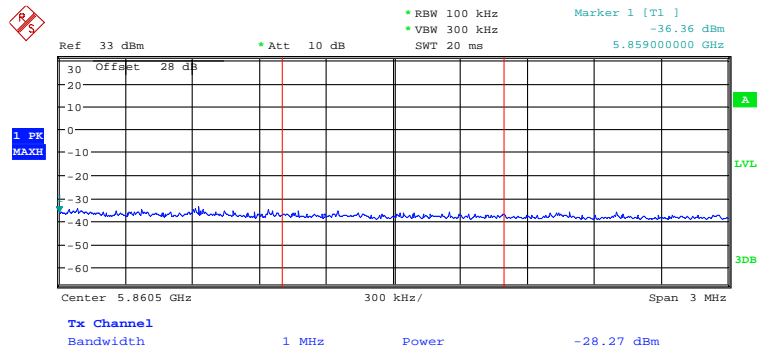

Date: 27.SEP.2015 13:57:32

Antenna 4: -17 dBm/MHz

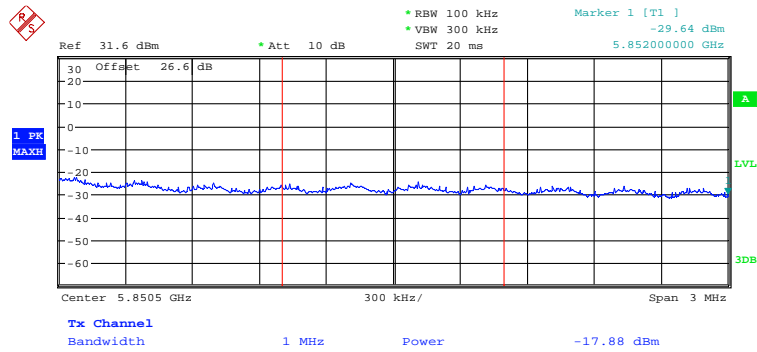

Date: 27.SEP.2015 13:32:12

Antenna 4: -27 dBm/MHz

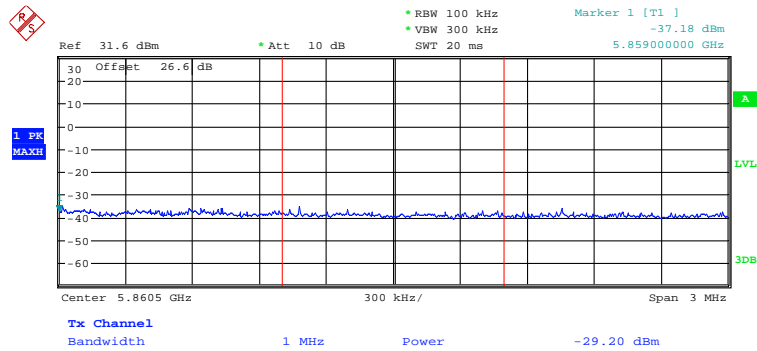

Date: 27.SEP.2015 13:33:39

11 FCC §15.407(a) & IC RSS-247 §6.2.4 (1) - Power Spectral Density

11.1 Applicable Standards

According to FCC §15.407(a)

(3) For the band 5.725-5.85 GHz, the maximum conducted output power over the frequency band of operation shall not exceed 1 W. In addition, the maximum power spectral density shall not exceed 30 dBm in any 500-kHz band. If transmitting antennas of directional gain greater than 6 dBi are used, both the maximum conducted output power and the maximum power spectral density shall be reduced by the amount in dB that the directional gain of the antenna exceeds 6 dBi.

According to IC RSS-247 §6.2.4(1)

For equipment operating in the band 5725-5850 MHz, the minimum 6 dB bandwidth shall be at least 500 kHz. Digital Transmission Systems (DTSs), Frequency Hopping Systems (FHSs) and Licence-Exempt Local Area Network (LE-LAN) Devices RSS-247 10 The maximum conducted output power shall not exceed 1 W. The power spectral density shall not exceed 30 dBm in any 500 kHz band. If transmitting antennas of directional gain greater than 6 dBi are used, both the maximum conducted output power and the power spectral density shall be reduced by the amount in dB that the directional gain of the antenna exceeds 6 dBi. However, fixed point-to-point devices operating in this band may employ transmitting antennas with directional gain greater than 6 dBi without any corresponding reduction in transmitter conducted power. Fixed point-to-point operations exclude the use of point-to-multipoint³ systems, omnidirectional applications and multiple collocated transmitters transmitting the same information.

11.2 Measurement Procedure

The measurements are base on FCC KDB 789033 D02 General UNII Test Procedures New Rules v01: Guidelines for Compliance Testing of Unlicensed National Information Infrastructure (U-NII) Devices section F: Peak power spectral density (PPSD)

11.3 Test Equipment List and Details

Manufacturer	Description	Model No.	Serial No.	Calibration Date	Calibration Interval
R & S	Signal Analyzer	FSQ	1155.5001.26	2015-03-09	1 year
-	SMA cable	-	C0002-6	Each time ¹	N/A
Mini-Circuits	Combiner	ZN8PD-642W-S+	SF584201336	Each time ¹	N/A

Note¹: cable and attenuator included in the test set-up will be checked each time before testing.

Statement of Traceability: BACL Corp. BACL Corp. attests that all of the calibrations on the equipment items listed above were traceable to NIST or to another internationally recognized National Metrology Institute (NMI), and were compliant with A2LA Policy P102 (dated 14 May 2015) "A2LA Policy on Metrological Traceability".

11.4 Test Environmental Conditions

Temperature:	25° C
Relative Humidity:	45 %
ATM Pressure:	104.4 kPa

The testing was performed by Simon Ma on 2015-08-15 at RF site.

11.5 Test Results

Please refer to the following tables and plots.

Only 64QAM was tested for each case and each antenna chain since its output power is the highest.

Case 1

Frequency (MHz)	Modulation	PSD (dBm/500 kHz)				Total (mW)	Total (dBm)	Limit ¹ (dBm/500 kHz)
		ANT 1	ANT 2	ANT 3	ANT 4			
5745	64QAM	0.16	-1.44	0.07	-0.65	3.63	5.60	18
5785	64QAM	1.01	-1.13	0.14	-0.36	3.99	6.01	18
5835	64QAM	0.03	-0.30	-0.48	-1.43	3.55	5.51	18

Note 1: 4 antennas are correlated in case1, antenna1 and antenna3 are in same polarization; antenna2 and antenna4 are in same polarization. The directional antenna gain is $15 \text{ dBi} + 10 \cdot \log(2) = 18 \text{ dBi}$. Directional antenna gain exceeds 6 dBi by 12 dB. Thus the limit is $30 - (18 - 6) = 18 \text{ dBm}$.

Case 2

Frequency (MHz)	Modulation	PSD (dBm/500 kHz)		Total (mW)	Total (dBm)	Limit ² (dBm/500 kHz)
		ANT 1 & 3	ANT 2 & 4			
5755	64QAM	3.93	2.96	4.45	6.48	21
5785	64QAM	2.40	3.30	3.88	5.88	21
5825	64QAM	3.67	3.51	4.57	6.60	21

Case 3

Frequency (MHz)	Modulation	Antenna	PSD (dBm/500 kHz)	Limit ² (dBm/500 kHz)
5745	64QAM	1	5.47	21
	64QAM	2	4.83	21
	64QAM	3	5.38	21
	64QAM	4	2.68	21
5785	64QAM	1	8.25	21
	64QAM	2	8.73	21
	64QAM	3	8.54	21
	64QAM	4	8.77	21
5835	64QAM	1	2.68	21
	64QAM	2	2.40	21
	64QAM	3	1.75	21
	64QAM	4	1.46	21

Note 2: 4 antennas are fully un-correlated in case 2 and case 3. The directional antenna gain is 15 dBi, which is 9 dB exceeds 6 dBi. Thus the limit is $30 - (15 - 6) = 21$ dBm.

Case 1

Low Channel-5745 MHz

Antenna 1

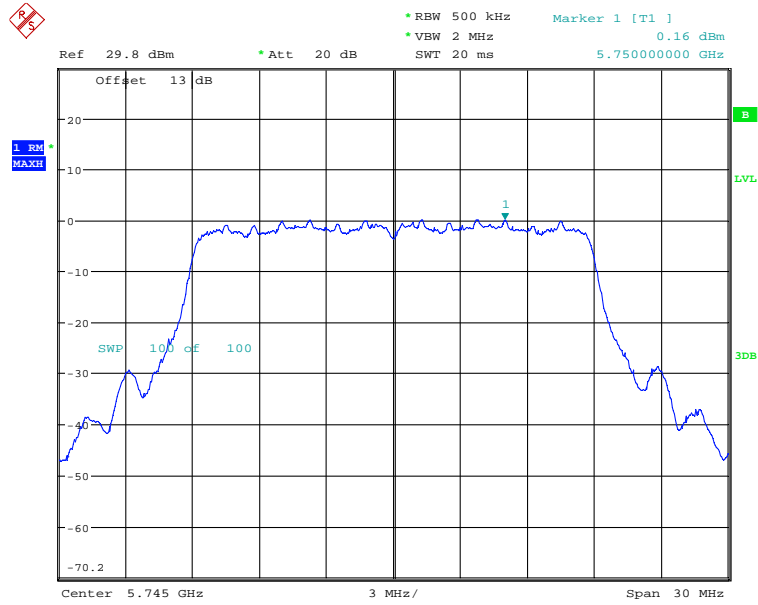

Date: 15.AUG.2015 19:41:51

Antenna 2

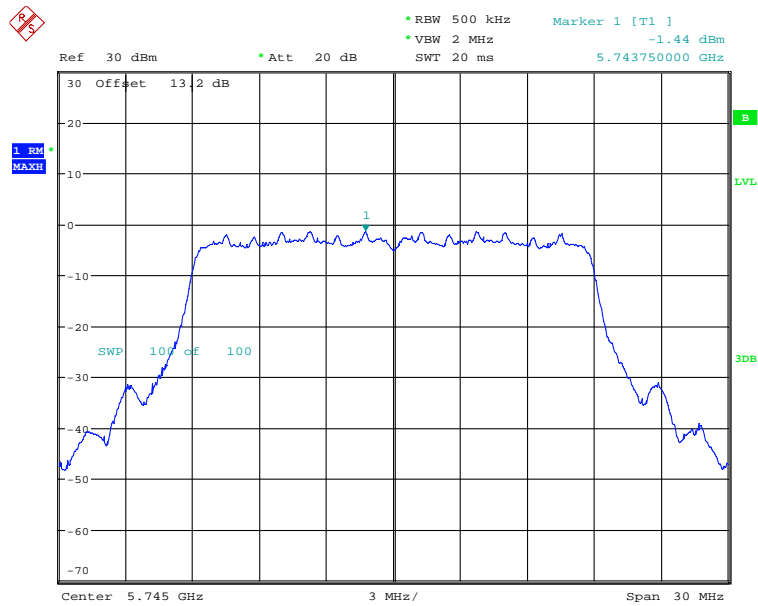

Date: 15.AUG.2015 19:44:35

Antenna 3

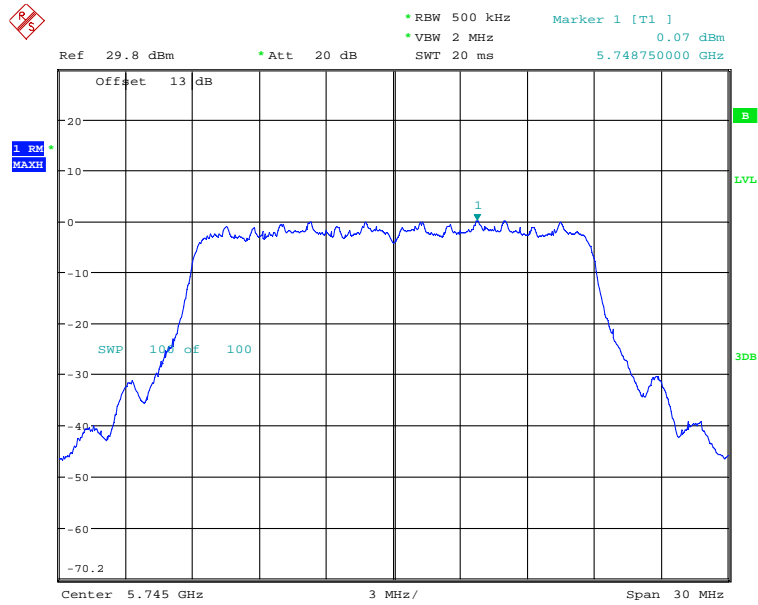

Date: 15.AUG.2015 19:43:33

Antenna 4

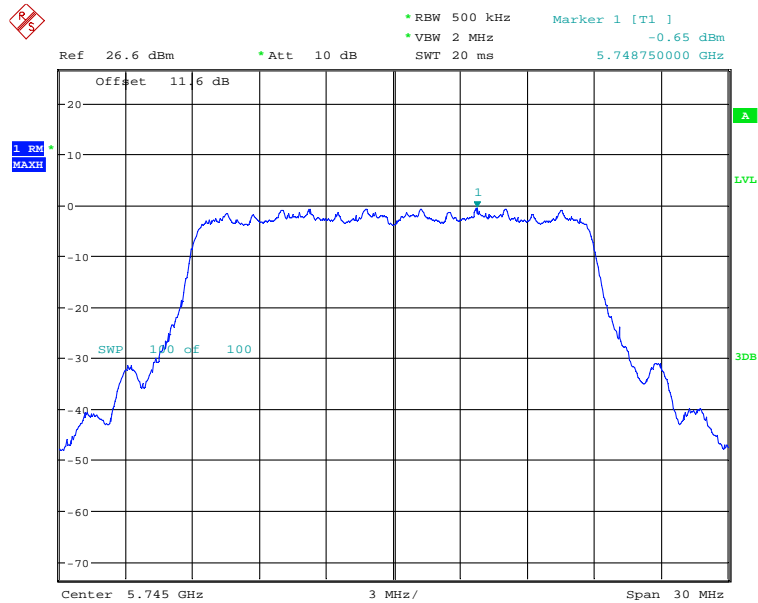

Date: 19.AUG.2015 16:19:19

Middle Channel-5785 MHz

Antenna 1

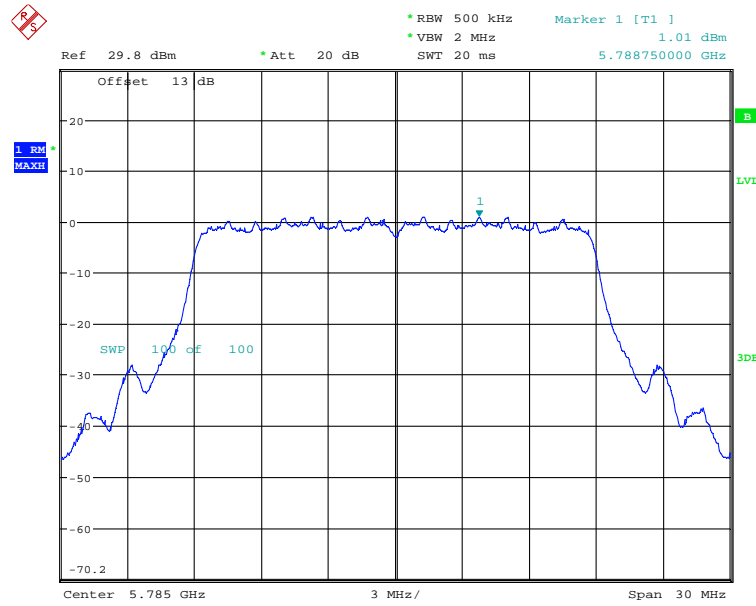

Date: 15.AUG.2015 19:47:09

Antenna 2

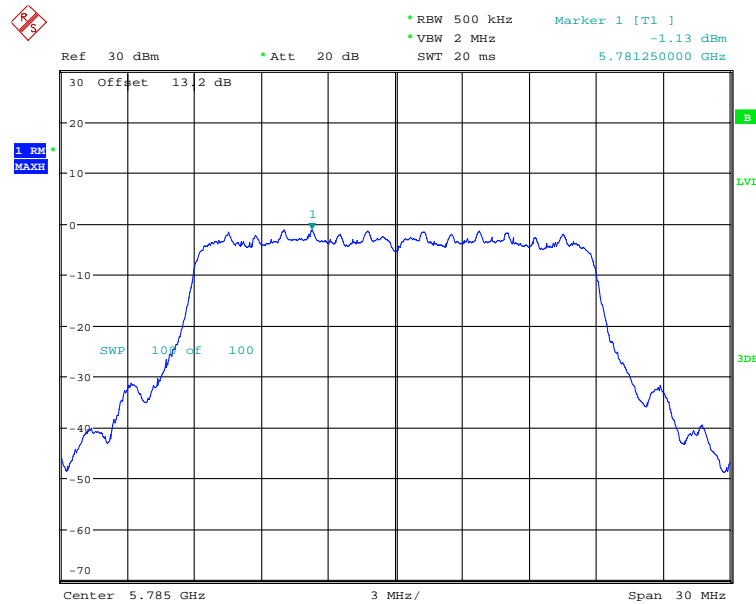

Date: 15.AUG.2015 19:47:36

Antenna 3

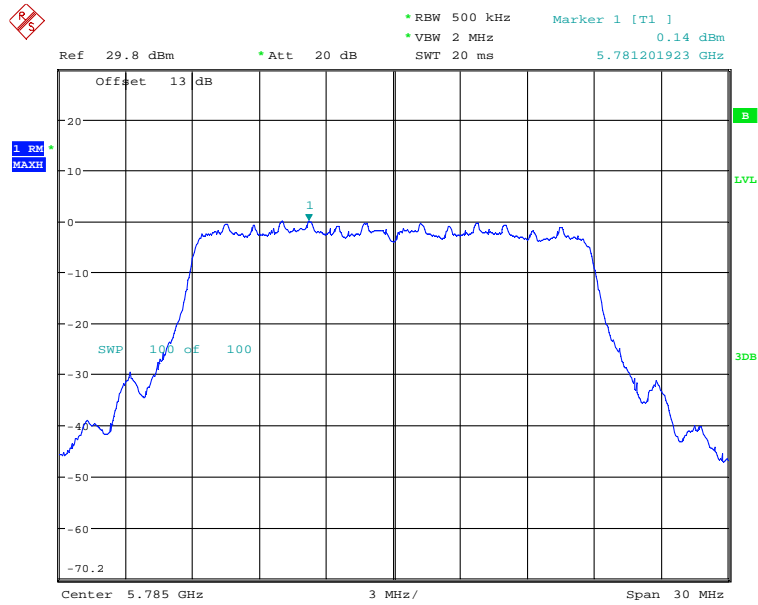

Date: 15.AUG.2015 19:48:46

Antenna 4

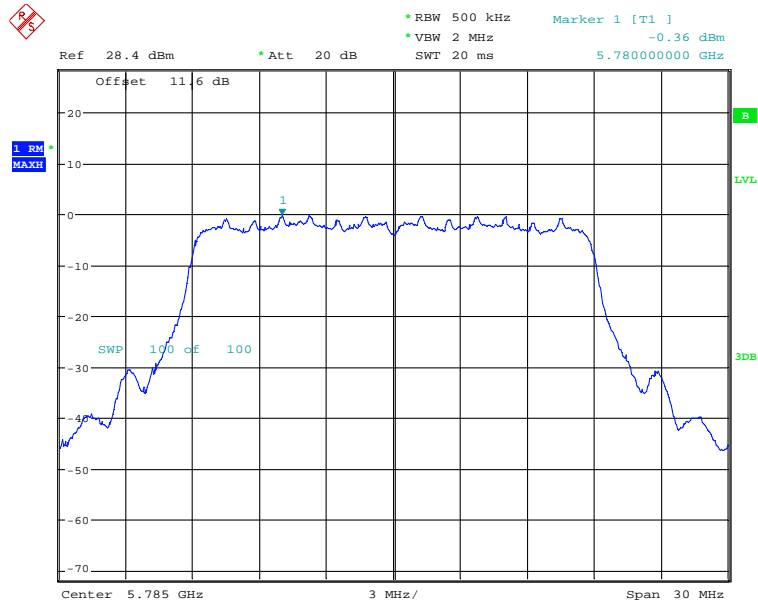

Date: 15.AUG.2015 19:49:19

High Channel-5835 MHz

Antenna 1

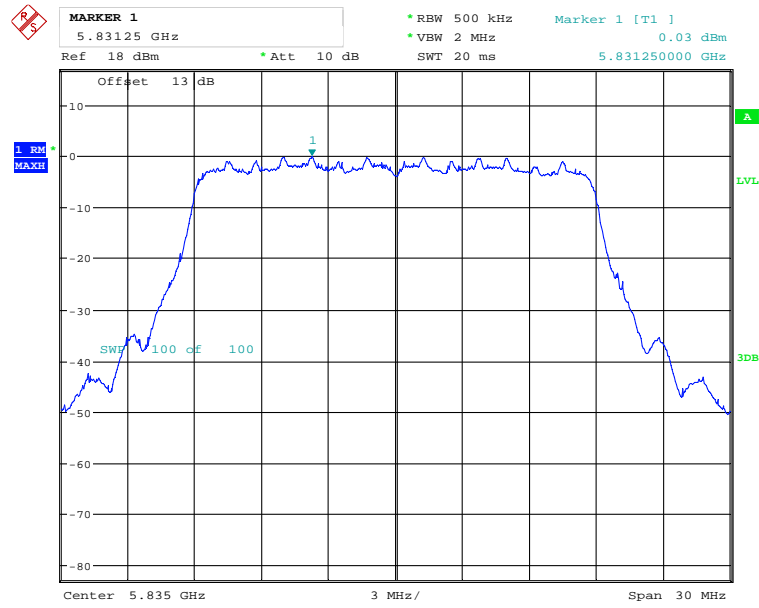

Date: 27.SEP.2015 19:12:16

Antenna 2

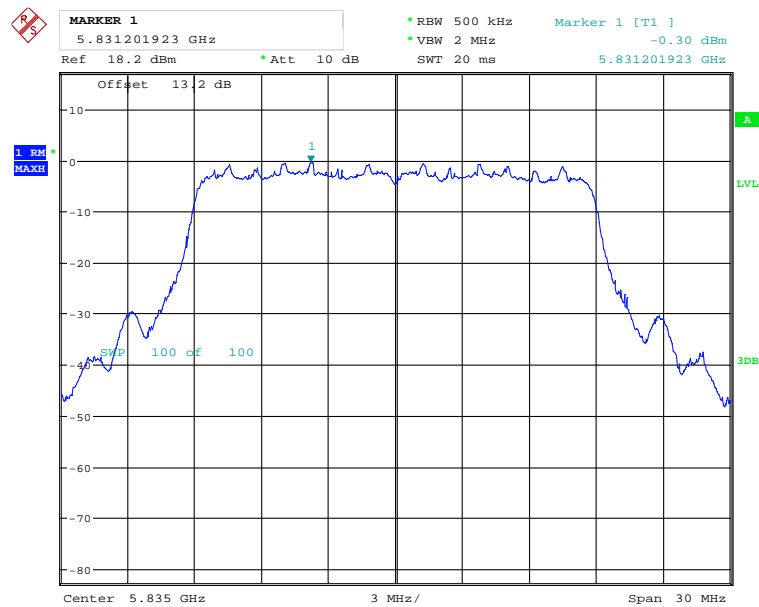

Date: 27.SEP.2015 19:14:10

Antenna 3

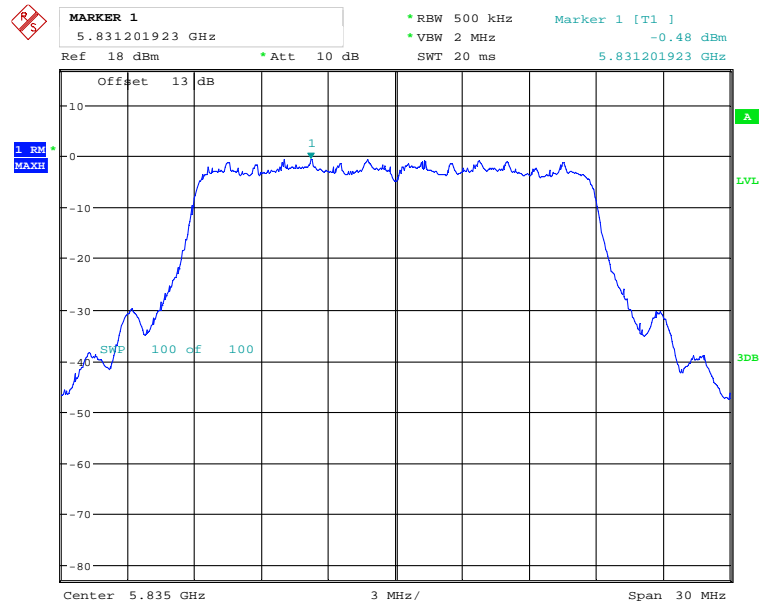

Date: 27.SEP.2015 19:16:45

Antenna 4

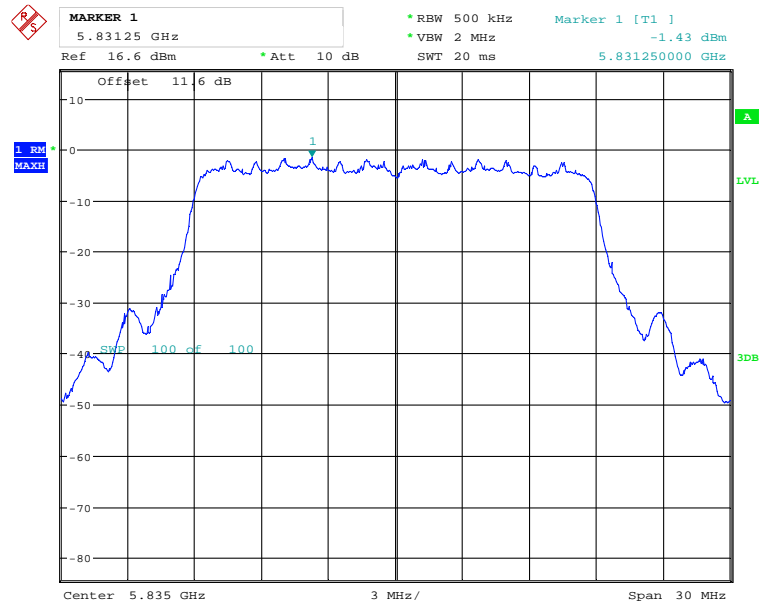

Date: 27.SEP.2015 19:18:34

Case 2

Low Channel-5755 MHz

Antenna 1 & 3

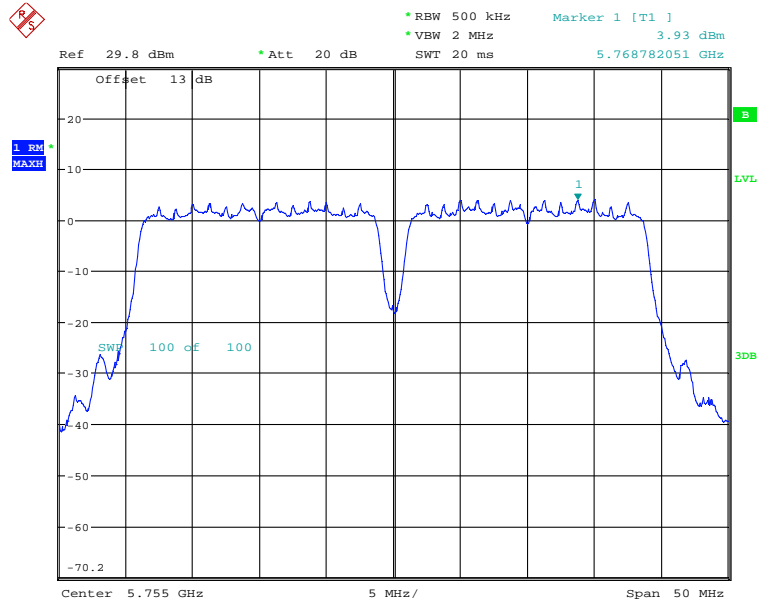

Date: 15.AUG.2015 20:10:20

Antenna 2 & 4

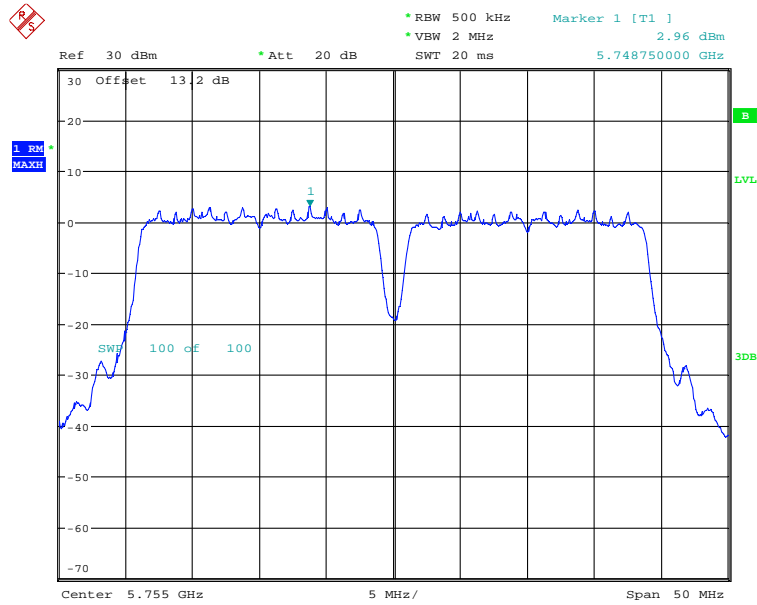

Date: 15.AUG.2015 20:10:48

Middle Channel-5785 MHz

Antenna 1 & 3

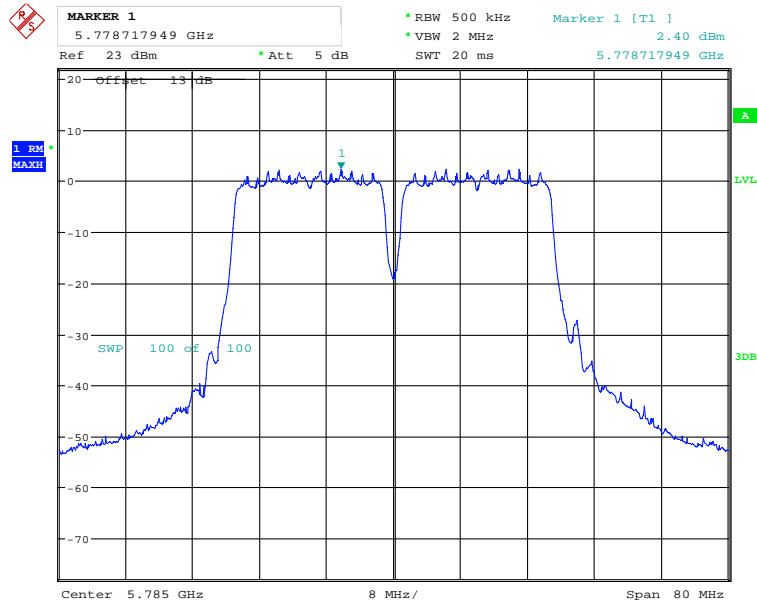

Date: 27.SEP.2015 12:58:40

Antenna 2 & 4

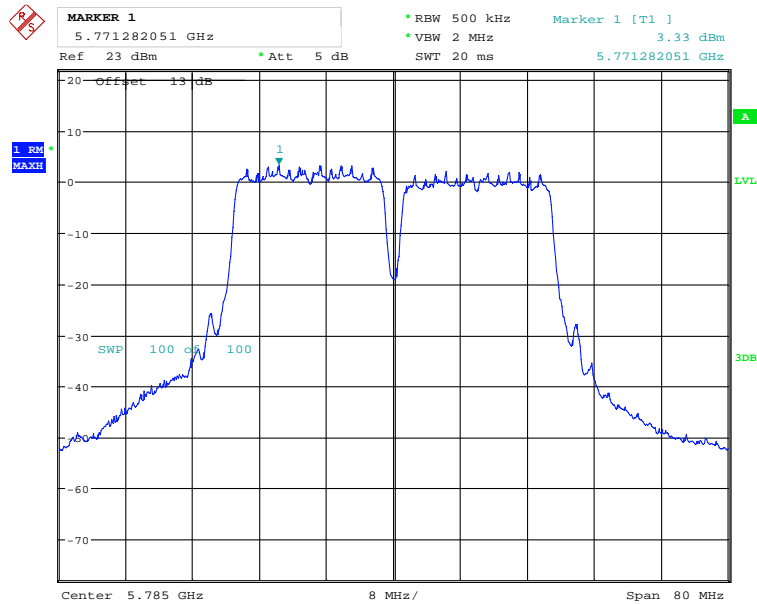

Date: 27.SEP.2015 12:56:52

High Channel-5825 MHz

Antenna 1 & 3

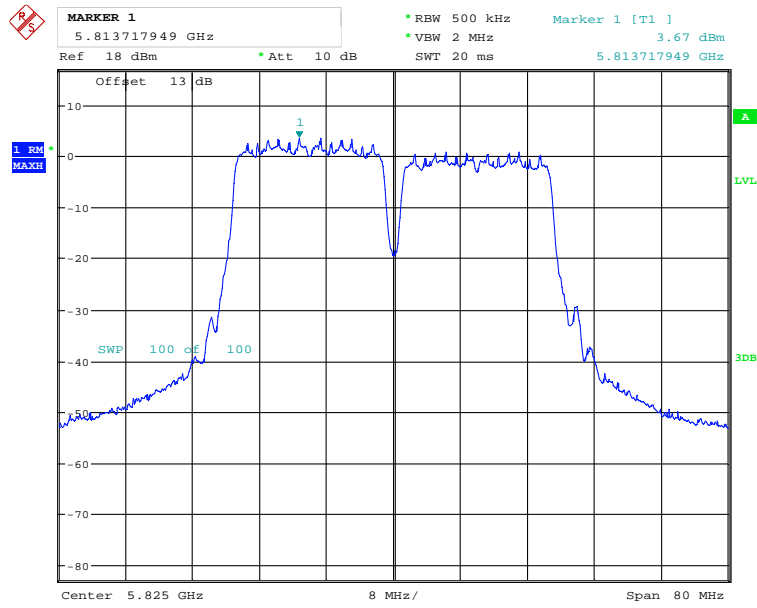

Date: 27.SEP.2015 17:58:04

Antenna 2 & 4

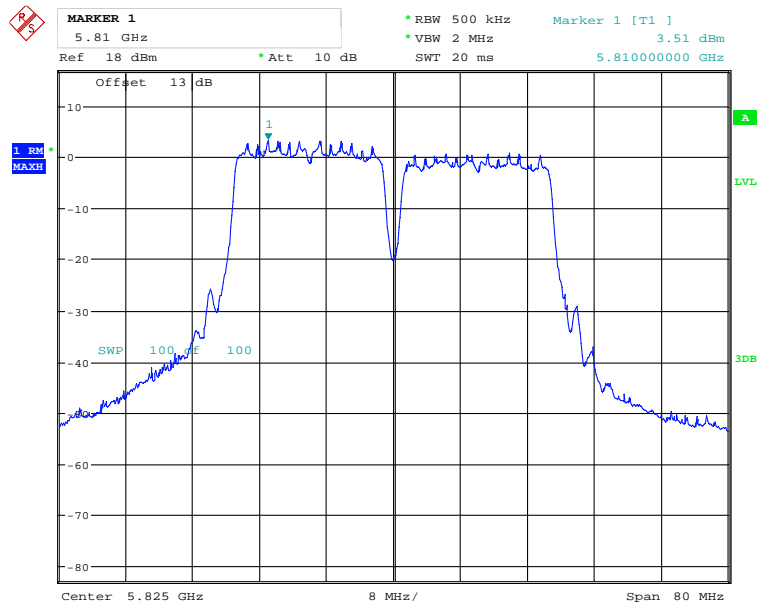

Date: 27.SEP.2015 17:57:02

Case 3

Low Channel-5745 MHz

Antenna 1

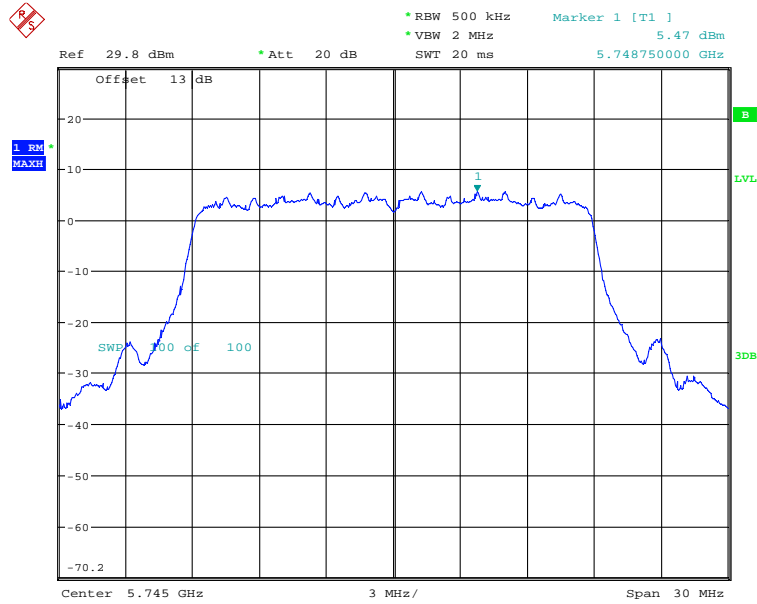

Date: 15.AUG.2015 20:24:40

Antenna 2

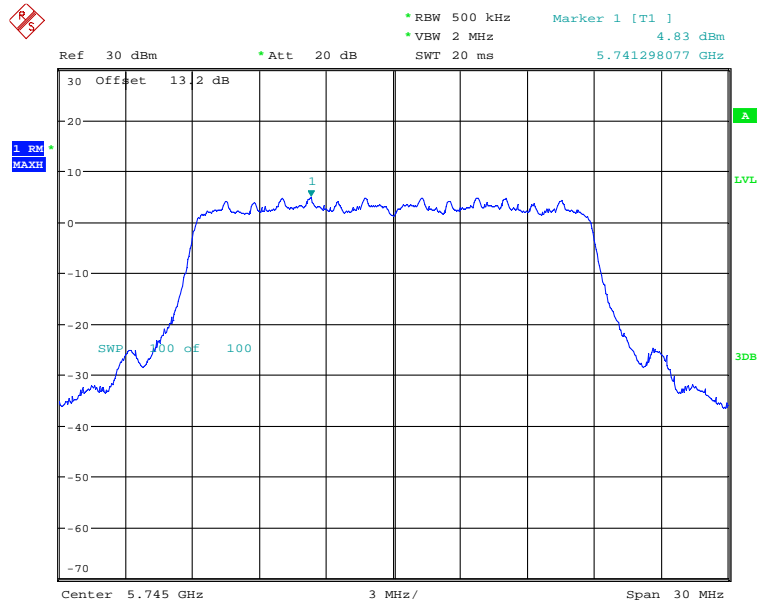

Date: 17.AUG.2015 23:16:19

Antenna 3

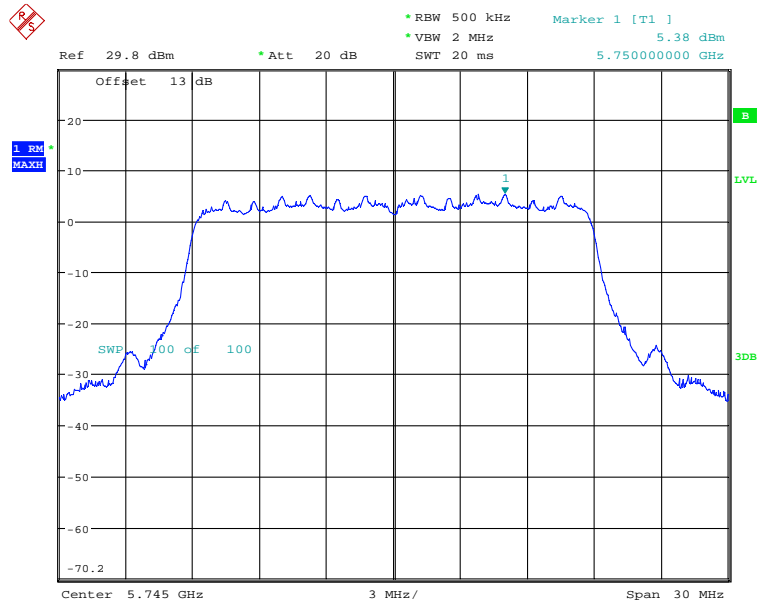

Date: 15.AUG.2015 20:25:37

Antenna 4

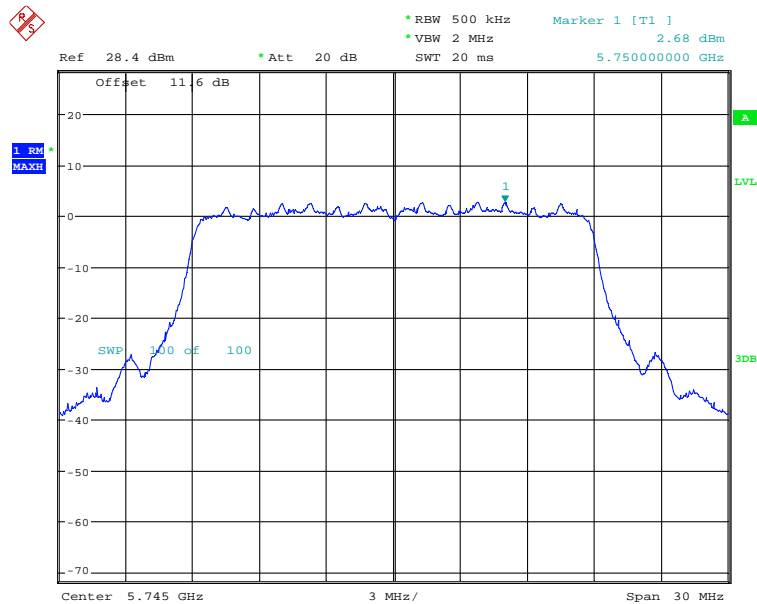

Date: 17.AUG.2015 23:26:41

Middle Channel-5785 MHz

Antenna 1

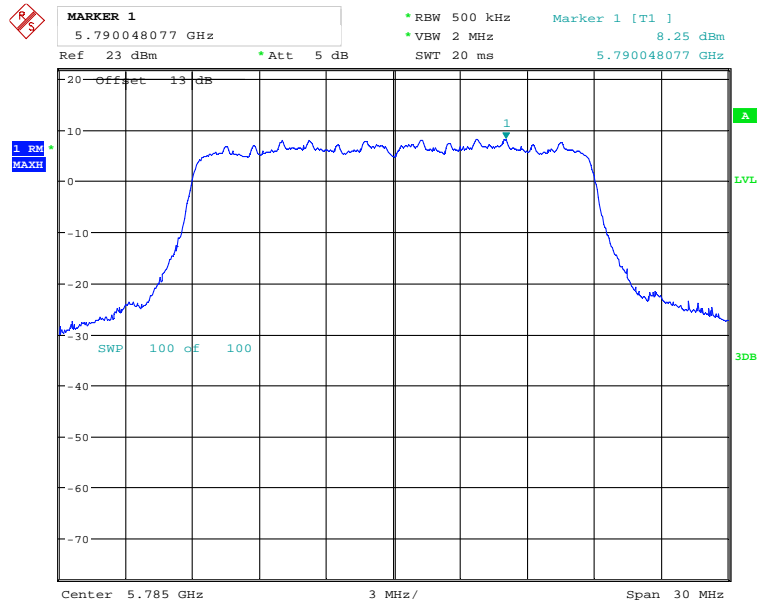

Date: 27.SEP.2015 12:33:09

Antenna 2

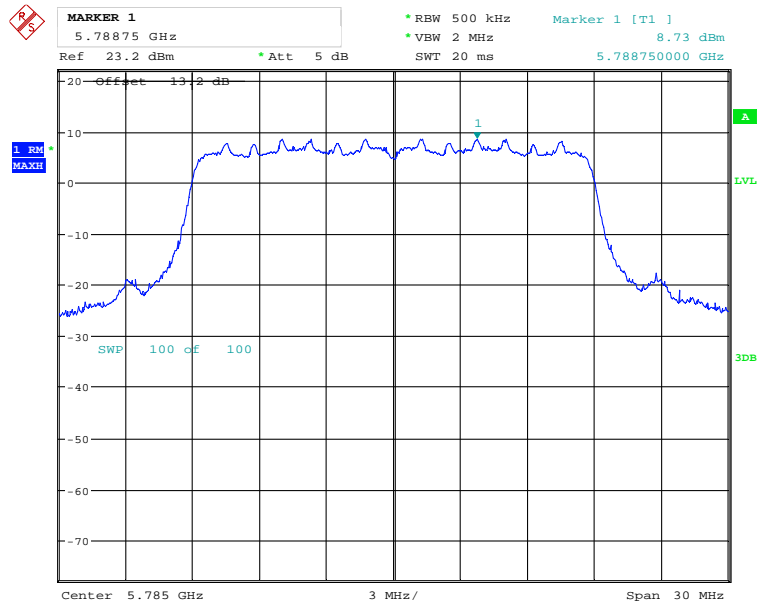

Date: 27.SEP.2015 12:34:39

Antenna 3

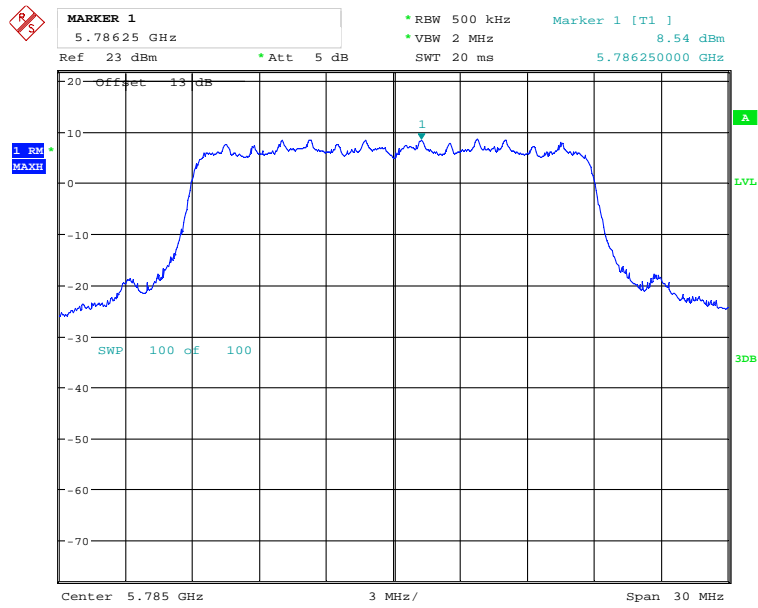

Date: 27.SEP.2015 12:35:31

Antenna 4

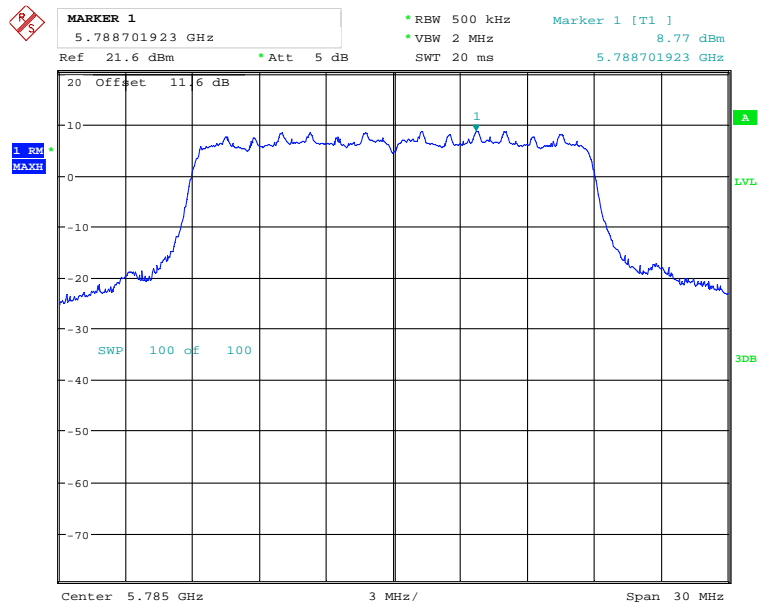

Date: 27.SEP.2015 12:36:12

High Channel-5835 MHz

Antenna 1

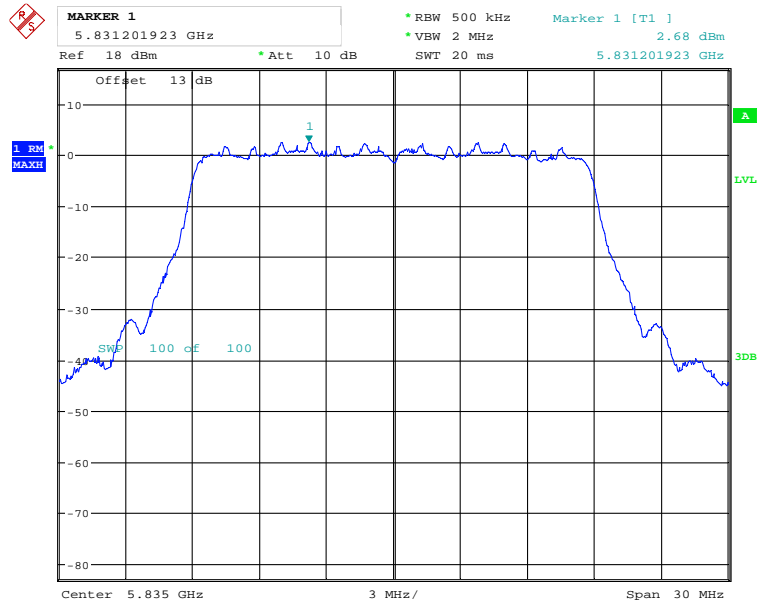

Date: 27.SEP.2015 14:48:42

Antenna 2

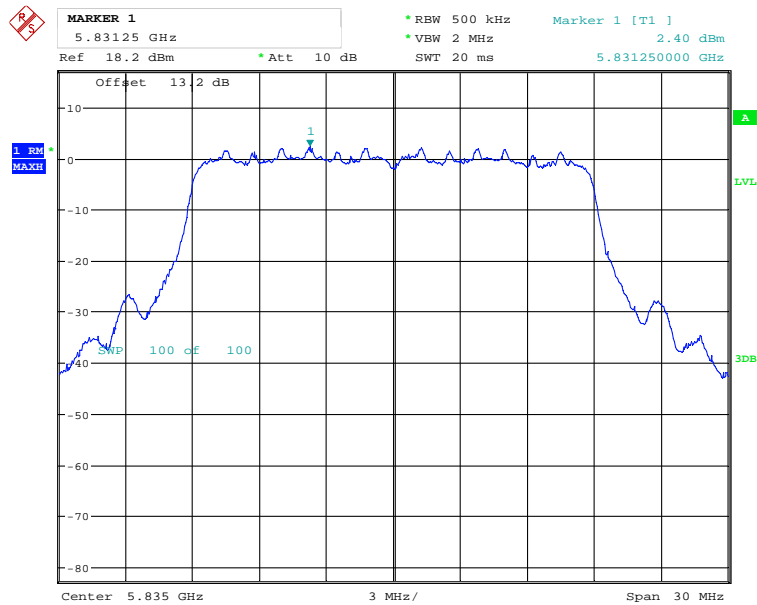

Date: 27.SEP.2015 14:50:50

Antenna 3

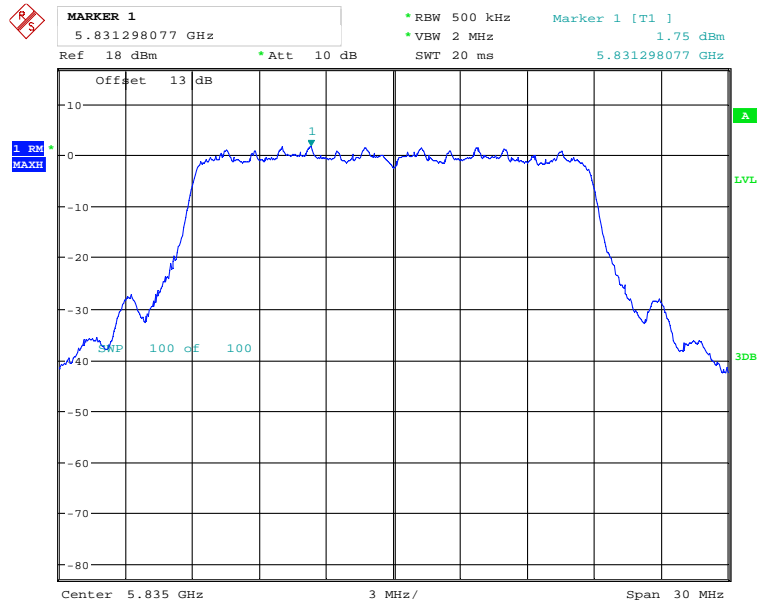

Date: 27.SEP.2015 14:51:31

Antenna 4

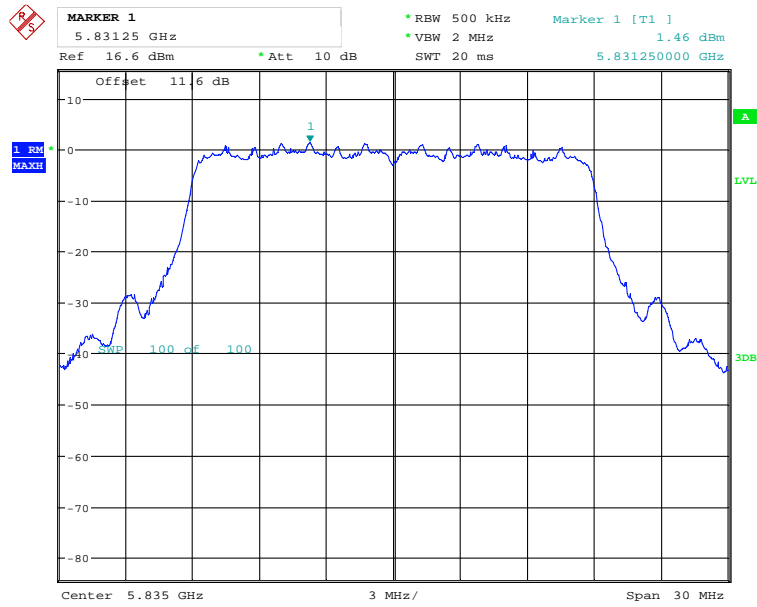

Date: 27.SEP.2015 14:52:13