



FCC PART 15C



IC RSS-210, ISSUE 8, DEC 2010  
TEST AND MEASUREMENT REPORT

For

**TruePath Wireless LLC**

2620 Augustine Drive, Suite # 260,  
Santa Clara, CA 95054, USA

**FCC ID: ZJ3-TPW2458-B-4AM**  
**IC: 9698A-TPW2458B4AM**

<b>Report Type:</b> Original Report	<b>Product Type:</b> Dual Band Wireless Access Point
<b>Test Engineers:</b> Jerry Huang	<i>Jerry Huang</i>
<b>Report Number:</b> R1104251-247	
<b>Report Date:</b> 2011-07-08	
<b>Reviewed By:</b> Victor Zhang EMC/RF Lead	<i>Victor Zhang</i>
<b>Prepared By:</b> (84) Bay Area Compliance Laboratories Corp. 1274 Anvilwood Avenue, Sunnyvale, CA 94089, USA Tel: (408) 732-9162 Fax: (408) 732-9164	

**Note:** This test report is prepared for the customer shown above and for the device described herein. It may not be duplicated or used in part without prior written consent from Bay Area Compliance Laboratories Corp. This report **must not** be used by the customer to claim product certification, approval, or endorsement by NVLAP\*, NIST, or any agency of the Federal Government.

\* This report may contain data that are not covered by the NVLAP accreditation and are marked with an asterisk "\*" ...

## TABLE OF CONTENTS

<b>1</b>	<b>GENERAL DESCRIPTION.....</b>	<b>6</b>
1.1	PRODUCT DESCRIPTION FOR EQUIPMENT UNDER TEST (EUT).....	6
1.2	MECHANICAL DESCRIPTION OF EUT .....	6
1.3	OBJECTIVE.....	6
1.4	RELATED SUBMITTAL(S)/GRANT(S) .....	6
1.5	TEST METHODOLOGY .....	6
1.6	MEASUREMENT UNCERTAINTY .....	7
1.7	TEST FACILITY .....	7
<b>2</b>	<b>SYSTEM TEST CONFIGURATION.....</b>	<b>8</b>
2.1	JUSTIFICATION.....	8
2.2	EUT EXERCISE SOFTWARE.....	8
2.3	EQUIPMENT MODIFICATIONS.....	8
2.4	SPECIAL ACCESSORIES .....	8
2.5	LOCAL SUPPORT EQUIPMENT .....	8
2.6	POWER SUPPLY.....	8
2.7	EUT INTERNAL CONFIGURATION .....	8
2.8	INTERFACE PORTS AND CABLING .....	9
<b>3</b>	<b>SUMMARY OF TEST RESULTS.....</b>	<b>10</b>
<b>4</b>	<b>FCC §15.247(I), §2.1091 &amp; IC RSS-102 - RF EXPOSURE INFORMATION.....</b>	<b>11</b>
4.1	APPLICABLE STANDARD.....	11
4.2	MPE PREDICTION.....	12
4.3	MPE RESULTS.....	12
<b>5</b>	<b>FCC §15.203 &amp; IC RSS-GEN §7.1.4 – ANTENNA REQUIREMENTS.....</b>	<b>14</b>
5.1	APPLICABLE STANDARD .....	14
5.2	ANTENNAS LIST.....	14
<b>6</b>	<b>FCC §15.207 &amp; RSS-GEN §7.2.2 – AC LINE CONDUCTED EMISSIONS .....</b>	<b>15</b>
6.1	APPLICABLE STANDARD.....	15
6.2	TEST SETUP .....	15
6.3	CORRECTED AMPLITUDE & MARGIN CALCULATION.....	15
6.4	TEST SETUP BLOCK DIAGRAM.....	16
6.5	TEST EQUIPMENT LIST AND DETAILS .....	16
6.6	TEST ENVIRONMENTAL CONDITIONS.....	16
6.7	SUMMARY OF TEST RESULTS.....	17
6.8	CONDUCTED EMISSIONS TEST PLOTS AND DATA .....	17
<b>7</b>	<b>FCC §15.247(D) &amp; IC RSS-210 §A8.5 - SPURIOUS EMISSIONS AT ANTENNA TERMINALS.....</b>	<b>22</b>
7.1	APPLICABLE STANDARD .....	22
7.2	MEASUREMENT PROCEDURE .....	22
7.3	TEST SETUP BLOCK DIAGRAM.....	22
7.4	TEST EQUIPMENT LIST AND DETAILS .....	22
7.5	TEST ENVIRONMENTAL CONDITIONS.....	23
7.6	TEST RESULTS .....	23
<b>8</b>	<b>FCC §15.205, §15.209, §15.247(D) &amp; IC RSS-210 §A8.5 – UNWANTED EMISSIONS.....</b>	<b>73</b>

8.1	APPLICABLE STANDARD .....	73
8.2	EUT AND TEST SETUP .....	74
8.3	TEST PROCEDURE .....	74
8.4	CORRECTED AMPLITUDE & MARGIN CALCULATION .....	74
8.5	TEST SETUP BLOCK DIAGRAM.....	75
8.6	TEST EQUIPMENT LIST AND DETAILS .....	75
8.7	TEST ENVIRONMENTAL CONDITIONS.....	76
8.8	SUMMARY OF TEST RESULTS.....	76
8.9	RADIATED EMISSIONS TEST RESULT DATA .....	77
<b>9</b>	<b>FCC §15.247(A)(2) &amp; IC RSS-210 §A8.2 – 6 DB &amp; 99% EMISSION BANDWIDTH.....</b>	<b>91</b>
9.1	APPLICABLE STANDARD .....	91
9.2	MEASUREMENT PROCEDURE .....	91
9.3	TEST SETUP BLOCK DIAGRAM.....	91
9.4	TEST EQUIPMENT LIST AND DETAILS .....	92
9.5	TEST ENVIRONMENTAL CONDITIONS.....	92
9.6	TEST RESULTS .....	92
<b>10</b>	<b>FCC §15.247(B) &amp; IC RSS-210 §A8.4 - PEAK OUTPUT POWER MEASUREMENT .....</b>	<b>113</b>
10.1	APPLICABLE STANDARD .....	113
10.2	MEASUREMENT PROCEDURE .....	113
10.3	TEST EQUIPMENT LIST AND DETAILS .....	113
10.4	TEST ENVIRONMENTAL CONDITIONS.....	114
10.5	TEST RESULTS .....	114
<b>11</b>	<b>FCC §15.247(D) &amp; IC RSS-210 §A8.5 - 100 KHZ BANDWIDTH OF BAND EDGES.....</b>	<b>146</b>
11.1	APPLICABLE STANDARD .....	146
11.2	MEASUREMENT PROCEDURE .....	146
11.3	TEST SETUP BLOCK DIAGRAM.....	146
11.4	TEST EQUIPMENT LIST AND DETAILS .....	147
11.5	TEST ENVIRONMENTAL CONDITIONS.....	147
<b>12</b>	<b>FCC §15.247(E) &amp; IC RSS-210 §A8.2(B) - POWER SPECTRAL DENSITY .....</b>	<b>168</b>
12.1	APPLICABLE STANDARD .....	168
12.2	MEASUREMENT PROCEDURE .....	168
12.3	TEST EQUIPMENT LIST AND DETAILS .....	168
12.4	TEST ENVIRONMENTAL CONDITIONS.....	168
12.5	TEST RESULTS .....	168
<b>13</b>	<b>IC RSS-GEN §4.10 &amp; §6 - RECEIVER SPURIOUS RADIATED EMISSIONS.....</b>	<b>194</b>
13.1	APPLICABLE STANDARD .....	194
13.2	EUT SETUP.....	194
13.3	TEST PROCEDURE .....	194
13.4	CORRECTED AMPLITUDE & MARGIN CALCULATION .....	195
13.5	TEST EQUIPMENT LISTS AND DETAILS .....	195
13.6	TEST ENVIRONMENTAL CONDITIONS.....	195
13.7	SUMMARY OF TEST RESULTS.....	196
13.8	RADIATED EMISSION TEST PLOTS AND DATA.....	197
<b>14</b>	<b>EXHIBIT A - FCC &amp; IC EQUIPMENT LABELING REQUIREMENTS.....</b>	<b>201</b>
14.1	FCC ID LABEL REQUIREMENTS .....	201
14.2	IC LABEL REQUIREMENTS .....	201
14.3	FCC ID & IC LABEL CONTENTS.....	202
14.4	FCC ID & IC LABEL LOCATION .....	202
<b>15</b>	<b>EXHIBIT B - TEST SETUP PHOTOGRAPHS .....</b>	<b>203</b>
15.1	AC LINE CONDUCTED EMISSIONS – FRONT VIEW .....	203

15.2	AC LINE CONDUCTED EMISSIONS – SIDE VIEW.....	203
15.3	RADIATED EMISSIONS BELOW 1 GHZ FRONT VIEW.....	204
15.4	RADIATED EMISSIONS BELOW 1 GHZ REAR VIEW.....	204
15.5	RADIATED EMISSIONS ABOVE 1 GHZ FRONT VIEW.....	205
15.6	RADIATED EMISSIONS BELOW 1 GHZ REAR VIEW.....	205
<b>16</b>	<b>EXHIBIT C - EUT PHOTOGRAPHS.....</b>	<b>206</b>
16.1	EUT – TOP VIEW.....	206
16.2	EUT-BOTTOM VIEW.....	206
16.3	EUT-PORT VIEW.....	207
16.4	EUT – 5.8 GHZ 12 DBI EXTERNAL ANTENNA VIEW.....	207
16.5	EUT – ADAPTER FOR POE.....	208
16.6	EUT – AC/DC POWER ADAPTER.....	208
16.7	EUT- COVER OFF VIEW 1.....	209
16.8	EUT- COVER OFF VIEW 2.....	209
16.9	EUT – INTERNAL COVER OFF VIEW 3.....	210
16.10	EUT – INTERNAL COVER OFF VIEW 4.....	210
16.11	EUT – INTERNAL COVER OFF VIEW 5.....	211
16.12	EUT – INTERNAL COVER OFF VIEW 6.....	211
16.13	EUT – 2.4 GHZ PATCH ANTENNA INTERNAL VIEW.....	212

**DOCUMENT REVISION HISTORY**

<b>Revision Number</b>	<b>Report Number</b>	<b>Description of Revision</b>	<b>Date of Revision</b>
0	R1104251-247	Original Report	2011-07-08

# 1 General Description

## 1.1 Product Description for Equipment under Test (EUT)

This test and measurement report was prepared on behalf of *TruePath Wireless, LLC* and their product FCC ID: ZJ3-TPW2458-B-4AM, IC: 9698A-TPW2458B4AM, Model: TPW2458-B-4A/M or the “EUT” as referred to in this report. The EUT is a 2.4/5.8 GHz dual bands wireless access point. Configuration is shown below:

Frequency Range (MHz)	EIRP Power Setting (dBm)	Modulation	Bandwidth (MHz)
2412~2462	+20, +30, +36	BPSK/QPSK/16QAM/64QAM	5, 20
5745~5825	+30, +36	BPSK/QPSK/16QAM/64QAM	5, 20

## 1.2 Mechanical Description of EUT

The “EUT” measures approximately 70cm (L) x 50cm (W) x 15 cm (H), and weighs approximately 15.3 kg.

*The test data gathered are from typical production sample, serial number 000065, provided by the manufacturer.*

## 1.3 Objective

This report is prepared on behalf of *TruePath Wireless LLC* in accordance with Part 2, Subpart J, and Part 15, Subparts B and C of the Federal Communication Commissions rules and IC RSS-210 Issue 8, Dec 2010.

The objective is to determine compliance with FCC/IC standards, rules and limits for this device including:

- RF Exposure
- Antenna Requirement
- Conducted Emissions
- Spurious Emissions at Antenna Port
- Radiated Spurious Emissions
- Restricted Band
- Receiver Spurious Emissions
- 6 dB Bandwidth & 99% Bandwidth
- Maximum Peak Output Power
- 100 kHz Bandwidth of Frequency Band Edge
- Power Spectral Density

## 1.4 Related Submittal(s)/Grant(s)

No Related Submittals.

## 1.5 Test Methodology

All measurements contained in this report were conducted in accordance with ANSI C63.4-2003, American National Standard for Methods of Measurement of Radio-Noise Emissions from Low-Voltage Electrical and Electronic Equipment in the range of 9 kHz to 40 GHz.

## 1.6 Measurement Uncertainty

All measurements involve certain levels of uncertainties, especially in field of EMC. The factors contributing to uncertainties are: spectrum analyzer, cable loss, antenna factor calibration, antenna directivity, antenna factor variation with height, antenna phase center variation, antenna factor frequency interpolation, measurement distance variation, site imperfections, mismatch (average), and system repeatability.

Based on NIS 81, The Treatment of Uncertainty in EMC Measurements, the values range from +2.0 for Conducted Emissions tests and +4.0 dB for Radiated Emissions tests are the most accurate estimates pertaining to uncertainty of EMC measurements at BACL.

Detailed instrumentation measurement uncertainties can be found in BACL report QAP-018. All radiated and conducted emissions measurement was performed at Bay Area Compliance Laboratory, Corp. The radiated testing was performed at an antenna-to-EUT distance of 3 meters.

## 1.7 Test Facility

The test site used by BACL Corp. to collect radiated and conducted emissions measurement data is located at its facility in Sunnyvale, California, USA.

The test sites at BACL have been fully described in reports submitted to the Federal Communication Commission (FCC) and Voluntary Control Council for Interference (VCCI). The details of these reports has been found to be in compliance with the requirements of Section 2.948 of the FCC Rules on February 11 and December 10, 1997, and Article 8 of the VCCI regulations on December 25, 1997. The facility also complies with the radiated and AC line conducted test site criteria set forth in ANSI C63.4-2003.

The Federal Communications Commission, Industry Canada, and Voluntary Control Council for Interference has the reports on file and is listed under FCC registration number: 90464, IC registration number: 3062A, and VCCI Registration Number: R-2463 and C-2698. The test site has been approved by the FCC, IC, and VCCI for public use and is listed in the FCC Public Access Link (PAL) database.

Additionally, BACL is a National Institute of Standards and Technology (NIST) accredited laboratory, under the National Voluntary Laboratory Accredited Program (Lab Code 200167-0). The current scope of accreditations can be found at <http://ts.nist.gov/Standards/scopes/2001670.htm>

## 2 System Test Configuration

### 2.1 Justification

The EUT was configured for testing according to ANSI C63.4-2003.

The EUT was tested in a testing mode to represent worst-case results during the final qualification test.

### 2.2 EUT Exercise Software

The Exercise Firm Ware Version was 1.0.0.223.2011.05.13.0148 with Engineering TX Utility tx\_ofdm\_wb (md5sum = d9a038f79a6e6893d9a652914743d952).

### 2.3 Equipment Modifications

No modifications were made to the EUT.

### 2.4 Special Accessories

N/A

### 2.5 Local Support Equipment

Manufacturer	Description	Model No.	Serial No.
Toshiba	Laptop	-	-

### 2.6 Power Supply

Manufacturer	Description	Model No.	Serial No.
TruePath Wireless	PoE Adaptor	TPW-PS-001US	000078

### 2.7 EUT Internal Configuration

Manufacturer	Description	Model No.	Serial No.
TruePath Wireless	Jumper Board	-	108-15042-001
TruePath Wireless	STACK Module	-	B22
TruePath Wireless	XCVR Module	-	C23
TruePath Wireless	CPU	-	C28
TruePath Wireless	FPGA	-	C28



## 2.8 Interface Ports and Cabling

<b>Cable Description</b>	<b>Length (m)</b>	<b>From</b>	<b>To</b>
Ethernet cable	< 10m	EUT	Laptop
Ethernet cable	< 10m	EUT	PoE

### 3 Summary of Test Results

Results reported relate only to the product tested.

FCC & IC Rules	Description of Test	Results
FCC §15.247(i), §2.1091 IC RSS-102	RF Exposure Information	Compliant
FCC §15.203 IC RSS-Gen §7.1.4	Antenna Requirement	Compliant
FCC §15.207(a) IC RSS-Gen §7.2.2	AC Line Conducted Emissions	Compliant
FCC §15.247(d) IC RSS-210 §2.6	Spurious Emissions at Antenna Port	Compliant
FCC §15.205 IC RSS-210 §2.2	Restricted Bands	Compliant
FCC §15.209, §15.247 IC RSS-210 §2.6	Radiated Spurious Emissions	Compliant
FCC §15.247(a)(2) IC RSS-210 §A8.2	6 dB Emission Bandwidth	Compliant
FCC §15.247(b)(3) IC RSS-210 §A8.4	Maximum Peak Output Power	Compliant
FCC §15.247(d) IC RSS-210 §A8.5	Band Edge	Compliant
FCC §15.247(e) IC RSS-210 §A8.2 (b)	Power Spectral Density	Compliant
IC RSS-Gen §4.10, §6	Receiver Spurious Emission	Compliant

## 4 FCC §15.247(i), §2.1091 & IC RSS-102 - RF Exposure Information

### 4.1 Applicable Standard

According to FCC §15.247(i) and §1.1307(b)(1), systems operating under the provisions of this section shall be operated in a manner that ensures that the public is not exposed to radio frequency energy level in excess of the Commission's guidelines.

#### Limits for General Population/Uncontrolled Exposure

Frequency Range (MHz)	Electric Field Strength (V/m)	Magnetic Field Strength (A/m)	Power Density (mW/cm <sup>2</sup> )	Averaging Time (minutes)
Limits for General Population/Uncontrolled Exposure				
0.3-1.34	614	1.63	*(100)	30
1.34-30	824/f	2.19/f	*(180/f <sup>2</sup> )	30
30-300	27.5	0.073	0.2	30
300-1500	/	/	f/1500	30
1500-100,000	/	/	1.0	30

f = frequency in MHz

\* = Plane-wave equivalent power density

Before equipment certification is granted, the procedure of IC RSS-102 must be followed concerning the exposure of humans to RF fields.

According to RSS-102 Issue 4 section 4.2, RF limits used for general public will be applied to the EUT.

Frequency Range (MHz)	Electric Field (V/m rms)	Magnetic Field (A/m rms)	Power Density (W/m <sup>2</sup> )	Time Averaging (min)
0.003 - 1	280	2.19	-	6
1 - 10	280 / f	2.19 / f	-	6
10 - 30	28	2.19 / f	-	6
30 - 300	28	0.073	2*	6
300 - 1 500	1.585 f <sup>0.5</sup>	0.0042 f <sup>0.5</sup>	f / 150	6
1 500 - 15 000	61.4	0.163	10	6
15 000 - 150 000	61.4	0.163	10	616000 / f <sup>1.2</sup>
150 000- 300 000	0.158 f <sup>0.5</sup>	4.21 x 10 <sup>-4</sup> f <sup>0.5</sup>	6.67 x 10 <sup>-5</sup> f	616000 / f <sup>1.2</sup>

**Note:** f is frequency in MHz

\* Power density limit is applicable at frequencies greater than 100 MHz

## 4.2 MPE Prediction

Predication of MPE limit at a given distance, Equation from OET Bulletin 65, Edition 97-01

$$S = PG/4\pi R^2$$

Where: S = power density

P = power input to antenna

G = power gain of the antenna in the direction of interest relative to an isotropic radiator

R = distance to the center of radiation of the antenna

## 4.3 MPE Results

2.4 GHz Band, Worst case Legacy mode 4 correlated signal with 14.48 dBm output, and the direction antenna gain is 14 dBi + 10\*Log (4) dBi = 20 dBi, so the MPE result will be:

Maximum peak output power at antenna input terminal (dBm):	14.48
Maximum peak output power at antenna input terminal (mW):	28.05
Prediction distance (cm):	20
Prediction frequency (MHz):	2412
Maximum Antenna Gain, typical (dBi):	20
Maximum Antenna Gain (numeric):	100
Power density of prediction frequency at 20.0 cm (mW/cm <sup>2</sup> , W/m <sup>2</sup> ):	0.5580/5.580
MPE limit for uncontrolled exposure at prediction frequency (mW/cm <sup>2</sup> , W/m <sup>2</sup> ):	1.0/10

2.4 GHz Band, Worst case 4xMIMO with 21.5 dBm output, and the direction antenna gain is 14 dBi + 10\*Log (4/4) dBi = 14 dBi, so the MPE result will be:

Maximum peak output power at antenna input terminal (dBm):	21.50
Maximum peak output power at antenna input terminal (mW):	141.25
Prediction distance (cm):	20
Prediction frequency (MHz):	2412
Maximum Antenna Gain, typical (dBi):	14
Maximum Antenna Gain (numeric):	25.12
Power density of prediction frequency at 20.0 cm (mW/cm <sup>2</sup> , W/m <sup>2</sup> ):	0.7059/7.059
MPE limit for uncontrolled exposure at prediction frequency (mW/cm <sup>2</sup> , W/m <sup>2</sup> ):	1.0/10

5.8 GHz Band, Worst case Legacy mode 4 correlated signal with 16.41 dBm output, and the direction antenna gain is  $12 \text{ dBi} + 10 \cdot \log(4) \text{ dBi} = 18 \text{ dBi}$ , so the MPE result will be:

Maximum peak output power at antenna input terminal (dBm):	16.41
Maximum peak output power at antenna input terminal (mW):	43.75
Prediction distance (cm):	20
Prediction frequency (MHz):	5725
Maximum Antenna Gain, typical (dBi):	18
Maximum Antenna Gain (numeric):	63.10
Power density of prediction frequency at 20.0 cm ( $\text{mW}/\text{cm}^2$ , $\text{W}/\text{m}^2$ ):	0.5492/5.492
MPE limit for uncontrolled exposure at prediction frequency ( $\text{mW}/\text{cm}^2$ , $\text{W}/\text{m}^2$ ):	1.0/10

5.8 GHz Band, Worst case 4xMIMO with 22.17 dBm output, and the direction antenna gain is  $12 \text{ dBi} + 10 \cdot \log(4/4) \text{ dBi} = 12 \text{ dBi}$ , so the MPE result will be:

Maximum peak output power at antenna input terminal (dBm):	22.17
Maximum peak output power at antenna input terminal (mW):	164.82
Prediction distance (cm):	20
Prediction frequency (MHz):	5725
Maximum Antenna Gain, typical (dBi):	12
Maximum Antenna Gain (numeric):	15.85
Power density of prediction frequency at 20.0 cm ( $\text{mW}/\text{cm}^2$ , $\text{W}/\text{m}^2$ ):	0.5197/5.197
MPE limit for uncontrolled exposure at prediction frequency ( $\text{mW}/\text{cm}^2$ , $\text{W}/\text{m}^2$ ):	1.0/10

The device is compliant with the requirement MPE limit for uncontrolled exposure.

## 5 FCC §15.203 & IC RSS-Gen §7.1.4 – Antenna Requirements

### 5.1 Applicable Standard

According to FCC §15.203, an intentional radiator shall be designed to ensure that no antenna other than that furnished by the responsible party shall be used with the device. The use of a permanently attached antenna or of an antenna that uses a unique coupling to the intentional radiator shall be considered sufficient to comply with the provisions of this Section. The manufacturer may design the unit so that a broken antenna can be replaced by the user, but the use of a standard antenna jack or electrical connector is prohibited.

And according to FCC §15.247 (b)(4), if transmitting antennas of directional gain greater than 6 dBi are used the power shall be reduced by the amount in dB that the directional gain of the antenna exceeds 6 dBi.

As per IC RSS-Gen §7.1.4: Transmitter Antenna

A transmitter can only be sold or operated with antennas with which it was certified. A transmitter may be certified with multiple antenna types. An antenna type comprises antennas having similar in-band and out-of-band radiation patterns. Testing shall be performed using the highest-gain antenna of each combination of transmitter and antenna type for which certification is being sought, with the transmitter output power set at the maximum level. Any antenna of the same type and having equal or lesser gain as an antenna that had been successfully tested for certification with the transmitter, will also be considered certified with the transmitter, and may be used and marketed with the transmitter. The manufacturer shall include with the application for certification a list of acceptable antenna types to be used with the transmitter.

When a measurement at the antenna connector is used to determine RF output power, the effective gain of the device's antenna shall be stated, based on measurement or on data from the antenna manufacturer. Any antenna gain in excess of 6 dBi (6 dB above isotropic gain) shall be added to the measured RF output power before using the power limits specified in RSS-210 or RSS-310 for devices of RF output powers of 10 milliwatts or less. For devices of output powers greater than 10 milliwatts, except devices subject to RSS-210 Annex 8 (Frequency Hopping and Digital Modulation Systems Operating in the 902-928 MHz, 2400-2483.5 MHz, and 5725-5850 MHz Bands) or RSS-210 Annex 9 (Local Area Network Devices), the total antenna gain shall be added to the measured RF output power before using the specified power limits. For devices subject to RSS-210 Annex 8 or Annex 9, the antenna gain shall not be added.

### 5.2 Antennas List

The device has two antennas; the antennas are installed by the licensed professionals.

Frequency Band	Antenna Gain (dBi)
2.4 GHz	14 (Internal)
5.8 GHz	12 (External)

## 6 FCC §15.207 & RSS-Gen §7.2.2 – AC Line Conducted Emissions

### 6.1 Applicable Standard

As per FCC §15.207 & RSS-Gen §7.2.2 AC Power Line Conducted Emissions limits:

For an intentional radiator that is designed to be connected to the public utility (AC) power line, the radio frequency voltage that is conducted back onto the AC power line on any frequency or frequencies within the band 150 kHz to 30 MHz shall not exceed the limits in the following table, as measured using a 50  $\mu$ H/50 ohms line impedance stabilization network (LISN). Compliance with the provisions of this paragraph shall be based on the measurement of the radio frequency voltage between each power line and ground at the power terminal. The lower limit applies at the boundary between the frequencies ranges.

Frequency of Emission (MHz)	Conducted Limit (dBuV)	
	Quasi-peak	Average
0.15-0.5	66 to 56 *	56 to 46 *
0.5-5	56	46
5-30	60	50

\* Decreases with the logarithm of the frequency.

### 6.2 Test Setup

The measurement was performed at shield room, using the setup per ANSI C63.4-2003 measurement procedure. The specification used was FCC and IC limits.

External I/O cables were draped along the edge of the test table and bundle when necessary.

The AC/DC power adapter of the EUT was connected with LISN-1 which provided 120 V / 60 Hz AC power.

### 6.3 Corrected Amplitude & Margin Calculation

The Corrected Amplitude is calculated by adding the Cable Loss, and Attenuator Factor adding to the Indicated Reading. The basic equation is as follows:

$$\text{Corrected Amplitude} = \text{Indicated Reading} + \text{Cable Loss} + \text{Attenuator Factor}$$

For example, a Corrected Amplitude of 34.08 dBuV/m = Indicated Reading (23.85 dBuV) + Cable Factor (0.22 dB) + Attenuator Factor (10dB)

The “**Margin**” column of the following data tables indicates the degree of compliance within the applicable limit. For example, a margin of -7 dB means the emission is 7 dB below the maximum limit. The equation for margin calculation is as follows:

$$\text{Margin} = \text{Corrected Amplitude} - \text{Limit}$$

### 6.4 Test Setup Block Diagram

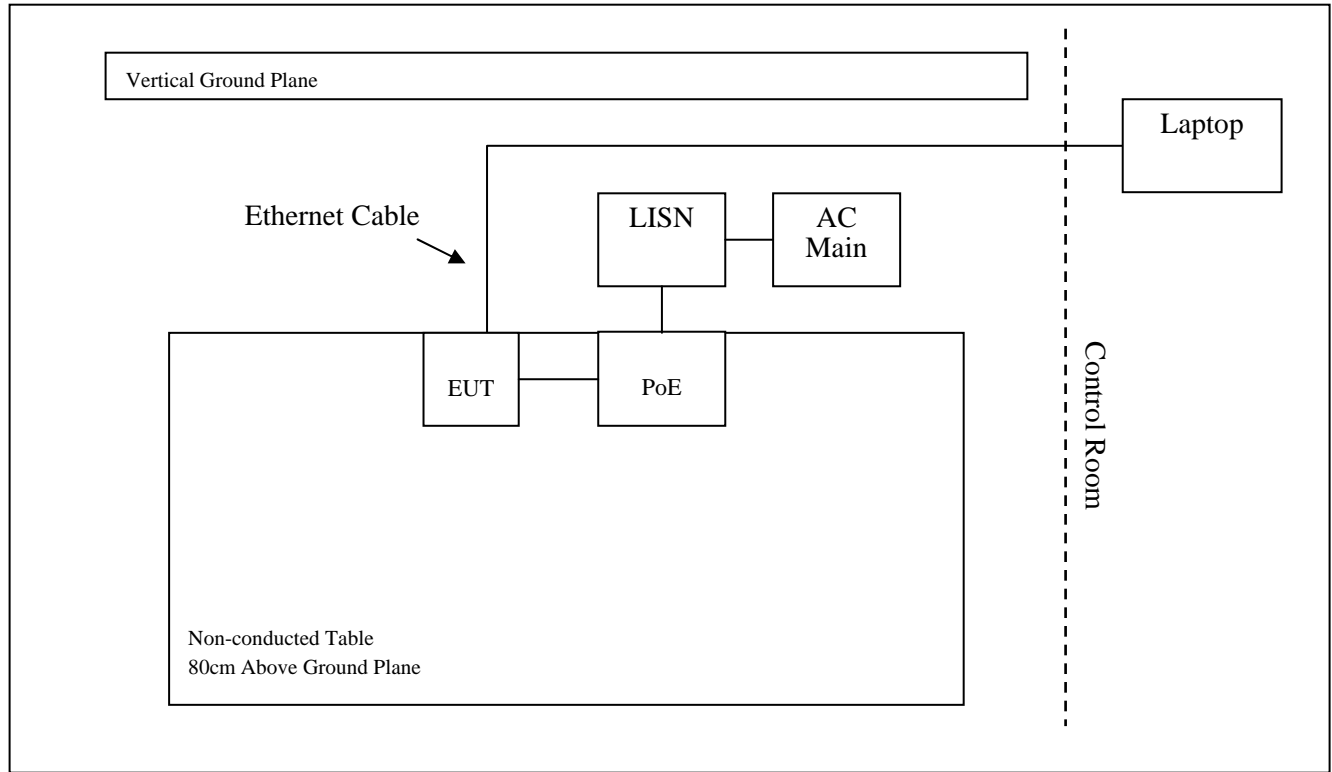

### 6.5 Test Equipment List and Details

Manufacturers	Descriptions	Models	Serial Numbers	Calibration Dates
Solar Electronics	LISN	9252-50-R-24-N	511213	2010-06-28
Rohde & Schwarz	EMI Test Receiver	ESCI 1166.595 0K03	10037	2011-03-24

**Statement of Traceability:** **BACL Corp.** attests that all calibrations have been performed according to NVLAP requirements, traceable to the NIST.

### 6.6 Test Environmental Conditions

<b>Temperature:</b>	16~23° C
<b>Relative Humidity:</b>	35~63%
<b>ATM Pressure:</b>	101.2~103.5kPa

Testing was performed by Jerry Huang on 2011-05-06 in 5 meter chamber 3.



## 6.7 Summary of Test Results

According to the recorded data, the EUT complied with FCC Part 15C and IC RSS-Gen limits, and had the worst margin reading of:

<b>2.4 GHz Band, Transmitting</b>			
<b>Margin (dB)</b>	<b>Frequency (MHz)</b>	<b>Conductor (Line/Neutral)</b>	<b>Test Range</b>
-2.24	12.80907	Neutral	0.15-30 MHz

<b>5.8 GHz Band, Transmitting</b>			
<b>Margin (dB)</b>	<b>Frequency (MHz)</b>	<b>Conductor (Line/Neutral)</b>	<b>Test Range</b>
-2.90	12.7476	Neutral	0.15-30 MHz

*Please refer to the following plots and tables for detailed results.*

## 6.8 Conducted Emissions Test Plots and Data

Please refer to the following tables and plots.

**2.4 GHz, EIRP +36 dBm, 20 MHz Bandwidth – 2437 MHz**

**120 V, 60 Hz – Line**

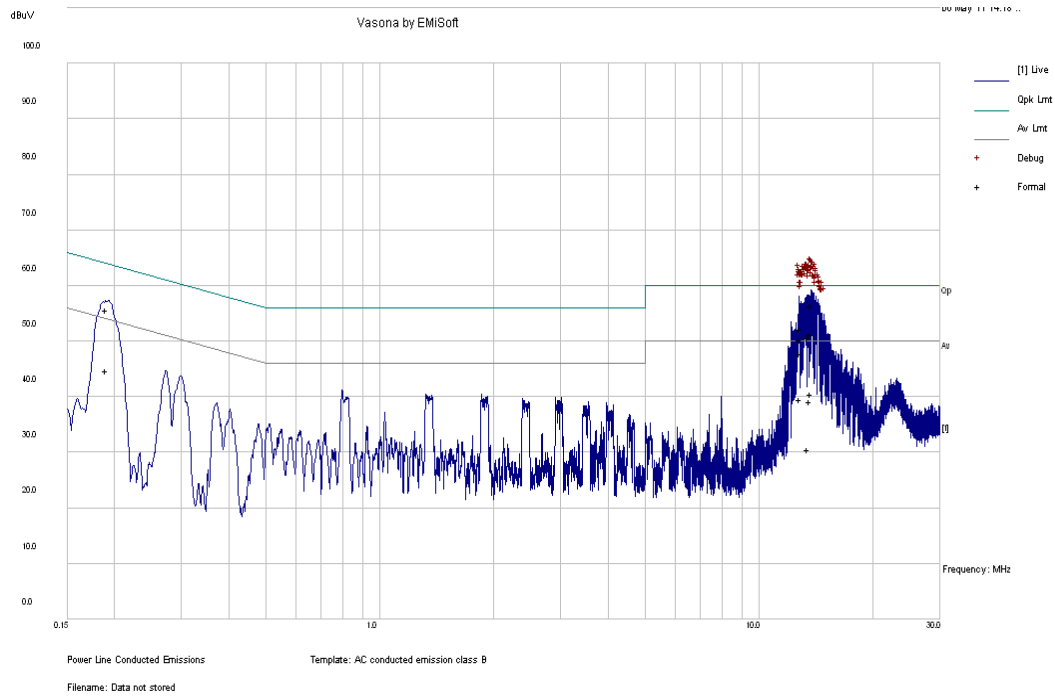

**Quasi-Peak Measurement:**

Frequency (MHz)	Corrected Amplitude (dBuV)	Measurement Type	Conductor (L/N)	Limit (dBuV)	Margin (dB)
13.733	56.63	Quasi Peak	L	60	-3.37
13.79374	52.63	Quasi Peak	L	60	-7.37
12.74871	51.09	Quasi Peak	L	60	-8.91
13.90284	51.08	Quasi Peak	L	60	-8.92
13.30276	51.08	Quasi Peak	L	60	-8.92
13.9631	50.34	Quasi Peak	L	60	-9.66

**Average Measurement:**

Frequency (MHz)	Corrected Amplitude (dBuV)	Measurement Type	Conductor (L/N)	Limit (dBuV)	Margin (dB)
12.74871	47.1	Average	L	50	-2.90
13.733	39.77	Average	L	50	-10.23
13.79374	32.55	Average	L	50	-17.45
13.90284	32.35	Average	L	50	-17.65
13.30276	31.41	Average	L	50	-18.59
13.9631	31.05	Average	L	50	-18.95

**120 V, 60 Hz – Neutral**

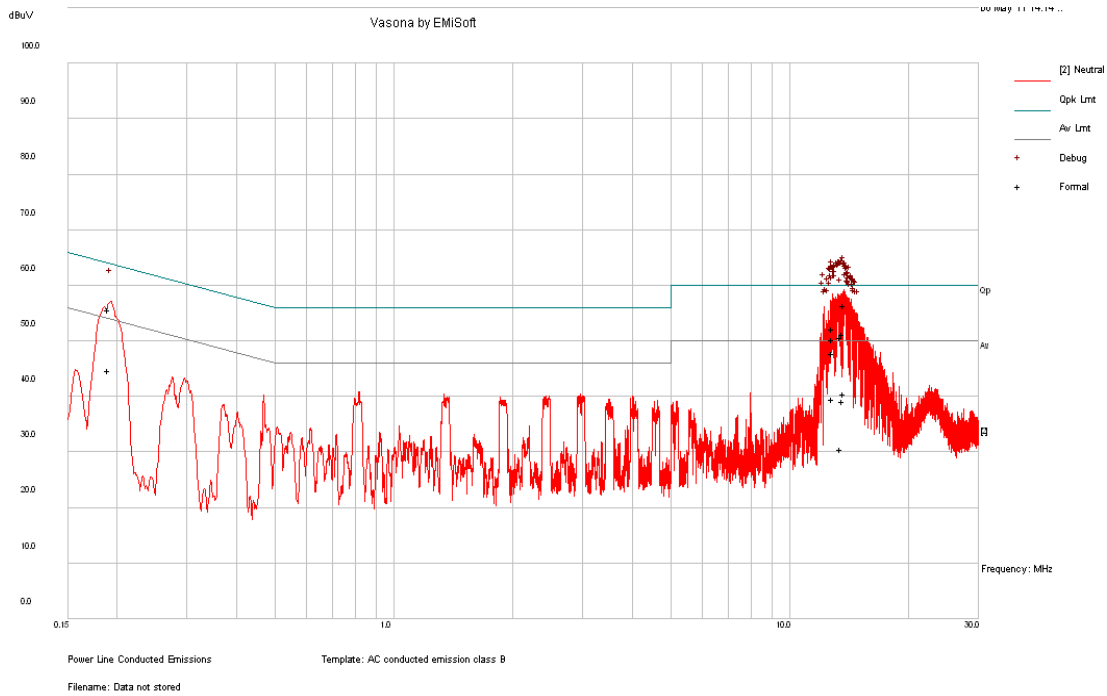

**Quasi-Peak Measurement:**

Frequency (MHz)	Corrected Amplitude (dBuV)	Measurement Type	Conductor (L/N)	Limit (dBuV)	Margin (dB)
13.72811	56.35	Quasi Peak	N	60	-3.65
12.80907	52.21	Quasi Peak	N	60	-7.79
0.190668	55.63	Quasi Peak	N	64.01	-8.38
13.60384	51.26	Quasi Peak	N	60	-8.74
13.50297	50.68	Quasi Peak	N	60	-9.32
12.87196	50.23	Quasi Peak	N	60	-9.77

**Average Measurement:**

Frequency (MHz)	Corrected Amplitude (dBuV)	Measurement Type	Conductor (L/N)	Limit (dBuV)	Margin (dB)
12.80907	47.76	Average	N	50	-2.24
0.190668	44.65	Average	N	54.01	-9.36
13.72811	40.46	Average	N	50	-9.54
12.87196	39.65	Average	N	50	-10.35
13.60384	39.25	Average	N	50	-10.75
13.50297	30.64	Average	N	50	-19.36

**5.8 GHz Band, EIRP +36 dBm, 20 MHz Bandwidth – 5785 MHz**

**120 V, 60 Hz – Line**

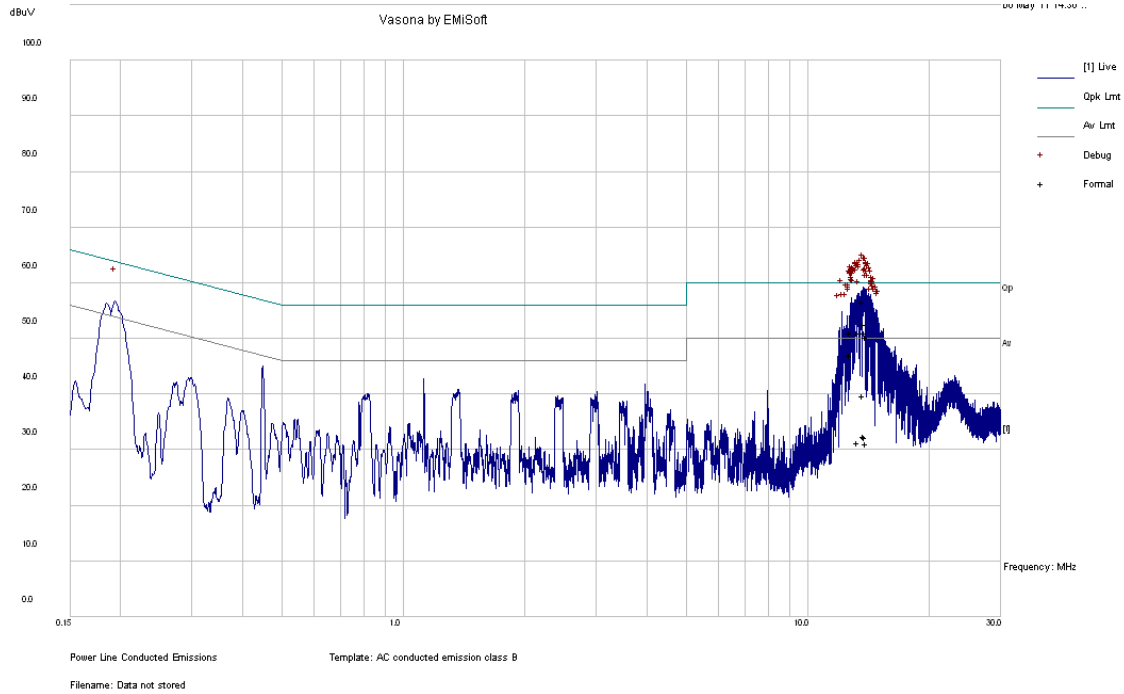

**Quasi-Peak Measurement:**

Frequency (MHz)	Corrected Amplitude (dBuV)	Measurement Type	Conductor (L/N)	Limit (dBuV)	Margin (dB)
13.71884	56.46	Quasi Peak	L	60	-3.54
13.95907	50.44	Quasi Peak	L	60	-9.56
13.93717	50.82	Quasi Peak	L	60	-9.18
13.54335	50.82	Quasi Peak	L	60	-9.18
12.7476	50.84	Quasi Peak	L	60	-9.16
0.190845	55.85	Quasi Peak	L	64	-8.15

**Average Measurement:**

Frequency (MHz)	Corrected Amplitude (dBuV)	Measurement Type	Conductor (L/N)	Limit (dBuV)	Margin (dB)
12.7476	47.1	Average	L	50	-2.90
0.190845	44.68	Average	L	54	-9.32
13.71884	40.34	Average	L	50	-9.66
13.93717	32.95	Average	L	50	-17.05
13.54335	32.92	Average	L	50	-17.08
13.95907	30.5	Average	L	50	-19.50

**120 V, 60 Hz – Neutral**

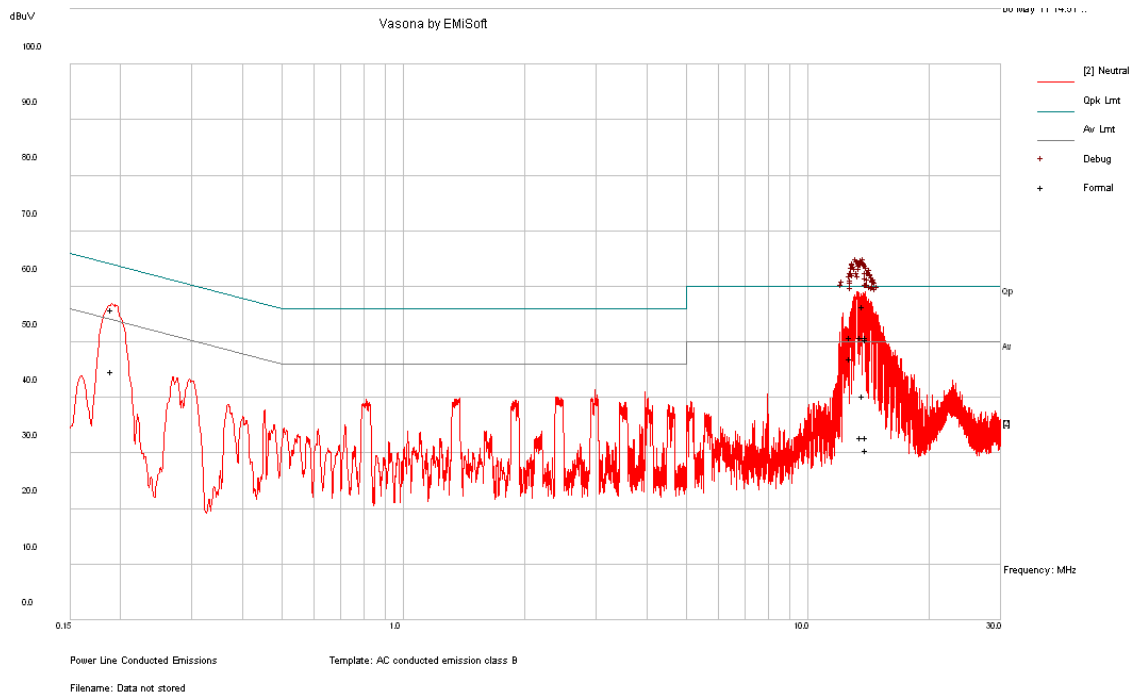

**Quasi-Peak Measurement:**

Frequency (MHz)	Corrected Amplitude (dBuV)	Measurement Type	Conductor (L/N)	Limit (dBuV)	Margin (dB)
13.21289	54.39	Quasi Peak	N	60	-5.61
13.6617	51.64	Quasi Peak	N	60	-8.36
13.84274	51.3	Quasi Peak	N	60	-8.70
13.34951	51.24	Quasi Peak	N	60	-8.76
13.11681	51.02	Quasi Peak	N	60	-8.98
12.98344	49.62	Quasi Peak	N	60	-10.38

**Average Measurement:**

Frequency (MHz)	Corrected Amplitude (dBuV)	Measurement Type	Conductor (L/N)	Limit (dBuV)	Margin (dB)
13.6617	36.58	Average	N	50	-13.42
13.11681	35.75	Average	N	50	-14.25
13.21289	35.29	Average	N	50	-14.71
13.34951	31.42	Average	N	50	-18.58
13.84274	30.59	Average	N	50	-19.41
12.98344	29.55	Average	N	50	-20.45

## 7 FCC §15.247(d) & IC RSS-210 §A8.5 - Spurious Emissions at Antenna Terminals

### 7.1 Applicable Standard

For FCC §15.247(d) and IC RSS-210 § A8.5 in any 100 kHz bandwidth outside the frequency band in which the spread spectrum or digitally modulated intentional radiator is operating, the radio frequency power that is produced by the intentional radiator shall be at least 20 dB below that in the 100 kHz bandwidth within the band that contains the highest level of the desired power, based on either an RF conducted or a radiated measurement, provided the transmitter demonstrates compliance with the peak conducted power limits.

### 7.2 Measurement Procedure

The RF output of the EUT was connected to a spectrum analyzer through appropriate attenuation. The resolution bandwidth of the spectrum analyzer was set at 100 kHz. Sufficient scans were taken to show any out of band emissions up to 10th harmonic.

### 7.3 Test Setup Block Diagram

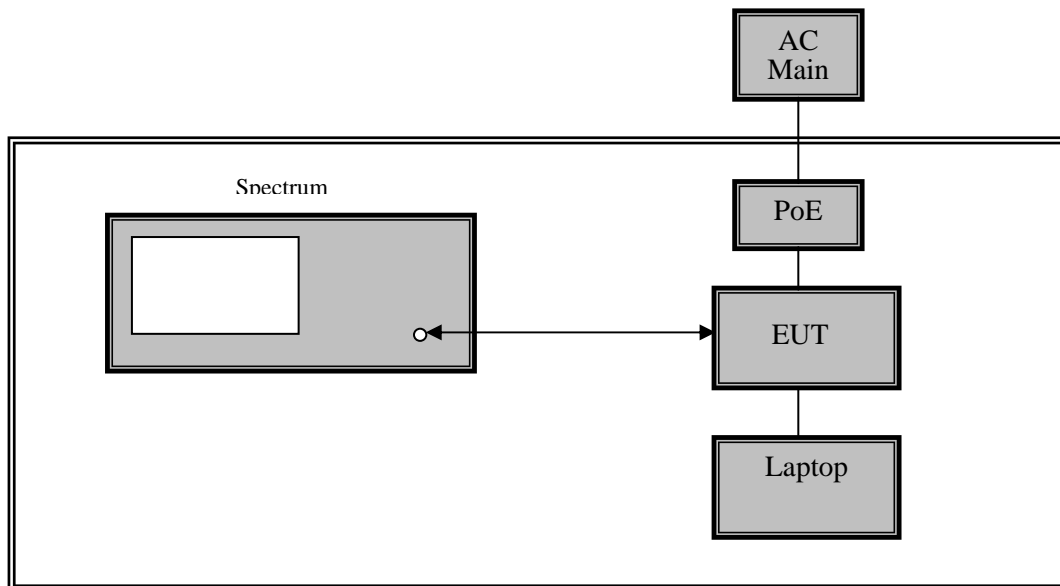

### 7.4 Test Equipment List and Details

Manufacturers	Descriptions	Models	Serial Numbers	Calibration Dates
Agilent	Analyzer, Spectrum	E4446A	US44300386	2010-08-18

**Statement of Traceability:** **BACL Corp.** attests that all calibrations have been performed according to NVLAP requirements, traceable to the NIST.

### 7.5 Test Environmental Conditions

<b>Temperature:</b>	16~23° C
<b>Relative Humidity:</b>	35~40%
<b>ATM Pressure:</b>	101.2~103.5kPa

Testing was performed by Jerry Huang on 2011-05-05 to 2011-05-13 in RF site.

### 7.6 Test Results

All the results are represent the worse case of EUT working mode; please refer to following plots of spurious emissions.

#### 2.4 GHz Band (2412–2462 MHz): BPSK with 5 MHz bandwidth, EIRP +36 dBm

#### 2.4 GHz, Antenna #1:

Low Channel

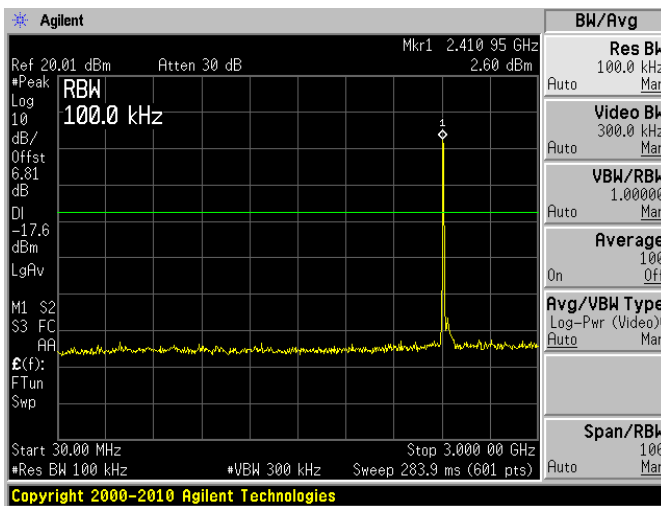

Low Channel

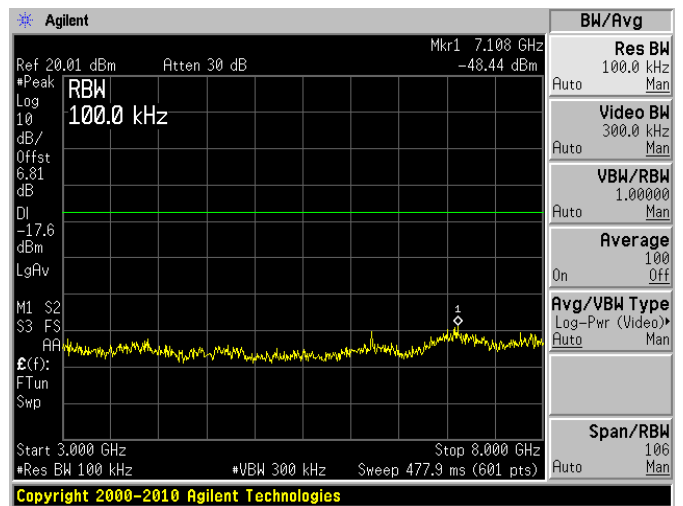

Low Channel

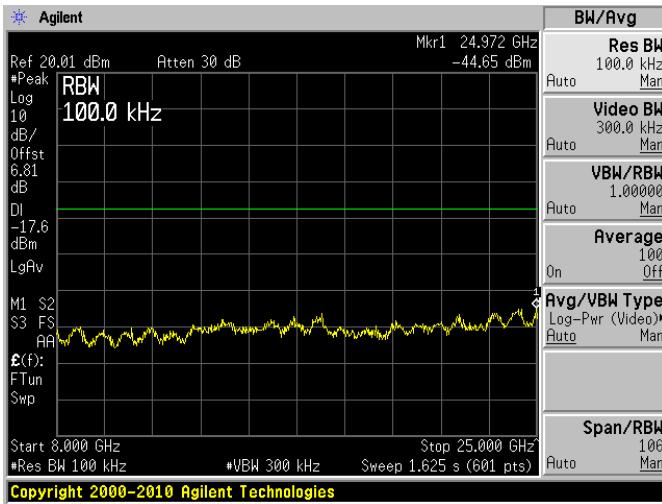

Middle Channel

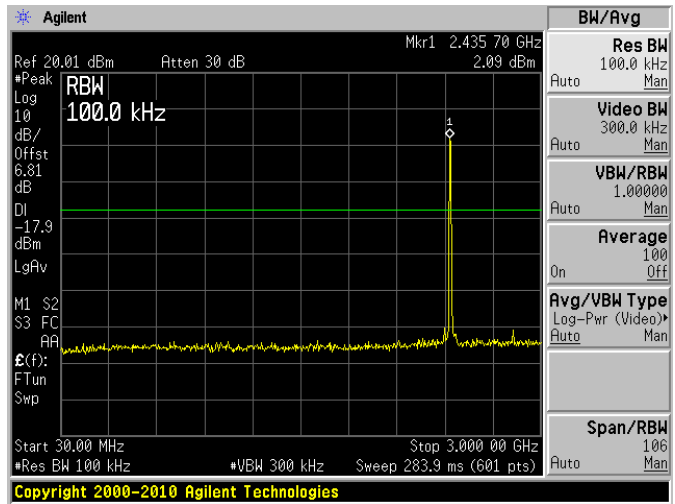

Middle Channel

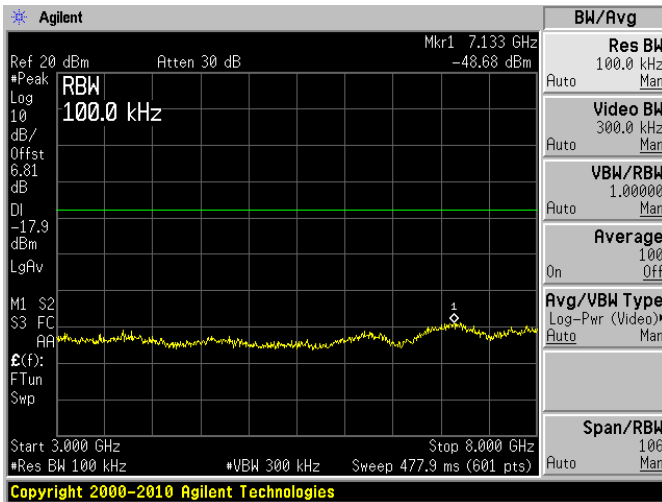

Middle Channel

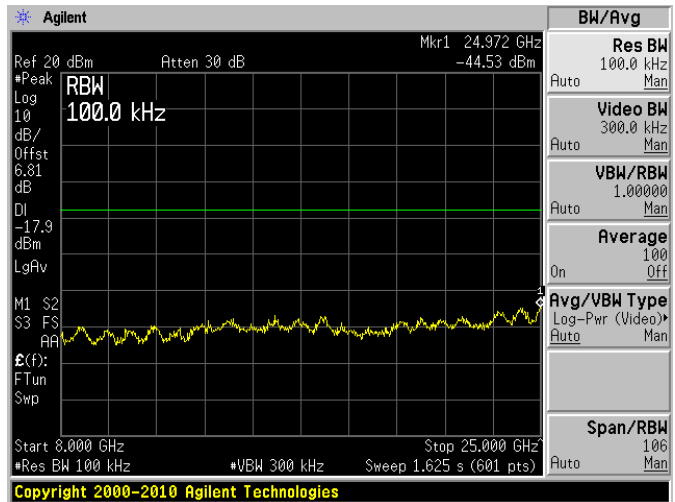

High Channel

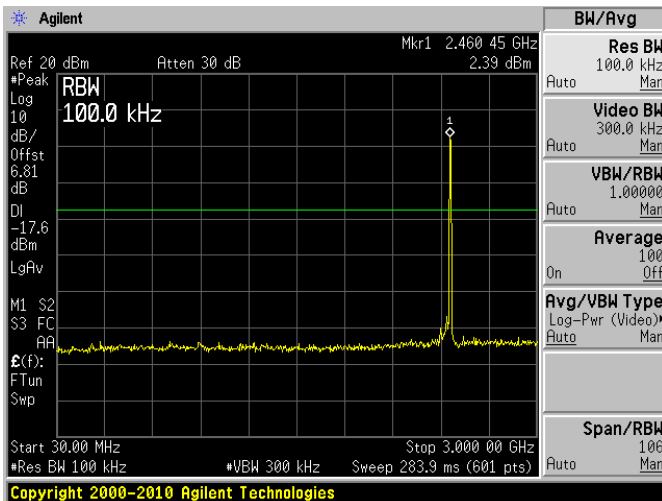

High Channel

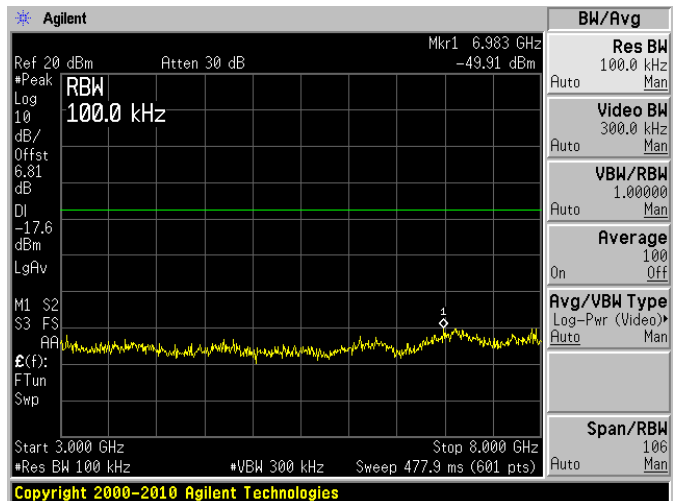



### High Channel

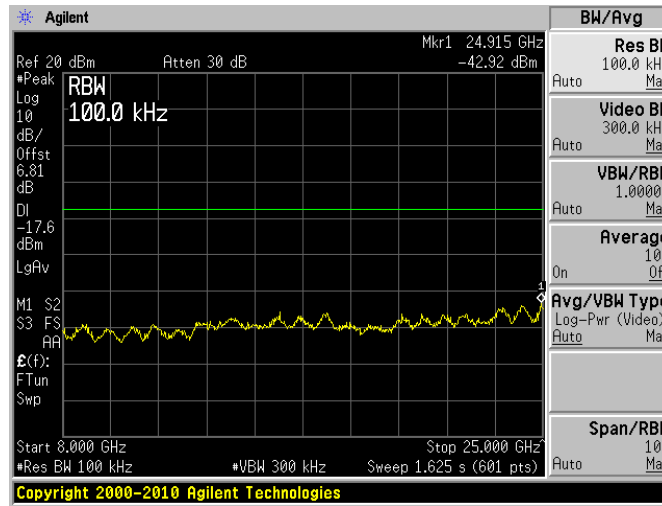

### 2.4 GHz, Antenna #2:

#### Low Channel

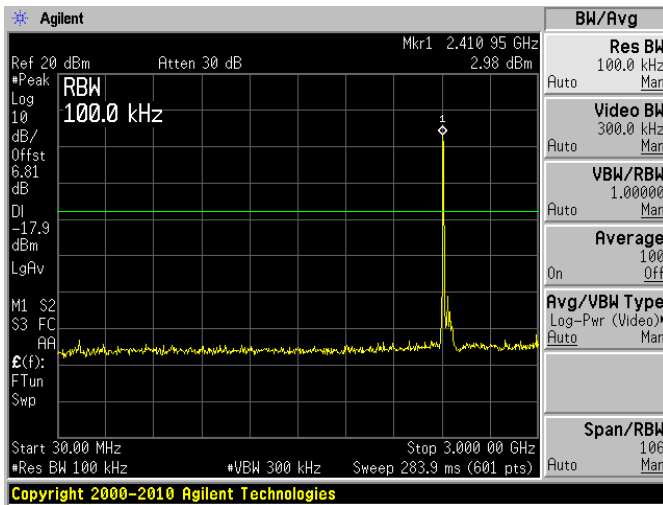

#### Low Channel

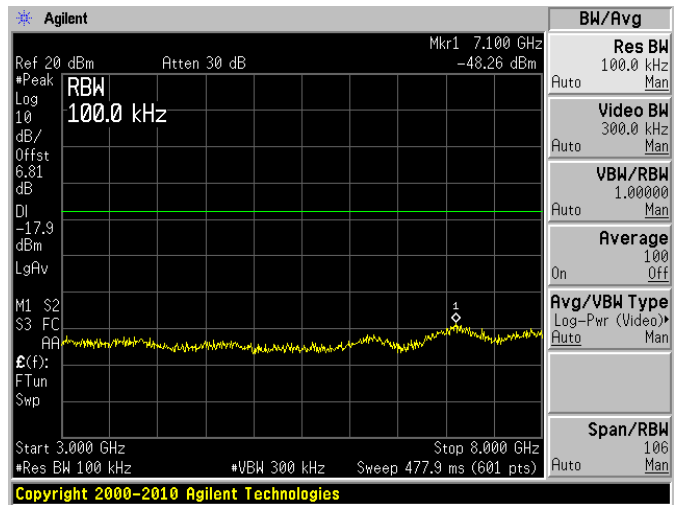

### Low Channel

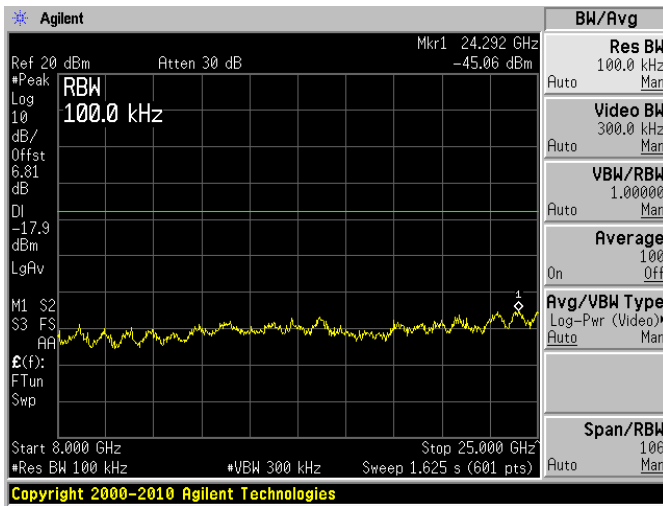

### Middle Channel

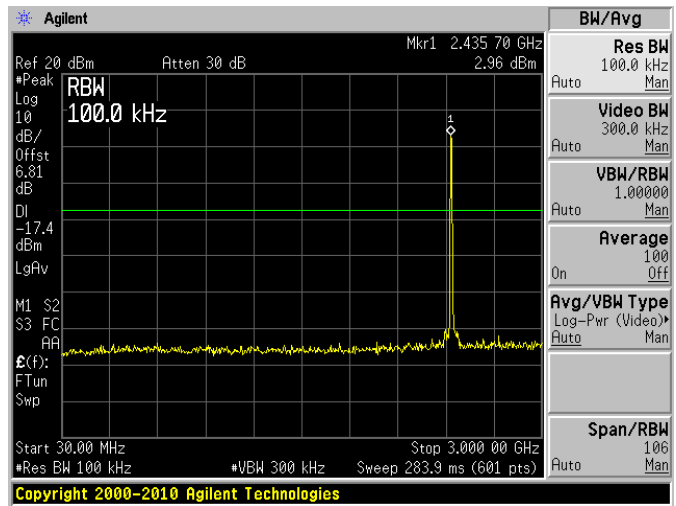

### Middle Channel

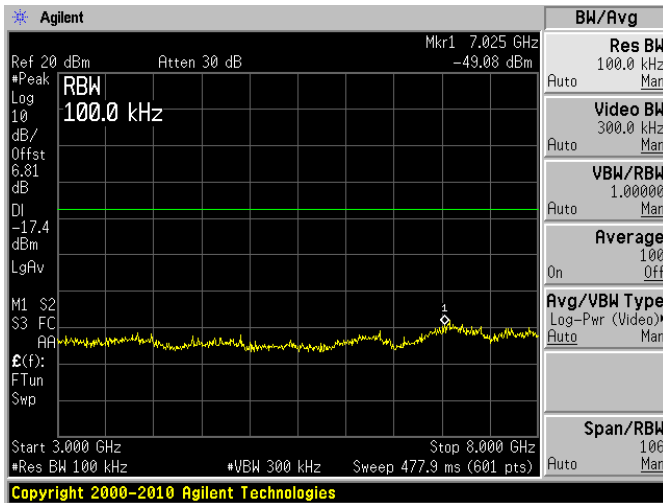

### Middle Channel

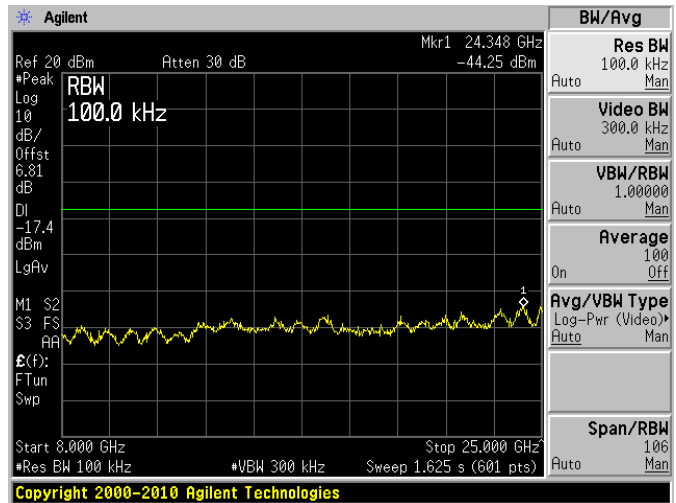

### High Channel

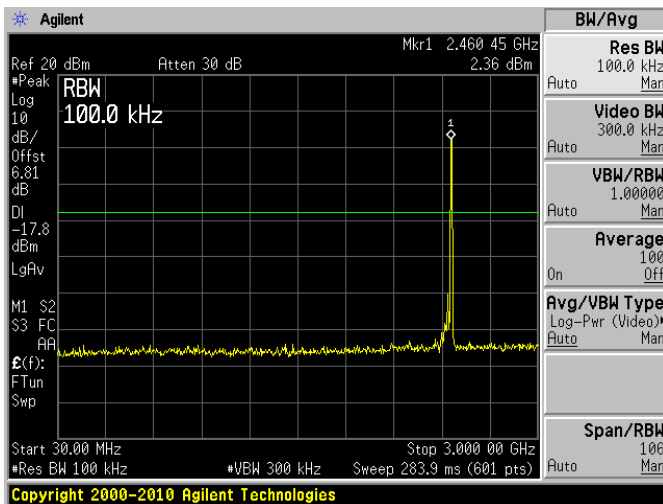

### High Channel

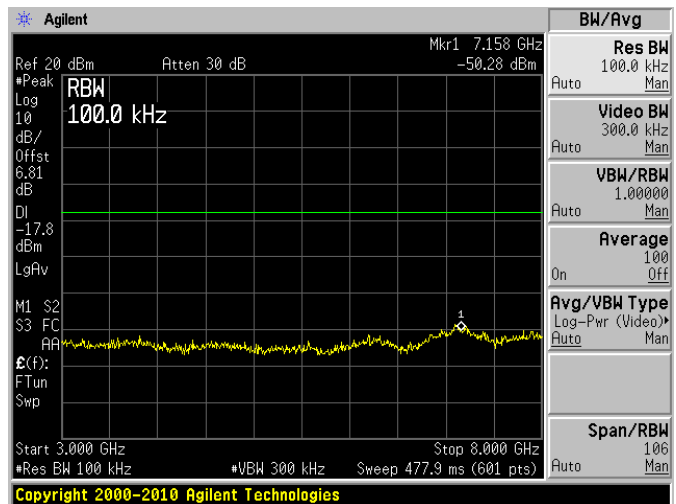

### High Channel

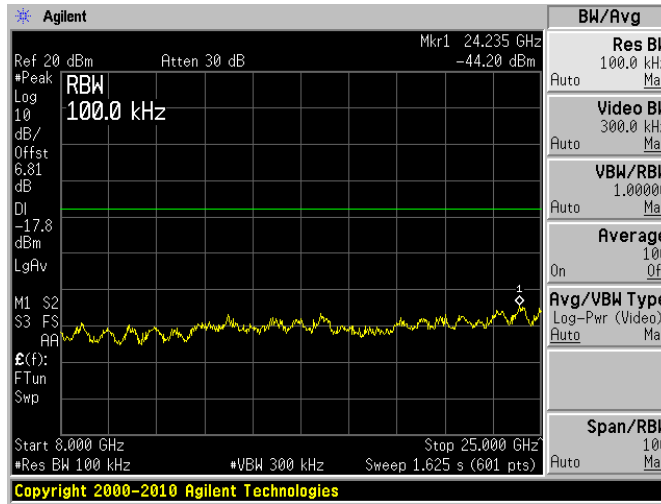

### 2.4 GHz, Antenna #3:

#### Low Channel

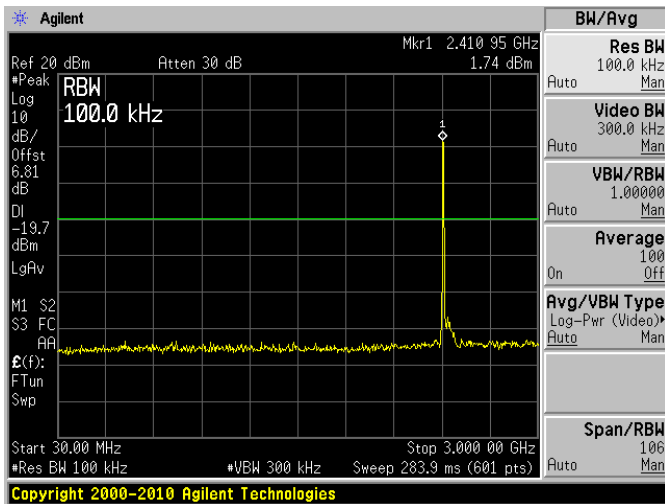

#### Low Channel

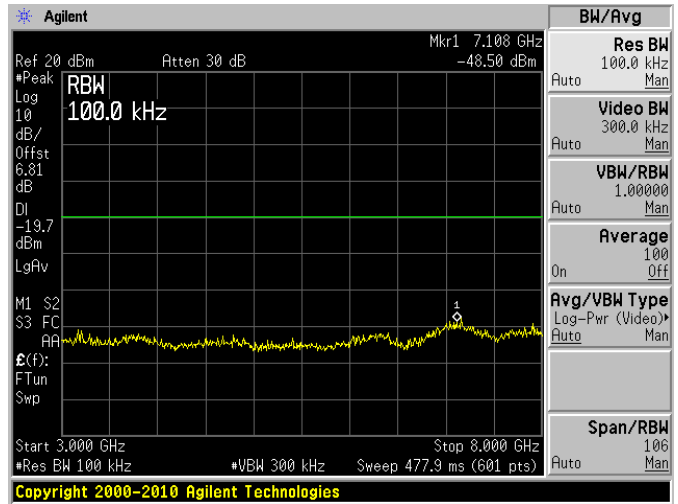

Low Channel

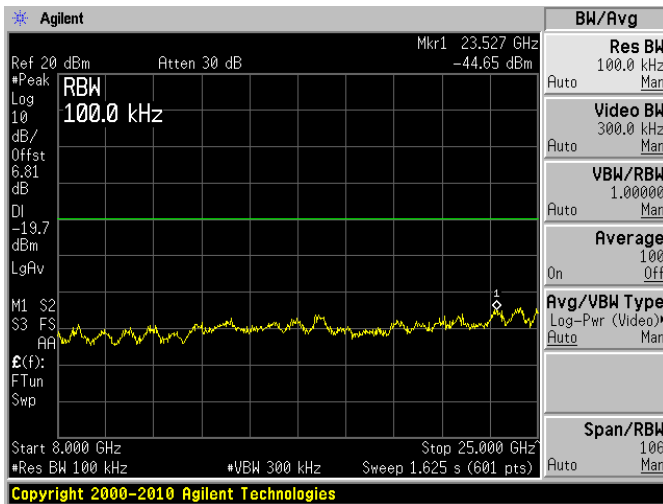

Middle Channel

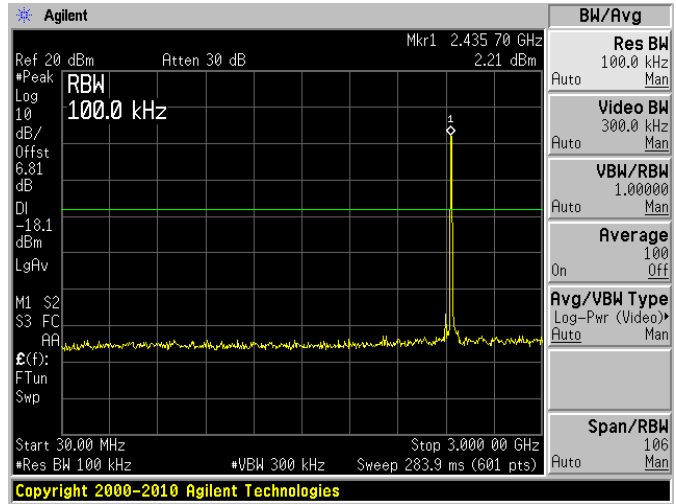

Middle Channel

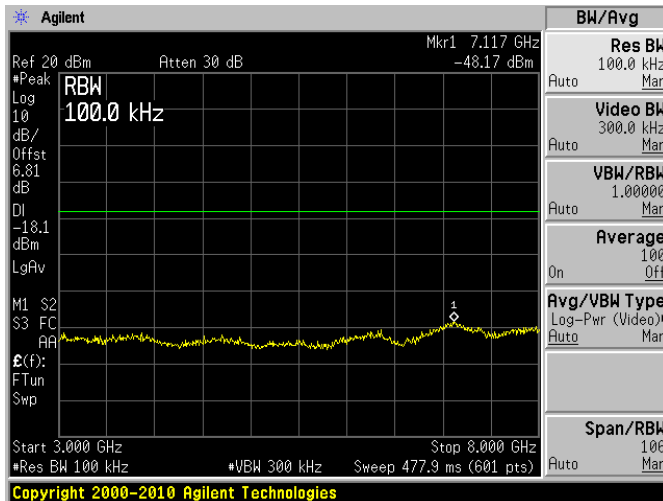

Middle Channel

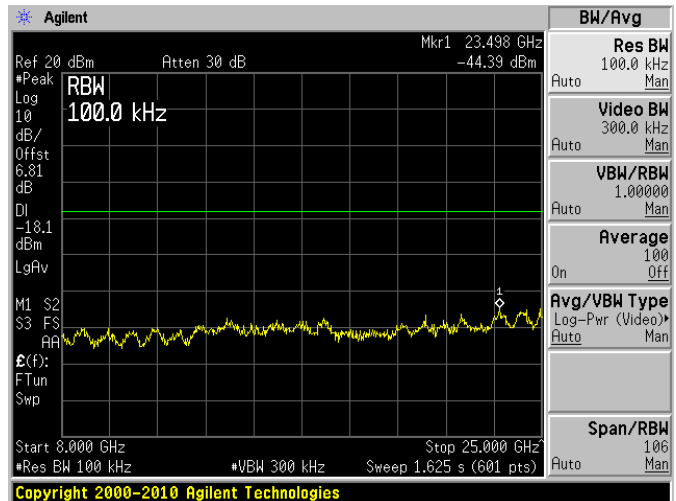

High Channel

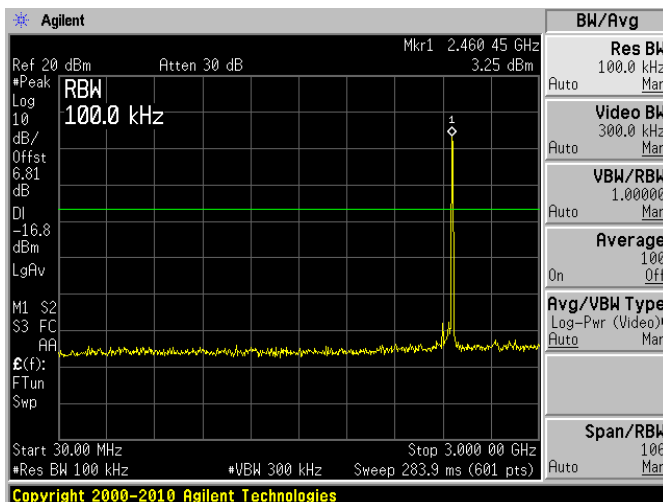

High Channel

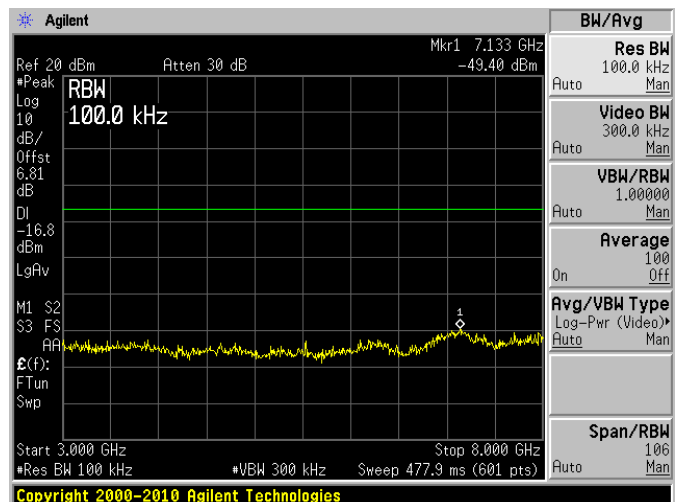

### High Channel

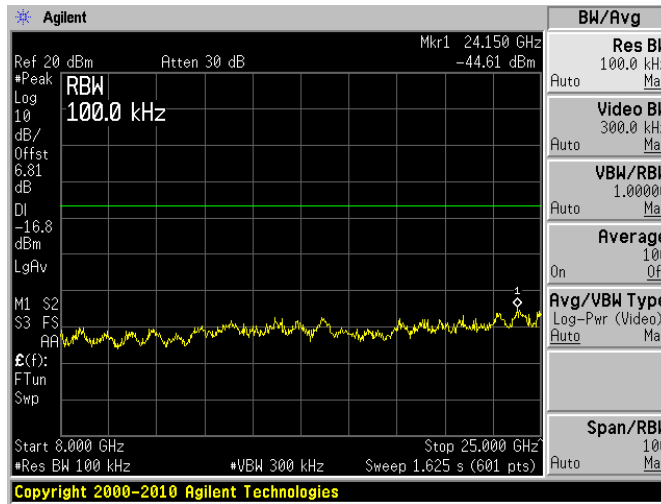

### 2.4 GHz Antenna #4:

#### Low Channel

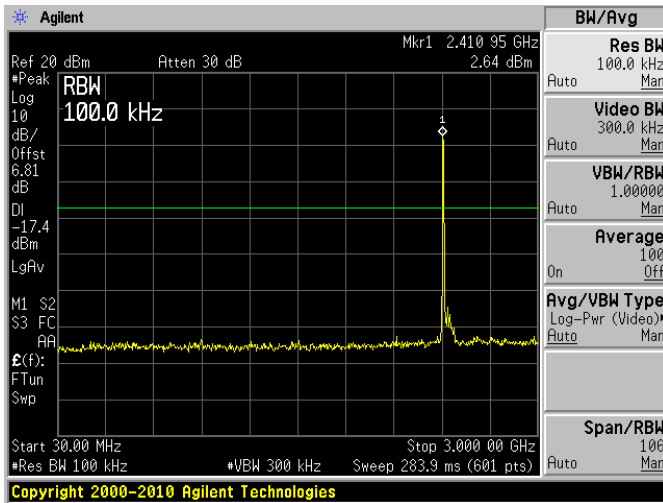

#### Low Channel

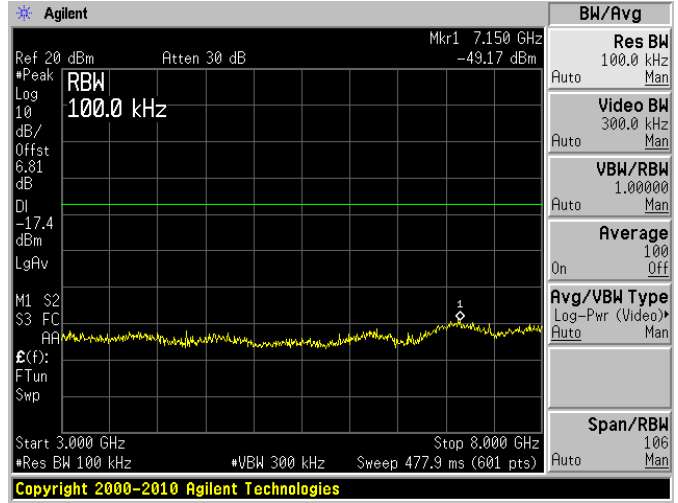

Low Channel

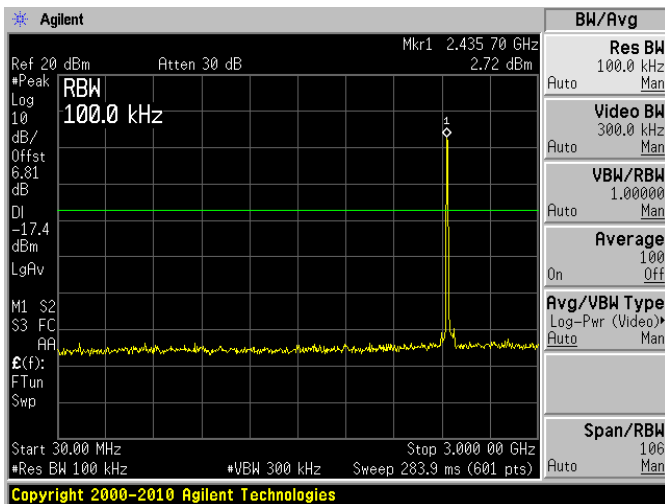

Middle Channel

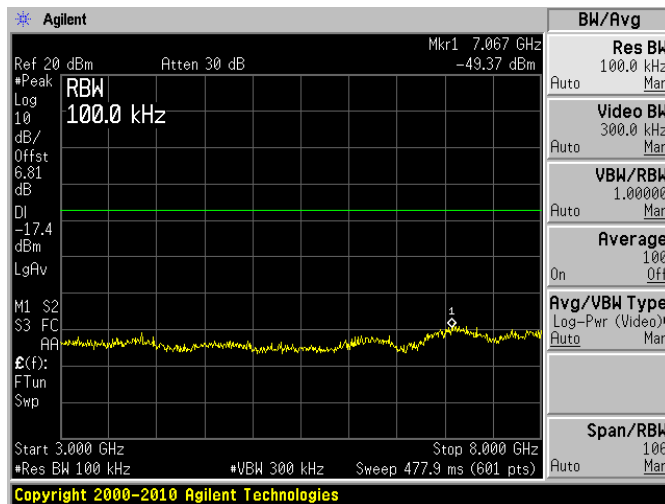

Middle Channel

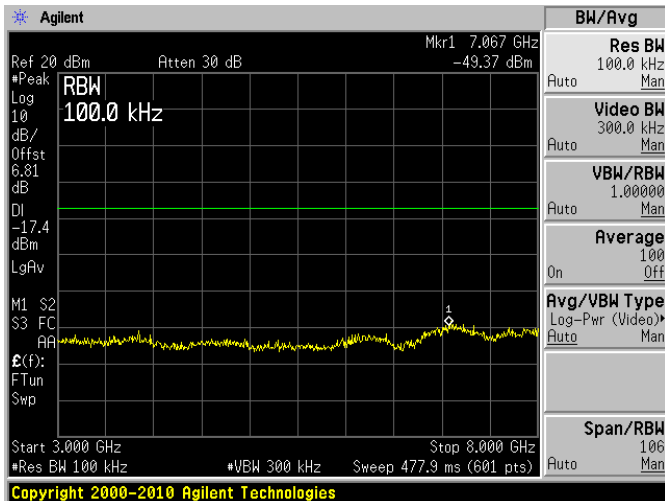

Middle Channel

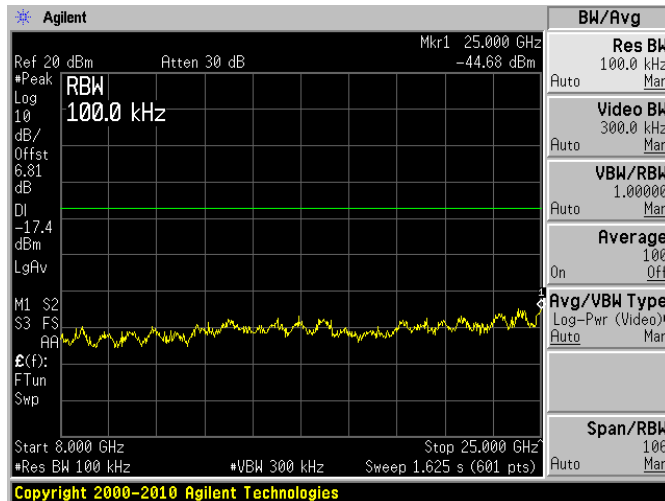

High Channel

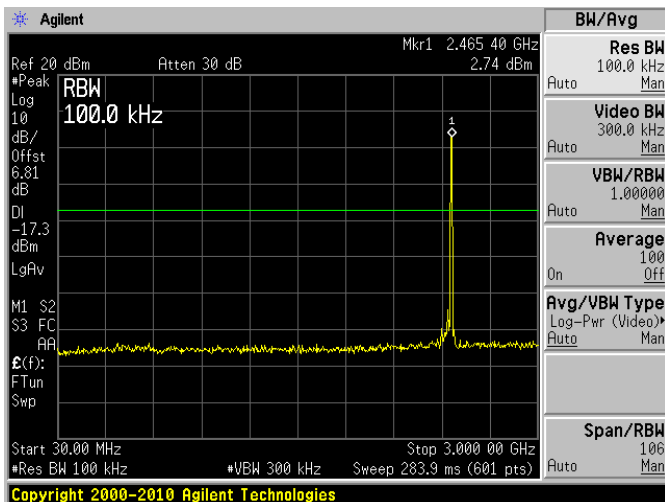

High Channel

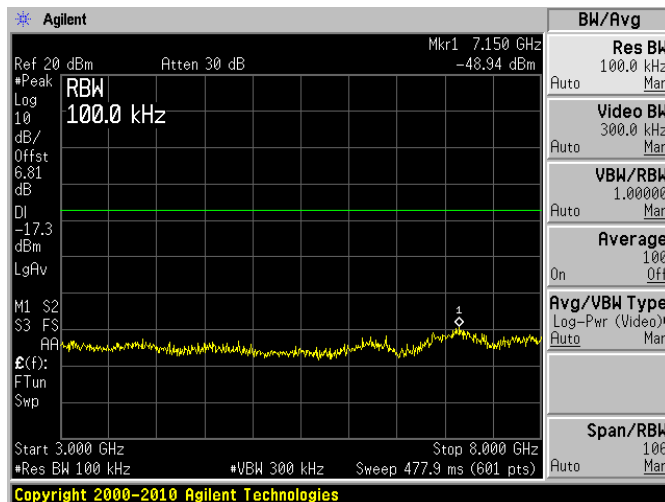

### High Channel

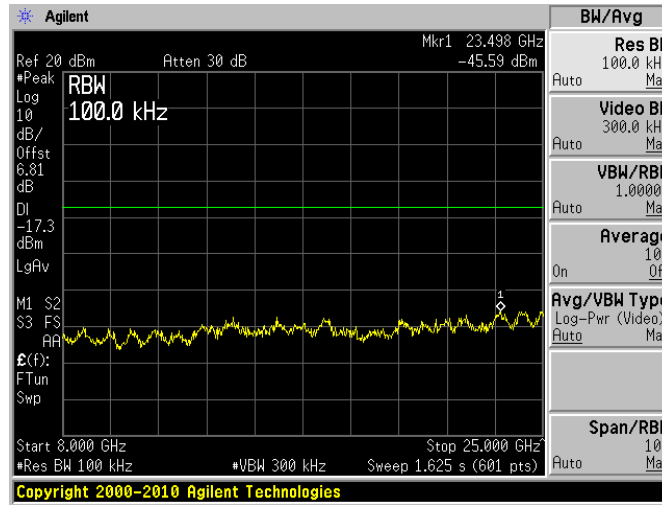

### 2.4 GHz, Antenna #1 + Antenna #2 + Antenna #3 + Antenna #4:

#### Low Channel

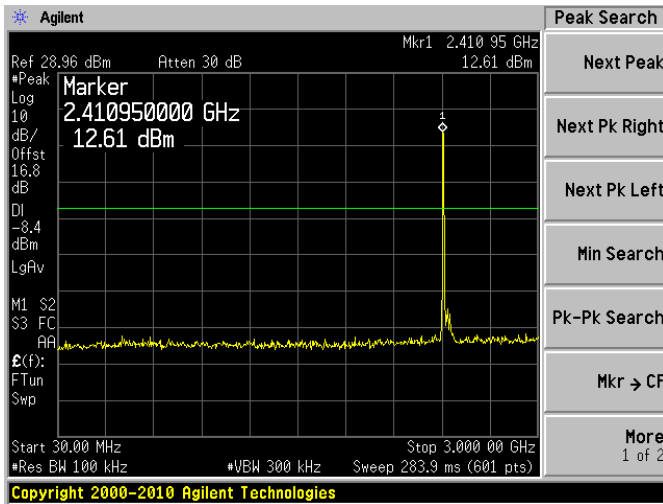

#### Low Channel

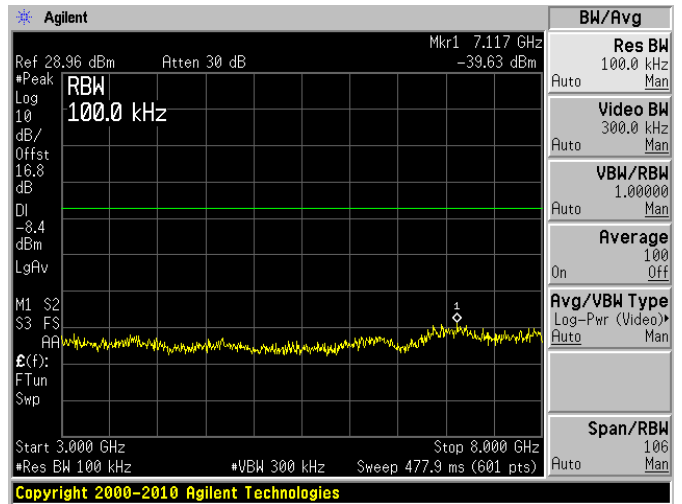

Low Channel

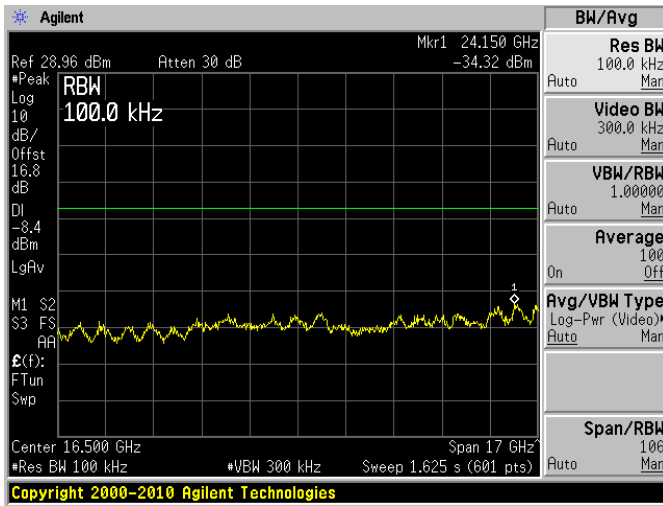

Middle Channel

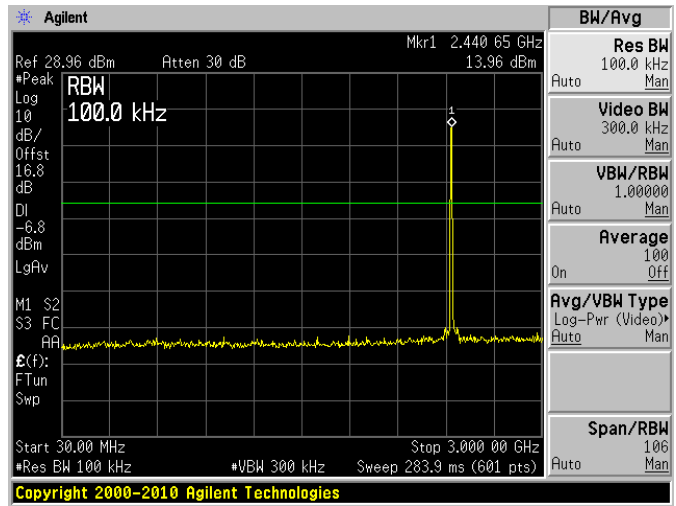

Middle Channel

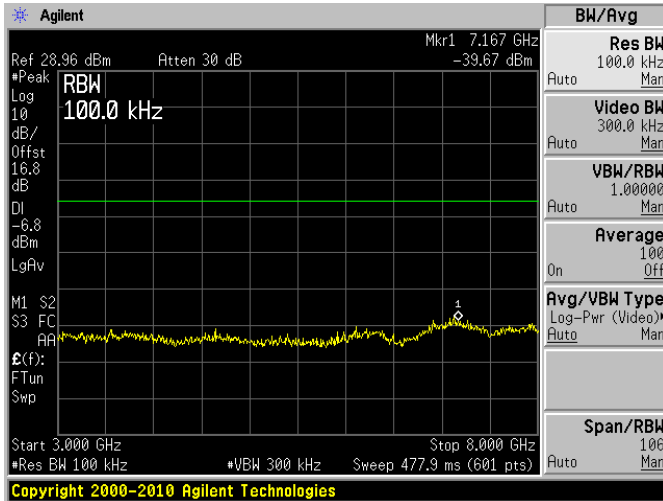

Middle Channel

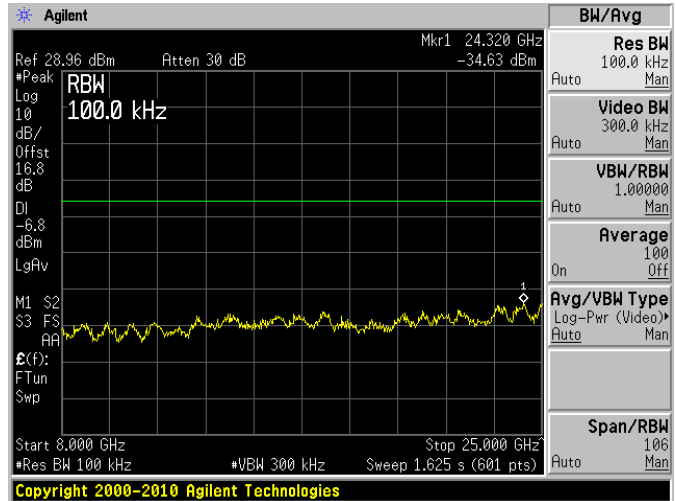

High Channel

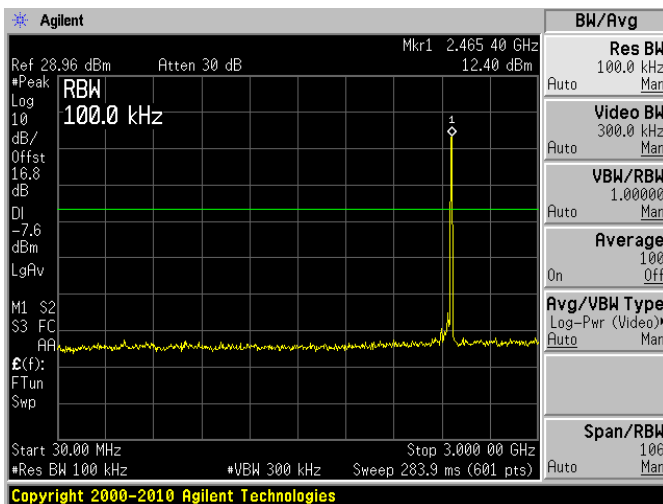

High Channel

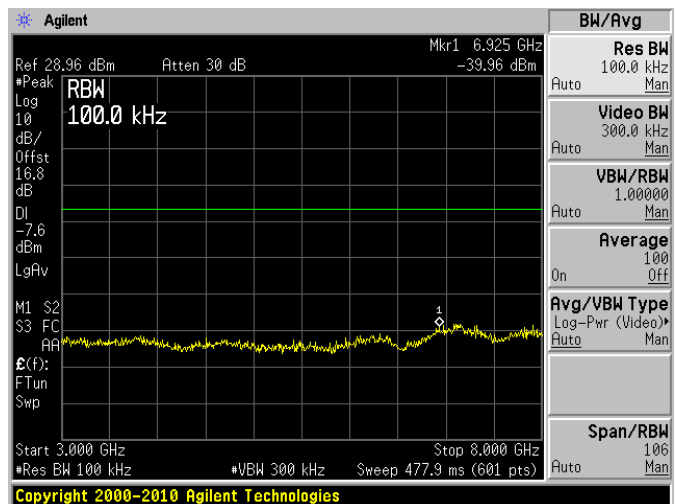



### High Channel

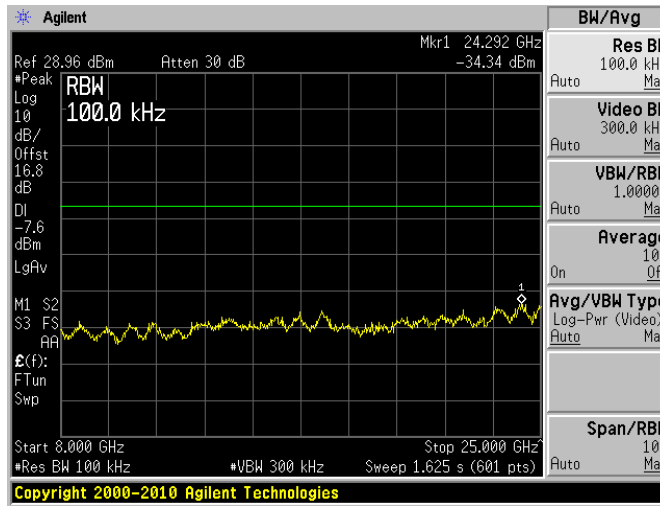

2.4 GHz Band (2412–2462 MHz): BPSK with 20 MHz bandwidth, EIRP +36 dBm

### 2.4 GHz, Antenna #1:

#### Low Channel

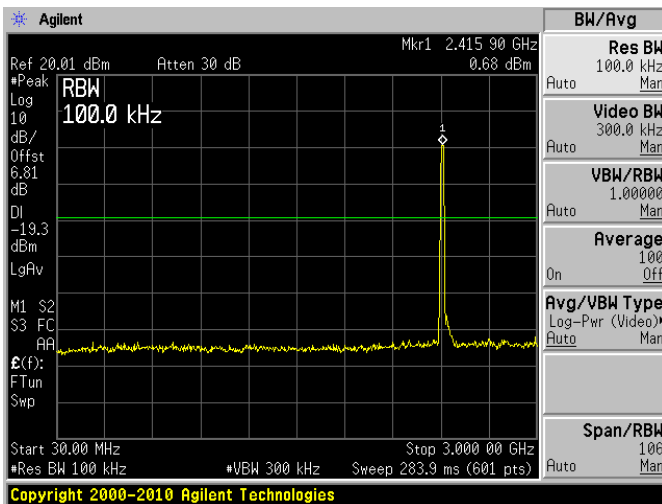

#### Low Channel

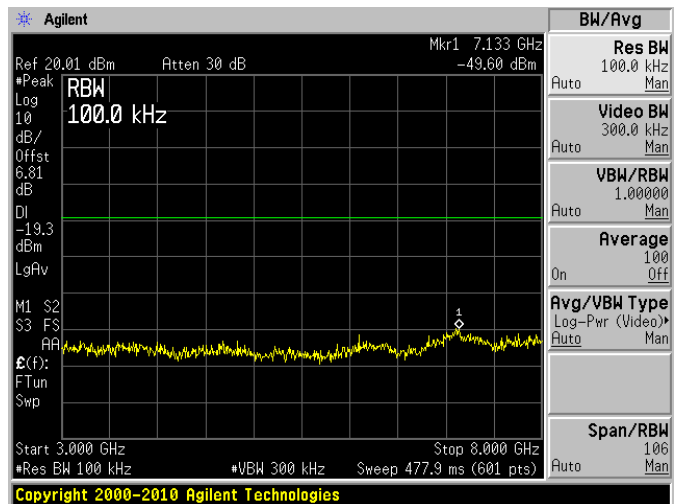

Low Channel

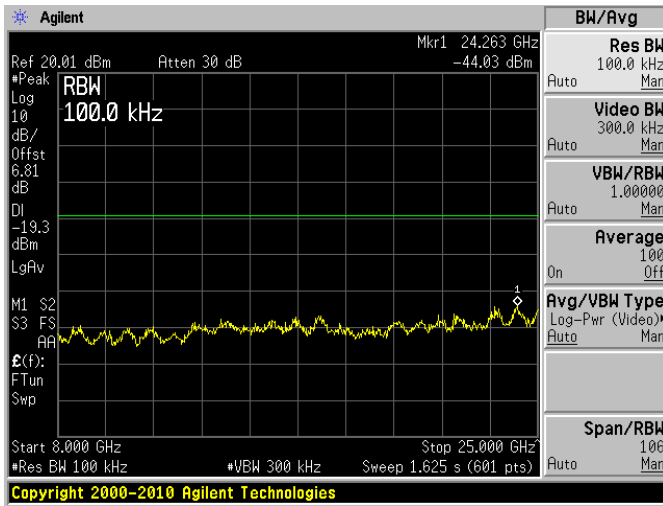

Middle Channel

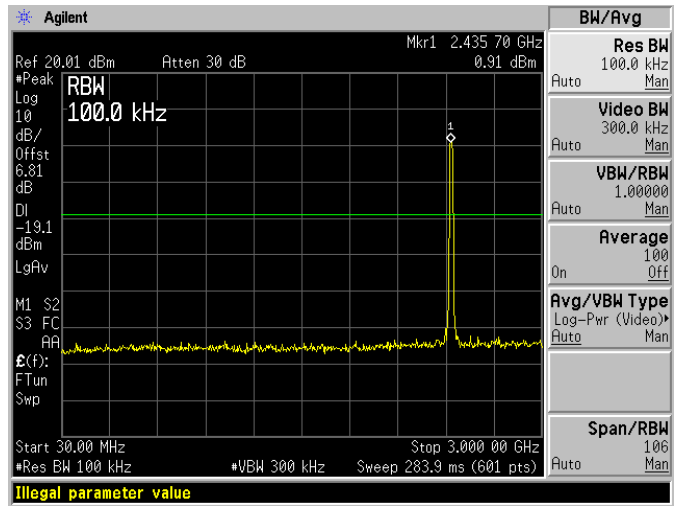

Middle Channel

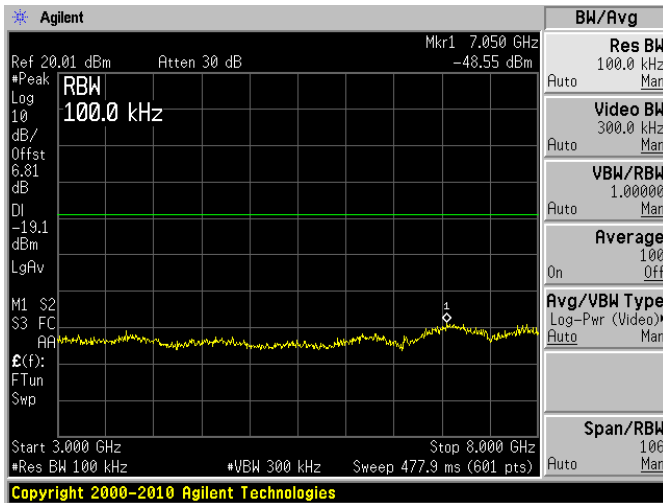

Middle Channel

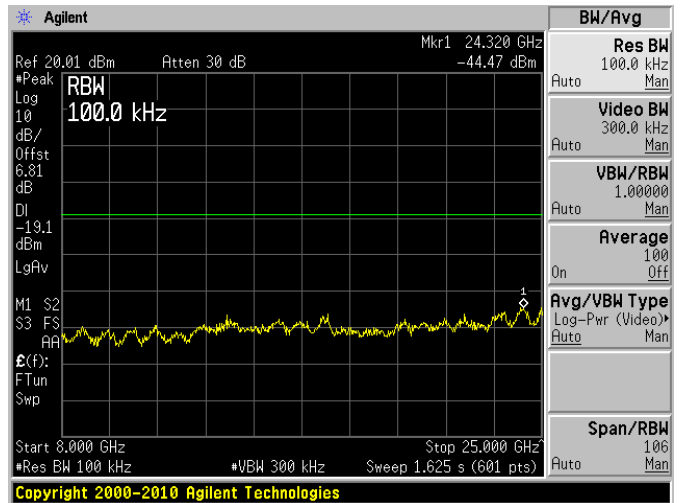

High Channel

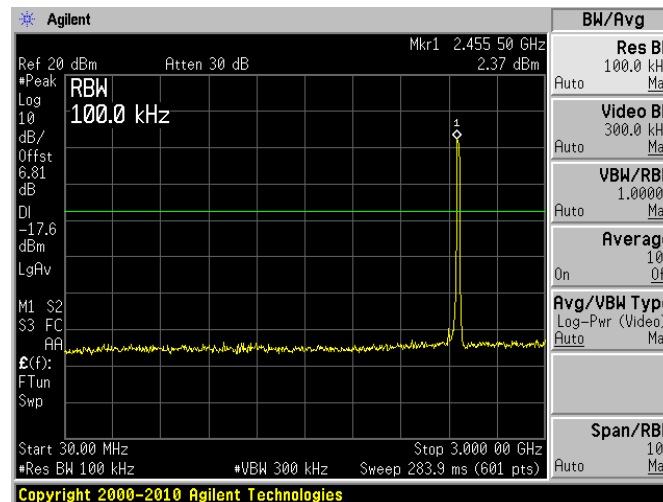

High Channel

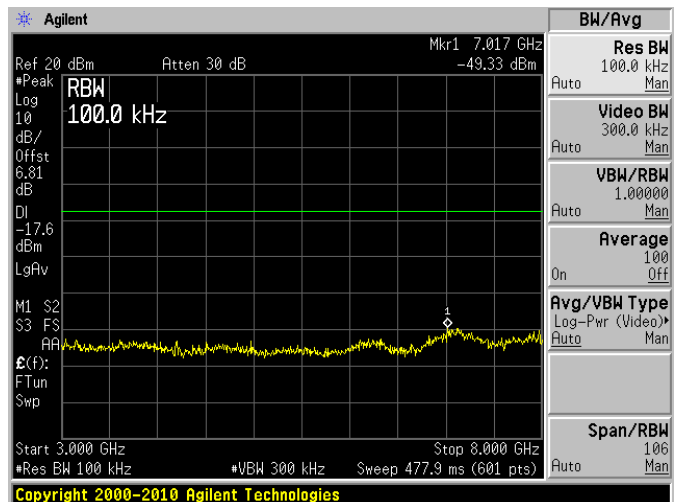

### High Channel

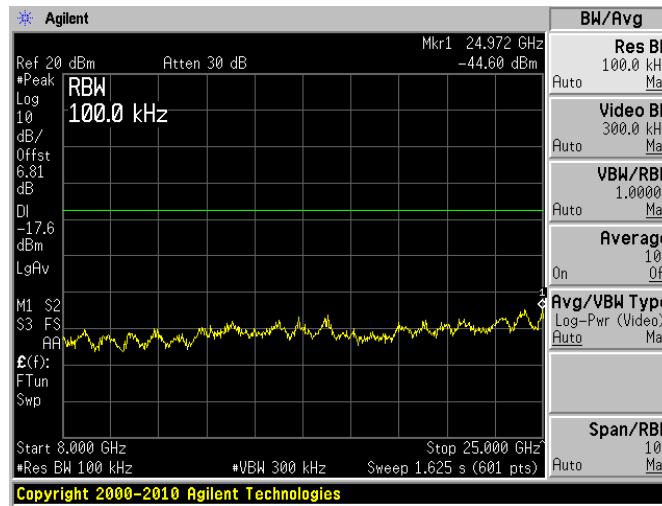

### 2.4 GHz, Antenna #2:

#### Low Channel

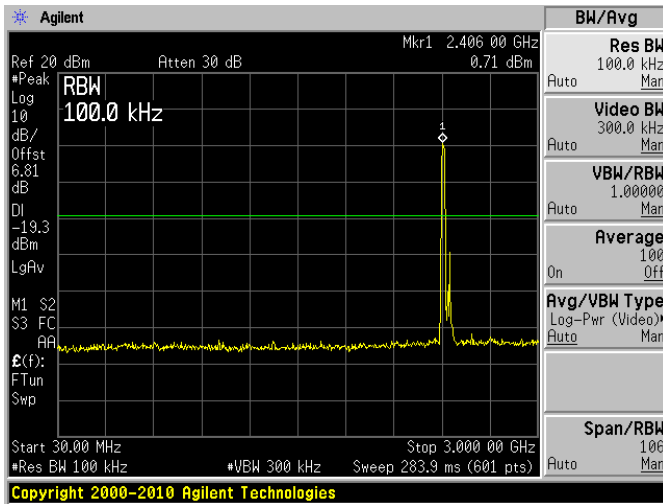

#### Low Channel

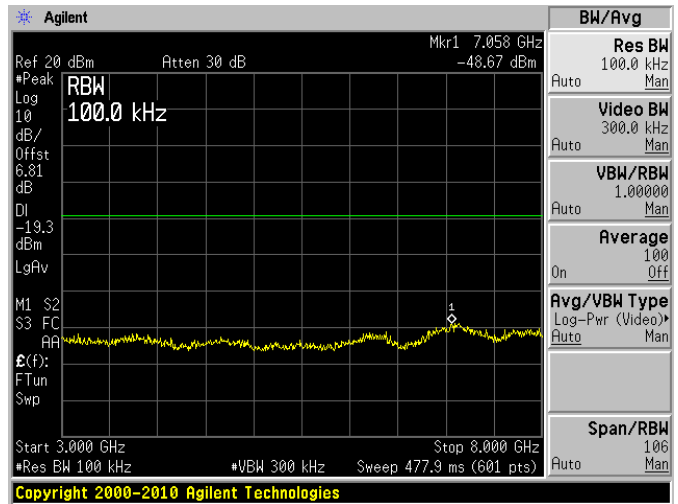

Low Channel

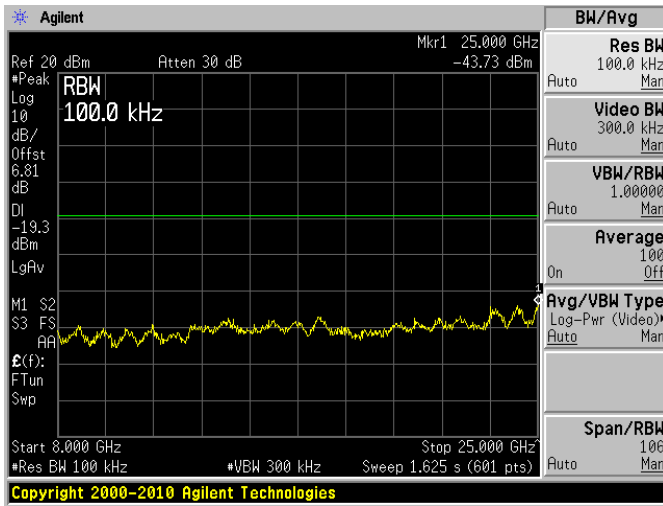

Middle Channel

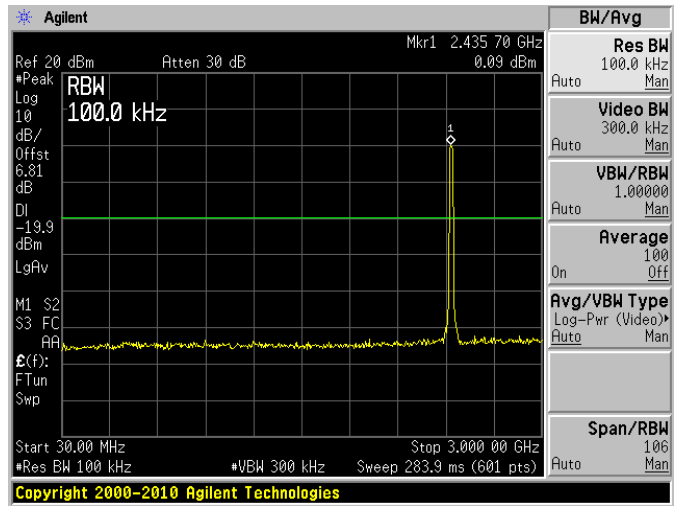

Middle Channel

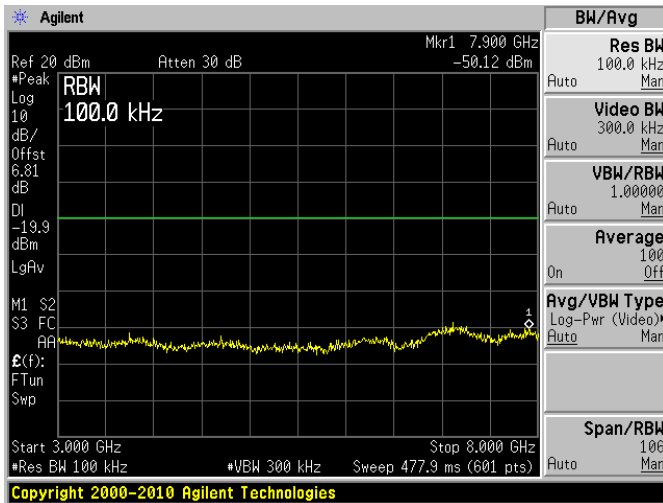

Middle Channel

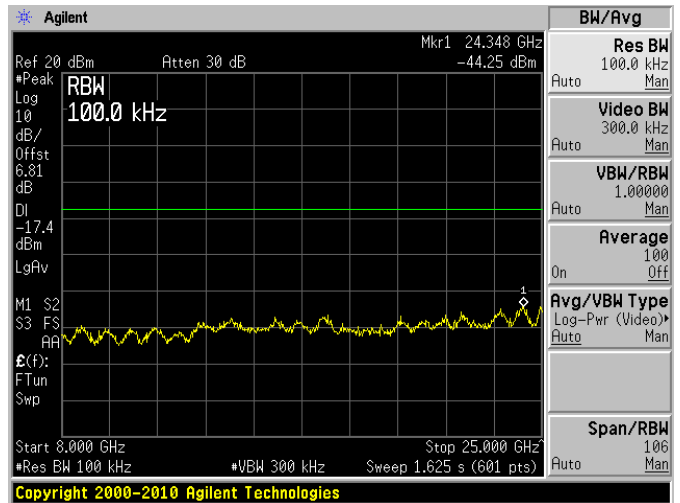

High Channel

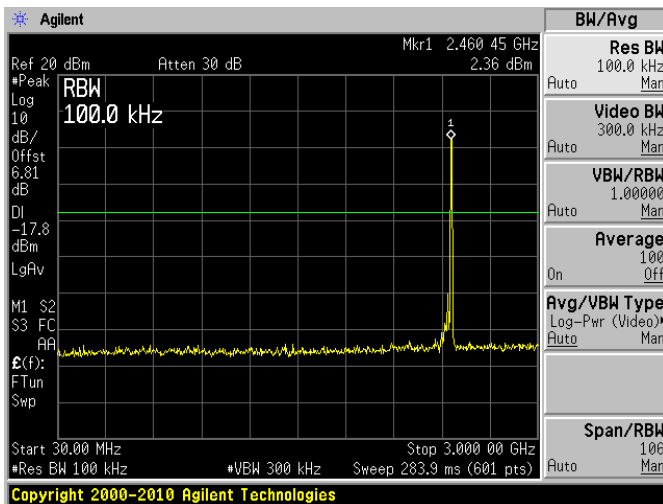

High Channel

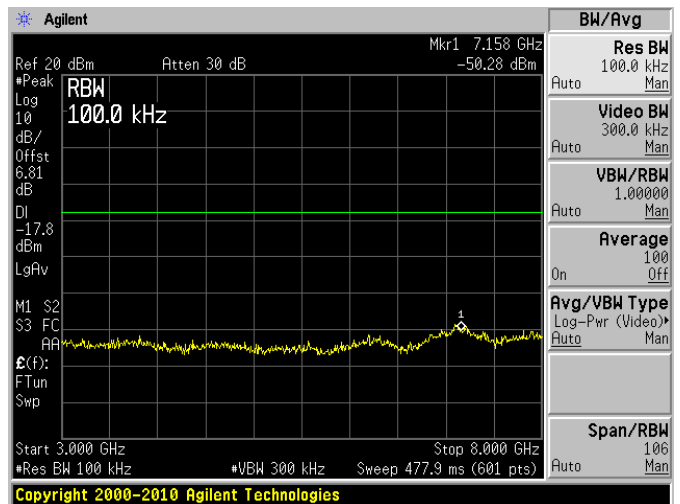

### High Channel

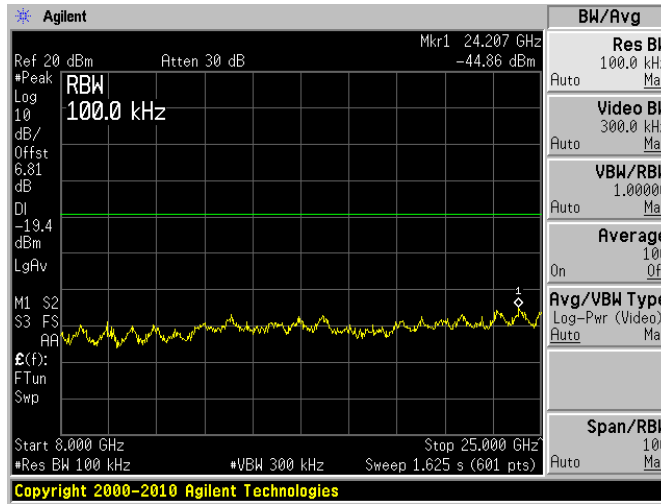

2.4 GHz, Antenna #3:

### Low Channel

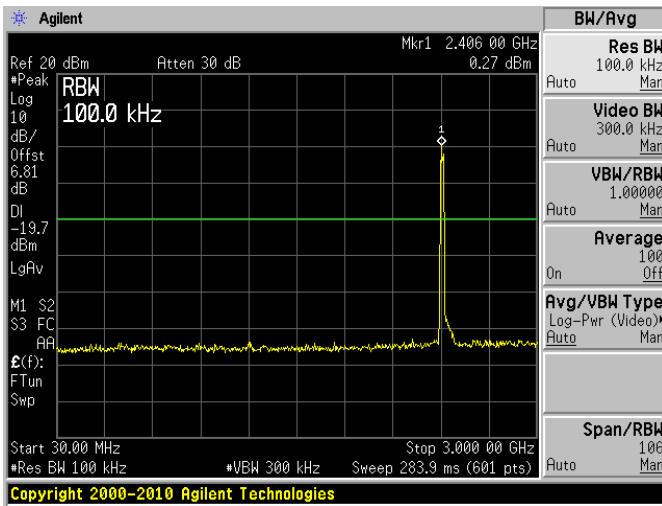

### Low Channel

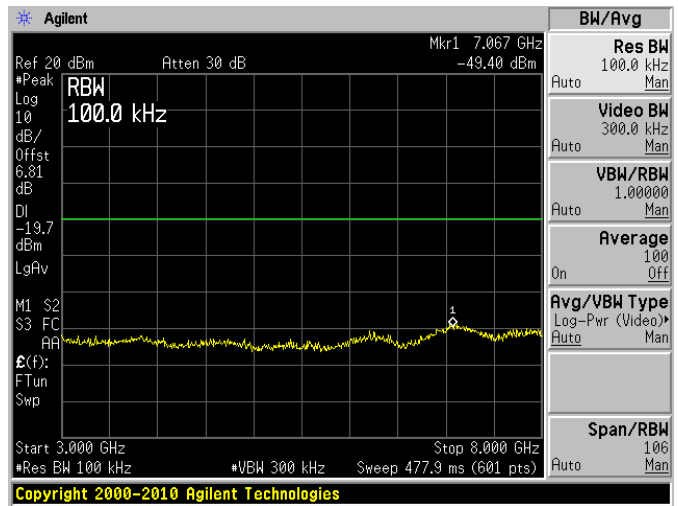

Low Channel

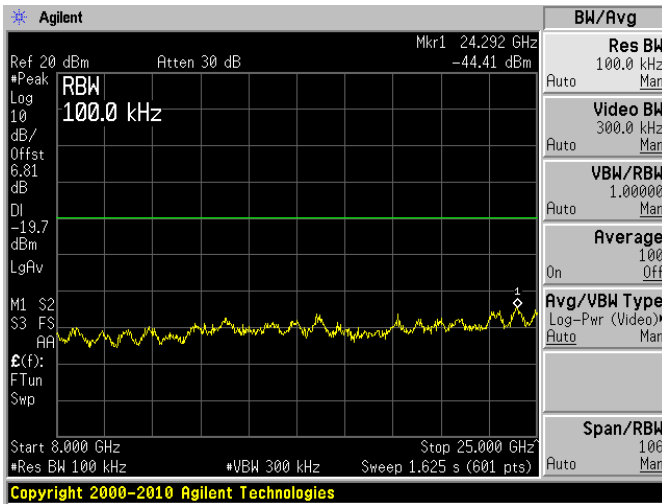

Middle Channel

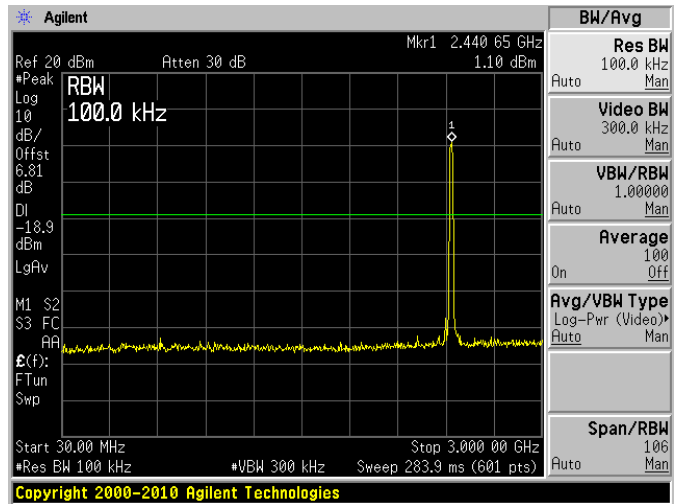

Middle Channel

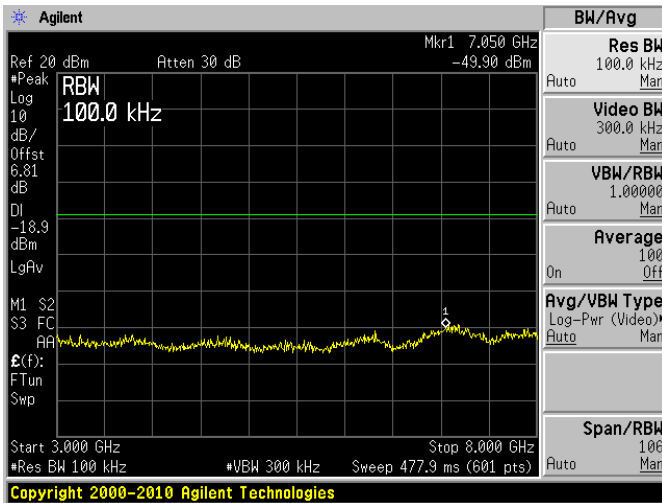

Middle Channel

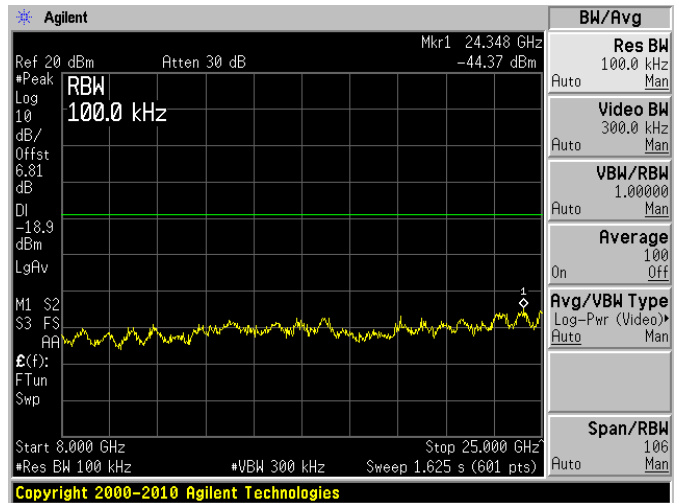

High Channel

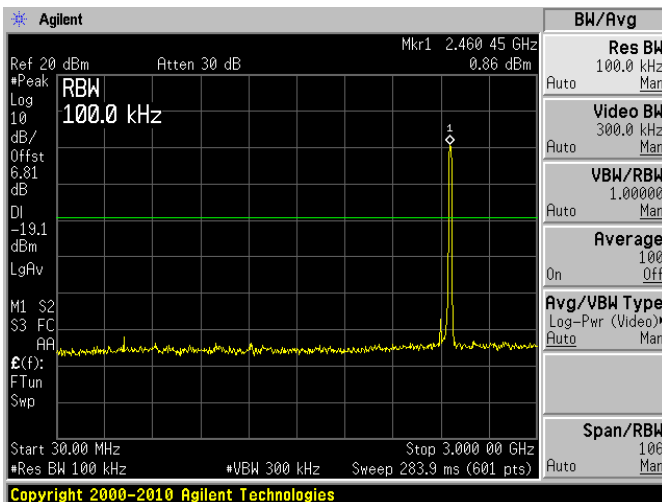

High Channel

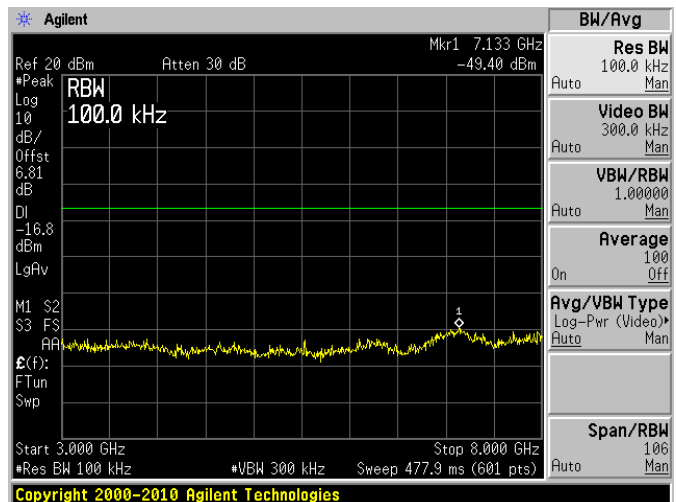

### High Channel

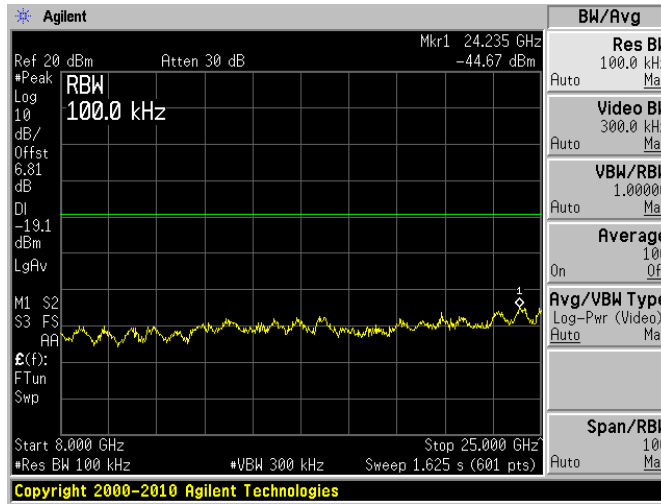

### 2.4 GHz, Antenna #4:

#### Low Channel

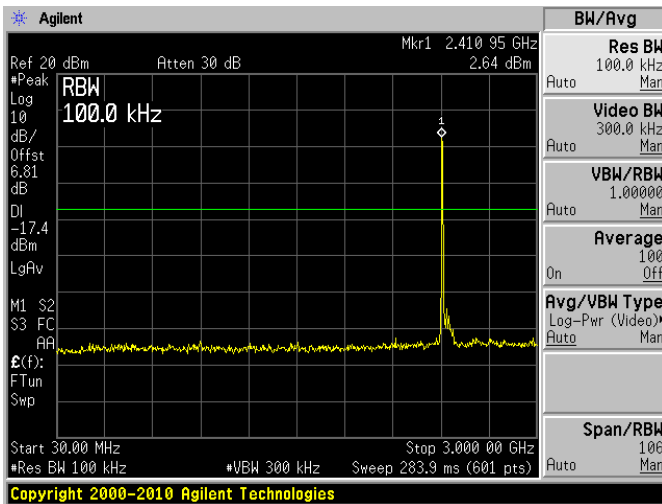

#### Low Channel

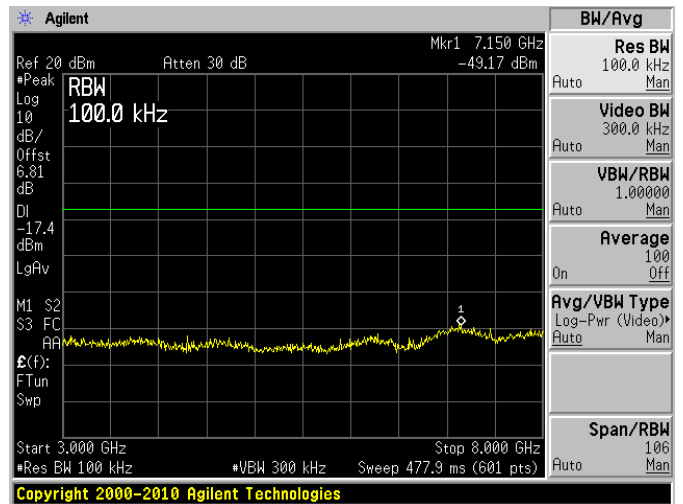

Low Channel

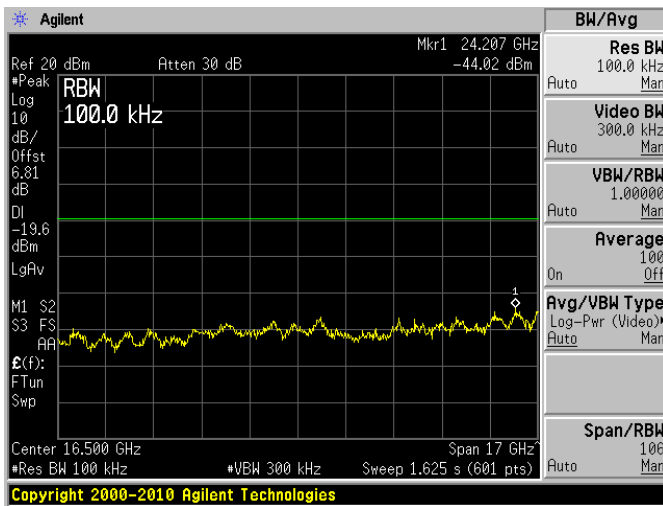

Middle Channel

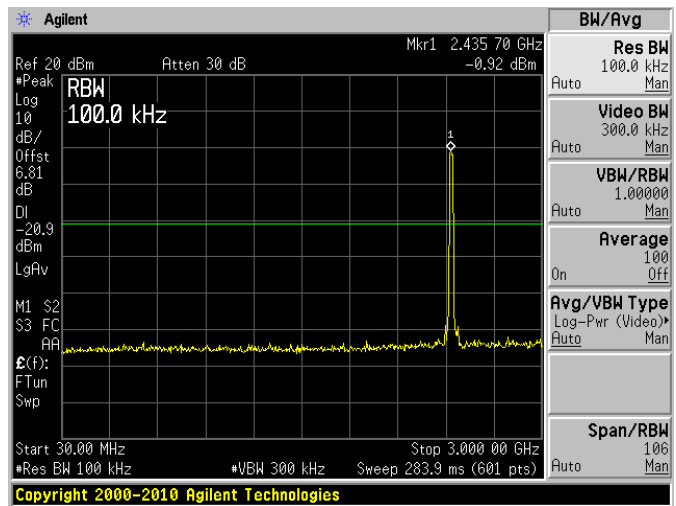

Middle Channel

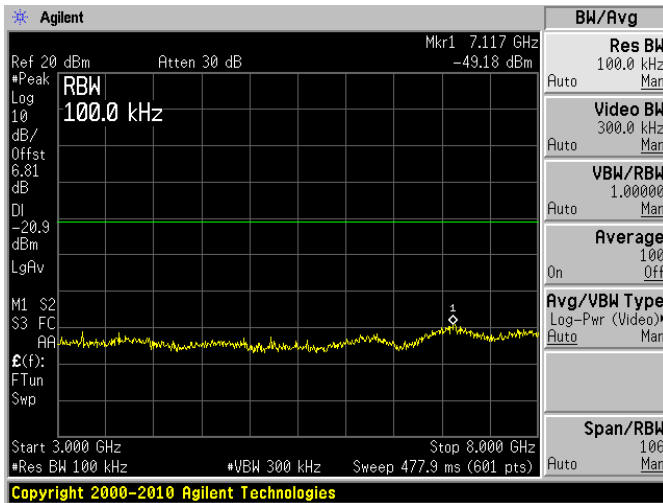

Middle Channel

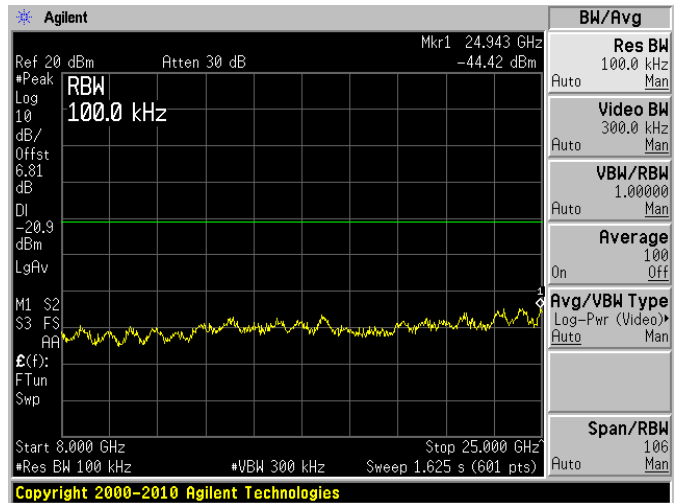

High Channel

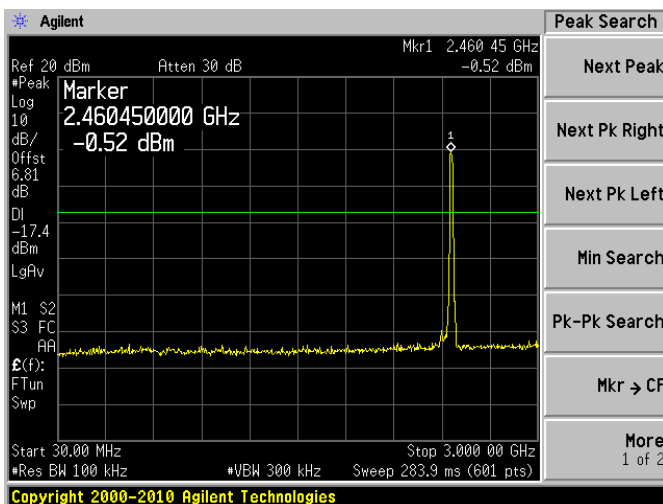

High Channel

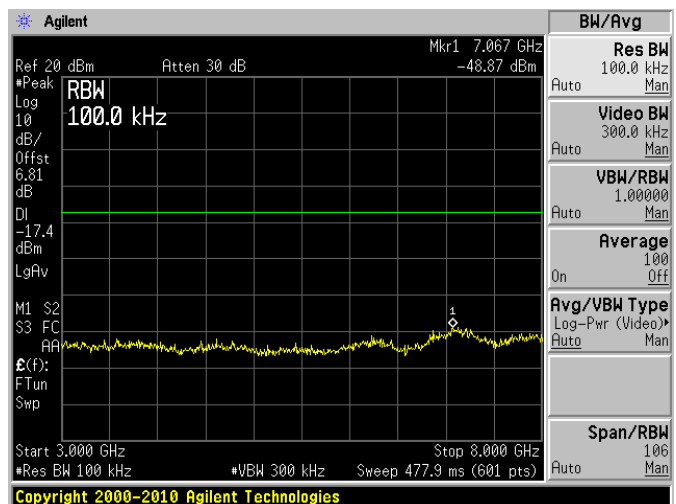



### High Channel

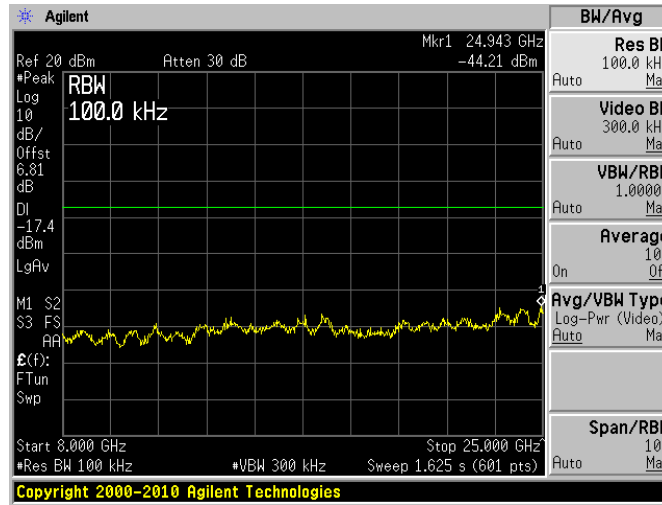

### 2.4 GHz, Antenna #1 + Antenna #2 + Antenna #3 + Antenna #4:

#### Low Channel

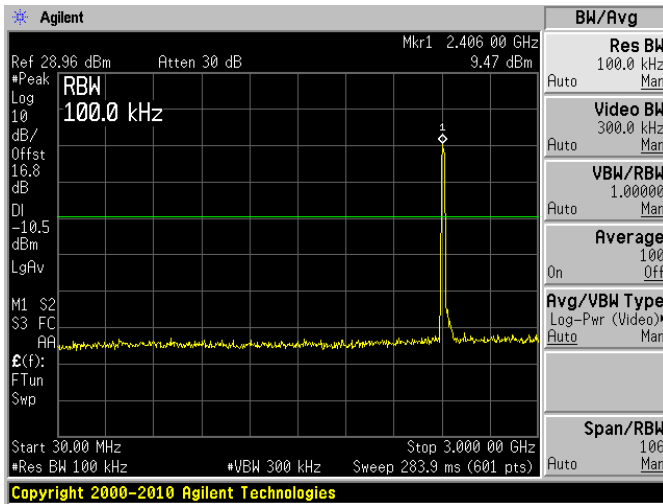

#### Low Channel

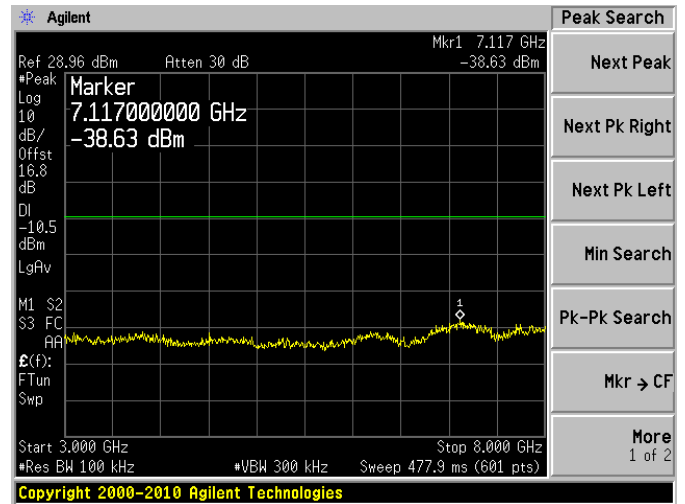

Low Channel

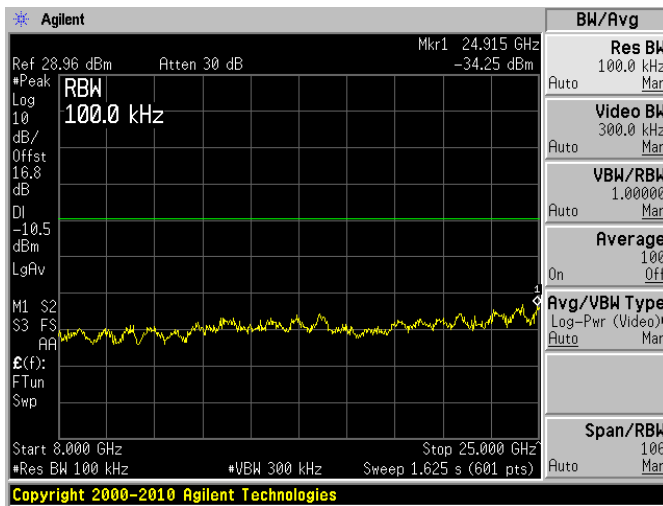

Middle Channel

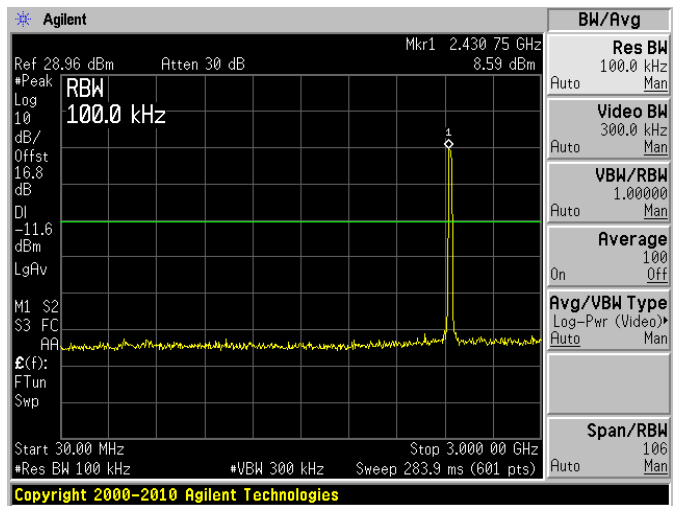

Middle Channel

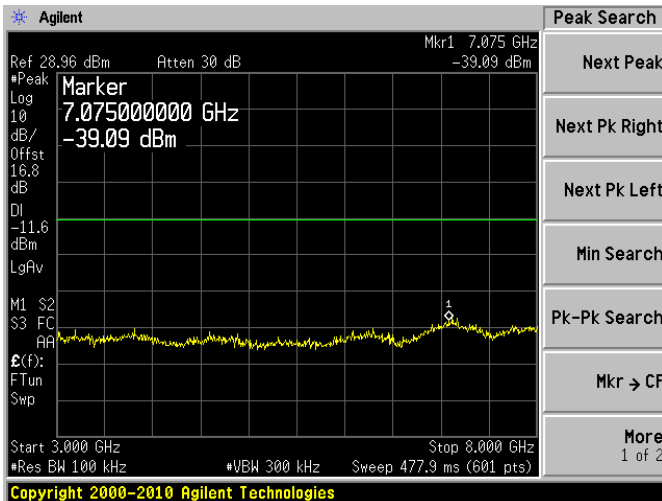

Middle Channel

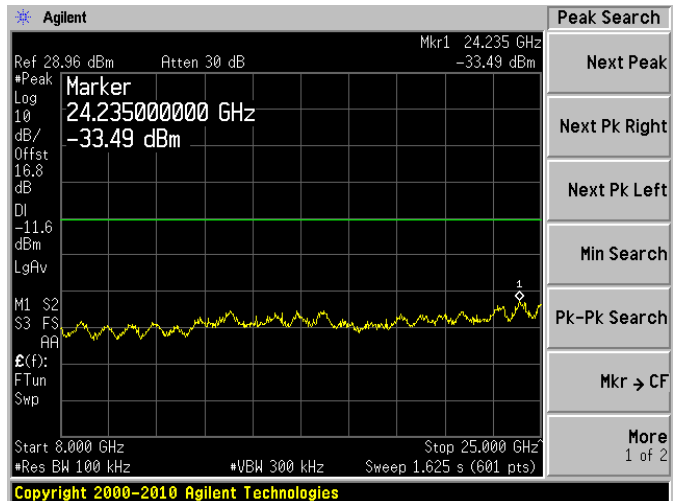

High Channel

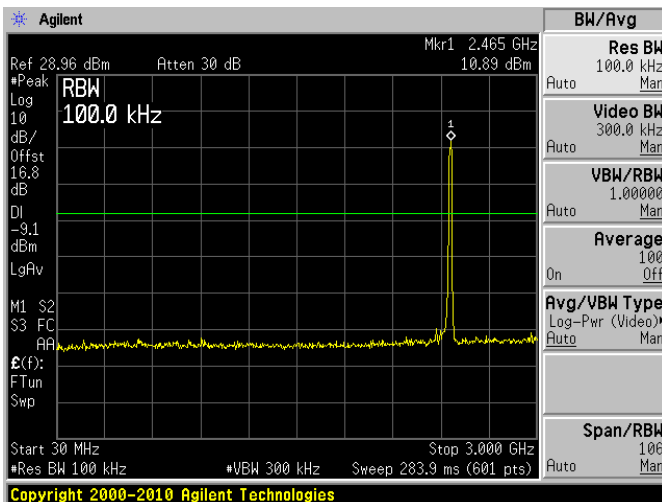

High Channel

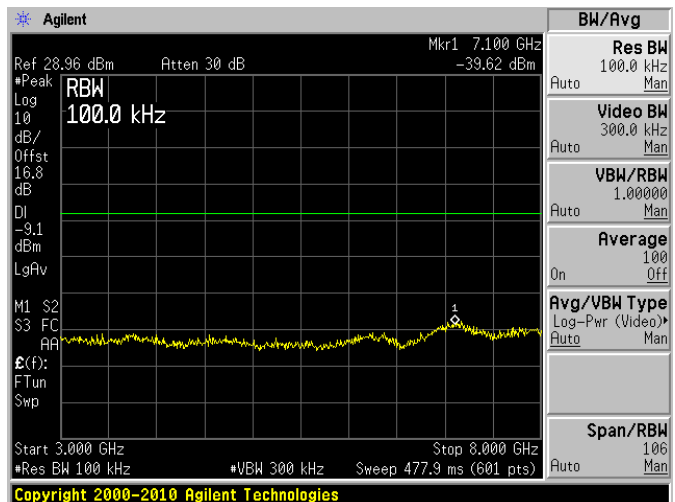

### High Channel

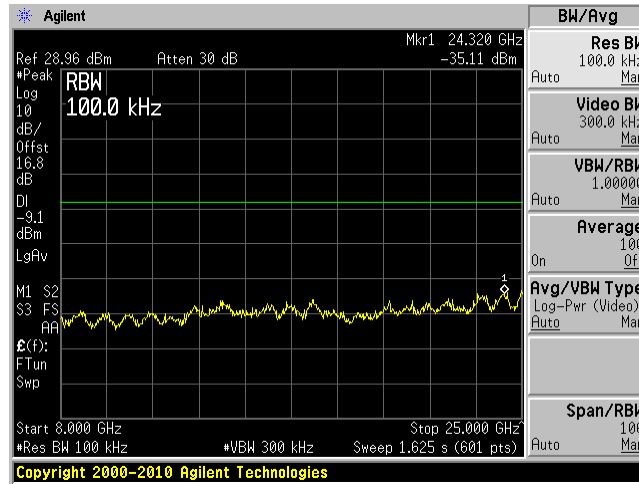

**5.8 GHz Band (5745– 5825 MHz): BPSK with 5 MHz bandwidth, EIRP +36 dBm**

### 5.8 GHz, Antenna #1:

#### Low Channel

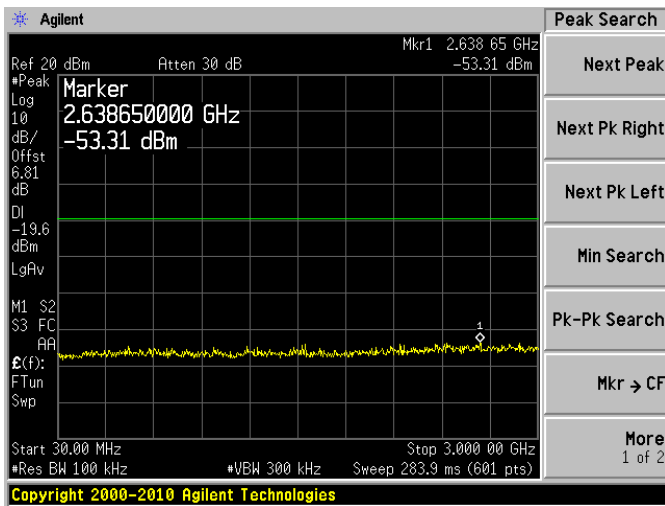

#### Low Channel

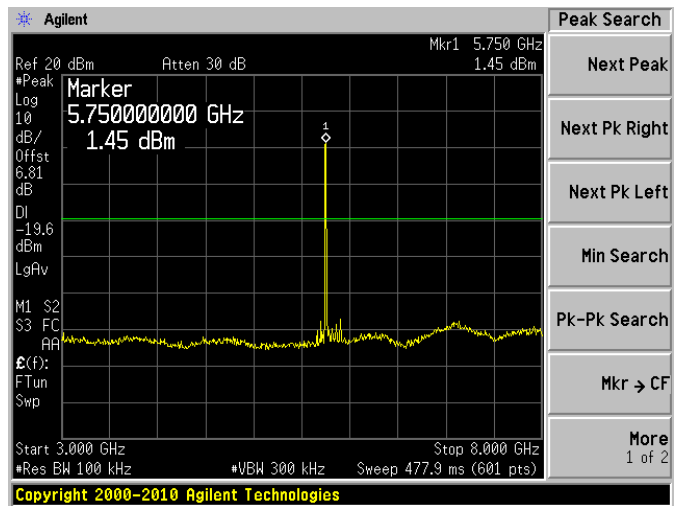

Low Channel

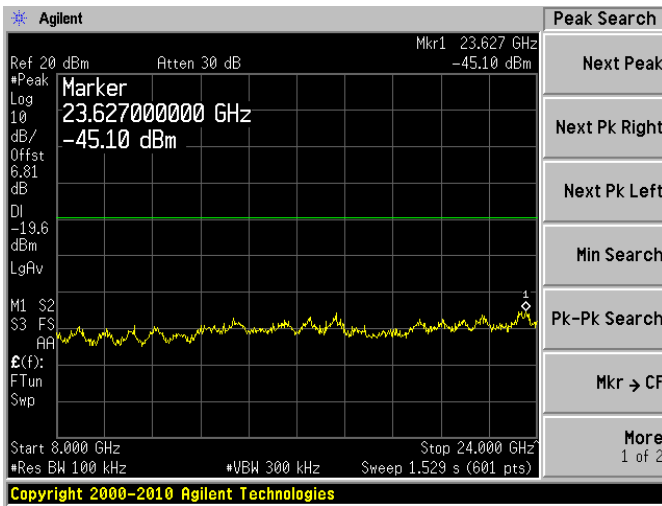

Low Channel

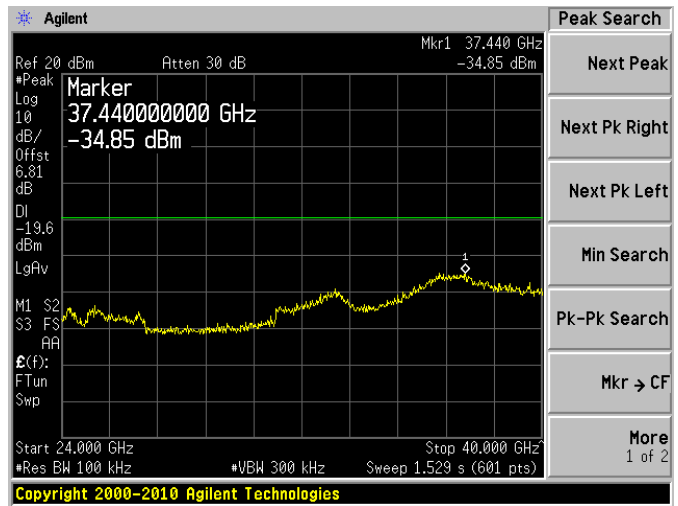

Middle Channel

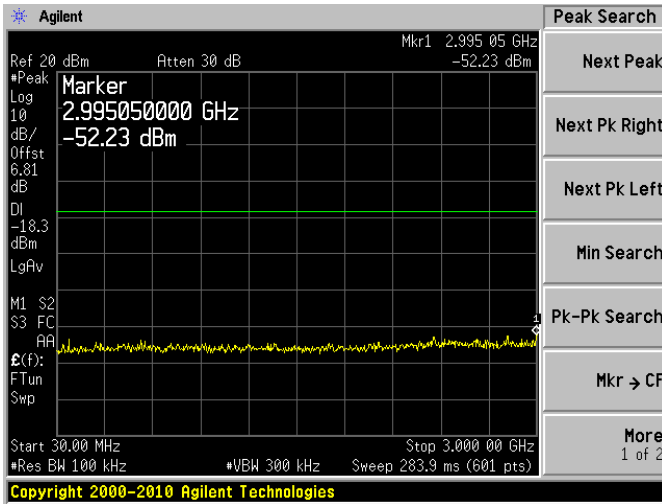

Middle Channel

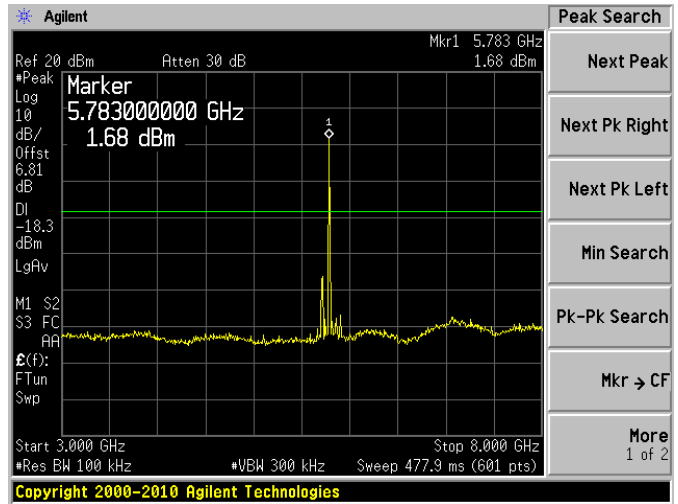

Middle Channel

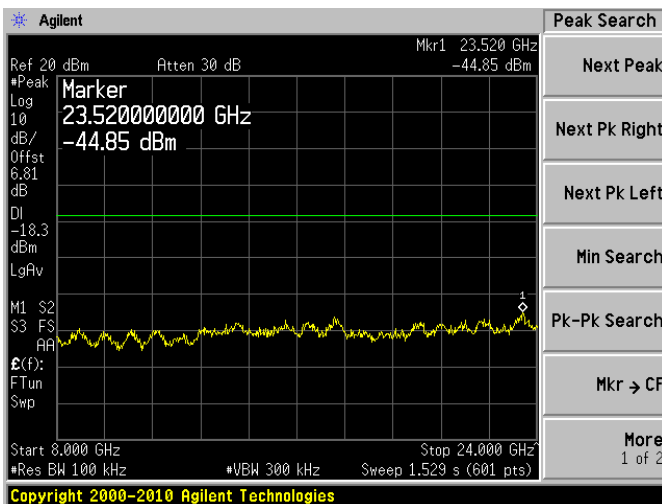

Middle Channel

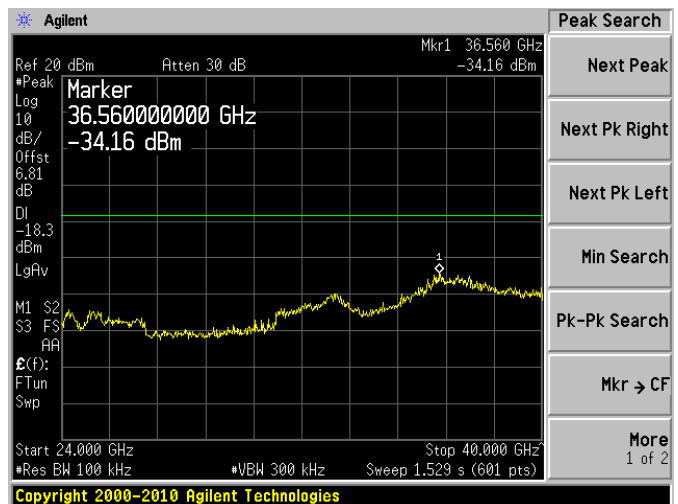

High Channel

High Channel

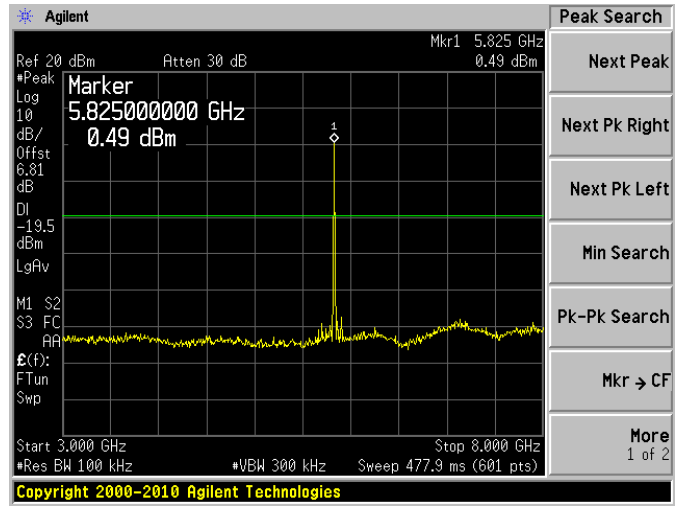
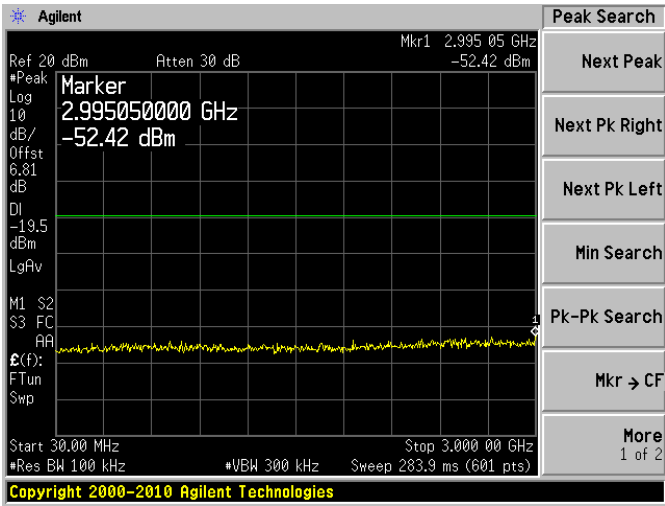

High Channel

High Channel

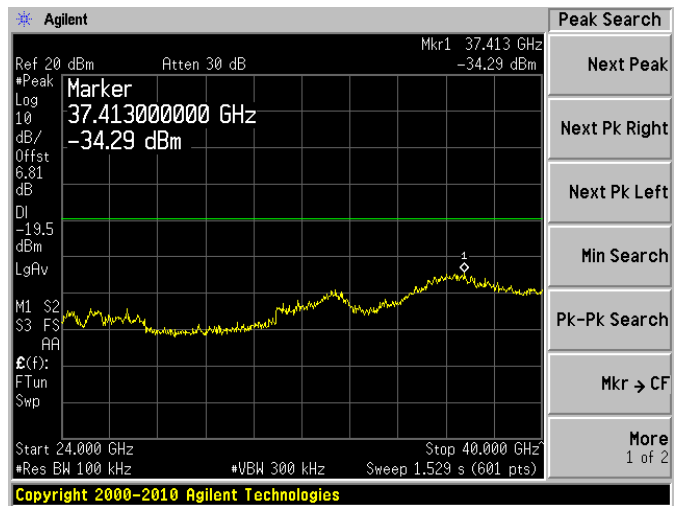
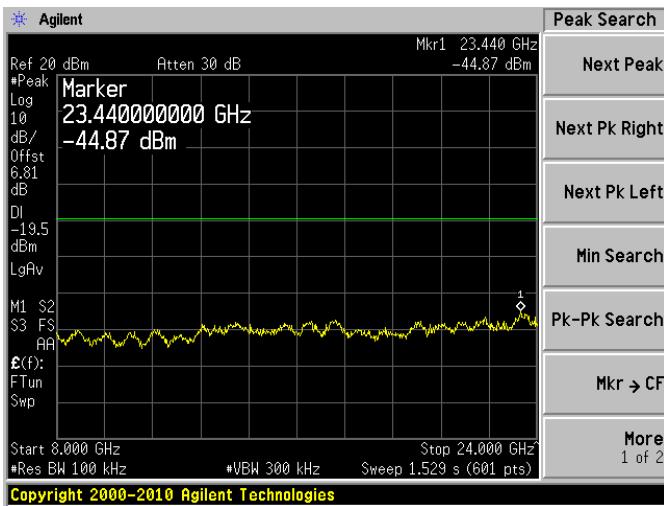

### 5.8 GHz, Antenna #2:

Low Channel

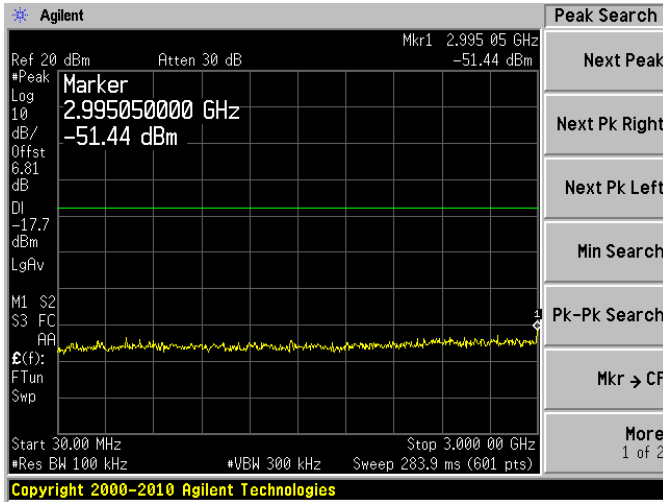

Low Channel

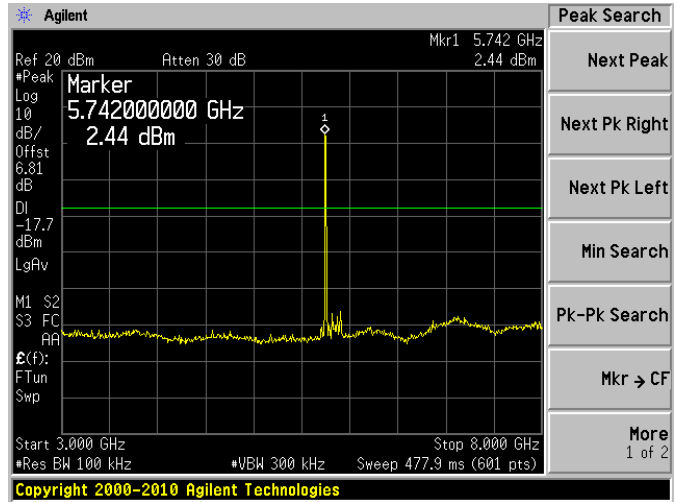

Low Channel

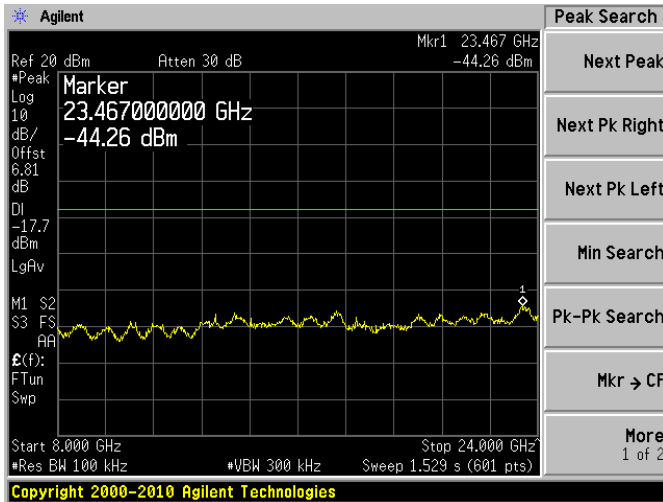

Low Channel



Middle Channel

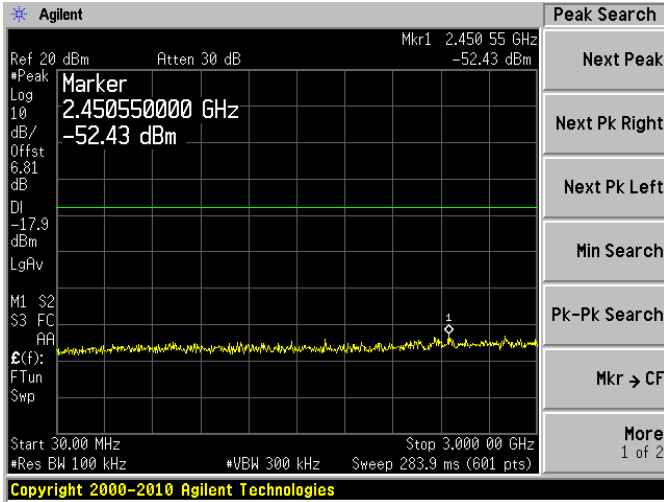

Middle Channel

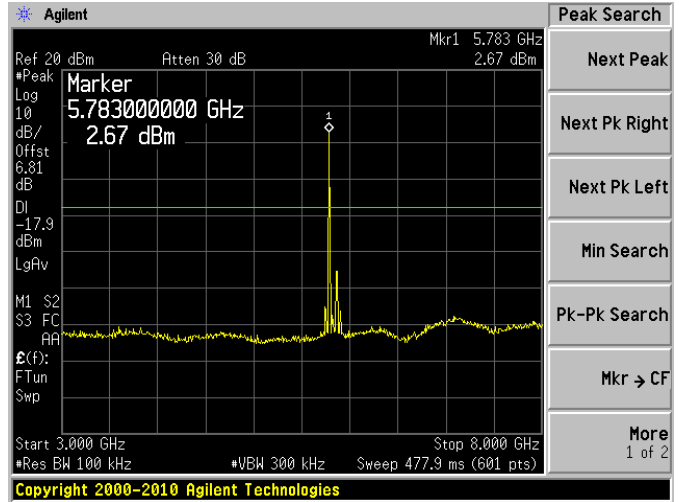

Middle Channel

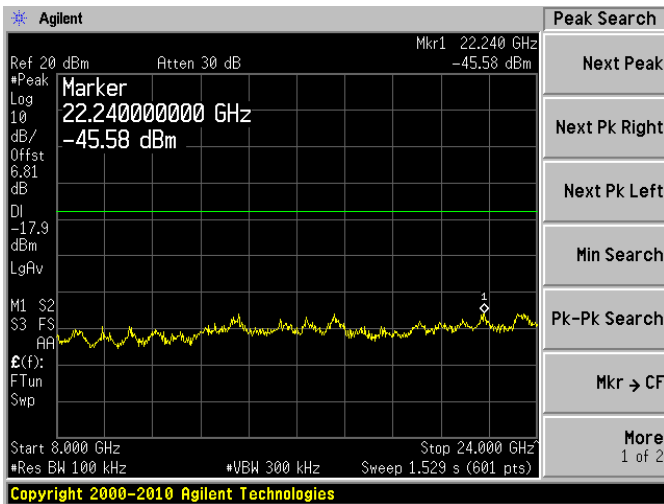

Middle Channel



High Channel

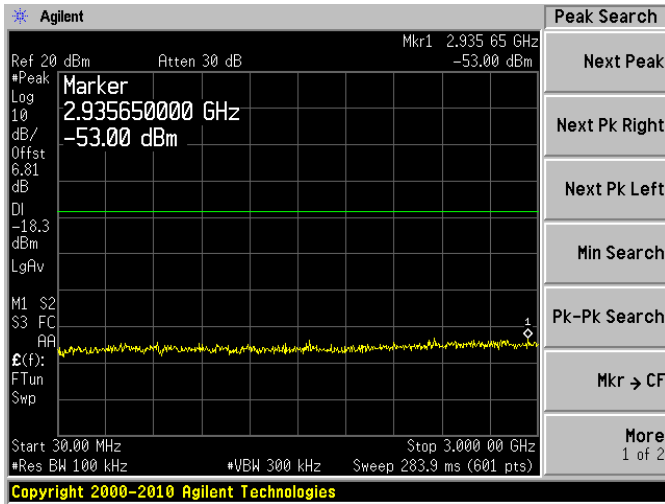

High Channel

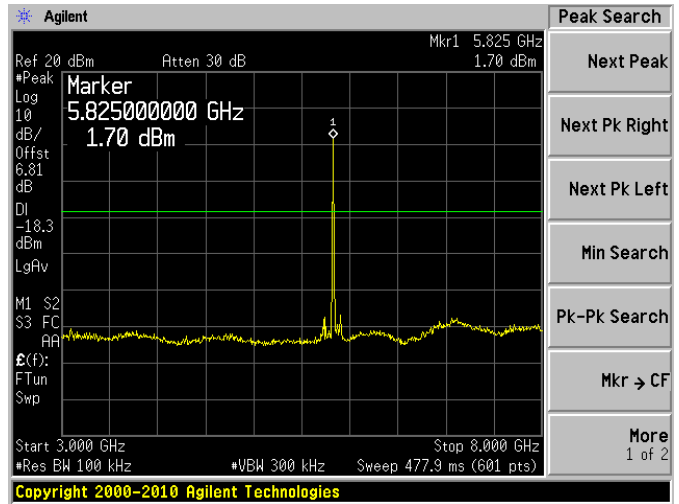

High Channel

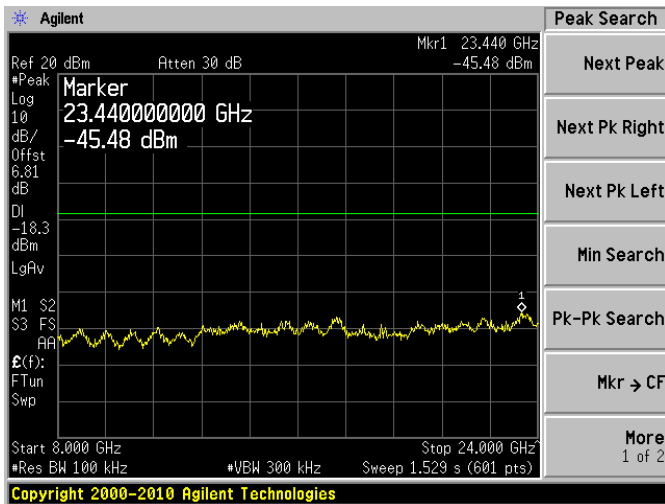

High Channel





5.8 GHz, Antenna #3:

Low Channel

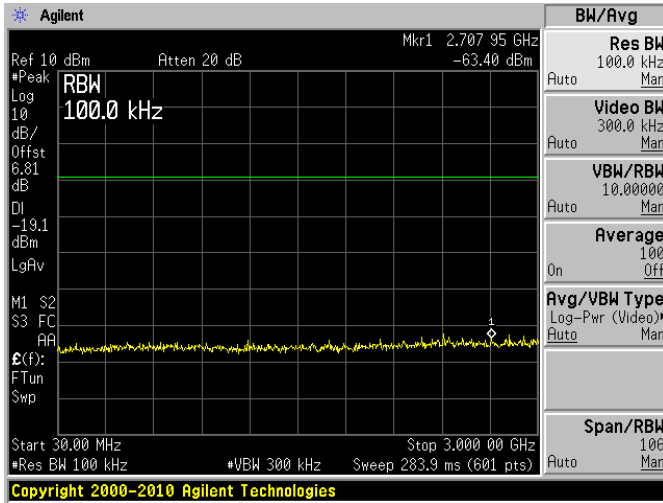

Low Channel

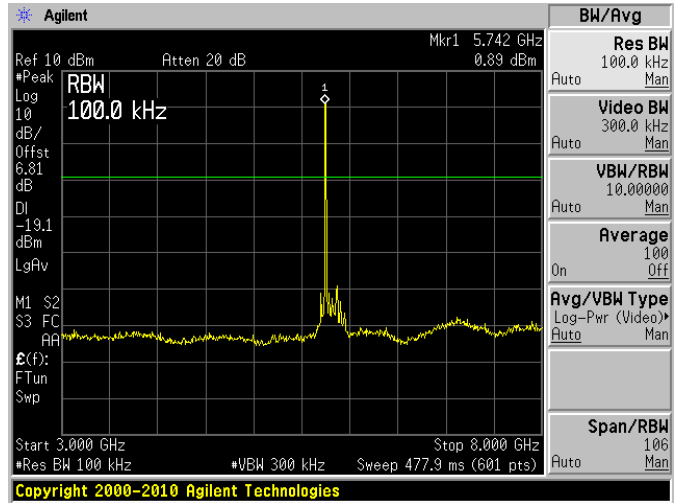

Low Channel

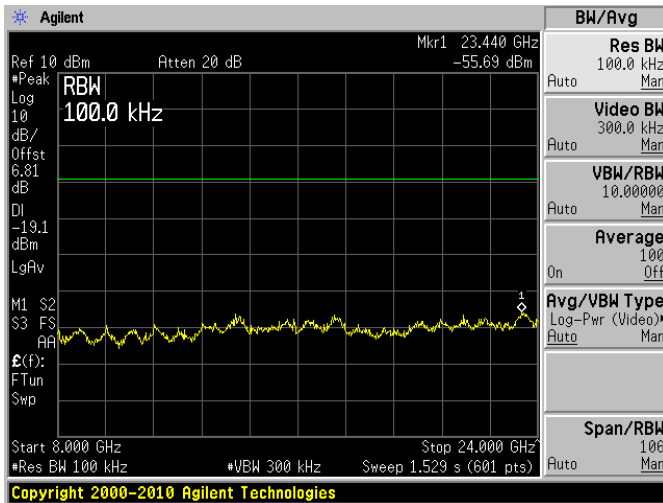

Low Channel

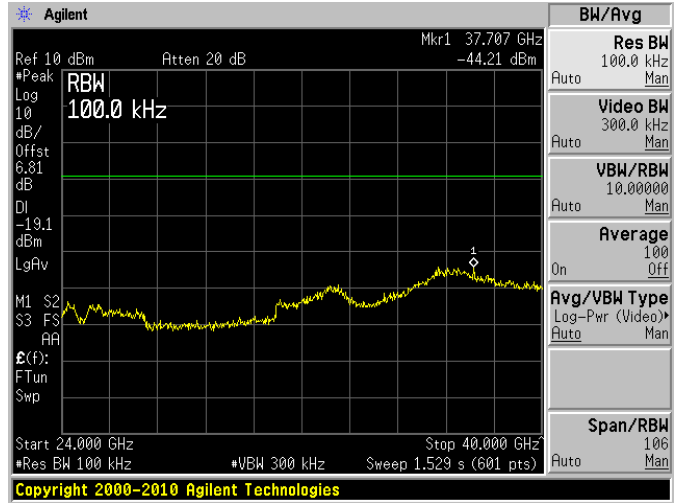

Middle Channel

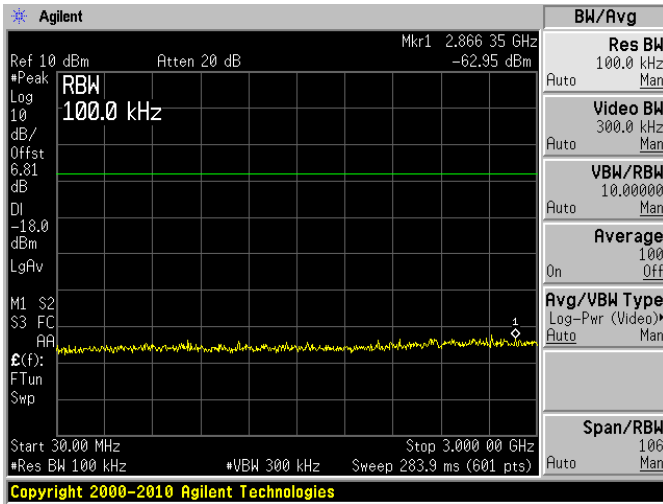

Middle Channel

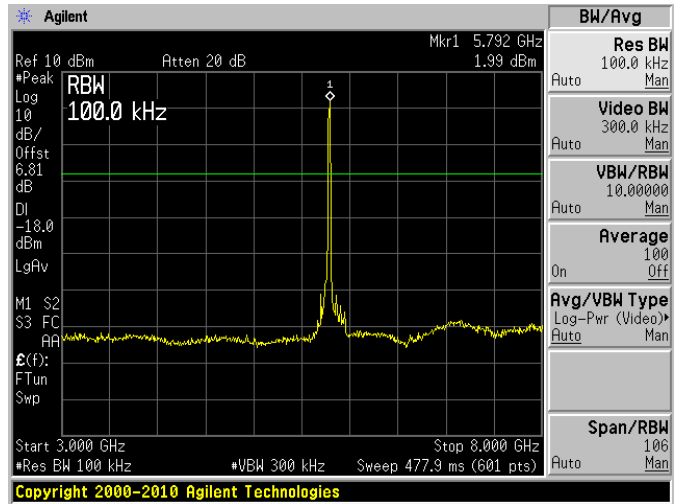

Middle Channel

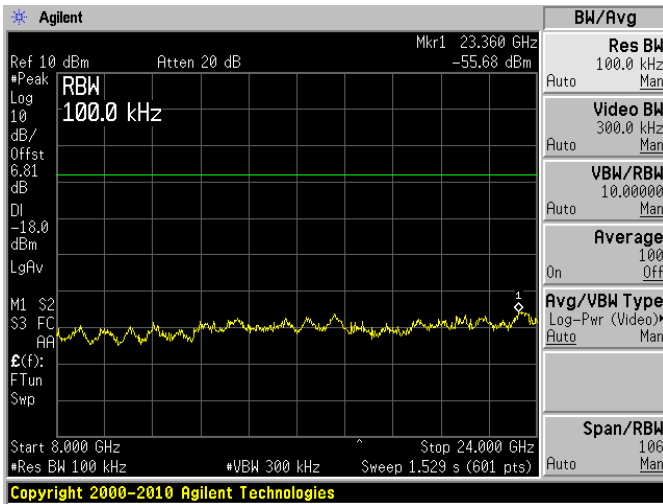

Middle Channel

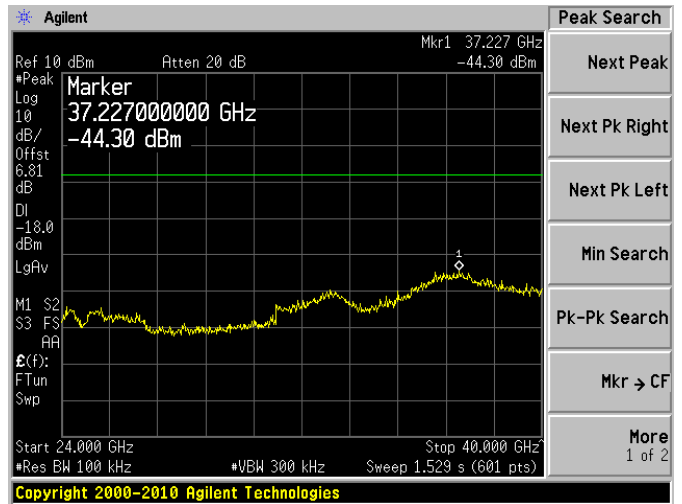

High Channel

High Channel

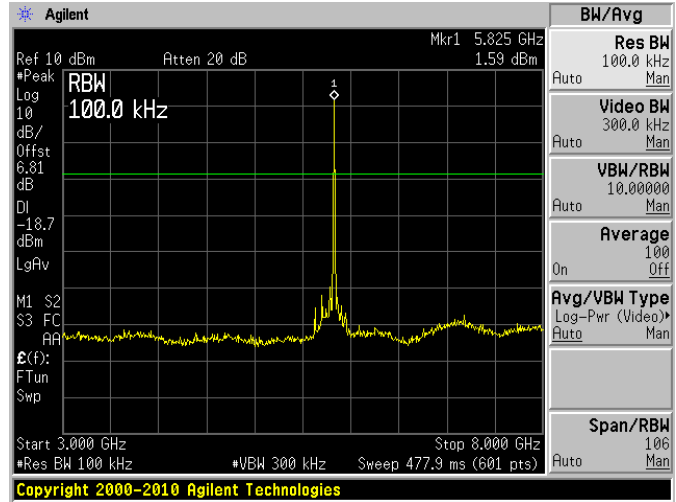
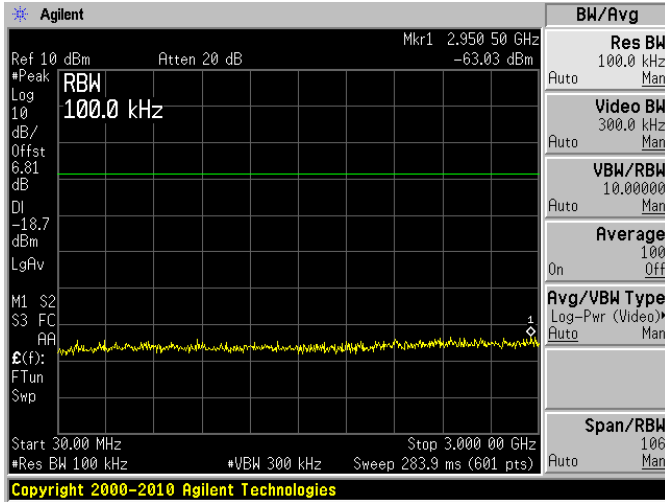

High Channel

High Channel

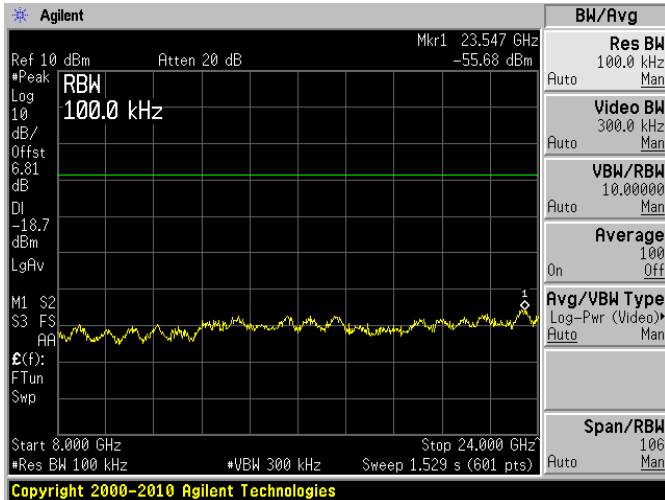

### 5.8 GHz, Antenna #4:

Low Channel

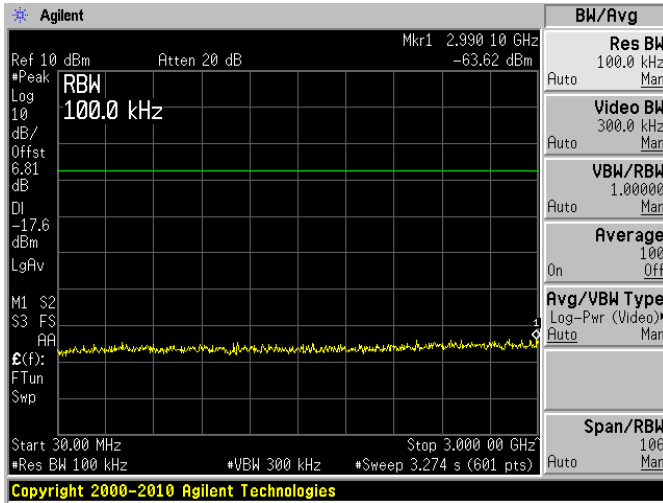

Low Channel

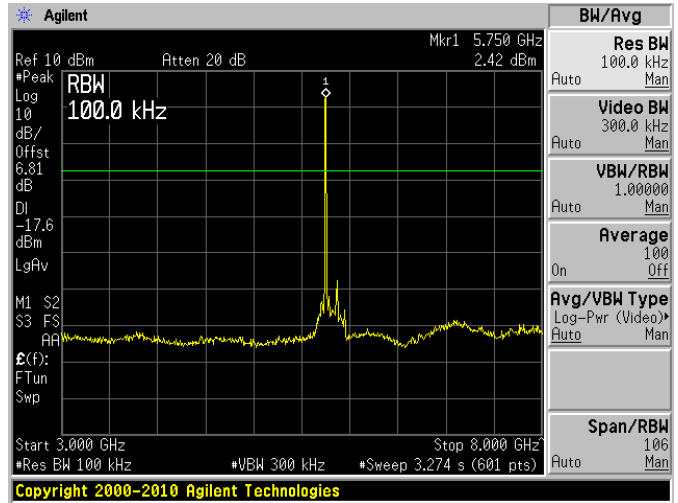

Low Channel

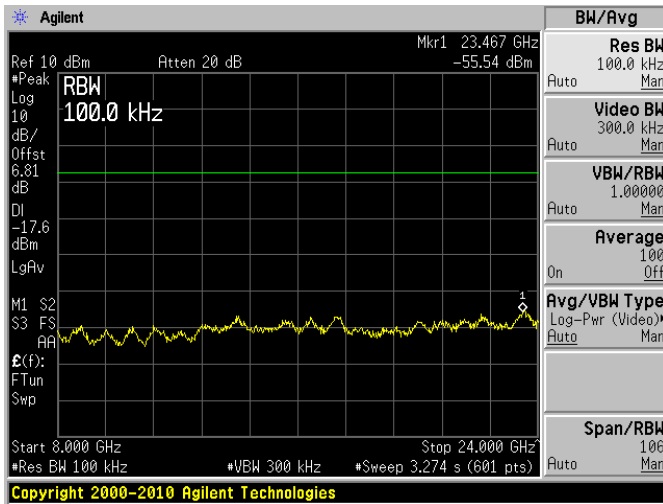

Low Channel



Middle Channel

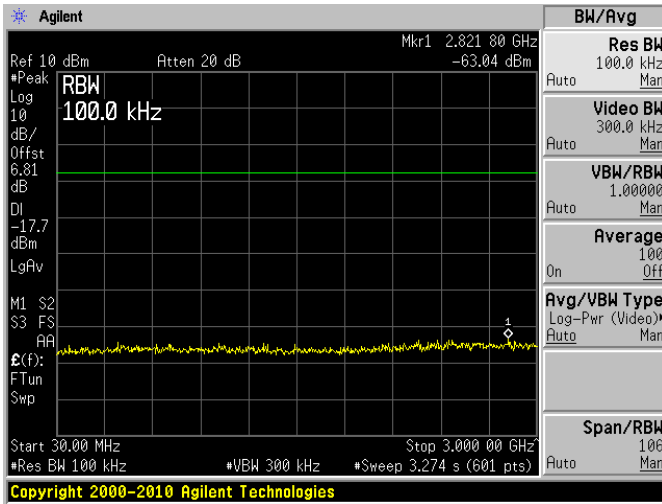

Middle Channel

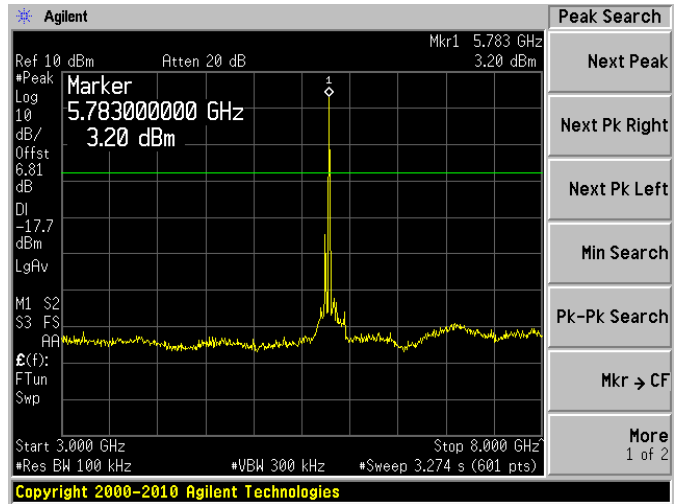

Middle Channel

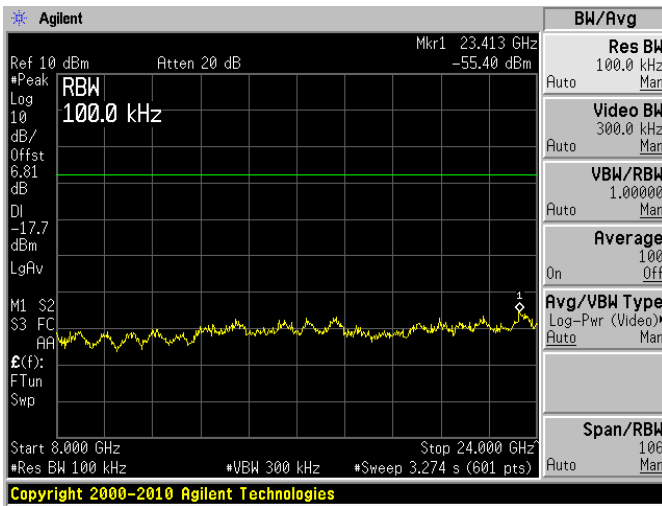

Middle Channel

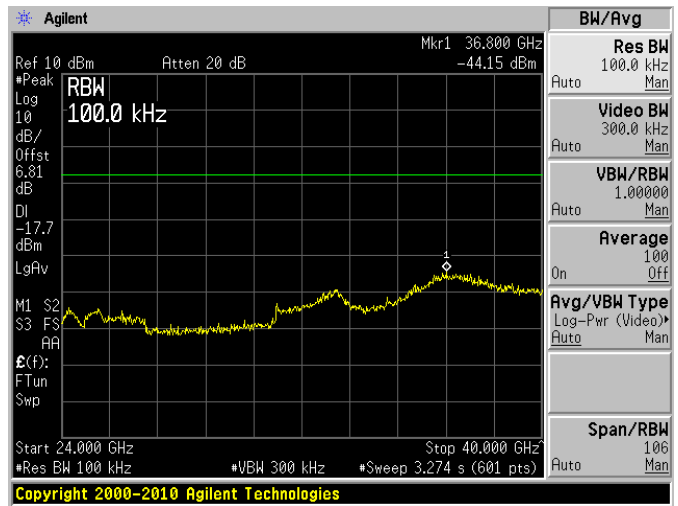

High Channel

High Channel

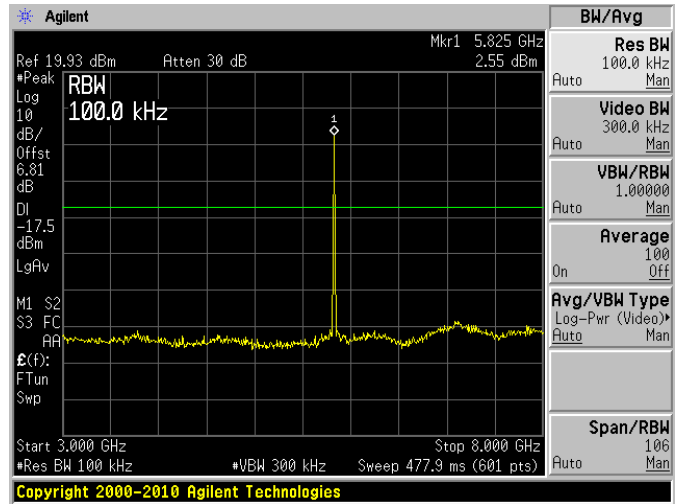
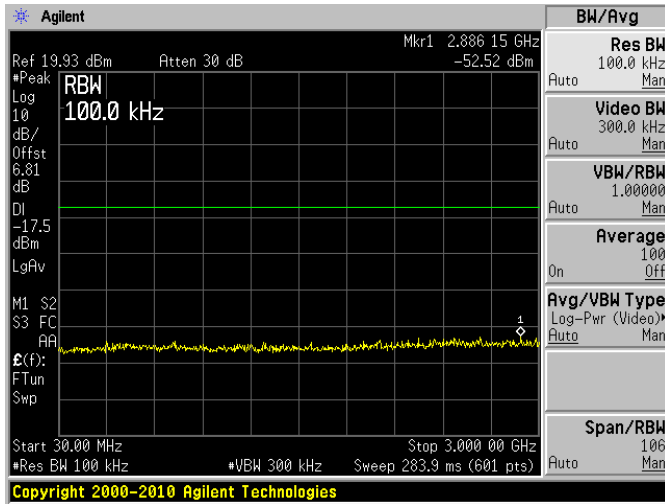

High Channel

High Channel

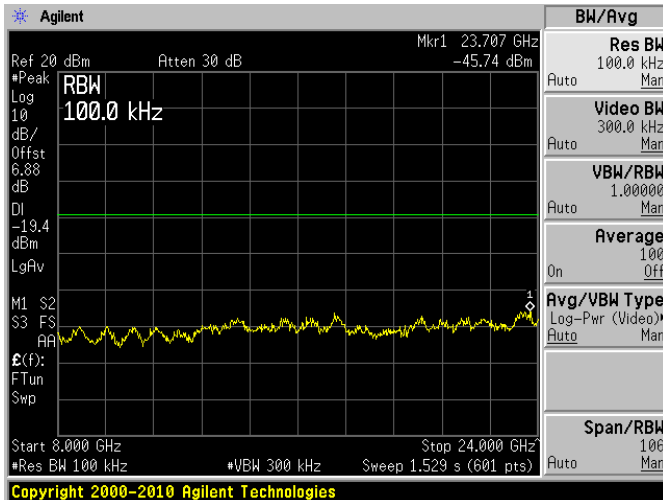

5.8 GHz, Antenna #1 + Antenna #2 + Antenna #3 + Antenna #4:

Low Channel

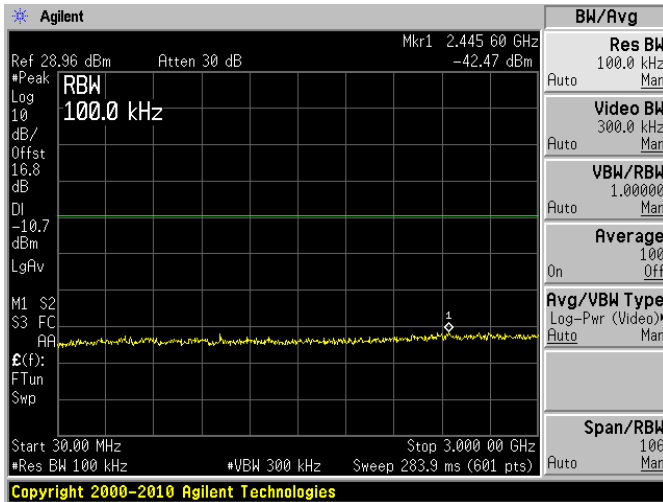

Low Channel

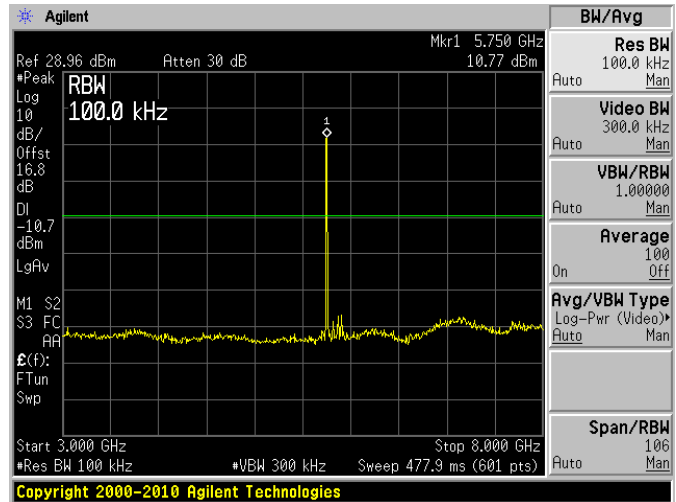

Low Channel

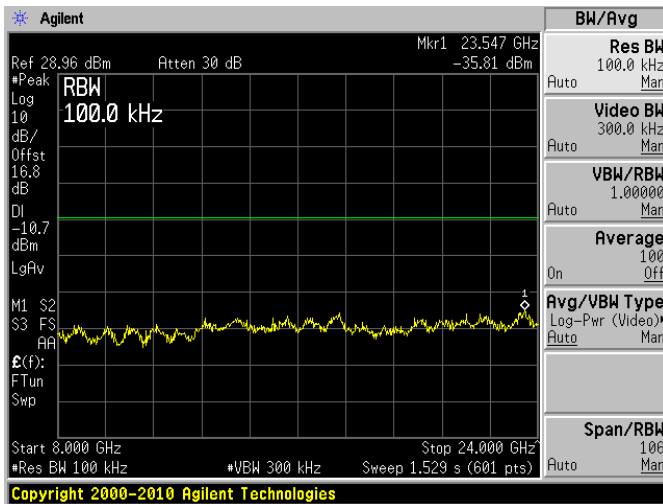

Low Channel



Middle Channel

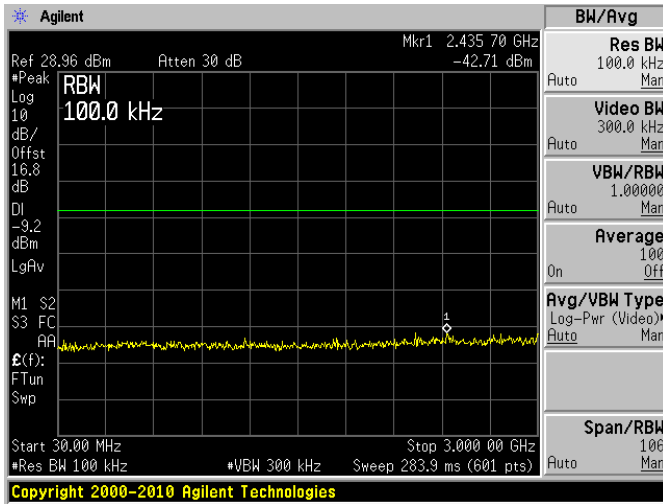

Middle Channel

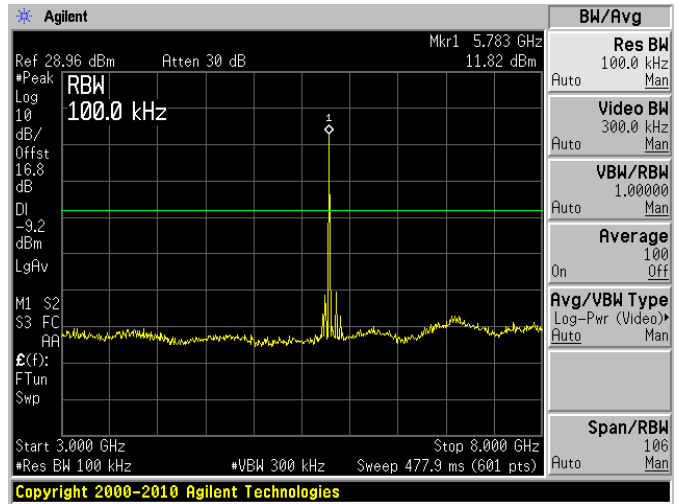

Middle Channel

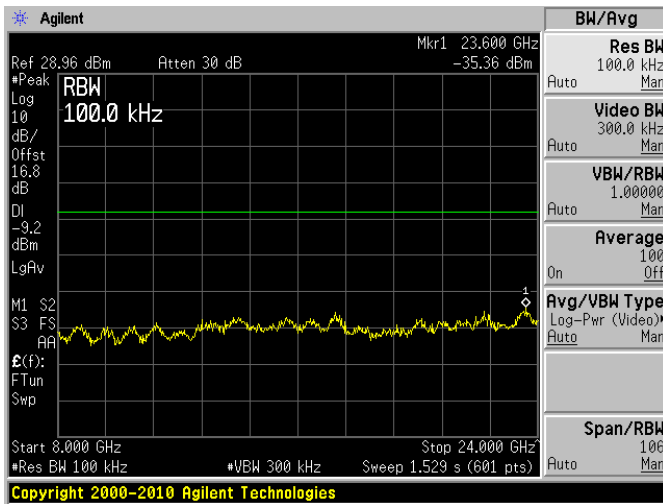

Middle Channel

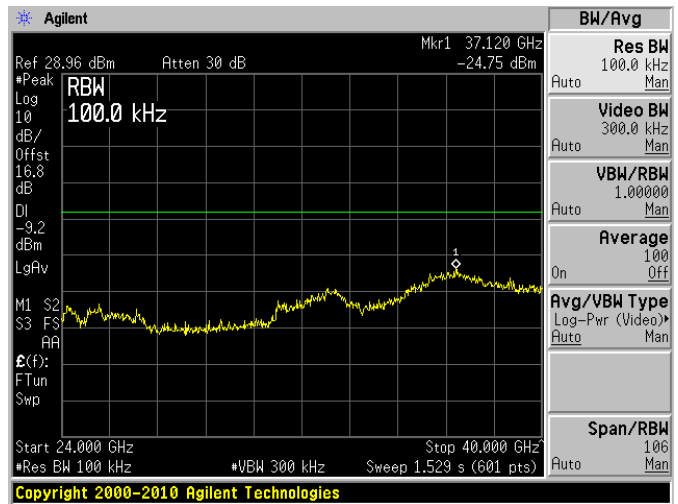



High Channel

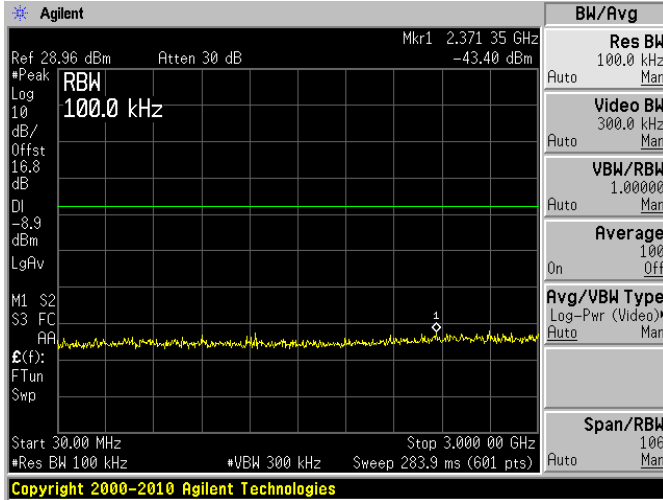

High Channel

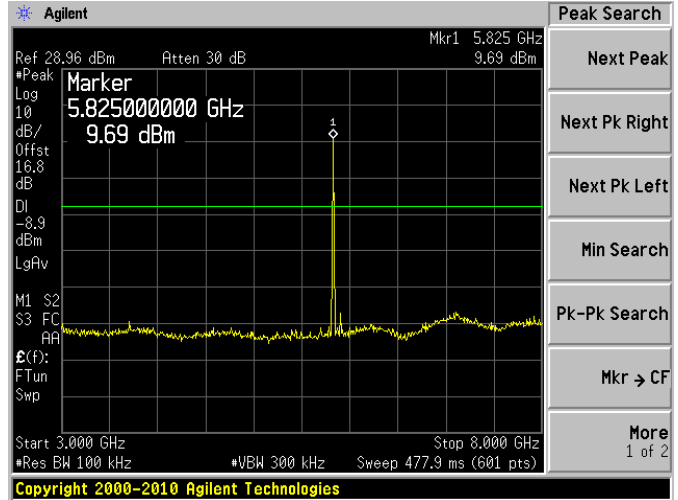

High Channel

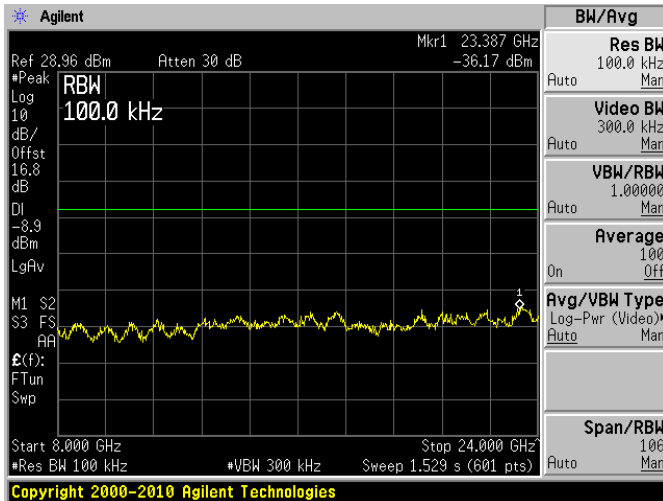

High Channel

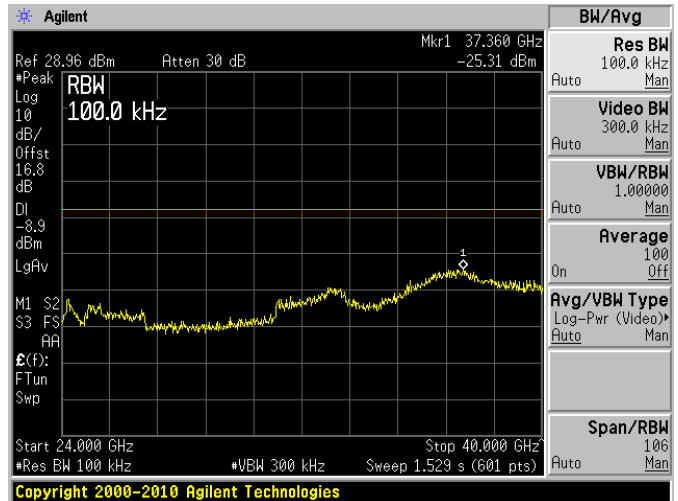

### 5.8 GHz Band (5745–5825 MHz): BPSK with 20MHz bandwidth, EIRP +36 dBm

#### 5.8 GHz, Antenna #1:

Low Channel

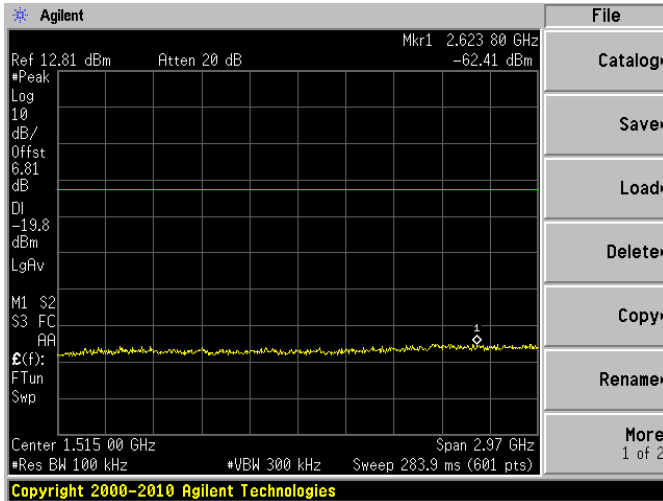

Low Channel

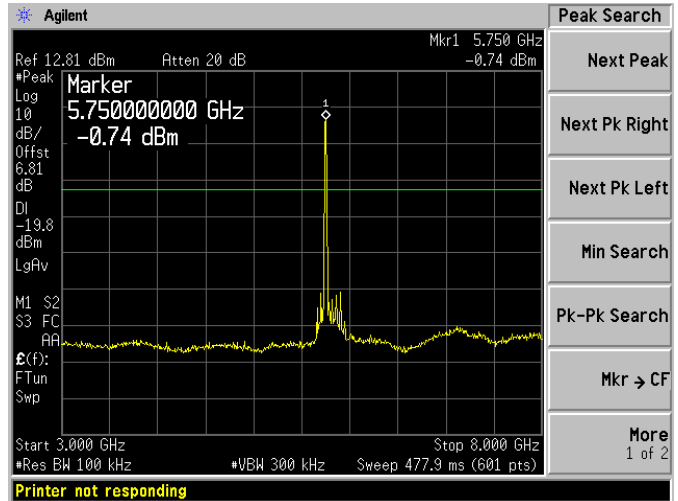

Low Channel

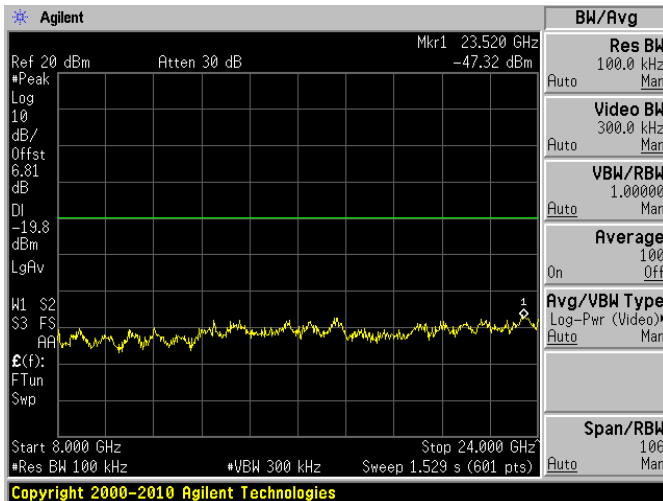

Low Channel

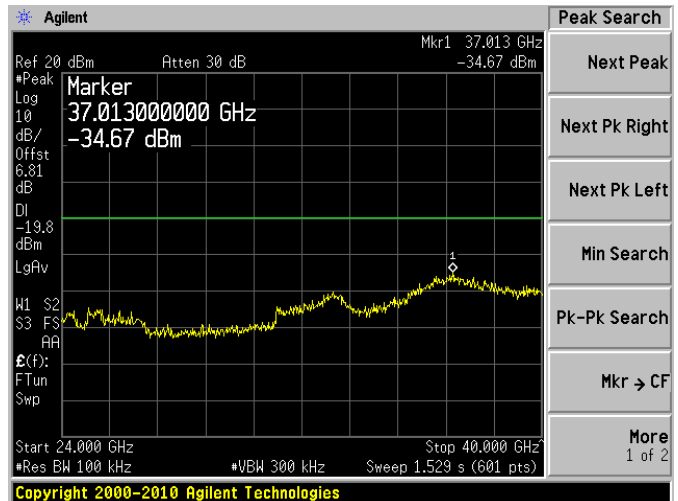

Middle Channel

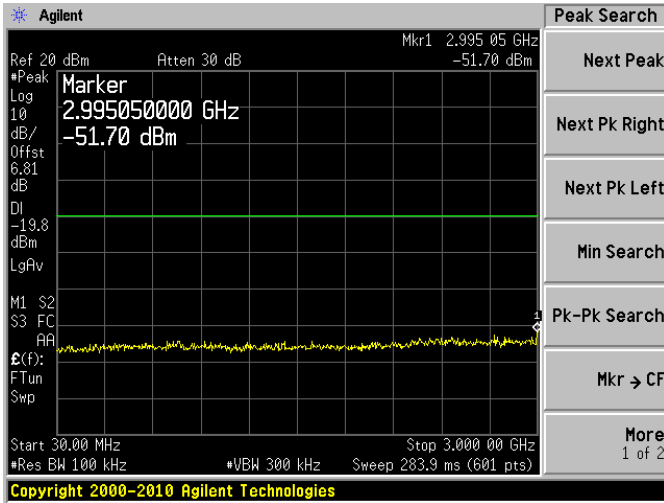

Middle Channel

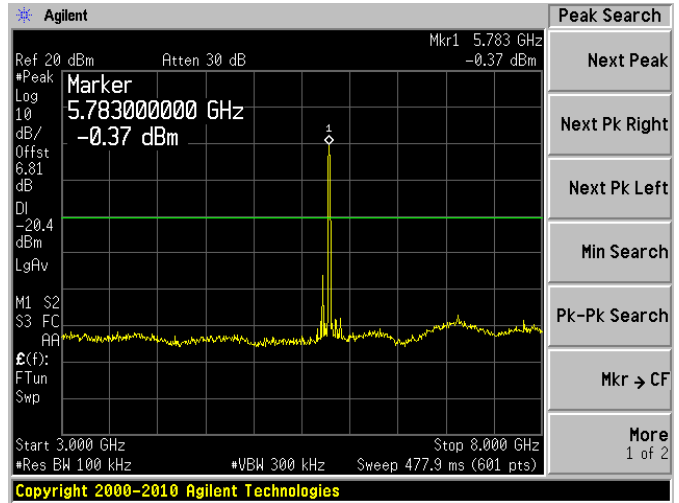

Middle Channel

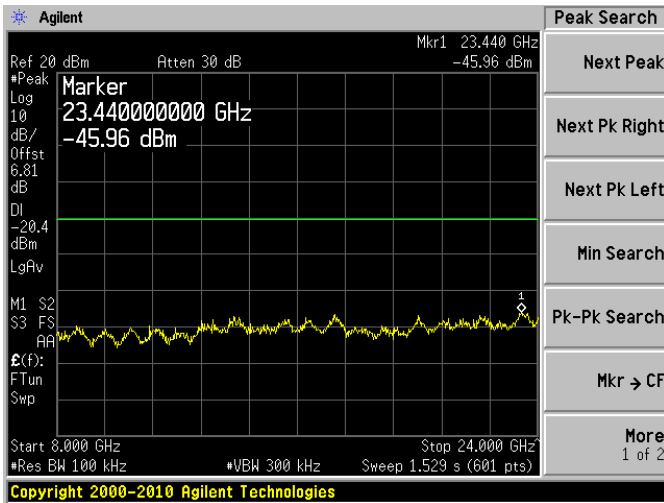

Middle Channel



High Channel

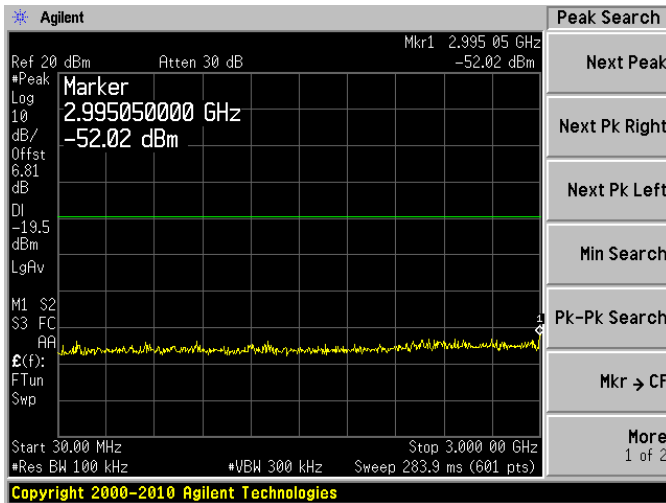

High Channel

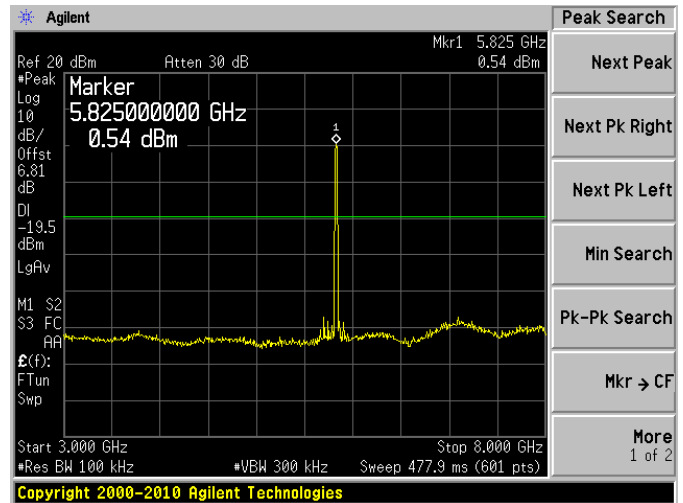

High Channel

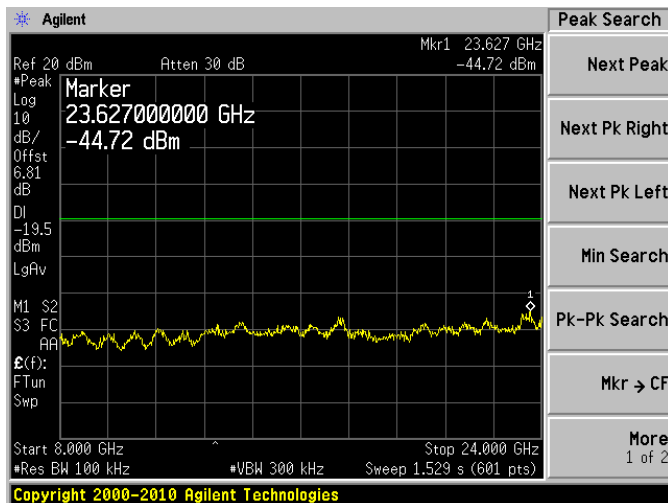

High Channel

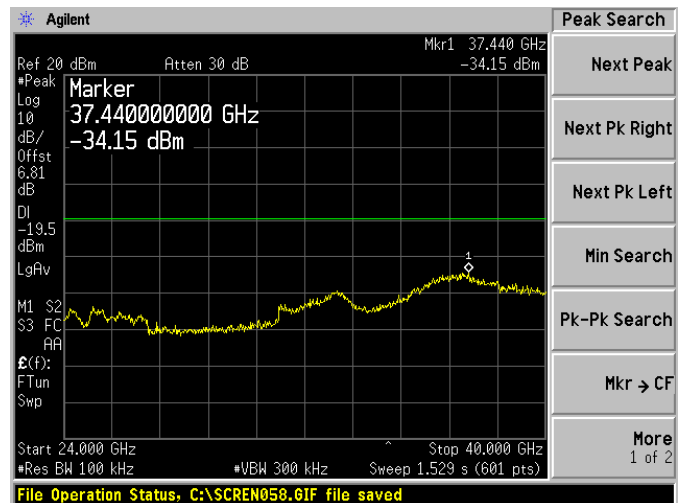

### 5.8 GHz, Antenna #2:

Low Channel

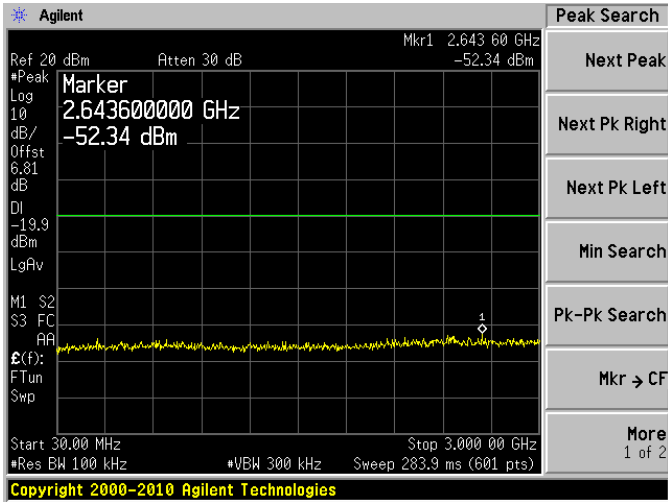

Low Channel

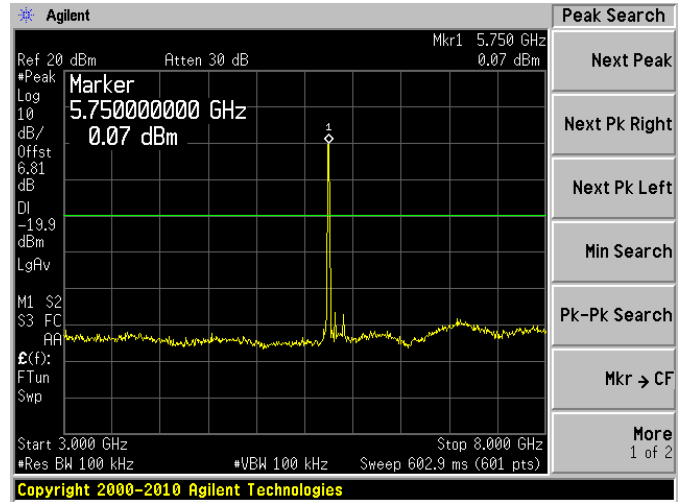

Low Channel

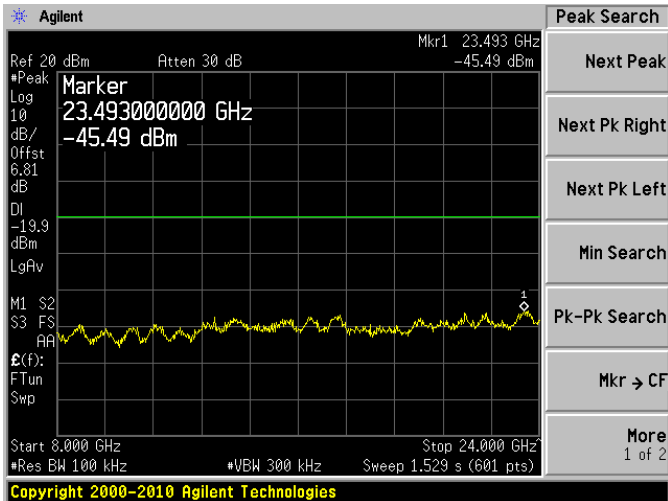

Low Channel



Middle Channel

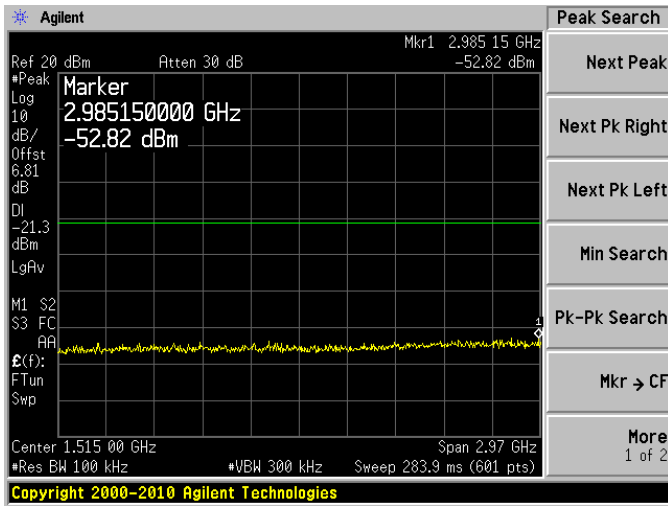

Middle Channel

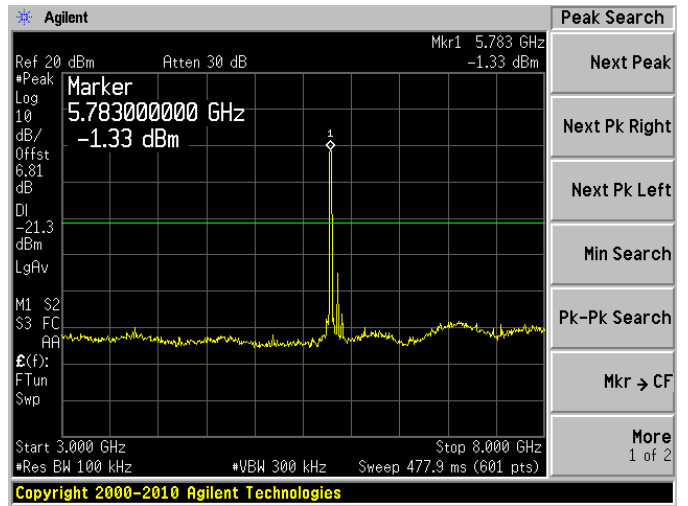

Middle Channel

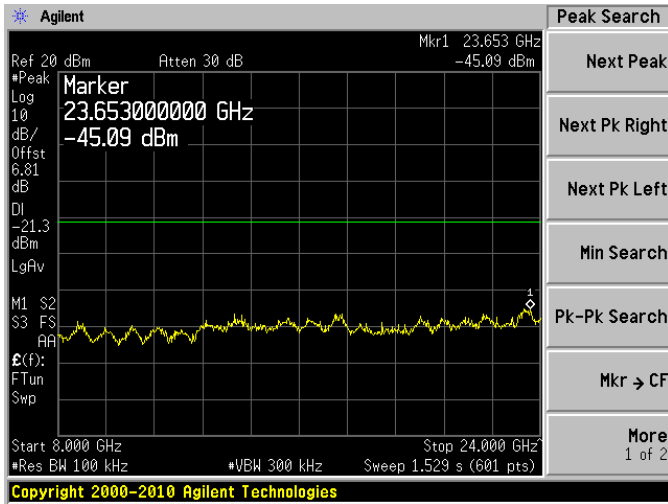

Middle Channel

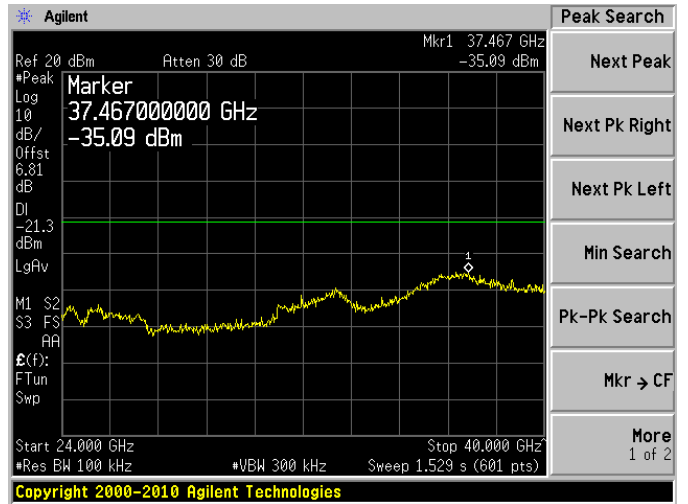

High Channel

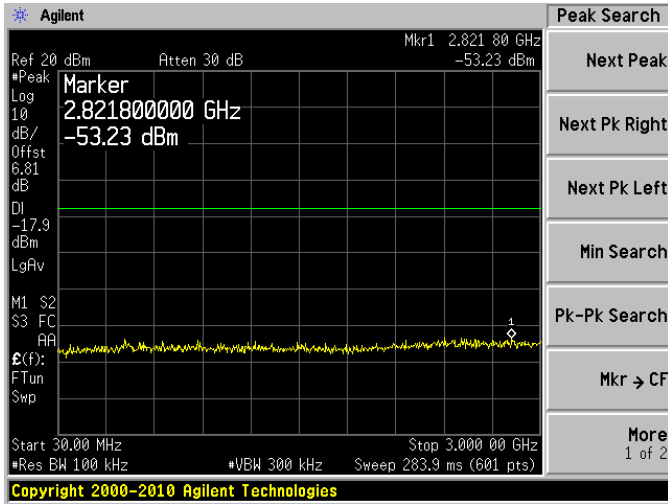

High Channel

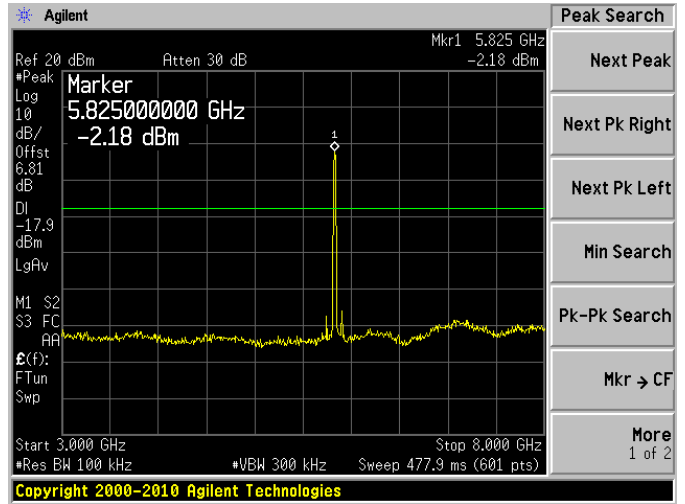

High Channel

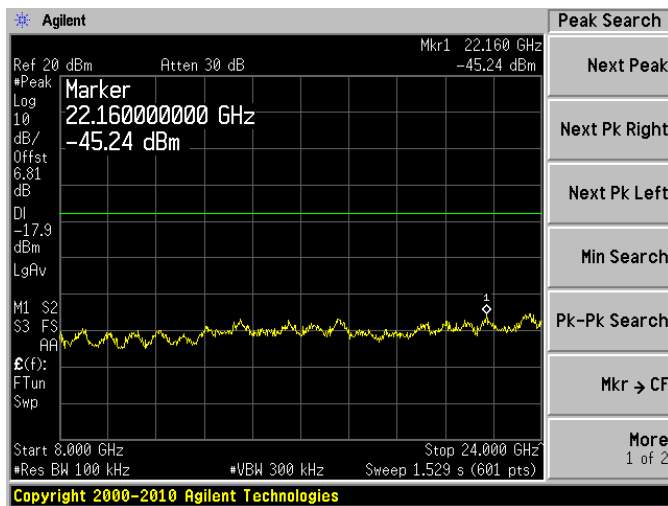

High Channel

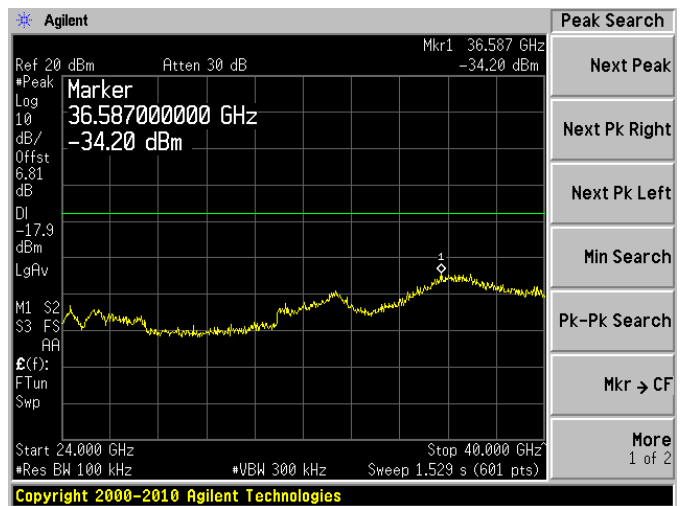

5.8 GHz, Antenna #3:

Low Channel

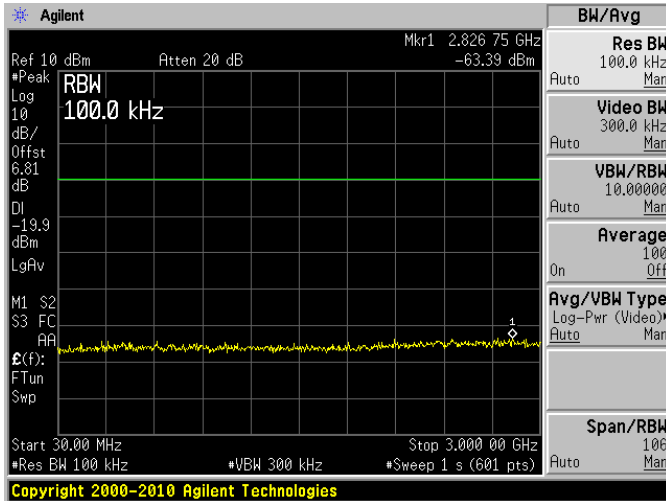

Low Channel

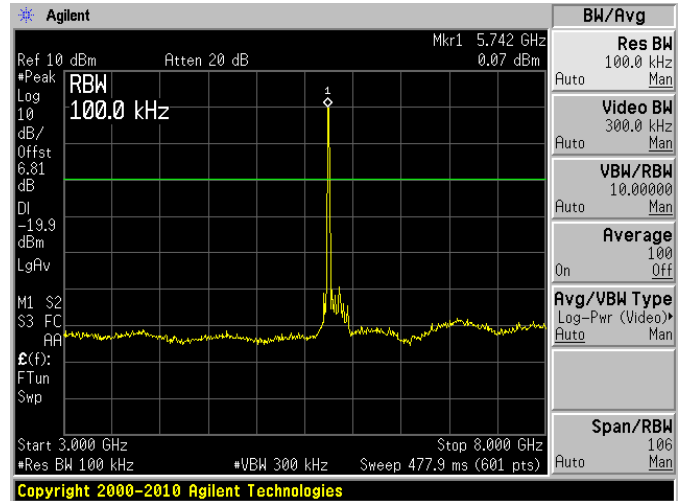

Low Channel

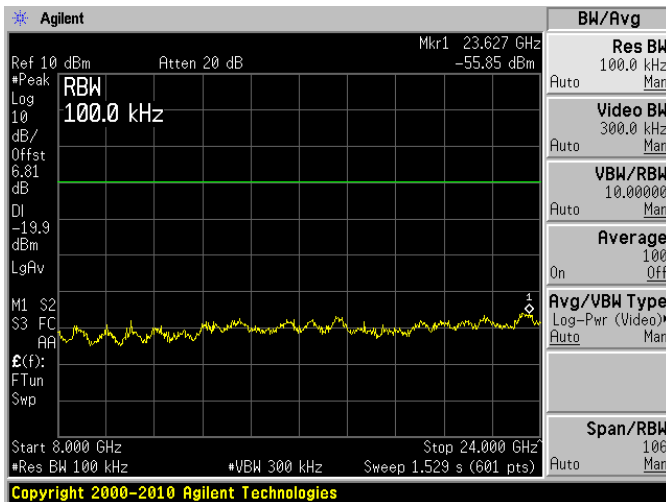

Low Channel

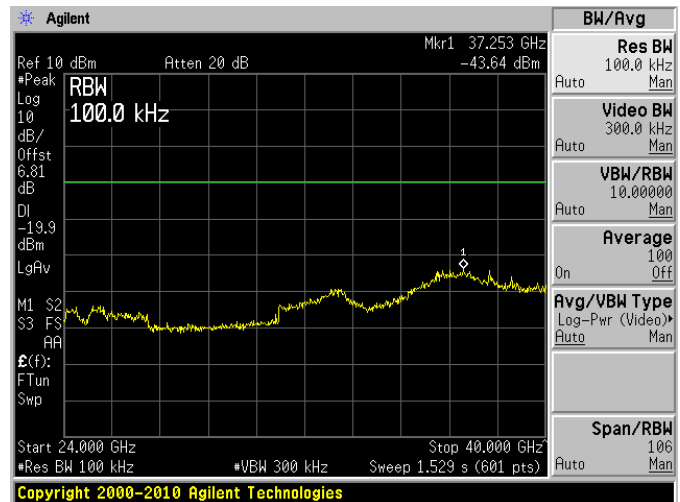



Middle Channel

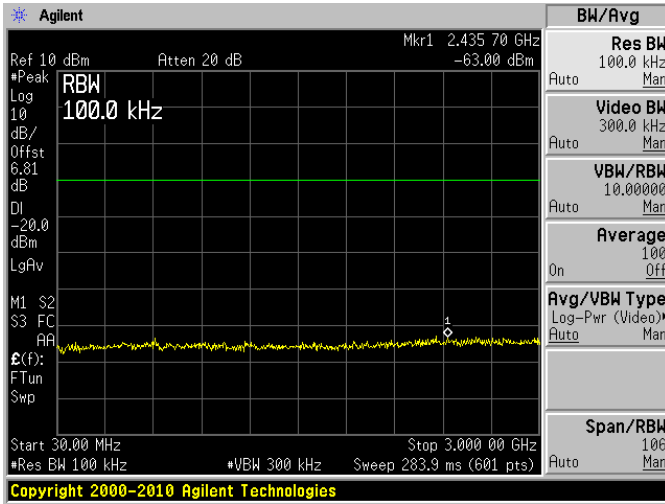

Middle Channel

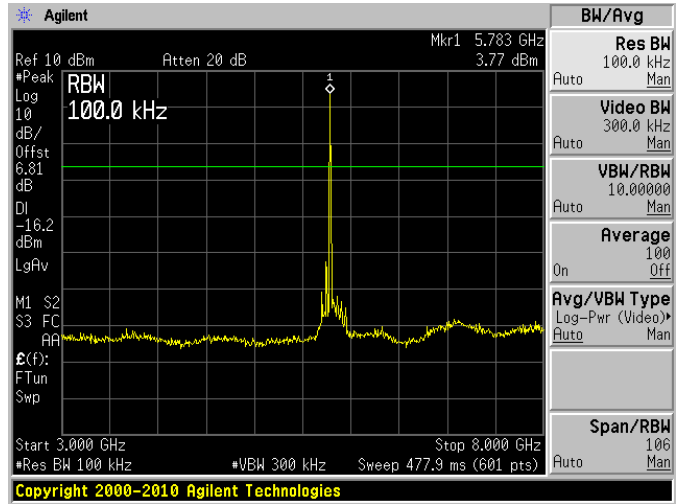

Middle Channel

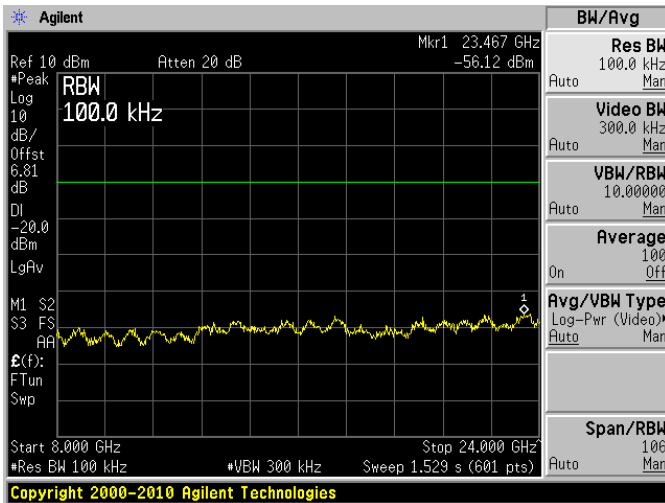

Middle Channel

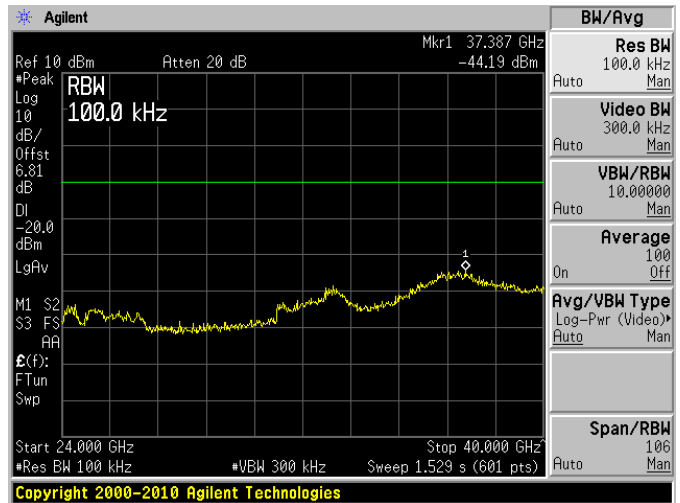

High Channel

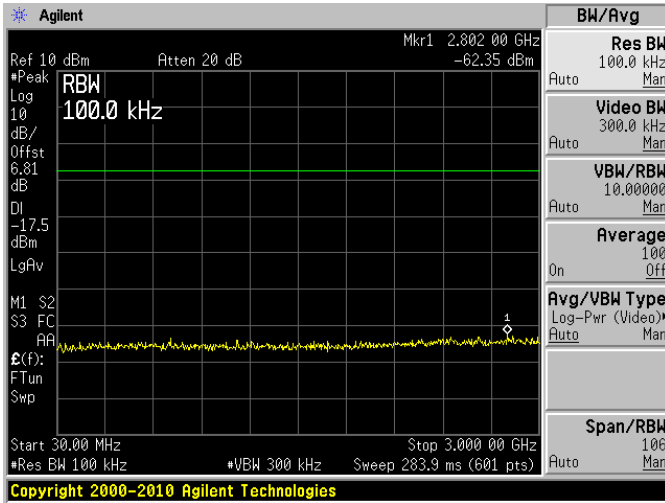

High Channel

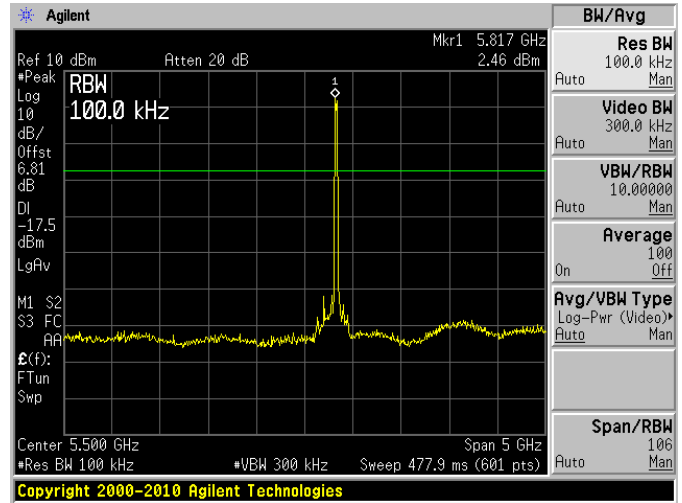

High Channel

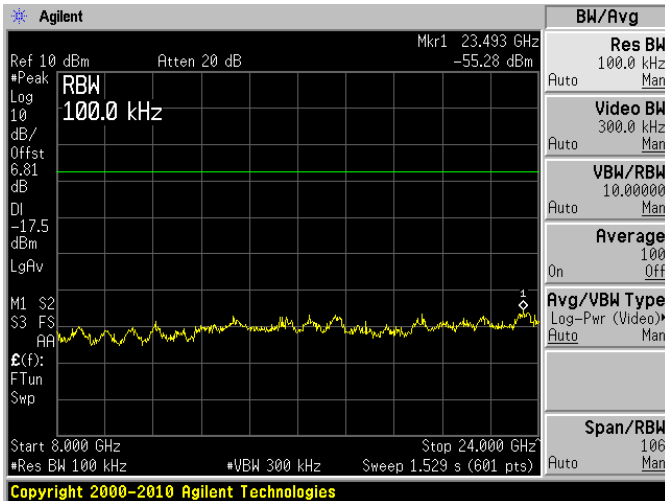

High Channel

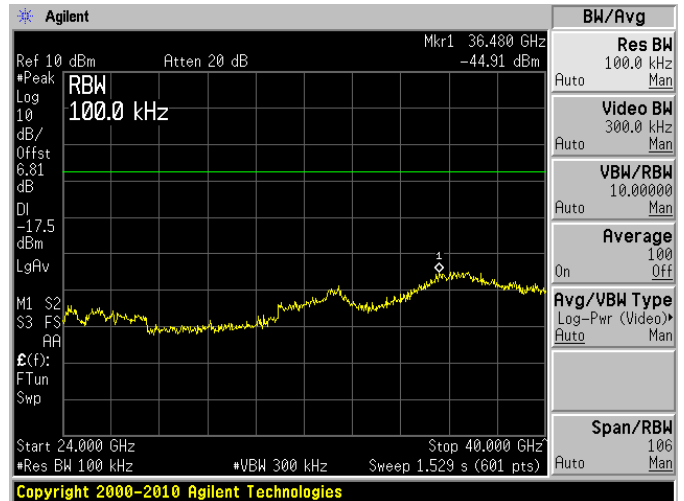

5.8 GHz, Antenna #4:

Low Channel

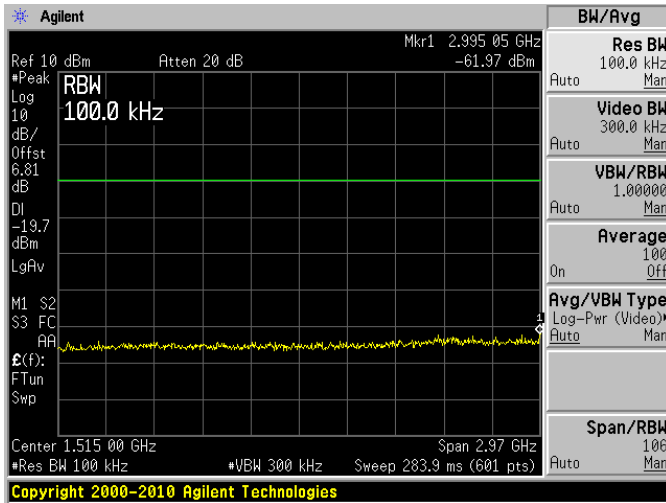

Low Channel

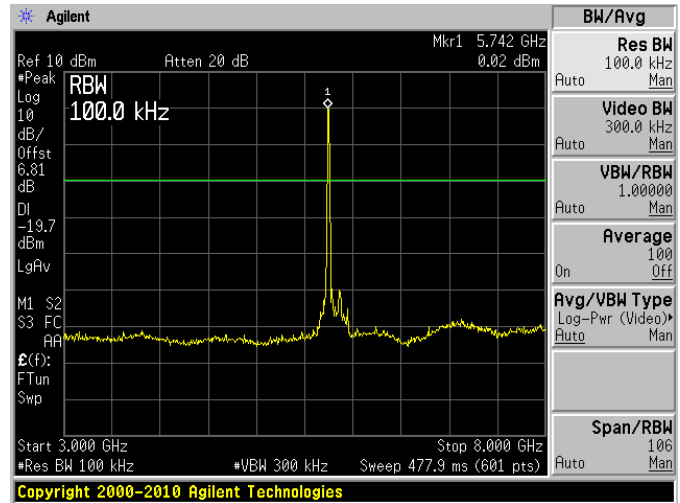

Low Channel

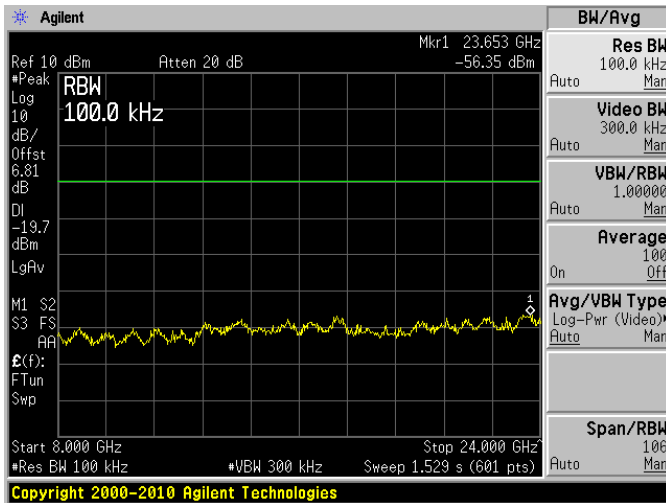

Low Channel



Middle Channel

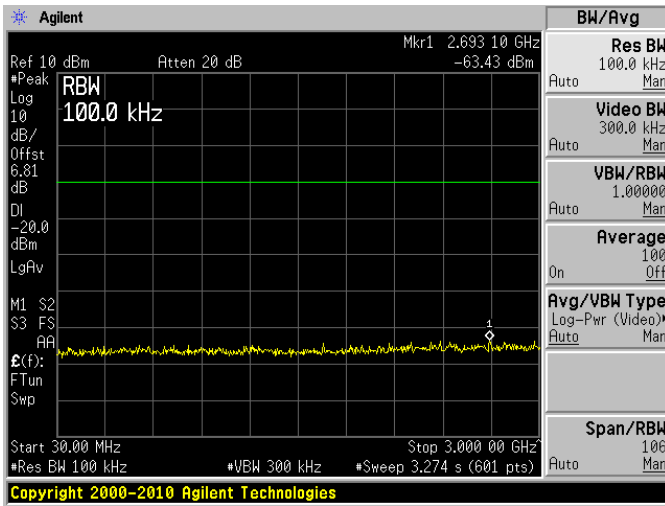

Middle Channel

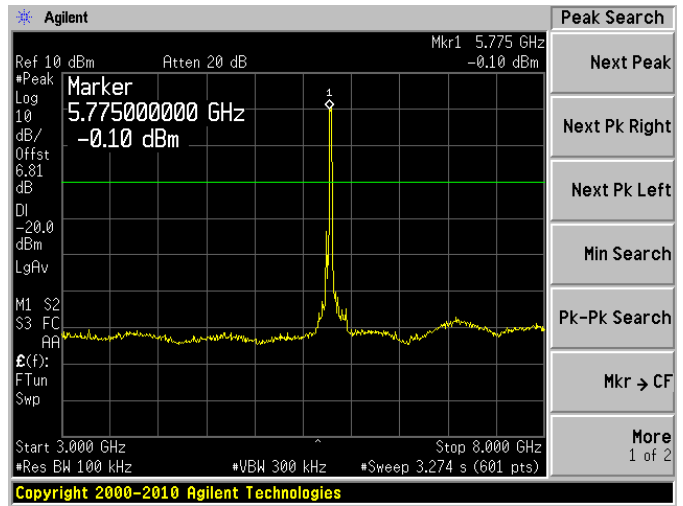

Middle Channel

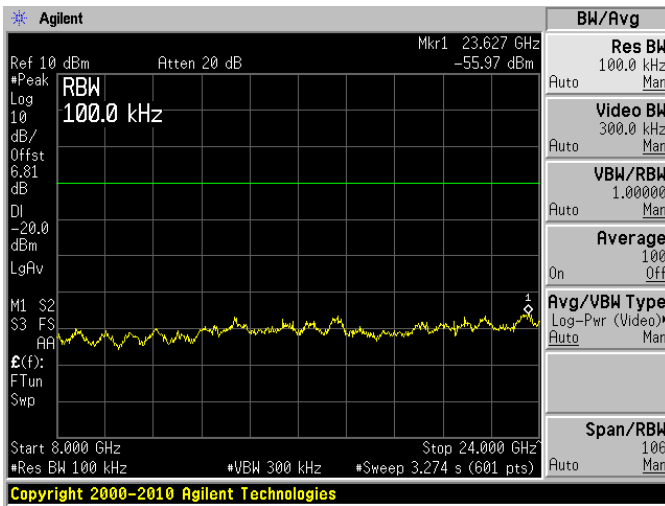

Middle Channel

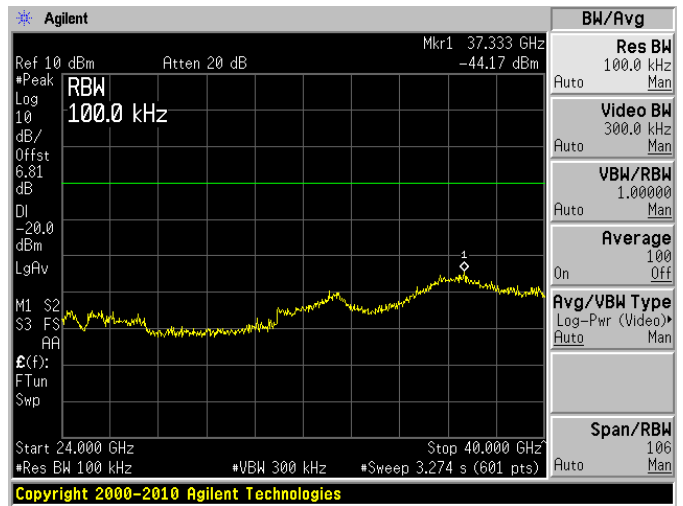

High Channel

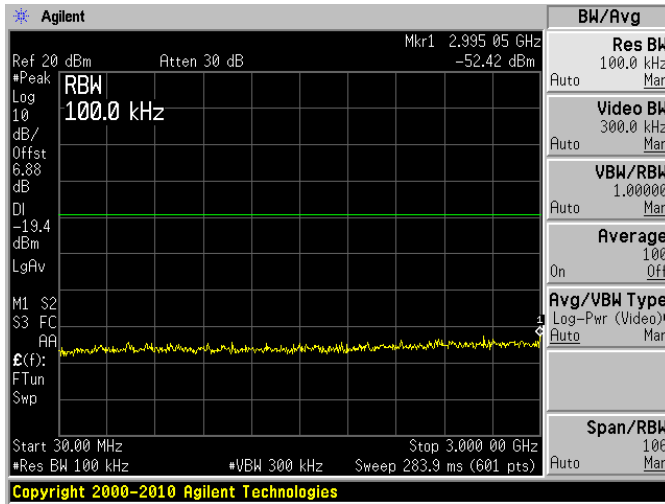

High Channel

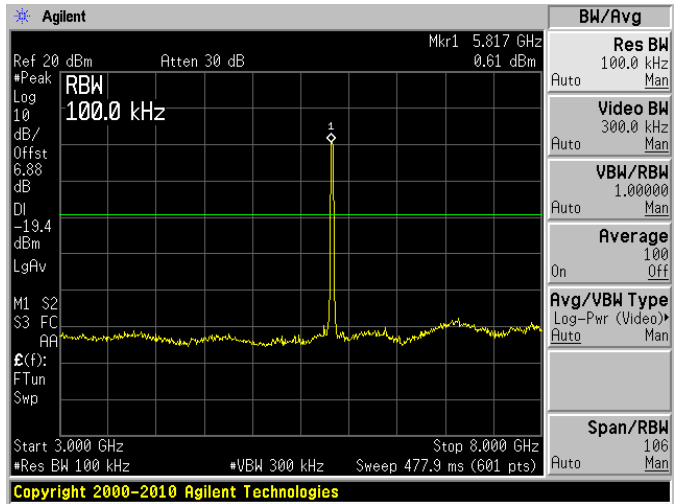

High Channel

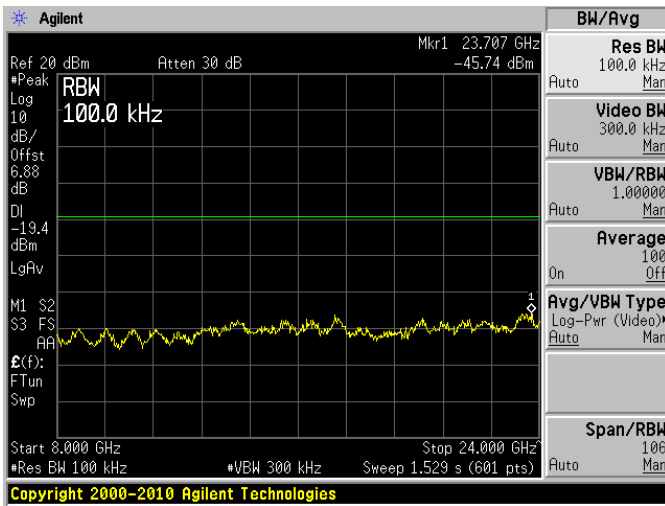

High Channel

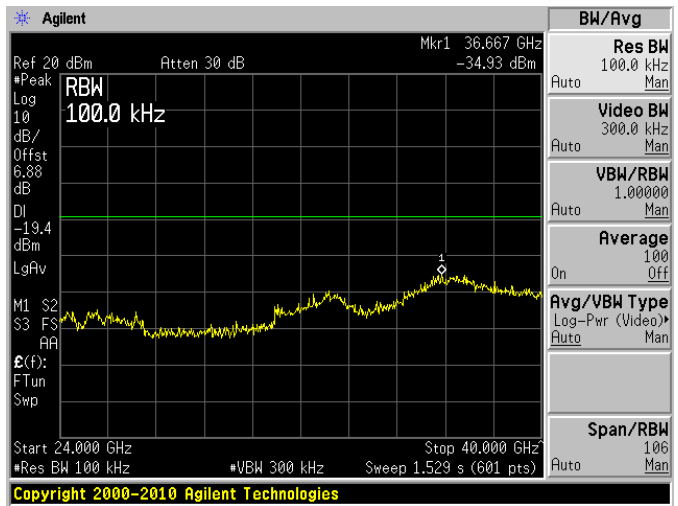

**5.8 GHz, Antenna #1 + Antenna #2 + Antenna #3 + Antenna #4:**

Low Channel

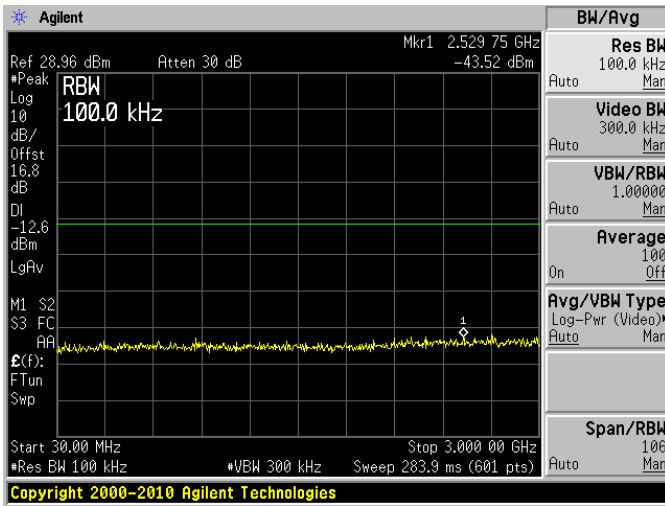

Low Channel

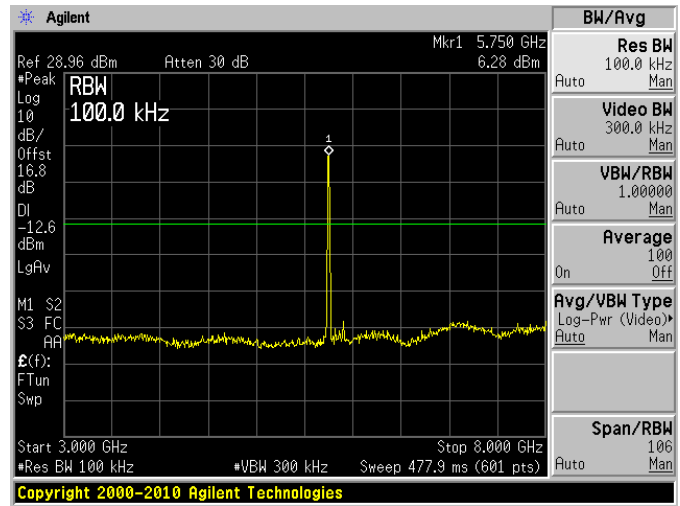

Low Channel

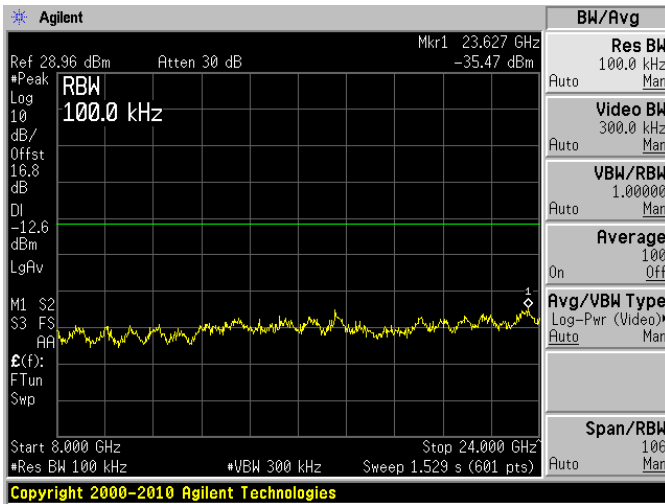

Low Channel



Middle Channel

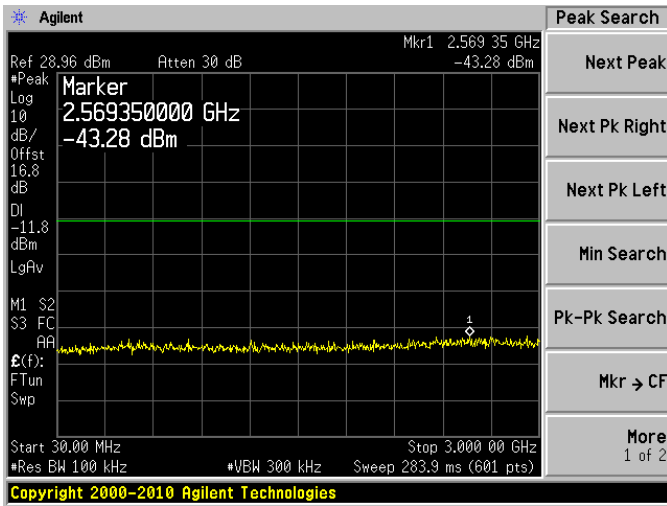

Middle Channel

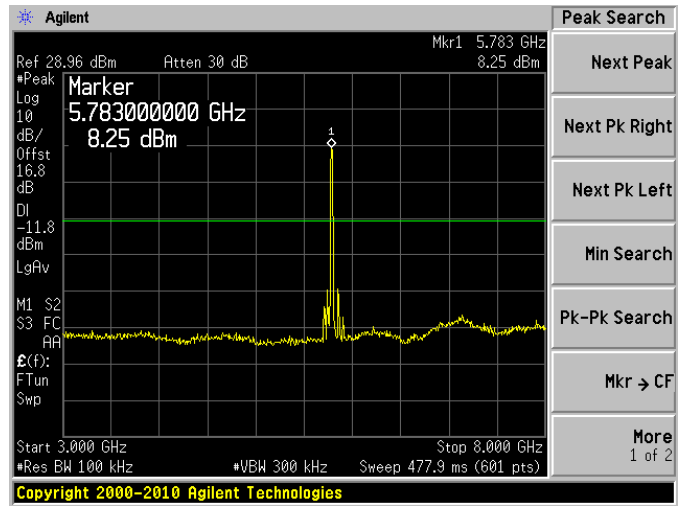

Middle Channel

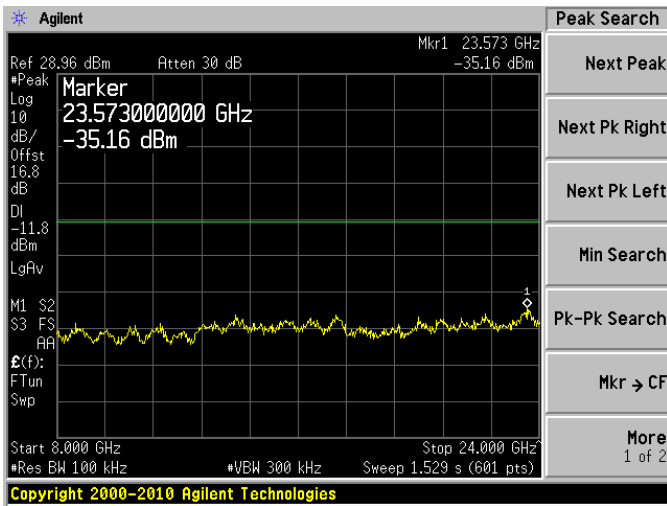

Middle Channel

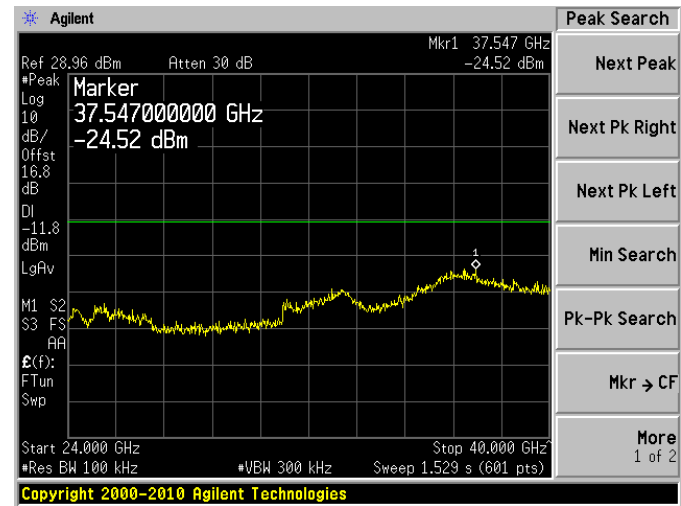

High Channel

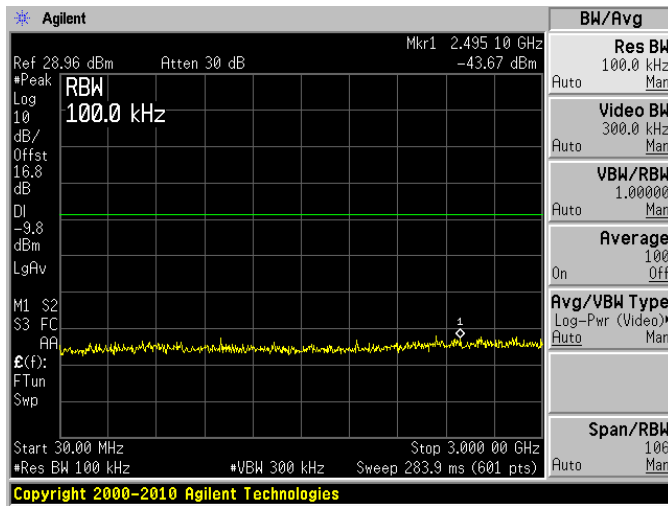

High Channel

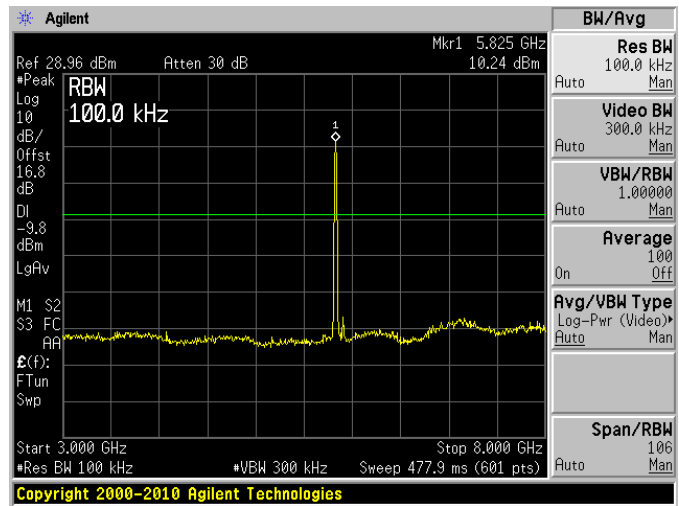

High Channel

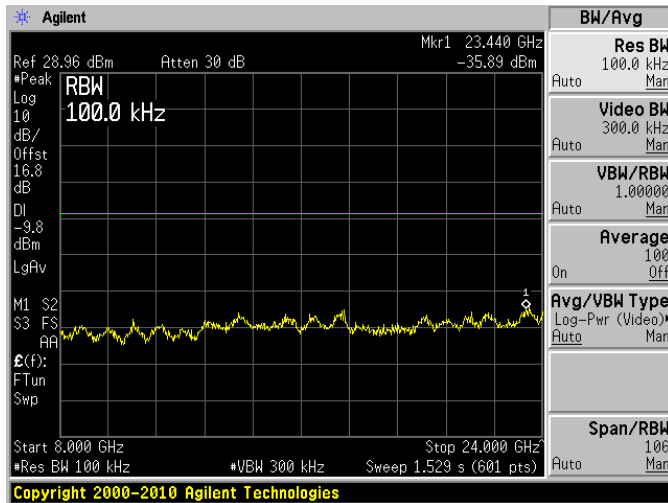

High Channel





## 8 FCC §15.205, §15.209, §15.247(d) & IC RSS-210 §A8.5 – Unwanted Emissions

### 8.1 Applicable Standard

As per FCC §15.35(d): Unless otherwise specified, on any frequency or frequencies above 1000 MHz, the radiated emission limits are based on the use of measurement instrumentation employing an average detector function. Unless otherwise specified, measurements above 1000 MHz shall be performed using a minimum resolution bandwidth of 1 MHz.

As per FCC §15.209(a) and RSS-210: Except as provided elsewhere in this Subpart, the emissions from an intentional radiator shall not exceed the field strength levels specified in the following table

Frequency (MHz)	Field Strength (micro volts/meter)	Measurement Distance (meters)
0.009 - 0.490	2400/F(kHz)	300
0.490 - 1.705	24000/F(kHz)	30
1.705 - 30.0	30	30
30 - 88	100**	3
88 - 216	150**	3
216 - 960	200**	3
Above 960	500	3

\*\* Except as provided in paragraph (g), fundamental emissions from intentional radiators operating under this Section shall not be located in the frequency bands 54-72 MHz, 76-88 MHz, 174-216 MHz or 470-806 MHz. However, operation within these frequency bands is permitted under other sections of this Part, e.g., Sections 15.231 and 15.241.

As Per FCC §15.205(a) except as show in paragraph (d) of this section, only spurious emissions are permitted in any of the frequency bands listed below:

MHz	MHz	MHz	GHz
0.090 – 0.110	16.42 – 16.423	960 – 1240	4.5 – 5.15
0.495 – 0.505	16.69475 – 16.69525	1300 – 1427	5.35 – 5.46
2.1735 – 2.1905	25.5 – 25.67	1435 – 1626.5	7.25 – 7.75
4.125 – 4.128	37.5 – 38.25	1645.5 – 1646.5	8.025 – 8.5
4.17725 – 4.17775	73 – 74.6	1660 – 1710	9.0 – 9.2
4.20725 – 4.20775	74.8 – 75.2	1718.8 – 1722.2	9.3 – 9.5
6.215 – 6.218	108 – 121.94	2200 – 2300	10.6 – 12.7
6.26775 – 6.26825	123 – 138	2310 – 2390	13.25 – 13.4
6.31175 – 6.31225	149.9 – 150.05	2483.5 – 2500	14.47 – 14.5
8.291 – 8.294	156.52475 – 156.52525	2690 – 2900	15.35 – 16.2
8.362 – 8.366	156.7 – 156.9	3260 – 3267	17.7 – 21.4
8.37625 – 8.38675	162.0125 – 167.17	3.332 – 3.339	22.01 – 23.12
8.41425 – 8.41475	167.72 – 173.2	3 3458 – 3 358	23.6 – 24.0
12.29 – 12.293	240 – 285	3.600 – 4.400	31.2 – 31.8
12.51975 – 12.52025	322 – 335.4		36.43 – 36.5
12.57675 – 12.57725	399.9 – 410		Above 38.6
13.36 – 13.41	608 – 614		

As per FCC §15.247 (d) In any 100 kHz bandwidth outside the frequency band in which the spread spectrum or digitally modulated intentional radiator is operating, the radio frequency power that is produced by the intentional radiator shall be at least 20 dB below that in the 100 kHz bandwidth within the band that contains the highest level of the desired power, based on either an RF conducted or a radiated measurement, provided the transmitter demonstrates compliance with the peak conducted power limits. If the transmitter complies with the

conducted power limits based on the use of RMS averaging over a time interval, as permitted under paragraph (b)(3) of this section, the attenuation required under this paragraph shall be 30 dB instead of 20 dB. Attenuation below the general limits specified in §15.209(a) is not required. In addition, radiated emissions which fall in the restricted bands, as defined in §15.205(a), must also comply with the radiated emission limits specified in §15.209(a) (see §15.205(c)).

## 8.2 EUT and Test Setup

The radiated emissions tests were performed using the setup accordance with the ANSI C63.4-2003. The specification used was the FCC 15C and IC RSS-210/RSS-Gen limits.

The spacing between the peripherals was 10 centimeters.

External I/O cables were draped along the edge of the test table and bundle when necessary.

## 8.3 Test Procedure

For the radiated emissions test, the EUT host, and all support equipment power cords was connected to the AC floor outlet.

Maximizing procedure was performed on the highest emissions to ensure that the EUT complied with all installation combinations.

The EUT is set 3 meter away from the testing antenna, which is varied from 1-4 meter, and the EUT is placed on a turntable, which is 0.8 meter above ground plane, the table shall be rotated for 360 degrees to find out the highest emission. The receiving antenna should be changed the polarization both of horizontal and vertical.

The spectrum analyzer or receiver is set as:

Below 1000 MHz:

$$\text{RBW} = 100 \text{ kHz/VBW} = 300 \text{ kHz/Sweep} = \text{Auto}$$

Above 1000 MHz:

- (1) Peak:  $\text{RBW} = 1\text{MHz/VBW} = 1\text{MHz/Sweep} = \text{Auto}$
- (2) Average:  $\text{RBW} = 1\text{MHz/VBW} = 10\text{Hz/Sweep} = \text{Auto}$

## 8.4 Corrected Amplitude & Margin Calculation

The Corrected Amplitude is calculated by adding the Cable Loss, and Attenuator Factor adding to the Indicated Reading. The basic equation is as follows:

$$\text{Corrected Amplitude} = \text{Indicated Reading} + \text{Cable Loss} + \text{Attenuator Factor}$$

For example, a Corrected Amplitude of 34.08 dBuV/m = Indicated Reading (23.85 dBuV) + Cable Factor (0.22 dB) + Attenuator Factor (10dB)

The “**Margin**” column of the following data tables indicates the degree of compliance within the applicable limit. For example, a margin of -7 dB means the emission is 7 dB below the maximum limit. The equation for margin calculation is as follows:

$$\text{Margin} = \text{Corrected Amplitude} - \text{Limit}$$

## 8.5 Test Setup Block Diagram

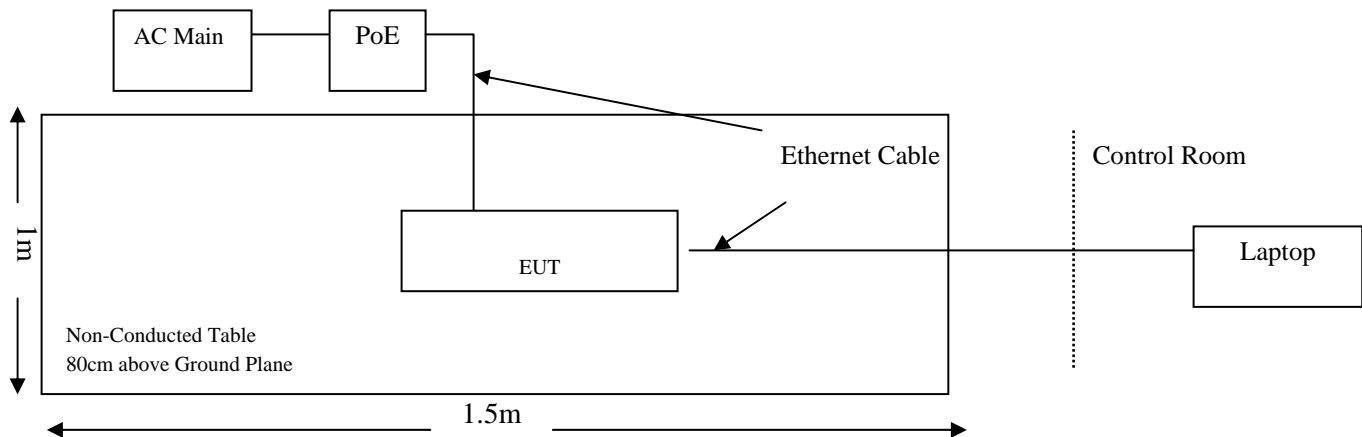

## 8.6 Test Equipment List and Details

Manufacturer	Description	Model	Serial Number	Calibration Date
Sunol Science Corp	Combination Antenna	JB1	A020106-1	2010-05-28
Rohde & Schwarz	EMI Test Receiver	ESCI 1166.5950K03	100337	2011-03-21
Sunol Science Corp	System Controller	SC99V	122303-1	N/R
A.R.A Inc	Horn antenna	DRG-1181A	1132	2010-11-29
Agilent	PSA Series Spectrum Analyzer	E4446A	US44300386	2010-08-18
Mini-Circuits	Pre Amplifier	ZVA-183-S	570400946	2011-05-09

**Statement of Traceability:** BACL attests that all calibrations have been performed per the NVLAP requirements, traceable to NIST.

## 8.7 Test Environmental Conditions

<b>Temperature:</b>	18~21 °C
<b>Relative Humidity:</b>	30~35 %
<b>ATM Pressure:</b>	101.2-102.2kPa

The testing was performed by Jerry Huang on 2011-05-02 ~ 2011-05-10 in 5 meter chamber 3.

## 8.8 Summary of Test Results

According to the data hereinafter, the EUT complied with the FCC Part 15, Subpart C, section 15.205, 15.209 and 15.247 & IC RSS-210, RSS-Gen standard's radiated emissions limits, and had the worst margin of:

2.4 GHz Band:

<b>Mode: Transmitting</b>			
<b>Margin (dB)</b>	<b>Frequency (MHz)</b>	<b>Polarization (Horizontal/Vertical)</b>	<b>Channel, Range</b>
-2.54	333.36	Vertical	30 MHz-1 GHz
-	-	-	Above 1GHz

5.8 GHz Band:

<b>Mode: Transmitting</b>			
<b>Margin (dB)</b>	<b>Frequency (MHz)</b>	<b>Polarization (Horizontal/Vertical)</b>	<b>Channel, Range</b>
-3.38	126.1318	Vertical	30 MHz-1 GHz
-0.362	2485	Vertical	Above 1GHz

Please refer to the following table and plots for specific test result details

### 8.9 Radiated Emissions Test Result Data

#### 1) Radiated Emission at 3 meters, 30 MHz – 1 GHz

2.4 GHz Band, 5 MHz Bandwidth, EIRP +36 dBm

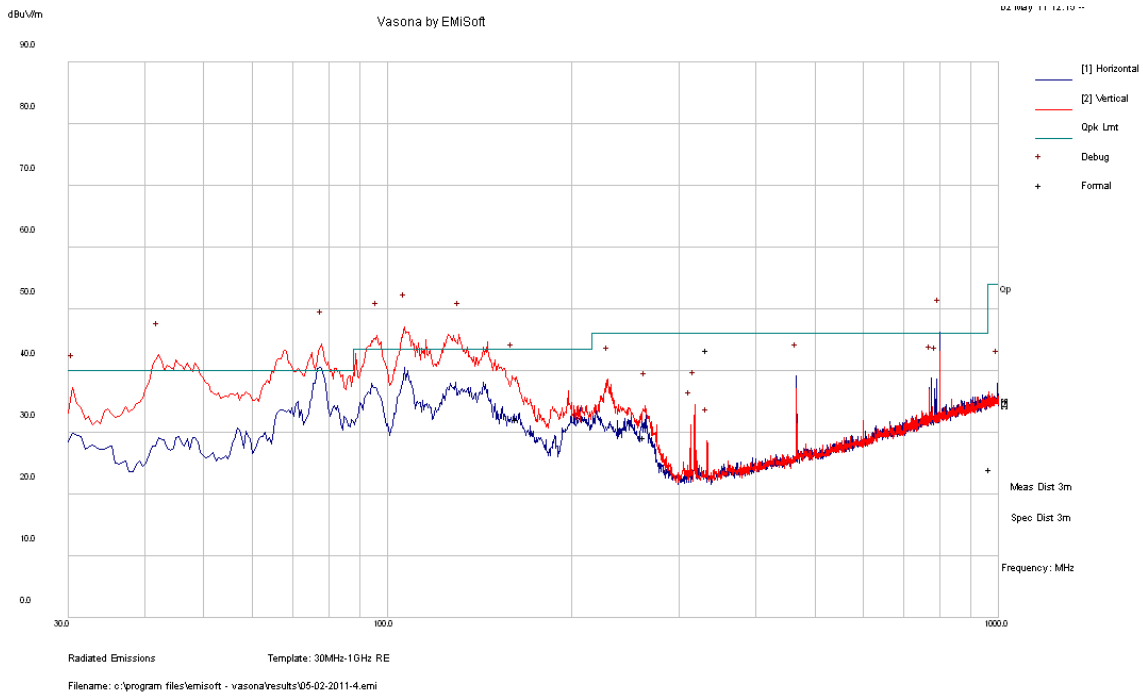

#### Quasi-Peak Measurements

Frequency (MHz)	Corrected Amplitude (dBμV/m)	Antenna Height (cm)	Antenna Polarity (H/V)	Turntable Azimuth (degrees)	Limit (dBμV/m)	Margin (dB)
131.119	39.26	114	V	342	43.5	-4.24
263.8515	29.07	204	V	38	46	-16.93
333.3153	28.25	132	V	203	46	-17.75
995.942	24.3	217	H	175	54	-29.70

2.4 GHz Band, 20 MHz Bandwidth, EIRP +36 dBm

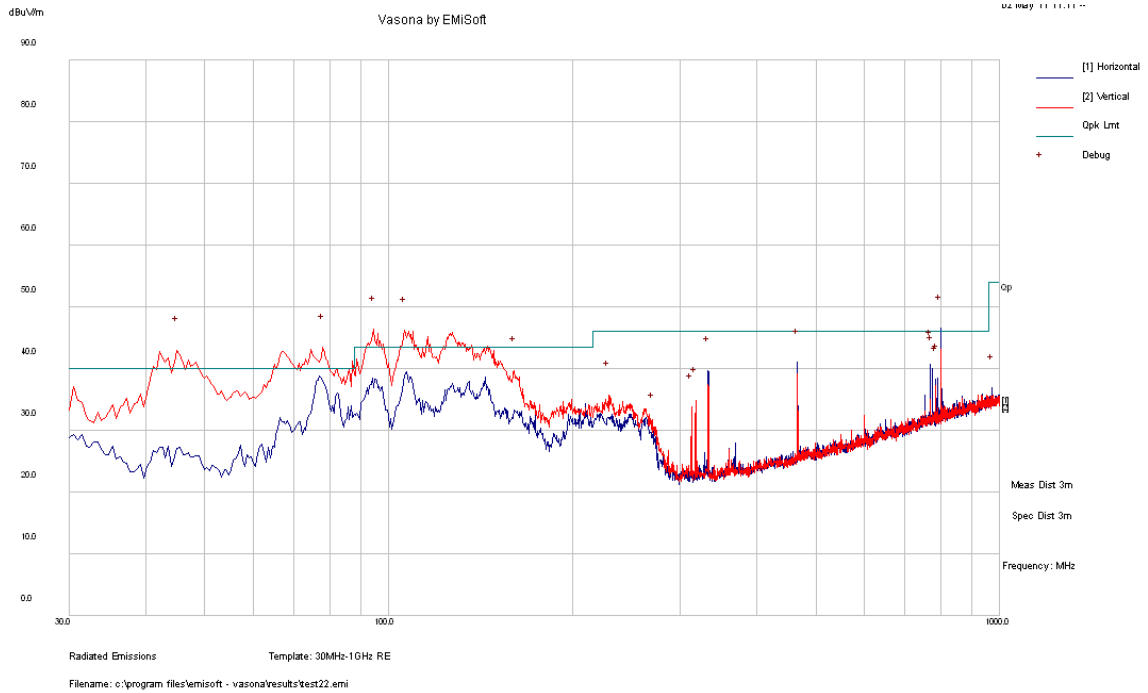

Quasi-Peak Measurements

Frequency (MHz)	Corrected Amplitude (dBµV/m)	Antenna Height (cm)	Antenna Polarity (H/V)	Turntable Azimuth (degrees)	Limit (dBµV/m)	Margin (dB)
333.36	43.46	118	V	191	46	-2.54
125.6843	40.59	141	V	82	43.5	-2.91
162.445	32.09	141	V	143	43.5	-11.41
263.0565	29.2	220	V	37	46	-16.80
966.4188	24.01	110	V	331	54	-29.99

5.8 GHz Band, 5 MHz Bandwidth, EIRP +36 dBm

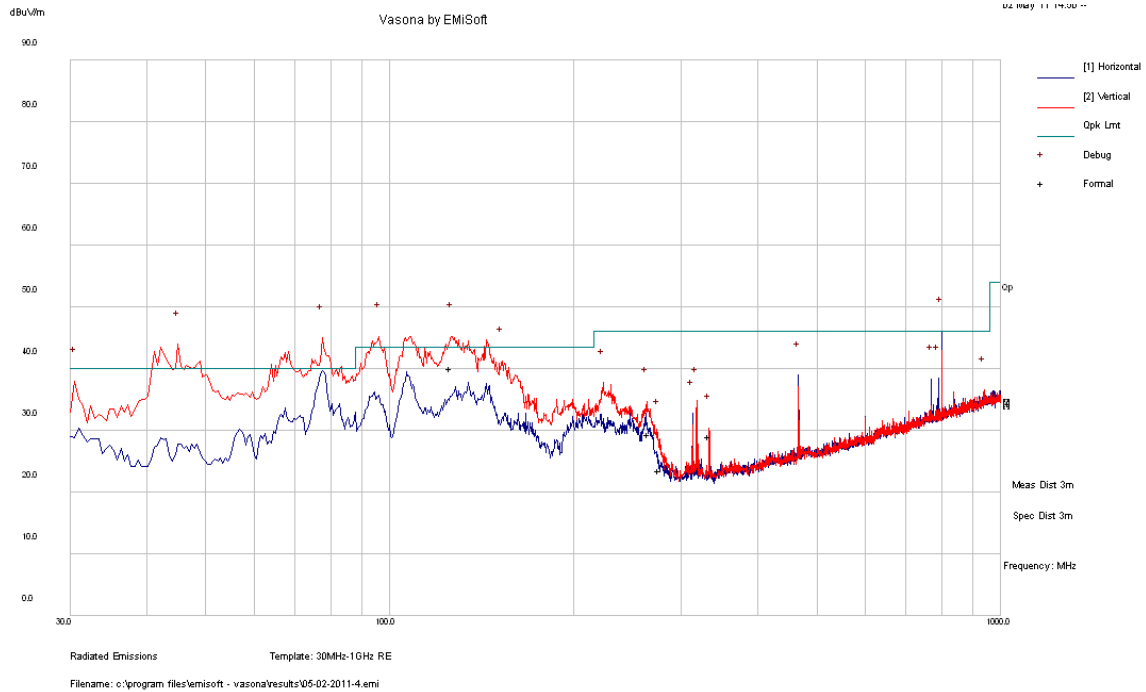

Quasi-Peak Measurements

Frequency (MHz)	Corrected Amplitude (dBµV/m)	Antenna Height (cm)	Antenna Polarity (H/V)	Turntable Azimuth (degrees)	Limit (dBµV/m)	Margin (dB)
126.1318	40.12	141	V	24	43.5	-3.38
333.306	29.53	118	V	192	46	-16.47
263.232	27.47	155	V	260	46	-18.53
274.7	20	110	V	253	46	-26

5.8 GHz Band, 20 MHz Bandwidth, EIRP +36 dBm

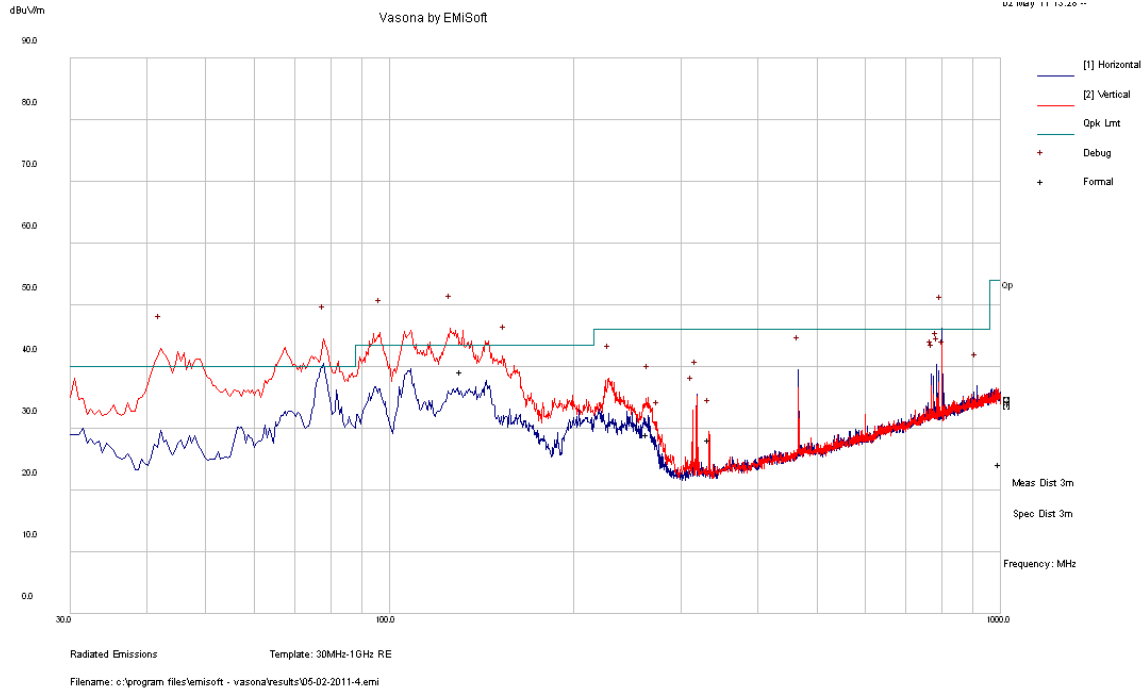

Quasi-Peak Measurements

Frequency (MHz)	Corrected Amplitude (dBµV/m)	Antenna Height (cm)	Antenna Polarity (H/V)	Turntable Azimuth (degrees)	Limit (dBµV/m)	Margin (dB)
125.7228	40.07	107	V	339	43.5	-3.43
264.8148	29.48	100	V	321	46	-16.52
333.3213	29.13	116	V	195	46	-16.87
275.581	23.54	135	V	264	46	-22.46



**2) Radiated Emission at 3 meters, above 1GHz**

2.4 GHz Band, EIRP +36 dBm

5 MHz Bandwidth:

Frequency (MHz)	S.A. Reading (dB $\mu$ V)	Turntable Azimuth (degrees)	Test Antenna			Cable Loss (dB)	Pre-Amp. (dB)	Cord. Reading (dB $\mu$ V/m)	FCC/IC		Comments
			Height (m)	Polarity (H/V)	Factor (dB/m)				Limit (dB $\mu$ V/m)	Margin (dB)	
Low Channel 2412 MHz, measured at 3 meters											
-	-	-	-	-	-	-	-	-	-	-	- <sup>1</sup>
Middle Channel 2437 MHz measured at 3 meters											
-	-	-	-	-	-	-	-	-	-	-	- <sup>1</sup>
High Channel 2462 MHz measured at 3 meters											
-	-	-	-	-	-	-	-	-	-	-	- <sup>1</sup>

20 MHz Bandwidth:

Frequency (MHz)	S.A. Reading (dB $\mu$ V)	Turntable Azimuth (degrees)	Test Antenna			Cable Loss (dB)	Pre-Amp. (dB)	Cord. Reading (dB $\mu$ V/m)	FCC/IC		Comments
			Height (m)	Polarity (H/V)	Factor (dB/m)				Limit (dB $\mu$ V/m)	Margin (dB)	
Low Channel 2412 MHz, measured at 3 meters											
-	-	-	-	-	-	-	-	-	-	-	- <sup>1</sup>
Middle Channel 2437 MHz measured at 3 meters											
-	-	-	-	-	-	-	-	-	-	-	- <sup>1</sup>
High Channel 2462 MHz measured at 3 meters											
-	-	-	-	-	-	-	-	-	-	-	- <sup>1</sup>

5.8 GHz Band, EIRP +36 dBm

5 MHz Bandwidth:

Frequency (MHz)	S.A. Reading (dB $\mu$ V)	Turntable Azimuth (degrees)	Test Antenna			Cable Loss (dB)	Pre-Amp. (dB)	Cord. Reading (dB $\mu$ V/m)	FCC/IC		Comments
			Height (m)	Polarity (H/V)	Factor (dB/m)				Limit (dB $\mu$ V/m)	Margin (dB)	
Low Channel 5745 MHz, measured at 3 meters											
-	-	-	-	-	-	-	-	-	-	-	- <sup>1</sup>
Middle Channel 5785 MHz measured at 3 meters											
2485	62.44	198	185	V	27.778	3.25	27.9	65.568	74	-8.432	peak
2485	53.7	119	196	H	27.778	3.25	27.9	56.828	74	-17.172	peak
2485	50.51	198	185	V	27.778	3.25	27.9	53.638	54	-0.362	Ave
2485	41.08	119	196	H	27.778	3.25	27.9	44.208	54	-9.792	Ave
High Channel 5825 MHz measured at 3 meters											
-	-	-	-	-	-	-	-	-	-	-	- <sup>1</sup>

<sup>1</sup> Note: All the Restricted Band Frequencies are more than 20 dB below the margin

20 MHz Bandwidth:

Frequency (MHz)	S.A. Reading (dBµV)	Turntable Azimuth (degrees)	Test Antenna			Cable Loss (dB)	Pre-Amp. (dB)	Cord. Reading (dBµV/m)	FCC/IC		Comments
			Height (m)	Polarity (H/V)	Factor (dB/m)				Limit (dBµV/m)	Margin (dB)	
Low Channel 5745 MHz, measured at 3 meters											
-	-	-	-	-	-	-	-	-	-	-	- <sup>1</sup>
Middle Channel 5785 MHz measured at 3 meters											
2485	58.96	193	184	V	27.778	3.25	27.9	62.088	74	-11.912	peak
2485	50.7	120	198	H	27.778	3.25	27.9	53.828	74	-20.172	peak
2485	48.74	193	184	V	27.778	3.25	27.9	51.868	54	-2.132	Ave
2485	40.59	120	198	H	27.778	3.25	27.9	43.718	54	-10.282	Ave
High Channel 5825 MHz measured at 3 meters											
-	-	-	-	-	-	-	-	-	-	-	- <sup>1</sup>

<sup>1</sup> Note: All the Restricted Band Frequencies are more than 20 dB below the margin

### 3) Restricted Band Emissions

#### 2.4 GHz Band

5 MHz Bandwidth

2412 MHz, Lowest Channel at Horizontal, Peak

2412 MHz, Lowest Channel at Horizontal, Average

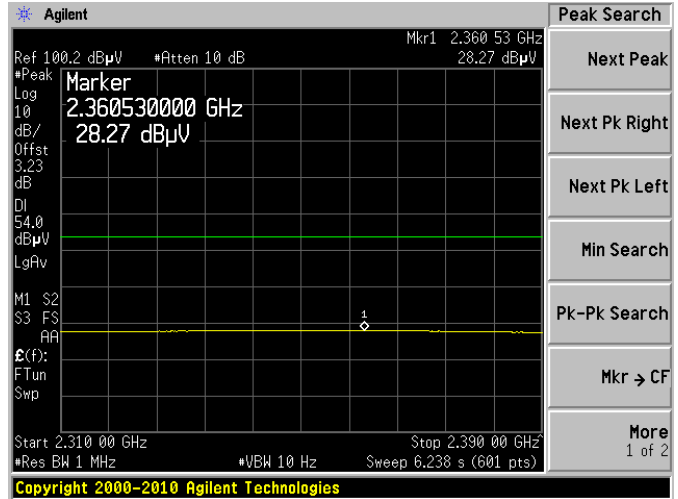
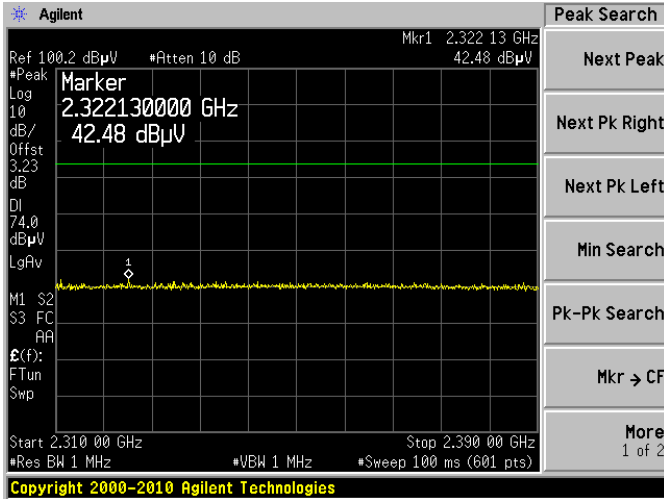

2412 MHz, Lowest Channel at Vertical, Peak

2412 MHz, Lowest Channel at Vertical, Average

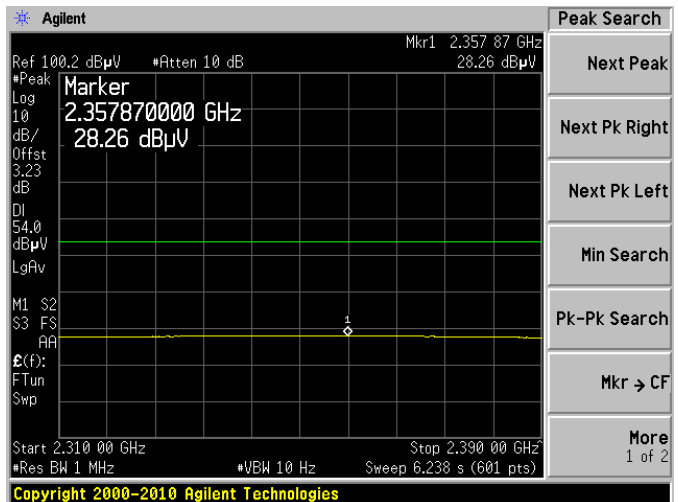
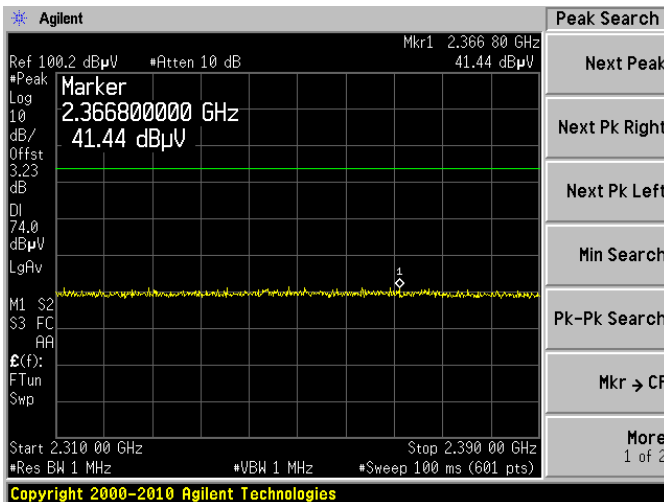

2462 MHz, Highest Channel at Horizontal, Peak

2462 MHz, Highest Channel at Horizontal, Average

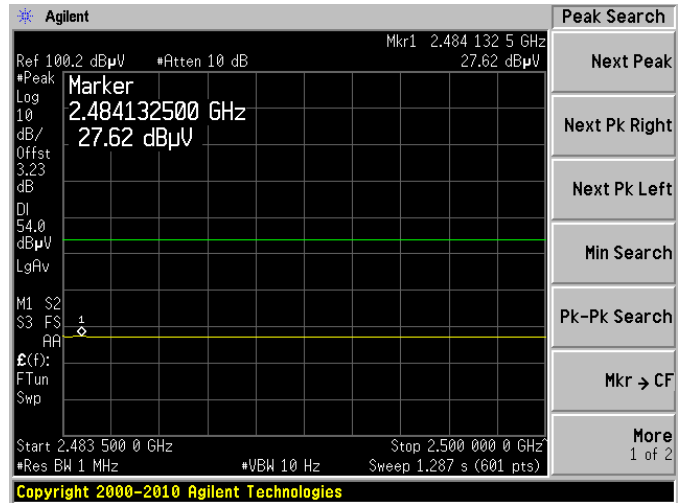
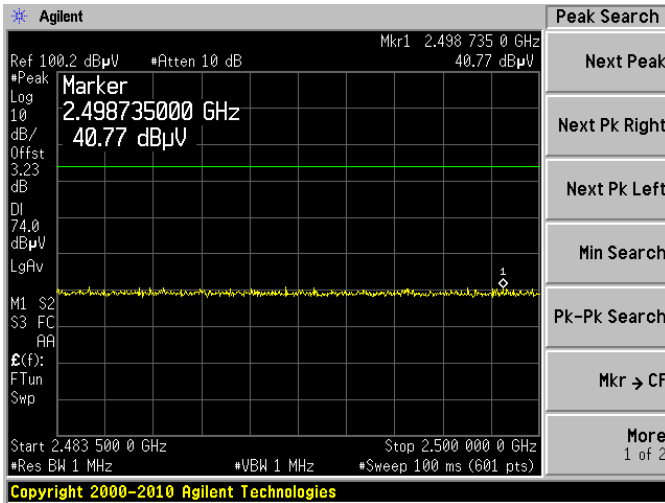

2462 MHz, Highest Channel at Vertical, Peak

2462 MHz, Highest Channel at Vertical, Average

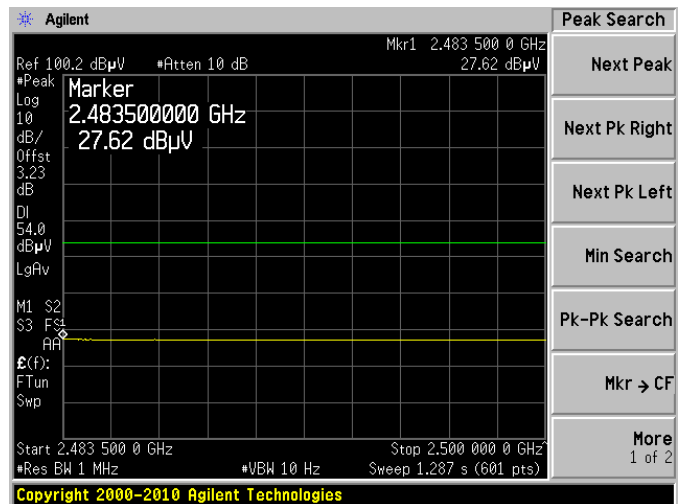
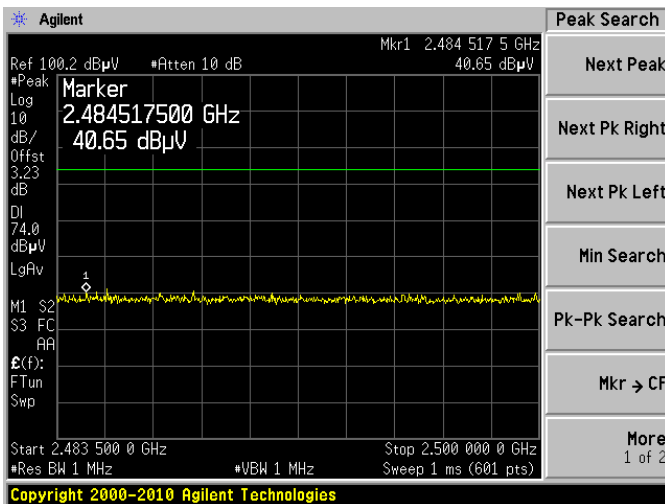

20 MHz Bandwidth

2412 MHz, Lowest Channel at Horizontal, Peak

2412 MHz, Lowest Channel at Horizontal, Average

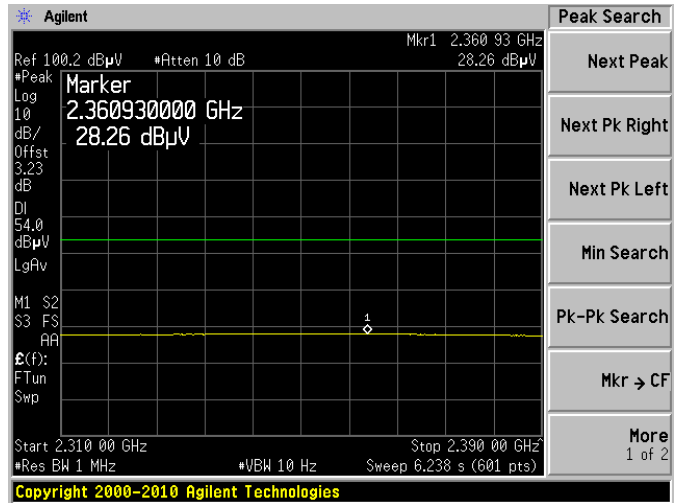
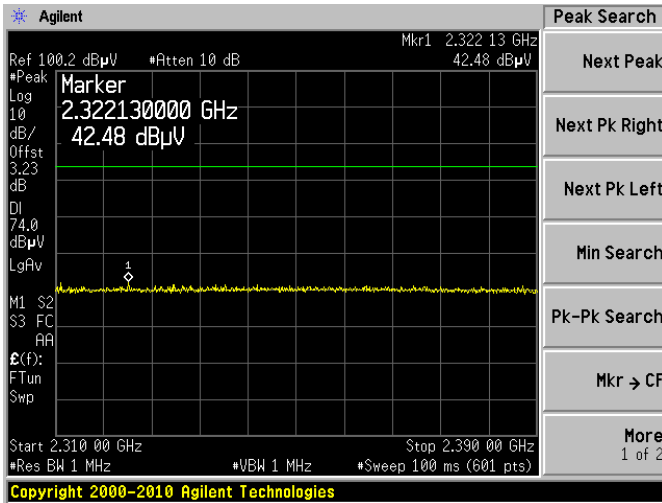

2412 MHz, Lowest Channel at Vertical, Peak

2412 MHz, Lowest Channel at Vertical, Average

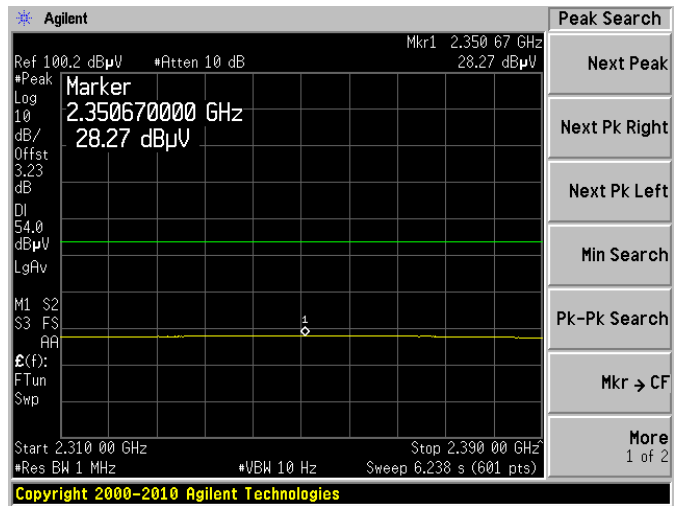
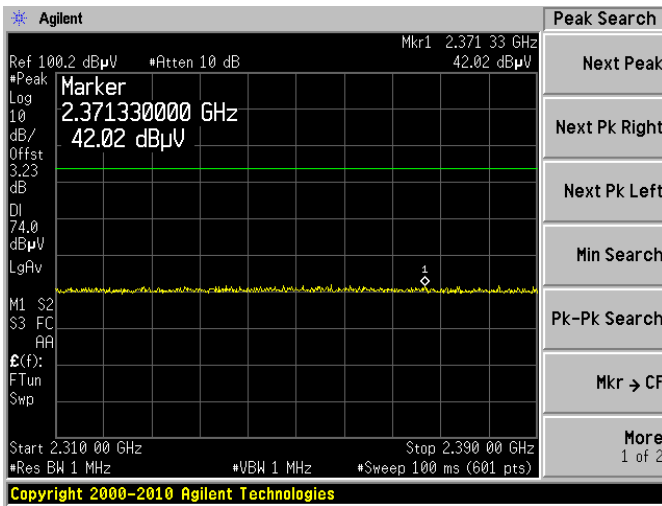

2462 MHz, Highest Channel at Horizontal, Peak

2462 MHz, Highest Channel at Horizontal, Average

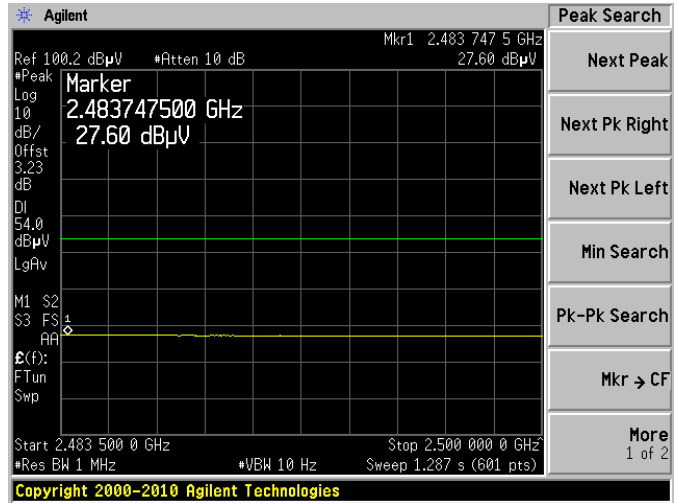
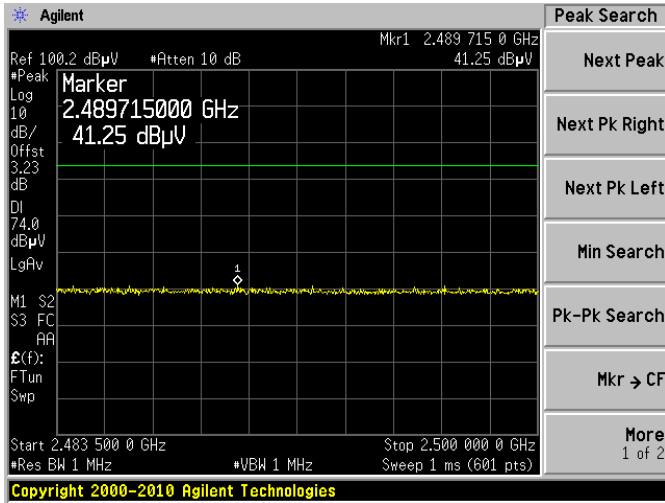

2462 MHz, Highest Channel at Vertical, Peak

2462 MHz, Highest Channel at Vertical, Average

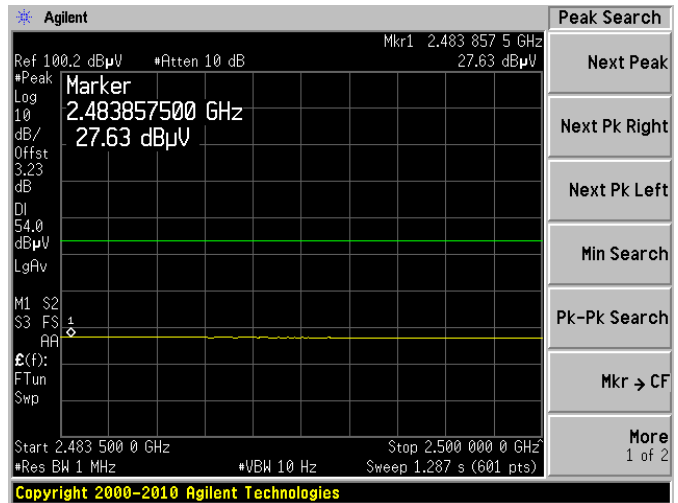
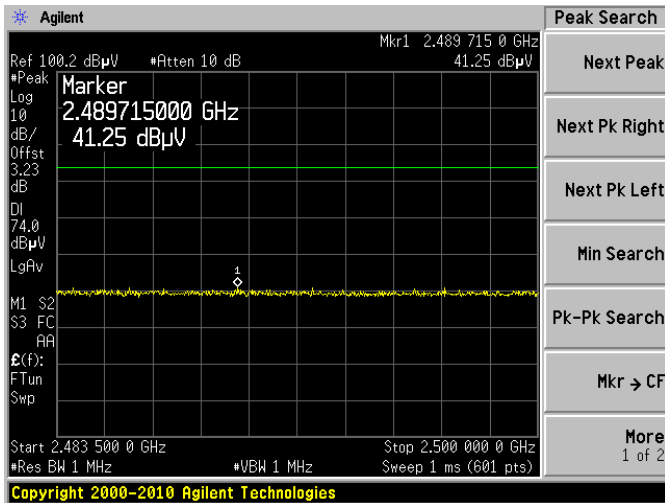

### 5.8 GHz Band

#### 5 MHz Bandwidth

5745 MHz, Lowest Channel at Horizontal, Peak

5745 MHz, Lowest Channel at Horizontal, Average

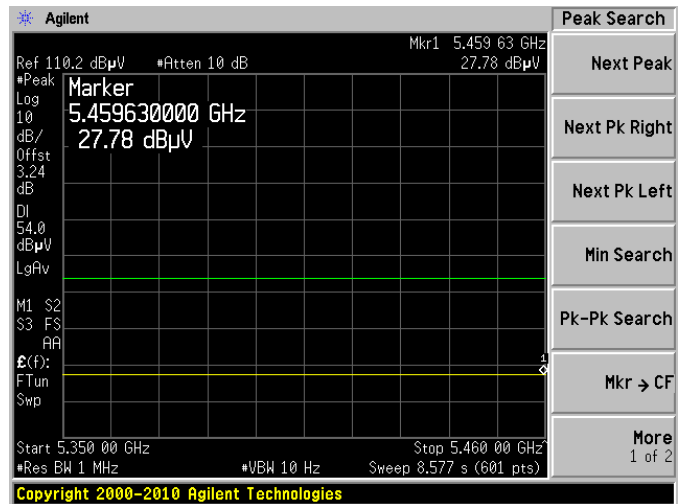
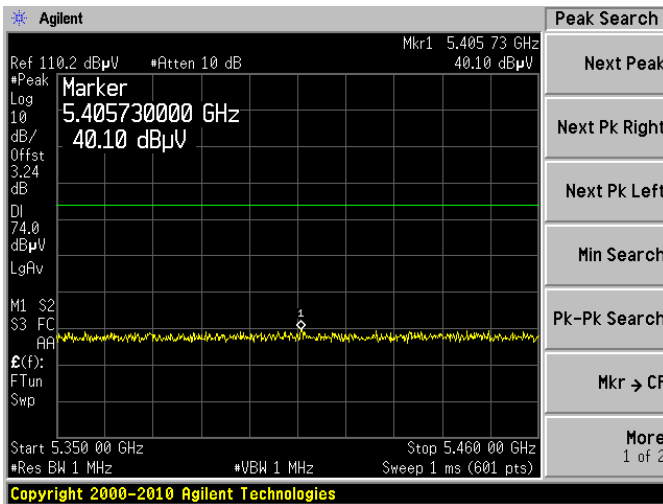

5745 MHz, Lowest Channel at Vertical, Peak

5745 MHz, Lowest Channel at Vertical, Average

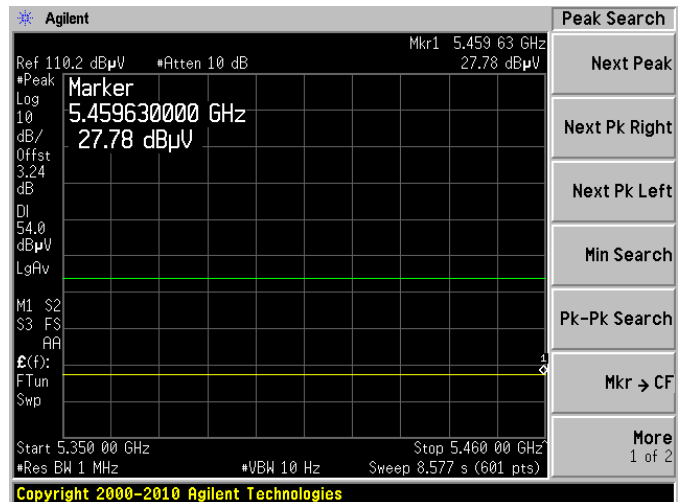
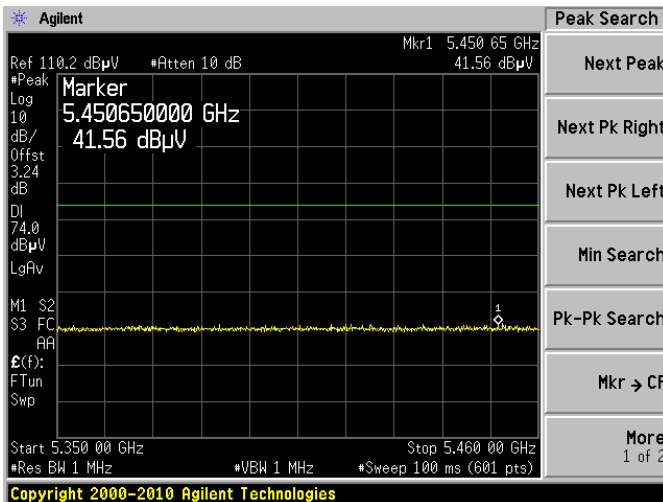

5825 MHz, Highest Channel at Horizontal, Peak

5825 MHz, Highest Channel at Horizontal, Average

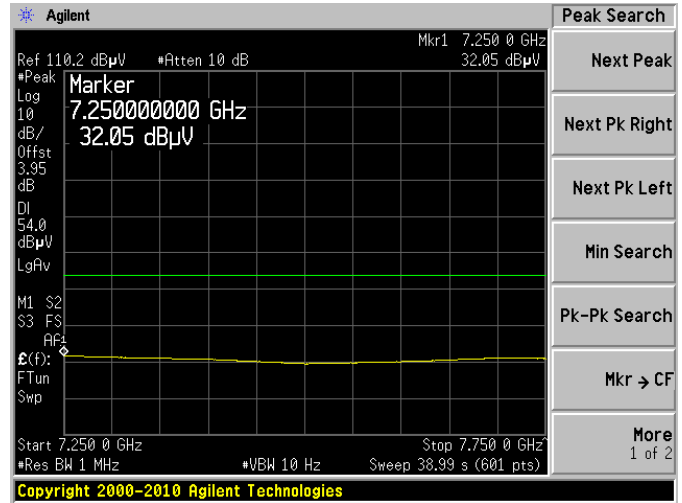
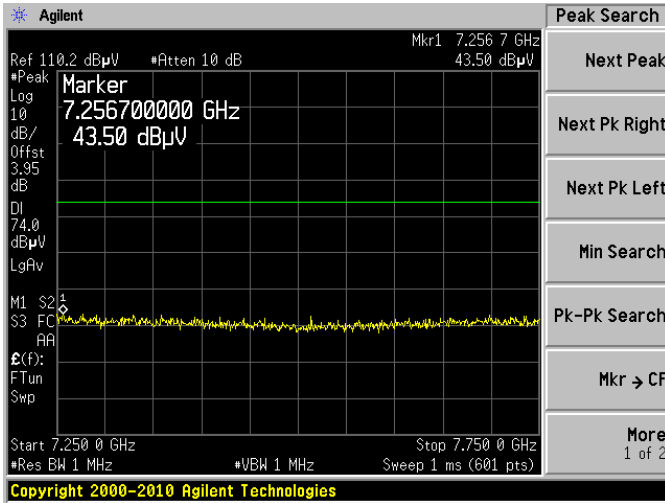

5825 MHz, Highest Channel at Vertical, Peak

5825 MHz, Highest Channel at Vertical, Average

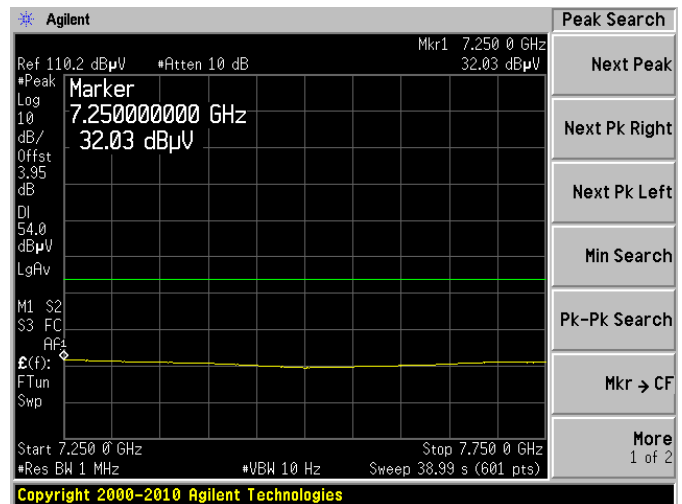
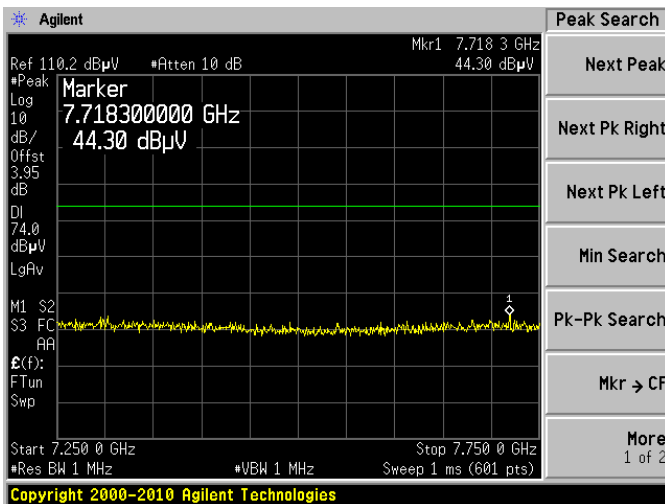



20 MHz Bandwidth

5745 MHz, Lowest Channel at Horizontal, Peak

5745 MHz, Lowest Channel at Horizontal, Average

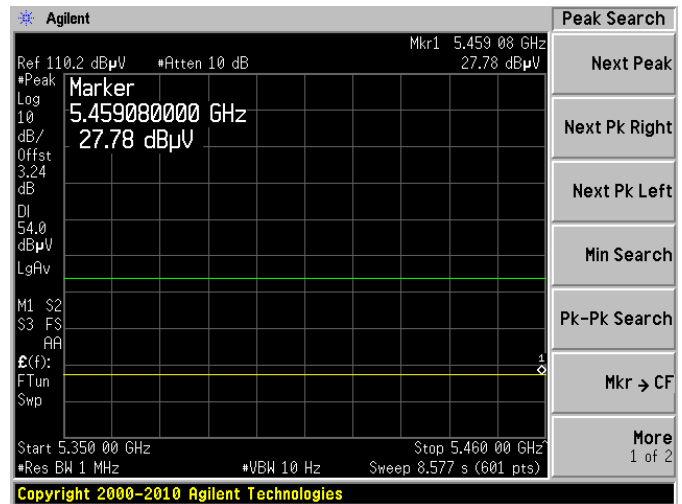
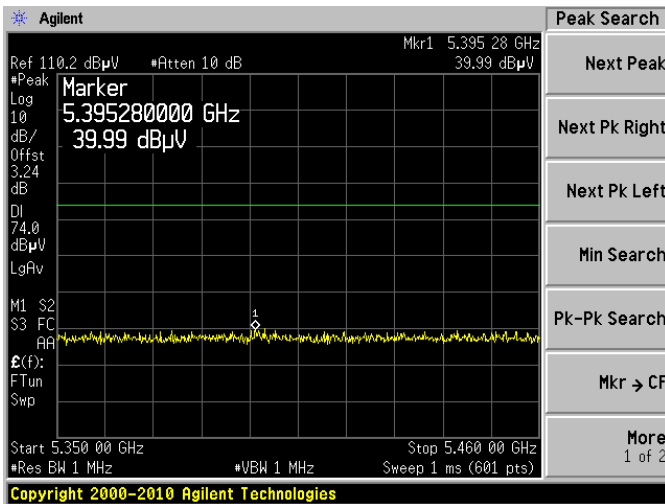

5745 MHz, Lowest Channel at Vertical, Peak

5745 MHz, Lowest Channel at Vertical, Average

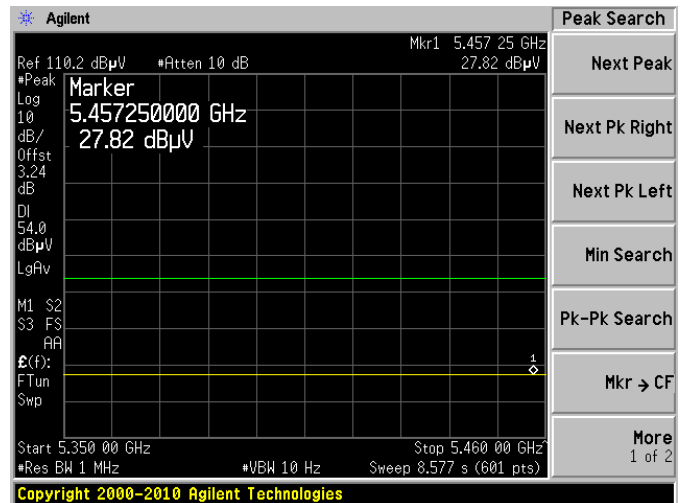
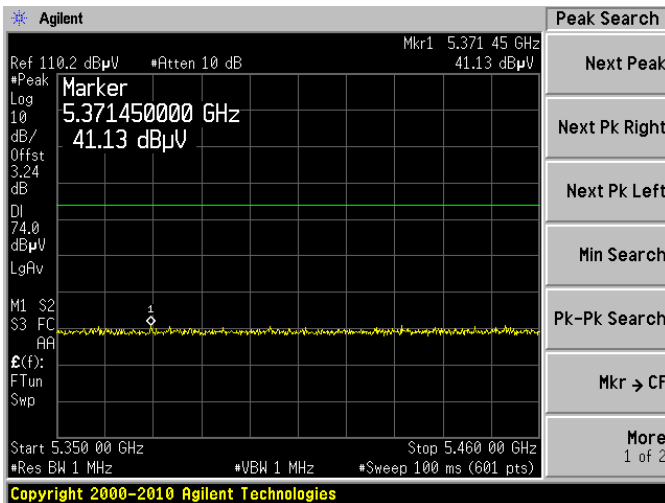

5825 MHz, Middle Channel at Horizontal, Peak

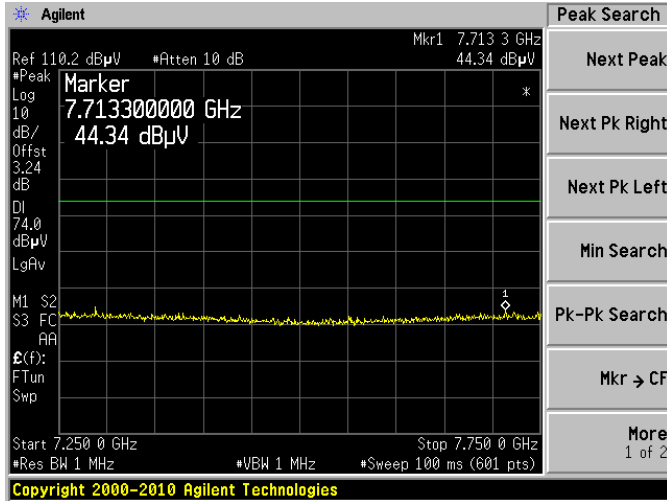

5825 MHz, Middle Channel at Horizontal, Average

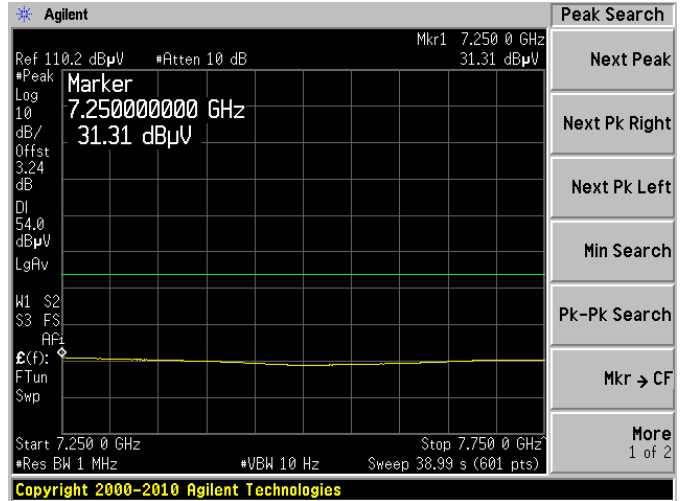

5825 MHz, Middle Channel at Vertical, Peak

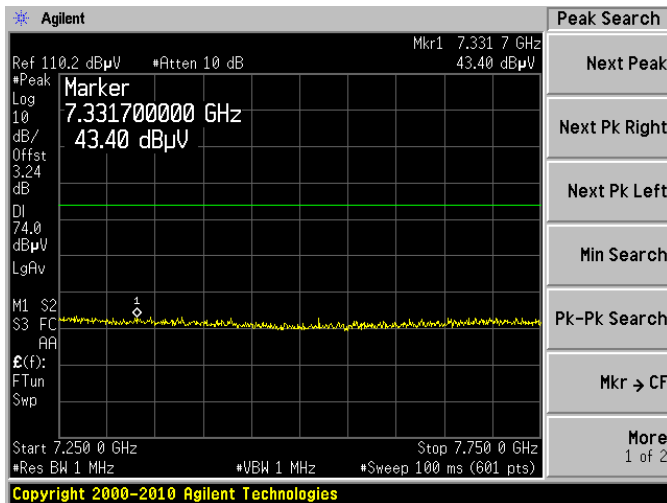

5825 MHz, Middle Channel at Vertical, Average

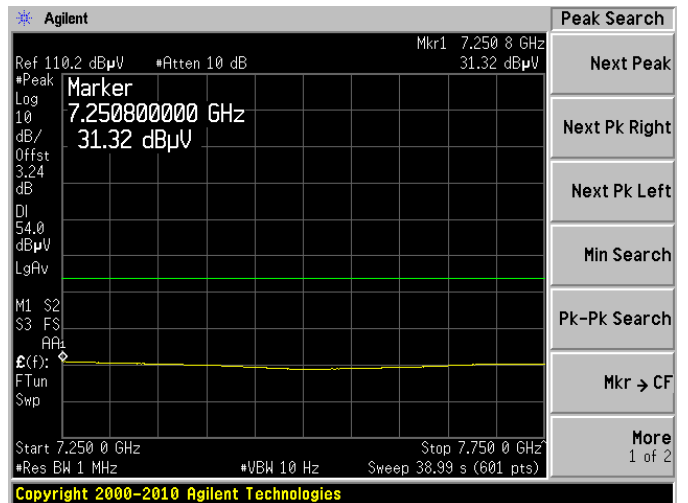

## 9 FCC §15.247(a)(2) & IC RSS-210 §A8.2 – 6 dB & 99% Emission Bandwidth

### 9.1 Applicable Standard

According to FCC §15.247(a)(2) and IC RSS-210 A8.2 (a), systems using digital modulation techniques may operate in the 902 - 928 MHz, 2400 - 2483.5 MHz, and 5725 - 5850 MHz bands. The minimum 6 dB bandwidth shall be at least 500 kHz

### 9.2 Measurement Procedure

1. Check the calibration of the measuring instrument using either an internal calibrator or a known signal from an external generator.
2. Position the EUT without connection to measurement instrument. Turn on the EUT and connect it to measurement instrument. Then set it to any one convenient frequency within its operating range. Set a reference level on the measuring instrument equal to the highest peak value.
3. Measure the frequency difference of two frequencies that were attenuated 6 dB from the reference level. Record the frequency difference as the emissions bandwidth.
4. Repeat above procedures until all frequencies measured were complete.

### 9.3 Test Setup Block Diagram

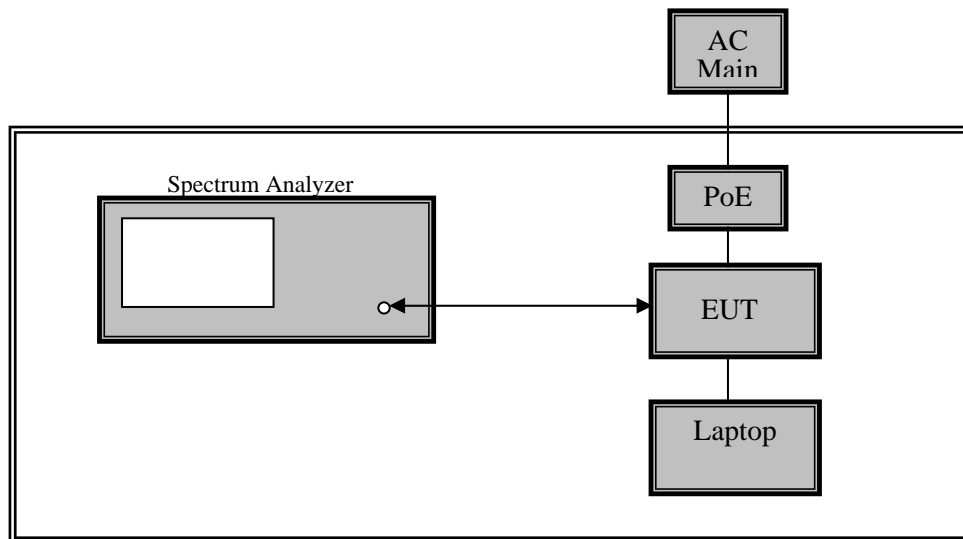

## 9.4 Test Equipment List and Details

Manufacturers	Description	Models	Serial Numbers	Calibration Dates
Agilent	Spectrum Analyzer	E4445A	MY44020562	2011-04-05

**Statement of Traceability:** BACL Corp. attests that all calibrations have been performed per the NVLAP requirements, traceable to the NIST.

## 9.5 Test Environmental Conditions

<b>Temperature:</b>	16.5~27°C
<b>Relative Humidity:</b>	30.9~43.3 %
<b>ATM Pressure:</b>	101-103 kPa

The testing was performed by Brian Fox on 2011-05-13 ~ 2011-05-20.

## 9.6 Test Results

### 2.4 GHz Band (2412–2462 MHz) - BPSK at 5 MHz Bandwidth

(Test results are represented in worse-case):

Antenna #1:

Radio Mode	Channel	Frequency (MHz)	6 dB Emission Bandwidth (MHz)	99% Emission Bandwidth (MHz)	Limit (MHz)	Results
BPSK, EIRP +20 dBm	Low	2412	4.3955	4.201	> 0.5	Compliance
	Middle	2437	4.3949	4.166	> 0.5	Compliance
	High	2462	4.4122	4.174	> 0.5	Compliance

Antenna #2:

Radio Mode	Channel	Frequency (MHz)	6 dB Emission Bandwidth (MHz)	99% Emission Bandwidth (MHz)	Limit (MHz)	Results
BPSK, EIRP +20 dBm	Low	2412	4.4056	4.170	> 0.5	Compliance
	Middle	2437	4.4108	4.223	> 0.5	Compliance
	High	2462	4.4044	4.130	> 0.5	Compliance

## Antenna #3:

Radio Mode	Channel	Frequency (MHz)	6 dB Emission Bandwidth (MHz)	99% Emission Bandwidth (MHz)	Limit (MHz)	Results
BPSK, EIRP +20 dBm	Low	2412	4.4013	4.285	> 0.5	Compliance
	Middle	2437	4.4043	4.333	> 0.5	Compliance
	High	2462	4.4044	4.130	> 0.5	Compliance

## Antenna #4:

Radio Mode	Channel	Frequency (MHz)	6 dB Emission Bandwidth (MHz)	99% Emission Bandwidth (MHz)	Limit (MHz)	Results
BPSK, EIRP +20 dBm	Low	2412	4.3978	4.343	> 0.5	Compliance
	Middle	2437	4.4093	4.412	> 0.5	Compliance
	High	2462	4.4033	4.343	> 0.5	Compliance

**2.4 GHz Band (2412-2462 MHz) - BPSK at 20 MHz Bandwidth:**

(Test results are represented in worse-case):

## Antenna #1:

Radio Mode	Channel	Frequency (MHz)	6 dB Emission Bandwidth (MHz)	99% Emission Bandwidth (MHz)	Limit (MHz)	Results
BPSK, EIRP +20 dBm	Low	2412	17.5361	16.104	> 0.5	Compliance
	Middle	2437	17.4897	15.187	> 0.5	Compliance
	High	2462	17.4955	15.745	> 0.5	Compliance

## Antenna #2:

Radio Mode	Channel	Frequency (MHz)	6 dB Emission Bandwidth (MHz)	99% Emission Bandwidth (MHz)	Limit (MHz)	Results
BPSK, EIRP +20 dBm	Low	2412	17.5658	16.352	> 0.5	Compliance
	Middle	2437	17.5240	16.023	> 0.5	Compliance
	High	2462	17.5170	16.346	> 0.5	Compliance

## Antenna #3:

Radio Mode	Channel	Frequency (MHz)	6 dB Emission Bandwidth (MHz)	99% Emission Bandwidth (MHz)	Limit (MHz)	Results
BPSK, EIRP +20 dBm	Low	2412	17.5168	15.186	> 0.5	Compliance
	Middle	2437	17.4784	15.194	> 0.5	Compliance
	High	2462	17.4519	15.205	> 0.5	Compliance

## Antenna #4:

Radio Mode	Channel	Frequency (MHz)	6 dB Emission Bandwidth (MHz)	99% Emission Bandwidth (MHz)	Limit (MHz)	Results
BPSK, EIRP +20 dBm	Low	2412	17.5488	16.154	> 0.5	Compliance
	Middle	2437	17.5110	16.165	> 0.5	Compliance
	High	2462	17.5212	16.171	> 0.5	Compliance

**5.8 GHz Band (5745-5825MHz) - BPSK at 5 MHz Bandwidth:**

## Antenna #1:

Radio Mode	Channel	Frequency (MHz)	6 dB Emission Bandwidth (MHz)	99% Emission Bandwidth (MHz)	Limit (MHz)	Results
BPSK, EIRP +30 dBm	Low	5745	4.4031	4.304	> 0.5	Compliance
	Middle	5785	4.4086	4.322	> 0.5	Compliance
	High	5825	4.4031	4.398	> 0.5	Compliance

## Antenna #2:

Radio Mode	Channel	Frequency (MHz)	6 dB Emission Bandwidth (MHz)	99% Emission Bandwidth (MHz)	Limit (MHz)	Results
BPSK, EIRP +30 dBm	Low	5745	4.4070	4.320	> 0.5	Compliance
	Middle	5785	4.3949	4.166	> 0.5	Compliance
	High	5825	4.4092	4.265	> 0.5	Compliance

## Antenna #3:

Radio Mode	Channel	Frequency (MHz)	6 dB Emission Bandwidth (MHz)	99% Emission Bandwidth (MHz)	Limit (MHz)	Results
BPSK, EIRP +30 dBm	Low	5745	4.4058	4.359	> 0.5	Compliance
	Middle	5785	4.4196	4.337	> 0.5	Compliance
	High	5825	4.3961	4.305	> 0.5	Compliance

## Antenna #4:

Radio Mode	Channel	Frequency (MHz)	6 dB Emission Bandwidth (MHz)	99% Emission Bandwidth (MHz)	Limit (MHz)	Results
BPSK, EIRP +30 dBm	Low	5745	4.4276	4.337	> 0.5	Compliance
	Middle	5785	4.4514	4.329	> 0.5	Compliance
	High	5825	4.4684	4.350	> 0.5	Compliance

**5.8 GHz Band (5745-5825 MHz) - BPSK at 20 MHz Bandwidth:**

(Test results are represented in worse-case):

## Antenna #1:

Radio Mode	Channel	Frequency (MHz)	6 dB Emission Bandwidth (MHz)	99% Emission Bandwidth (MHz)	Limit (MHz)	Results
BPSK, EIRP +30 dBm	Low	5745	17.5352	15.189	> 0.5	Compliance
	Middle	5785	17.5369	15.191	> 0.5	Compliance
	High	5825	17.5252	15.5994	> 0.5	Compliance

## Antenna #2:

Radio Mode	Channel	Frequency (MHz)	6 dB Emission Bandwidth (MHz)	99% Emission Bandwidth (MHz)	Limit (MHz)	Results
BPSK, EIRP +30 dBm	Low	5745	17.5684	17.052	> 0.5	Compliance
	Middle	5785	17.5566	16.359	> 0.5	Compliance
	High	5825	17.5614	16.147	> 0.5	Compliance

## Antenna #3:

Radio Mode	Channel	Frequency (MHz)	6 dB Emission Bandwidth (MHz)	99% Emission Bandwidth (MHz)	Limit (MHz)	Results
BPSK, EIRP +30 dBm	Low	5745	17.5311	15.726	> 0.5	Compliance
	Middle	5785	17.5342	15.191	> 0.5	Compliance
	High	5825	17.5340	15.191	> 0.5	Compliance

## Antenna #4:

Radio Mode	Channel	Frequency (MHz)	6 dB Emission Bandwidth (MHz)	99% Emission Bandwidth (MHz)	Limit (MHz)	Results
BPSK, EIRP +30 dBm	Low	5745	17.5755	16.997	> 0.5	Compliance
	Middle	5785	17.6269	16.973	> 0.5	Compliance
	High	5825	17.6624	16.910	> 0.5	Compliance

*Please refer to the following plots for detailed test results*



**2.4 GHz Band (2412-2462 MHz): BPSK with 5 MHz bandwidth**

Antenna #1:

EIRP +20 dBm ~ Low Channel

EIRP +20 dBm ~ Middle Channel

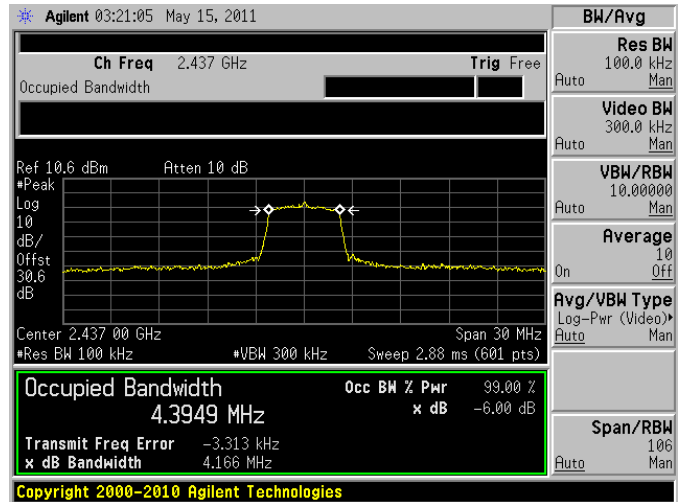
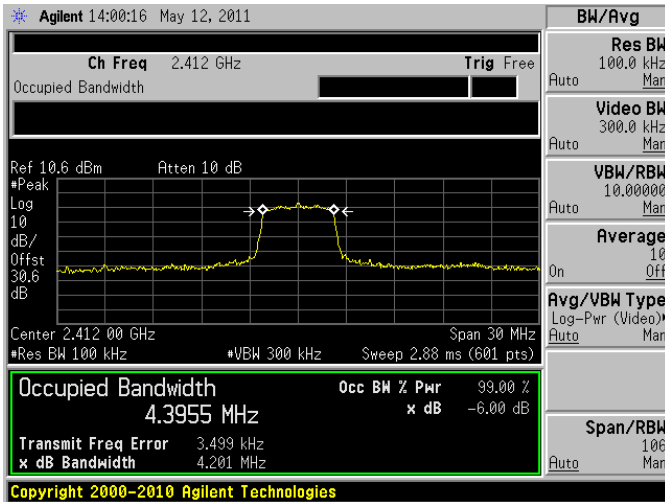

EIRP +20 dBm ~ High Channel

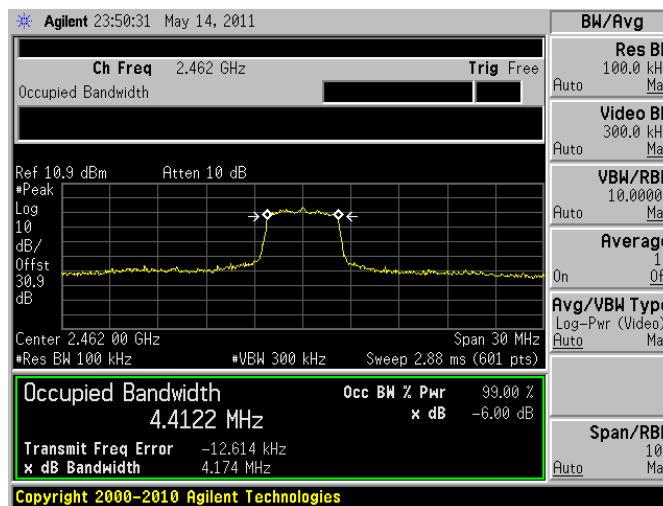

Antenna #2:

EIRP +20 dBm ~ Low Channel

EIRP +20 dBm ~ Middle Channel

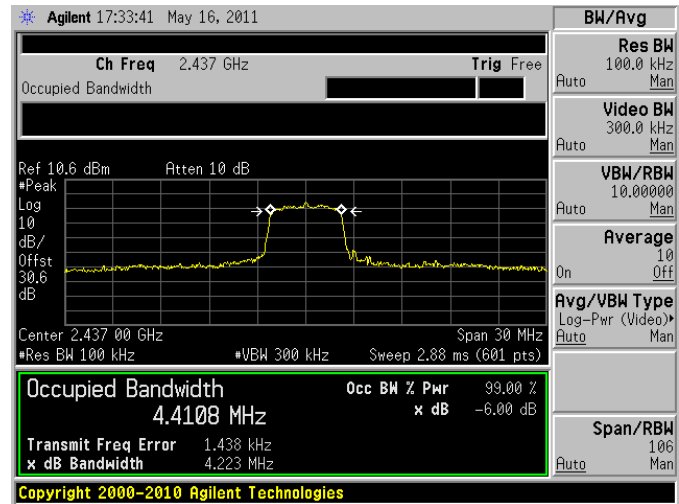
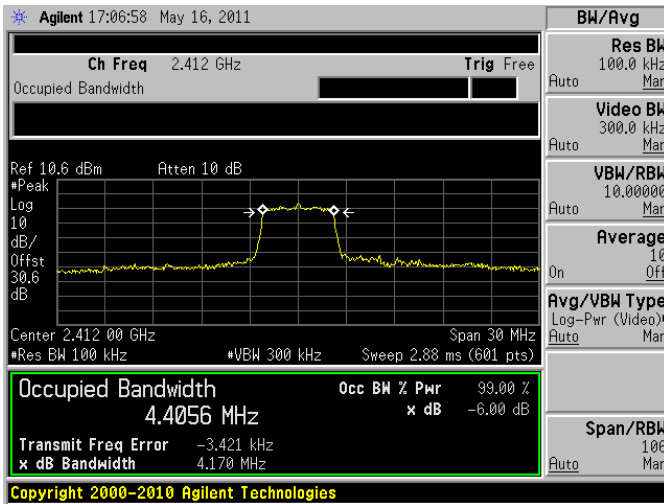

EIRP +20 dBm ~ High Channel

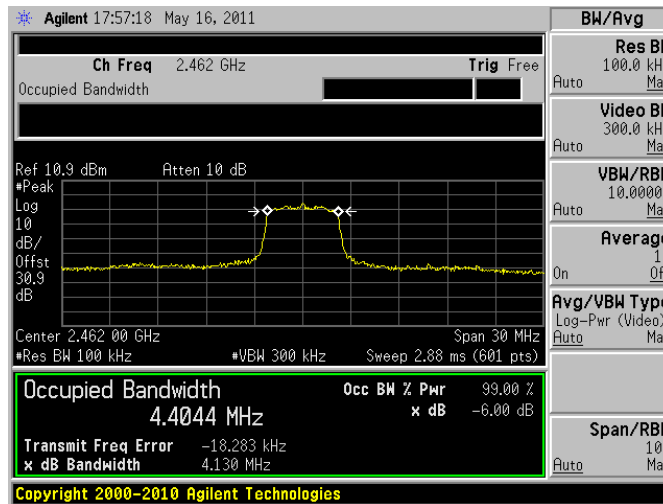

Antenna #3:

EIRP +20 dBm ~ Low Channel

EIRP +20 dBm ~ Middle Channel

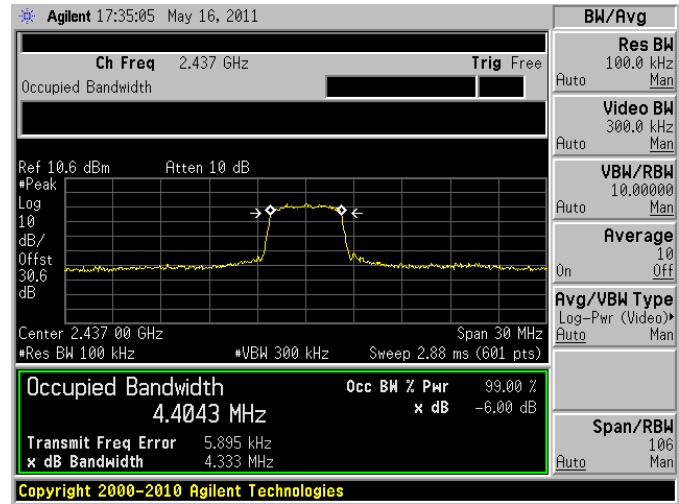
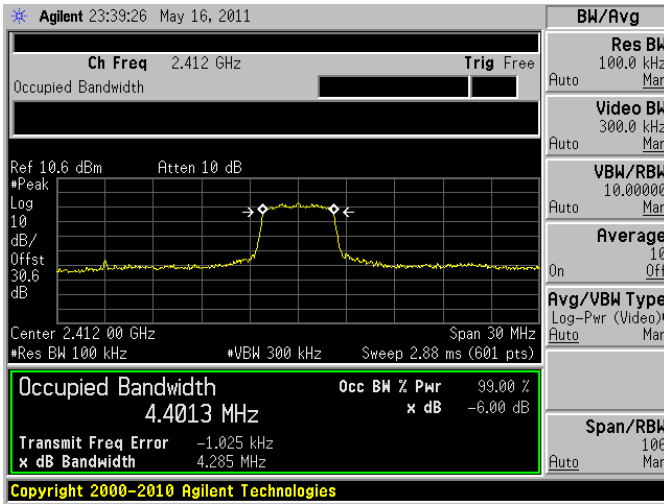

EIRP +20 dBm ~ High Channel

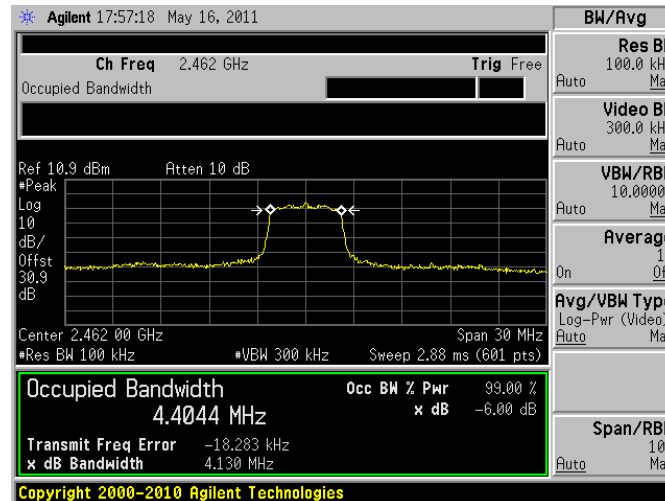

Antenna #4:

EIRP +20 dBm ~ Low Channel

EIRP +20 dBm ~ Middle Channel

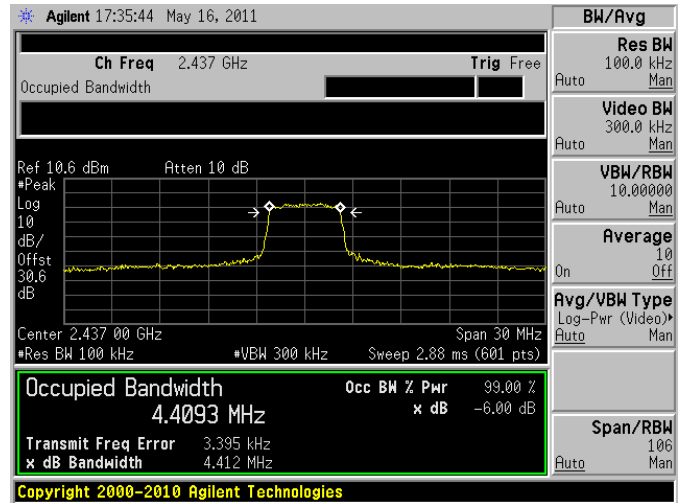
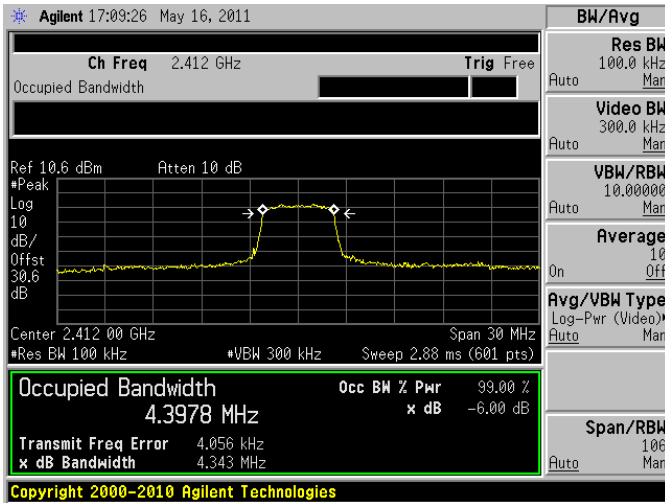

EIRP +20 dBm ~ High Channel

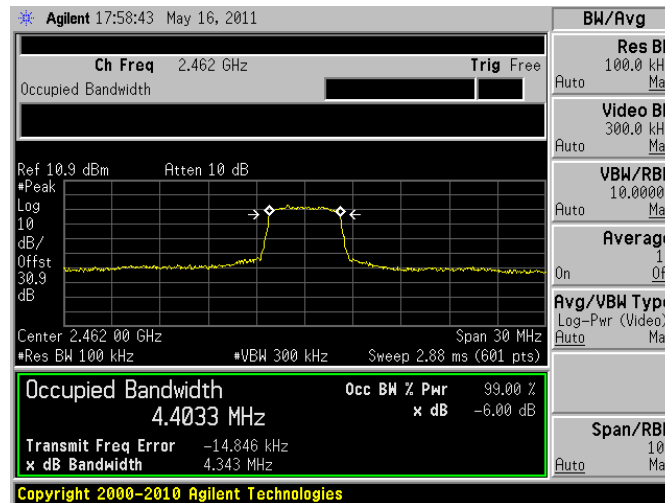

### 2.4 GHz Band (2412-2462 MHz): BPSK with 20 MHz bandwidth

Antenna #1:

EIRP +20 dBm ~ Low Channel

EIRP +20 dBm ~ Middle Channel

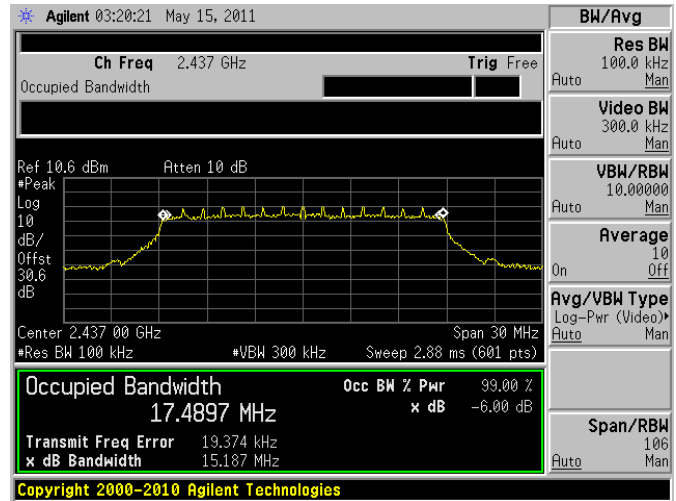
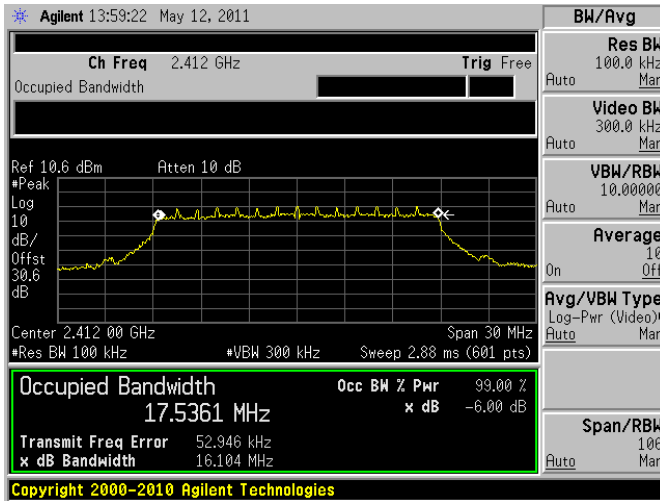

EIRP +20 dBm ~ High Channel

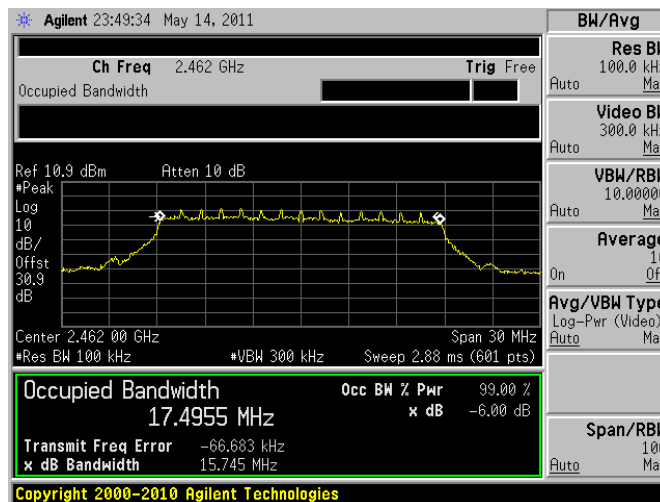

Antenna #2:

EIRP +20 dBm ~ Low Channel

EIRP +20 dBm ~ Middle Channel

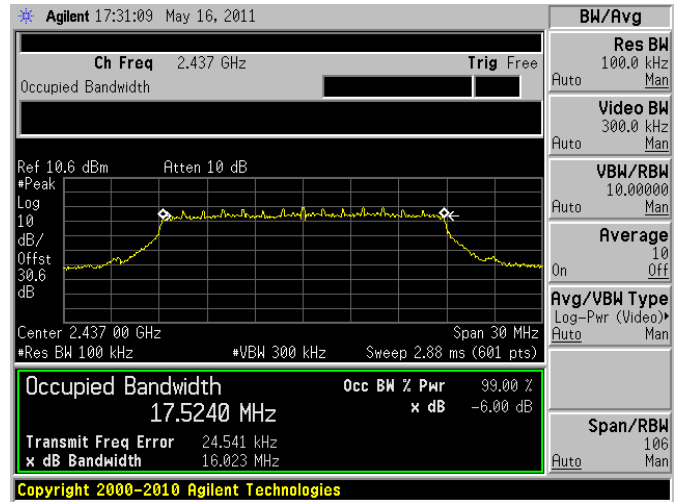
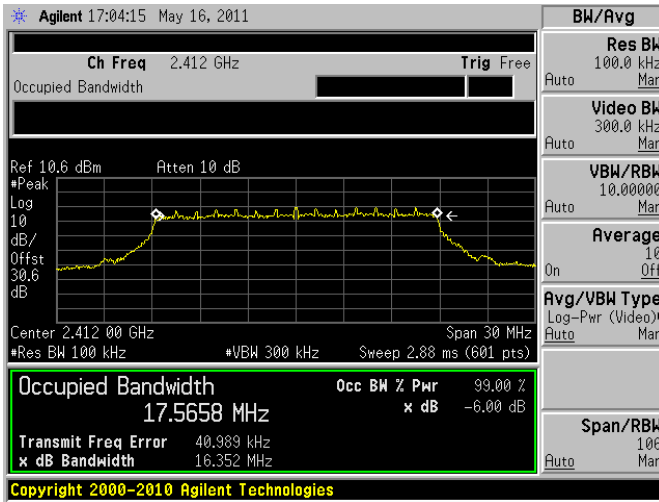

EIRP +20 dBm ~ High Channel

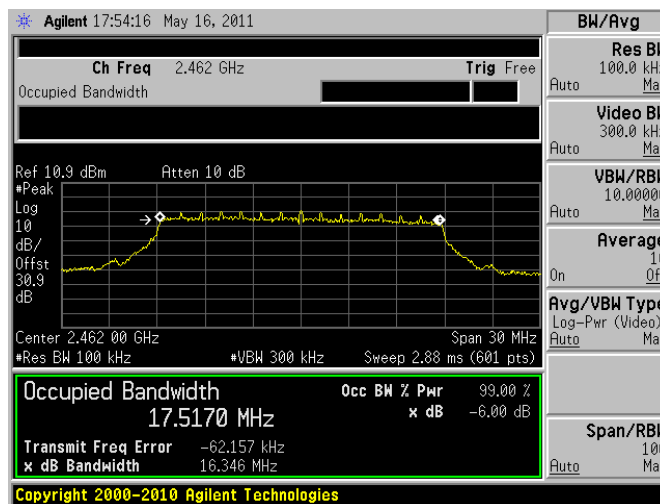

Antenna #3:

EIRP +20 dBm ~ Low Channel

EIRP +20 dBm ~ Middle Channel

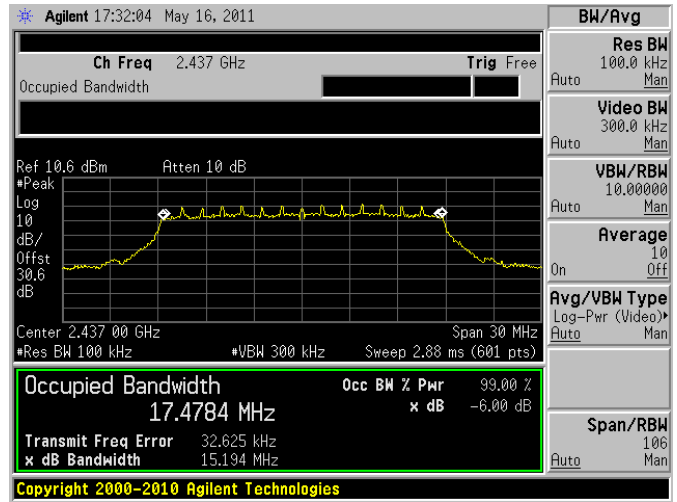
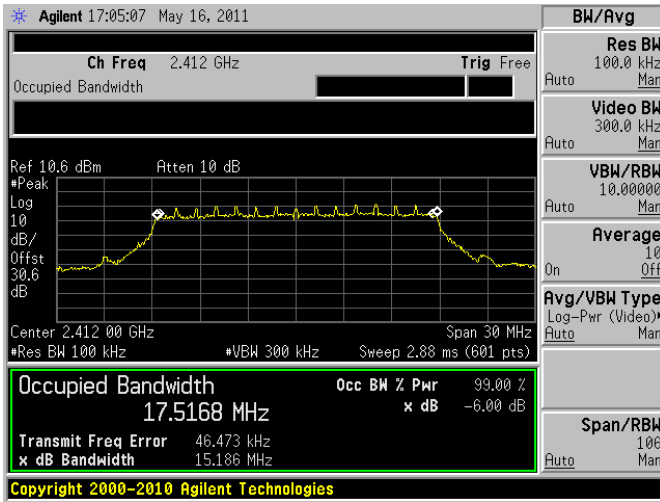

EIRP +20 dBm ~ High Channel

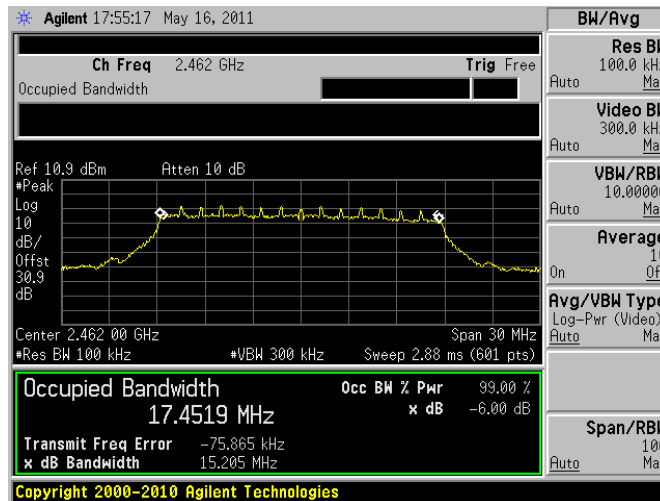

Antenna #4:

EIRP +20 dBm ~ Low Channel

EIRP +20 dBm ~ Middle Channel

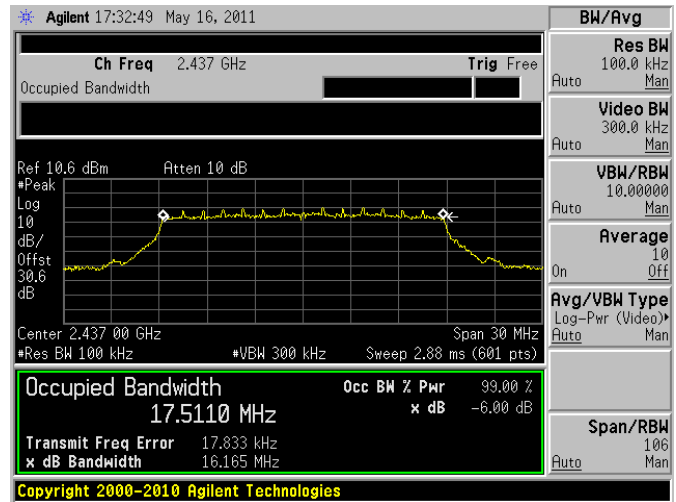
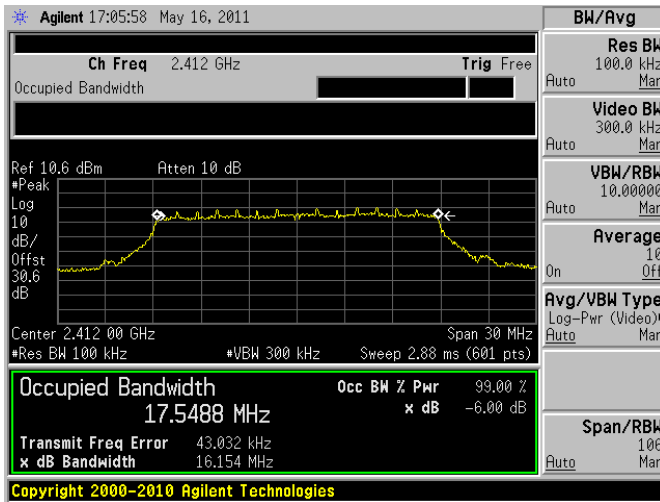

EIRP +20 dBm ~ High Channel

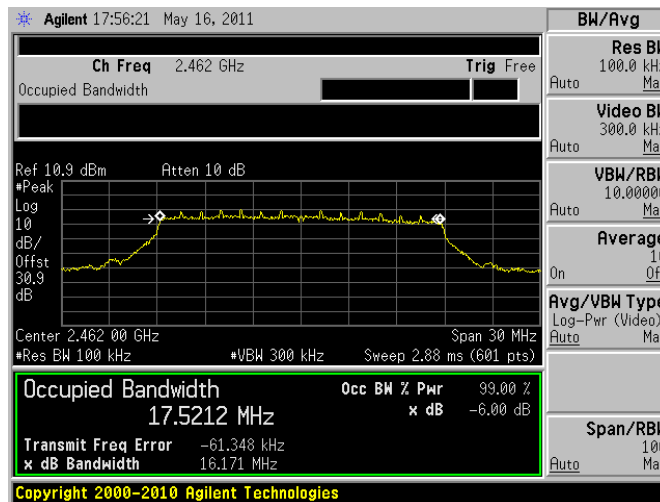



**5.8 GHz Band (5745-5825 MHz): BPSK with 5 MHz bandwidth**

Antenna #1:

EIRP +30 dBm ~ Low Channel

EIRP +30 dBm ~ Middle Channel

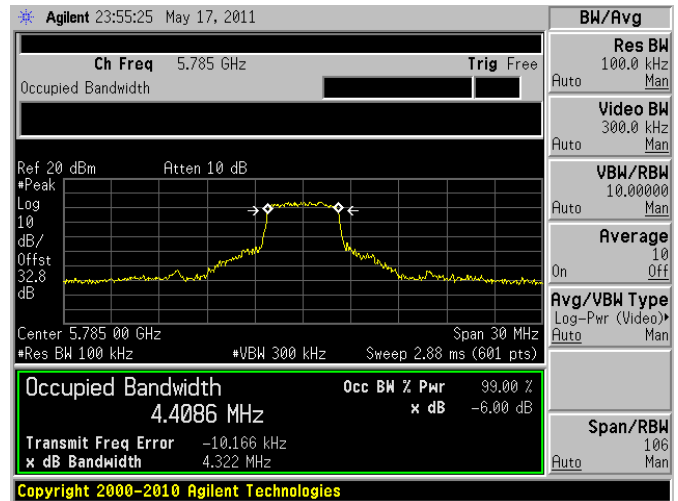
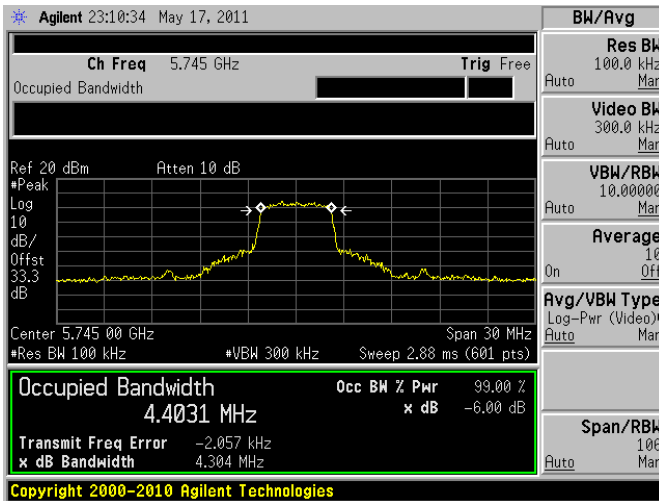

EIRP +30 dBm ~ High Channel

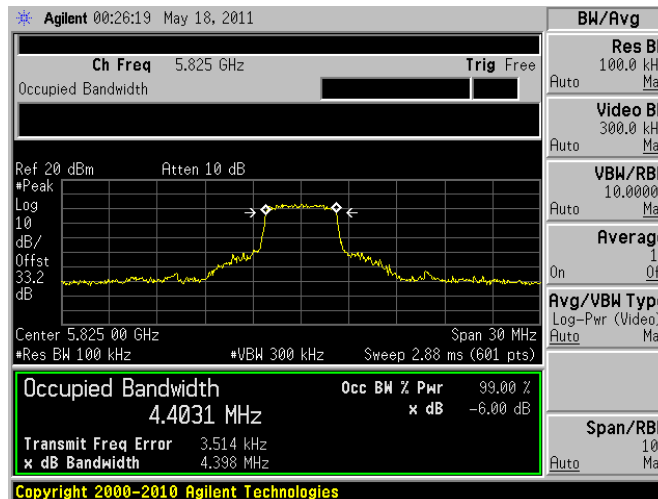

Antenna #2:

EIRP +30 dBm ~ Low Channel

EIRP +30 dBm ~ Middle Channel

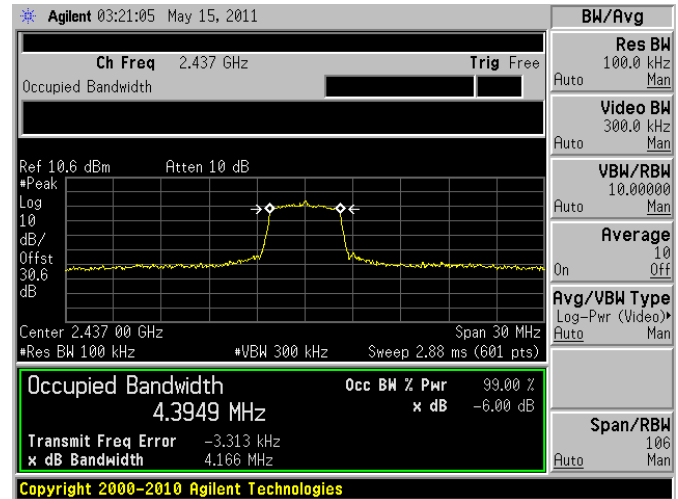
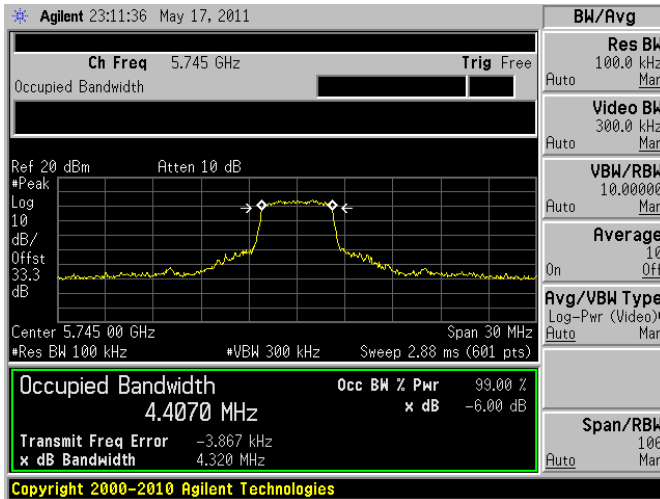

EIRP +30 dBm ~ High Channel

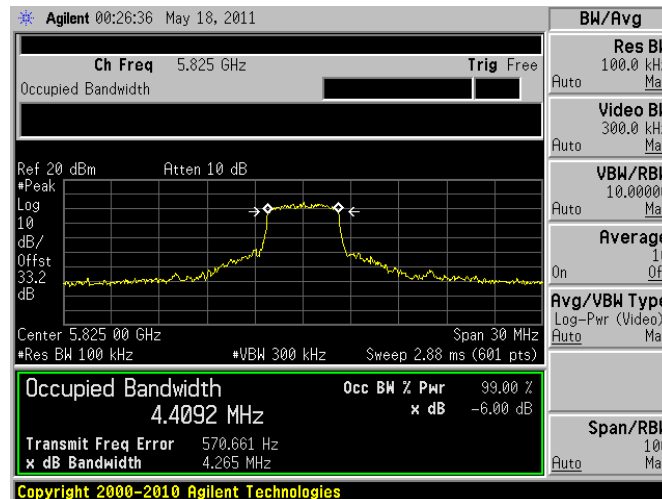

Antenna #3:

EIRP +30 dBm ~ Low Channel

EIRP +30 dBm ~ Middle Channel

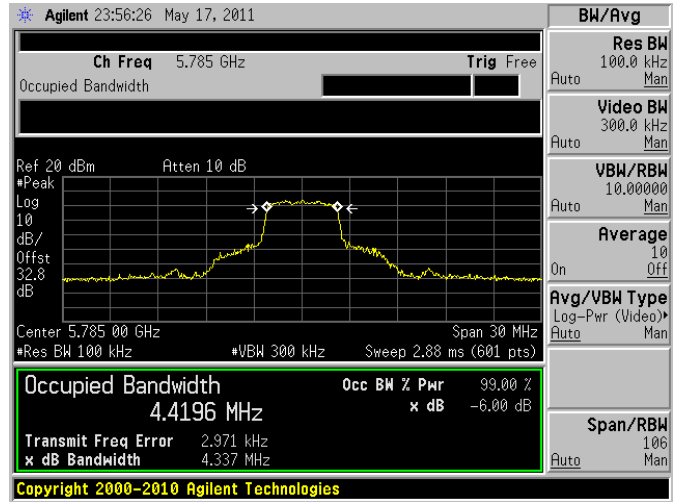
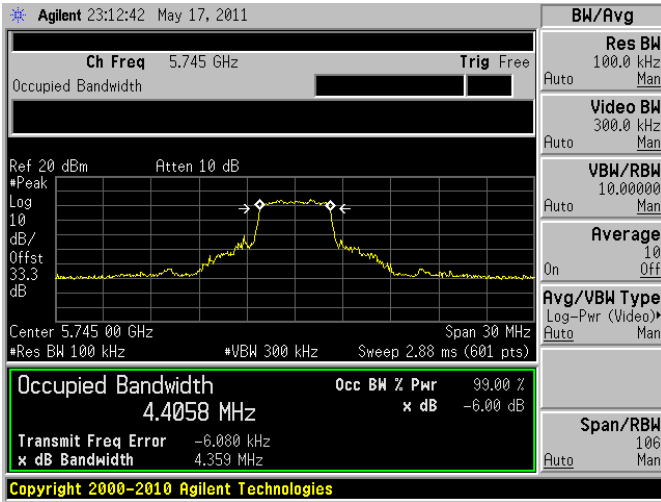

EIRP +30 dBm ~ High Channel

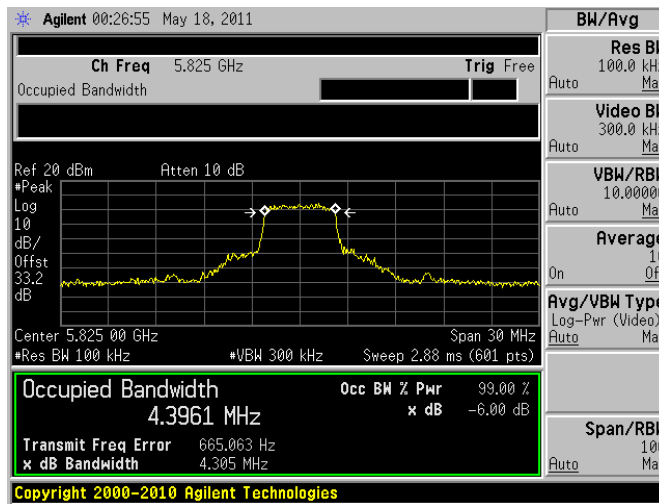

Antenna #4:

EIRP +30 dBm ~ Low Channel

EIRP +30 dBm ~ Middle Channel

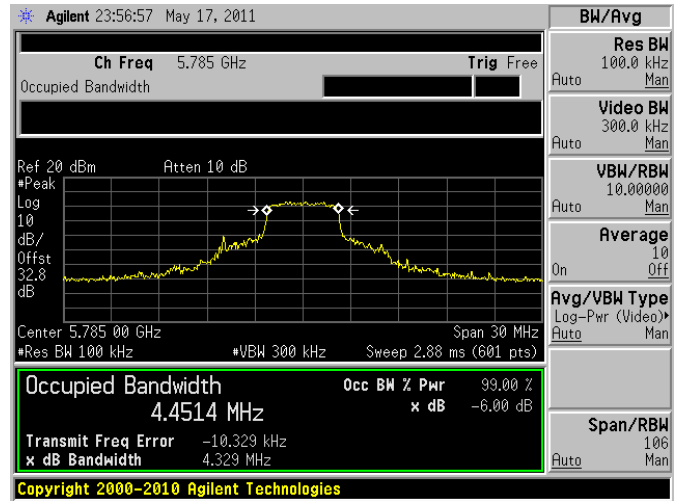
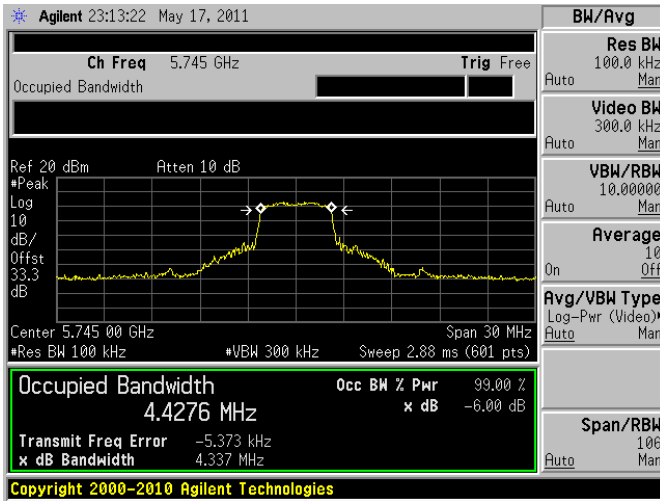

EIRP +30 dBm ~ High Channel

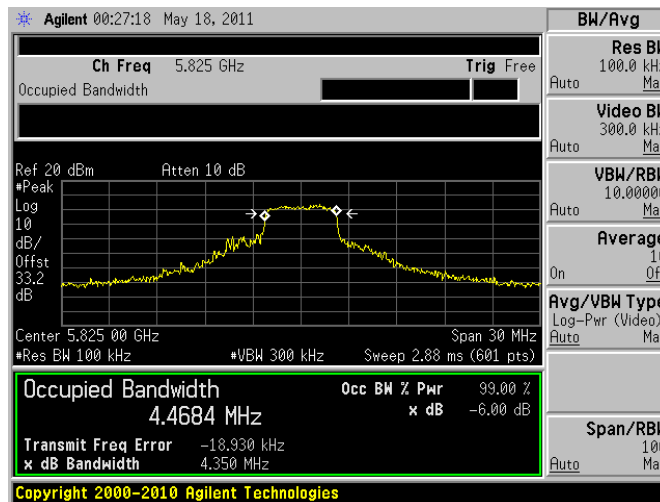

**5.8 GHz Band (5745-5825 MHz): BPSK with 20 MHz bandwidth**

Antenna #1:

EIRP +30 dBm ~ Low Channel

EIRP +30 dBm ~ Middle Channel

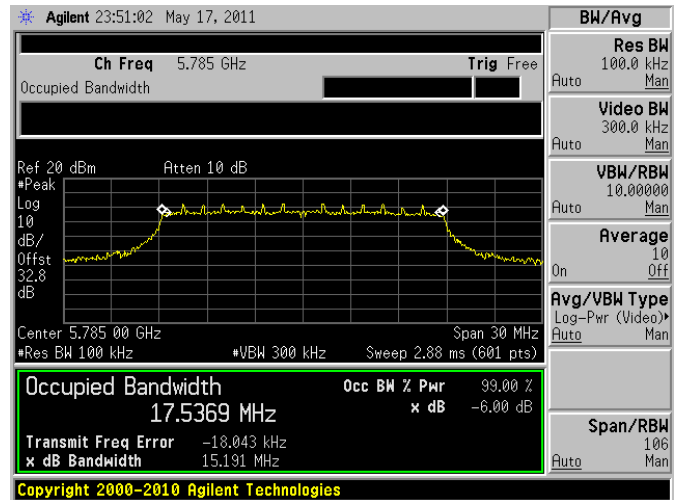
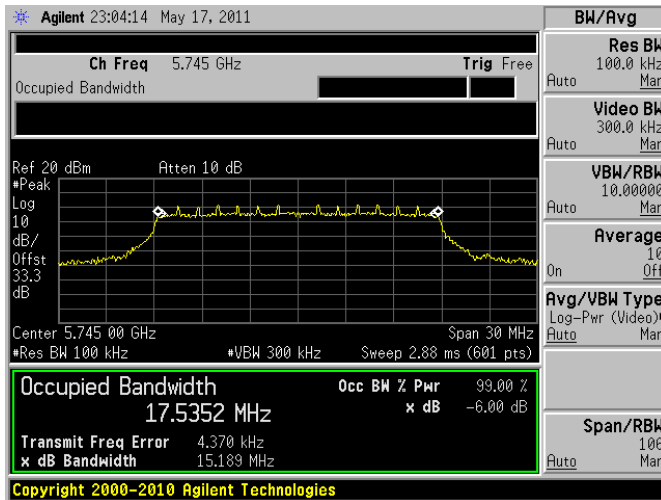

EIRP +30 dBm ~ High Channel

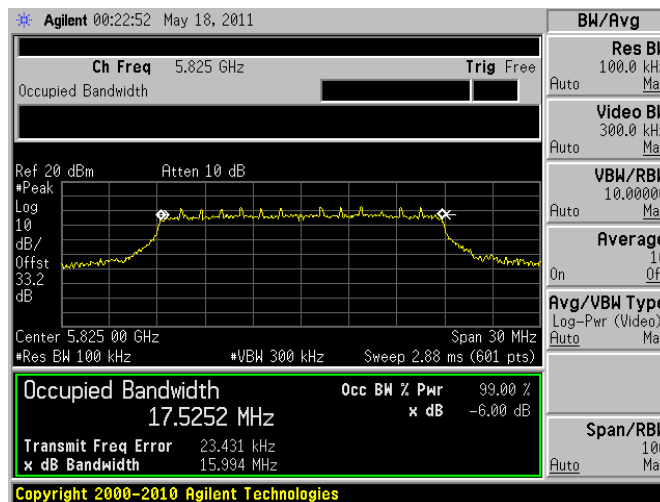

Antenna #2:

EIRP +30 dBm ~ Low Channel

EIRP +30 dBm ~ Middle Channel

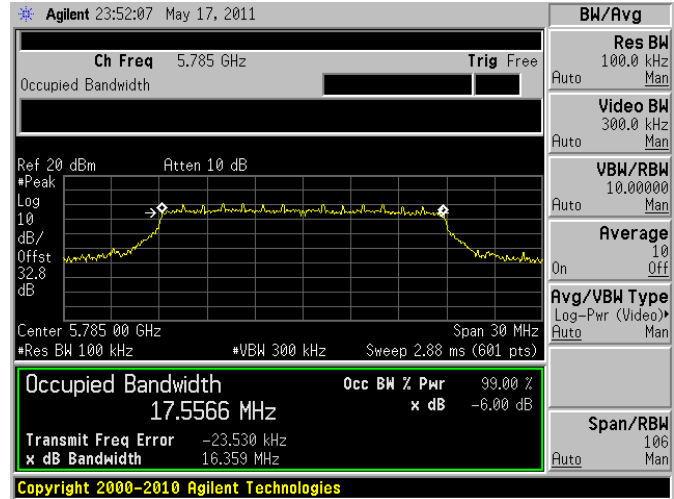
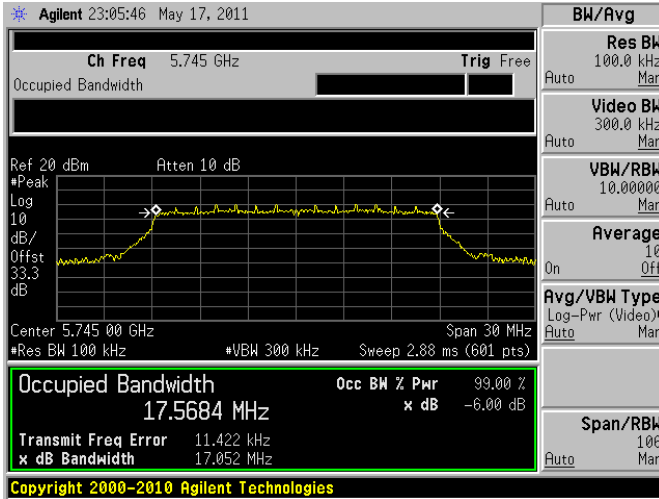

EIRP +30 dBm ~ High Channel

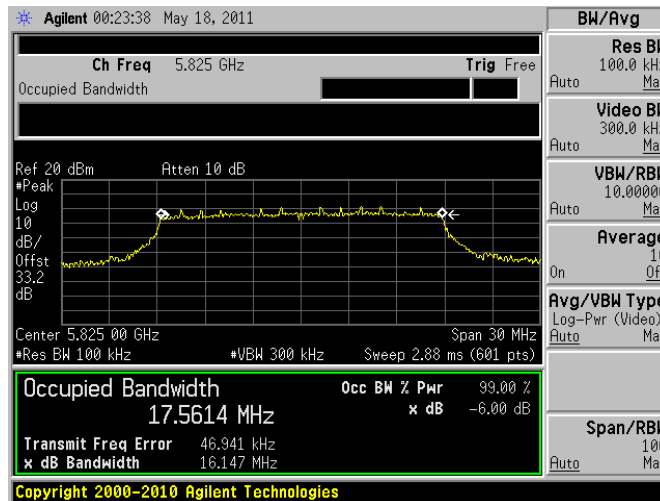

Antenna #3:

EIRP +30d Bm ~ Low Channel

EIRP +30 dBm ~ Middle Channel

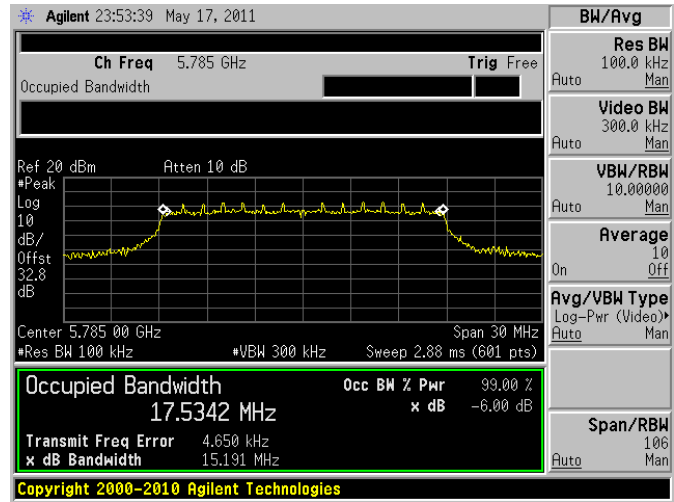
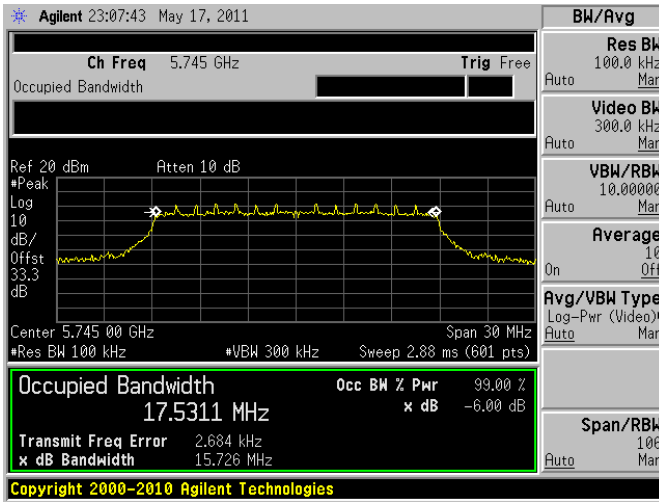

EIRP +30 dBm ~ High Channel

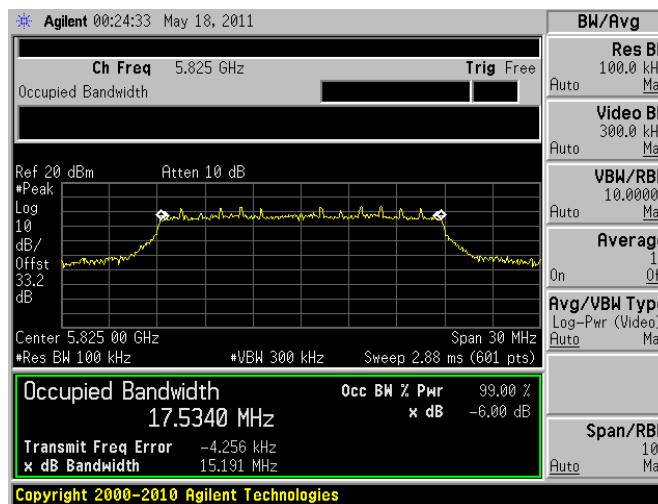

Antenna #4:

EIRP +30 dBm ~ Low Channel

EIRP +30 dBm ~ Middle Channel

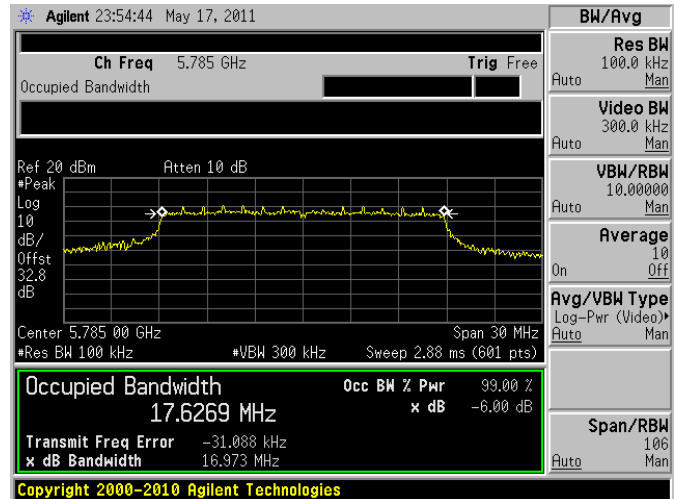
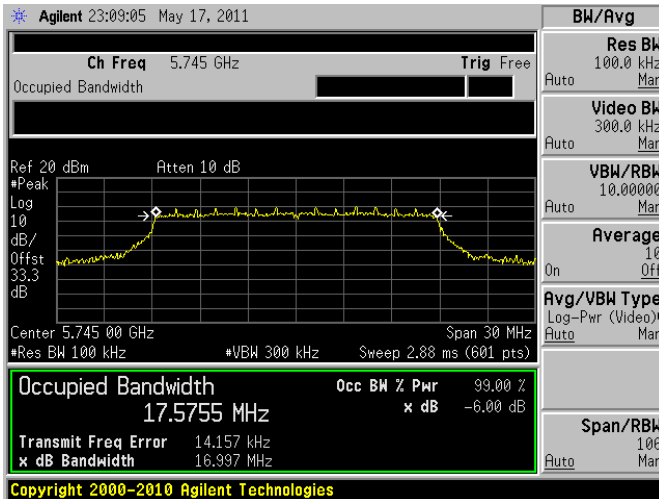

EIRP +30 dBm ~ High Channel

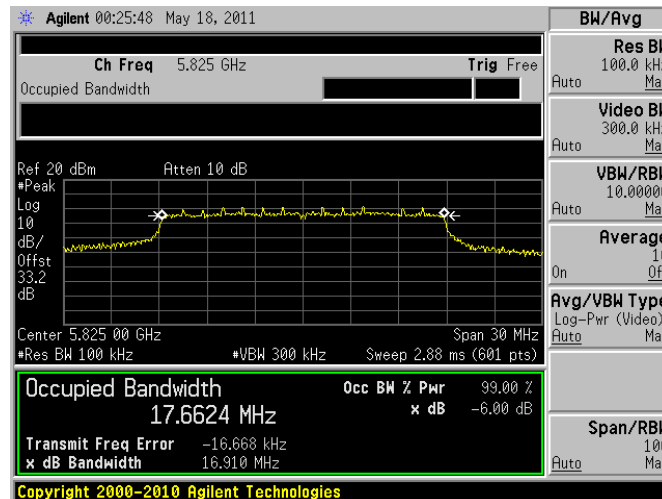



## 10 FCC §15.247(b) & IC RSS-210 §A8.4 - Peak Output Power Measurement

### 10.1 Applicable Standard

According to §15.247(b) (3) and RSS210 § A8.4 (4) for systems using digital modulation in the 902–928 MHz, 2400–2483.5 MHz, and 5725–5850 MHz bands: 1 Watt.

According to FCC 15.247(c)(2)(ii)(B) - "A lower value for the directional gain than that calculated in paragraph (c)(2)(ii)(A) of this section will be accepted if sufficient evidence is presented, e.g., due to shading of the array or coherence loss in the beam forming."

According to FCC KDB Doc "662911 D01 Multiple Transmitter Output v01" 4/4/2011 - "Emissions Testing of Transmitters with Multiple Outputs in the Same Band (e.g., MIMO, Smart Antenna, etc)" - "Directional Gain Calculations: If all transmit signals are completely uncorrelated with each other, Directional Gain = Gant"

### 10.2 Measurement Procedure

1. Place the EUT on a bench and set it in transmitting mode.
2. Remove the antenna from the EUT and then connect a low loss RF cable from the antenna port to a spectrum analyzer.
3. Add a correction factor to the display.

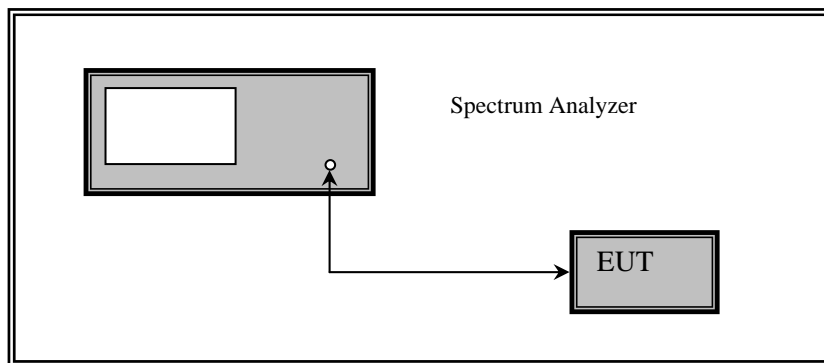

### 10.3 Test Equipment List and Details

Manufacturers	Description	Models	Serial Numbers	Calibration Dates
Agilent	Spectrum Analyzer	E4445A	MY44020562	2011-04-05

**Statement of Traceability:** BACL Corp. attests that all calibrations have been performed per the NVLAP requirements, traceable to the NIST.

## 10.4 Test Environmental Conditions

<b>Temperature:</b>	16.5~27°C
<b>Relative Humidity:</b>	30.9~43.3 %
<b>ATM Pressure:</b>	101-103 kPa

The testing was performed by Brian Fox on 2011-05-13 ~ 2011-05-20.

## 10.5 Test Results

(1) 2.4 GHz Band, BPSK with 5 MHz Bandwidth, +20 dBm EIRP Power setting

Antenna Gain 14 dBi (4 x Directional Array): Directional gain = 14 dBi + 10\*Log (4) = 20 dBi, so the Power limit should be 30 dBm-(20-6) dBi = 16 dBm

Frequency (MHz)	Conducted Output Power (dBm)				Total Power (dBm)	Limit (dBm)
	Ant 1	Ant 2	Ant 3	Ant 4		
2412	-0.4	-0.8	-0.8	-0.7	4.11	16
2437	-0.9	-0.4	-1.0	-0.7	4.01	16
2462	-0.6	-0.5	-0.3	-0.6	4.31	16

(2) 2.4 GHz Band, BPSK with 20 MHz Bandwidth, +20 dBm EIRP Power setting

Antenna Gain 14 dBi (4 x Directional Array): Directional gain = 14 dBi + 10\*Log (4) = 20 dBi, so the Power limit should be 30 dBm-(20-6) dBi = 16 dBm

Frequency (MHz)	Conducted Output Power (dBm)				Total Power (dBm)	Limit (dBm)
	Ant 1	Ant 2	Ant 3	Ant 4		
2412	-0.5	-0.7	-0.7	-0.4	4.14	16
2437	-0.7	-0.8	-0.8	-0.9	4.00	16
2462	-0.3	-0.3	-0.3	-0.8	4.47	16

(3) 2.4 GHz Band, BPSK with 5 MHz Bandwidth, +30 dBm EIRP Power setting

Antenna Gain 14dBi (4 x Directional Array): Directional gain = 14 dBi + 10\*Log (4) = 20 dBi, so the Power limit should be 30 dBm-(20-6) dBi = 16 dBm

Frequency (MHz)	Conducted Output Power (dBm)				Total Power (dBm)	Limit (dBm)
	Ant 1	Ant 2	Ant 3	Ant 4		
2412	9.8	9.5	9.2	9.3	14.28	16
2437	9.1	9.3	9.3	9.2	14.01	16
2462	9.4	9.1	9.6	9.4	14.14	16

## (4) 2.4 GHz Band, BPSK with 20 MHz Bandwidth, +30 dBm EIRP Power setting

Antenna Gain 14 dBi (4 x Directional Array): Directional gain = 14 dBi + 10\*Log (4) = 20 dBi, so the Power limit should be 30 dBm-(20-6) dBi = 16 dBm

Frequency (MHz)	Conducted Output Power (dBm)				Total Power (dBm)	Limit (dBm)
	Ant 1	Ant 2	Ant 3	Ant 4		
2412	9.8	9.9	9.4	9.4	14.48	16
2437	9.3	9.6	9.6	9.2	14.27	16
2462	9.2	9.5	9.6	9.4	14.21	16

## (5) 2.4 GHz Band, BPSK with 5 MHz Bandwidth, MIMO +36 dBm EIRP Power setting

Antenna Gain 14 dBi (4 x Directional Array): 4xMIMO Directional gain = 14 dBi + 10\*Log (4/4) = 14 dBi, so the power limit should be 30 dBm-(14-6) dBi = 22 dBm

Frequency (MHz)	Conducted Output Power (dBm)				Total Power (dBm)	Limit (dBm)
	Ant 1	Ant 2	Ant 3	Ant 4		
2412	15.5	15.2	15.6	15.4	21.4	22
2437	15.3	15.2	15.4	15.5	21.4	22
2462	15.4	15.1	15.5	15.6	21.4	22

## (6) 2.4 GHz Band, BPSK with 20 MHz Bandwidth, MIMO +36 dBm EIRP Power setting

Antenna Gain 14 dBi (4 x Directional Array): 4xMIMO Directional gain = 14 dBi + 10\*Log (4/4) = 14 dBi, so the power limit should be 30 dBm-(14-6) dBi = 22 dBm

Frequency (MHz)	Conducted Output Power (dBm)				Total Power (dBm)	Limit (dBm)
	Ant 1	Ant 2	Ant 3	Ant 4		
2412	15.4	15.3	15.8	15.4	21.5	22
2437	15.4	15.5	15.6	15.3	21.5	22
2462	15.1	15.4	15.6	15.5	21.4	22

## (7) 5.8 GHz Band, BPSK with 5 MHz Bandwidth, +30 dBm EIRP Power setting

Antenna Gain 12 dBi (4 x Omni Array): Directional gain = 12 dBi + 10\*Log (4) = 18 dBi, so the Power limit should be 30 dBm-(18-6) dBi = 18 dBm

Frequency (MHz)	Conducted Output Power (dBm)				Total Power (dBm)	Limit (dBm)
	Ant 1	Ant 2	Ant 3	Ant 4		
5745	11.4	11.8	11.7	11.6	16.41	18
5785	11.2	11.6	11.4	11.3	16.17	18
5825	11.1	11.3	11.5	11.2	16.07	18

## (8) 5.8 GHz Band, BPSK with 20 MHz Bandwidth, +30 dBm EIRP Power setting

Antenna Gain 12 dBi (4 x Omni Array): Directional gain = 12 dBi + 10\*Log (4) = 18 dBi, so the Power limit should be 30 dBm-(18-6) dBi = 18 dBm

Frequency (MHz)	Conducted Output Power (dBm)				Total Power (dBm)	Limit (dBm)
	Ant 1	Ant 2	Ant 3	Ant 4		
5745	11.2	11.2	11.3	11.3	16.00	18
5785	11.6	11.1	11.6	11.4	16.21	18
5825	11.4	11.5	11.7	11.4	16.31	18

## (9) 5.8 GHz Band, BPSK with 5 MHz Bandwidth, MIMO +36 dBm EIRP Power setting

Antenna Gain 12 dBi (4 x Omni Array): Directional gain = 12 dBi + 10\*Log (4/4) = 12 dBi, so the Power limit should be 30 dBm-(12-6) dBi = 24 dBm

Frequency (MHz)	Conducted Output Power (dBm)				Total Power (dBm)	Limit (dBm)
	Ant 1	Ant 2	Ant 3	Ant 4		
5745	17.2	17.7	17.5	17.2	22.24	24
5785	17.6	17.2	17.2	17.4	22.11	24
5825	17.2	17.6	16.6	15.0	21.92	24

## (10) 5.8 GHz Band, BPSK with 20 MHz Bandwidth, MIMO +36 dBm EIRP Power setting

Antenna Gain 12 dBi (4 x Omni Array): Directional gain = 12 dBi + 10\*Log (4/4) = 12 dBi, so the Power limit should be 30 dBm-(12-6) dBi = 24 dBm

Frequency (MHz)	Conducted Output Power (dBm)				Total Power (dBm)	Limit (dBm)
	Ant 1	Ant 2	Ant 3	Ant 4		
5745	17.4	17.2	17.6	17.3	22.17	24
5785	17.2	17.3	17.5	15.6	22.11	24
5825	17.4	17.8	16.8	15.1	22.12	24

Please refer to the following plots for detailed results

**2.4 GHz (2412–2462 MHz) Band**

**2.4 GHz, Antenna #1:**

**BPSK with 5 MHz Bandwidth**

EIRP +20 dBm ~ Low Channel

EIRP +20 dBm ~ Middle Channel

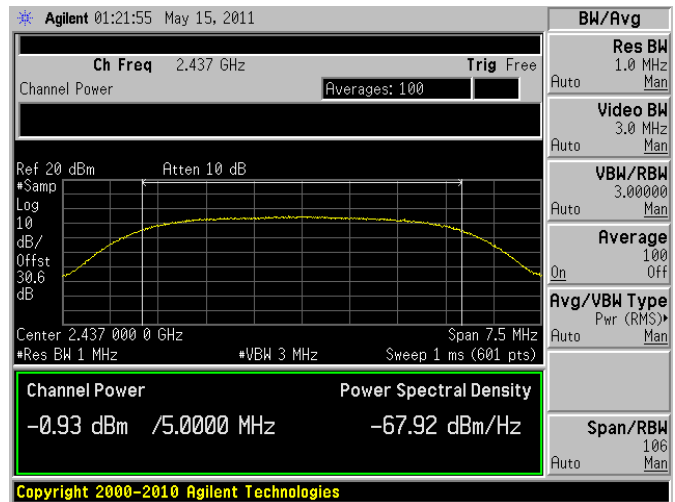
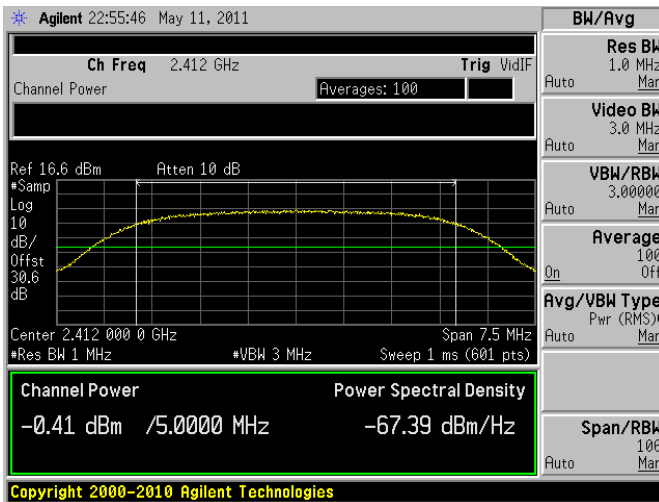

EIRP +20 dBm ~ High Channel

EIRP +30 dBm ~ Low Channel

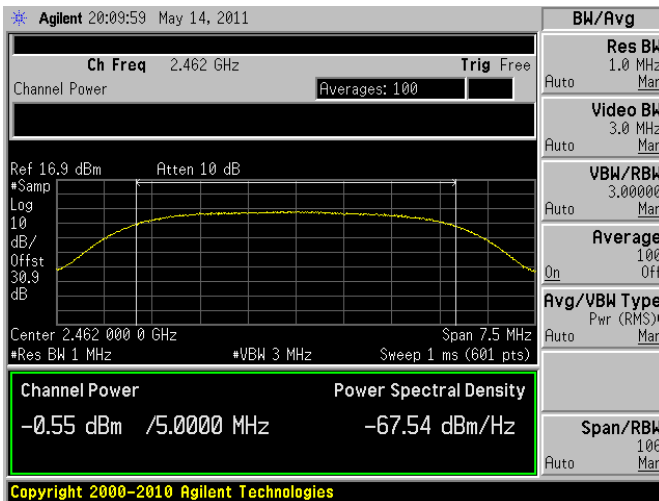

EIRP +30 dBm ~ Middle Channel

EIRP +30 dBm ~ High Channel

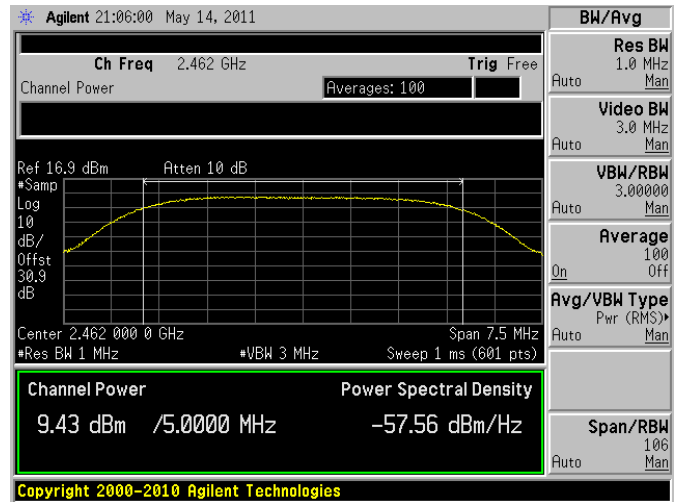
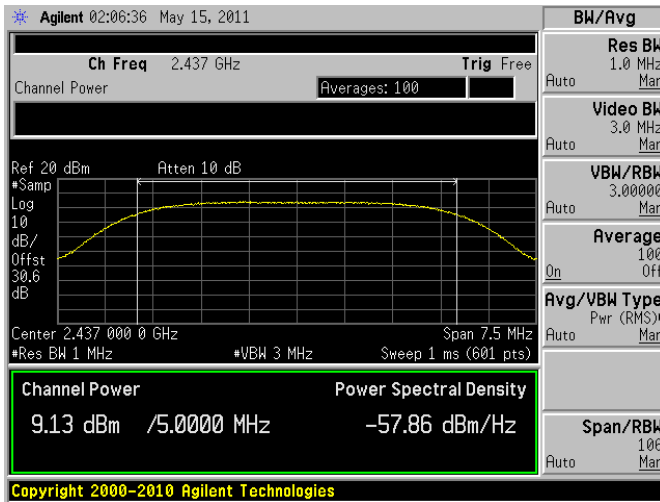

EIRP MIMO +36 dBm ~ Low Channel

EIRP MIMO +36 dBm ~ Middle Channel

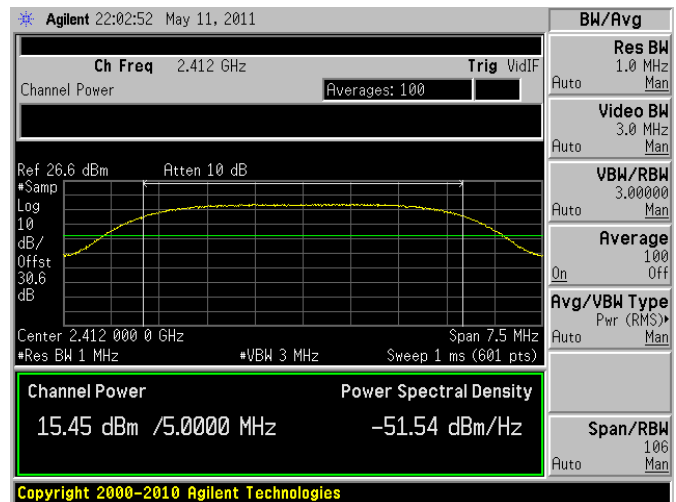
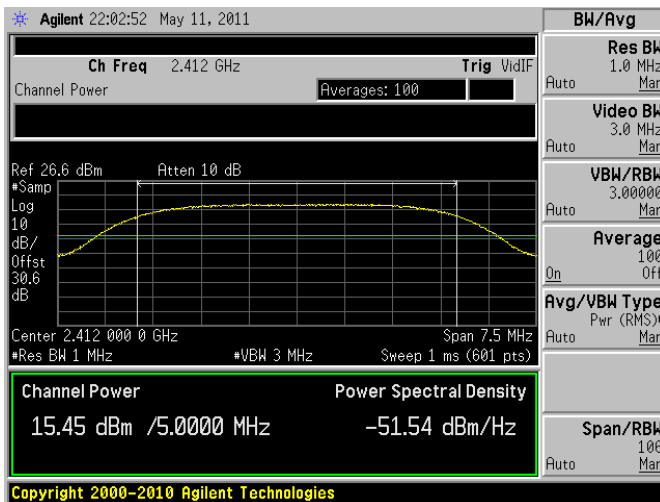

EIRP MIMO +36 dBm ~ High Channel

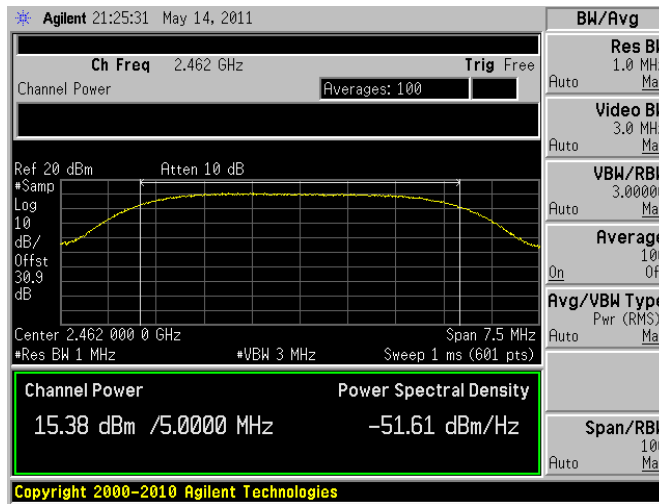

BPSK with 20 MHz Bandwidth

EIRP +20 dBm ~ Low Channel

EIRP +20 dBm ~ Middle Channel

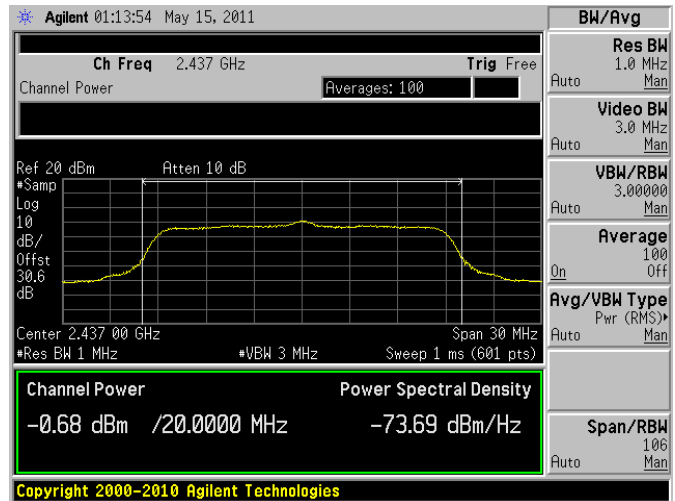
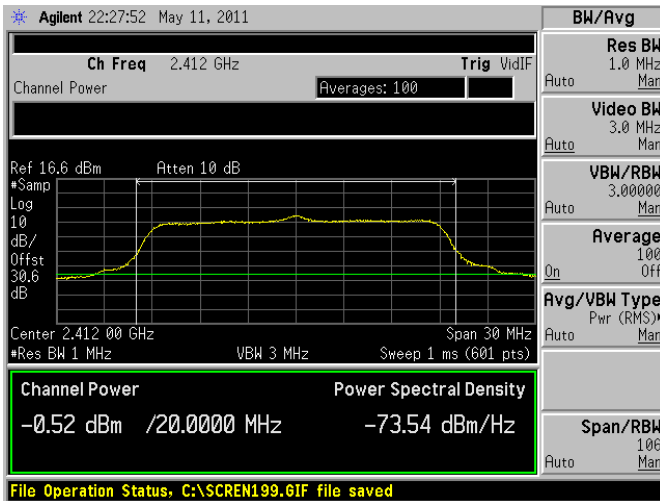

EIRP +20 dBm ~ High Channel

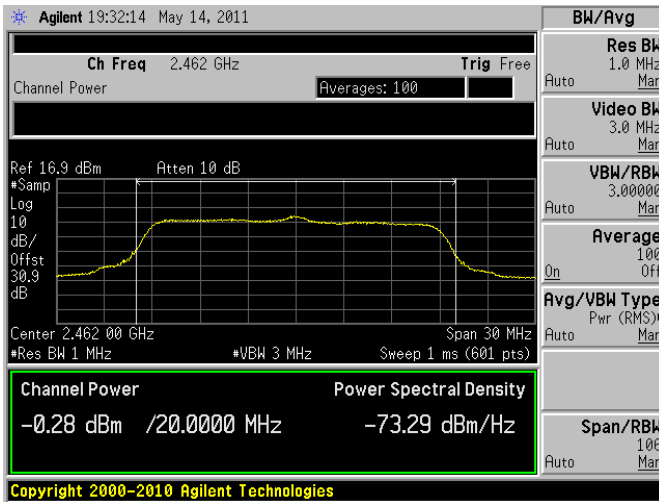

EIRP +30 dBm ~ Low Channel

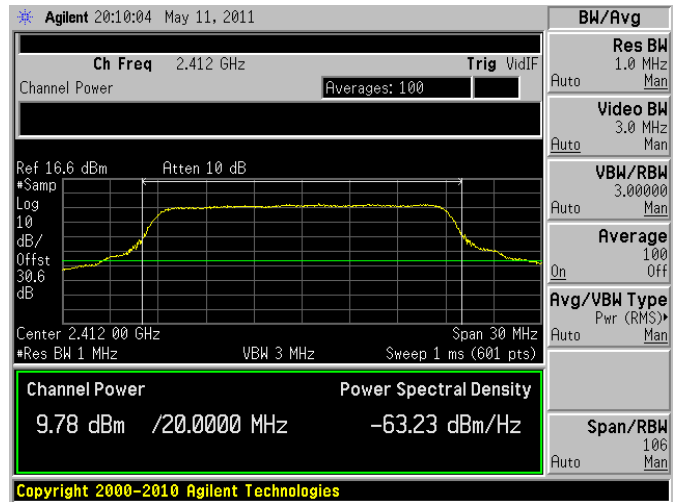

EIRP +30 dBm ~ Middle Channel

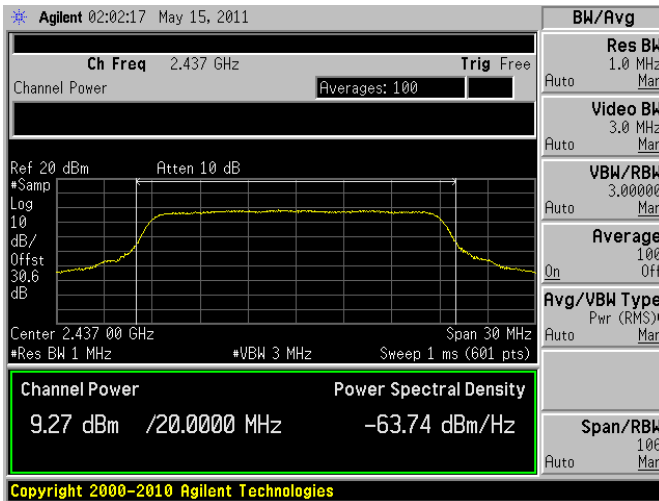

EIRP +30 dBm ~ High Channel

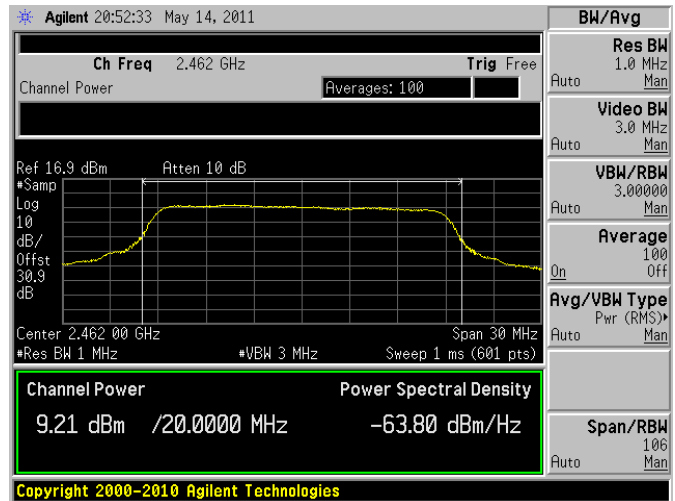

EIRP MIMO +36 dBm ~ Low Channel

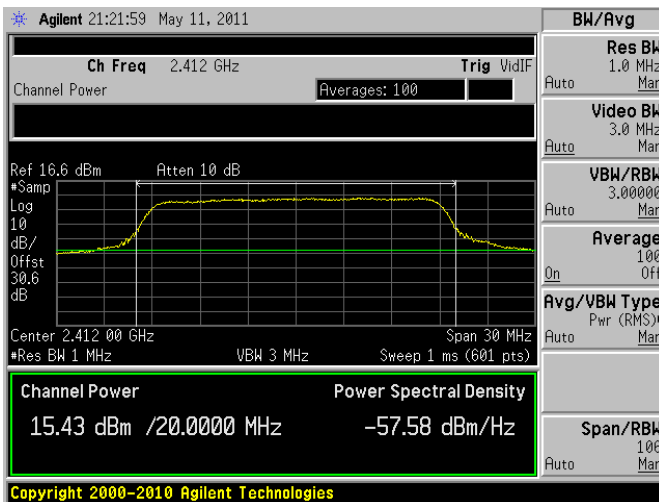

EIRP MIMO +36 dBm ~ Middle Channel

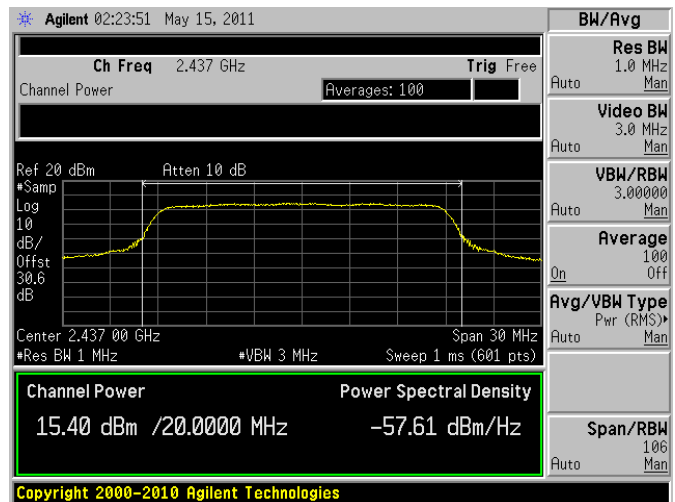



EIRP MIMO +36 dBm ~ High Channel

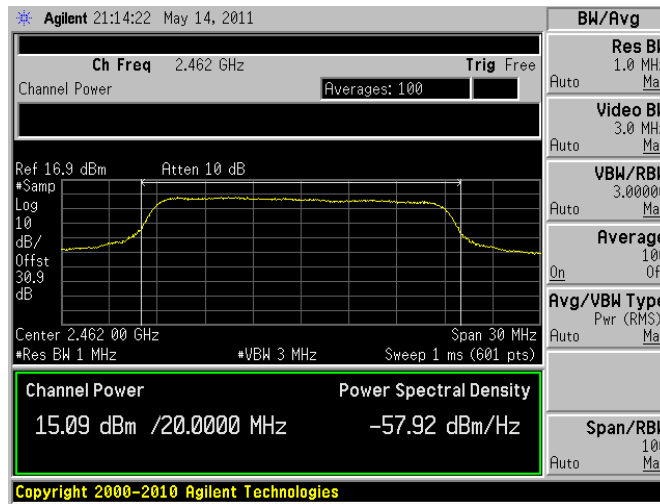

2.4 GHz, Antenna #2:

BPSK with 5 MHz Bandwidth

EIRP +20 dBm ~ Low Channel

EIRP +20 dBm ~ Middle Channel

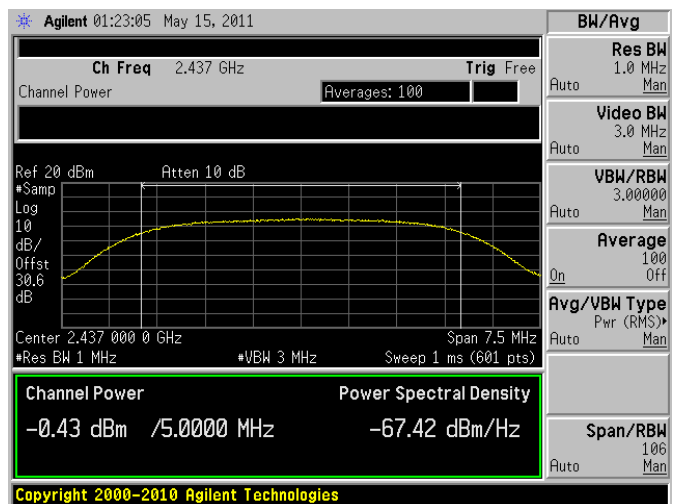
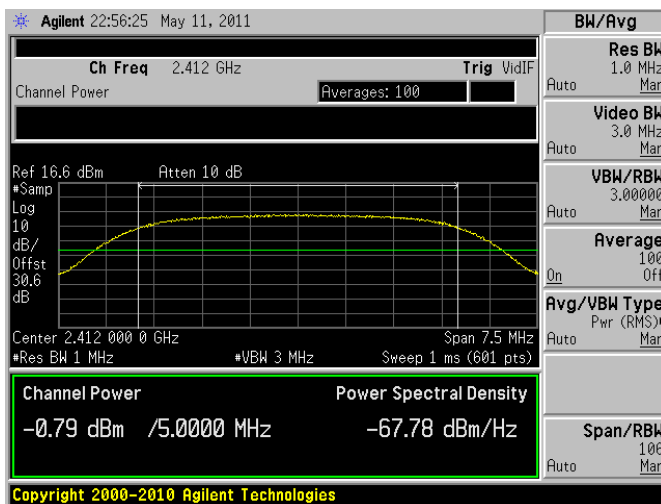

EIRP +20 dBm ~ High Channel

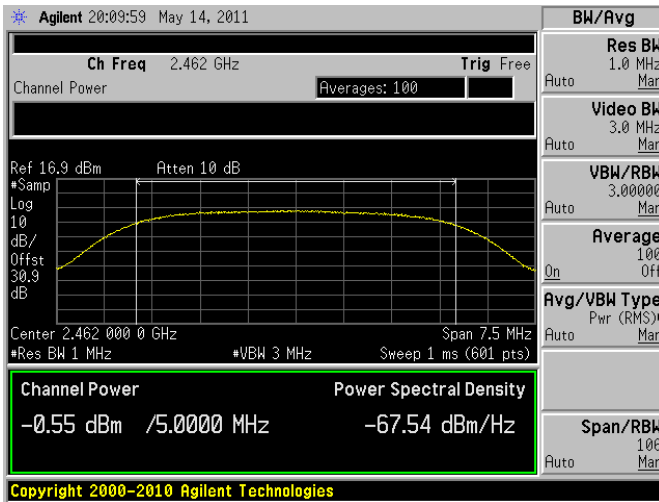

EIRP +30 dBm ~ Low Channel

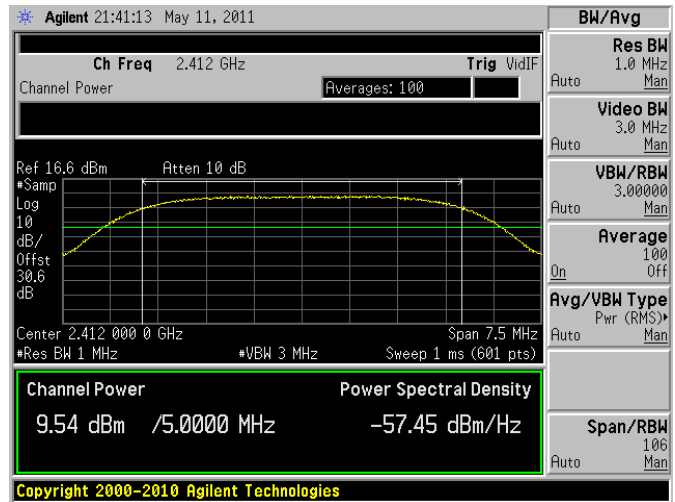

EIRP +30 dBm ~ Middle Channel

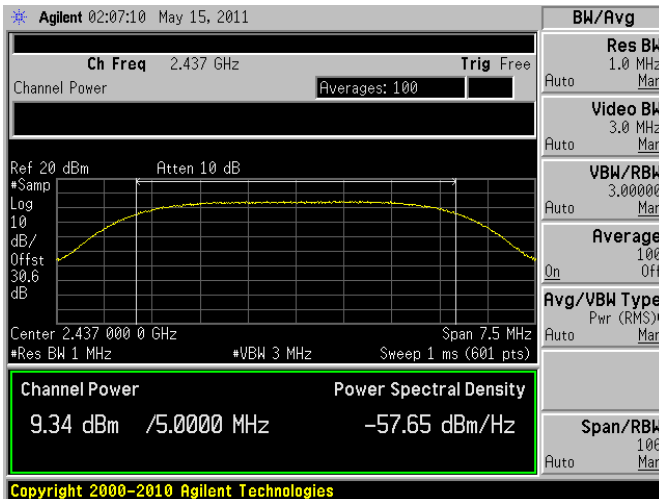

EIRP +30 dBm ~ High Channel

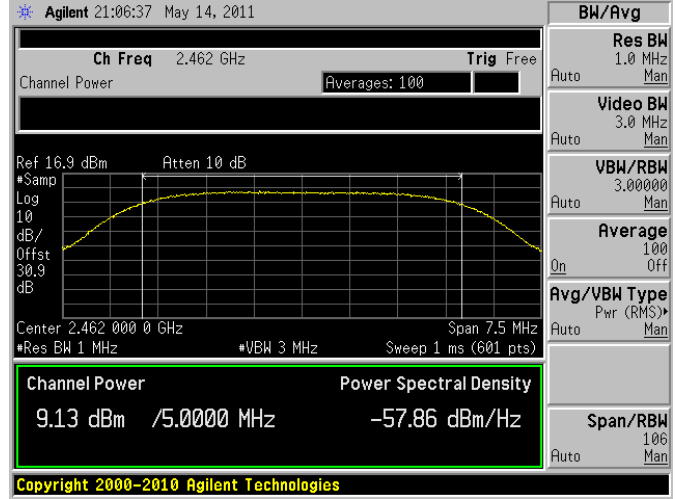

EIRP MIMO +36 dBm ~ Low Channel

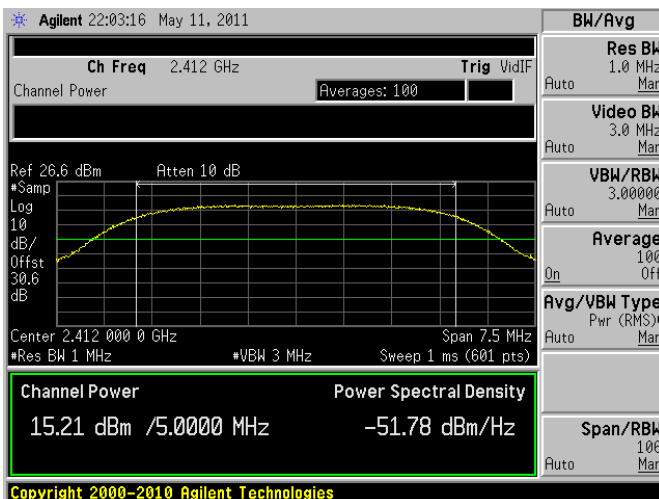

EIRP MIMO +36 dBm ~ Middle Channel

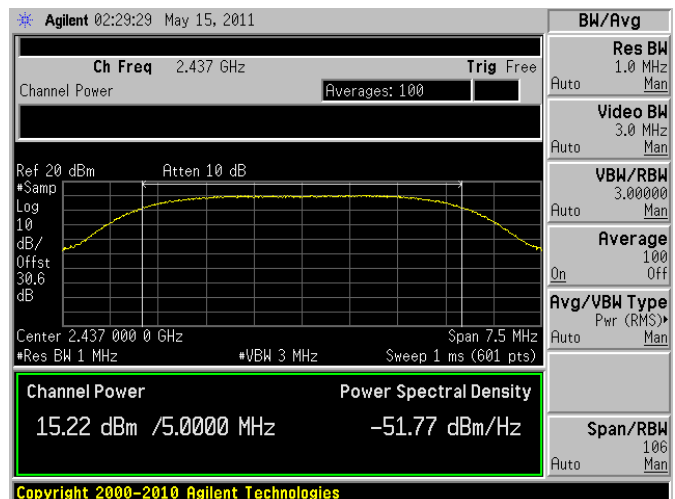

EIRP MIMO +36 dBm ~ High Channel

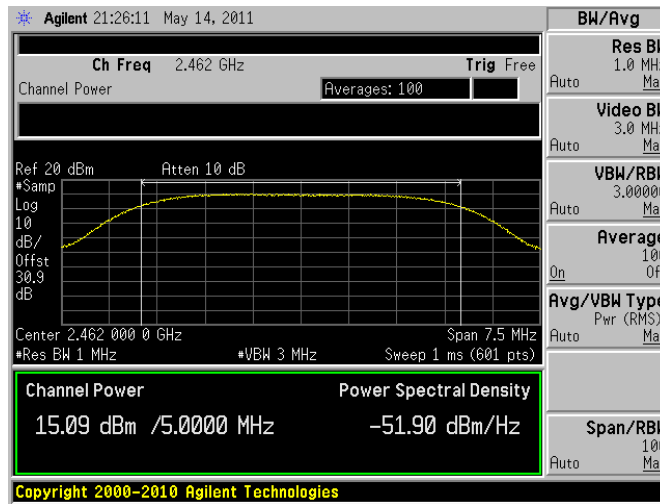

BPSK with 20 MHz Bandwidth

EIRP +20 dBm ~ Low Channel

EIRP +20 dBm ~ Middle Channel

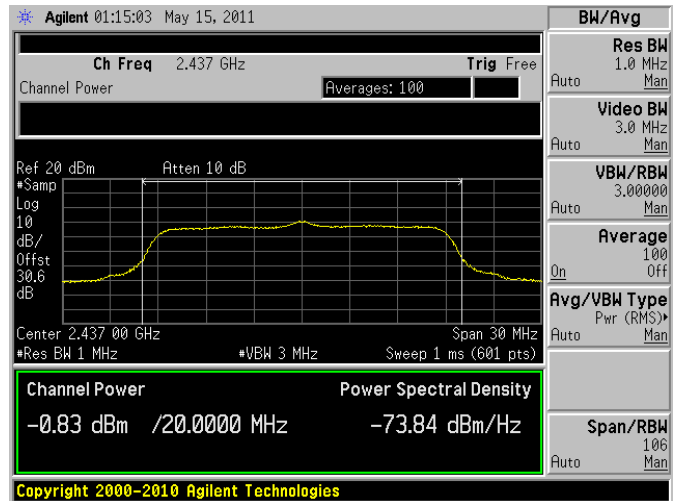
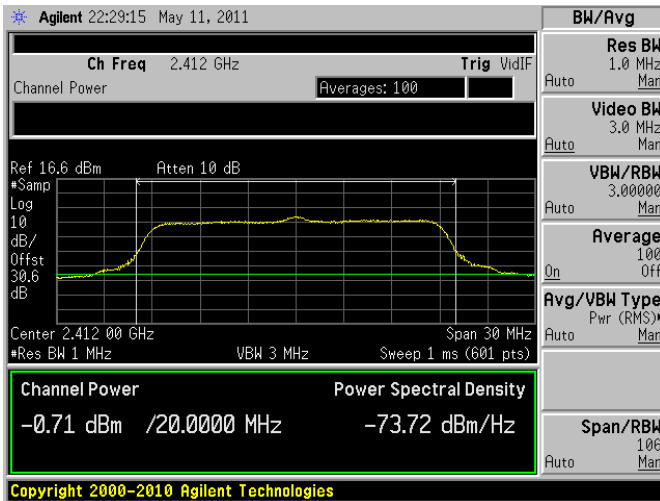

EIRP +20 dBm ~ High Channel

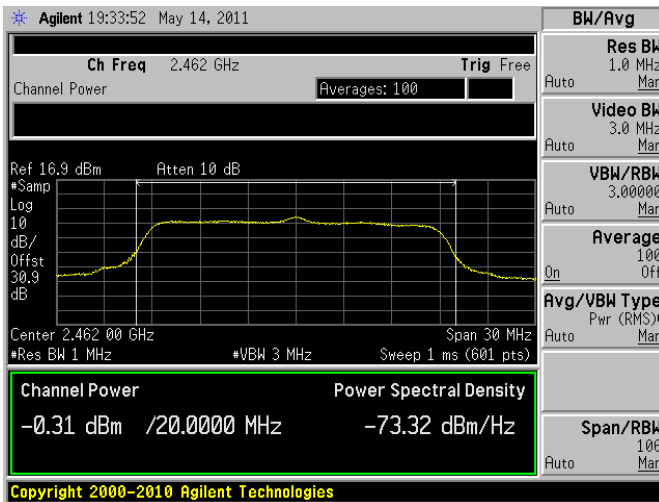

EIRP +30 dBm ~ Low Channel

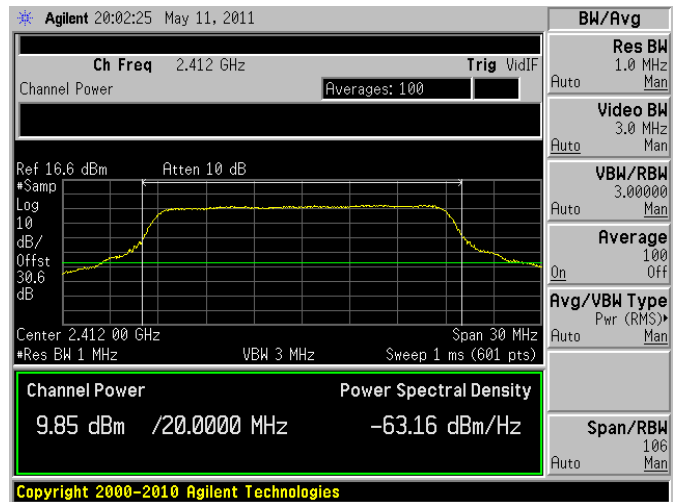

EIRP +30 dBm ~ Middle Channel

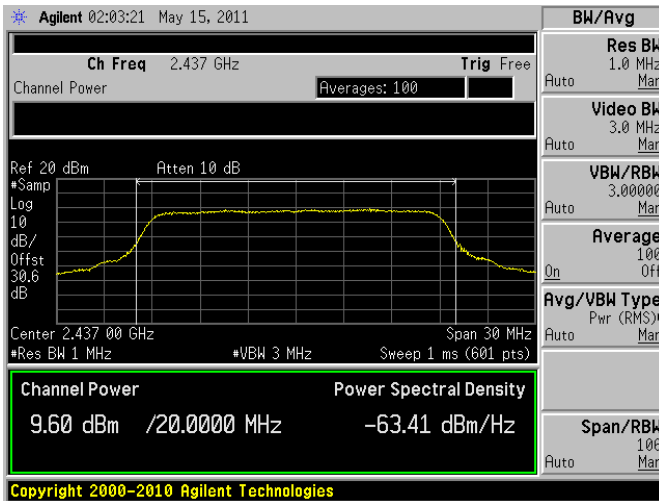

EIRP +30 dBm ~ High Channel

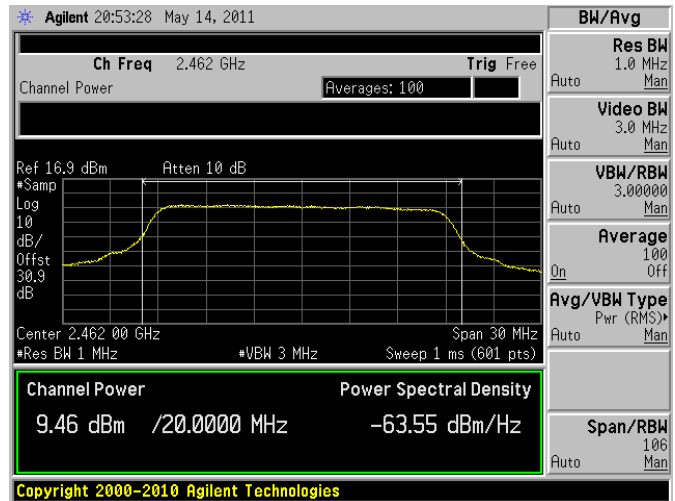

EIRP MIMO +36 dBm ~ Low Channel

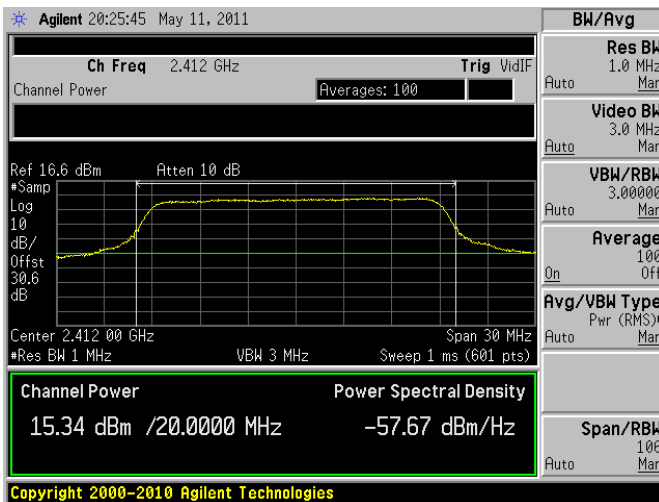

EIRP MIMO +36 dBm ~ Middle Channel

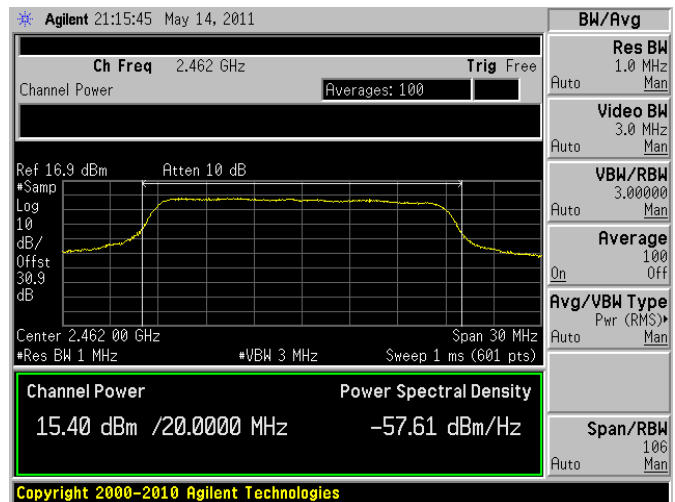

EIRP MIMO +36 dBm ~ High Channel

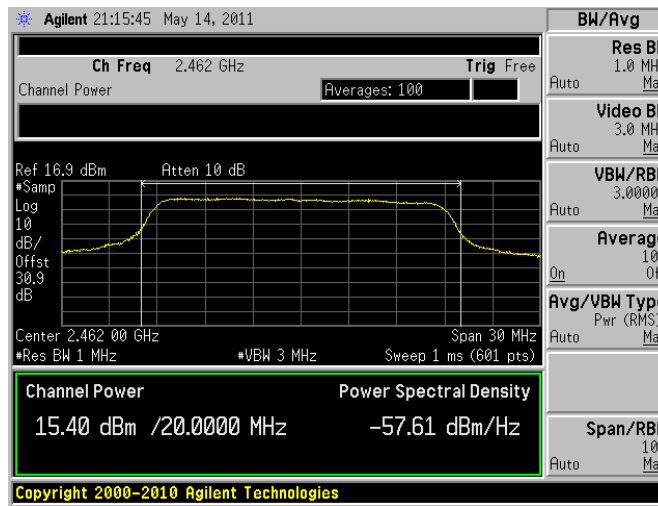

2.4 GHz, Antenna #3:

BPSK with 5 MHz Bandwidth

EIRP +20 dBm ~ Low Channel

EIRP +20 dBm ~ Middle Channel

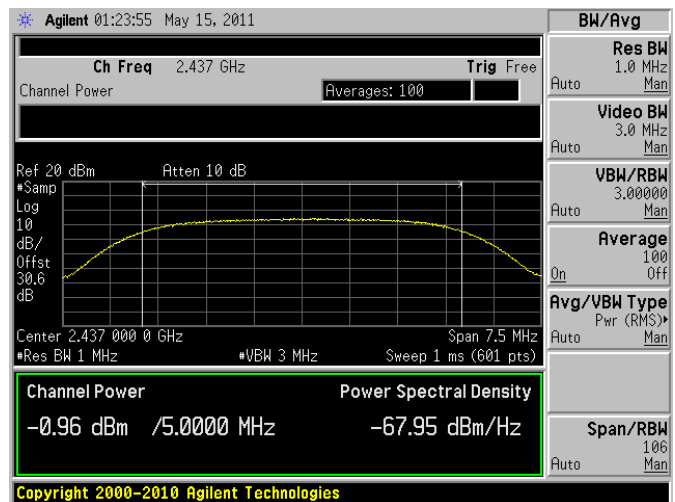
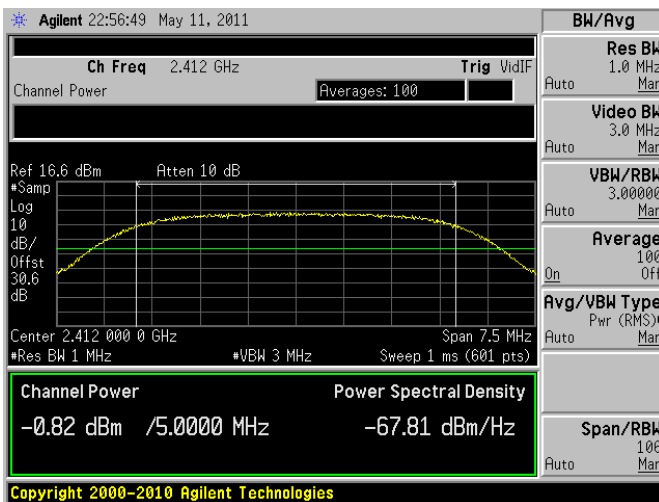

EIRP +20 dBm ~ High Channel

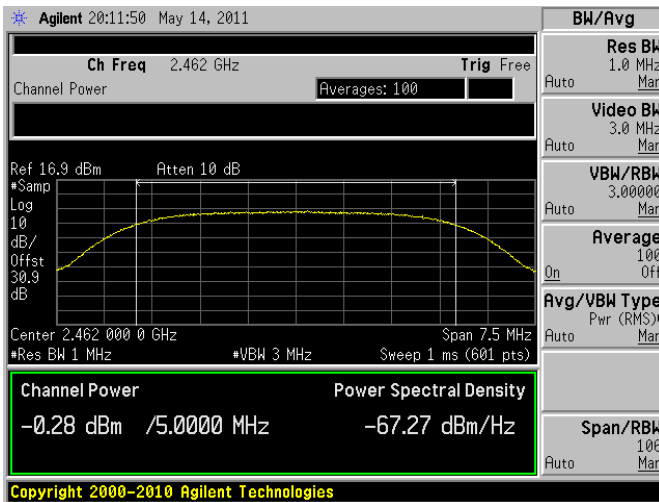

EIRP +30 dBm ~ Low Channel

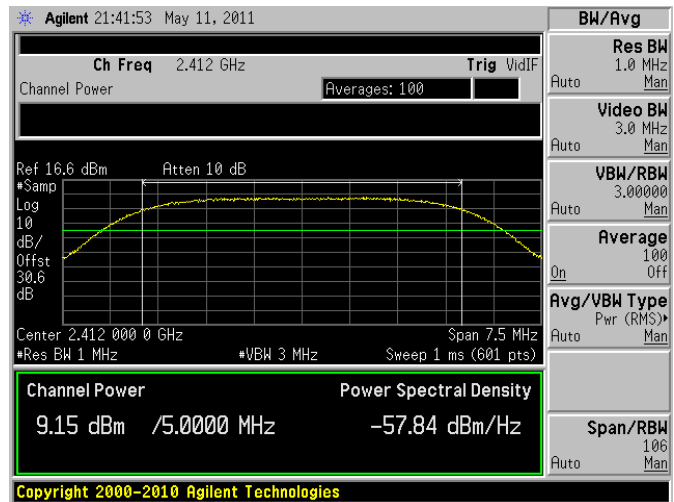

EIRP +30 dBm ~ Middle Channel

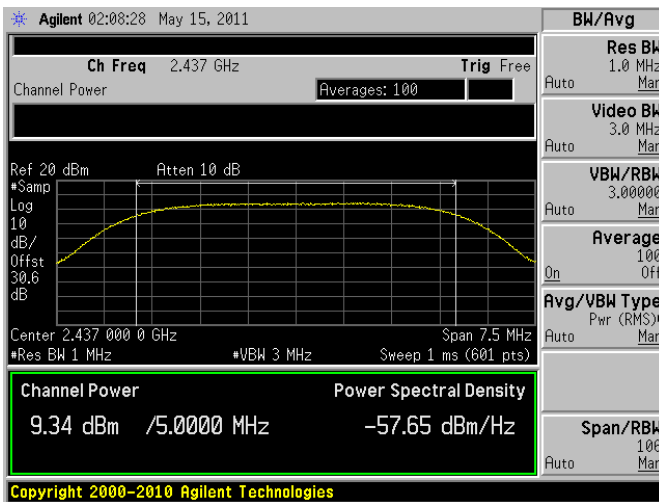

EIRP +30 dBm ~ High Channel

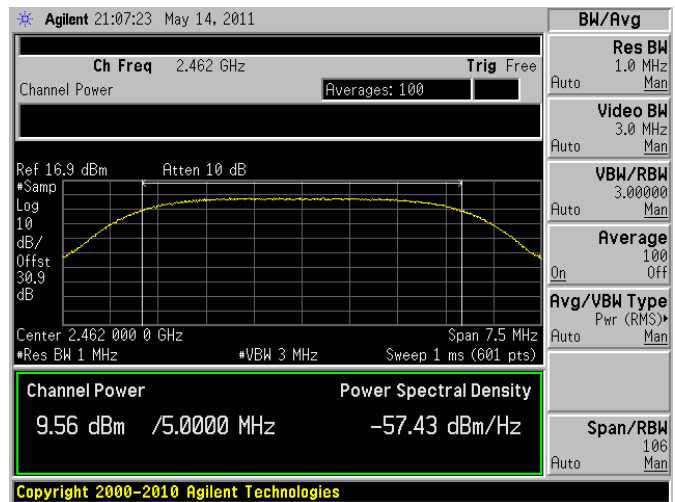

EIRP MIMO +36 dBm ~ Low Channel

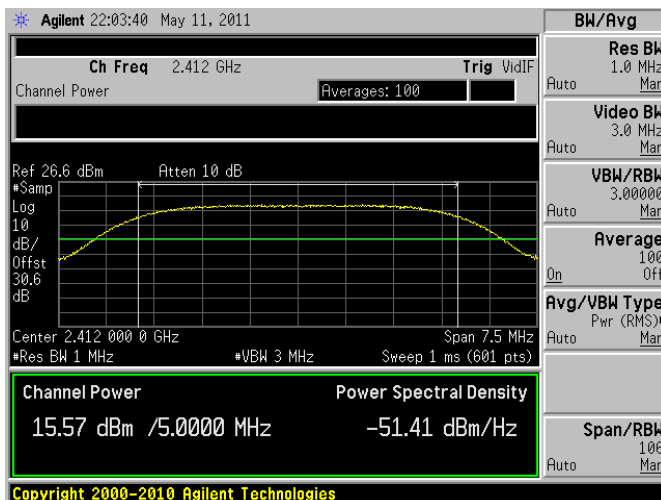

EIRP MIMO +36 dBm ~ Middle Channel

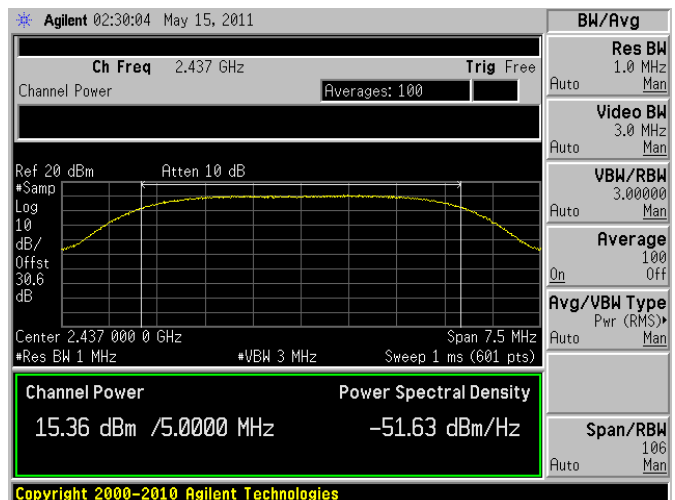

EIRP MIMO +36 dBm ~ High Channel

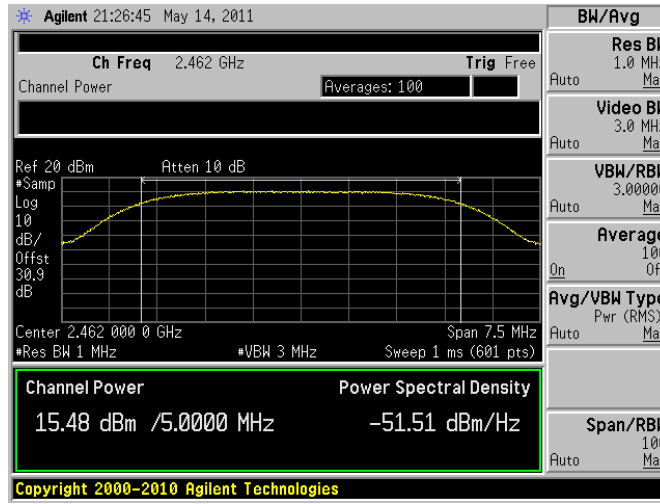

BPSK with 20 MHz Bandwidth

EIRP +20 dBm ~ Low Channel

EIRP +20 dBm ~ Middle Channel

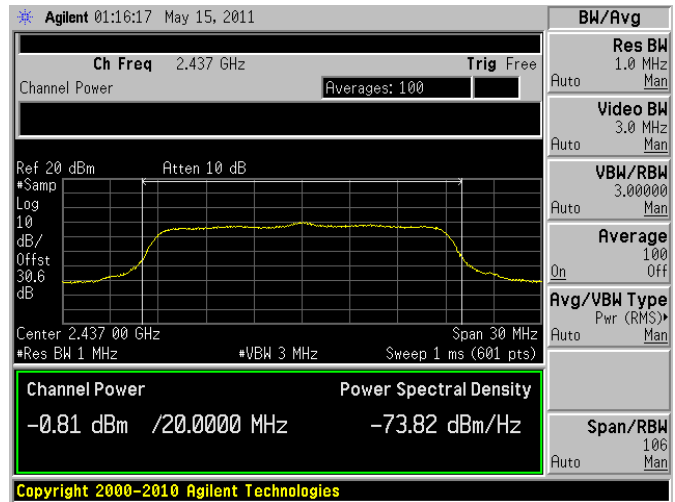
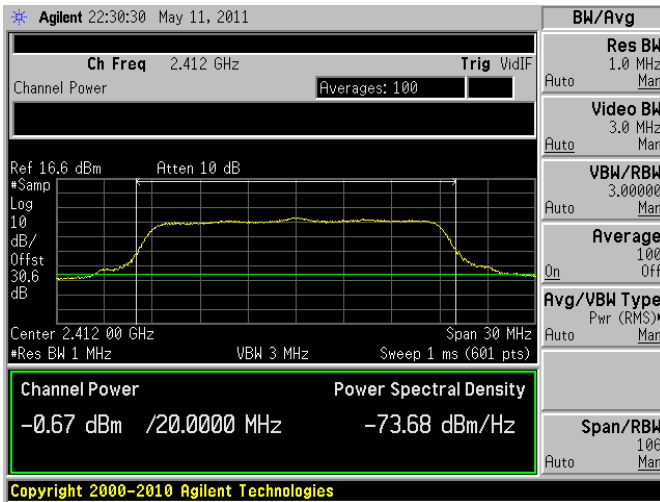

EIRP +20 dBm ~ High Channel

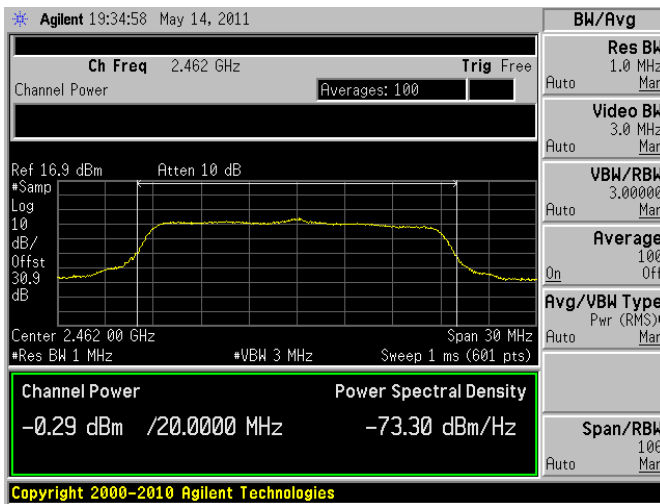

EIRP +30 dBm ~ Low Channel

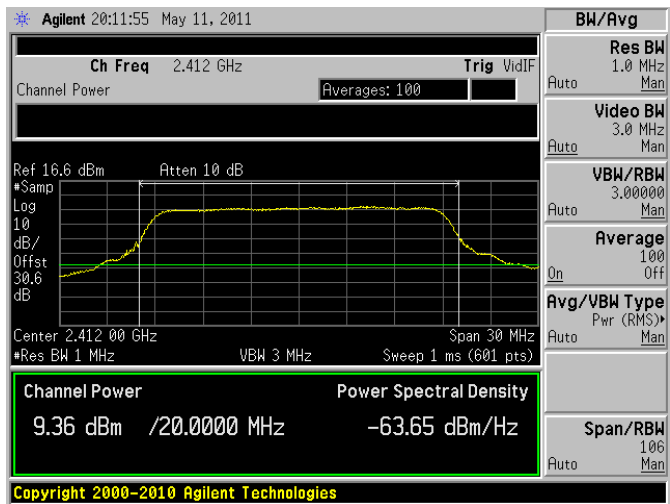

EIRP +30 dBm ~ Middle Channel

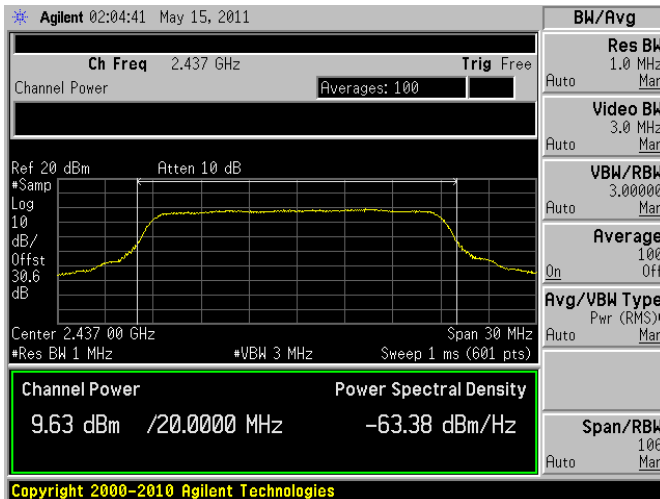

EIRP +30 dBm ~ High Channel

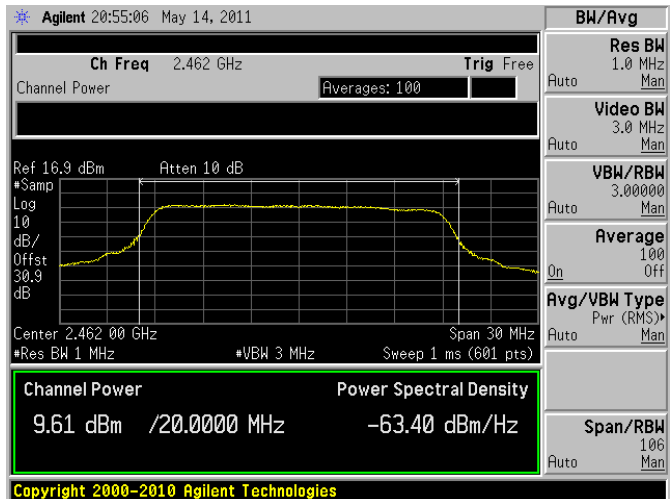

EIRP MIMO +36 dBm ~ Low Channel

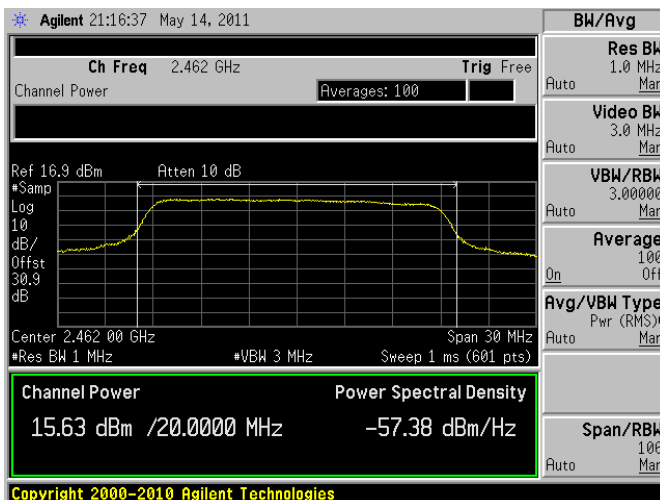

EIRP MIMO +36 dBm ~ Middle Channel

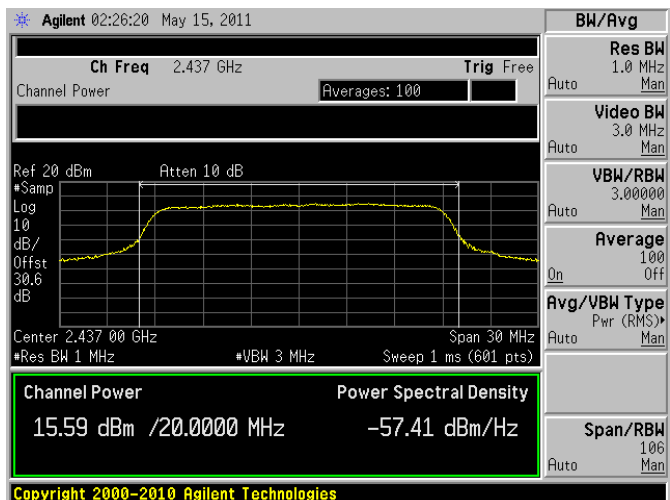



EIRP MIMO +36 dBm ~ High Channel

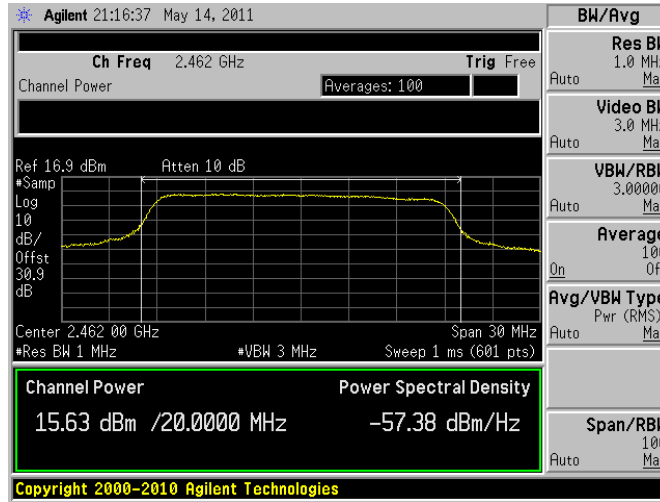

2.4 GHz, Antenna #4:

BPSK with 5 MHz Bandwidth

EIRP +20 dBm ~ Low Channel

EIRP +20 dBm ~ Middle Channel

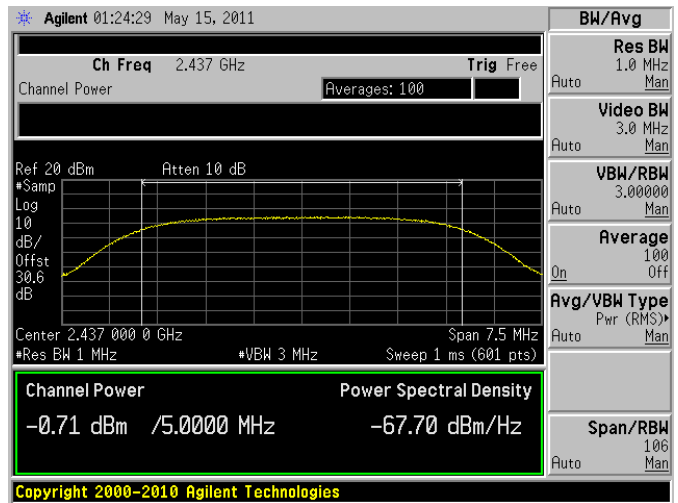
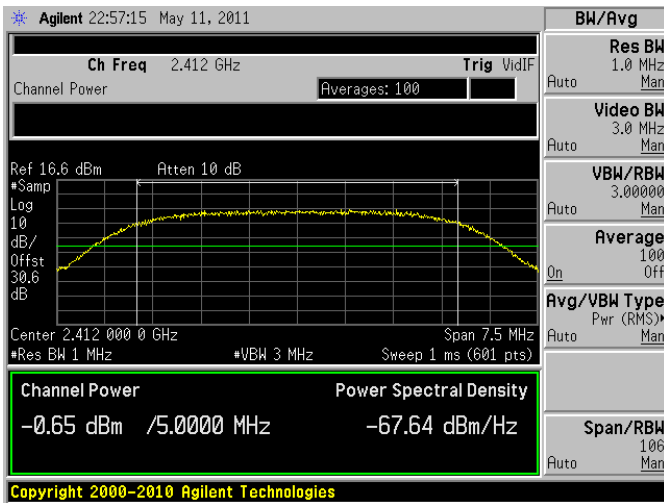

EIRP +20 dBm ~ High Channel

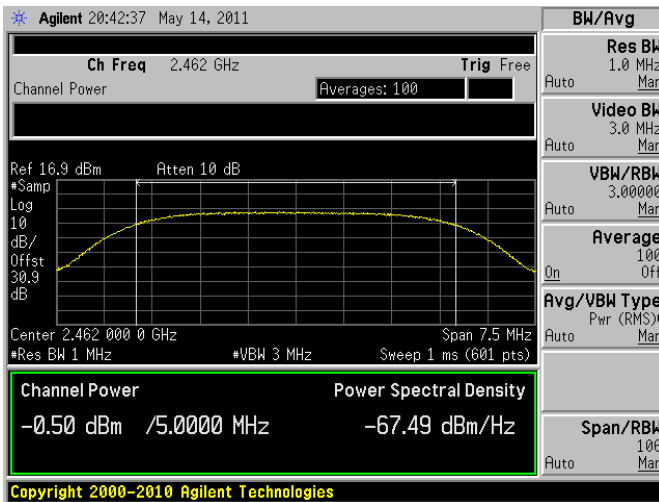

EIRP +30 dBm ~ Low Channel

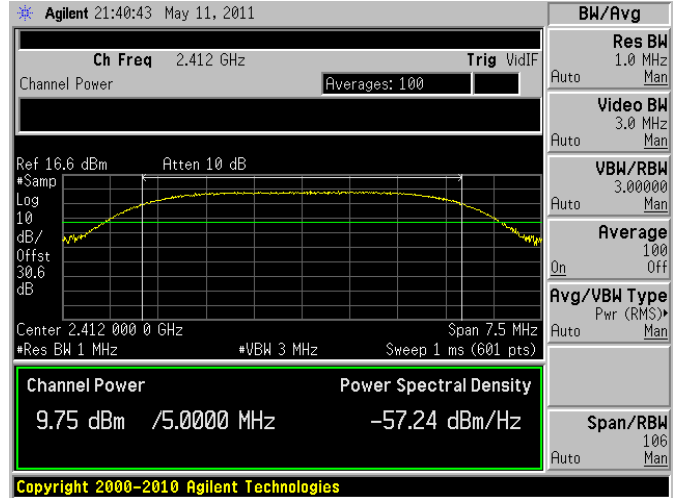

EIRP +30 dBm ~ Middle Channel

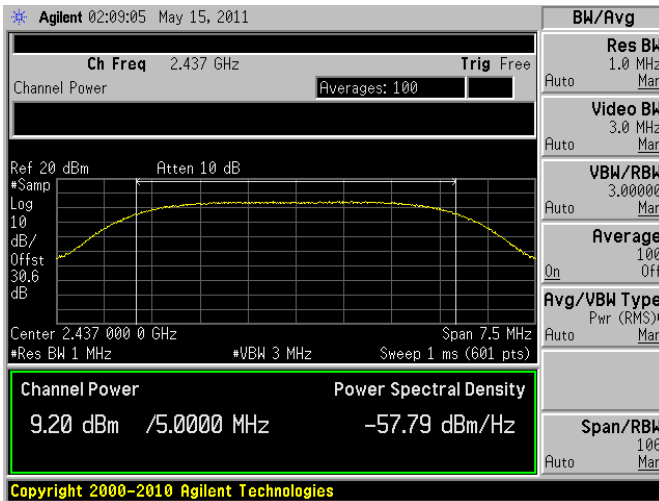

EIRP +30 dBm ~ High Channel

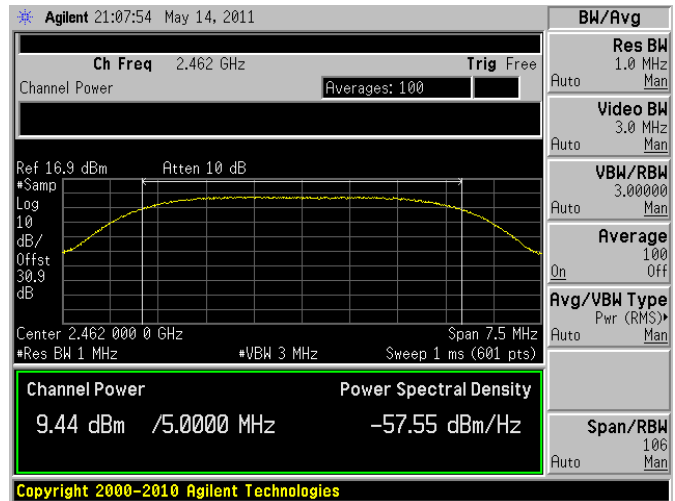

EIRP MIMO +36 dBm ~ Low Channel

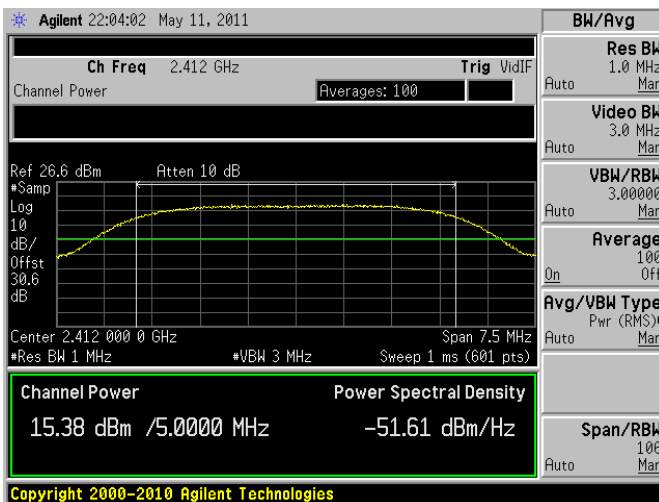

EIRP MIMO +36 dBm ~ Middle Channel

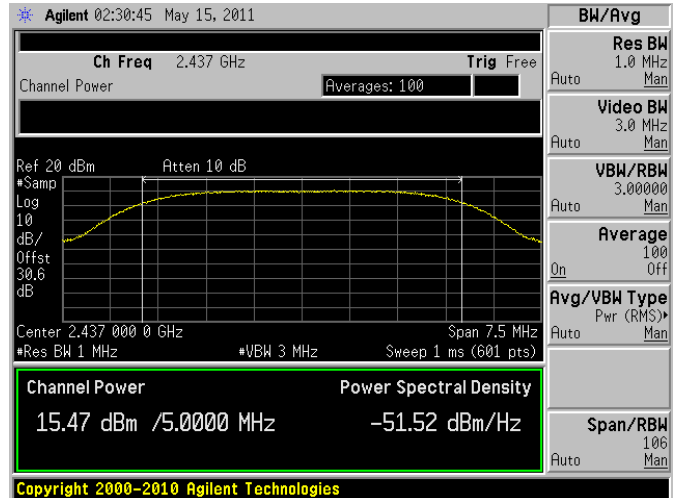

EIRP MIMO +36 dBm ~ High Channel

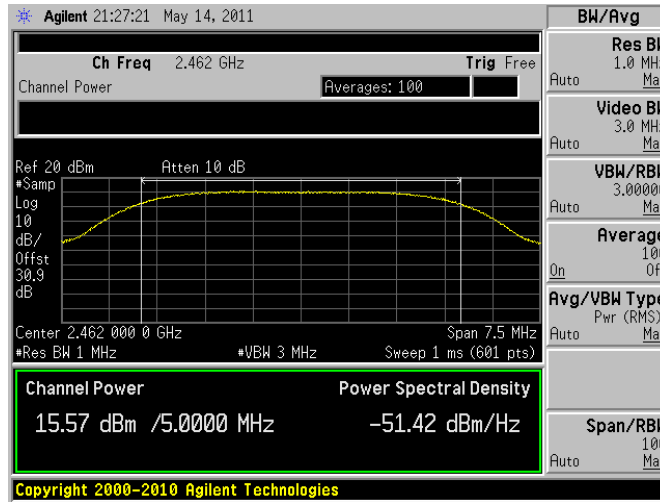

BPSK with 20 MHz Bandwidth

EIRP +20 dBm ~ Low Channel

EIRP +20 dBm ~ Middle Channel

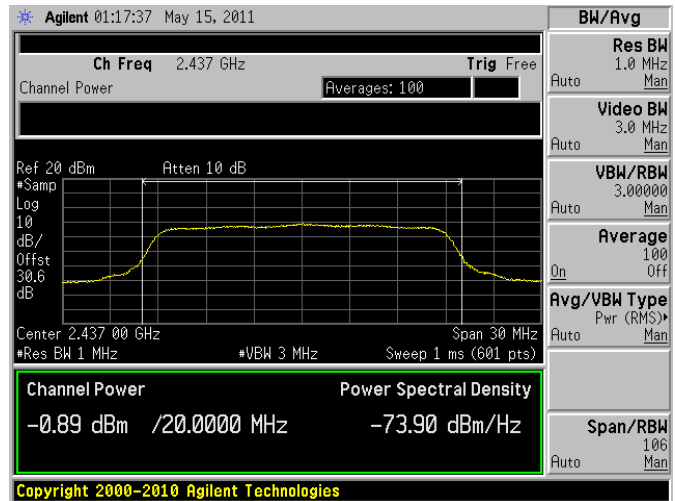
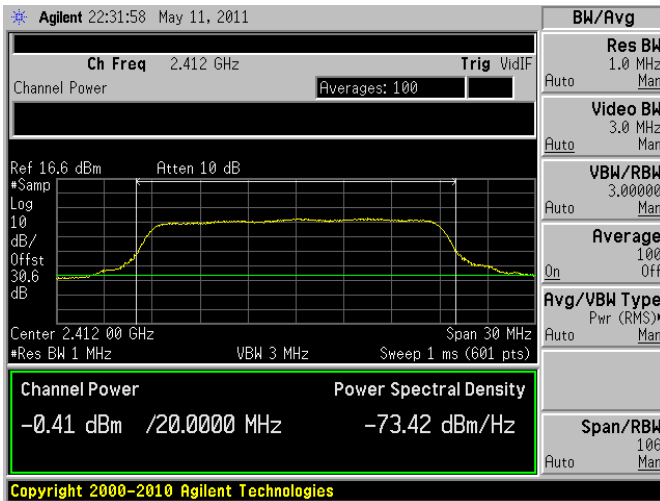

EIRP +20 dBm ~ High Channel

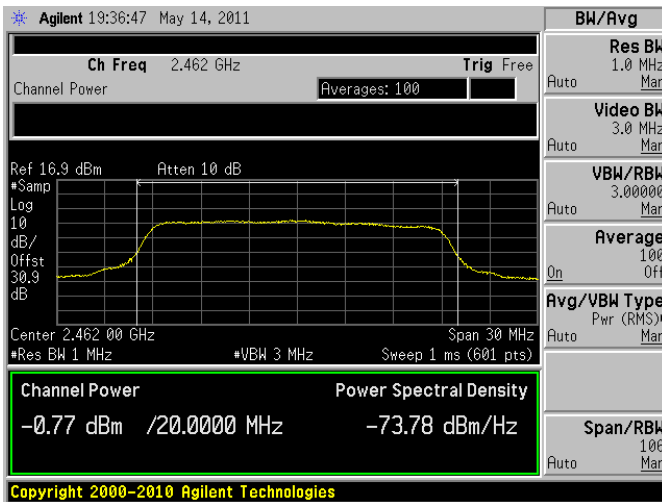

EIRP +30 dBm ~ Low Channel

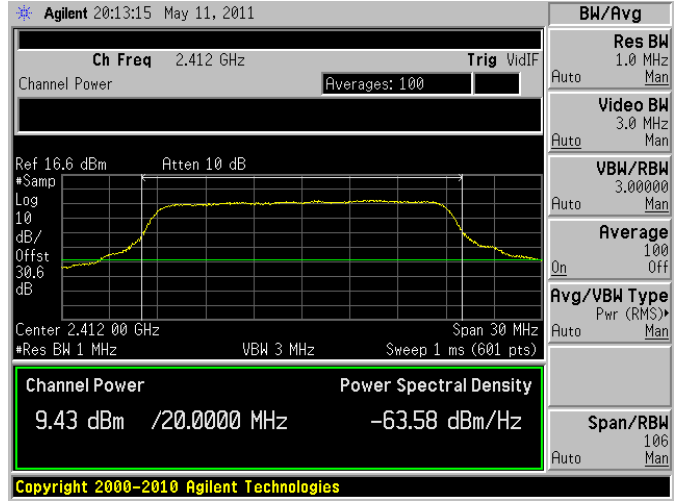

EIRP +30 dBm ~ Middle Channel

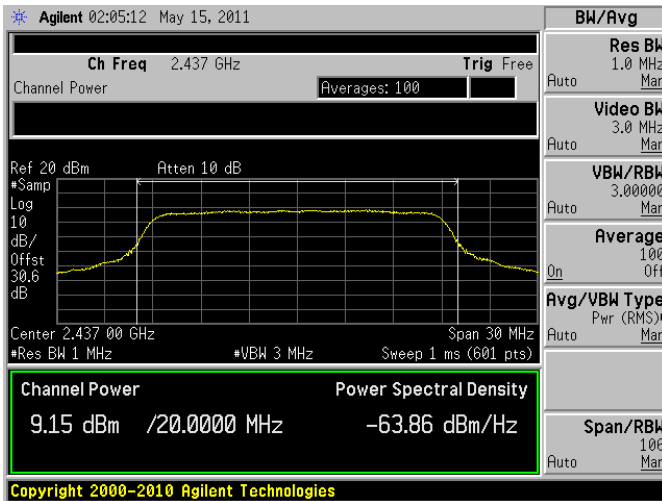

EIRP +30 dBm ~ High Channel

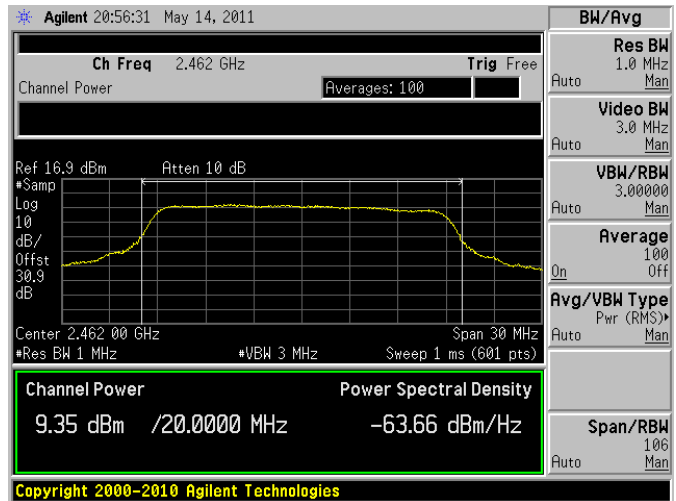

EIRP MIMO +36 dBm ~ Low Channel

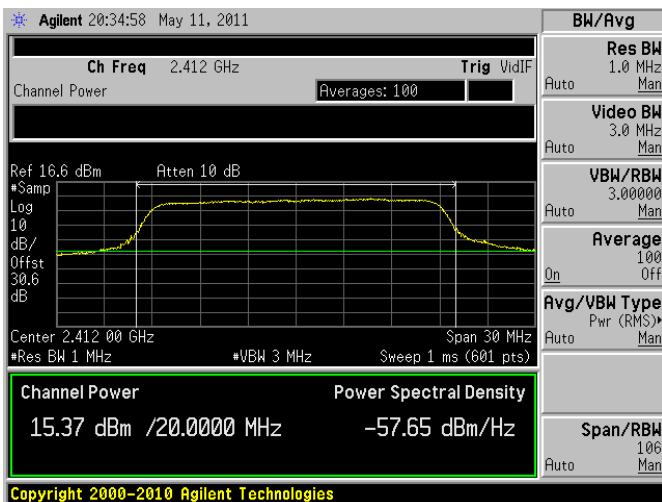

EIRP MIMO +36 dBm ~ Middle Channel

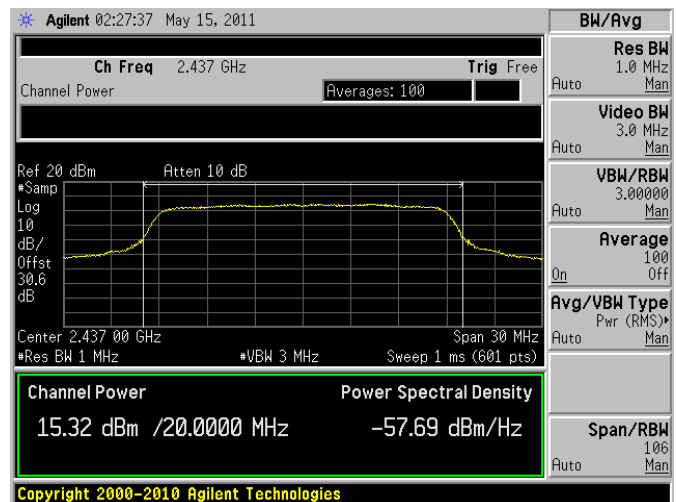

EIRP MIMO +36 dBm ~ High Channel

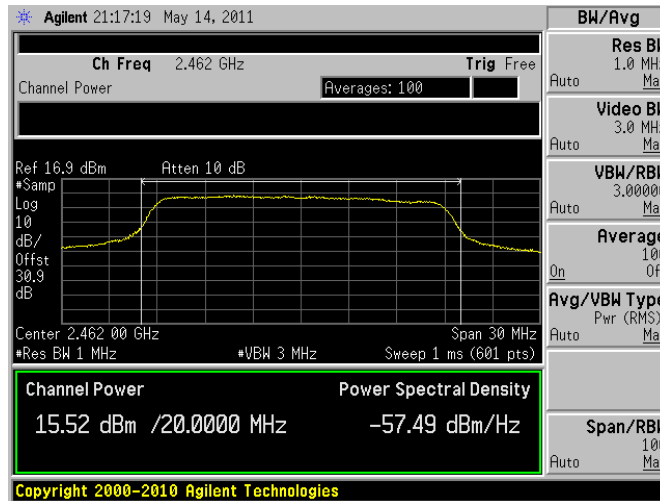

5.8 GHz (5745- 5825 MHz)

5.8 GHz, Antenna #1:

BPSK with 5 MHz Bandwidth

EIRP +30 dBm ~ Low Channel

EIRP +30 dBm ~ Middle Channel

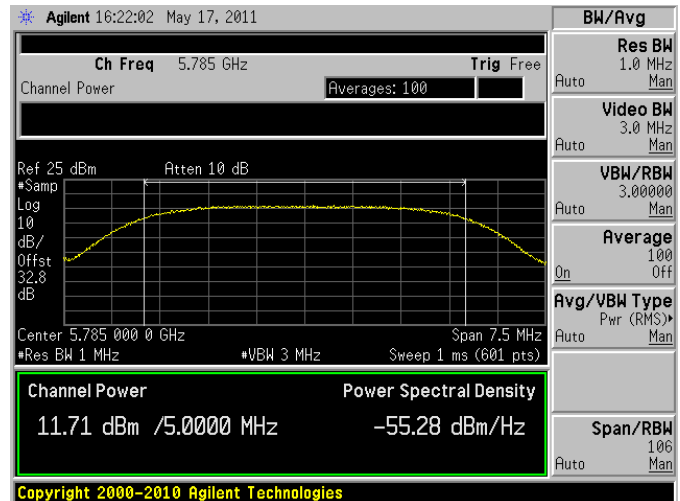
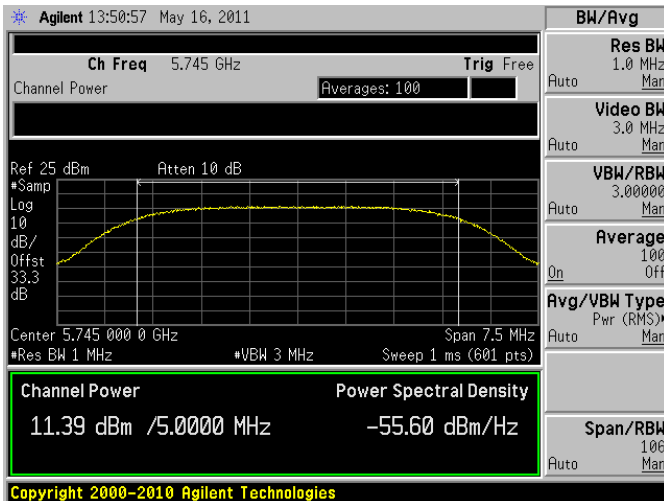

EIRP +30 dBm ~ High Channel

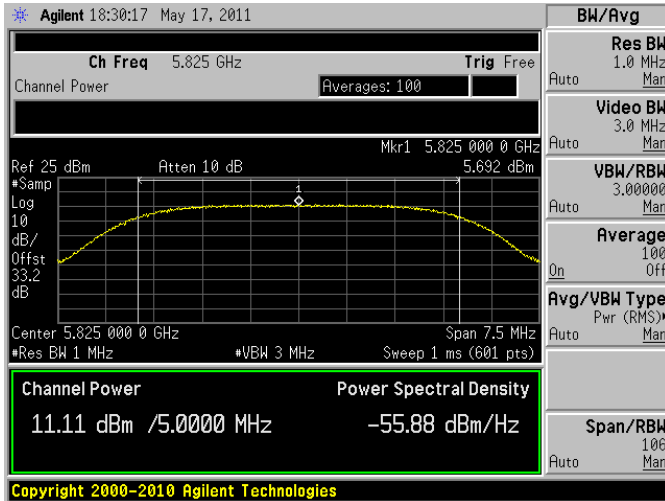

EIRP +36 dBm ~ Low Channel

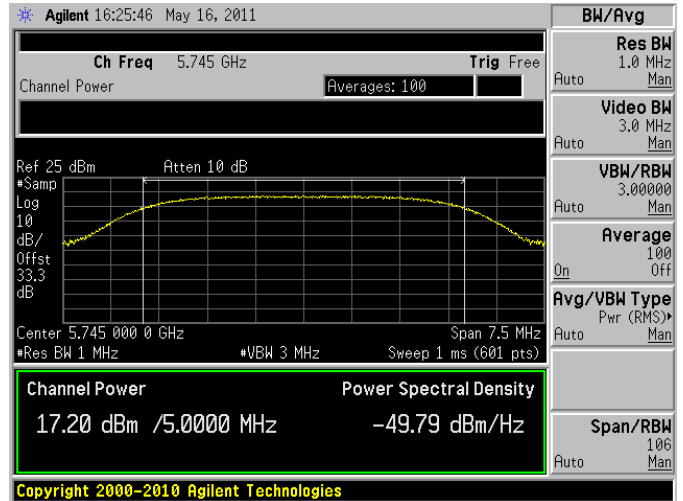

EIRP +36 dBm ~ Middle Channel

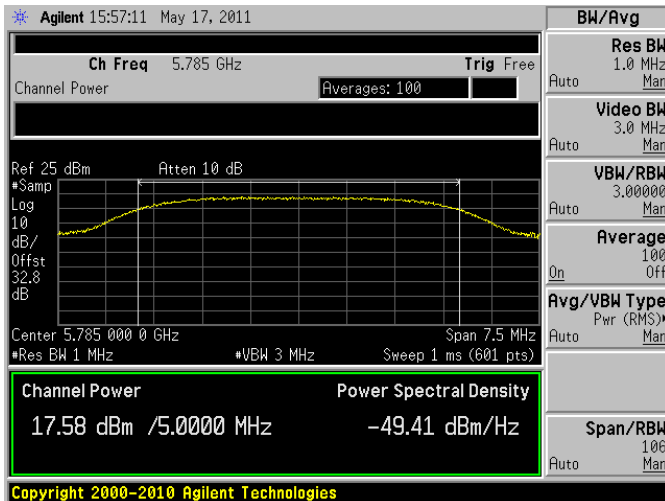

EIRP +36 dBm ~ High Channel

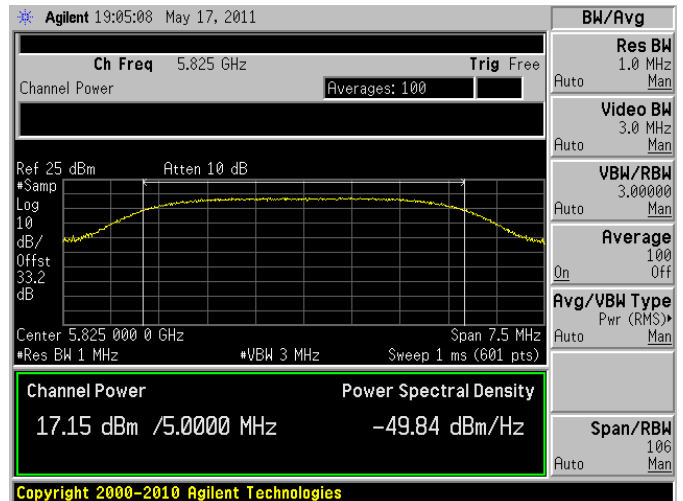

### BPSK with 20 MHz Bandwidth

EIRP +30 dBm ~ Low Channel

EIRP +30 dBm ~ Middle Channel

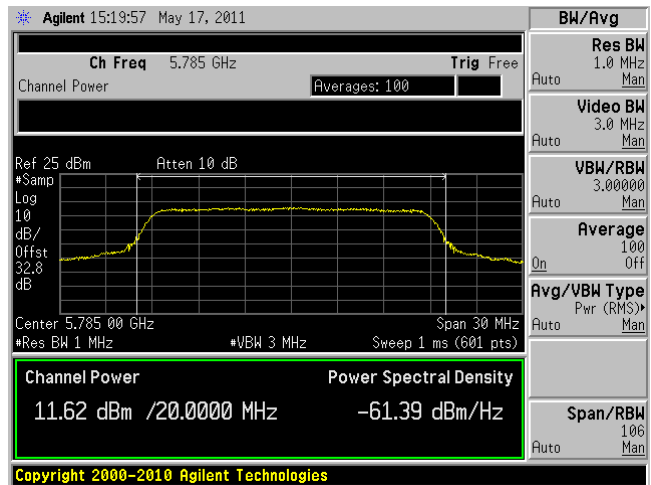
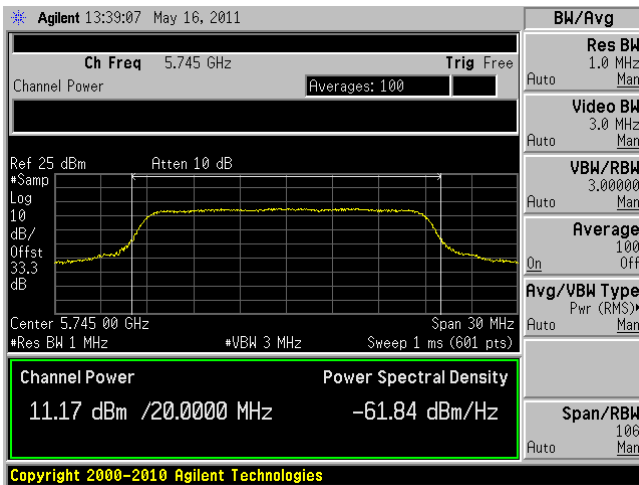

EIRP +30 dBm ~ High Channel

EIRP +36 dBm ~ Low Channel

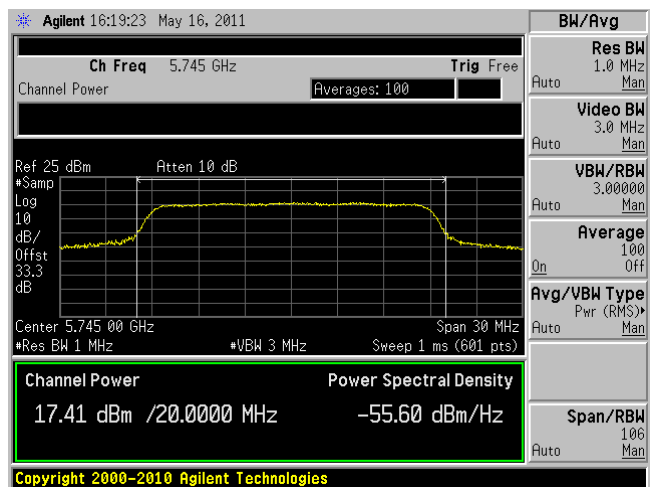
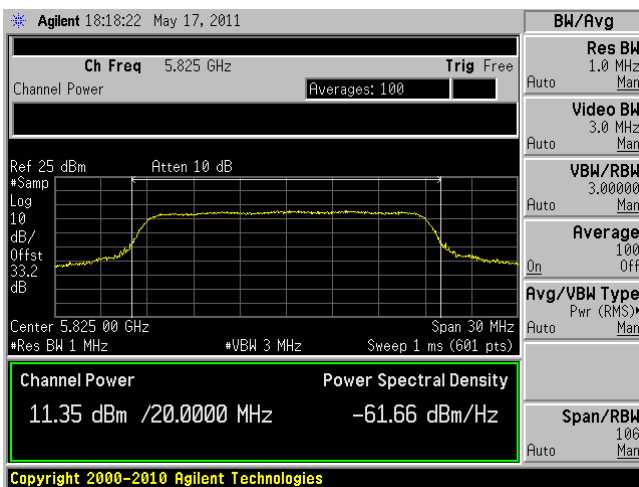

EIRP +36 dBm ~ Middle Channel

EIRP +36 dBm ~ High Channel

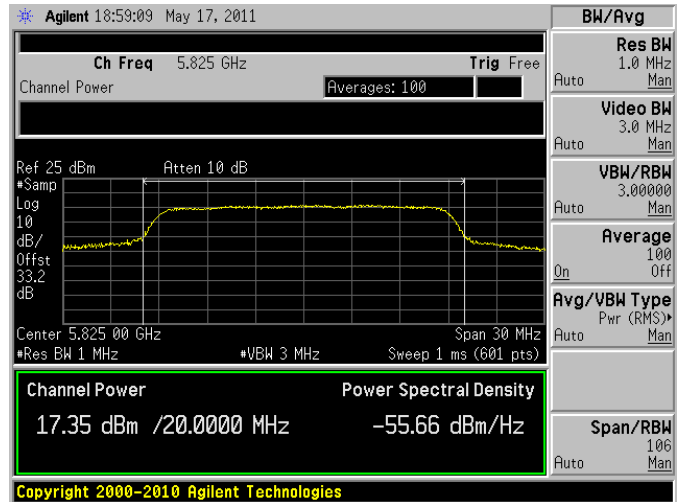
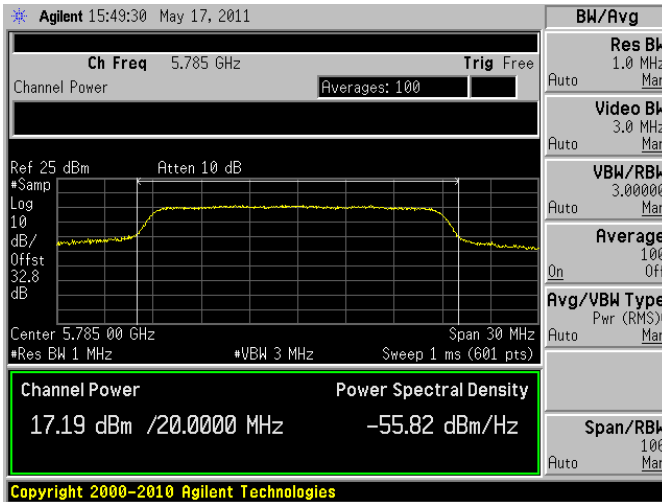

5.8 GHz, Antenna #2:  
BPSK with 5 MHz Bandwidth

EIRP +30 dBm ~ Low Channel

EIRP +30 dBm ~ Middle Channel

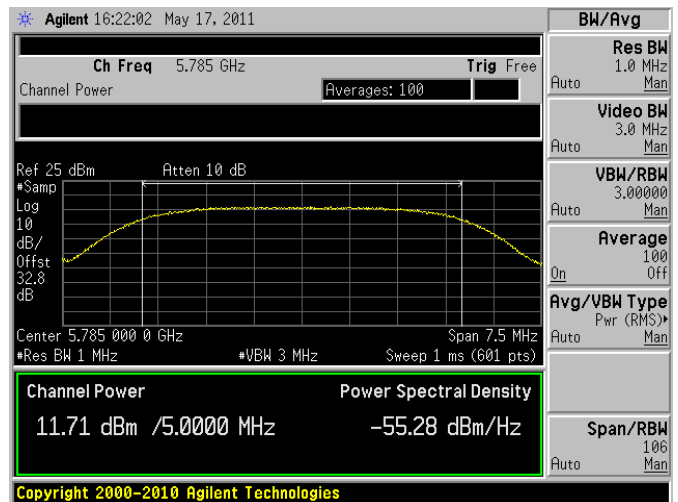
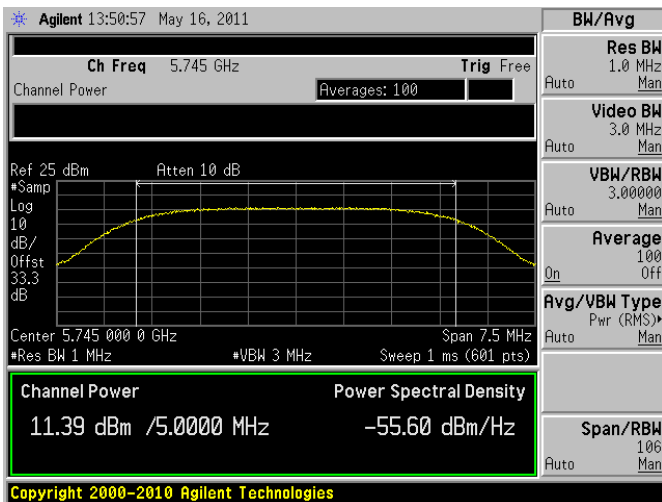



EIRP +30 dBm ~ High Channel

EIRP +36 dBm ~ Low Channel

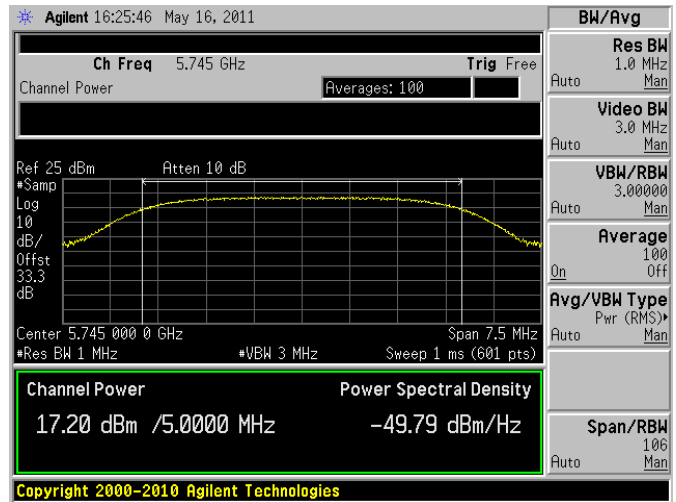
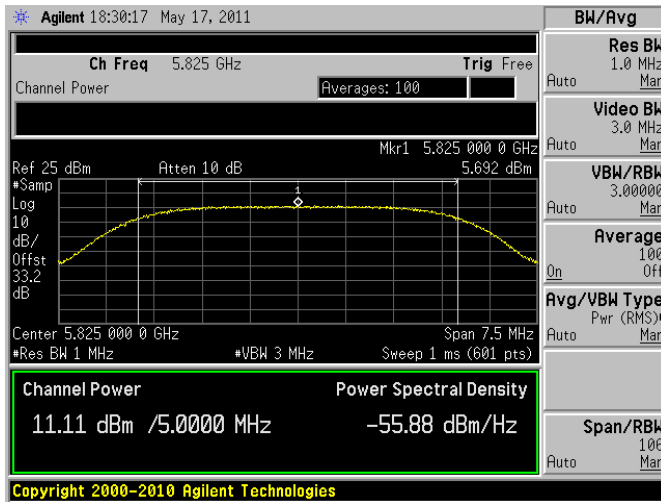

EIRP +36 dBm ~ Middle Channel

EIRP +36 dBm ~ High Channel

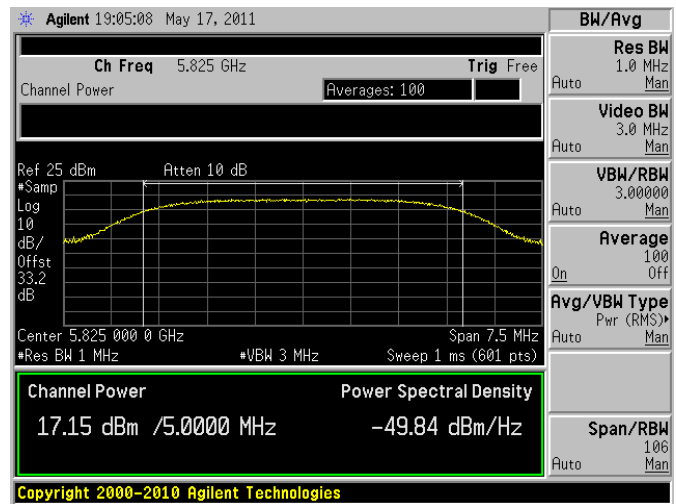
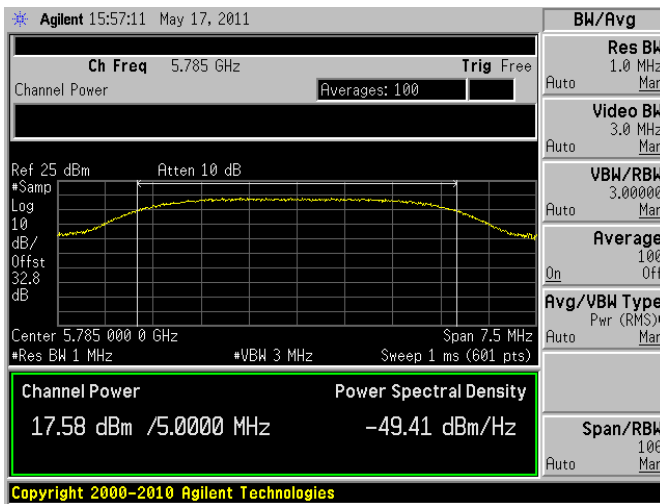

**BPSK with 20 MHz Bandwidth**

EIRP +30 dBm ~ Low Channel

EIRP +30 dBm ~ Middle Channel

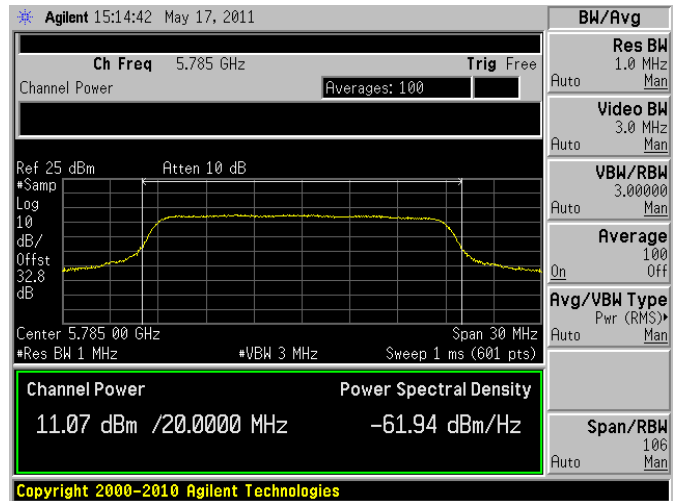
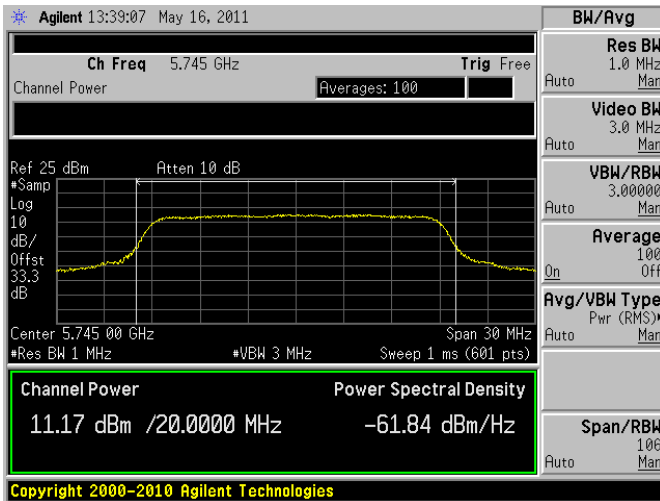

EIRP +30 dBm ~ High Channel

EIRP +36 dBm ~ Low Channel

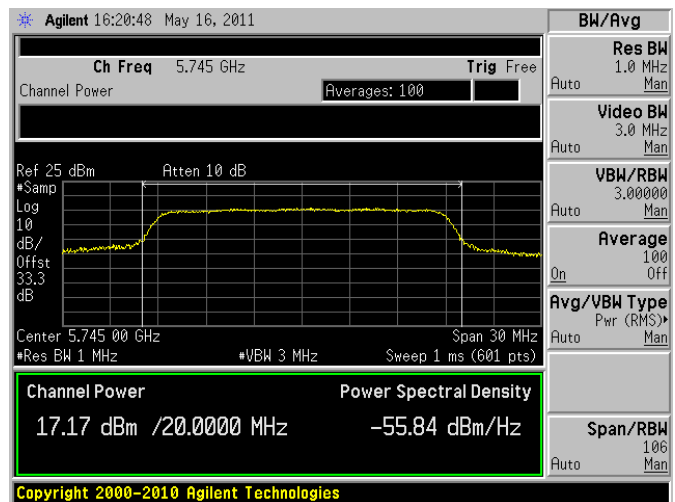
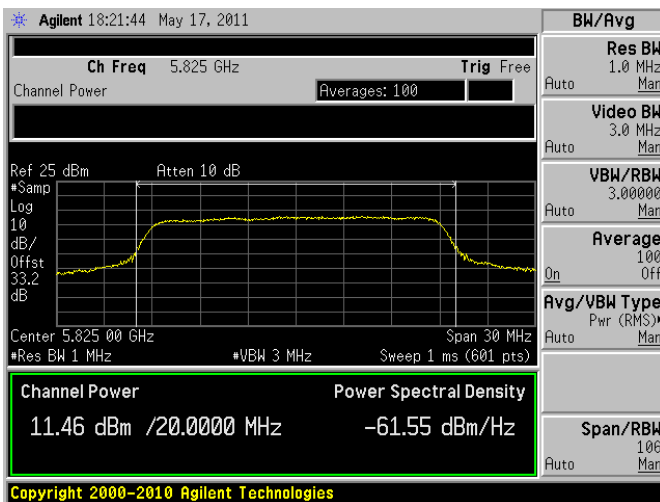

EIRP +36 dBm ~ Middle Channel

EIRP +36 dBm ~ High Channel

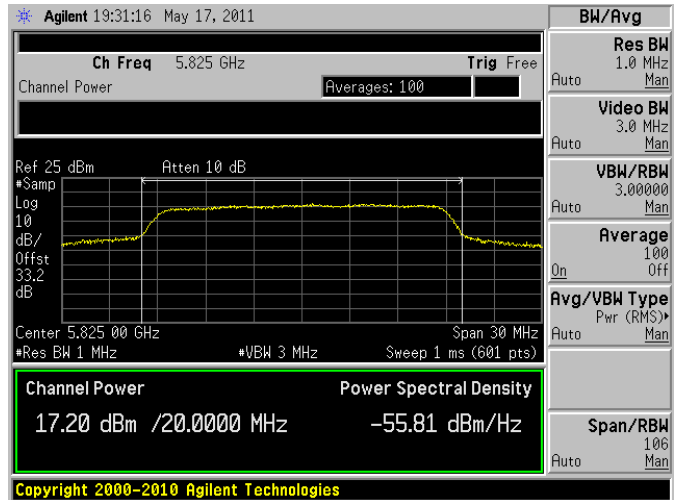
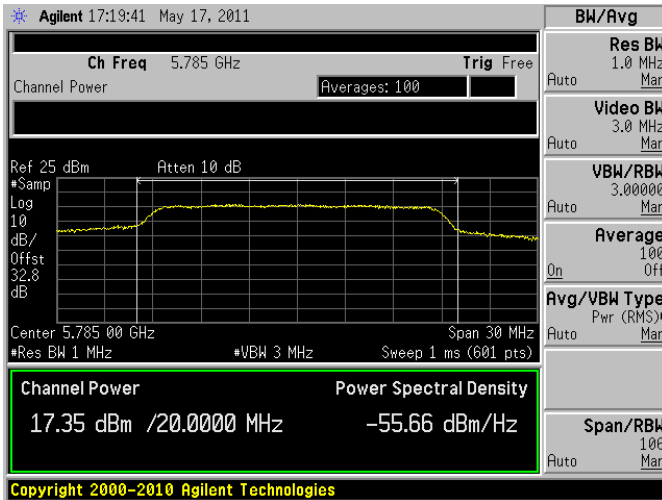

5.8 GHz, Antenna #3:

BPSK with 5 MHz Bandwidth

EIRP +30 dBm ~ Low Channel

EIRP +30 dBm ~ Middle Channel

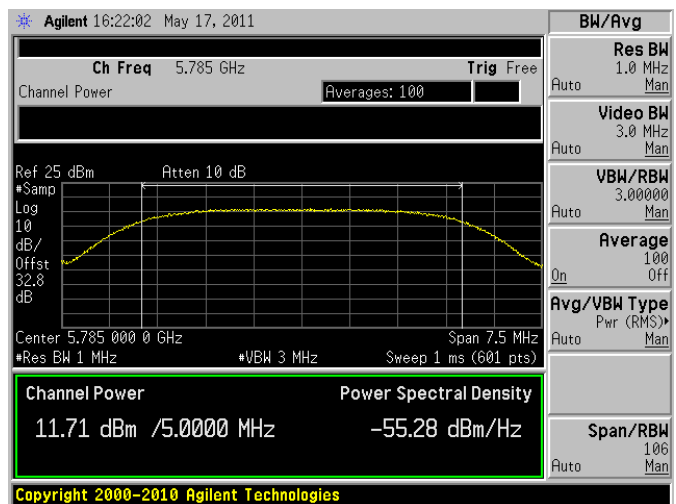
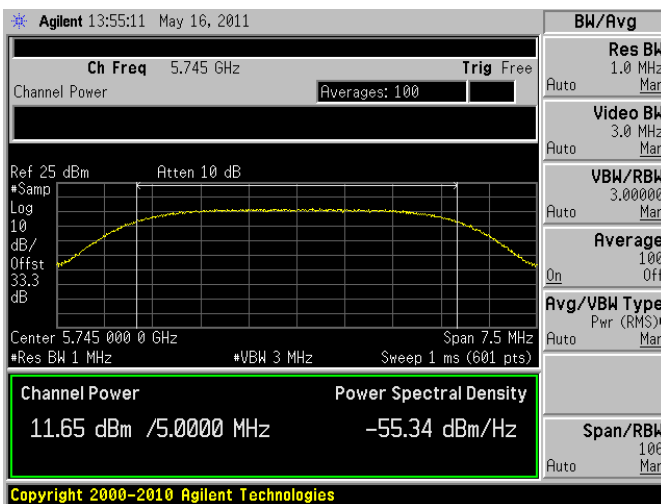

EIRP +30 dBm ~ High Channel

EIRP +36 dBm ~ Low Channel

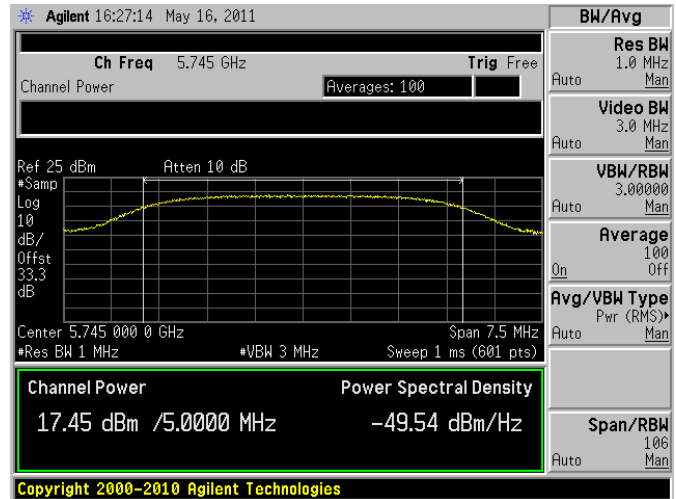
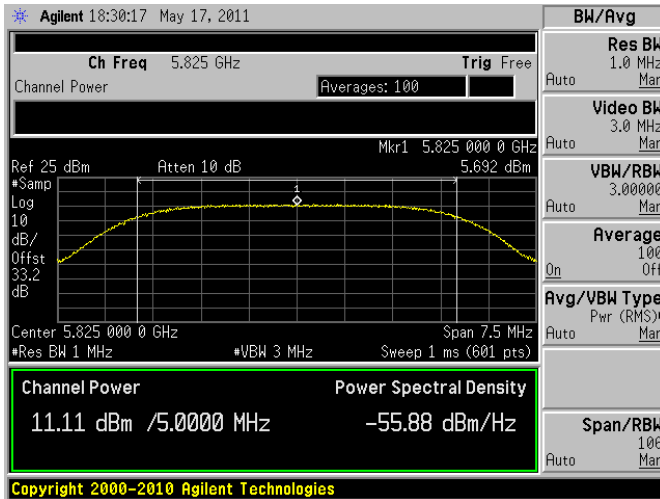

EIRP +36dBm ~ Middle Channel

EIRP +36dBm ~ High Channel

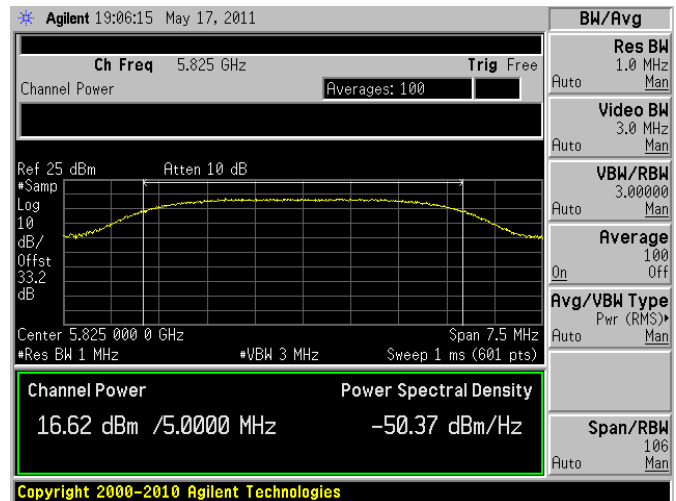
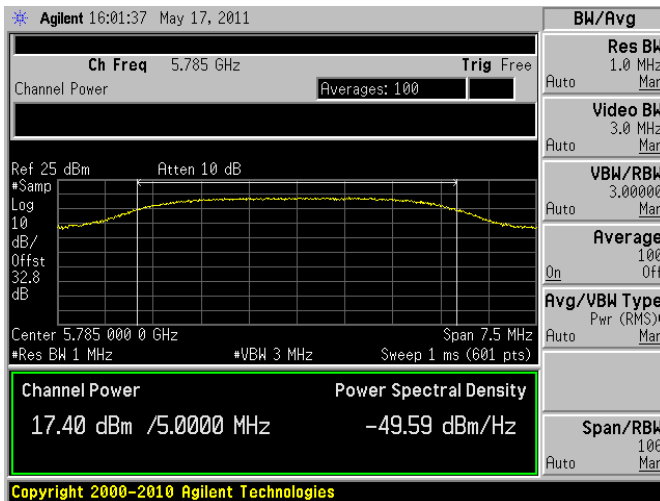

### BPSK with 20 MHz Bandwidth

EIRP +30 dBm ~ Low Channel

EIRP +30 dBm ~ Middle Channel

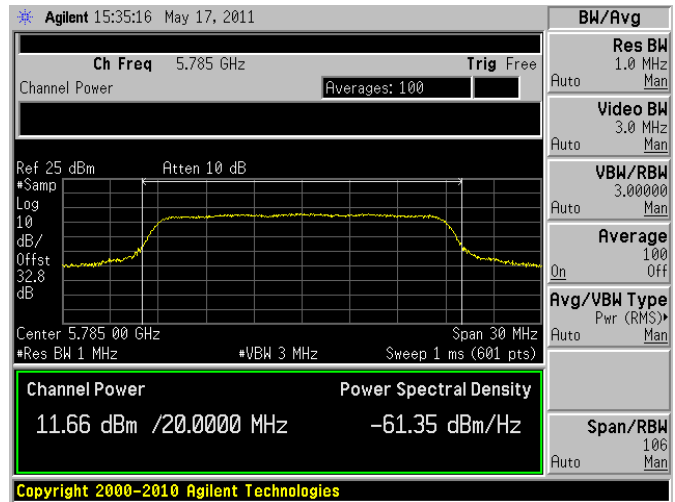
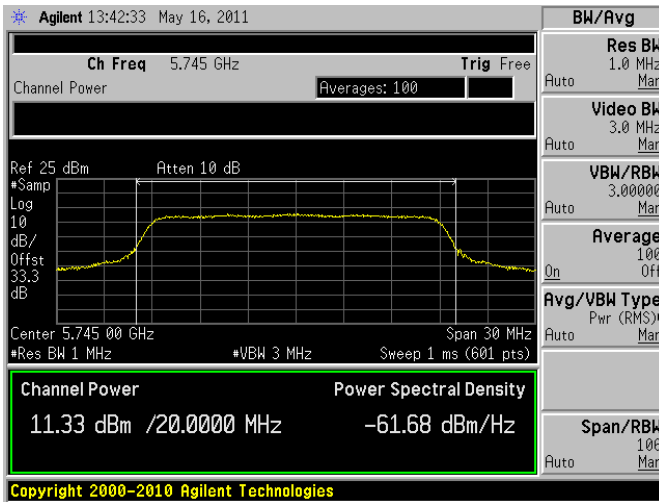

EIRP +30 dBm ~ High Channel

EIRP +36 dBm ~ Low Channel

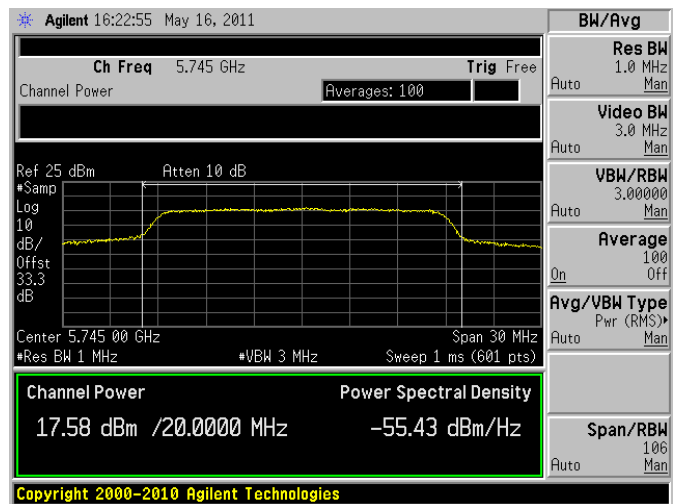
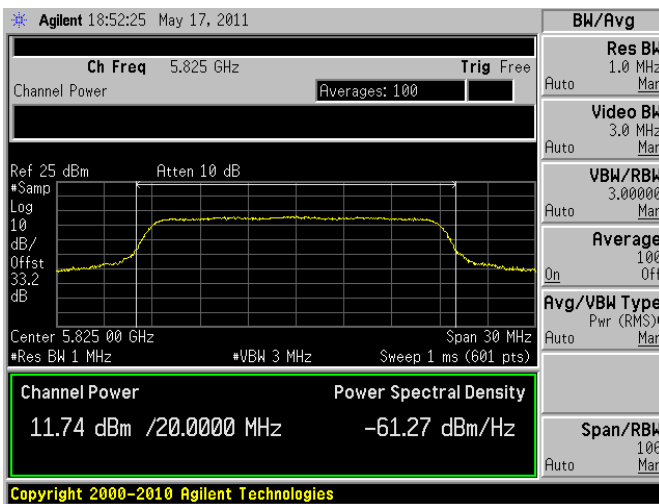

EIRP +36 dBm ~ Middle Channel

EIRP +36 dBm ~ High Channel

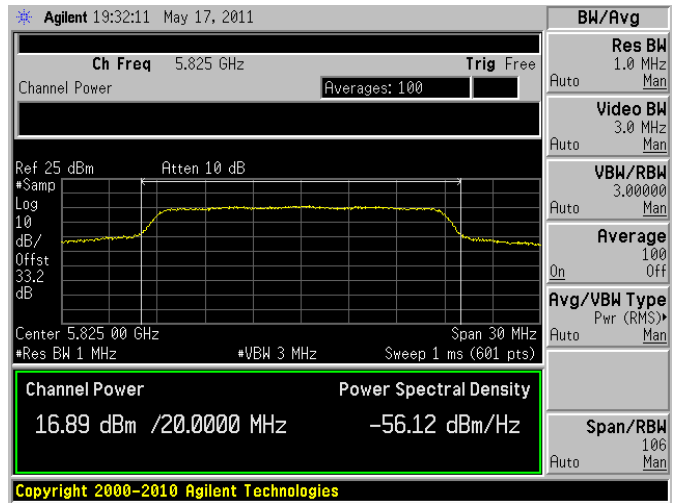
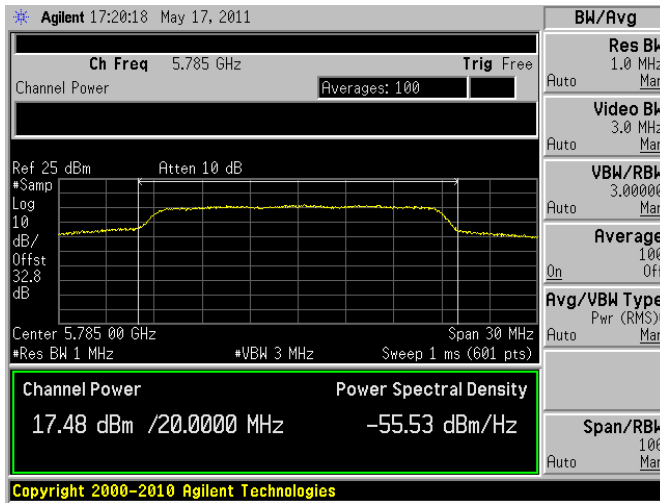

5.8 GHz, Antenna #4:

BPSK with 5 MHz Bandwidth

EIRP +30 dBm ~ Low Channel

EIRP +30 dBm ~ Middle Channel

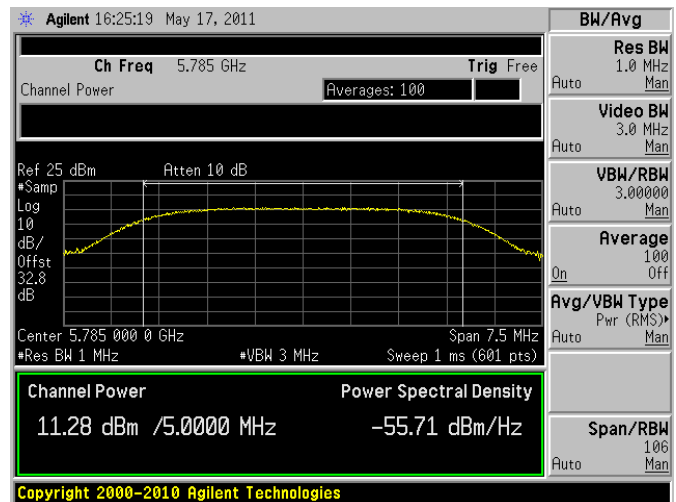
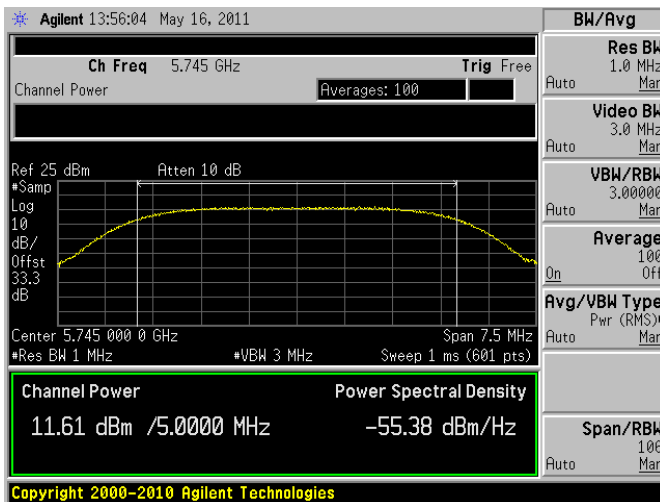

EIRP +30 dBm ~ High Channel

EIRP +36 dBm ~ Low Channel

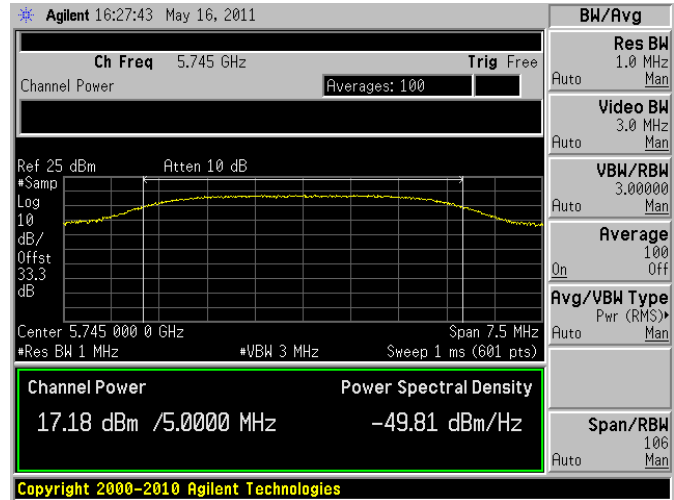
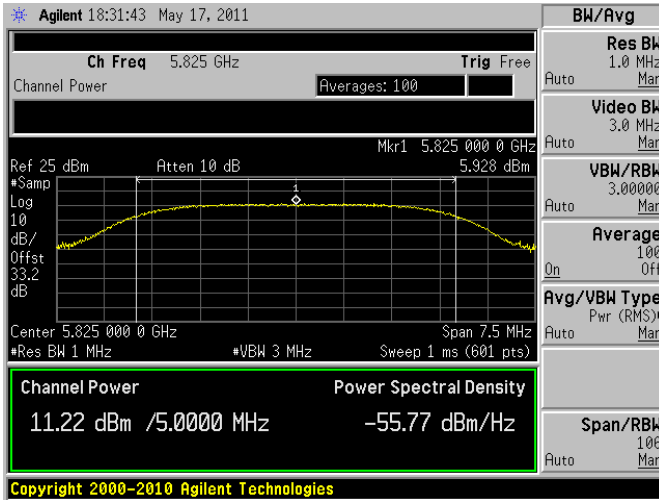

EIRP +36 dBm ~ Middle Channel

EIRP +36 dBm ~ High Channel

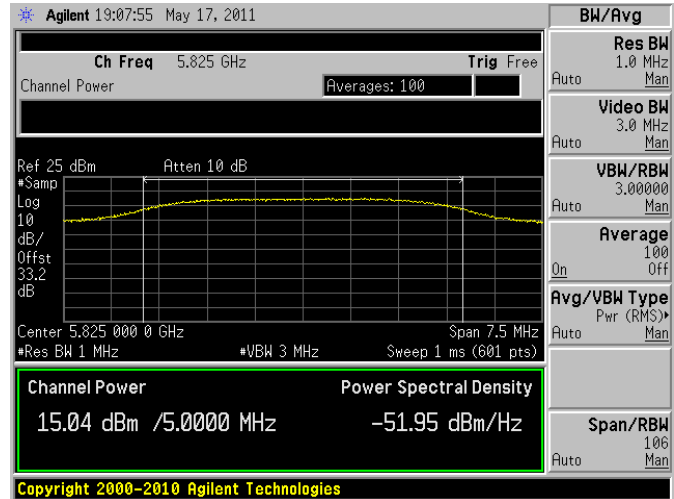
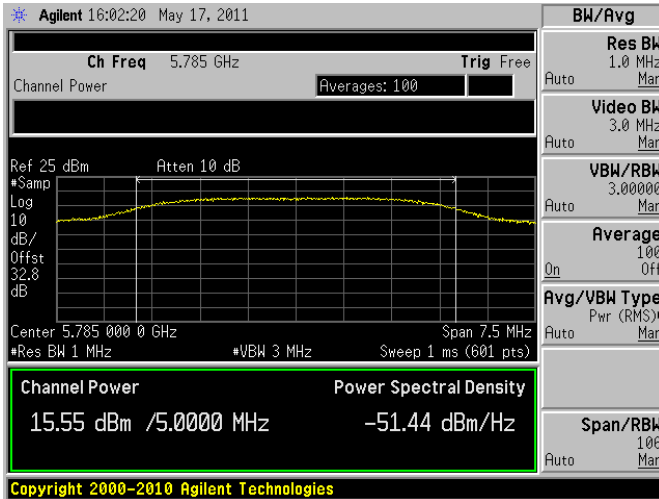

### BPSK with 20 MHz Bandwidth

EIRP +30 dBm ~ Low Channel

EIRP +30 dBm ~ Middle Channel

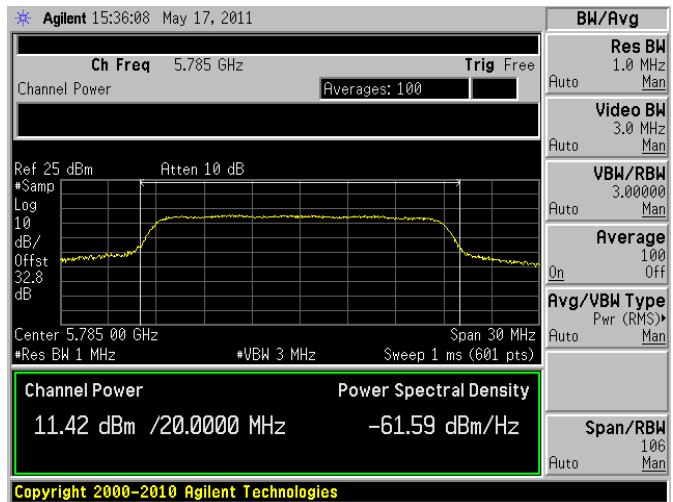
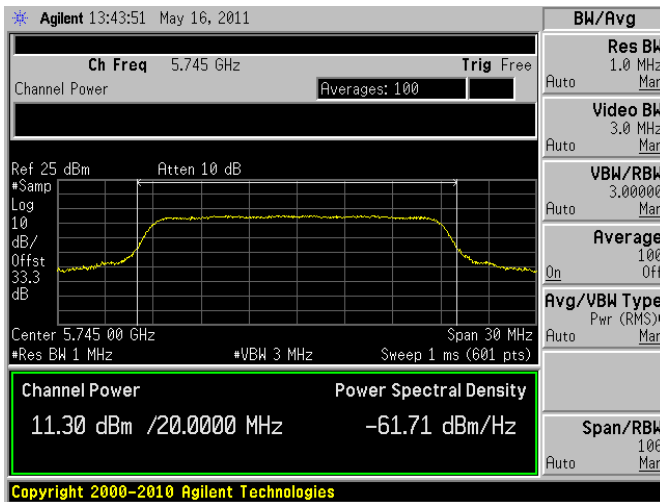

EIRP +30 dBm ~ High Channel

EIRP +36 dBm ~ Low Channel

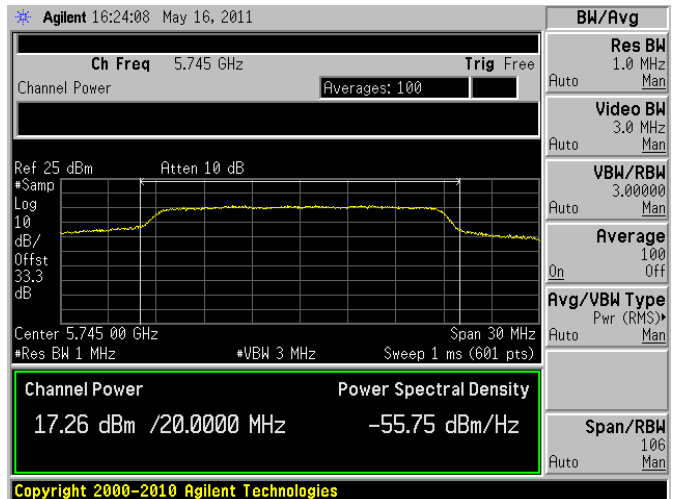
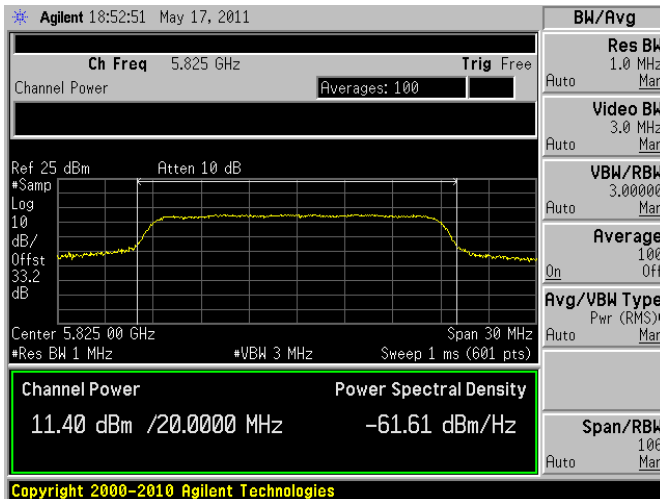



EIRP +36 dBm ~ Middle Channel

EIRP +36 dBm ~ High Channel

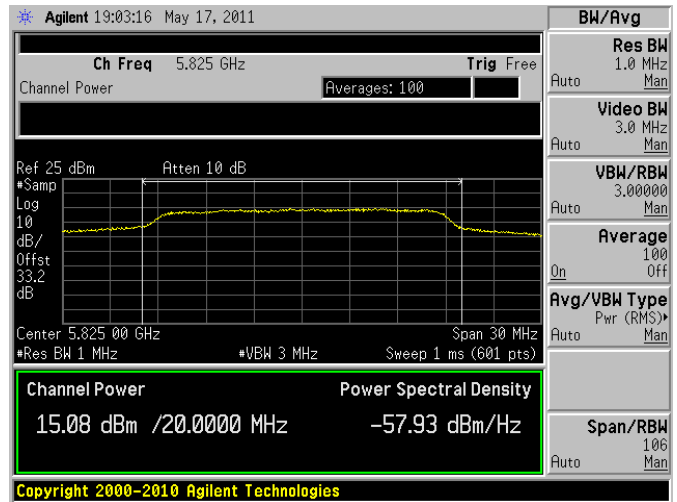
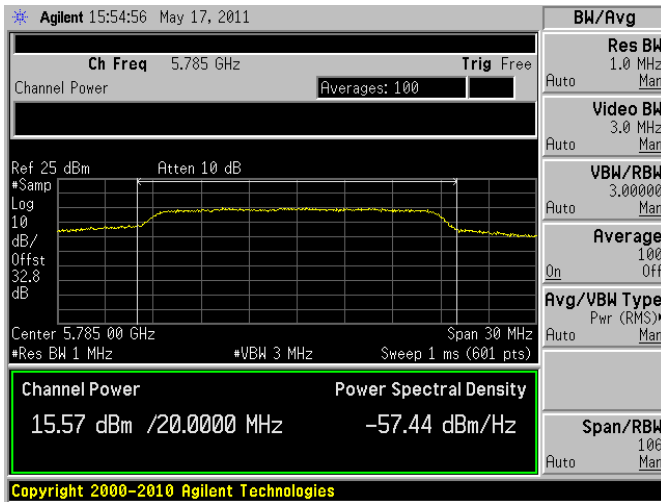

## 11 FCC §15.247(d) & IC RSS-210 §A8.5 - 100 kHz Bandwidth of Band Edges

### 11.1 Applicable Standard

According to FCC §15.247(d), in any 100 kHz bandwidth outside the frequency bands in which the spread spectrum intentional radiator is operating, the radio frequency power that is produced by the intentional radiator shall be at least 20 dB below that in the 100 kHz bandwidth within the band that contains the highest level of the desired power, based on either an RF conducted or a radiated measurement. In addition, radiated emissions which fall in the restricted bands, as defined in §15.205(a), must also comply with the radiated emissions limits specified in §15.209(a) see §15.205(c).

According to IC RSS-210 §A8.5, in any 100 kHz bandwidth outside the frequency band in which the spread spectrum or digitally modulated device is operating, the radio frequency power that is produced shall be at least 20 dB below that in the 100 kHz bandwidth within the band that contains the highest level of the desired power, based on either an RF conducted or a radiated measurement, provided the transmitter demonstrates compliance with the peak conducted power limits. If the transmitter complies with the conducted power limits based on the use of RMS averaging over a time interval, as permitted under section A8.4(4), the attenuation required shall be 30 dB instead of 20 dB. Attenuation below the general limits specified in Tables 2 and 3 is not required.

### 11.2 Measurement Procedure

1. Check the calibration of the measuring instrument using either an internal calibrator or a known signal from an external generator.
2. Position the EUT without connection to measurement instrument. Turn on the EUT and connect its antenna terminal to measurement instrument via a low loss cable. Then set it to any one measured frequency within its operating range, and make sure the instrument is operated in its linear range.
3. Set both RBW and VBW of spectrum analyzer to 100 kHz with a convenient frequency span including 100 kHz bandwidth from band edge.
4. Measure the highest amplitude appearing on spectral display and set it as a reference level. Plot the graph with marking the highest point and edge frequency.
5. Repeat above procedures until all measured frequencies were complete.

### 11.3 Test Setup Block Diagram

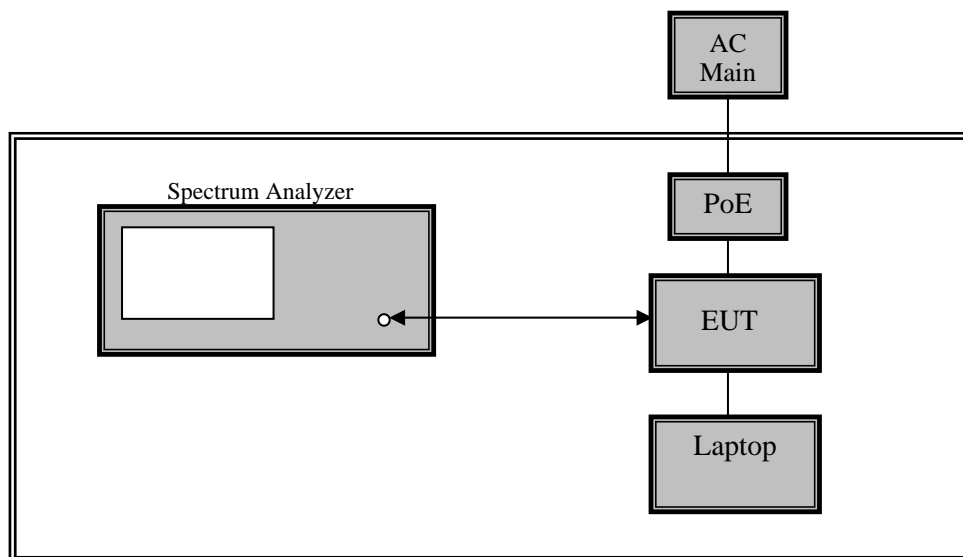

### 11.4 Test Equipment List and Details

Manufacturers	Description	Models	Serial Numbers	Calibration Dates
Agilent	Spectrum Analyzer	E4445A	MY44020562	2011-04-05

**Statement of Traceability:** BACL Corp. attests that all calibrations have been performed per the NVLAP requirements, traceable to the NIST.

### 11.5 Test Environmental Conditions

<b>Temperature:</b>	16.5~27°C
<b>Relative Humidity:</b>	30.9~43.3 %
<b>ATM Pressure:</b>	101-103 kPa

The testing was performed by Brian Fox on 2011-05-13 ~ 2011-05-20.

Please refer to the following plots for detailed results

### 2.4 GHz (2412– 2462 MHz) Band

2.4 GHz, Antenna #1:

BPSK with 5 MHz Bandwidth

EIRP +20 dBm ~ Low Band Edge

EIRP +20 dBm ~ High Band Edge

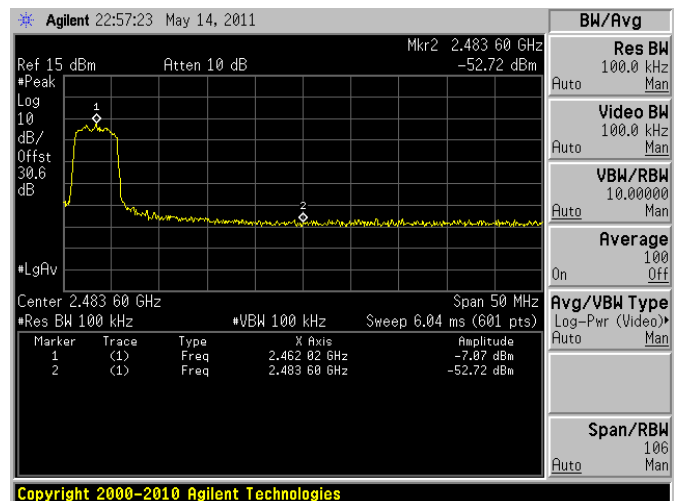
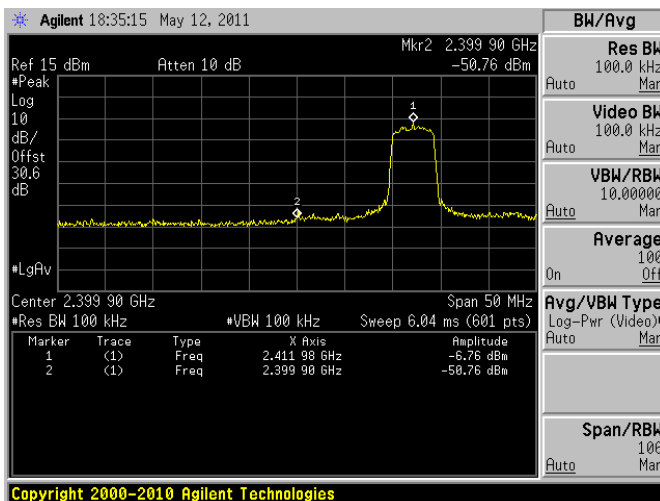

EIRP +30 dBm ~ Low Band Edge

EIRP +30 dBm ~ High Band Edge

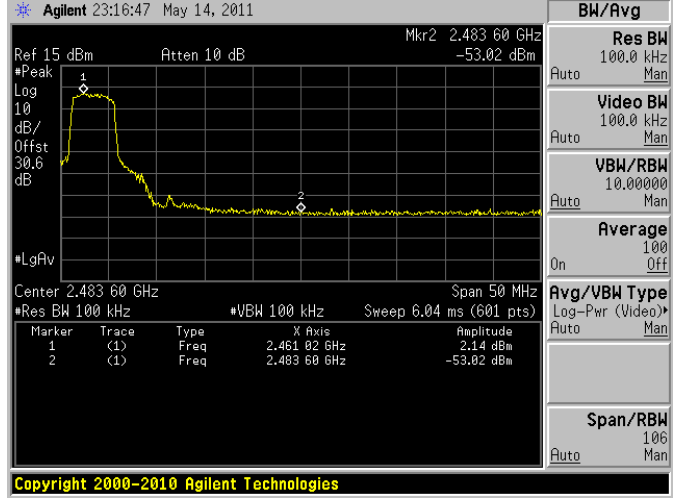
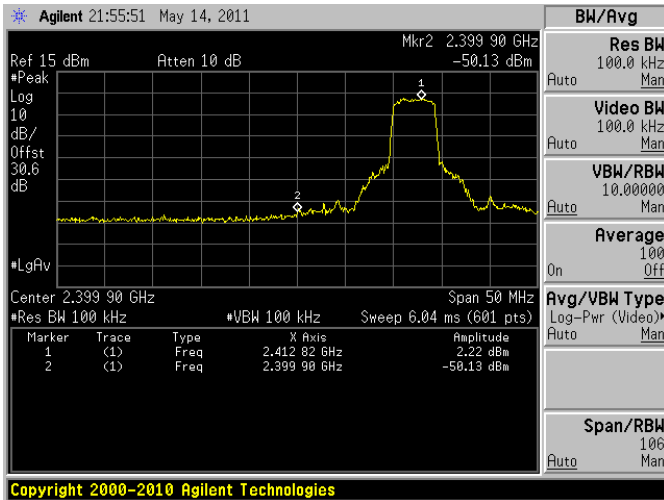

EIRP MIMO +36 dBm ~ Low Band Edge

EIRP MIMO +36 dBm ~ High Band Edge

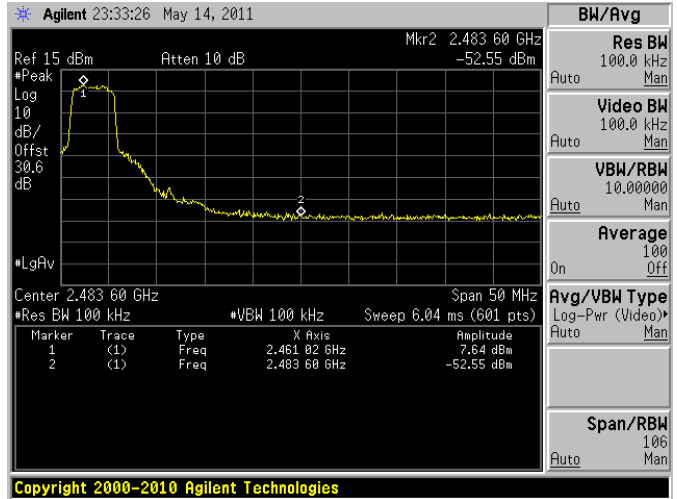
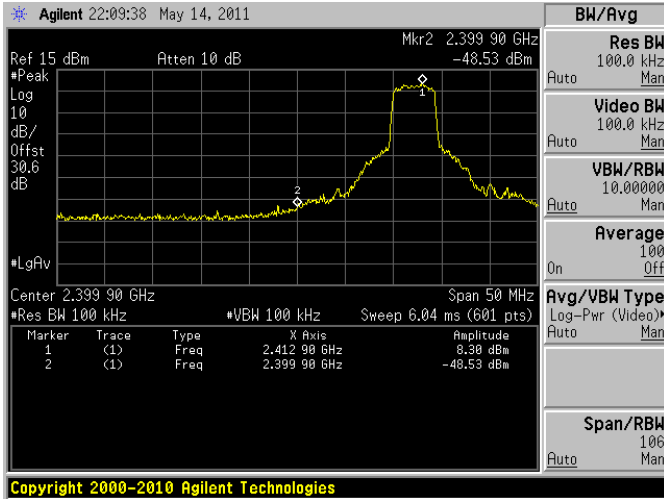

BPSK with 20 MHz Bandwidth

EIRP +20 dBm ~ Low Band Edge

EIRP +20 dBm ~ High Band Edge

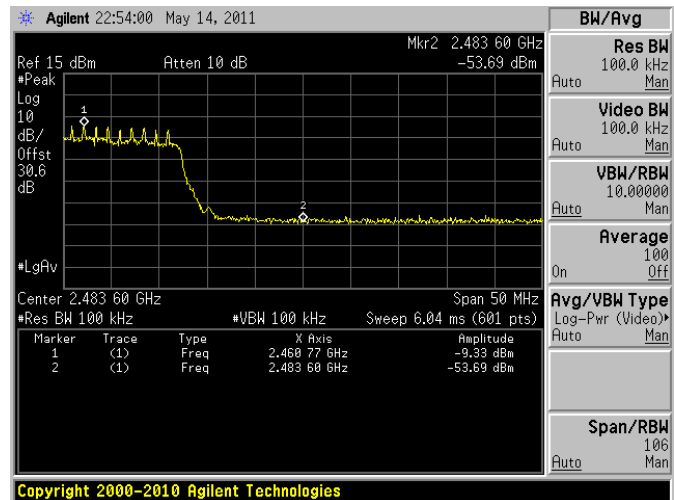
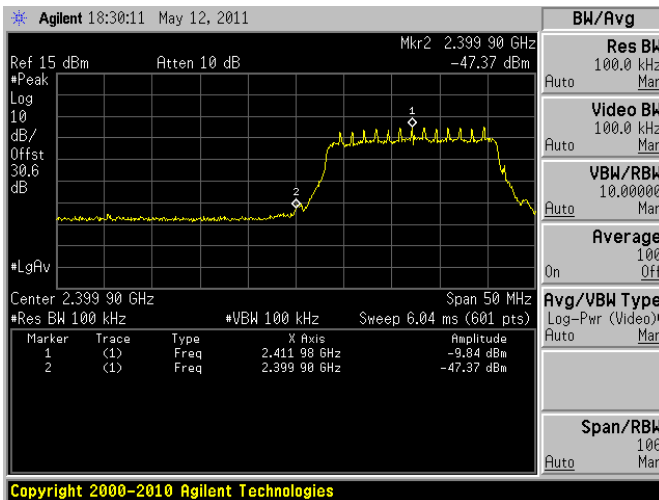

EIRP +30 dBm ~ Low Band Edge

EIRP +30 dBm ~ High Band Edge

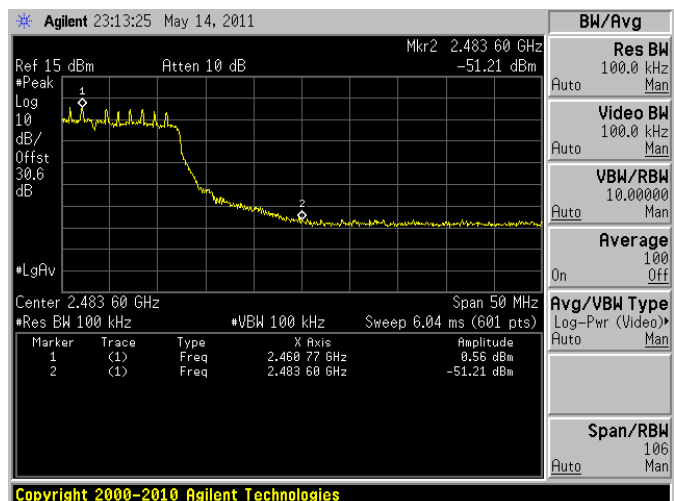
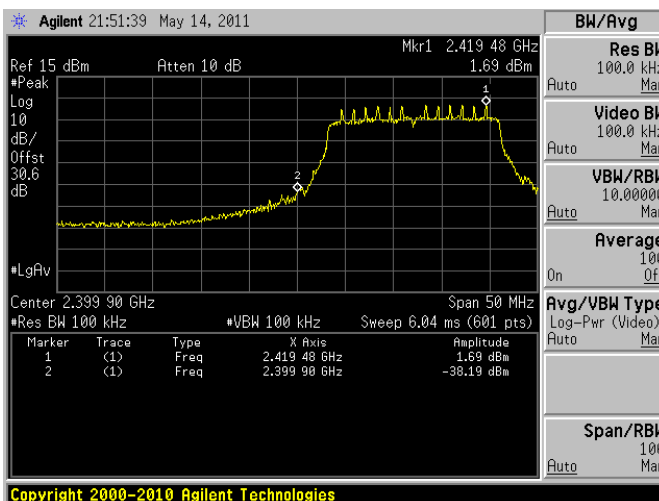

EIRP MIMO +36 dBm ~ Low Band Edge

EIRP MIMO +36 dBm ~ High Band Edge

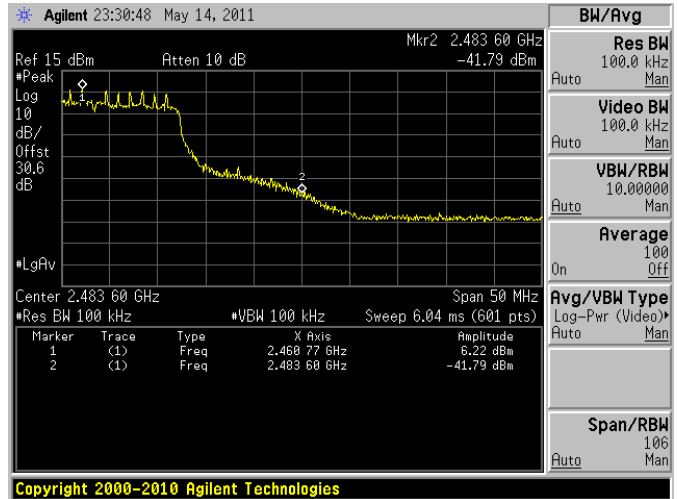
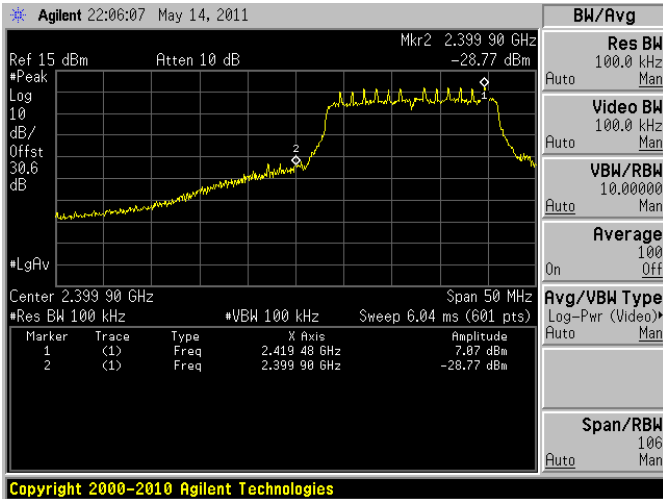

2.4 GHz, Antenna #2:

BPSK with 5 MHz Bandwidth

EIRP +20 dBm ~ Low Band Edge

EIRP +20 dBm ~ High Band Edge

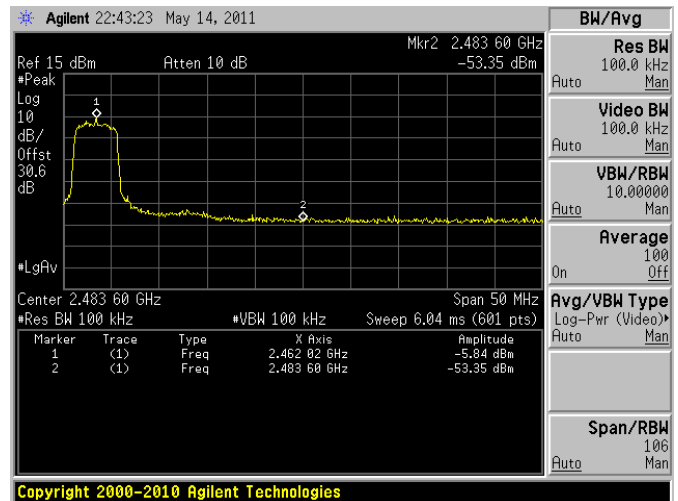
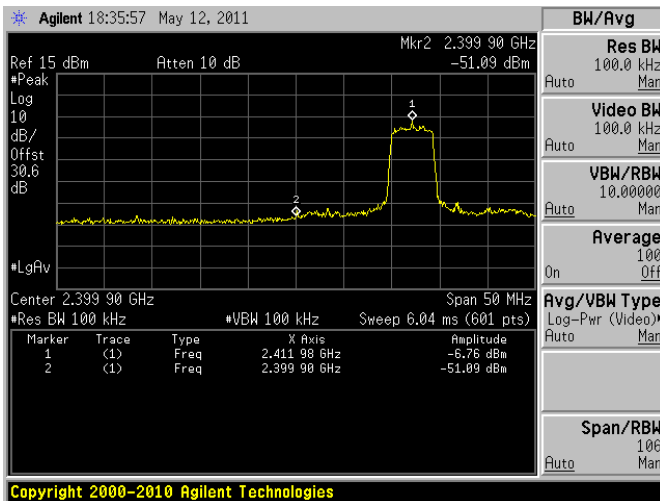

EIRP +30 dBm ~ Low Band Edge

EIRP +30 dBm ~ High Band Edge

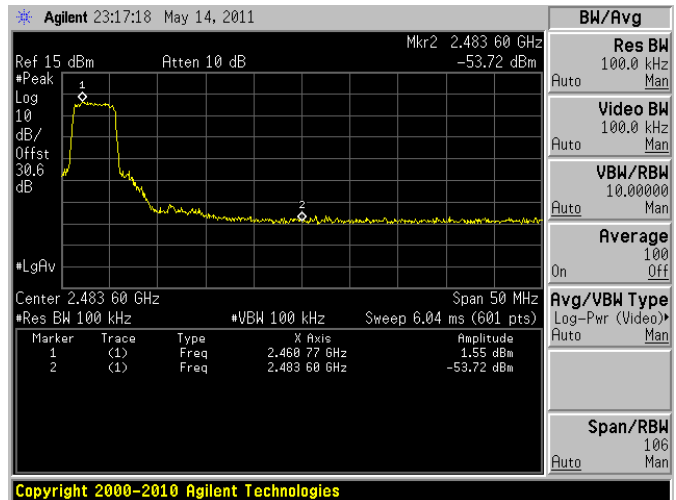
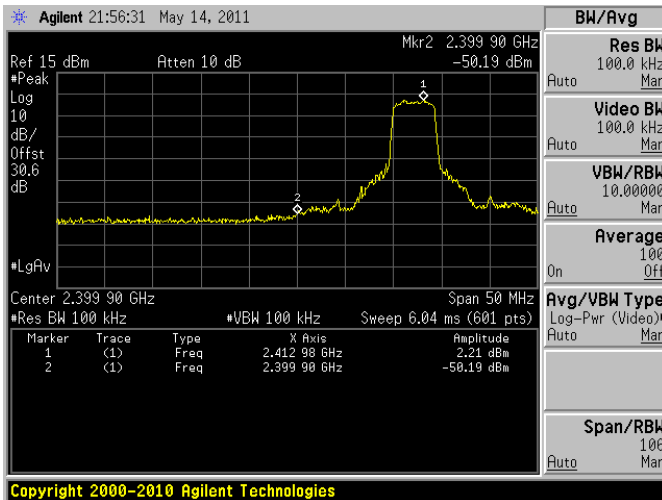

EIRP MIMO +36 dBm ~ Low Band Edge

EIRP MIMO +36 dBm ~ High Band Edge

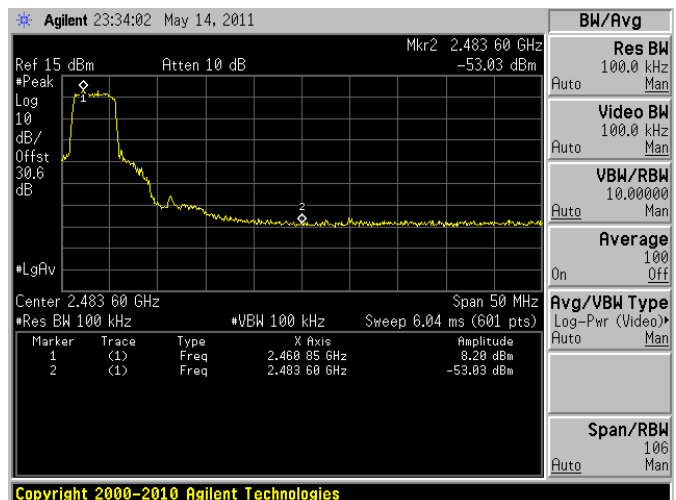
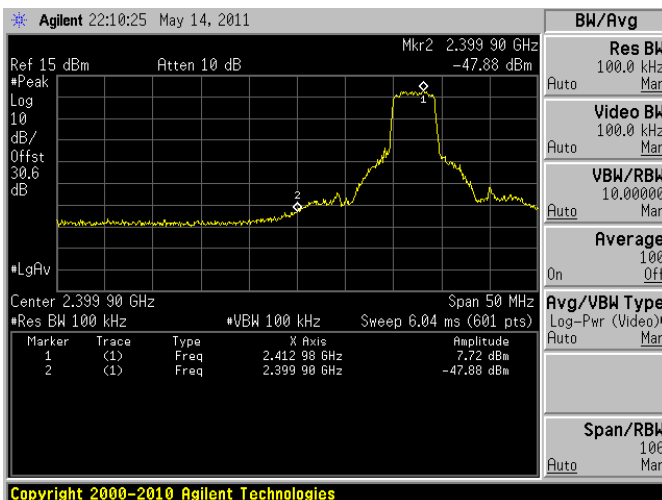

BPSK with 20 MHz Bandwidth

EIRP +20 dBm ~ Low Band Edge

EIRP +20 dBm ~ High Band Edge

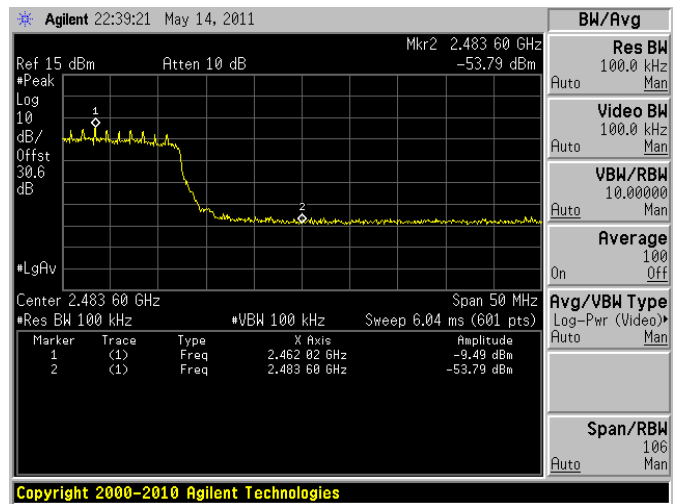
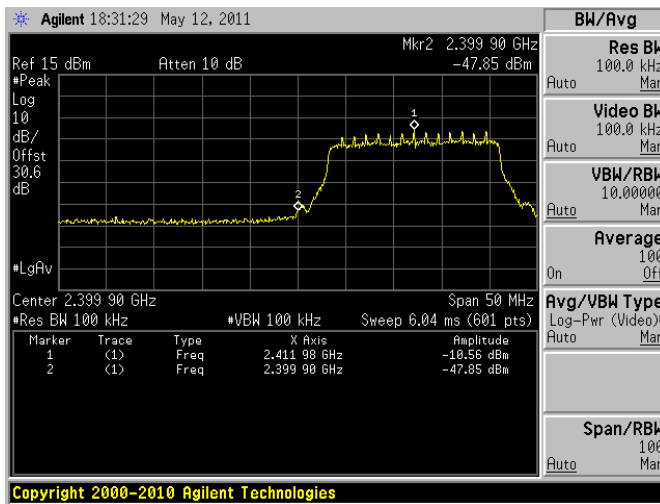

EIRP +30 dBm ~ Low Band Edge

EIRP +30 dBm ~ High Band Edge

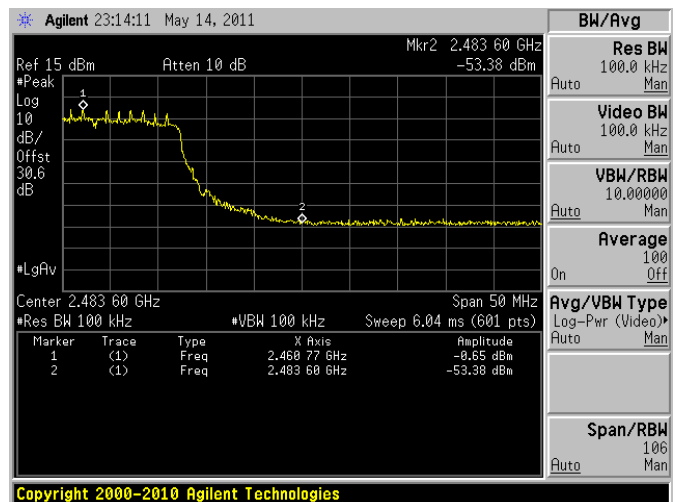
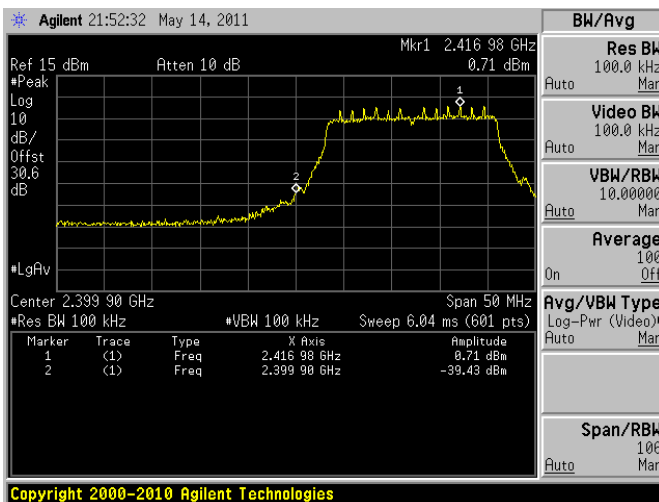



EIRP MIMO +36 dBm ~ Low Band Edge

EIRP MIMO +36 dBm ~ High Band Edge

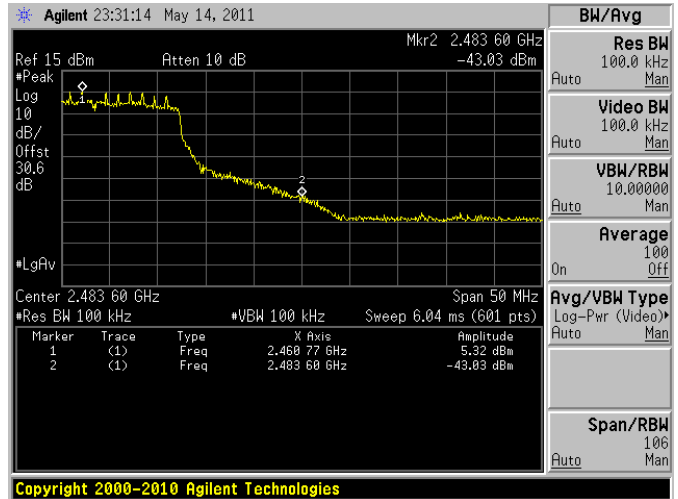
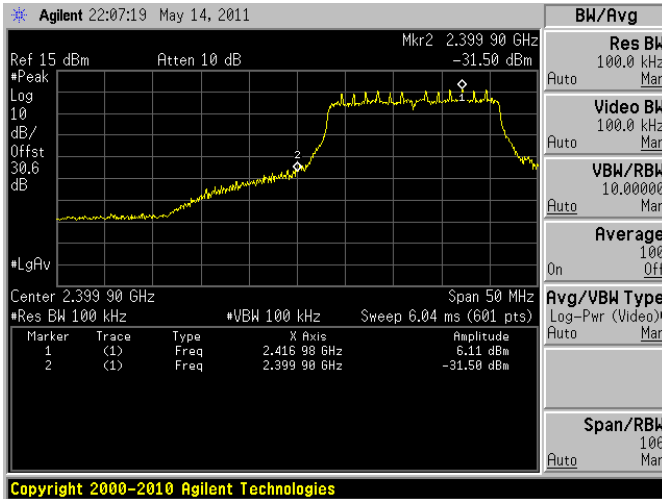

2.4 GHz, Antenna #3:

BPSK with 5 MHz Bandwidth

EIRP +20 dBm ~ Low Band Edge

EIRP +20 dBm ~ High Band Edge

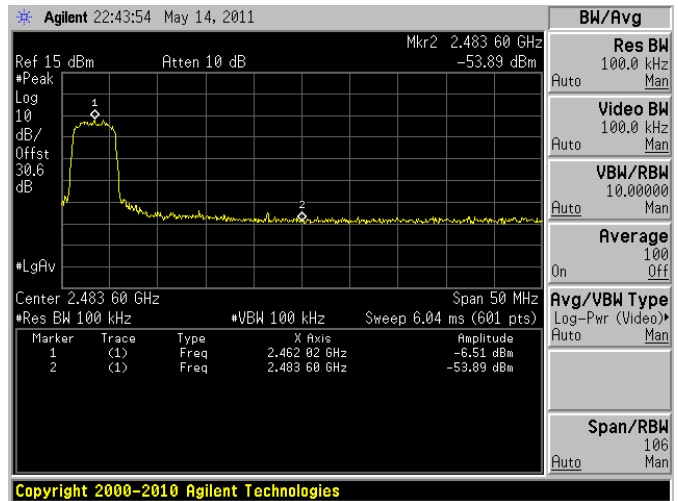
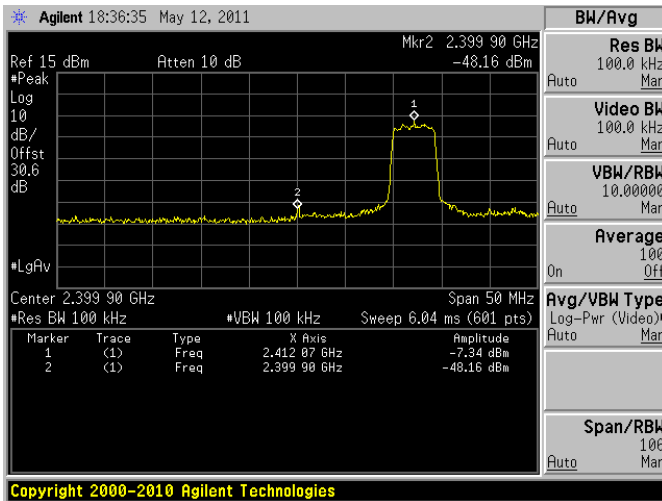

EIRP +30 dBm ~ Low Band Edge

EIRP +30 dBm ~ High Band Edge

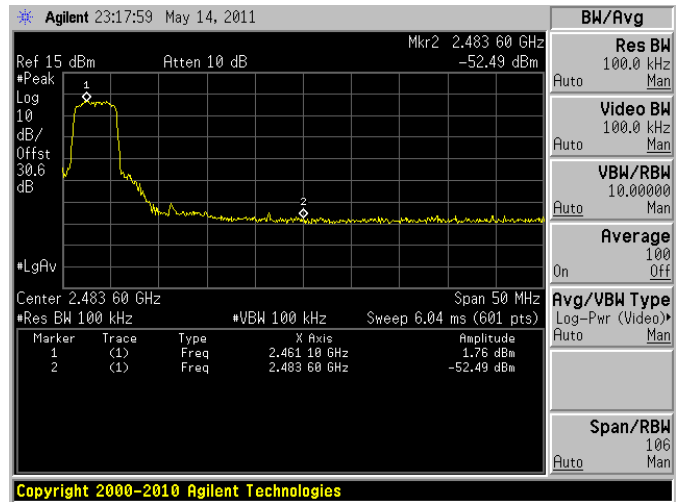
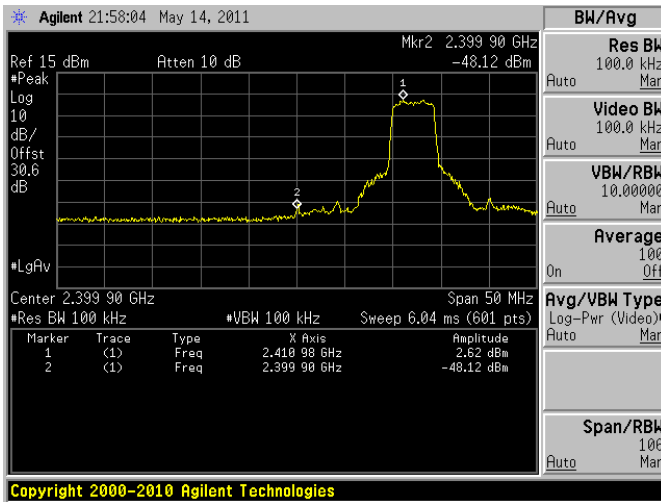

EIRP MIMO +36 dBm ~ Low Band Edge

EIRP MIMO +36 dBm ~ High Band Edge

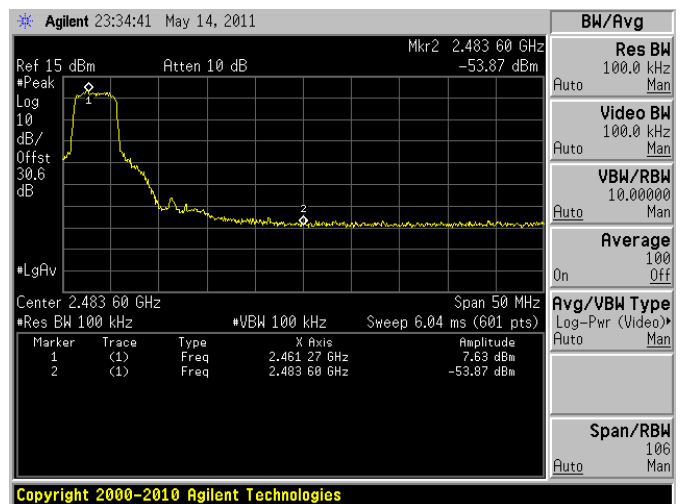
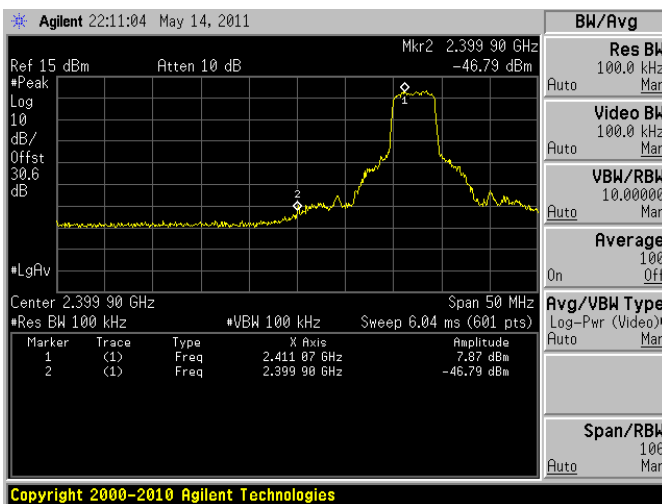

BPSK with 20 MHz Bandwidth

EIRP +20 dBm ~ Low Band Edge

EIRP +20 dBm ~ High Band Edge

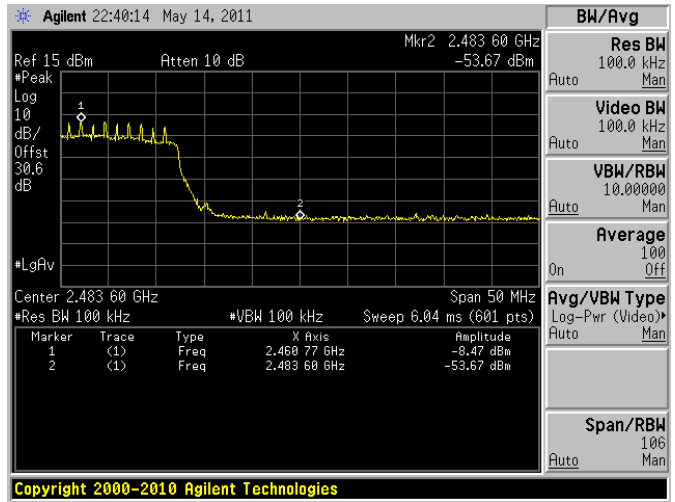
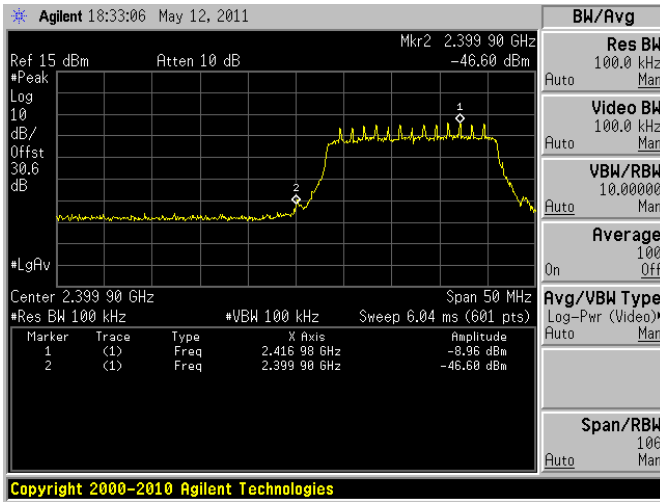

EIRP +30 dBm ~ Low Band Edge

EIRP +30 dBm ~ High Band Edge

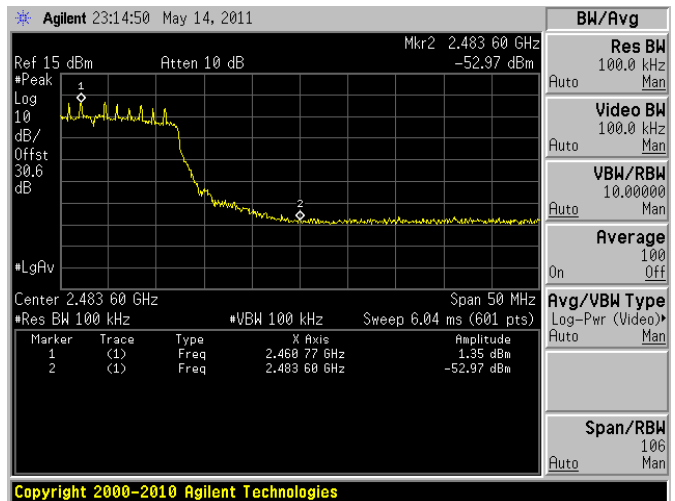
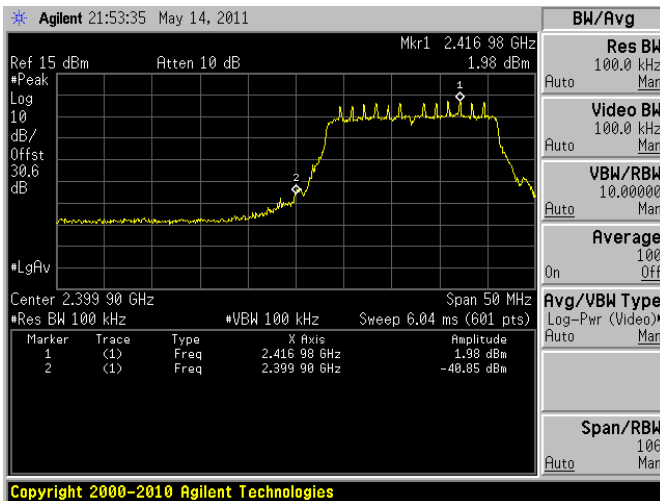

EIRP MIMO +36 dBm ~ Low Band Edge

EIRP MIMO +36 dBm ~ High Band Edge

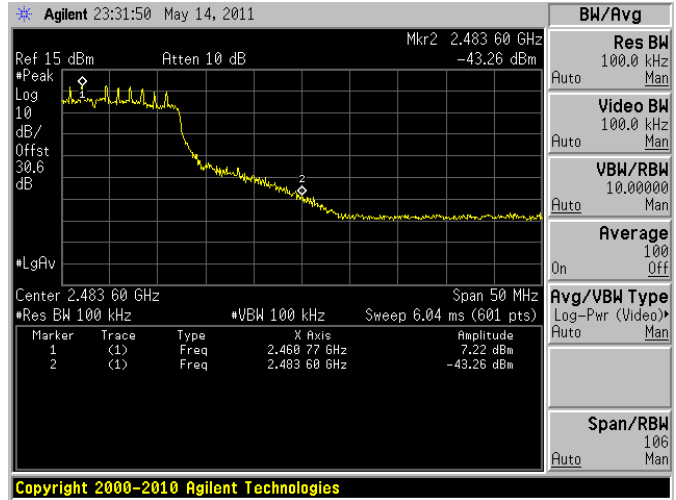
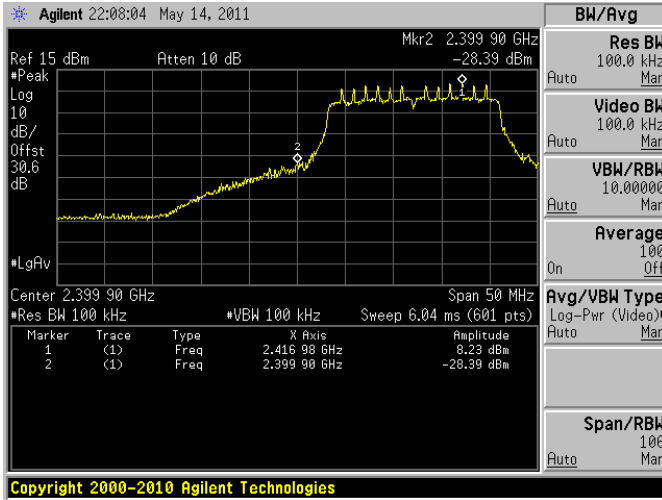

2.4 GHz, Antenna #4:

BPSK with 5 MHz Bandwidth

EIRP +20 dBm ~ Low Band Edge

EIRP +20 dBm ~ High Band Edge

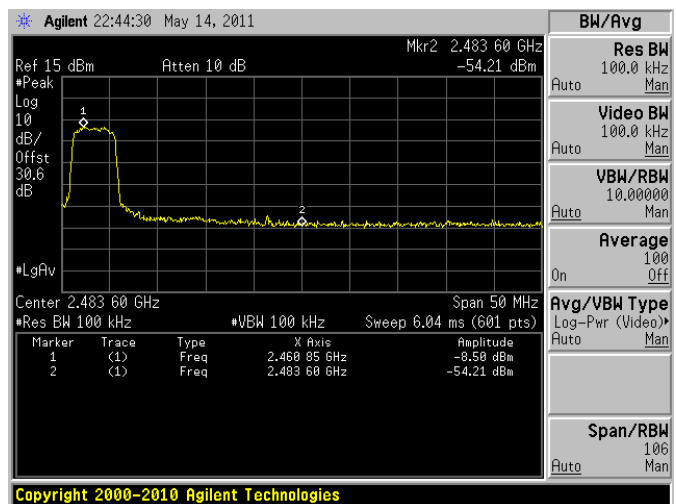
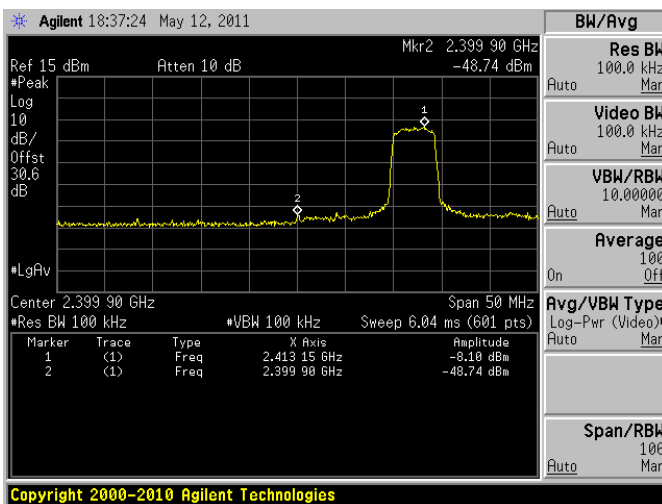

EIRP +30 dBm ~ Low Band Edge

EIRP +30 dBm ~ High Band Edge

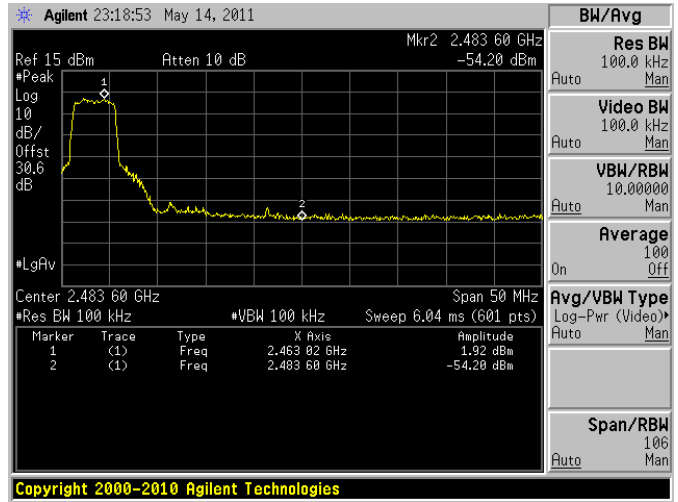
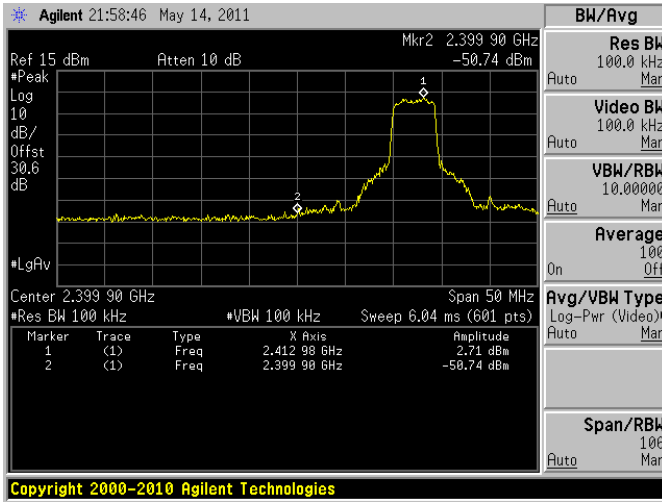

EIRP MIMO +36 dBm ~ Low Band Edge

EIRP MIMO +36 dBm ~ High Band Edge

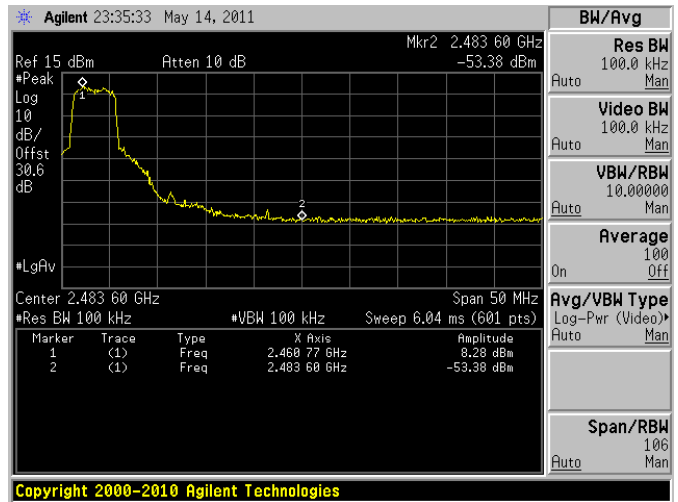
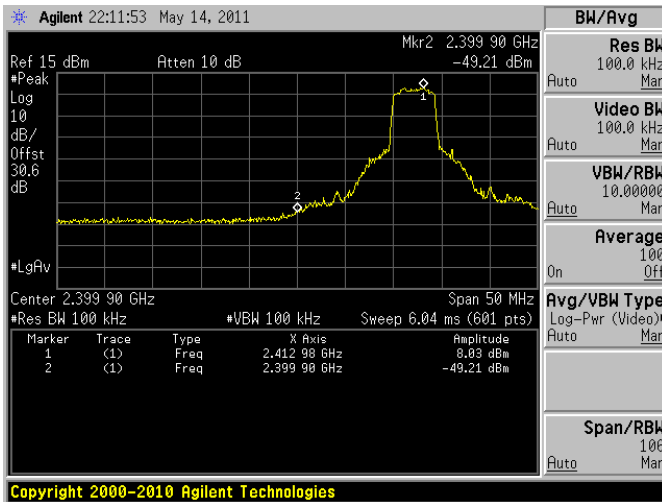

BPSK with 20 MHz Bandwidth

EIRP +20 dBm ~ Low Band Edge

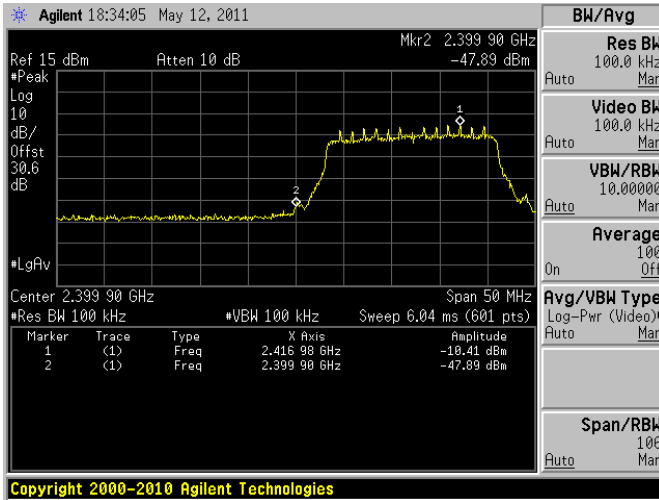

EIRP +20 dBm ~ High Band Edge

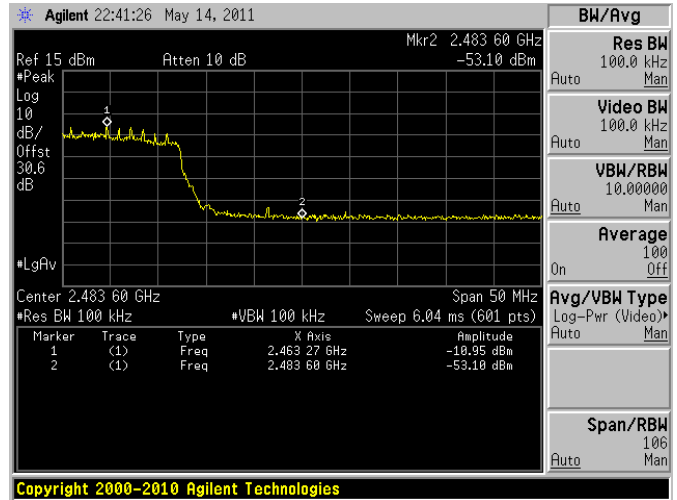

EIRP +30 dBm ~ Low Band Edge

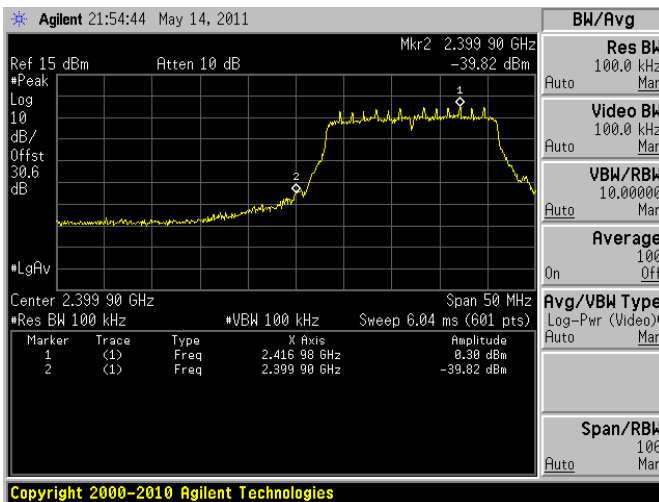

EIRP +30 dBm ~ High Band Edge

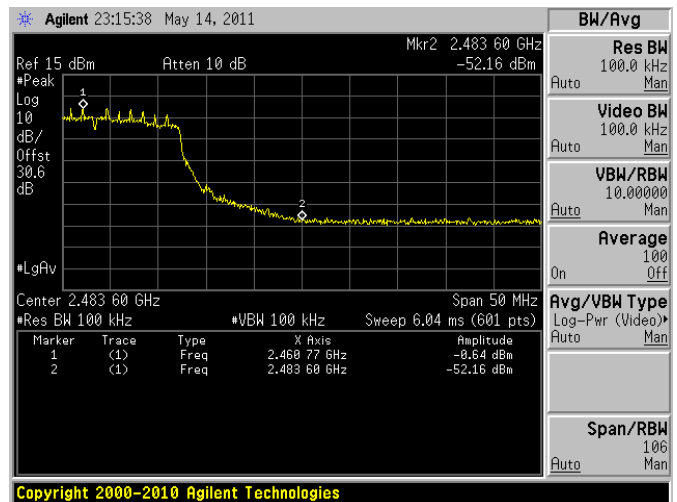

EIRP MIMO +36 dBm ~ Low Band Edge

EIRP MIMO +36 dBm ~ High Band Edge

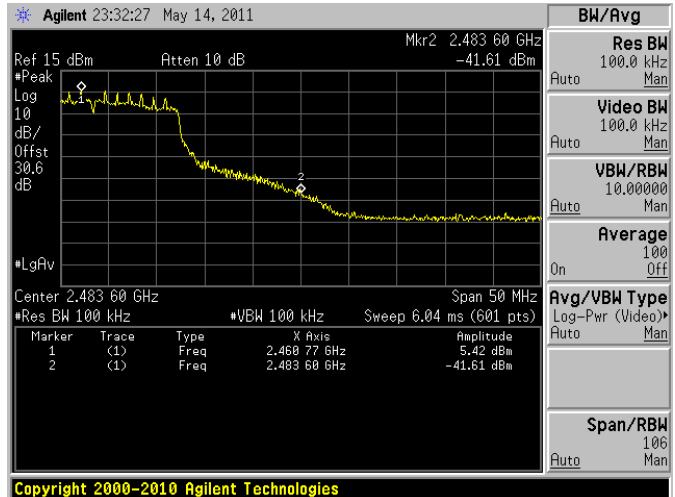
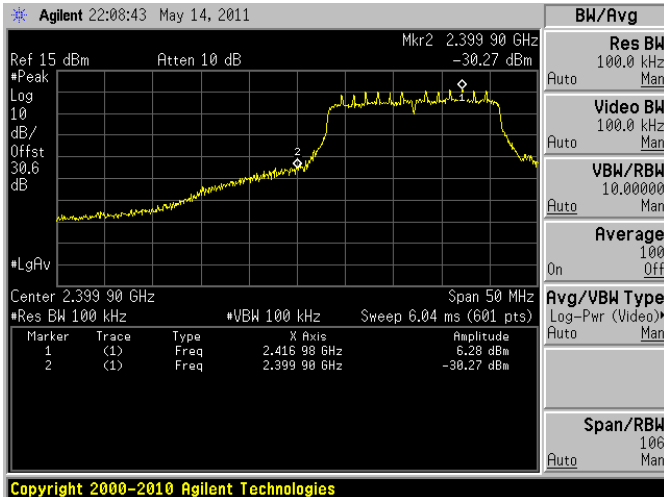

5.8 GHz Band (5745– 5825 MHz)

5.8 GHz, Antenna #1:

BPSK with 5 MHz Bandwidth

EIRP +30 dBm ~ Low Band Edge

EIRP +30 dBm ~ High Band Edge

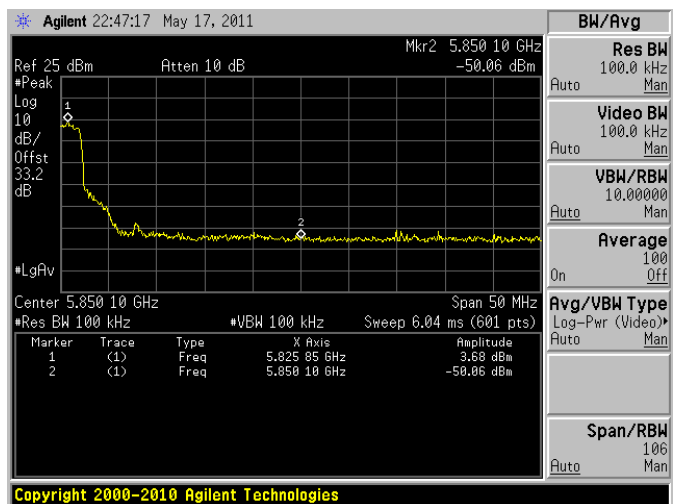
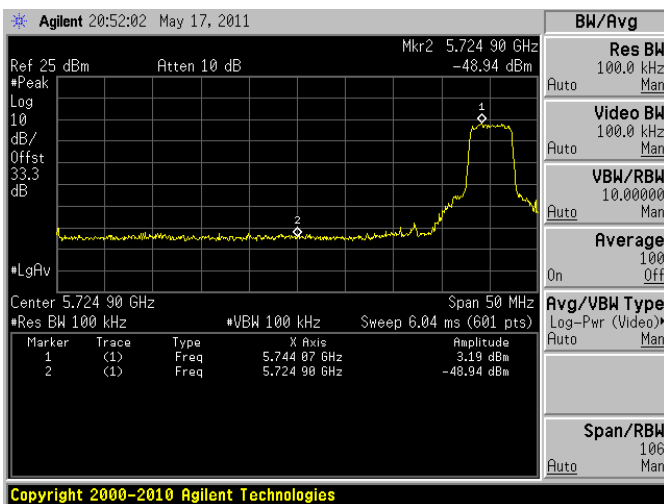

EIRP MIMO +36 dBm ~ Low Band Edge

EIRP MIMO +36 dBm ~ High Band Edge

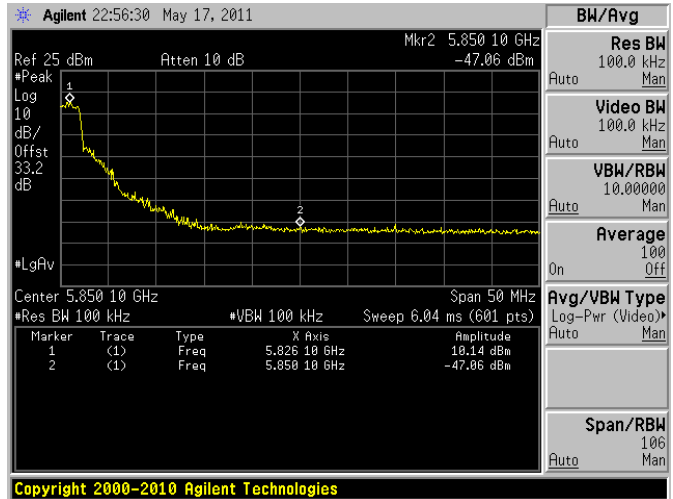
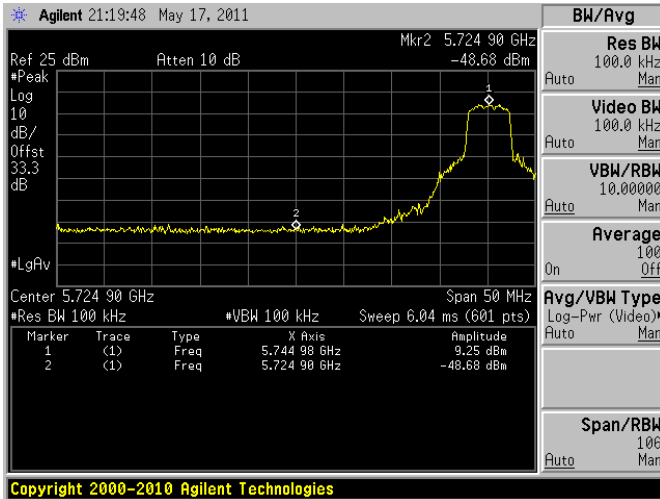

BPSK with 20 MHz Bandwidth

EIRP +30 dBm ~ Low Band Edge

EIRP +30 dBm ~ High Band Edge

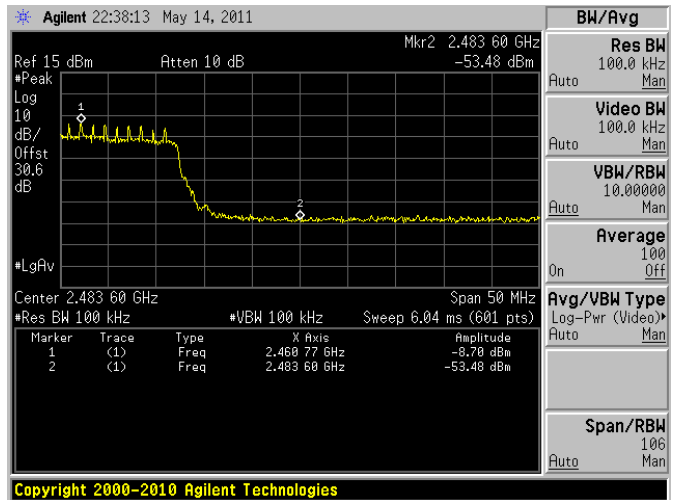
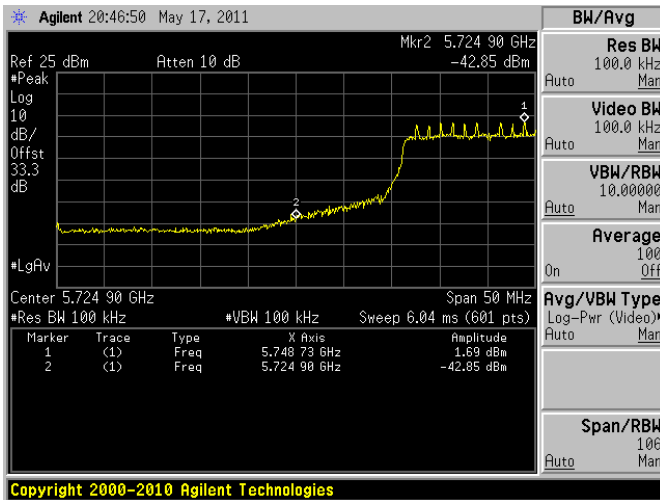



EIRP MIMO +36 dBm ~ Low Band Edge

EIRP MIMO +36 dBm ~ High Band Edge

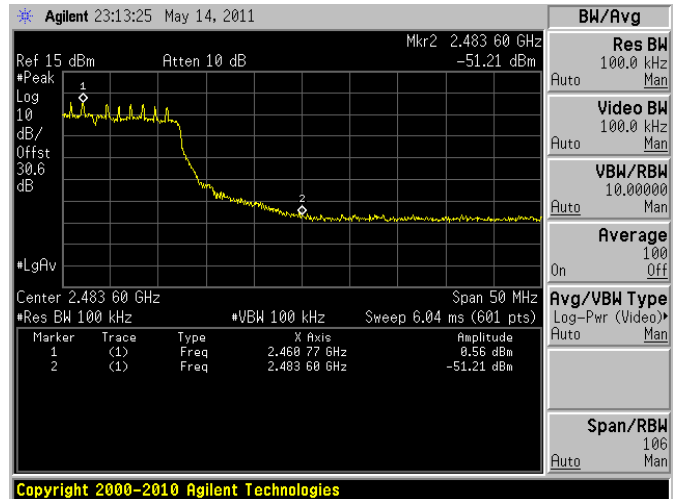
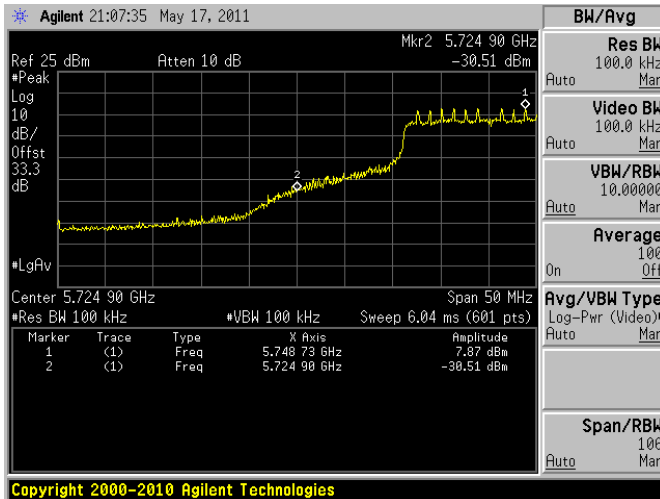

5.8 GHz, Antenna #2:

BPSK with 5 MHz Bandwidth

EIRP +30 dBm ~ Low Band Edge

EIRP +30 dBm ~ High Band Edge

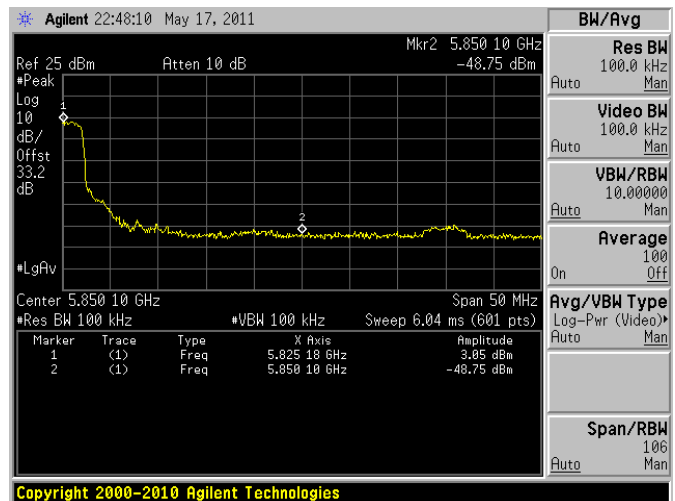
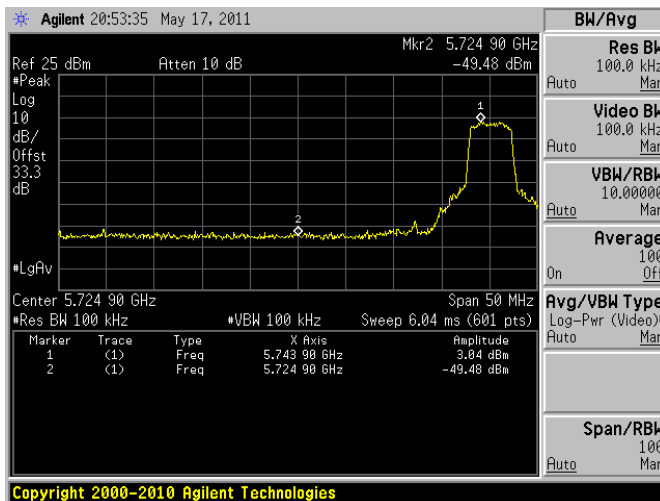

EIRP MIMO +36 dBm ~ Low Band Edge

EIRP MIMO +36 dBm ~ High Band Edge

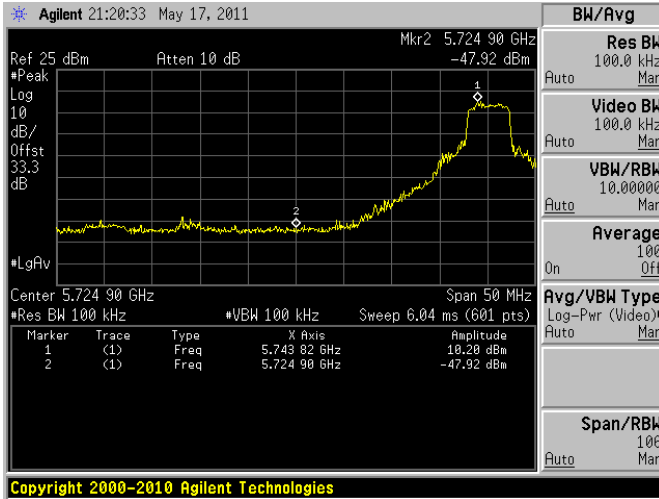

BPSK with 20 MHz Bandwidth

EIRP +30 dBm ~ Low Band Edge

EIRP +30 dBm ~ High Band Edge

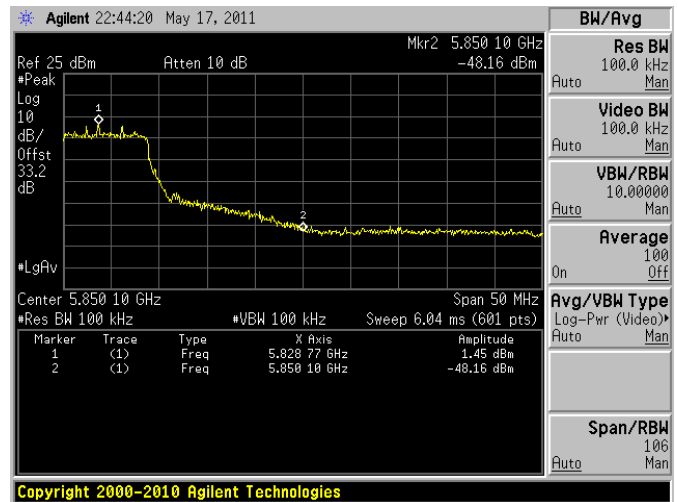
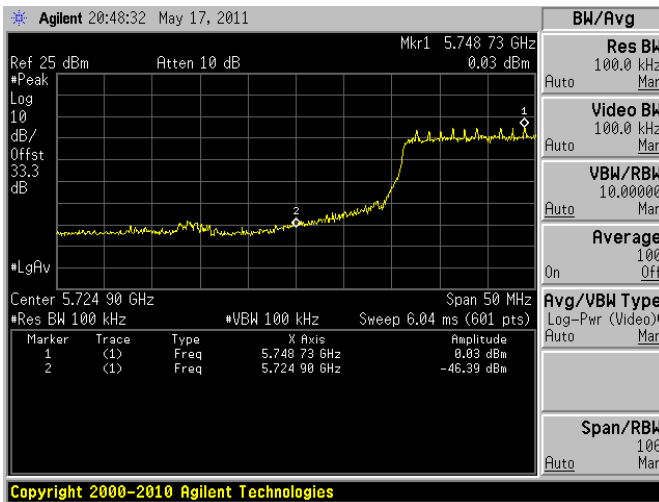

EIRP MIMO +36 dBm ~ Low Band Edge

EIRP MIMO +36 dBm ~ High Band Edge

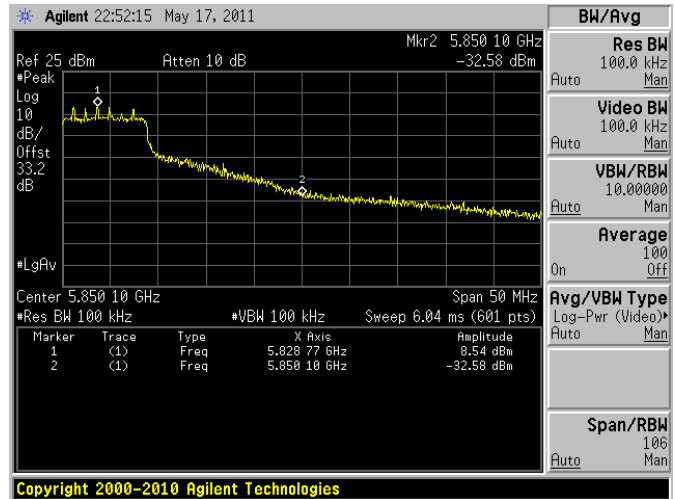
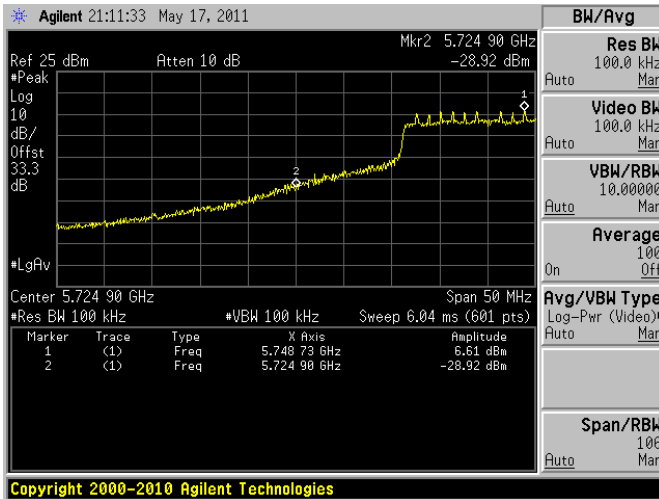

5.8 GHz, Antenna #3:

BPSK with 5 MHz Bandwidth

EIRP +30 dBm ~ Low Band Edge

EIRP +30 dBm ~ High Band Edge

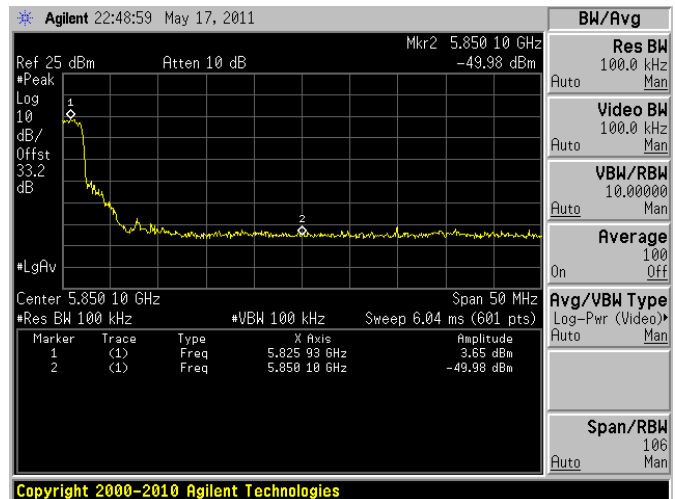
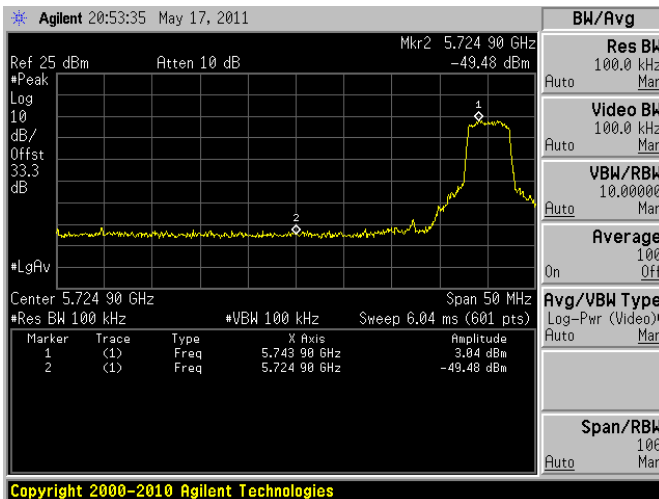

EIRP MIMO +36 dBm ~ Low Band Edge

EIRP MIMO +36 dBm ~ High Band Edge

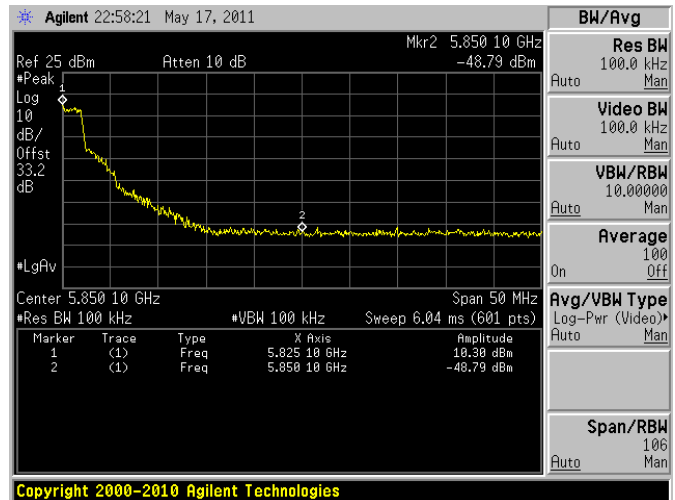
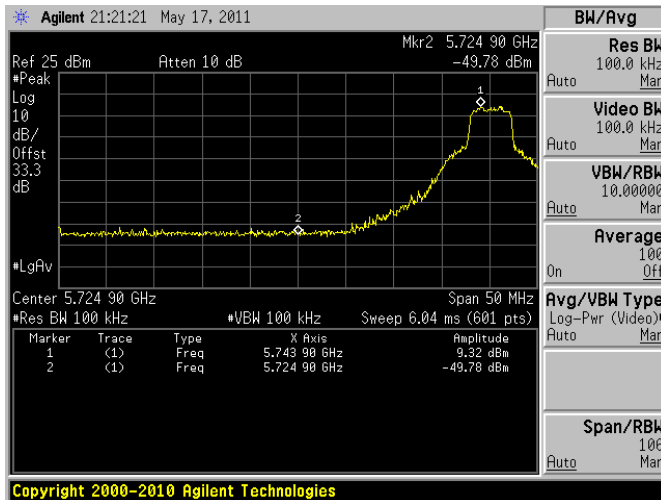

BPSK with 20 MHz Bandwidth

EIRP +30 dBm ~ Low Band Edge

EIRP +30 dBm ~ High Band Edge

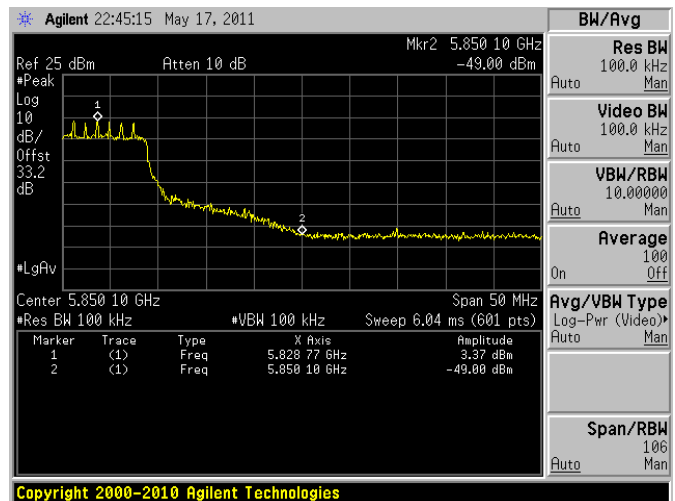
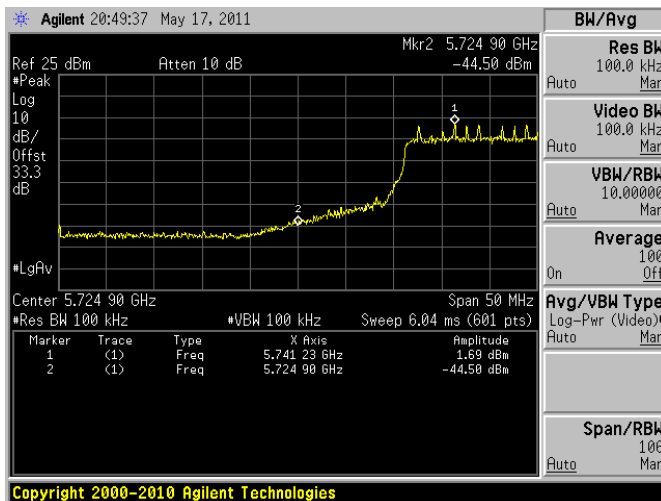

EIRP MIMO +36 dBm ~ Low Band Edge

EIRP MIMO +36 dBm ~ High Band Edge

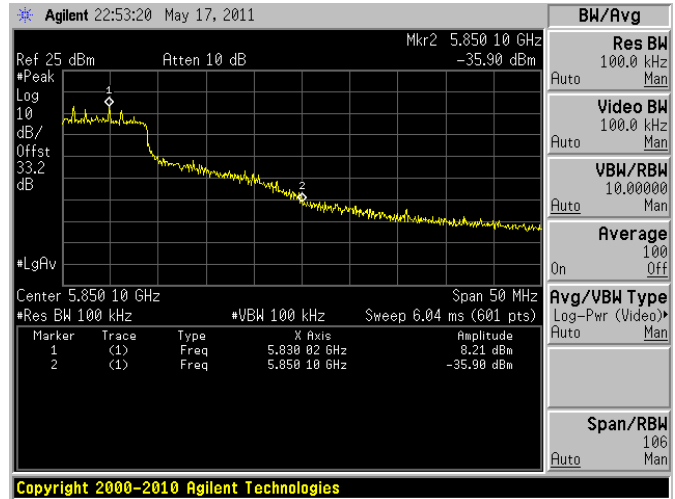
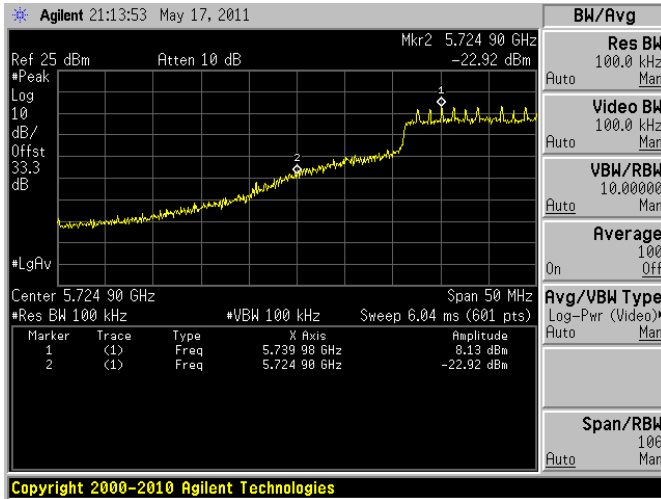

5.8 GHz, Antenna #4:

BPSK with 5 MHz Bandwidth

EIRP +30 dBm ~ Low Band Edge

EIRP +30 dBm ~ High Band Edge

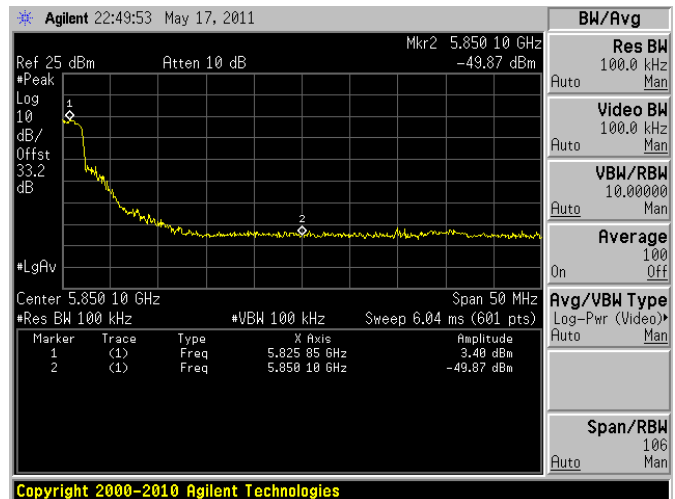
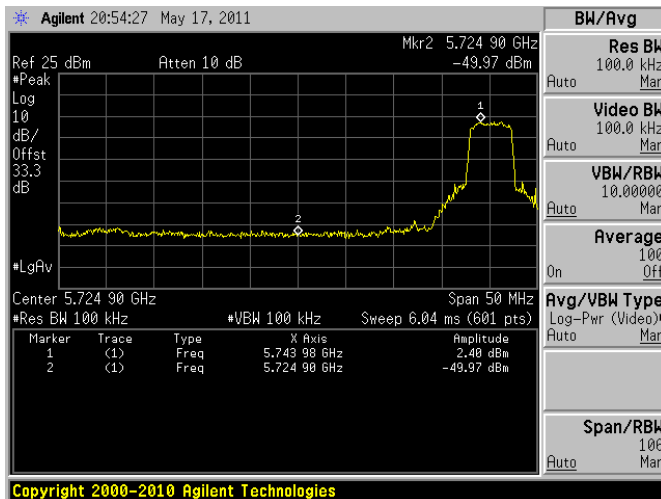

EIRP MIMO +36 dBm ~ Low Band Edge

EIRP MIMO +36 dBm ~ High Band Edge

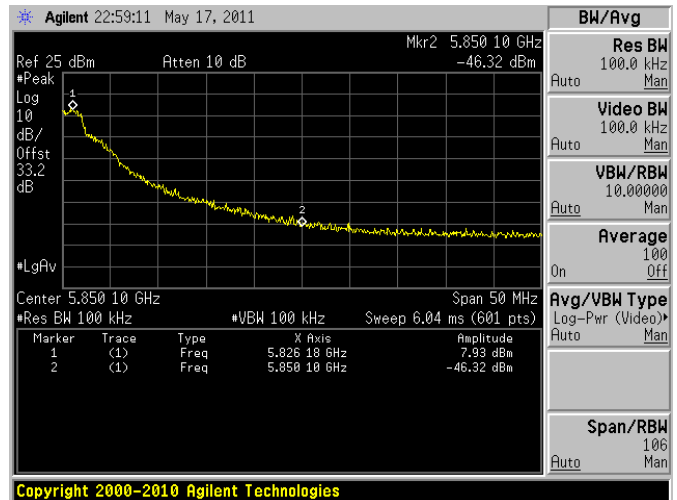
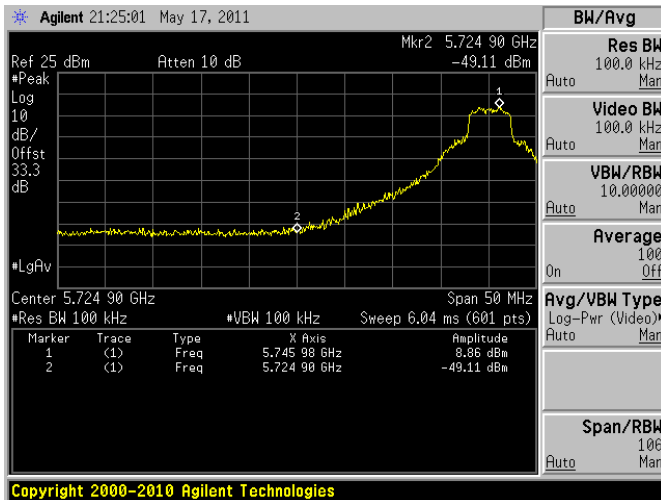

BPSK with 20 MHz Bandwidth

EIRP +30 dBm ~ Low Band Edge

EIRP +30 dBm ~ High Band Edge

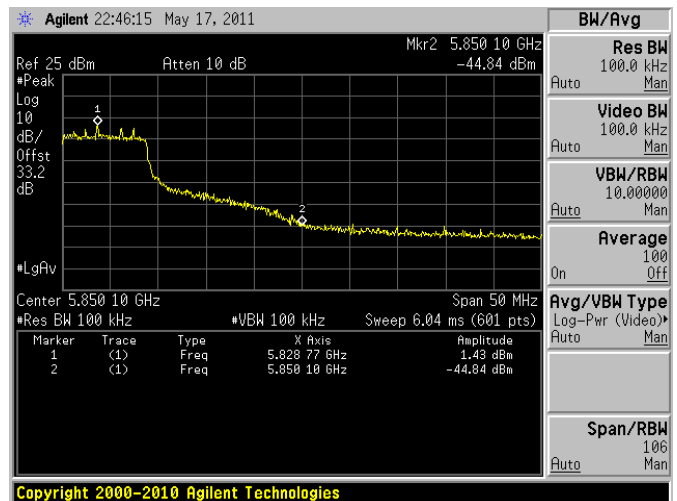
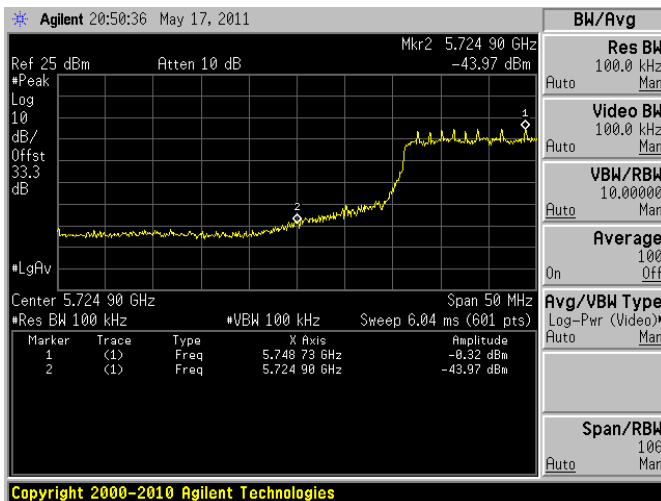

EIRP MIMO +36 dBm ~ Low Band Edge

EIRP MIMO +36 dBm ~ High Band Edge

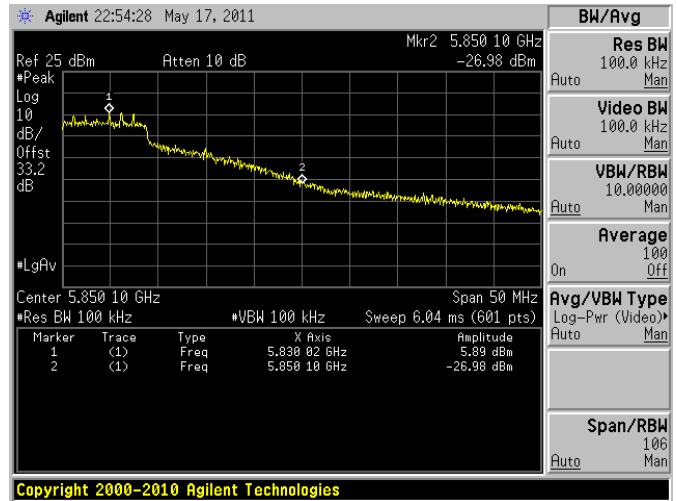
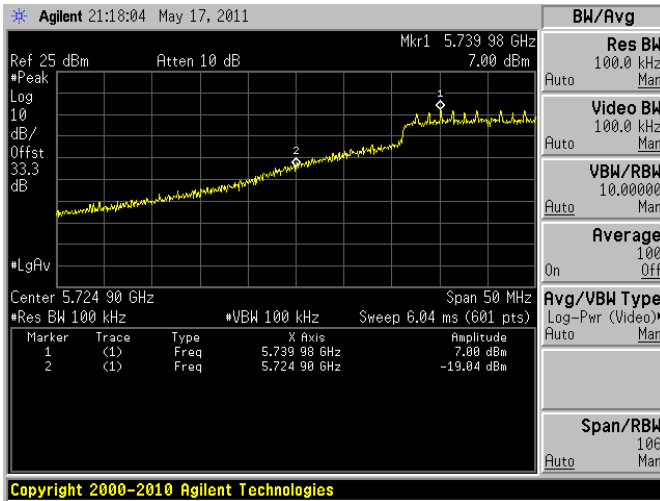

## 12 FCC §15.247(e) & IC RSS-210 §A8.2(b) - Power Spectral Density

### 12.1 Applicable Standard

According to FCC §15.247 (e) and IC RSS-210 §A8.2( b) , for digitally modulated systems, the power spectral density conducted from the intentional radiator to the antenna shall not be greater than 8 dBm in any 3 kHz band during any time interval of continuous transmission.

### 12.2 Measurement Procedure

1. Check the calibration of the measuring instrument using either an internal calibrator or a known signal from an external generator.
2. Position the EUT was set without connection to measurement instrument. Turn on the EUT and connect its antenna terminal to measurement instrument via a low loss cable. Then set it to any one measured frequency within its operating range, and make sure the instrument is operated in its linear range.
3. Adjust the center frequency of SA on any frequency be measured and set SA to 1.5MHz span mode. And then, set RBW and VBW of spectrum analyzer to proper value.
4. Repeat above procedures until all frequencies measured were complete.

### 12.3 Test Equipment List and Details

Manufacturers	Description	Models	Serial Numbers	Calibration Dates
Agilent	Spectrum Analyzer	E4445A	MY44020562	2011-04-05

**Statement of Traceability:** BACL Corp. attests that all calibrations have been performed per the NVLAP requirements, traceable to the NIST.

### 12.4 Test Environmental Conditions

<b>Temperature:</b>	16.5~27°C
<b>Relative Humidity:</b>	30.9~43.3 %
<b>ATM Pressure:</b>	101-103 kPa

*The testing was performed by Brian Fox on 2011-05-13 ~ 2011-05-20.*

### 12.5 Test Results

Please refer to the following tables and plots.



## 2.4 GHz Band, BPSK with 5 MHz Bandwidth:

Radio Mode	Channel	Frequency (MHz)	Power Spectral Density (dBm)				Total PSD (dBm)	FCC/IC Limit (dBm)	Result
			Ant #1	Ant #2	Ant #3	Ant #4			
EIRP +20 dBm	Low	2412	-10.81	-11.4	-12.37	-15.58	-6.18	8	Compliance
	Mid	2437	-11.23	-10.53	-12.39	-15.65	-6.04	8	Compliance
	High	2462	-10.84	-10.92	-11.63	-15.82	-5.88	8	Compliance
EIRP +30 dBm	Low	2412	-4.73	-6.17	-5.02	-6.48	0.48	8	Compliance
	Mid	2437	-5.84	-7.15	-5.22	-6.57	-0.11	8	Compliance
	High	2462	-5.54	-7.37	-4.78	-6.83	0.01	8	Compliance

## 2.4 GHz Band, BPSK with 20 MHz Bandwidth:

Radio Mode	Channel	Frequency (MHz)	Power Spectral Density (dBm)				Total PSD (dBm)	FCC/IC Limit (dBm)	Result
			Ant #1	Ant #2	Ant #3	Ant #4			
EIRP +20 dBm	Low	2412	-10.9	-11.63	-12.78	-16.02	-6.43	8	Compliance
	Mid	2437	-11.31	-11.68	-12.72	-15.98	-6.56	8	Compliance
	High	2462	-10.93	-10.92	-11.68	-16.22	-5.96	8	Compliance
EIRP +30 dBm	Low	2412	-12.05	-10.65	-10.74	-14.89	-5.76	8	Compliance
	Mid	2437	-11.35	-11.36	-11.47	-13.84	-5.87	8	Compliance
	High	2462	-12.05	-11.68	-11.06	-14.33	-6.10	8	Compliance

## 5.8 GHz Band, BPSK with 5 MHz Bandwidth:

Radio Mode	Channel	Frequency (MHz)	Power Spectral Density (dBm)				Total PSD (dBm)	FCC/IC Limit (dBm)	Result
			Ant #1	Ant #2	Ant #3	Ant #4			
EIRP +20 dBm	Low	5745	-4.38	-6.01	-3.65	-5.77	1.18	8	Compliance
	Mid	5785	-3.77	-5.69	-3.31	-5.32	1.61	8	Compliance
	High	5825	-4.35	-6.27	-3.04	-4.39	1.65	8	Compliance
EIRP +30 dBm	Low	5745	1.39	0.73	2.04	1.03	7.35	8	Compliance
	Mid	5785	2.51	1.02	1.77	-0.61	7.34	8	Compliance
	High	5825	1.90	1.05	2.00	-0.41	7.26	8	Compliance

## 5.8GHz Band, BPSK with 20 MHz Bandwidth:

Radio Mode	Channel	Frequency (MHz)	Power Spectral Density (dBm)				Total PSD (dBm)	FCC/IC Limit (dBm)	Result
			Ant #1	Ant #2	Ant #3	Ant #4			
EIRP +20 dBm	Low	5745	-6.88	-7.72	-6	-9.33	-1.30	8	Compliance
	Mid	5785	-5.67	-7.46	-5.11	-8.34	-0.43	8	Compliance
	High	5825	-6.58	-7.23	-5.07	-7.46	-0.46	8	Compliance
EIRP +30 dBm	Low	5745	-0.44	-1.51	0.26	-2.62	5.08	8	Compliance
	Mid	5785	-0.22	-0.7	0.44	-3.98	5.20	8	Compliance
	High	5825	-0.12	-0.61	0.37	-3.51	5.28	8	Compliance

**2.4 GHz Band (2412–2462 MHz): BPSK with 5 MHz bandwidth**

**2.4 GHz, Antenna #1:**

EIRP +20 dBm ~ Low Channel

EIRP +20 dBm ~ Middle Channel

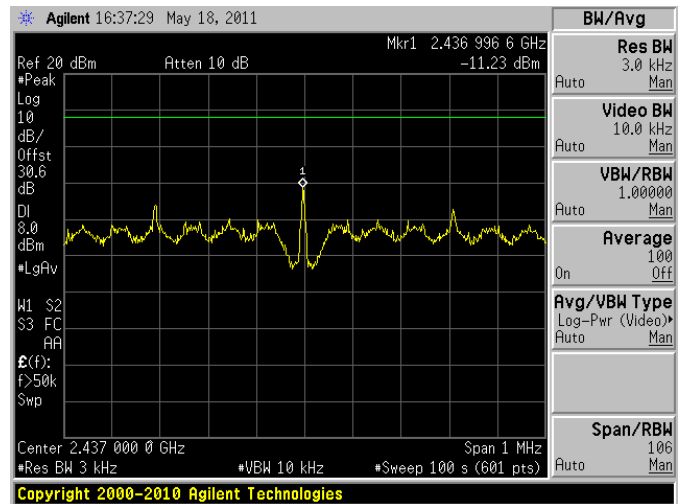
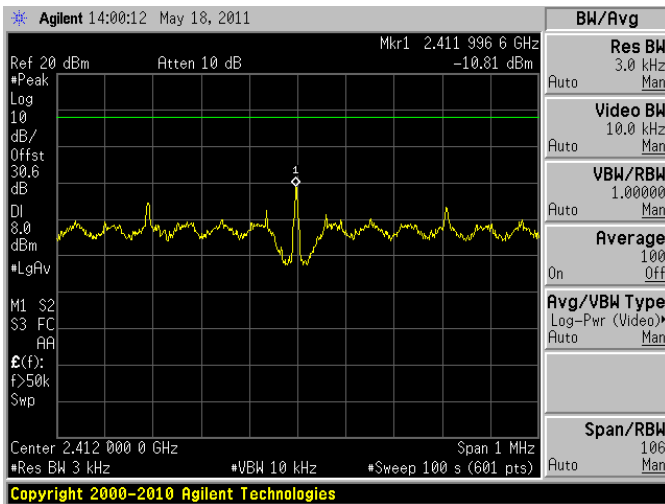

EIRP +20 dBm ~ High Channel

EIRP +30 dBm ~ Low Channel

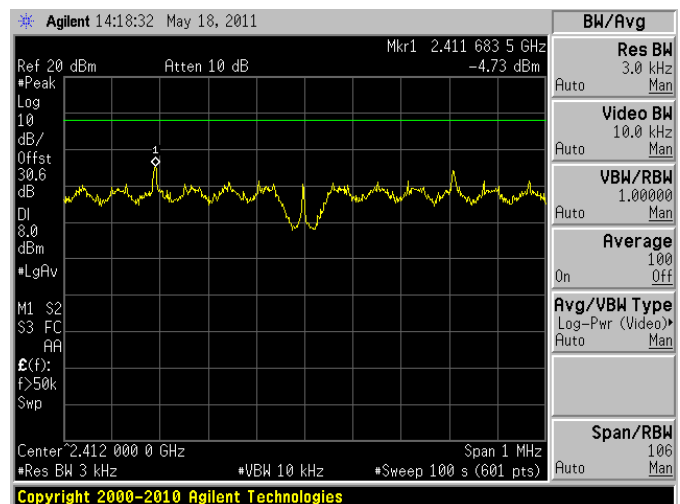
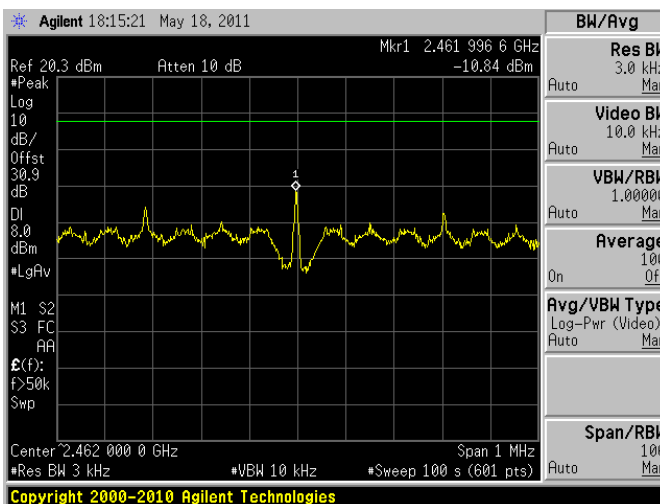

EIRP +30 dBm ~ Middle Channel

EIRP +30 dBm ~ High Channel

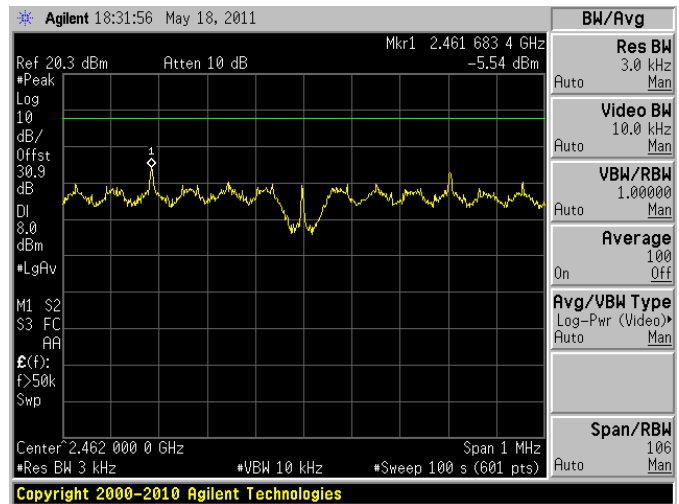
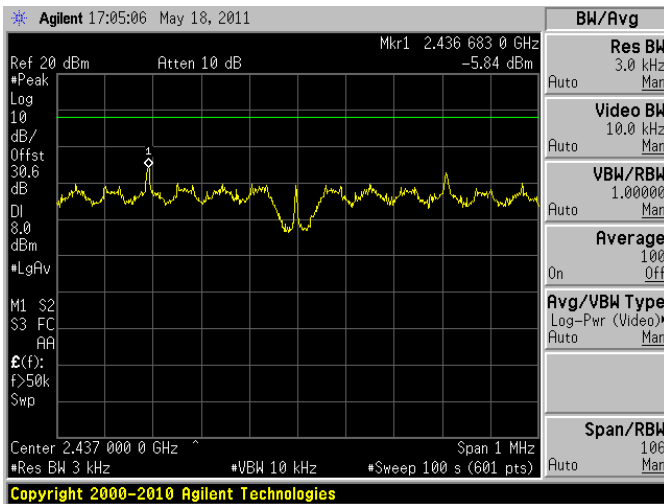

2.4 GHz, Antenna #2:

EIRP +20 dBm ~ Low Channel

EIRP +20 dBm ~ Middle Channel

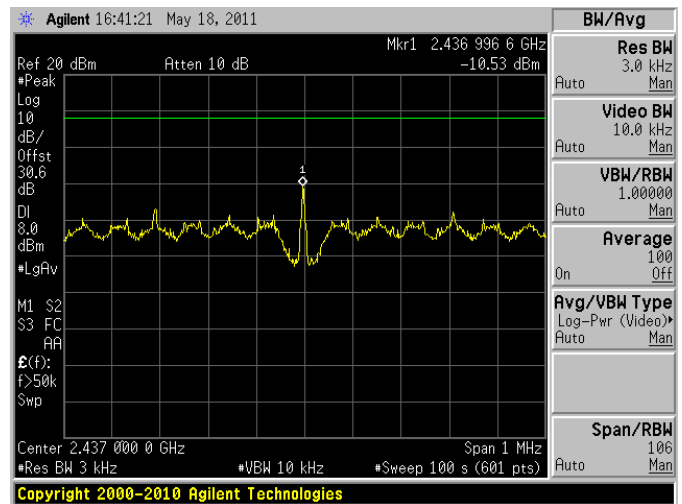
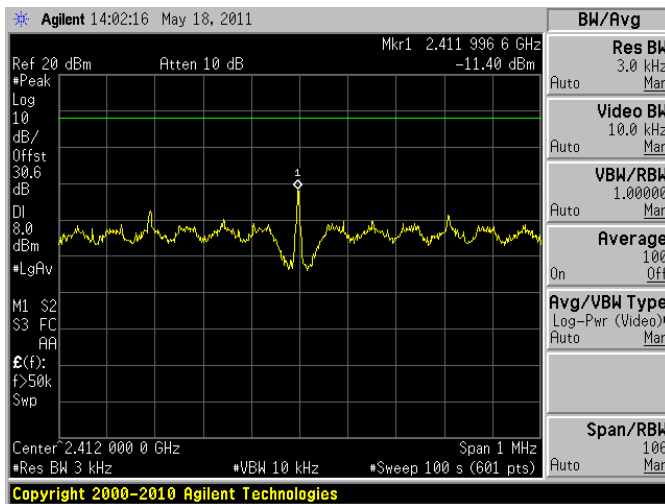

EIRP +20 dBm ~ High Channel

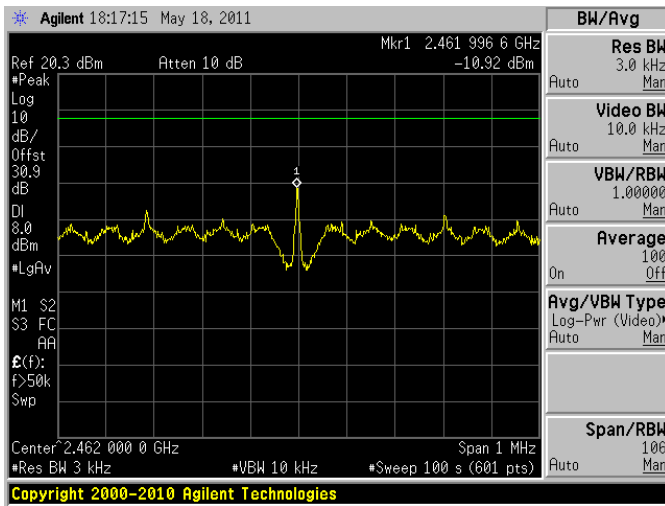

EIRP +30 dBm ~ Low Channel

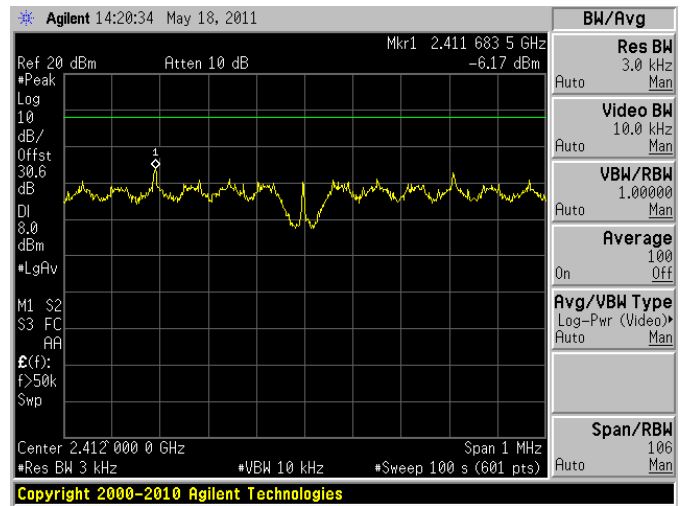

EIRP +30 dBm ~ Middle Channel

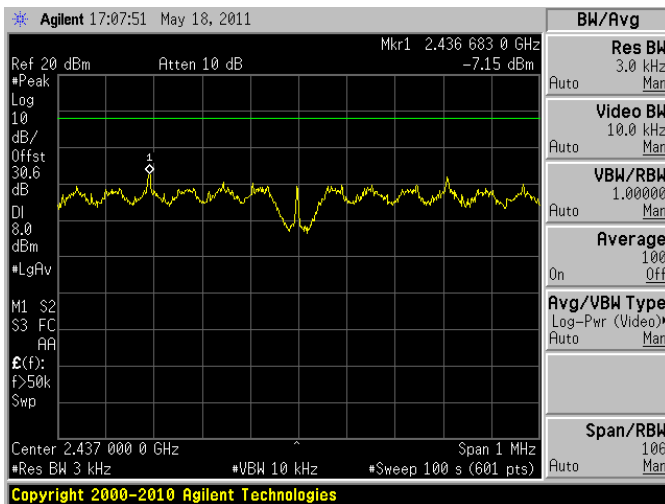

EIRP +30 dBm ~ High Channel

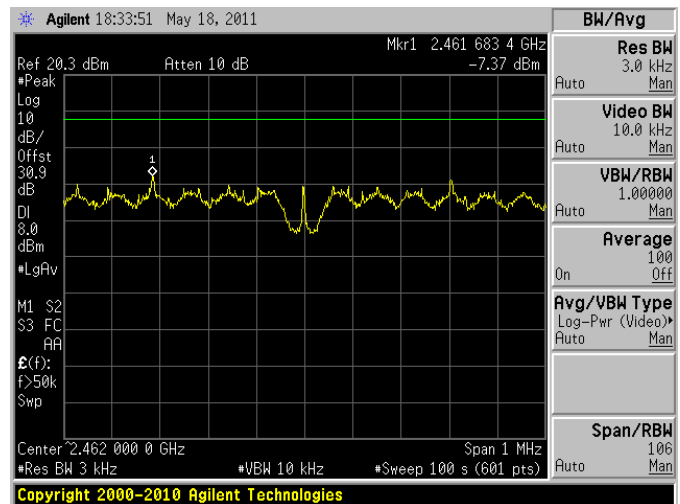

2.4 GHz, Antenna #3:

EIRP +20 dBm ~ Low Channel

EIRP +20 dBm ~ Middle Channel

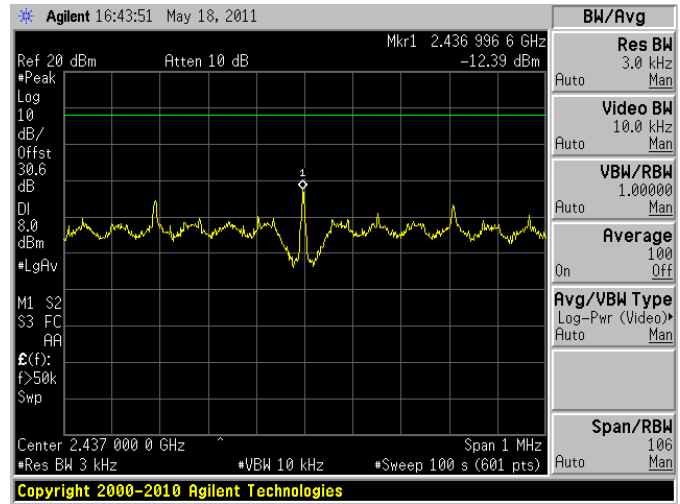
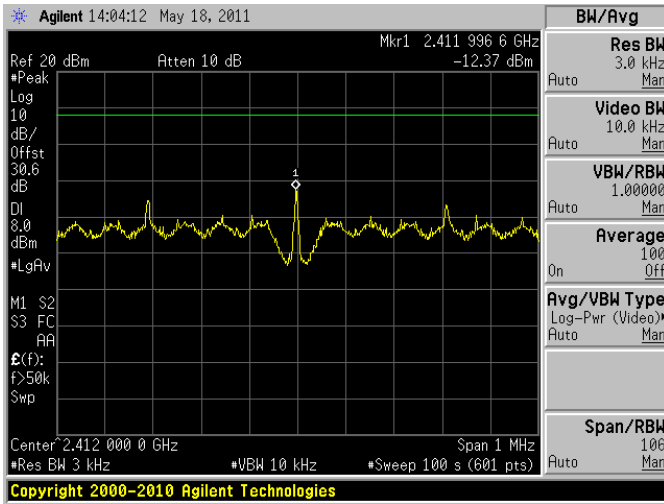

EIRP +20 dBm ~ High Channel

EIRP +30 dBm ~ Low Channel

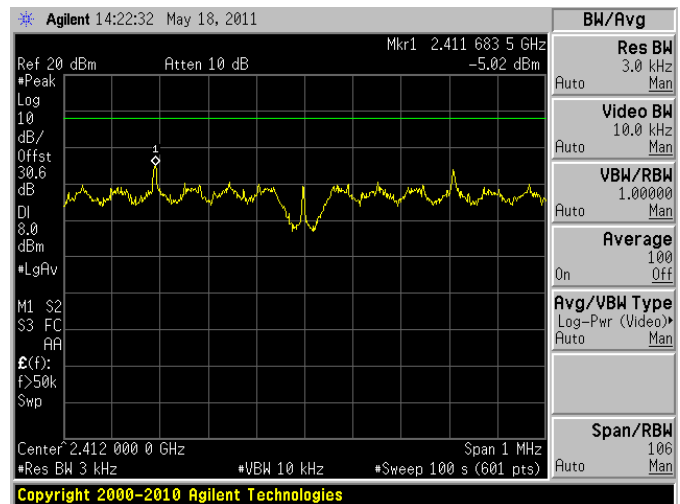
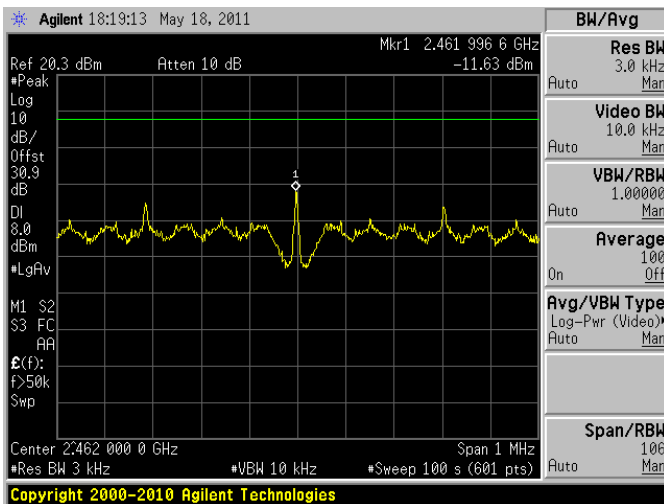

EIRP +30 dBm ~ Middle Channel

EIRP +30 dBm ~ High Channel

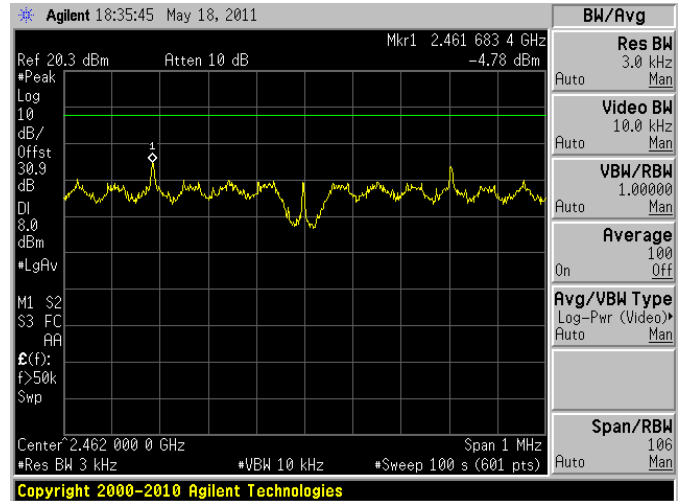
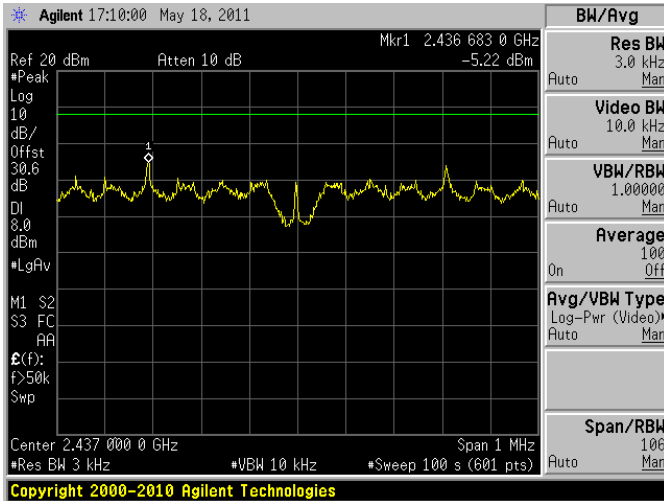

2.4 GHz, Antenna #4:

EIRP +20 dBm ~ Low Channel

EIRP +20 dBm ~ Middle Channel

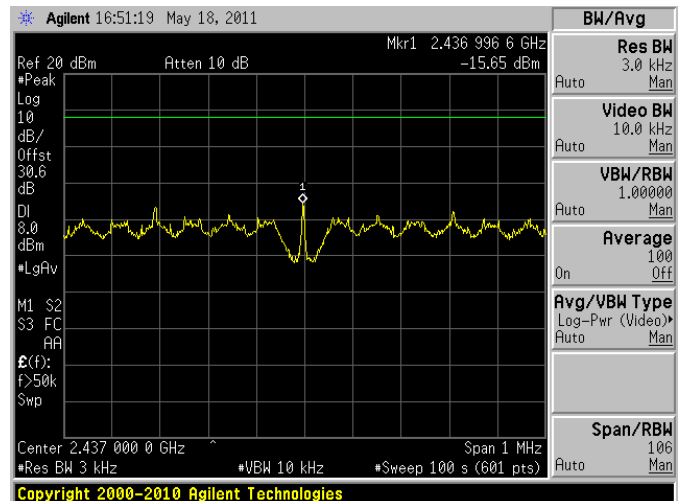
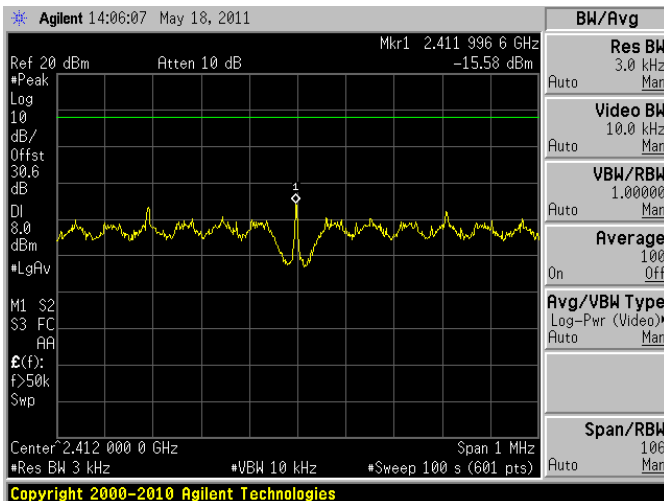

EIRP +20 dBm ~ High Channel

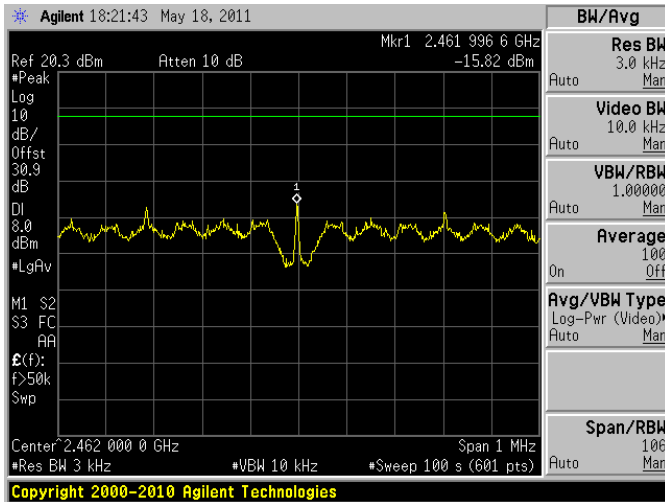

EIRP +30 dBm ~ Low Channel

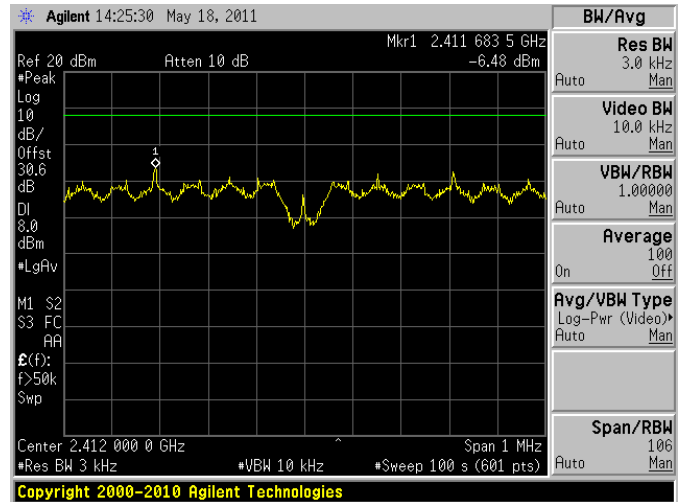

EIRP +30 dBm ~ Middle Channel

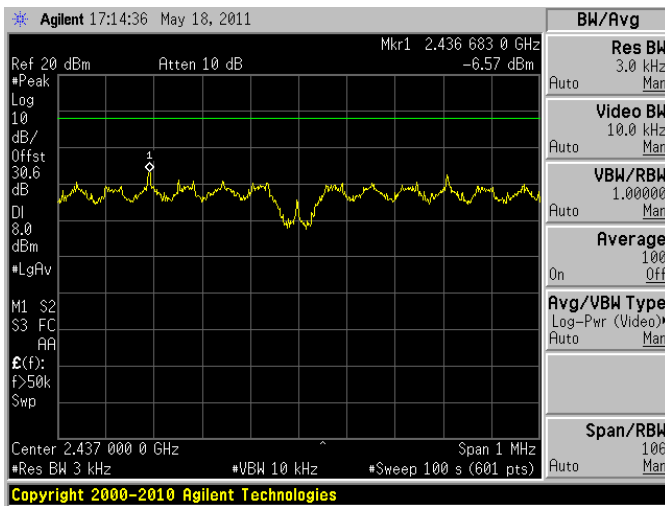

EIRP +30 dBm ~ High Channel

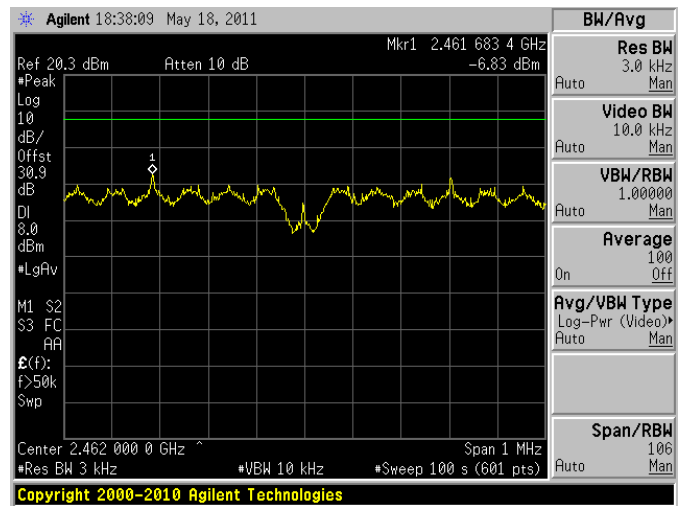

**2.4 GHz Band (2412-2462 MHz): BPSK with 20 MHz bandwidth**

**2.4 GHz, Antenna #1:**

EIRP +20 dBm ~ Low Channel

EIRP +20 dBm ~ Middle Channel

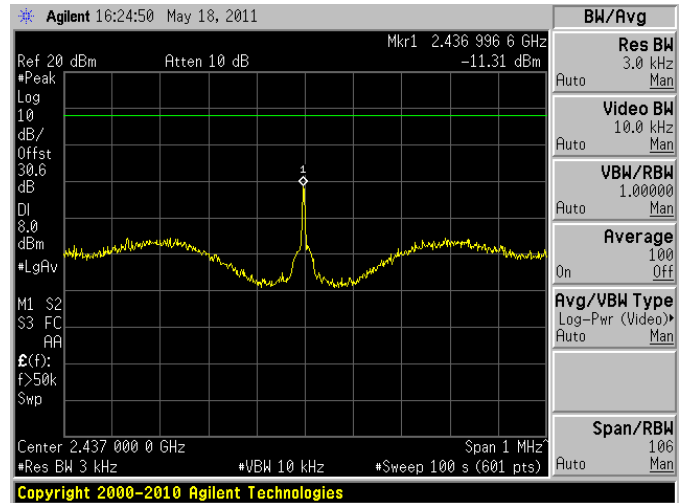
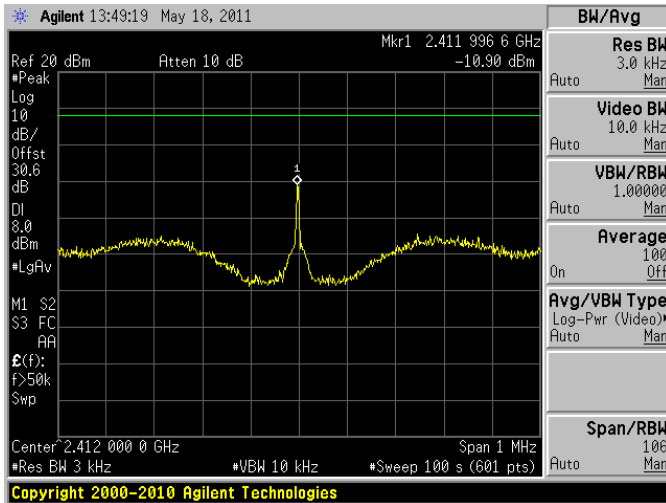

EIRP +20 dBm ~ High Channel

EIRP +30 dBm ~ Low Channel

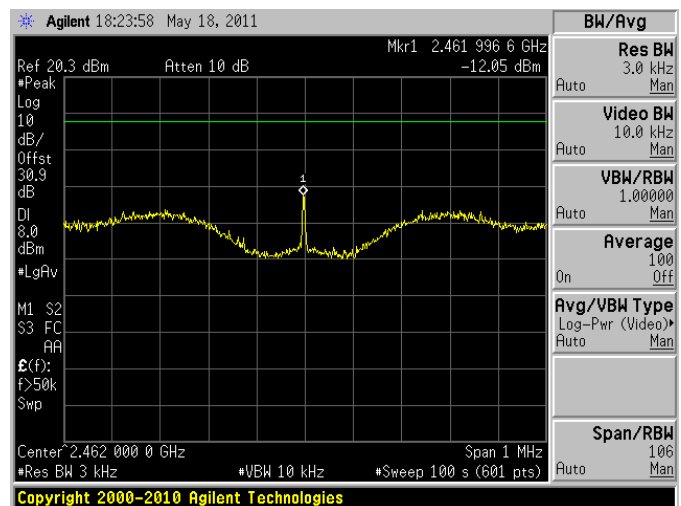
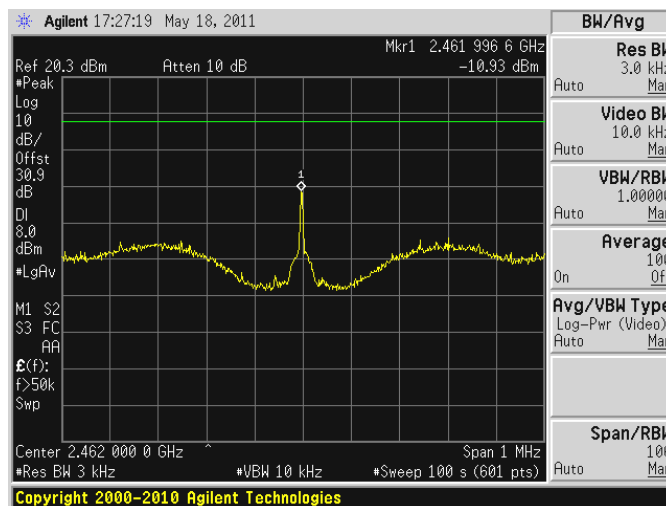



EIRP +30 dBm ~ Middle Channel

EIRP +30 dBm ~ High Channel

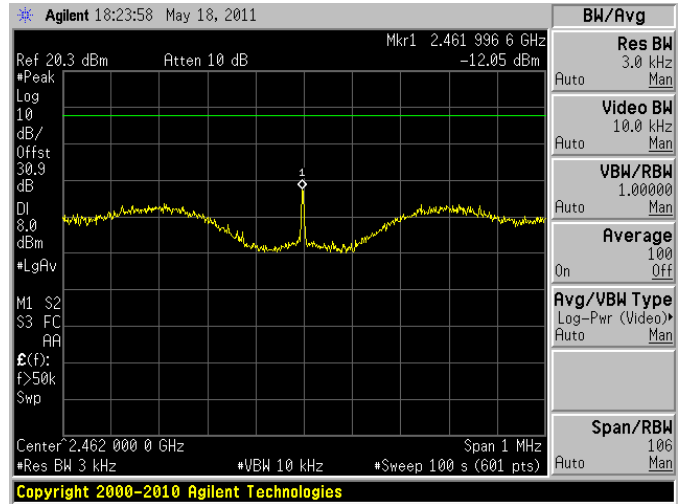
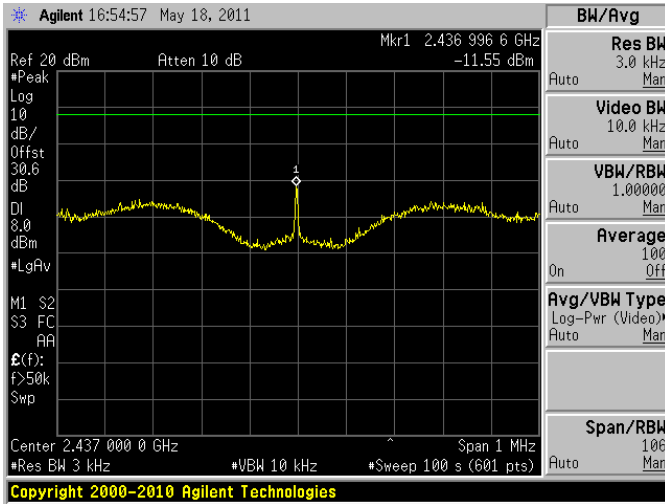

2.4 GHz, Antenna #2:

EIRP +20 dBm ~ Low Channel

EIRP +20 dBm ~ Middle Channel

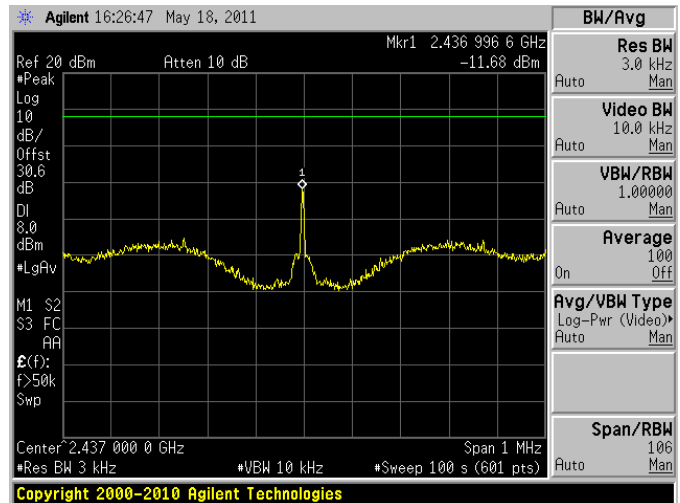
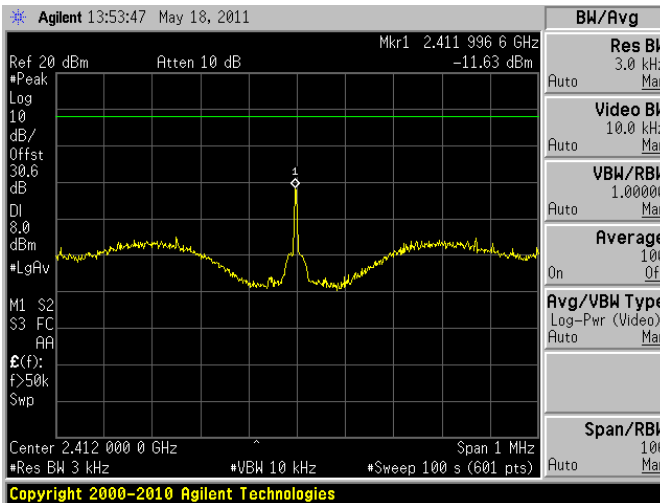

EIRP +20 dBm ~ High Channel

EIRP +30 dBm ~ Low Channel

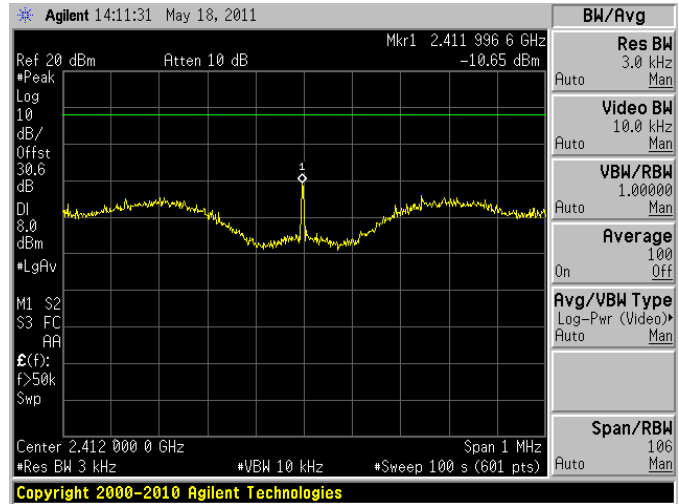
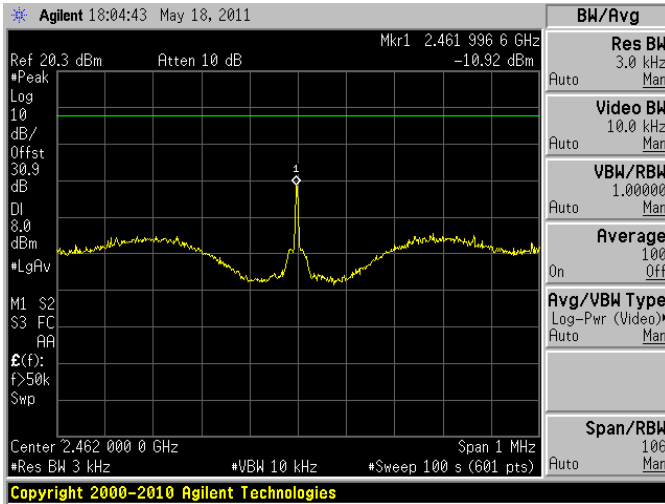

EIRP +30 dBm ~ Middle Channel

EIRP +30 dBm ~ High Channel

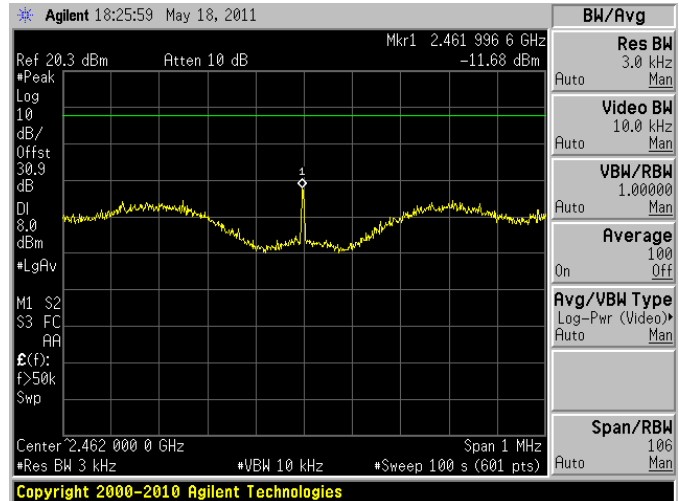
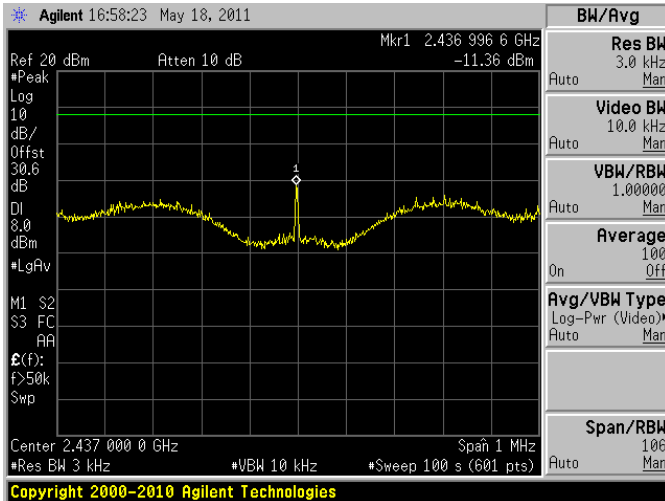

2.4 GHz, Antenna #3:

EIRP +20 dBm ~ Low Channel

EIRP +20 dBm ~ Middle Channel

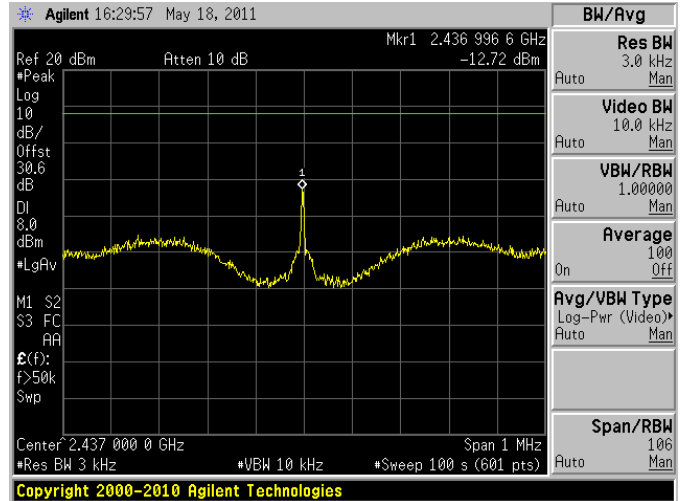
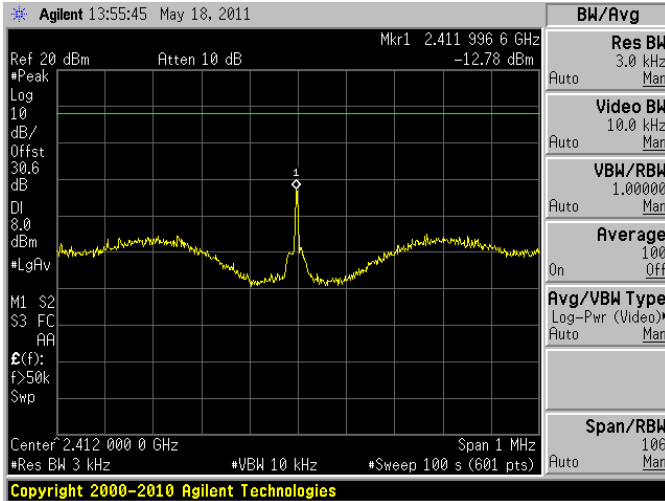

EIRP +20 dBm ~ High Channel

EIRP +30 dBm ~ Low Channel

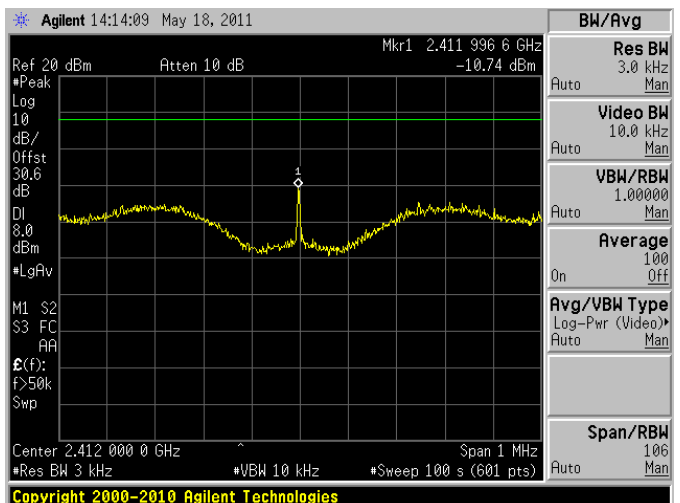
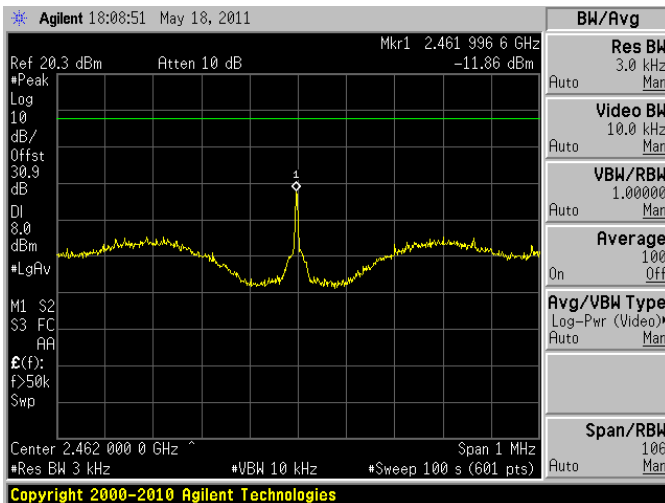

EIRP +30 dBm ~ Middle Channel

EIRP +30 dBm ~ High Channel

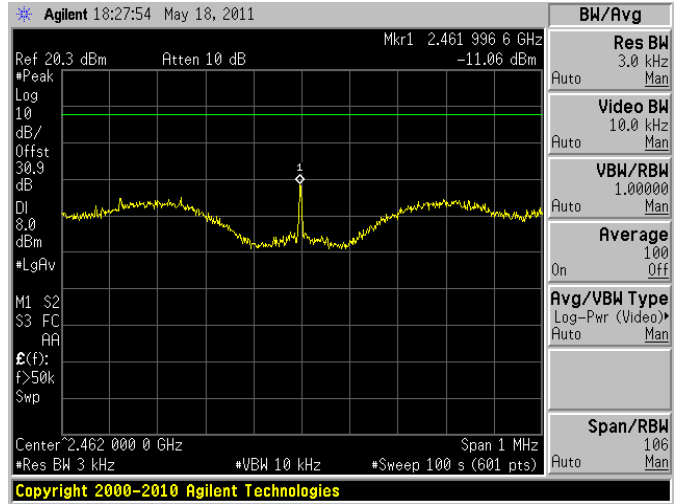
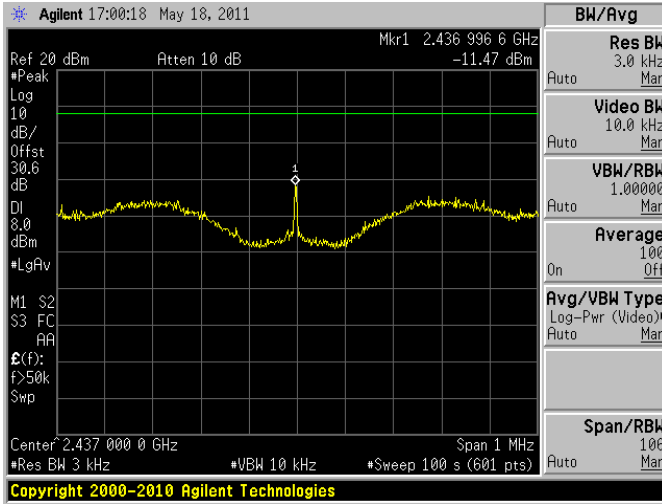

2.4 GHz, Antenna #4:

EIRP +20 dBm ~ Low Channel

EIRP +20 dBm ~ Middle Channel

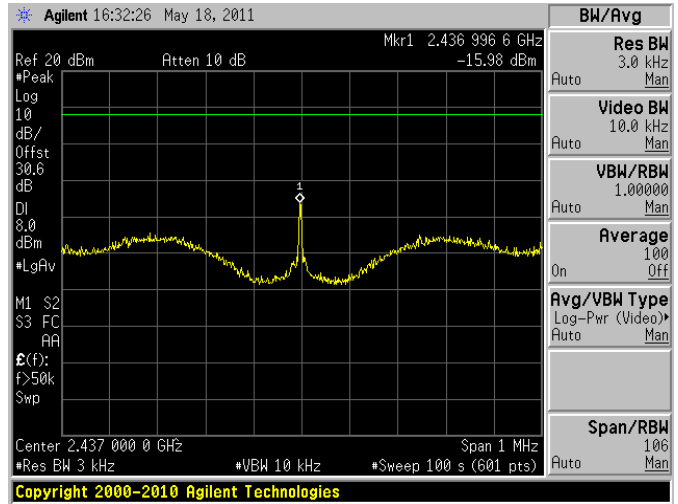
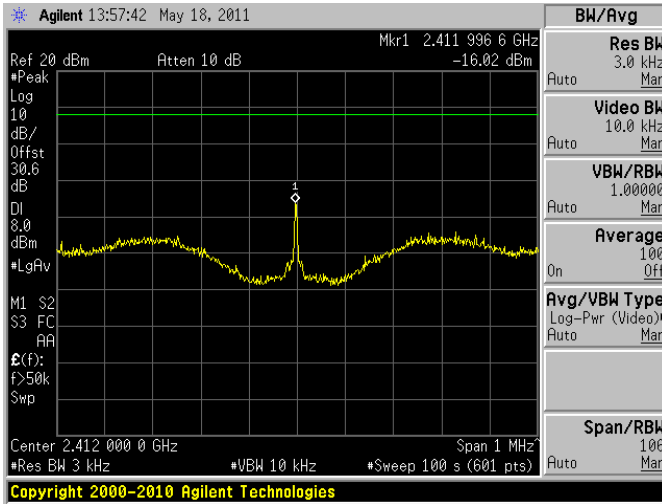

EIRP +20 dBm ~ High Channel

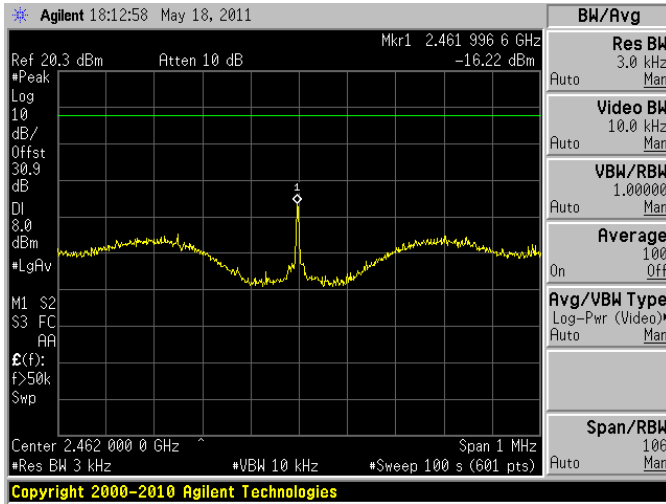

EIRP +30 dBm ~ Low Channel

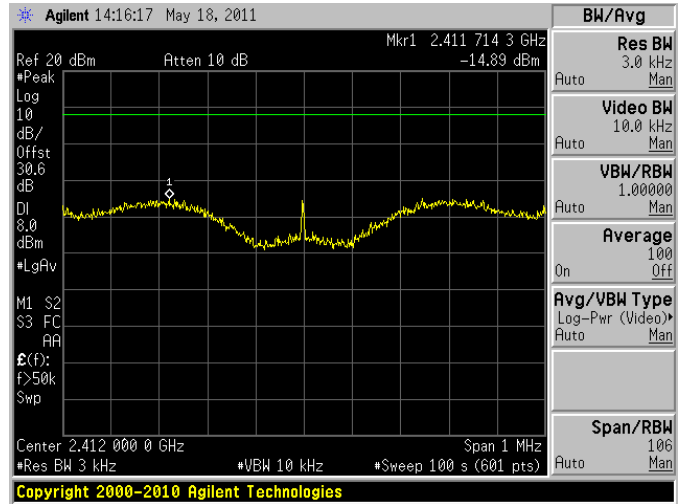

EIRP +30 dBm ~ Middle Channel

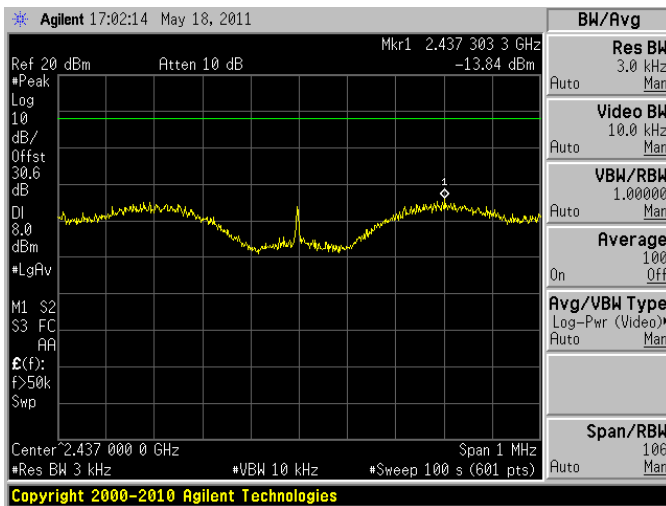

EIRP +30 dBm ~ High Channel

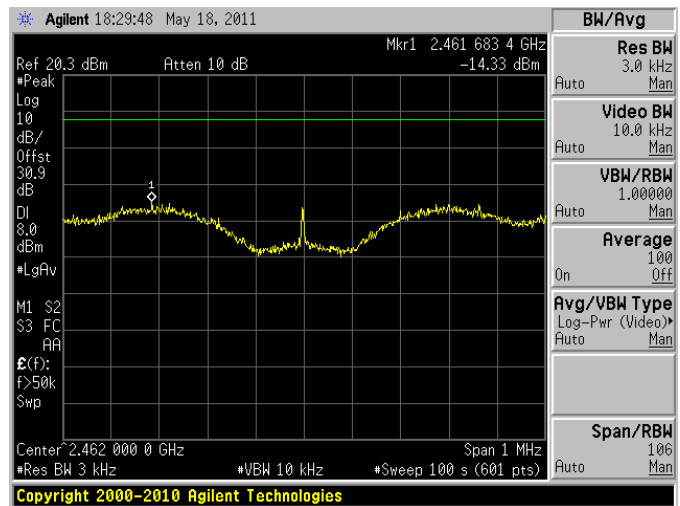

**5.8 GHz Band (5745-5825 MHz): BPSK with 5 MHz bandwidth**

**5.8 GHz, Antenna #1:**

EIRP +30 dBm ~ Low Channel

EIRP +30 dBm ~ Middle Channel

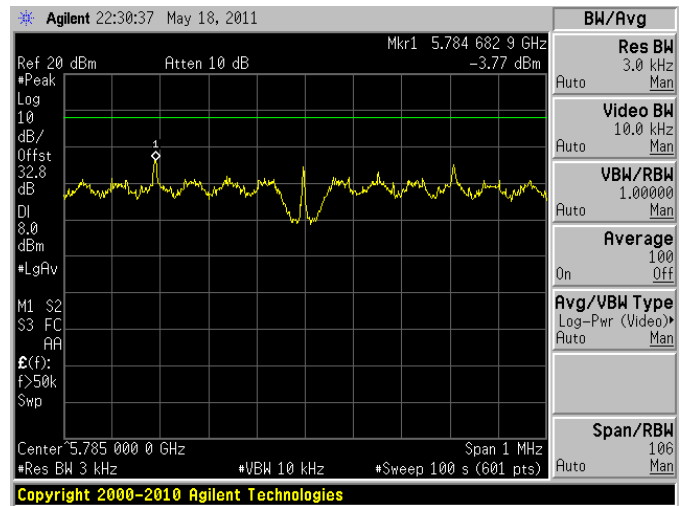
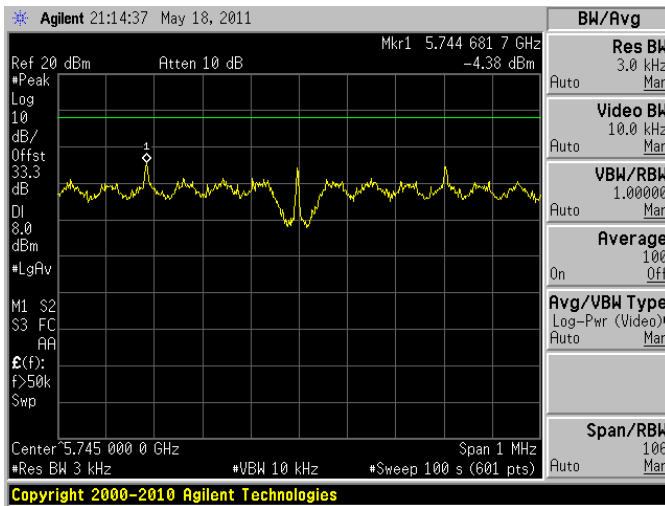

EIRP +30 dBm ~ High Channel

EIRP +36 dBm ~ Low Channel

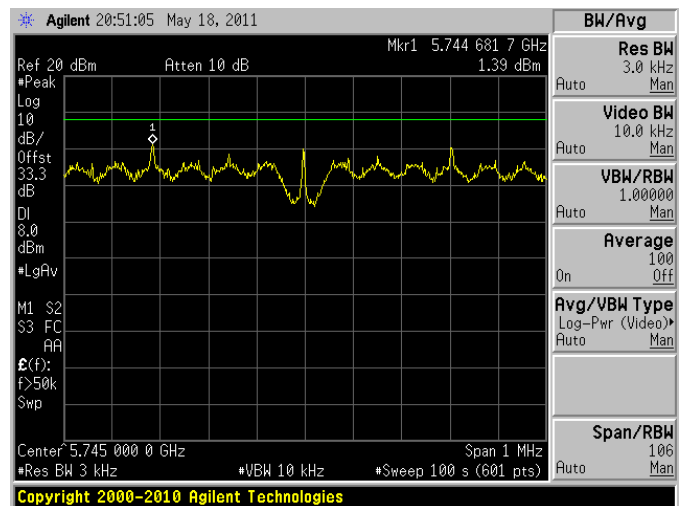
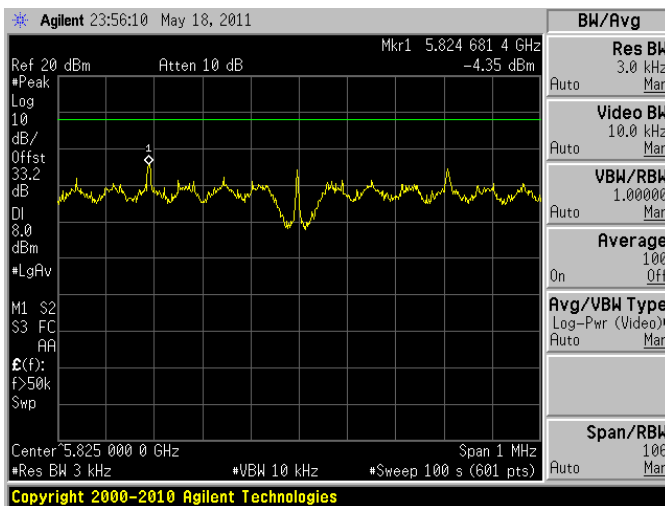

EIRP +36 dBm ~ Middle Channel

EIRP +36 dBm ~ High Channel

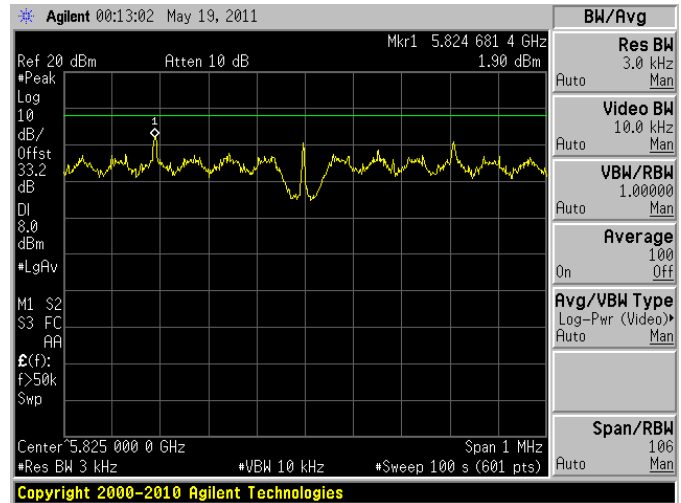
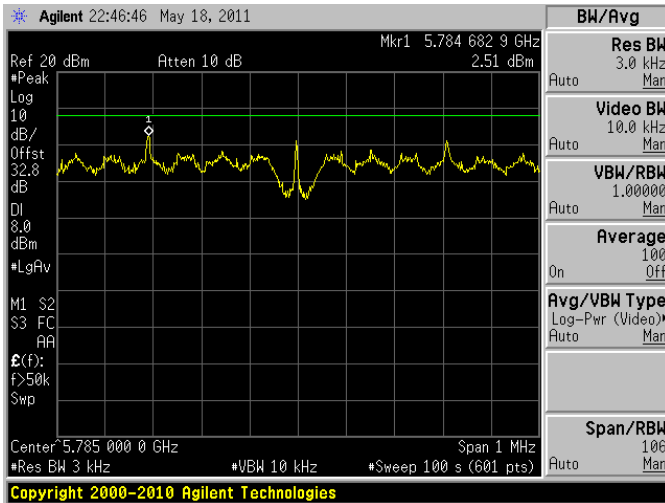

5.8 GHz, Antenna #2:

EIRP +30 dBm ~ Low Channel

EIRP +30 dBm ~ Middle Channel

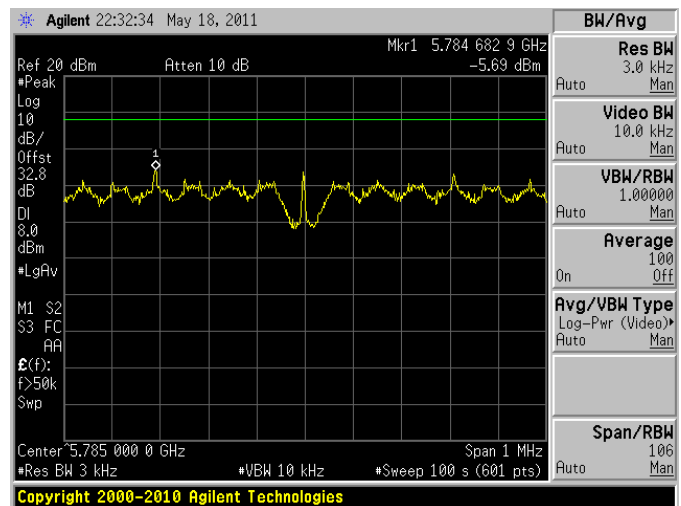
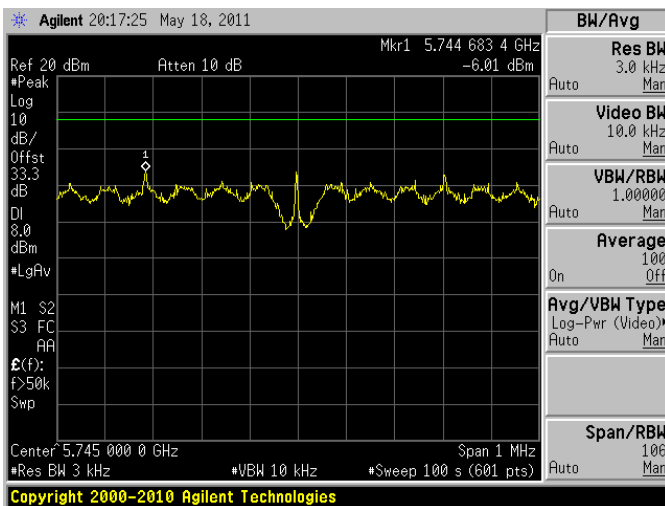

EIRP +30 dBm ~ High Channel

EIRP +36 dBm ~ Low Channel

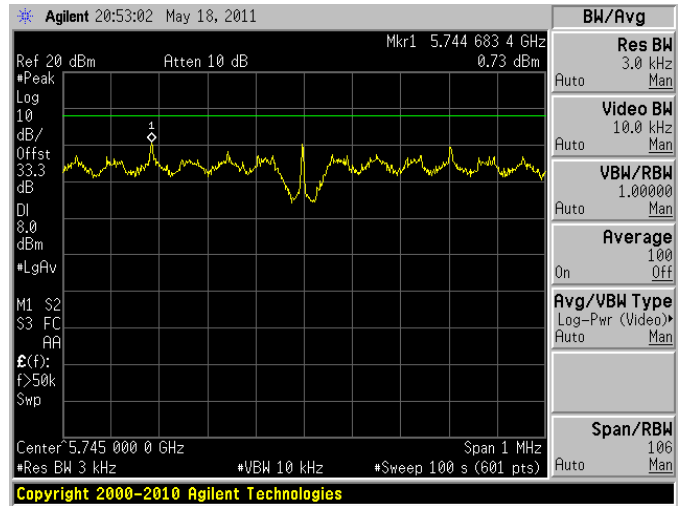
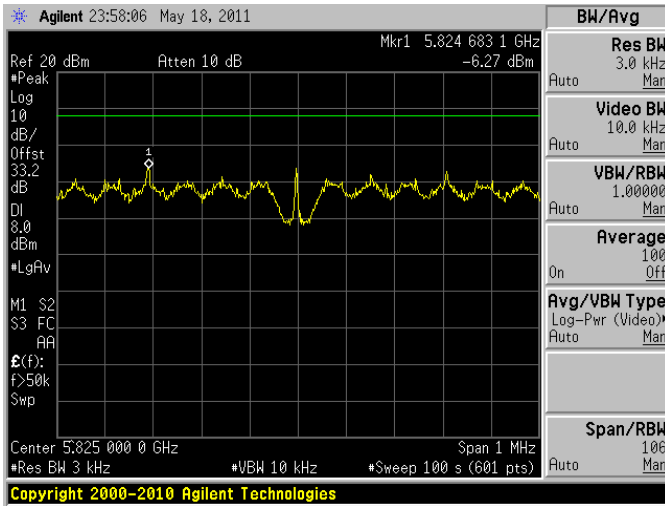

EIRP +36 dBm ~ Middle Channel

EIRP +36 dBm ~ High Channel

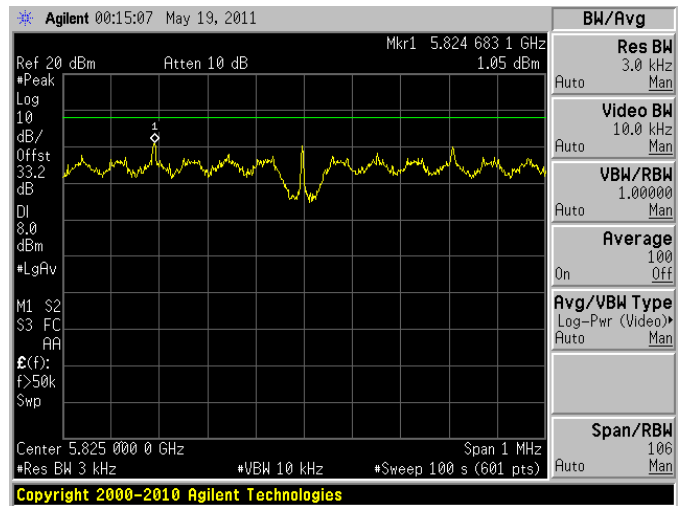
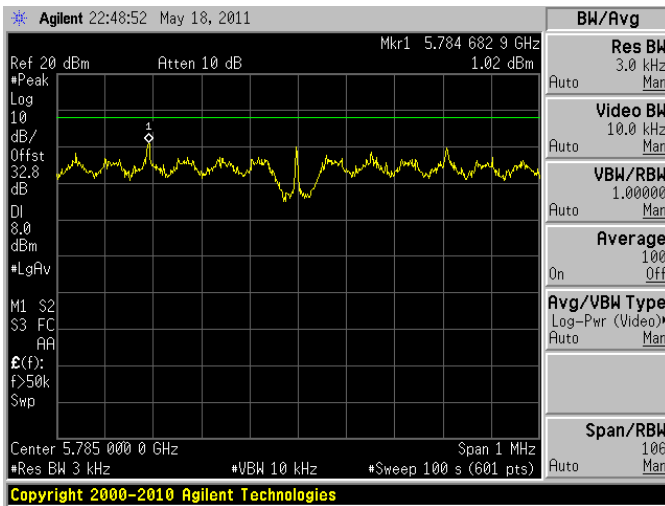



5.8 GHz, Antenna #3:

EIRP +30 dBm ~ Low Channel

EIRP +30 dBm ~ Middle Channel

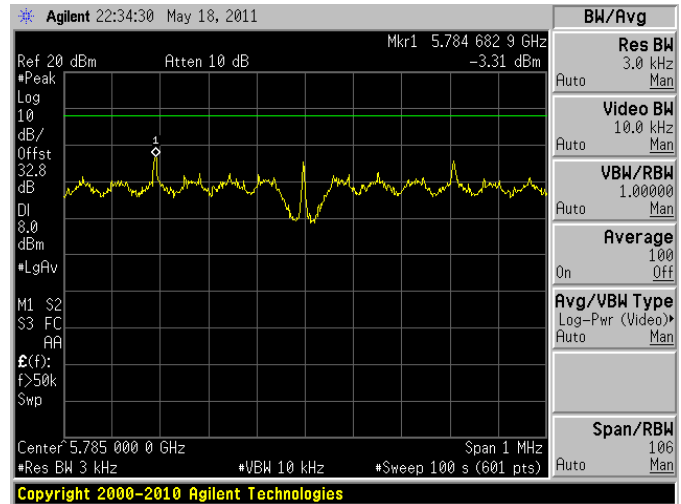
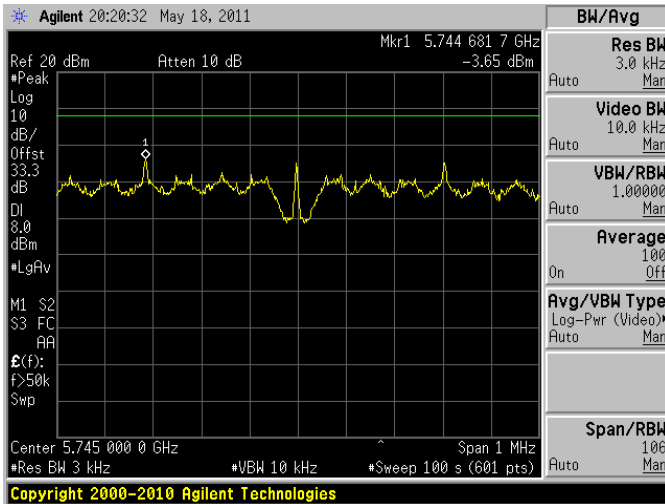

EIRP +30 dBm ~ High Channel

EIRP +36 dBm ~ Low Channel

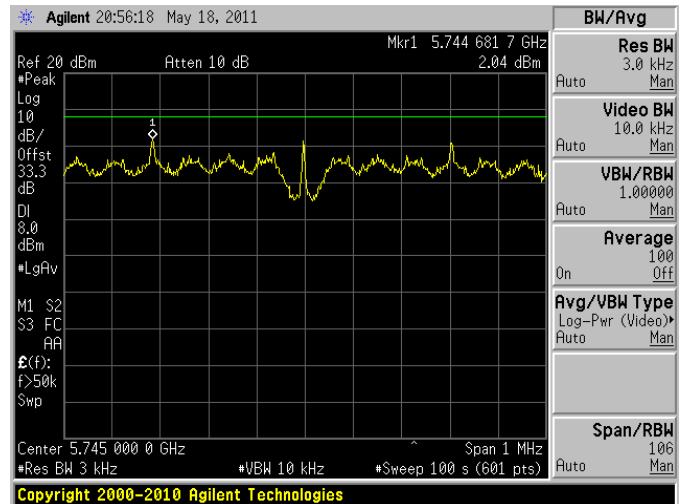
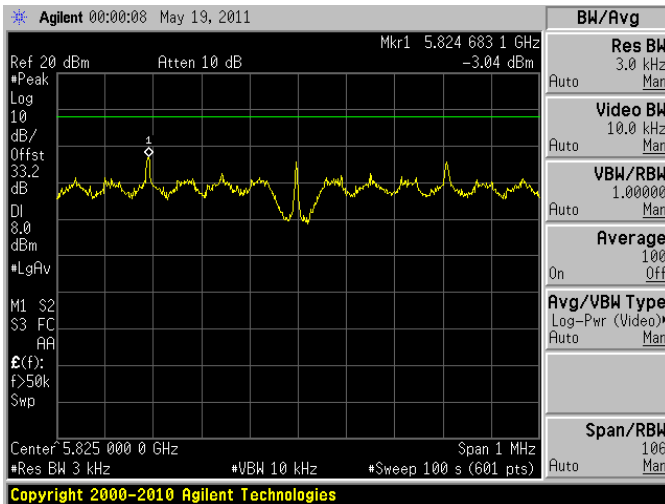

EIRP +36 dBm ~ Middle Channel

EIRP +36 dBm ~ High Channel

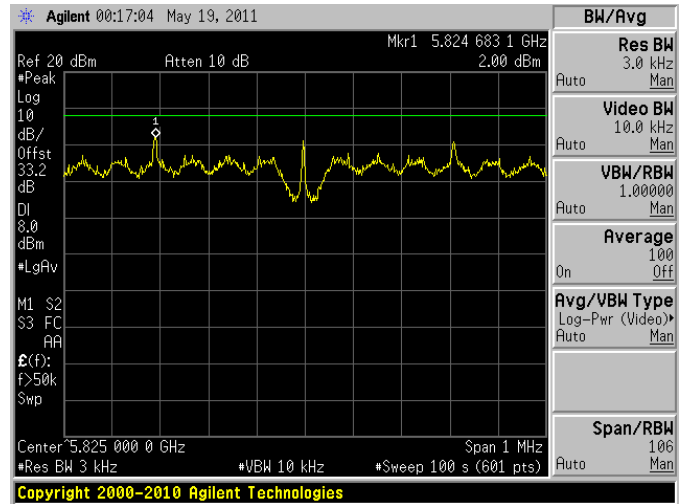
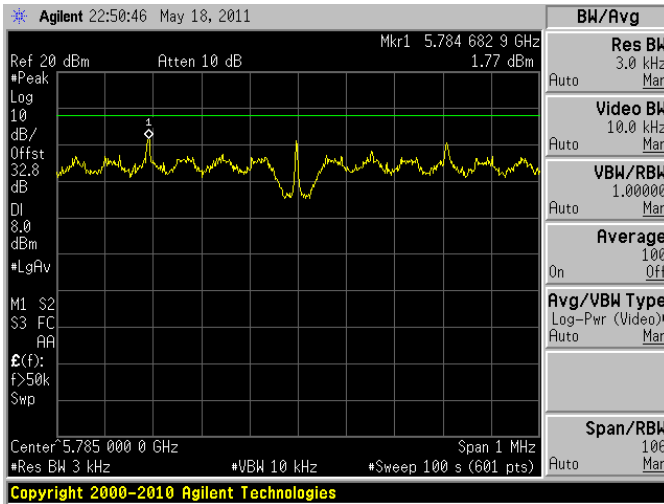

5.8 GHz, Antenna #4:

EIRP +30 dBm ~ Low Channel

EIRP +30 dBm ~ Middle Channel

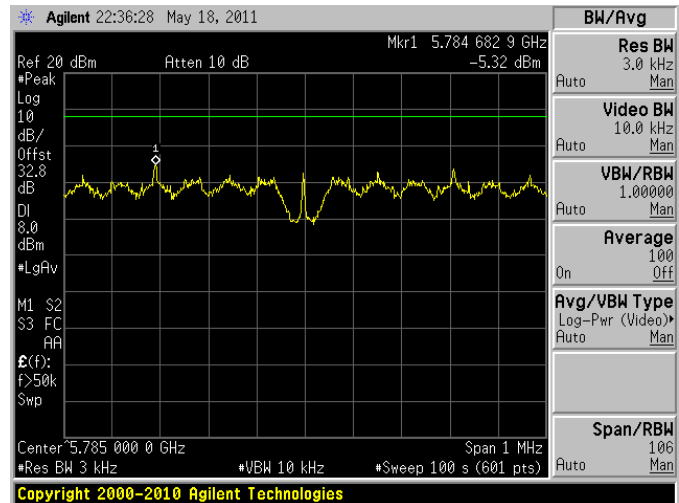
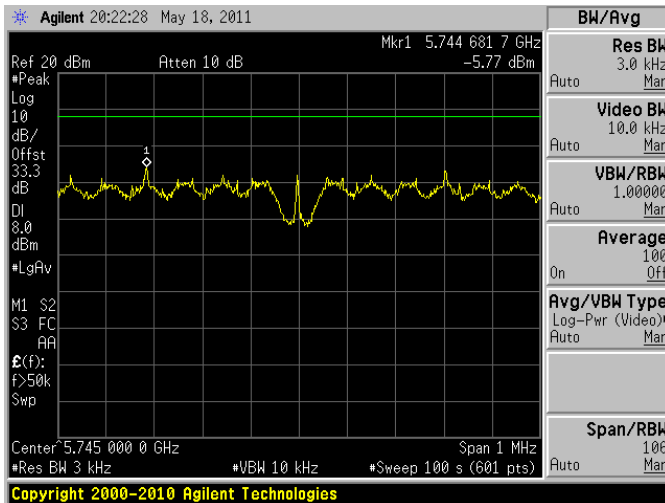

EIRP +30 dBm ~ High Channel

EIRP +36 dBm ~ Low Channel

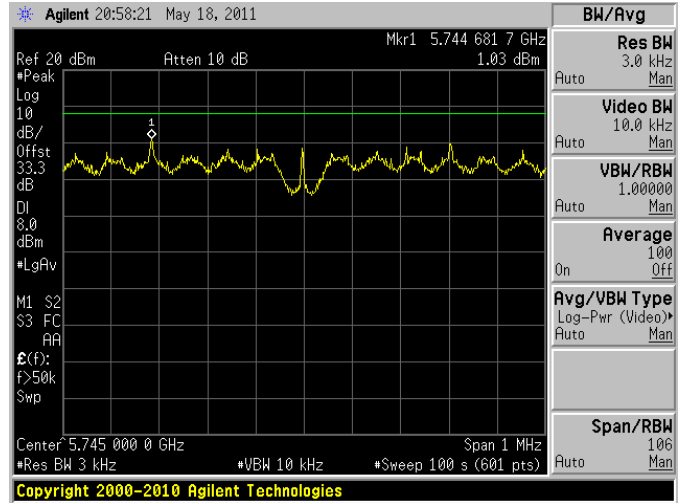
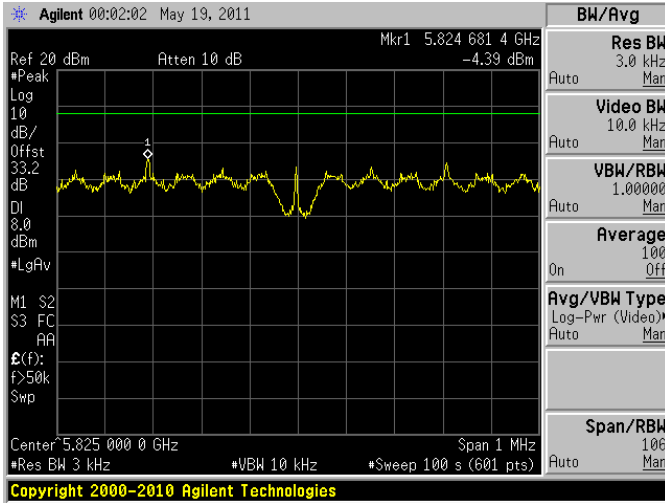

EIRP +36 dBm ~ Middle Channel

EIRP +36 dBm ~ High Channel

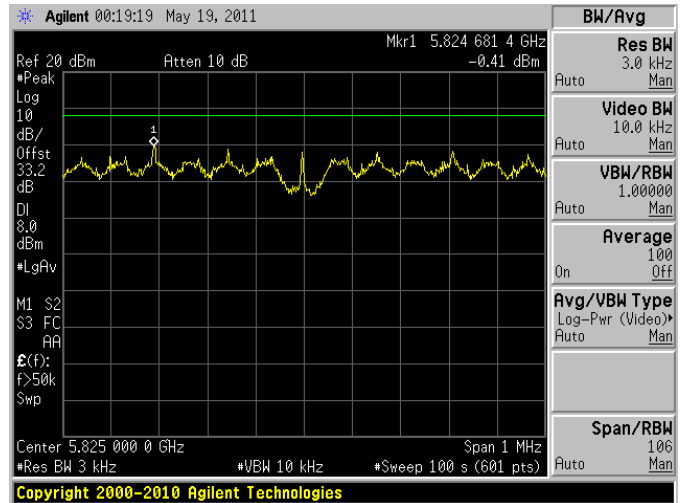
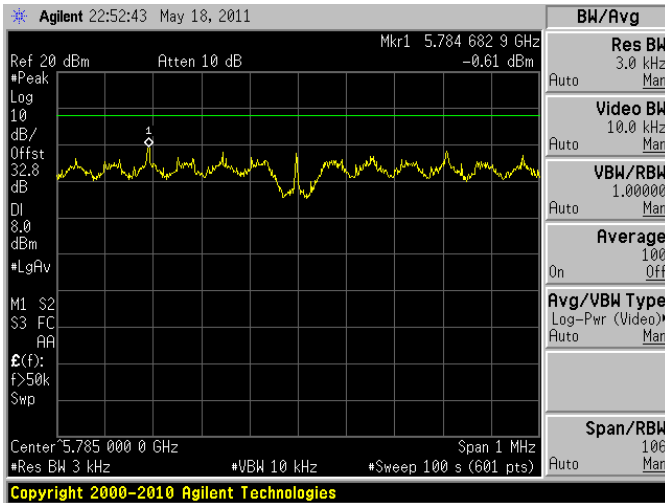

**5.8 GHz Band (5745-5825MHz): BPSK with 20 MHz bandwidth**

**5.8 GHz, Antenna #1:**

EIRP +30 dBm ~ Low Channel

EIRP +30 dBm ~ Middle Channel

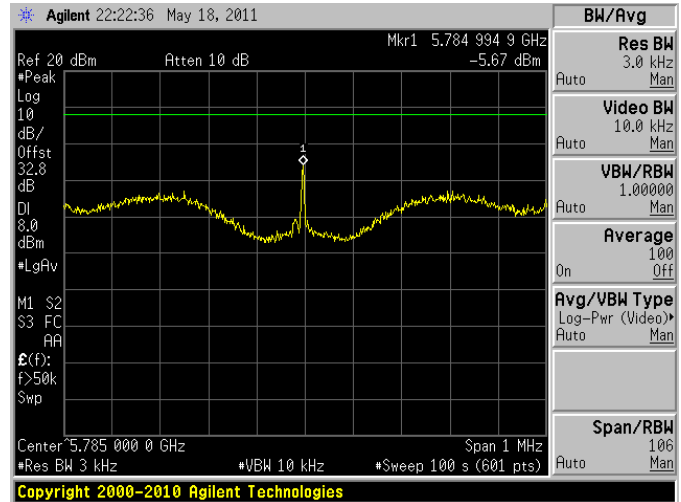
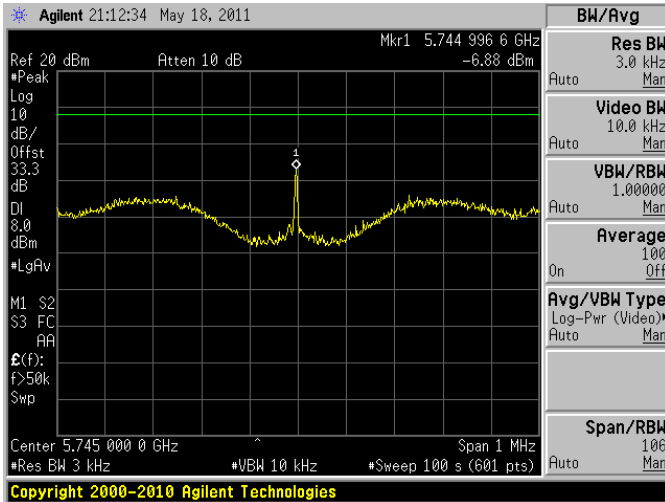

EIRP +30 dBm ~ High Channel

EIRP +36 dBm ~ Low Channel

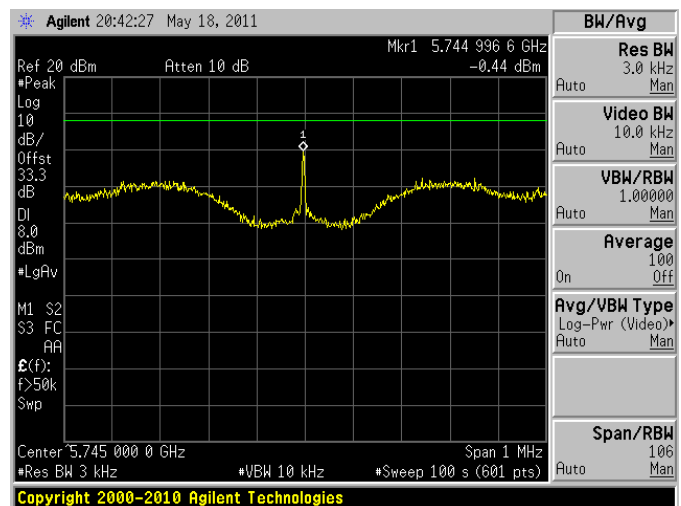
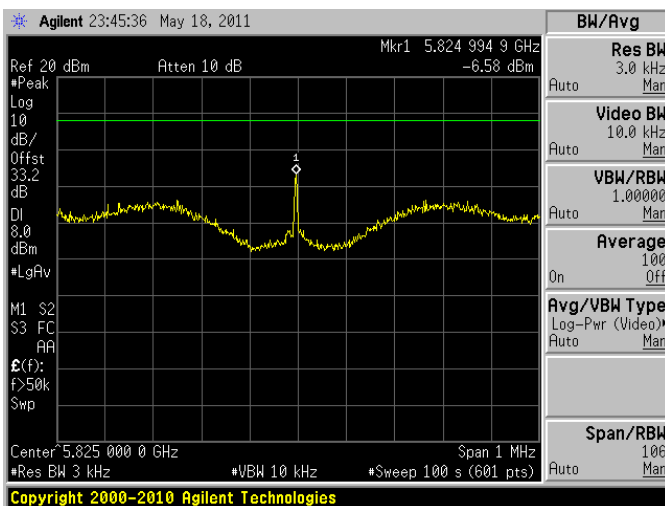

EIRP +36 dBm ~ Middle Channel

EIRP +36 dBm ~ High Channel

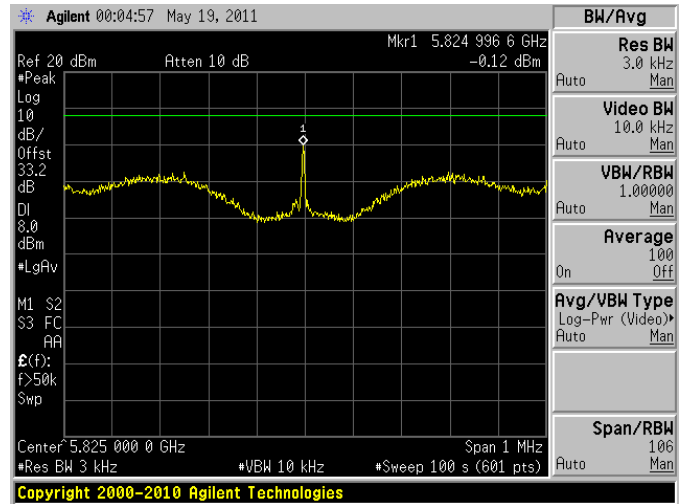
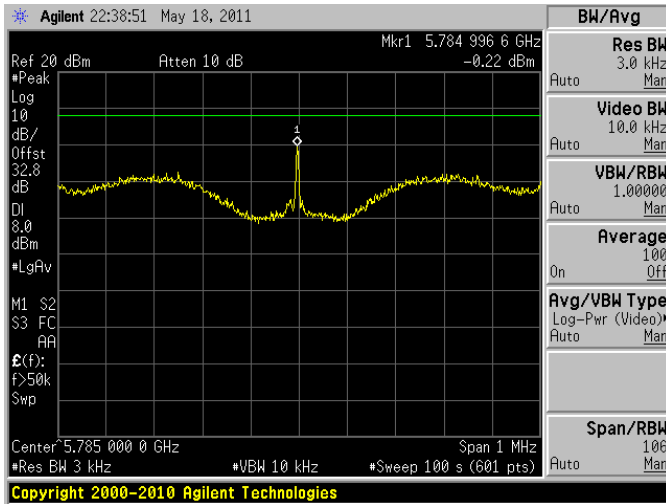

5.8 GHz, Antenna #2:

EIRP +30 dBm ~ Low Channel

EIRP +30 dBm ~ Middle Channel

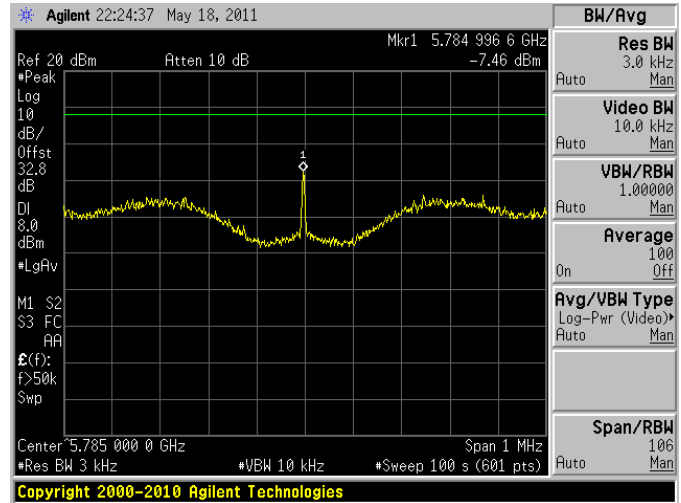
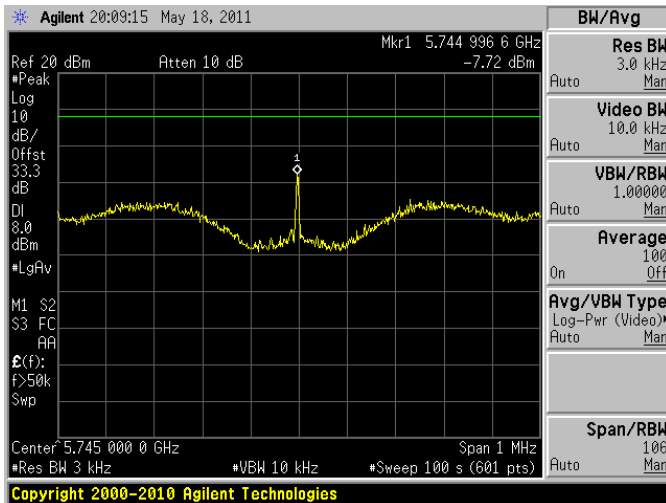

EIRP +30 dBm ~ High Channel

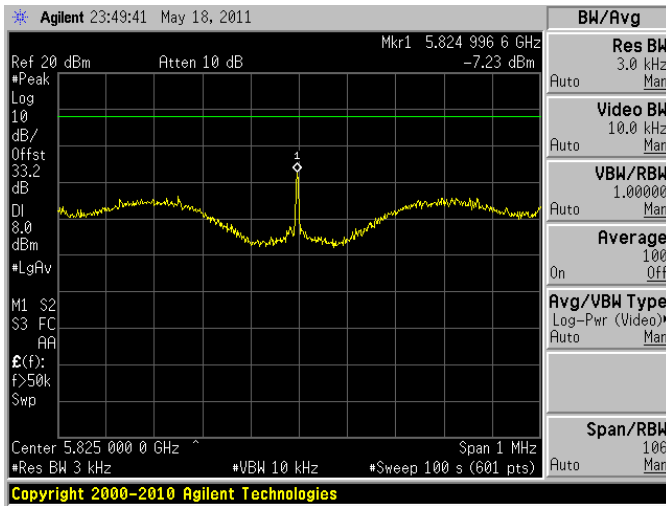

EIRP +36 dBm ~ Low Channel

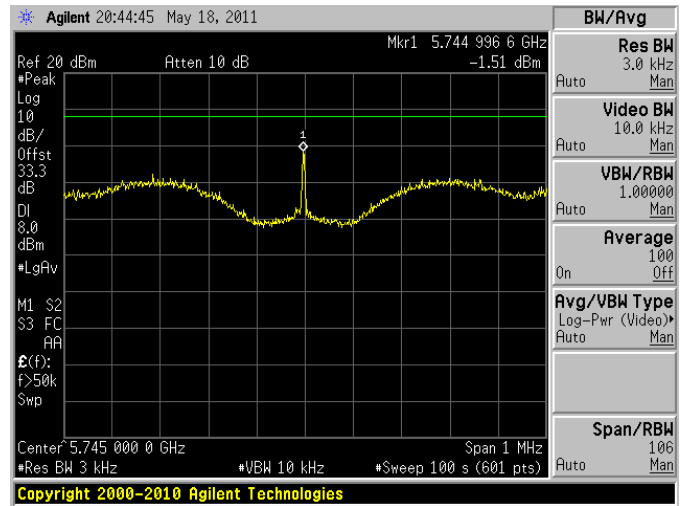

EIRP +36 dBm ~ Middle Channel

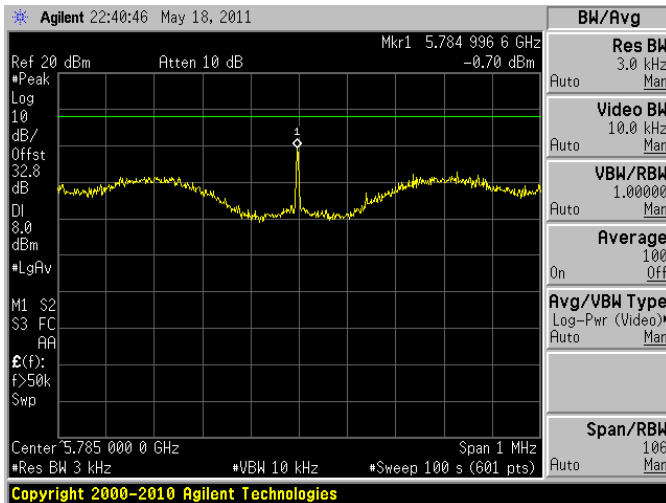

EIRP +36 dBm ~ High Channel

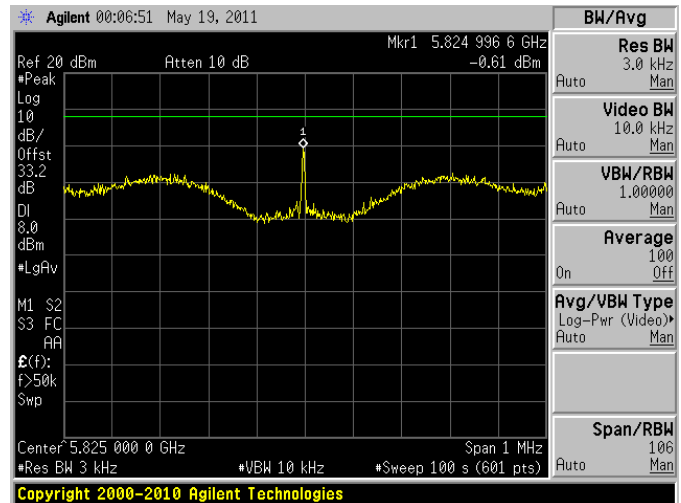

5.8 GHz, Antenna #3:

EIRP +30 dBm ~ Low Channel

EIRP +30 dBm ~ Middle Channel

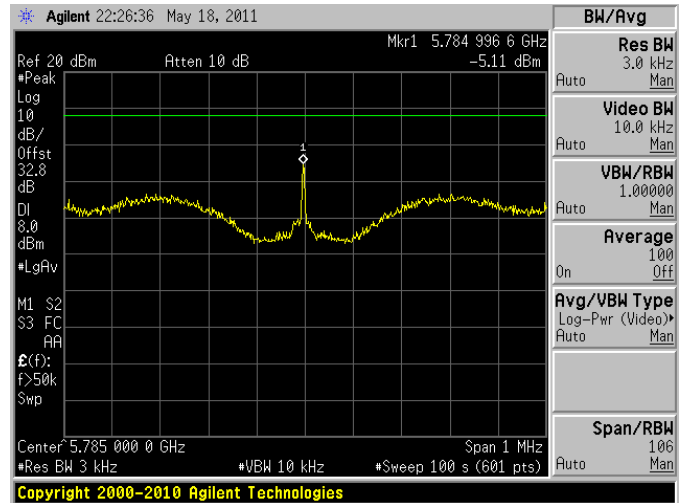
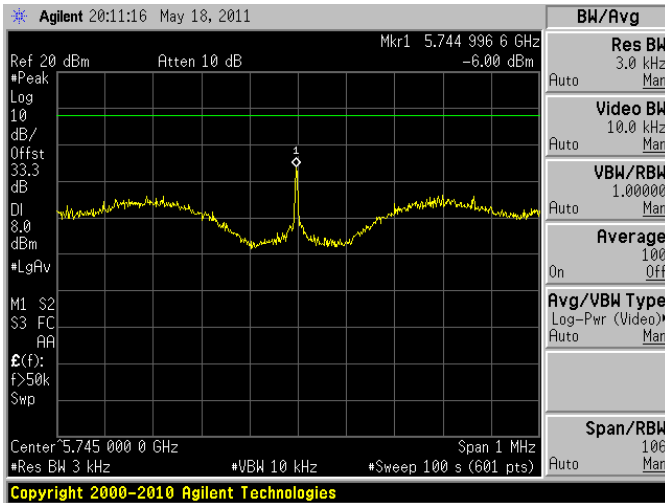

EIRP +30 dBm ~ High Channel

EIRP +36 dBm ~ Low Channel

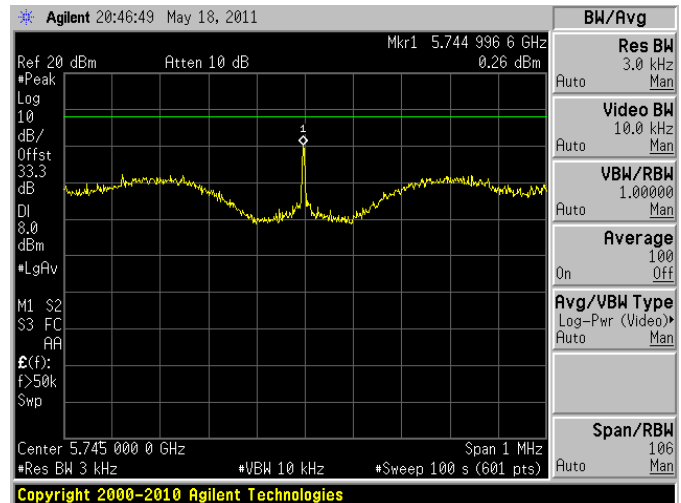
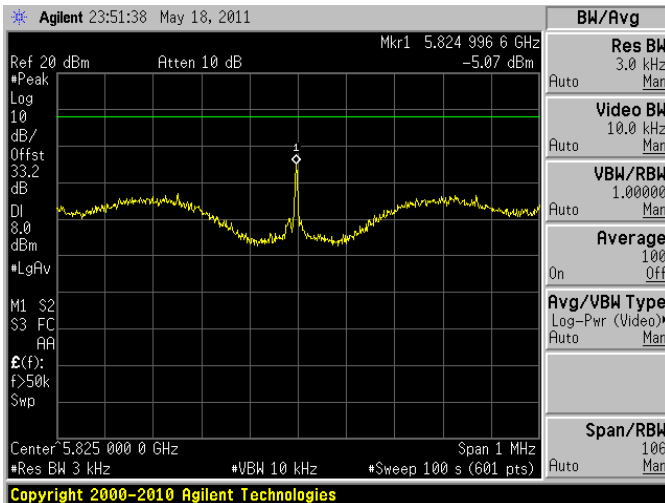

EIRP +36 dBm ~ Middle Channel

EIRP +36 dBm ~ High Channel

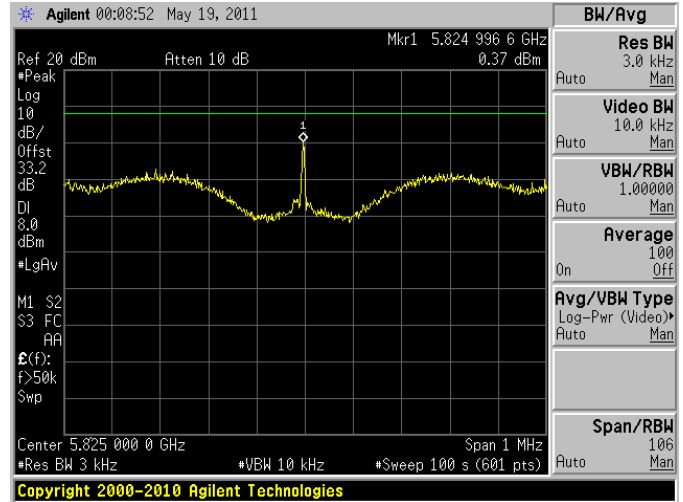
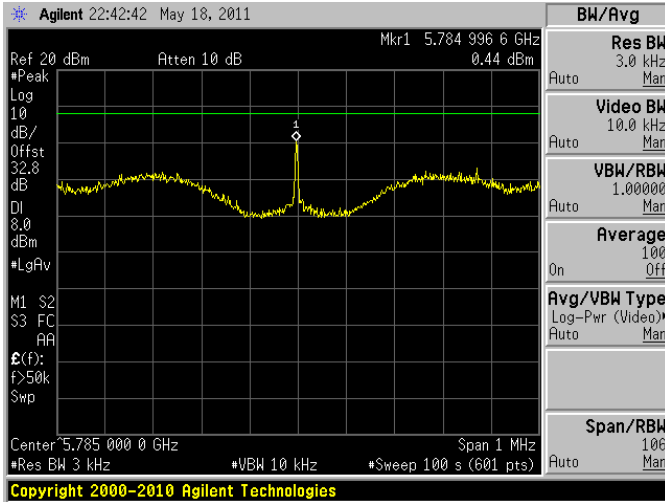

5.8 GHz, Antenna #4:

EIRP +30 dBm ~ Low Channel

EIRP +30 dBm ~ Middle Channel

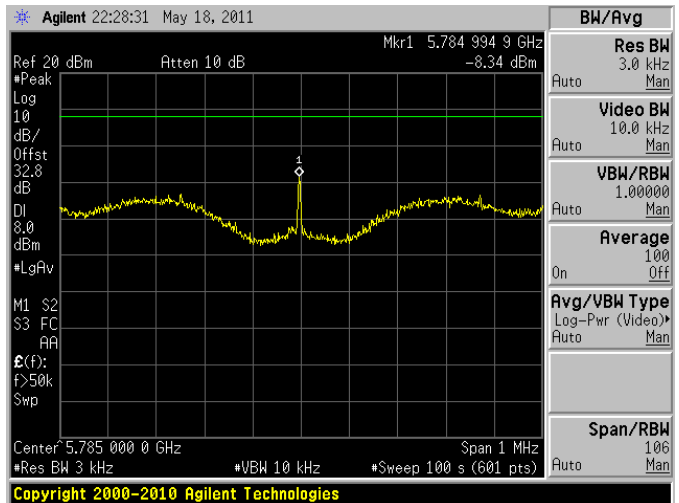
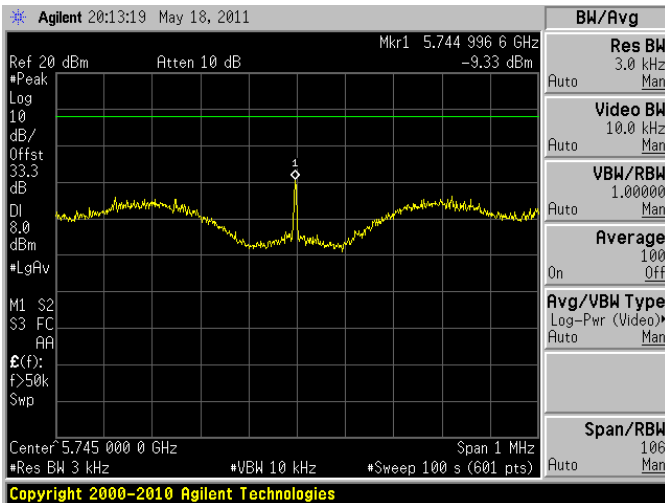



EIRP +30 dBm ~ High Channel

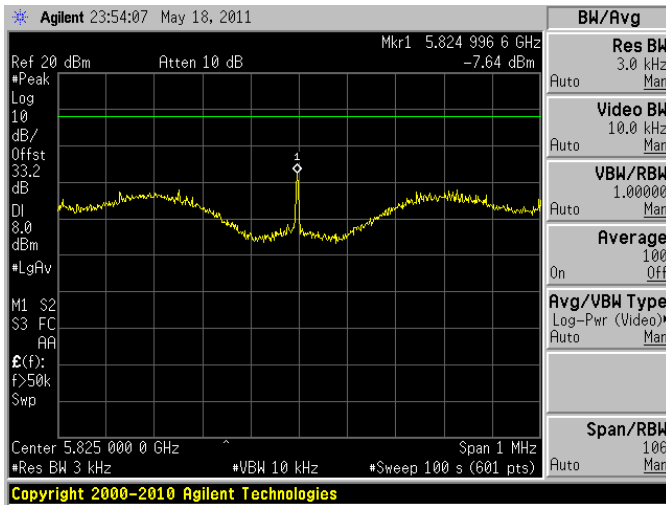

EIRP +36 dBm ~ Low Channel

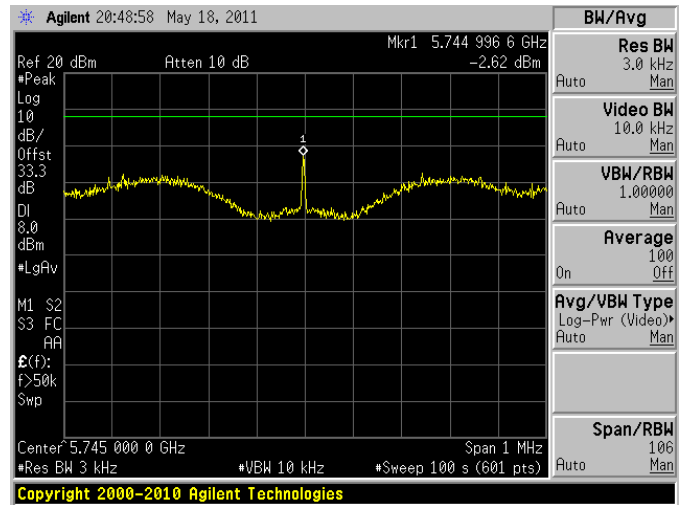

EIRP +36 dBm ~ Middle Channel

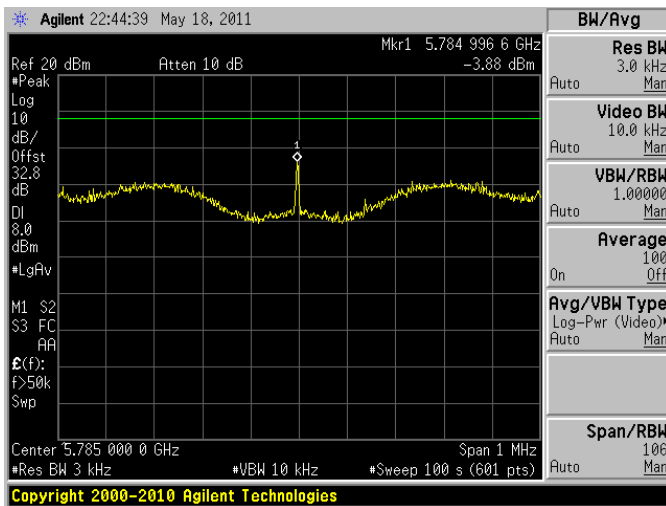

EIRP +36 dBm ~ High Channel

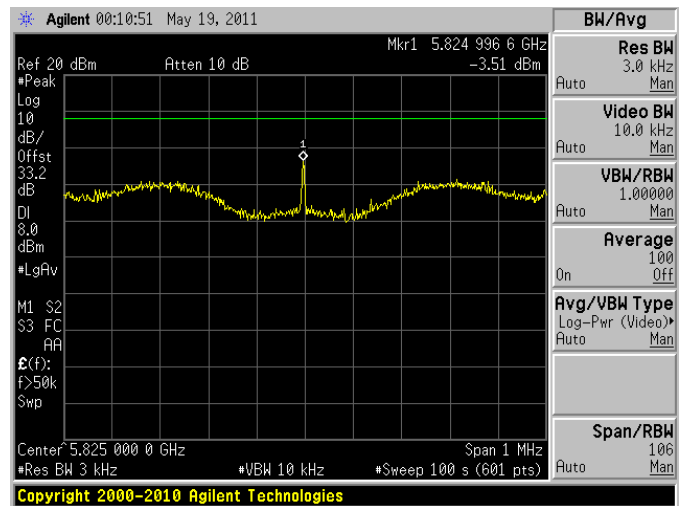

## 13 IC RSS-Gen §4.10 & §6 - Receiver Spurious Radiated Emissions

### 13.1 Applicable Standard

According to IC RSS-Gen §4.10, the receiver shall be operated in the normal receive mode near the mid-point of the band over which the receiver is designed to operate.

Unless otherwise specified in the applicable RSS, the radiated emission measurement is the standard measurement method (with the device's antenna in place) to measure receiver spurious emissions.

Radiated emission measurements are to be performed using a calibrated open-area test site.

For either method, the search for spurious emissions shall be from the lowest frequency internally generated or used in the receiver (e.g. local oscillator, intermediate or carrier frequency), or 30 MHz, whichever is the higher, to at least 3 times the highest tuneable or local oscillator frequency, whichever is the higher, without exceeding 40 GHz.

For emissions below 1 GHz, measurements shall be performed using a CISPR quasi-peak detector and the related measurement bandwidth. As an alternative to CISPR quasi-peak measurement, compliance with the emission limit can be demonstrated using measuring equipment employing a peak detector with the same measurement bandwidth as that for CISPR quasi-peak measurements. Above 1 GHz, measurements shall be performed using an average detector and a resolution bandwidth of 300 kHz to 1 MHz.

According to RSS-210 §6, If a radiated measurement is made, all spurious emissions shall comply with the limits of Table 1. The resolution bandwidth of the spectrum analyzer shall be 100 kHz for spurious emission measurements below 1.0 GHz, and 1.0 MHz for measurements above 1.0 GHz.

Table 1 - Spurious Emission Limits for Receivers

Spurious Frequency (MHz)	Field Strength (microvolt/m at 3 metres)
30-88	100
88-216	150
216-960	200
Above 960	500

### 13.2 EUT Setup

The radiated emissions tests were performed in the 3 meter chamber, using the setup in accordance with ANSI C63.4-2003.

### 13.3 Test Procedure

Maximizing procedure was performed on the six (6) highest emissions to ensure EUT compliance is with all installation combinations.

All data were recorded in the peak detection mode. Quasi-peak readings was performed only when an emissions was found to be marginal (within -4 dB of specification limits), and are distinguished with a "QP" in the data table.

### 13.4 Corrected Amplitude & Margin Calculation

The Corrected Amplitude is calculated by adding the Antenna Factor and Cable Factor, and subtracting the Amplifier Gain from the Amplitude reading. The basic equation is as follows:

$$\text{Corrected Amplitude} = \text{Indicated Reading} + \text{Antenna Factor} + \text{Cable Factor} - \text{Amplifier Gain}$$

The “**Margin**” column of the following data tables indicates the degree of compliance with the applicable limit. For example, a margin of -7 dB means the emission is 7 dB below the maximum limit. The equation for margin calculation is as follows:

$$\text{Margin} = \text{Corrected Amplitude} - \text{Limit}$$

### 13.5 Test Equipment Lists and Details

Manufacturer	Description	Model	Serial Number	Calibration Date
Sunol Science Corp	Combination Antenna	JB1	A020106-1	2010-05-28
Rohde & Schwarz	EMI Test Receiver	ESCI 1166.5950K03	100337	2011-03-21
Sunol Science Corp	System Controller	SC99V	122303-1	N/R
A.R.A Inc	Horn antenna	DRG-1181A	1132	2010-11-29
Agilent	PSA Series Spectrum Analyzer	E4446A	US44300386	2010-08-18
Mini-Circuits	Pre Amplifier	ZVA-183-S	570400946	2011-05-09

**Statement of Traceability:** BACL attests that all calibrations have been performed per the NVLAP requirements, traceable to NIST.

### 13.6 Test Environmental Conditions

<b>Temperature:</b>	18~21 °C
<b>Relative Humidity:</b>	30~35 %
<b>ATM Pressure:</b>	101.2-102.2kPa

*The testing was performed by Jerry Huang on 2011-05-02 ~ 2011-05-10 in 5 meter chamber 3.*

### 13.7 Summary of Test Results

According to the test data., the EUT complied with the with the RSS-210/RSS-Gen, with the closest margins from the limit listed below:

<b>Mode: 2.4 GHz Band (2412–2462 MHz):</b>			
<b>Margin (dB)</b>	<b>Frequency (MHz)</b>	<b>Polarization (Horizontal/Vertical)</b>	<b>Range (MHz)</b>
-2.56	42.57075	Vertical	30 to 1000
-28.74	2461.311	Horizontal	Above 1000

<b>Mode: 5.8 GHz Band (5745–5825 MHz):</b>			
<b>Margin (dB)</b>	<b>Frequency (MHz)</b>	<b>Polarization (Horizontal/Vertical)</b>	<b>Range (MHz)</b>
-0.27	126.25	Vertical	30 to 1000
-16.63	14798.12	Horizontal	Above 1000

### 13.8 Radiated Emission Test Plots and Data

#### (1) Radiated Emission measured at 3 meters - Below 1 GHz

#### 2.4 GHz Band (2412– 2462 MHz)

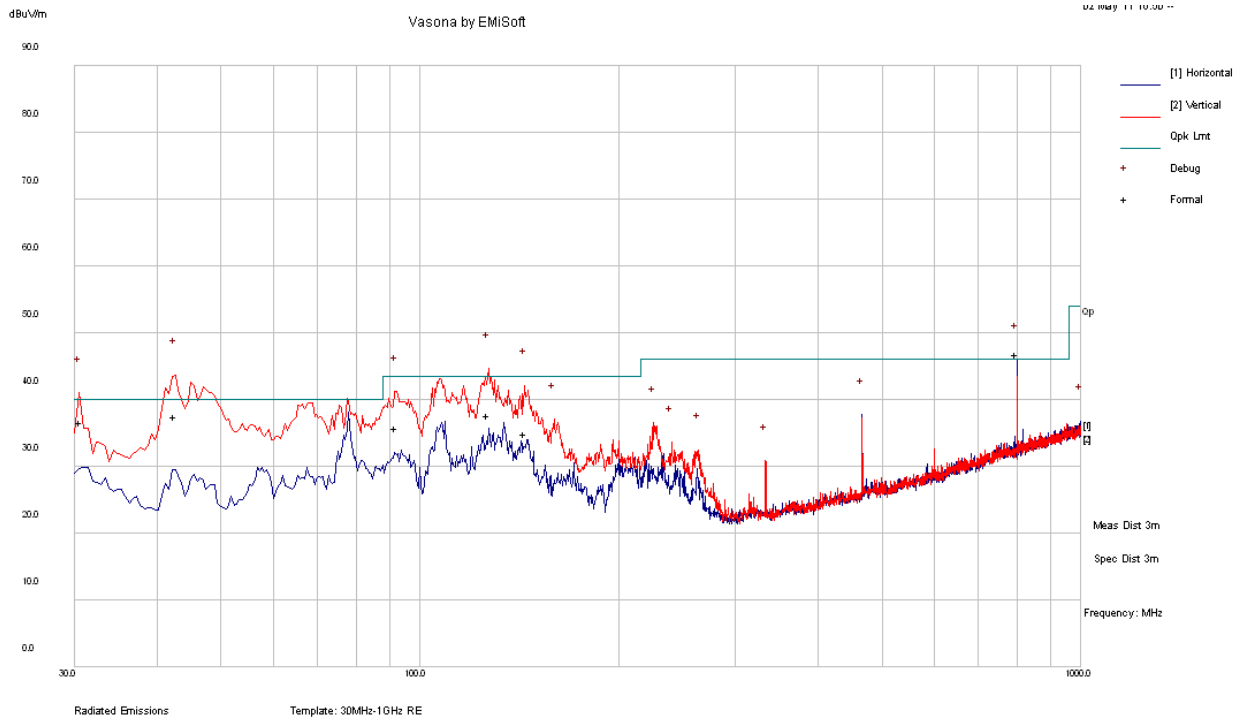

#### Quasi-Peak Measurements

Frequency (MHz)	Corrected Amplitude (dBμV/m)	Antenna Height (cm)	Antenna Polarity (H/V)	Turntable Azimuth (degrees)	Limit (dBμV/m)	Margin (dB)
42.57075	37.44	115	V	82	40	-2.56
30.62625	36.6	144	V	198	40	-3.40
799.971	41.57	203	H	227	46	-4.43
126.7715	37.7	110	V	29	43.5	-5.80
92.05375	35.77	147	V	152	43.5	-7.73
144.0625	34.92	100	V	2	43.5	-8.58

5.8 GHz Band (5745–5825 MHz)

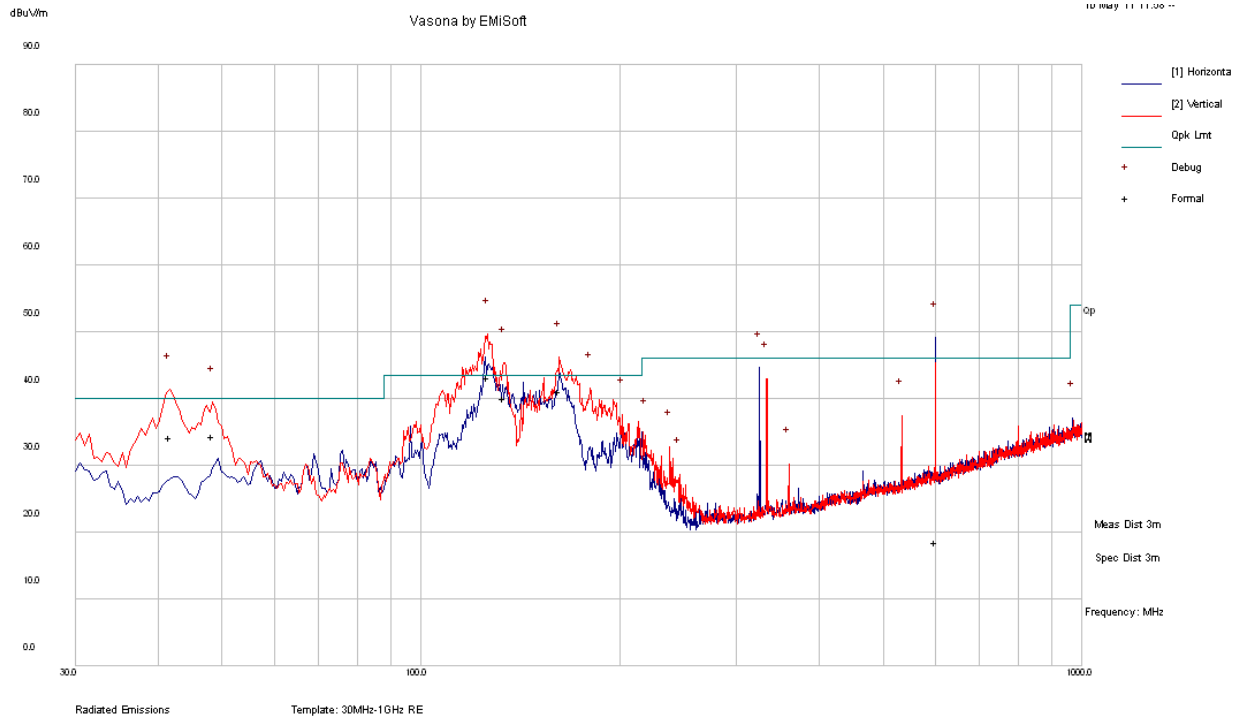

Quasi-Peak Measurements

Frequency (MHz)	Corrected Amplitude (dBμV/m)	Antenna Height (cm)	Antenna Polarity (H/V)	Turntable Azimuth (degrees)	Limit (dBμV/m)	Margin (dB)
126.25	43.23	105	V	281	43.5	-0.27
161.963	41.11	202	V	88	43.5	-2.39
133.6973	40.06	99	V	281	43.5	-3.44
48.40575	34.42	115	V	344	40	-5.58
41.818	34.26	136	V	121	40	-5.74
600.1545	18.51	137	H	74	46	-27.49

**(2) Radiated Emission measured at 3 meters - Above 1 GHz**

2.4 GHz Band (2412–2462 MHz)

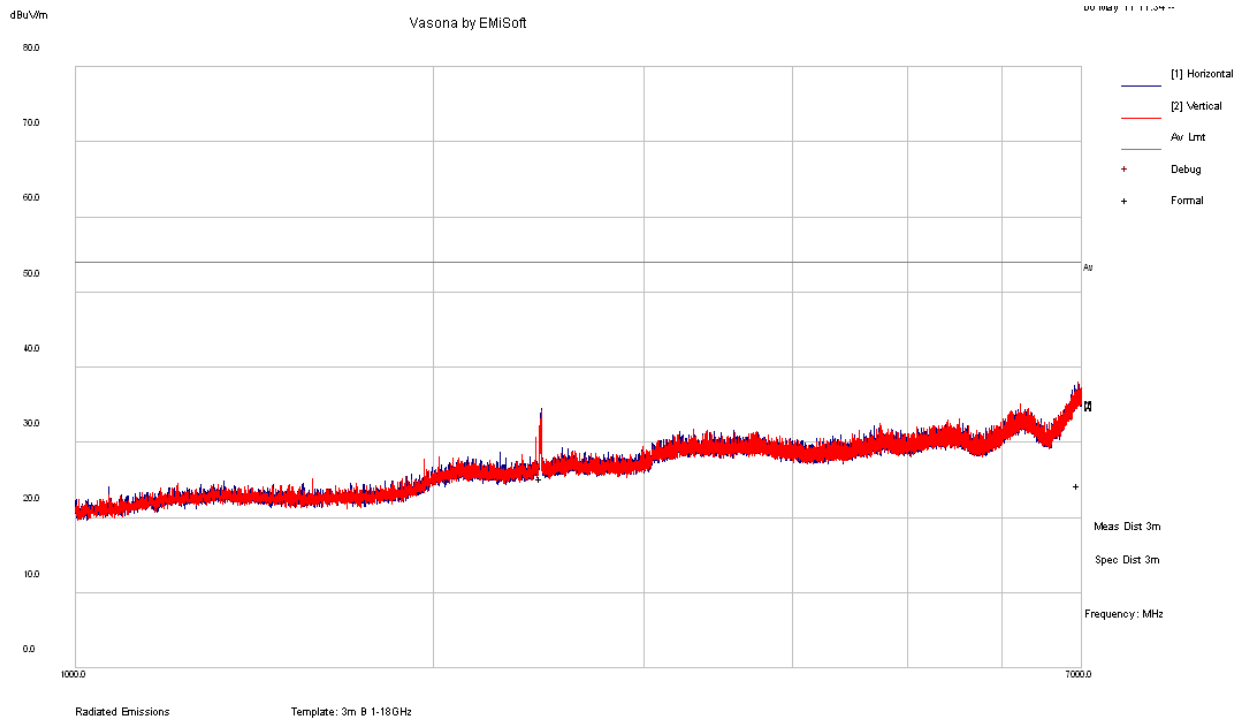

**Average Measurements**

Frequency (MHz)	Corrected Amplitude (dBμV/m)	Antenna Height (cm)	Antenna Polarity (H/V)	Turntable Azimuth (degrees)	Limit (dBμV/m)	Margin (dB)
2461.311	25.26	203	H	230	54	-28.74
6945.656	24.37	189	V	321	54	-29.63

5.8 GHz Band (5745–5825 MHz)

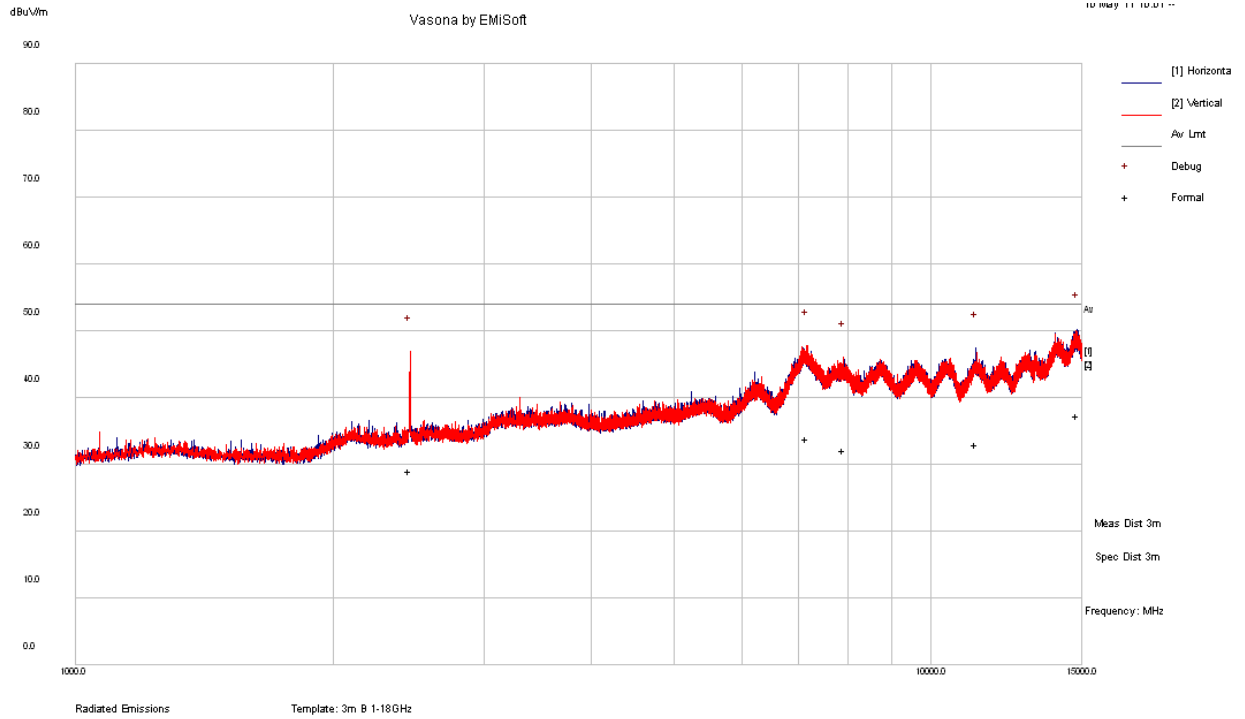

Average Measurements

Frequency (MHz)	Corrected Amplitude (dB $\mu$ V/m)	Antenna Height (cm)	Antenna Polarity (H/V)	Turntable Azimuth (degrees)	Limit (dB $\mu$ V/m)	Margin (dB)
14798.12	37.37	188	H	54	54	-16.63
7147.028	33.85	262	V	72	54	-20.15
11271.71	32.97	130	H	297	54	-21.03
7889.718	32.12	202	V	360	54	-21.88
2458.979	29.05	115	V	28	54	-24.95