

Installation and User Manual

A060-Mini®
Revision B



1 INTRODUCTION		
1.1 Intended users		
1.2 Revision		
1.3 Prior knowledge		
1.4 Warranty		
1.5 Copyright / Disclaimer		
2 SYSTEM OVERVIEW		
2.1 General description		
2.1.1 Benefits		
2.1.2 Applications		
2.2 Package contents		
2.3 System components		
2.3.1 Terminals		
2.3.2 Alignment bracket		
2.3.3 Alignment tool		
2.3.4 Ice bridge		
2.3.5 Accessories		
2.3.5.1 PoE+ injector (accessory)		
2.3.5.2 Mast bracket (accessory)		
3 SITE PLANNING		
3.1 Terminal location		
3.2 Line of sight		
3.3 Link distance / Link availability		
3.4 TERMINAL MOUNTING OPTIONS		
3.4.1 Wall mounting		
3.4.2 Pole mounting		
3.5 Cabling		
3.6 Grounding / Lightning protection		
3.7 Co-located applications		
4 INSTALLATION		
4.1 Mount installation		
4.1.1 Wall mount		
4.1.2 Mast mount		
4.2 Terminal installation		
4.3 Cable installation		
4.4 Antenna alignment		
	4.4.1 Alignment Procedure	1
	4.4.1.1 Optical alignment	1
	4.4.1.2 Power level alignment	1
	4.5 Grounding	1
	4.6 Lightning / Surge protector	1
	4.7 Power injector	1
	5 TERMINAL MANAGEMENT AND MONITORING FUNCTIONS	1
	5.1 Web browser interface	1
	5.1.1 Overview	1
	5.1.2 Wireless	1
	5.1.3 Network	1
	5.1.4 System	1
	5.1.5 Status	1
	5.4 SNMP interface	1
	A TECHNICAL INFORMATION	1
	A.1 Troubleshooting	1
	A.1.1 Power and network connection	1
	A.1.2 Network configuration	1
	A.1.3 Duplex mismatch	1
	A.1.4 Miss-alignment	1
	A.2 Specifications	1
	A.2 Availability / Rain Zone / Link Distance	1
	A.w Map Of America	1
	A.x Map of Asia and Middle East	1
	A.y Map of Europe	1
	C CONTACTS	1
	C.1 Technical assistance	1
	C.1.2 Service center / RMA	1

1 INTRODUCTION

1.1 Intended users

This manual is intended for all installation and service personnel who are involved in the planning, installation, operation and maintenance of the A060-Mini® equipment. Although the A060-Mini® link is designed for easy installation and setup, optimum performance can be achieved by following the procedures outlined in this manual.

1.2 Revision

Athena Wireless reserves the right to revise this documentation periodically without any obligation to provide notification of such revision or changes.

1.3 Prior knowledge

This manual assumes that the installer has at least a basic experience and understanding of networking equipment, as well as some familiarity with its configuration and operation. The information covered in this manual should be fully understood prior to installation.

1.4 Warranty

Athena Wireless warrants to the original end user (purchaser) that this product is free from any defects in materials or workmanship for a period of up to one year from the date of shipment to the end user. During the warranty period, and upon proof of purchase, should the product show indications of failure due to faulty workmanship and/or materials, Athena Wireless will, at its discretion, repair or replace the defective products or components without charge for either parts or labor, and to whatever extent it shall deem necessary to restore the product or components to full operating condition. Any replacement will consist of a new or remanufactured, functionally equivalent product of equal value, and will be offered solely at the discretion of Athena Wireless.

This warranty shall not apply if the product is modified (e.g. warranty seal is broken), misused, tampered with, damaged by an act of God, or subjected to abnormal working conditions. To obtain services under this warranty, contact the Athena Wireless Service Center. Products must be returned postage prepaid. It is recommended that the terminal be insured when shipped. Any products returned without either proof of purchase or with an outdated warranty will be repaired or replaced and the customer will be billed for parts and labor. All repaired or replaced products will be shipped by Athena Wireless to the corresponding return address 'postage paid' (USA only). If the customer specifies some other return destination beyond US borders, the customer shall bear the cost of the return shipment. This warranty gives you specific legal rights, and you may also have other rights that vary from state to state.

1.5 Copyright / Disclaimer

Copyright © 2010-2011 by Athena Wireless

The contents of this publication may not be reproduced in any part or as a whole, transcribed, stored in a retrieval system, translated into any language, or transmitted in any form or by any means, electronic, mechanical, magnetic, optical, chemical, photocopying, manual, or otherwise, without the prior written permission of Athena Wireless.

2 SYSTEM OVERVIEW

2.1 General description

The A060-Mini® system operates as a data link in the unlicensed 60 GHz band between 57 GHz and 64 GHz.

Measuring only 18cm x 18cm (7" x 7"), A060-Mini® delivers full duplex data at a rate of up to 1000 Mbps over a distance of up to 800m (2600 ft).

The terminal's compact size is attained by extensively integrating the active and passive components.



For more detailed technical data see appendix A.2.

2.1.1 Benefits

- Easy installation – The concept of the A060-Mini® link allows to the end user to install it as easy as any other network component.
The single cable solution reduces the complexity of the installation. The terminal is connected to the network, monitored and supplied with power through a single outdoor rated CAT 6 Ethernet cable.
A visual alignment tool together with an alignment bracket allow the user to easily install the link.
Immediate operation without the need for additional configuration is granted.
- Network performance – Guaranteed full duplex at 1000 Mbps along the complete range. Unlike typical WLAN equipment the user can transmit a full 1000 Mbps over the link.
- License free operation – The system has been approved and can be operated in many countries.
- System administration – To monitor the status and the traffic the user can access the link statistics either via the HTML user interface or by integrating it into a network management tool via SNMP.
- Security – The proprietary radio interface does not allow any other system to access the 60 GHz transmitted data.
A high level of data security is inherent in the product via signal absorption by atmospheric oxygen and the use of high gain/narrow beam-width antennas.

2.1.2 Applications

- LAN extension
- Backhaul
- Redundant access
- Campus connectivity
- Disaster recovery •Wireless backhaul
- Centralization of IT infrastructure
- Temporary connections during events

- Mesh, hub and spoke configuration

2.2 Package contents

All equipment and installation material is packed into one box. This is divided into three cartons containing the following items:

- Carton A:
 - Terminal A
 - Bracket
 - Mounting set
- Carton B:
 - Terminal B
 - Bracket
 - Mounting set
- Carton C:
 - Manual
 - Reset-CD
 - Ice bridges
 - Accessories
- Required tools:
 - 5mm adjustable-end wrench

2.3 System components

The A060-Mini® system is composed of the following components:

- Terminal A and Terminal B
- Alignment bracket
- Alignment tool
- Ice bridge
- Sealed Ethernet connection
- Main accessories:
 - PoE injector
 - Mast bracket
 - Ethernet cables
 - Lightning protector

2.3.1 Terminals

The terminals are the main system components. They combine the antenna and the transmitter and receiver. The terminals are connected to the network via a standard Cat 5e Ethernet cable with RJ-45 connectors.

Power is supplied to the terminal through the Ethernet cable. This will require either compatible network equipment or a PoE+ injector.



2.3.2 Alignment bracket

The alignment bracket facilitates easy radio alignment owing to its independent axes. It has coarse and fine alignment capabilities.



2.3.3 Alignment tool

The optical alignment tool provided is easily mounted on the terminal using the locator pins and large thumb screw. It enables both ends of the link to be aligned quickly, simply and independently.



2.3.4 Ice bridge

The ice bridge offers additional protection for the terminal against rain, snow and ice-formation.



2.3.5 Accessories

2.3.5.1 PoE+ injector (accessory)

The terminal is powered via an Ethernet cable according to the IEEE 802.3at PoE+ standard. Should the network equipment connected to the A060-Mini® link not offer PoE+, a power injector can be inserted in line with the Ethernet cable.



2.3.5.2 Mast bracket (accessory)

The mast bracket is used to mount the bracket onto a mast. The bracket is suitable for any pole diameter from 50 mm to 115 mm (2" to 4.5").



3 SITE PLANNING

All installers must perform a full site inspection and plan carefully prior to the physical installation of an A060-Mini® system.

- This preparation must include:
- Evaluating the most appropriate location for the installation of the terminal.
- Identifying an appropriate mounting structure (wall or mast) for each terminal.
- Planning the cable routing from the network component to the terminal.

3.1 Terminal location

When selecting the best terminal location the following factors should be considered:

- Accessibility (e.g. roof)
- Type of mounting (e.g. wall or pole)
- Grounding connection point
- Cable runs (max. 100 m / 328 ft)
- Line of sight

Use of given protection against sun, rain, etc. will increase the A060-Mini® performance.

3.2 Line of sight

To ensure a clear line of sight, there must be no obstructions between the two terminal locations. The required clearance can be established visually using the following table¹:

Link Distance	Boundary Diameter
100 m (328 ft)	0.7 m (2.3 ft)
200 m (656 ft)	1.0 m (3.3 ft)
400 m (1312 ft)	1.4 m (4.6 ft)
600 m (1968 ft)	1.7 m (5.6 ft)
800 m (2625 ft)	2.0 m (6.6 ft)

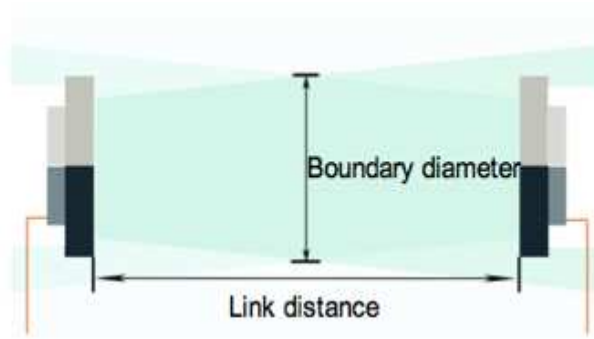

For the rain regions in your country, see appendix A.4.

¹ Fresnel zone calculation

3.4 TERMINAL MOUNTING OPTIONS

3.4.1 Wall mounting

The wall mounting location should be strong enough to secure the terminal to the wall, taking into account all foreseeable environmental conditions (e.g. wind, rain, ice).

Depending on the material to which the bracket is mounted, differently sized mounting hardware may be necessary. To mount the terminal onto the bracket use the enclosed M6 bolts. The bracket allows a tilt angle of +/- 50° in both axis.



3.4.2 Pole mounting

The pole mounting kit will be needed to mount the terminal onto poles with diameters from 50 mm to 115 mm (2" to 4.5").

3.5 Cabling

The terminal is delivered with an Ethernet cable terminated with a RJ-45 plug connector. To connect the A060-Mini® link to your network, use a Cat 5e Ethernet cable with a maximum length of 100 m to the next network node. Please verify too that the cable used is designed for outdoor environments (e.g. water, solar UV). Since the power is supplied by the Ethernet cable, please make sure that network equipment used supports Power over Ethernet Plus(PoE+).

3.6 Grounding / Lightning protection

The terminal must be properly grounded to provide protection against voltage surges.

In the event of a short circuit or lightning strike, effective grounding can prevent damage to building, equipment, infrastructure and personnel. For installations in the USA, refer to Article 830 of the National Electrical Code (Network-powered broadband communications systems). For all other countries, implement protection in accordance with the safety standards and regulatory requirements of the country in which the equipment is installed.

Athena Wireless strongly recommends the use of outdoor lightning protectors

3.7 Co-located applications

Owing to the compact size of the A060-Mini® integrated terminal, it is particularly suitable for co-sited applications.

Possible configurations include:

- Back-to-back - doubles the link distance
- Parallel link - doubles data capacity or redundancy
- Star - hub and spoke

[To deploy a co-sited application, please contact Athena Wireless to assist with devising an appropriate site design.](#)

4 INSTALLATION

Owing to the small size and integrated design of the A060-Mini® link, its correct installation and setup is relatively simple.

Nevertheless, when working on a roof, ladder, mast or staging, please take extreme care, observing all facility and OSHA (or other applicable regulatory agency) required safety precautions.

4.1 Mount installation

4.1.1 Wall mount

The wall and mounting screws must be able to support a weight of 11 pounds (5 kg), taking into account associated wind and potential ice loading factors.



Please note that the wall mount must be installed with the proper orientation as shown below.

4.1.2 Mast mount

- Ensure that the mast used has a diameter of between 50 mm to 115 mm (2" to 4.5").
- Fasten the mast bracket onto the mast using the enclosed stainless steel screws, nuts and washer (M6).
- Fasten the alignment bracket onto front part of the mast bracket using the enclosed stainless steel screws, nuts and washer (M6).



Do not use zinc plated screws as these will corrode and endanger link performance and safety to people and equipment.

4.2 Terminal installation

It is important to install the terminal on the bracket with the same orientation (antenna polarization) at both ends of the link. The terminal must be mounted on the bracket in such a way that the polarization arrow points to the same direction at both ends of the link. The terminal must be mounted on the bracket by using the enclosed stainless steel screws (M6 x 12).



Do not use zinc plated screws as these will corrode and endanger link performance and safety to people and equipment.

4.3 Cable installation

The length of the cable from the terminal to the next network component may be up to 100 m (328 ft), but should be kept as short as practical in order to reduce signal loss. All Ethernet cables must be CAT 5e compliant and suitable for outdoor use. The cable must be UV stable, UL approved and must comply with local and/or national building codes.

4.4 Antenna alignment

One of A060-Mini® link's biggest advantage is its fast, easy alignment procedure. The terminals can be coarse aligned optically by using the alignment tool. Electrical alignment is then used for fine grain accuracy.

The table below shows alignment tolerance:

Link Distance		Alignment Accuracy	
100 m	328 ft	0.9 m	2.9 ft
400 m	1312 ft	3.5 m	11.5 ft
600 m	1968 ft	5.2 m	17.2 ft
800 m	2625 ft	7.0 m	22.9 ft

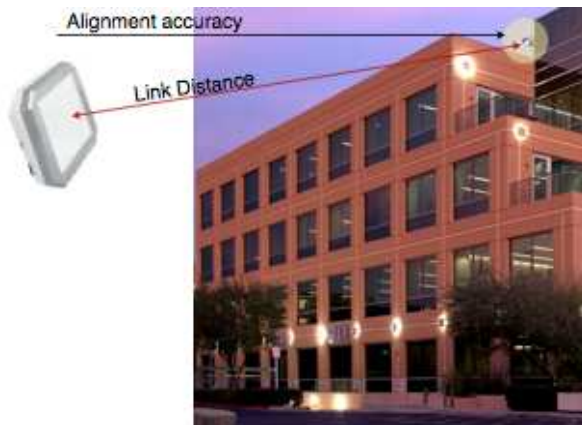

4.4.1 Alignment Procedure

The following procedure achieves fast, accurate alignment (for all operations, the enclosed 5 mm allen key can be used):

4.4.1.1 Optical alignment

1. Place the alignment tool to the most accessible corner and ensure good visibility to the opposite terminal by rotating the telescope.
2. Loosen the horizontal lock screws (labeled "3")
3. Place the horizontal axis course screw in its middle position (needle).
4. Carry out a rough alignment on the horizontal axis and fasten the screw (labeled "1").
5. Repeat steps b), c) and d) for the vertical axis.
6. Turn the horizontal course screw (labeled "2") by viewing through the telescope and carrying out the fine alignment.
7. Repeat e) for the vertical axis.
8. If necessary, repeat the fine alignment procedure e) for both axes until the opposite link is correctly aligned.
9. Fasten the lock screw (labeled "3") on both horizontal and vertical axes.

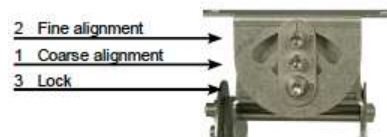
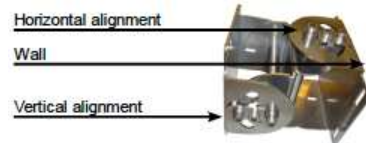

4.4.1.2 Power level alignment

Following optical alignment, an alignment based on the received power level of each terminal should be done. Use a voltmeter and cable with a banana jumper connector to attach to the bulkhead receptacle connector on the terminal. Follow points 2 to 9 of the procedure for optical alignment to obtain maximum voltage from each terminal.

A power level of -60dBm is better than a power level of -70dBm

4.5 Grounding

The terminal must be properly grounded.

Two screws are provided on the rear housing of the terminal to facilitate the correct grounding. To fasten the grounding cable onto the terminal, use a lug and serrated washer combined with an M8 nut. Connect the terminal to the connection points nearest to the building-to-earth ground point. The grounding conductor must be as short as is practical and should not exceed 6 m (20 ft). For installations in the USA, refer to Articles 830 of the National Electrical Code (Network- powered broadband communications systems). For installations in all other countries, refer to the safety standards and regulatory requirements.



4.6 Lightning / Surge protector

Athena Wireless strongly recommends the use of outdoor data line protectors.

To protect humans and property, a lightning/surge protector must be installed before the power cable enters the building.

4.7 Power injector

The power injector is connected in-line with the data line. The maximum distance between the PoE injector and the A060-Mini® link is 100 m (328 ft)

The PoE injector must be IEEE 802.3at compliant (PoE+). To check that the injector is functioning correctly, use a PoE Tester.



5 TERMINAL MANAGEMENT AND MONITORING FUNCTIONS

The A060-Mini® link is configured from the factory with default IP addresses as shown below. Use a PC or laptop to change these defaults by connecting to the terminal with the appropriate IP. Every terminal is labeled with its terminal type (A or B).

The factory default values are:

Terminal	IP Address	Subnet Mask	Username	Password
A	192.168.1.21	255.255.255.0	na	na
B	192.168.1.22	255.255.255.0	na	na

To communicate with the terminal, ensure that the IP address of the computer used is not allocated automatically by a DHCP server. Configure the IP address of the computer manually (e.g. ip 192.168.1.100 with subnet mask 255.255.255.0). Ensure that your web browser is not using any proxy server settings.

Note: The IP address settings have no influence on data connectivity. These settings are only needed to access and monitor the terminal.

5.1 Web browser interface

A web browser can be used to access and change user defined settings on the A060-Mini® link. All information is contained on one screen that is divided into five sections – Overview, Wireless Network, System and Status.

5.1.1 Overview

This screen shows an overview of key link information including, but not limited to, its serial number, version, mac address, temperature, and current status.

5.1.2 Wireless

The wireless screen is divided into setup and status.

Setup gives the Terminal type (A or B), transmit and receive frequencies and the transmit power. The transmit power can be changed between four settings depending on the distance between terminals. Make sure to click the 'Apply' button for changes to take effect.

Status shows the data rate, modulation type, link margin and receive power.

5.1.3 Network

The network configuration screen offers the option to change network settings if required. Link settings which can be changed are IP Configuration (DHCP or Static), IP address, subnet, gateway, DNS, VLAN and VLAN ID. The IP address and VLAN settings have no influence on data connectivity. The "Enable VLAN" check box allows the A060-Mini® terminals to be accessed when the link is integrated into a VLAN trunk. The VLAN ID needs to be set when the link is integrated into a VLAN trunk. Please click the Apply button to save any changes made on this screen.

This screen also displays the terminal's MAC address, MDI Setting and Network data-rate.

5.1.4 System

The system screen, divided into three sections is an all-important screen for SNMP settings. The first screen gives the terminal's serial number and allows you to enable or disable SNMP and SSH.

The second section of the system screen is where you change the system name and location, add read and write community settings and the IP address to send system alerts.

The third section of this screen is where you enable or disable alerts and temperature alert, and set the temperature high and low limits for triggering an alert.

5.1.5 Status

The status screen like the overview screen is an information only screen. It too is divided into three sections. The first gives information on the life uptime, current uptime, temperature, network data-rate and wireless data-rate. The second section is a comprehensive list of information of incoming and outgoing data packets.

5.4 SNMP interface

Object	OID	OID type	Description
MIB-2 (iso.org.dod.internet.mgmt.mib-2.system.x / .1.3.6.1.2.1.1.x)			
sysDescr	.1.	DisplayString	Includes serial no.
sysUpTime	.3.	TimeTicks	Uptime of the network management
sysName	.5.	DisplayString	set in the web GUI
sysLocation	.6.	DisplayString	set in the web GUI
ATHENA-MIB A060-Mini (iso.org.dod.internet.private.enterprises.athenaminiOID.mini.x / .1.3.6.1.4.1.36043.1.x)			
A060-MiniLinkQuality	.1.	Integer	1: Green 2: Yellow 3: Red
A060-MiniReceivePower	.10.	Integer	Receive signal level [dBm]
A060-MiniTemperature	.11.	Integer	Temperature [°C]
A060-MiniLocDetector	.12.	Integer	Lock detection signal level
A060-MiniifEthernetIn	.15.	Integer	Total frames received on the Ethernet interface over a period of 10 seconds.
A060-MiniifEthernetOut	.16.	Integer	Total frames sent on the Ethernet interface over a period of 10 seconds.
A060-MiniifEthernetError	.17.	Integer	Total frames dropped due to errors received on the Ethernet interface over a period of 10 seconds
A060-MiniifAirIn	.18.	Integer	Total frames received on the Air interface over a period of 10 seconds.
A060-MiniifAirOut	.19.	Integer	Total frames sent on the Air interface over a period of 10 seconds.
A060-MiniifAirInError	.20.	Integer	Total frames dropped due to errors received on the Air interface over a period of 10 seconds.
A060-MiniFirmwareversion	.21.	String	Installed firmware version
ATHENA-MIB A060-Minitraps (iso.org.dod.internet.private.enterprises.athenaminiOID.mini.miniTraps.x / .1.3.6.1.4.1.36043.1.22.x)			
A060-MiniLinkQualityImprovedTrap	.1.	Integer	1: from red to green 2: from red to orange 3: from orange to green
A060-MinilinkQualityReducedTrap	.2.	Integer	1: from red to green 2: from red to orange 3: from orange to green
A060-MiniTemperatureHighTrap	.3.	Integer	A trap indicating that the temperature within the unit is at or above 70 degree Celcius
A060-MiniTemperatureLowTrap	.4.	Integer	A trap indicating that the temperature within the unit is at or below -40 degree Celcius

A TECHNICAL INFORMATION

A.1 Troubleshooting

This chapter provides solutions to problems that can occur during the installation and operation of the A060-Mini®. It covers various aspects of installation and network setup.

Note:

Each of the following points must be checked at both ends of the link. Start by performing the entire procedure on one side (e.g. Terminal A). If this does not solve the problem, repeat all the steps at the opposite terminal.

A.1.1 Power and network connection

You must verify that the terminal is connected to the power. The PoE injector must be installed and plugged in. Go to the terminal, disconnect the RJ-45 connector and verify if there is power in the cable using a standard PoE tester.

Take the cable and plug it into a notebook or a network testing device and verify if there is a correct network connection. If there is any problem, please replace the cable and validate the connection again. We provide special, preassembled outdoor CAT 5e cables to ensure easy installation.

A.1.2 Network configuration

Check that the IP address is in the same range and subnet as the A060-Mini®.

Note: The default IP address of the A060-Mini® is 192.168.1.21 and 192.168.1.22 for terminal A and B respectively. All terminals on the network must have a unique IP address in the same range, e.g. 192.168.1.X. Any terminal with identical IP addresses will not be visible on the network. They must all also have the same subnet mask (e.g. 255.255.255.0).

Do a Ping test to make sure that the A060-Mini® is responding. Go to Start → Run → Type "Command" → Type "ping 192.168.1.21/22". A successful Ping test will generate four replies. As soon as the network configuration is correct you can access the GUI (Graphical User Interface) and check the settings according to section 4.9.

A.1.3 Duplex mismatch

If you encounter bad network performance, you probably have a duplex mismatch. To ensure that the A060-Mini® terminal and the connected network component (e.g. switch) do not have a duplex mismatch you must first check your statistics. If you find many input errors, you are on the full-duplex side; if you see many late collisions, you are on the half-duplex side. To solve the duplex mismatch, you must manually configure both network components to the same values.

A.1.4 Miss-alignment

See the configuration interface as described in section 5.1.4. On the Radio alignment screen (see section 5.1.5) you see the signal strength in dBm (e.g. -30 dBm). If the value is below -77dBm the receiver is not in the correct position to track the signal. You therefore need to re-align the terminal to its opposite terminal (please follow the instructions in section 4.4.1).

A.2 Specifications

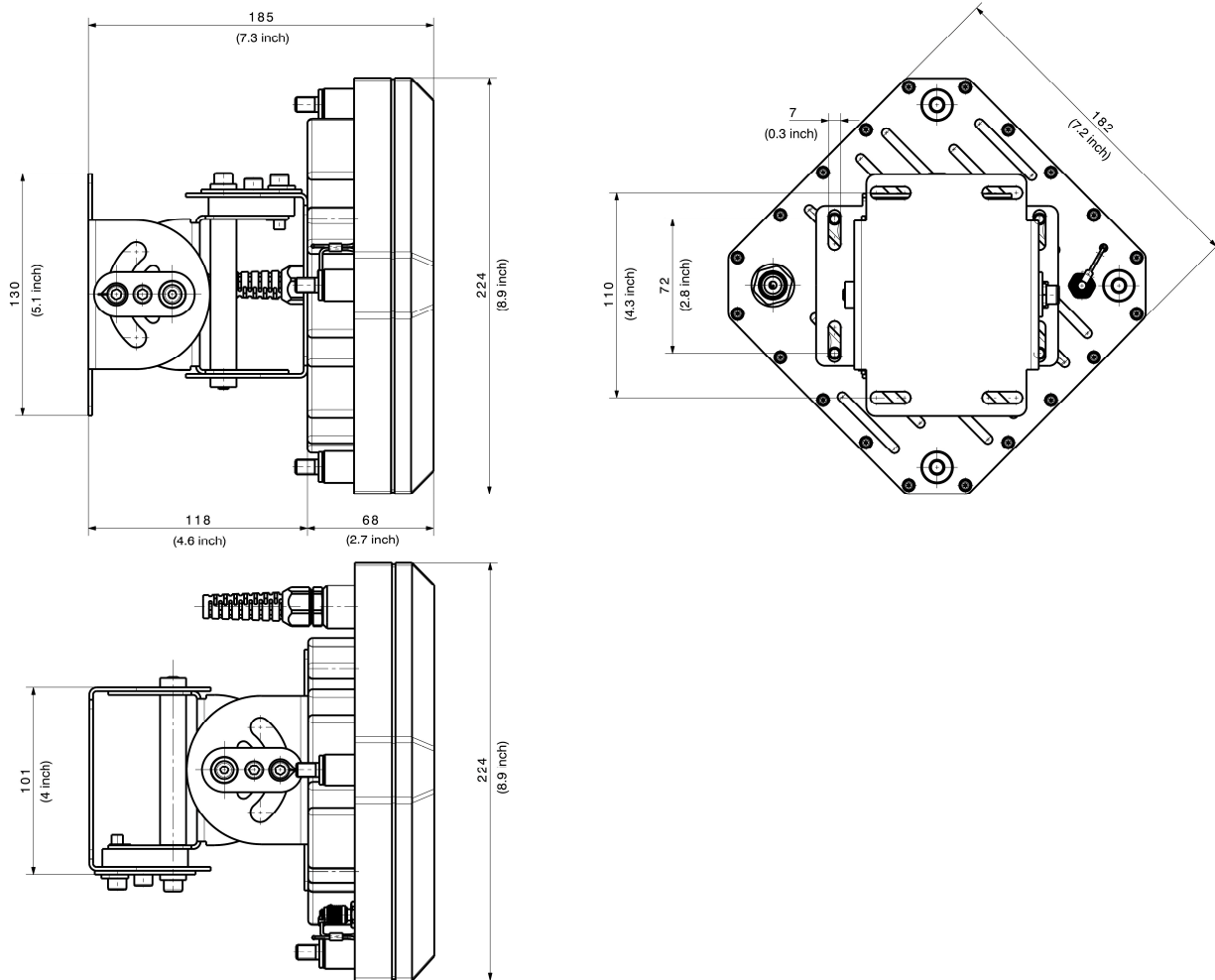

General system information

- Transmission Capacity: 1000 Mbps full duplex
- Interfaces: 1000 Base-T
- Latency : <math>< 50 \mu\text{s}</math> + distance
- (1 μs / 300 m)
- Range*: up to 1000 m (3280 ft)
- Availability*: up to 99.999%
- Warranty: 1 year
- Connection
 - Cable Length: max. 100 m (300 ft)
 - Signal Wires: CAT 5e
 - Connector: RJ-45(male; including outdoor Ethernet seal kit)
- Mechanical data
 - Dimension 182 mm x 182 mm x 89 mm (7.1" x 7.1" x 3.5")

- Weight 3500 g (7.7 lb.)
 - System administration
 - Management: SNMP
Web browser based configuration
- Power supply
 - Standards: Compliant with Power over Ethernet according to IEEE 802.3at
 - Working Temperature **: - 45 °C ... + 55 °C
(- 49 °F ... + 131 °F)
- Storage Temperature: - 30 °C ... + 55 °C
(- 22 °F ... + 131 °F)
- Wind Load: operating 160 km/h (100 mph)
survival 200 km/h (125 mph)
- Regulatory
 - Regulatory Compliance: FCC Part 15
Industry Canada RSS210
R&TTE Directive 1999/5/EC
- Ordering information
 - A060-Mini®: Item #
 - A060-Mini®: Item #
 - each composed of: 2 Terminals
 - 2 Alignment brackets
 - 1 Manual
 - 2 Mounting sets

* The range depends on the climate zone and the requested availability

** Only if the terminal is powered up

A.2 Availability / Rain Zone / Link Distance

The link distance is directly related to the weather conditions. The table below refers to a link working at a distance of up to 800m (A060-Mini®), for dry weather conditions.

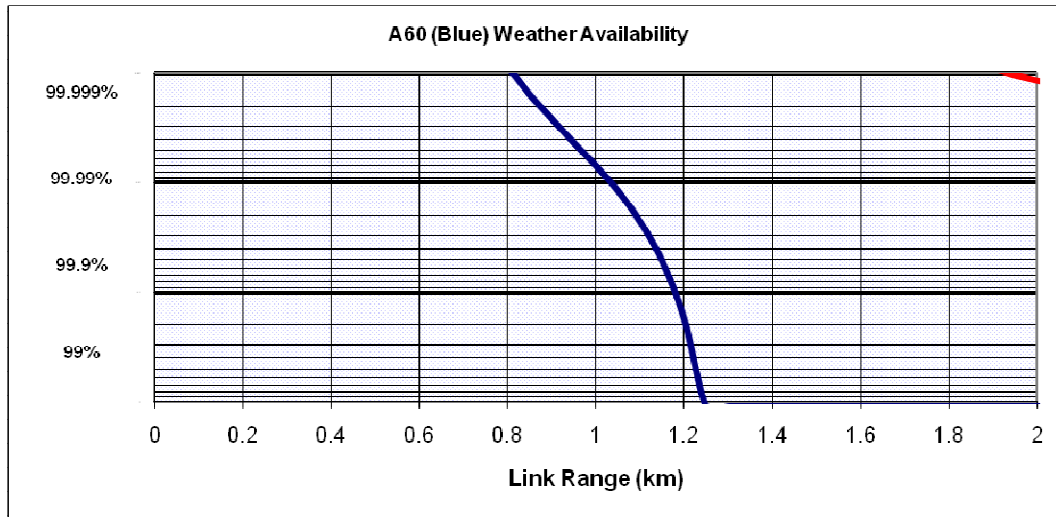

Please also refer to the maps in sections A.4.1, A.4.2 and A.4.3.

(A060-Mini®):

Availability	Rain zone * Link Distance (m)														
	A	B	C	D	E	F	G	H	J	K	L	M	N	P	Q
99%	797	789	785	764	787	770	752	765	701	772	765	741	730	669	597
99.9%	765	752	730	701	719	701	669	684	618	669	648	607	549	461	446
99.99%	701	669	648	624	607	578	569	561	549	524	473	466	405	343	376
99.999%	607	561	524	524	450	434	461	425	486	397	338	370	312	268	320

* Rain zone according to ITU-R Recommendation PN.837-1

99.9% availability equates to 526 minutes per year of outage due to heavy rains.

99.99% availability equates to 53 minutes per year of outage due to heavy rains.

99.999% availability equates to 5 minutes per year of outage due to heavy rains.

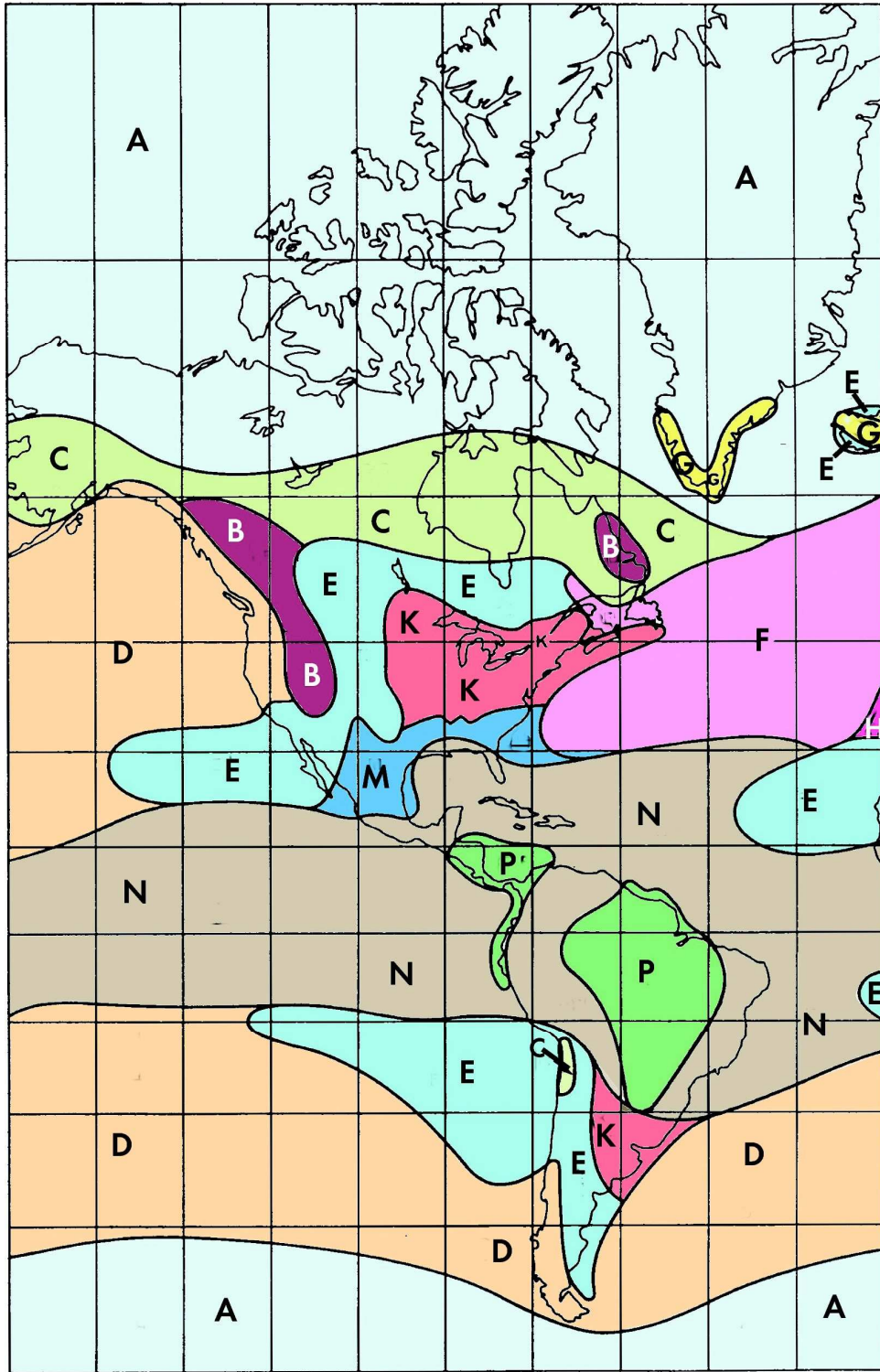

A. Map Of America

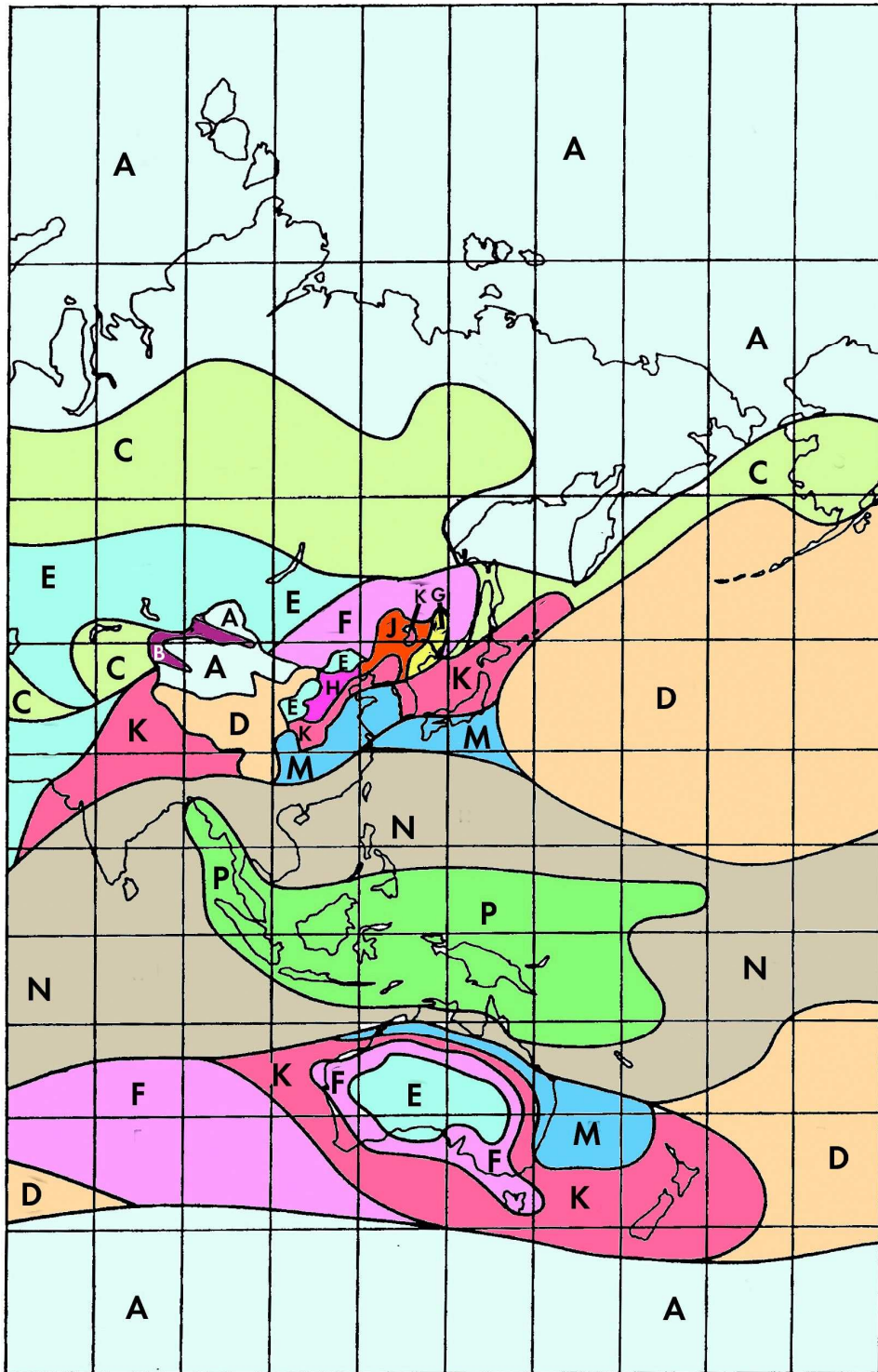

B. Map of Asia and Middle East

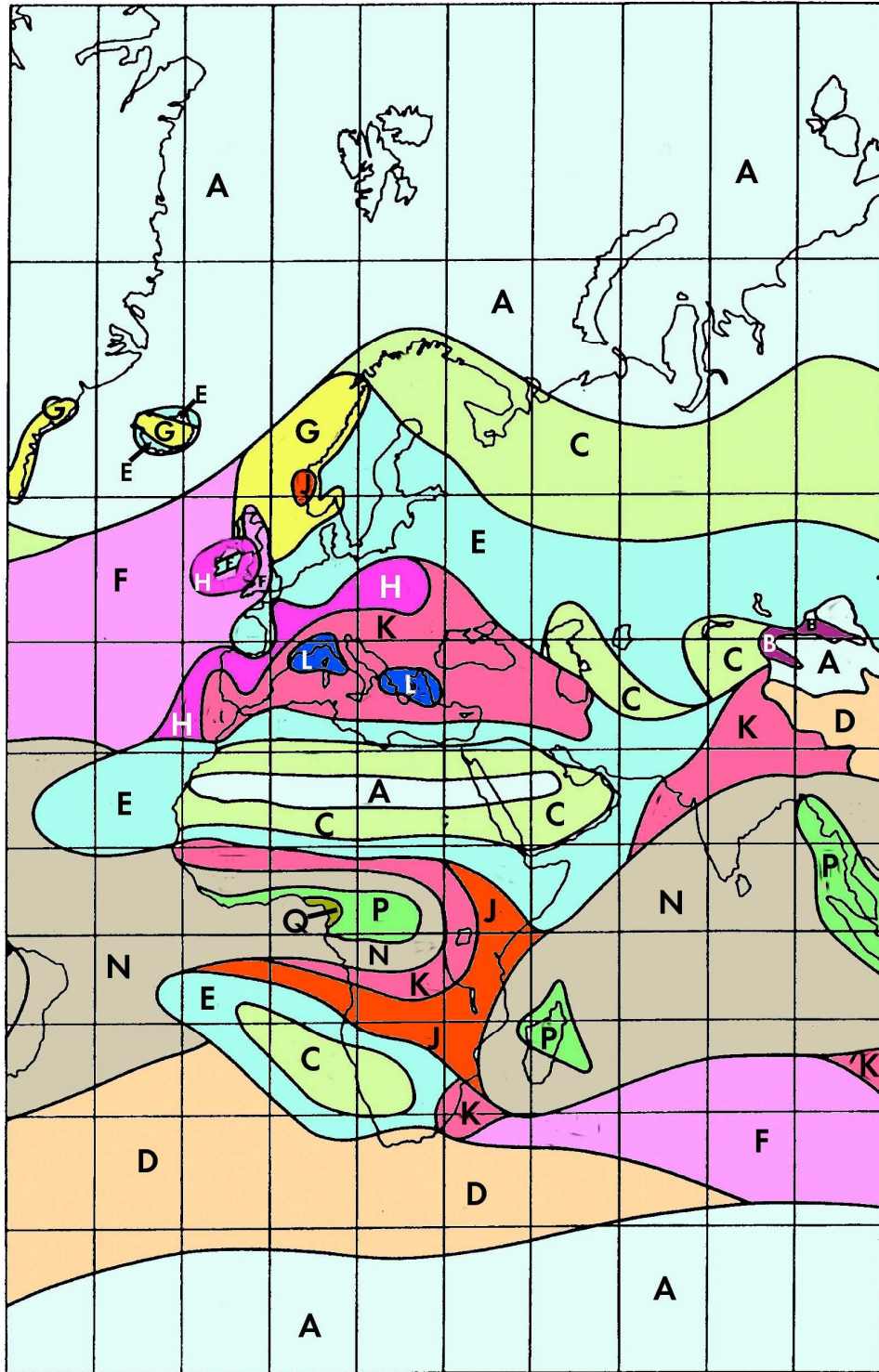

C. Map of Europe

B REGULATORY INFORMATION

B.1.1 FCC statement

Changes or modifications not expressly approved by the party responsible for compliance could void the user's authority to operate the equipment.

This device complies with Part 15 of the FCC Rules.

Operation is subject to the following two conditions:

- this device may not cause harmful interference, and
- this device must accept any interference received, including interference that may cause undesired operation.

Note: This equipment has been tested and found to comply with the limits for a Class B digital device, pursuant to part 15 of the FCC Rules. These limits are designed to provide reasonable protection against harmful interference in a residential installation. This equipment generates uses and can radiate radio frequency energy and, if not installed and used in accordance with the instructions, may cause harmful interference to radio communications. However, there is no guarantee that interference will not occur in a particular installation.

If this equipment does cause harmful interference to radio or television reception, which can be determined by turning the equipment off and on, the user is encouraged to try to correct the interference by one or more of the following measures:

- Reorient or relocate the receiving antenna.
- Increase the separation between the equipment and receiver.
- Connect the equipment into an outlet on a circuit different from that to which the receiver is connected.
- Consult the dealer or an experienced radio/TV technician for help.

FCC NOTICE: To comply with FCC part 15 rules in the United States, the system must be professionally installed to ensure compliance with the Part 15 certification.

It is the responsibility of the operator and professional installer to ensure that only certified systems are deployed in the United States.

The use of the system in any other combination (such as co-located antennas transmitting the same information) is expressly forbidden.

RF Exposure: This equipment complies with FCC radiation exposure limits set forth for an uncontrolled environment.

FCC ID: Z19-A060

B.1.2 Industry Canada statement

Operation is subject to the following two conditions:

1. This device may not cause interference, and
2. This device must accept any interference, including interference that may cause undesired operation of the device.

This Class B digital apparatus complies with Canadian ICES-003.

This equipment complies with IC RSS-102 radiation exposure limits set forth for an uncontrolled environment.

Son fonctionnement est soumis aux deux conditions suivantes:

1. Ce dispositif ne peut causer des interférences, et
2. Ce dispositif doit accepter toute interférence, y compris les interférences qui peuvent causer un mauvais fonctionnement du dispositif.

Cet appareil numérique de classe B est conforme à la norme canadienne ICES-003.

Cet équipement est conforme à l'exposition aux rayonnements IC RSS-102 des limites définies pour un environnement non contrôlé.

IC: 9662A-A060

B.1.3 CE – Declaration of conformity

We, Athena Wireless declare that the product A060-Mini® is in conformity – after consultation with the notified body Compliance testing, LLC – with the following standards and normative documents:

- EN 50371 (2002): Generic standard to demonstrate the compliance of low power electronic and electrical apparatus with the basic restrictions related to human exposure to electromagnetic fields (10 MHz - 300 GHz)
- EN 55022 (2006): Information technology equipment - Radio disturbance characteristics - Limits and methods of measurement
- EN 55024 (1998): Information technology equipment - Immunity characteristics - Limits and methods of measurement
- EN 60950-1 (2006): Information technology equipment - Safety -- Part 1: General requirements
- ETSI EN 302 217-3 V1.3.1 (2009-07): Harmonized European Standard (Telecommunications series) Fixed Radio Systems; Characteristics and requirements for point-to-point equipment and antennas; Part 3:

Equipment operating in frequency bands where both frequency coordinated or uncoordinated deployment might be applied; Harmonized EN covering the essential requirements of article 3.2 of the R&TTE Directive

- ETSI EN 302 217-4-2 (2007): Fixed Radio Systems; Characteristics and requirements for point-to-point equipment and antennas; Part 4-2: Harmonized EN covering essential requirements of Article 3.2 of R&TTE

Directive for antennas is in accordance with the following Directives:

- R&TTE Directive 1999/5/EC

We hereby declare that the equipment named above has been designed to comply with the relevant sections of the above referenced specifications. The unit complies with all essential requirements of the Directives.

C CONTACTS

C.1 Technical assistance

Please visit <http://www.athenawave.com>

C.1.2 Service center / RMA