

OV2643

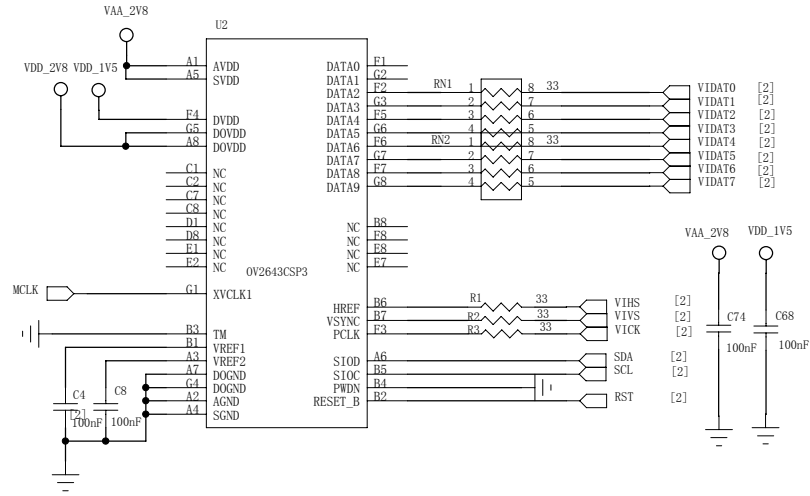

POWER

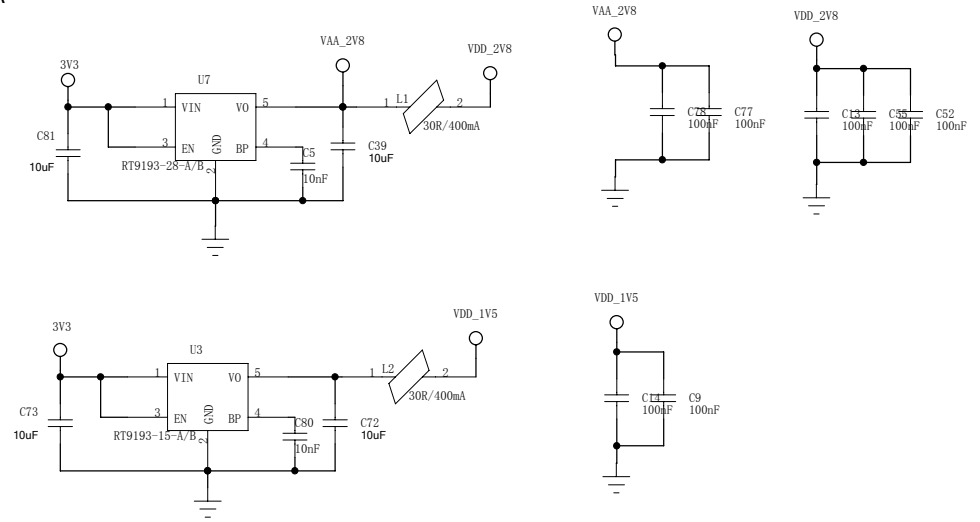

CLK&INTERFACE

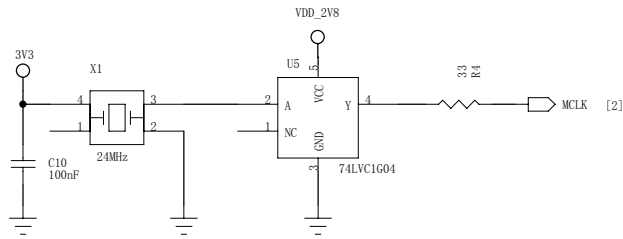

视频板接口

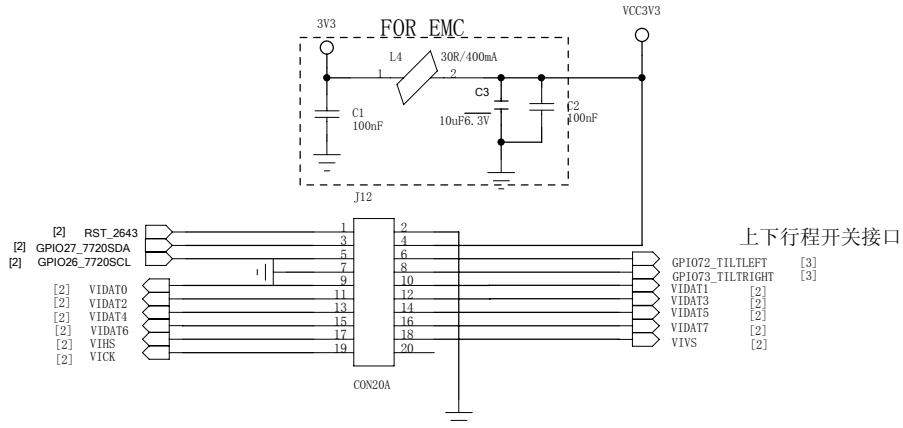

RST&I2C

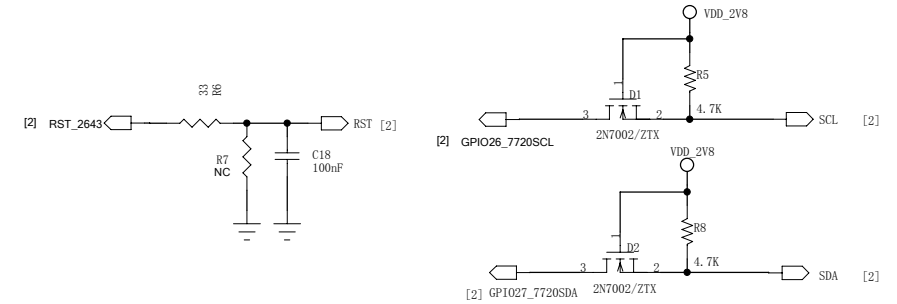

COMPANY		FOSCAM		
DESIGNED		OV2643		DATA
				2012-3-7
REVIEWED		VER	PART_NUMBER	SHEET 2 OF 3
		1.0		

IRCUT DRIVER

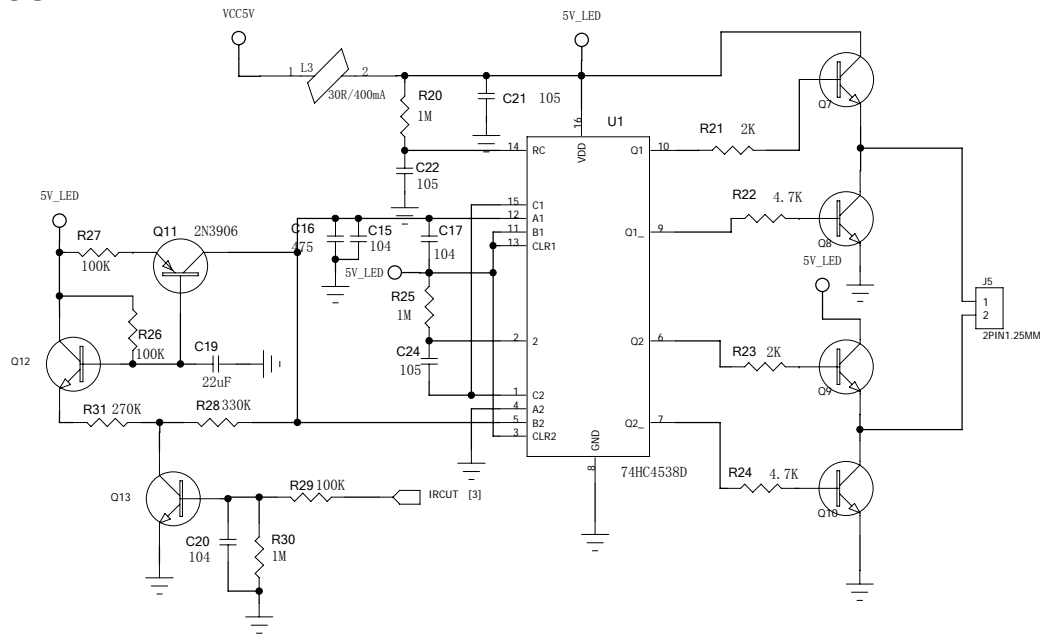

INTERFACE

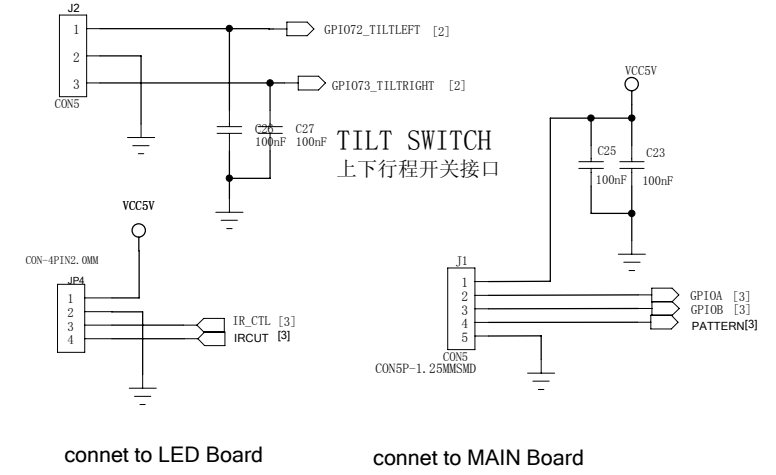

GPIO FUNTION

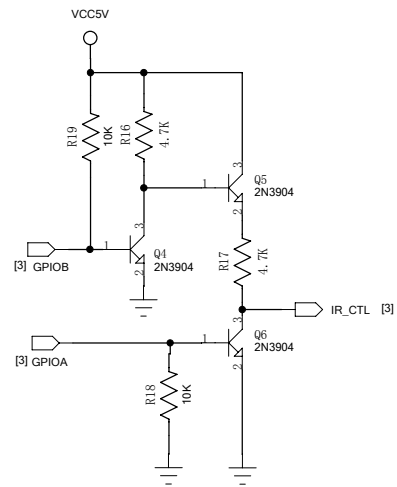

GPIOA connet to GPIO26
 GPIOB connet to GPIO27
 PATTERN connet to GPIO77

GPIOA	GPIOB	function
0	0	open,forced
0	1	auto
1	X	close,forced

IR CONTROL

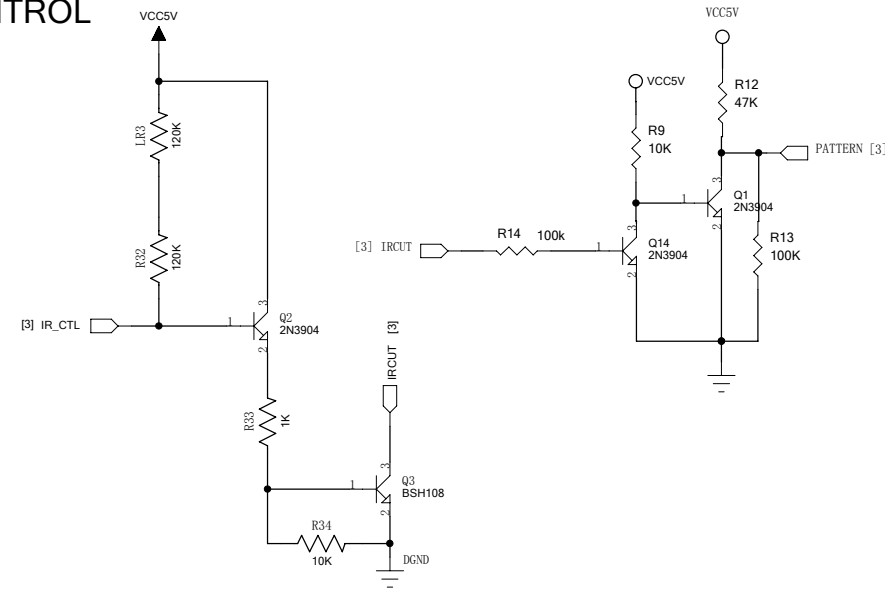

COMPANY		FOSCAM		
DESIGNED		IRCUT		DATA
REVIEWED		VER	PART_NUMBER	2012-3-7
		1.0		SHEET 3 OF 3

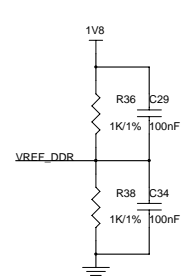
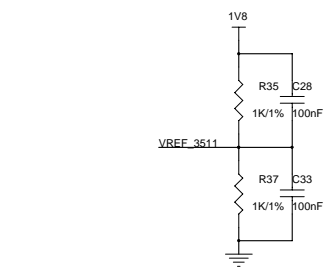
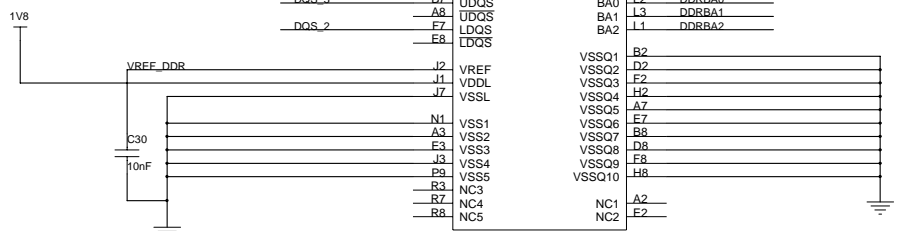
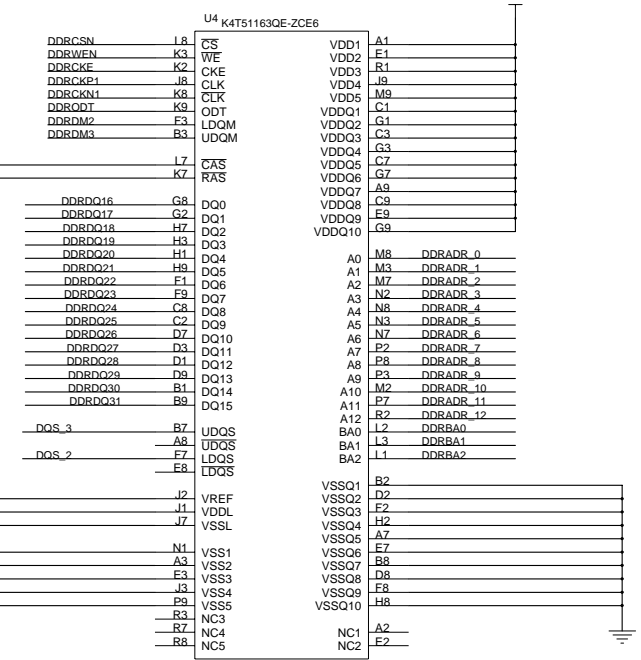
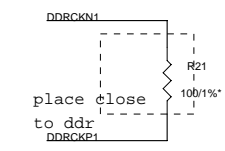
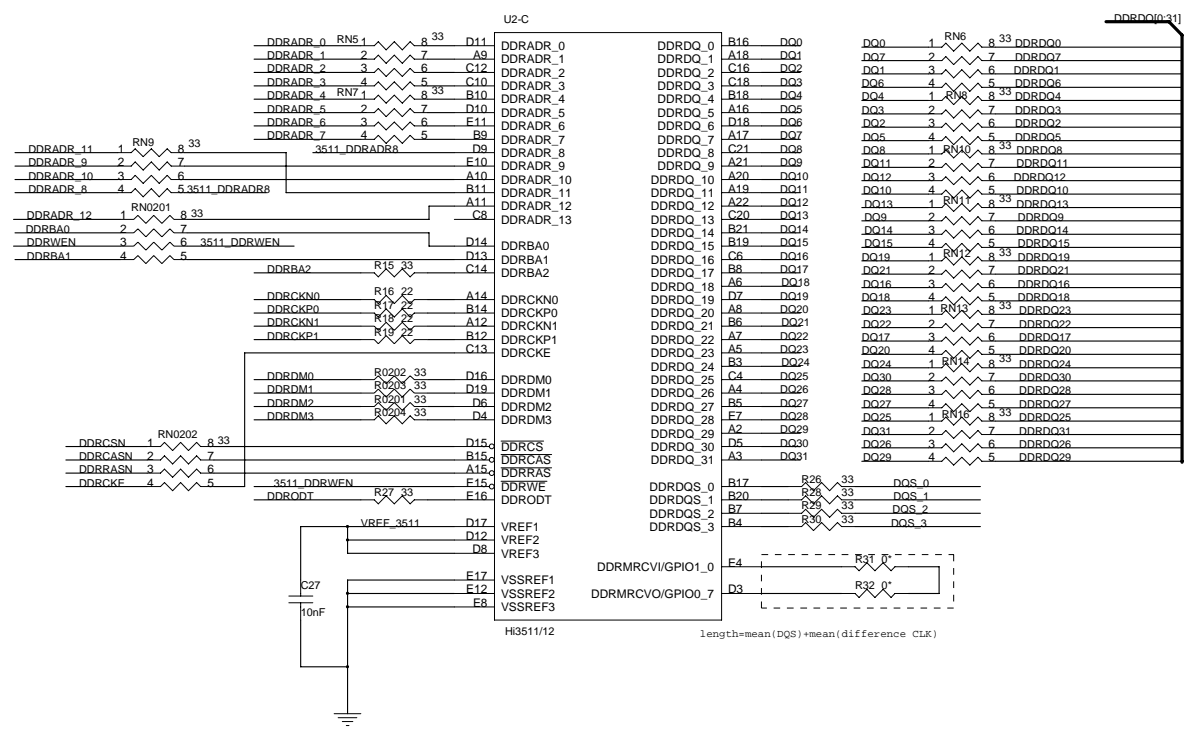
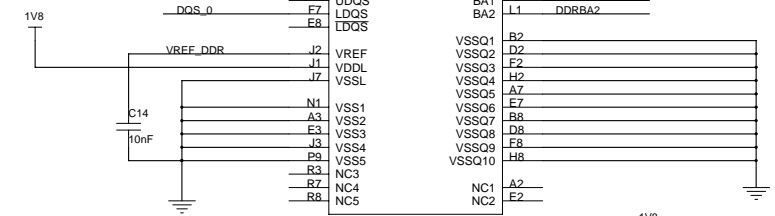
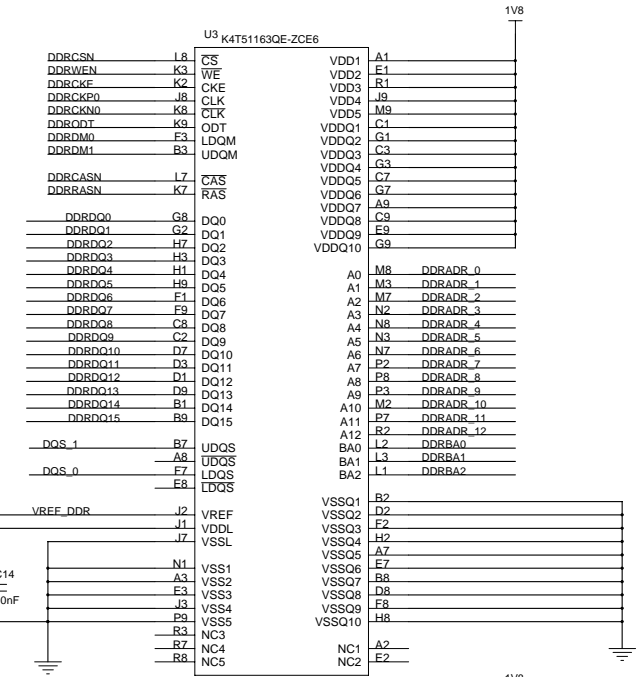
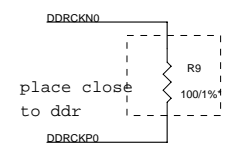
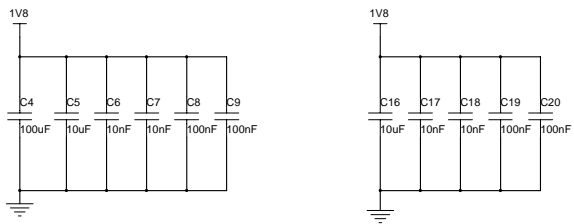

FOSCAM			
file	F18608W-MINA		
Size	Document Number	Rev	
B	DDR2_3512	V13	
Date:	2011/12/22	Sheet	3 of 11

BA2 for 1Gb
16bits only
for Hi3512

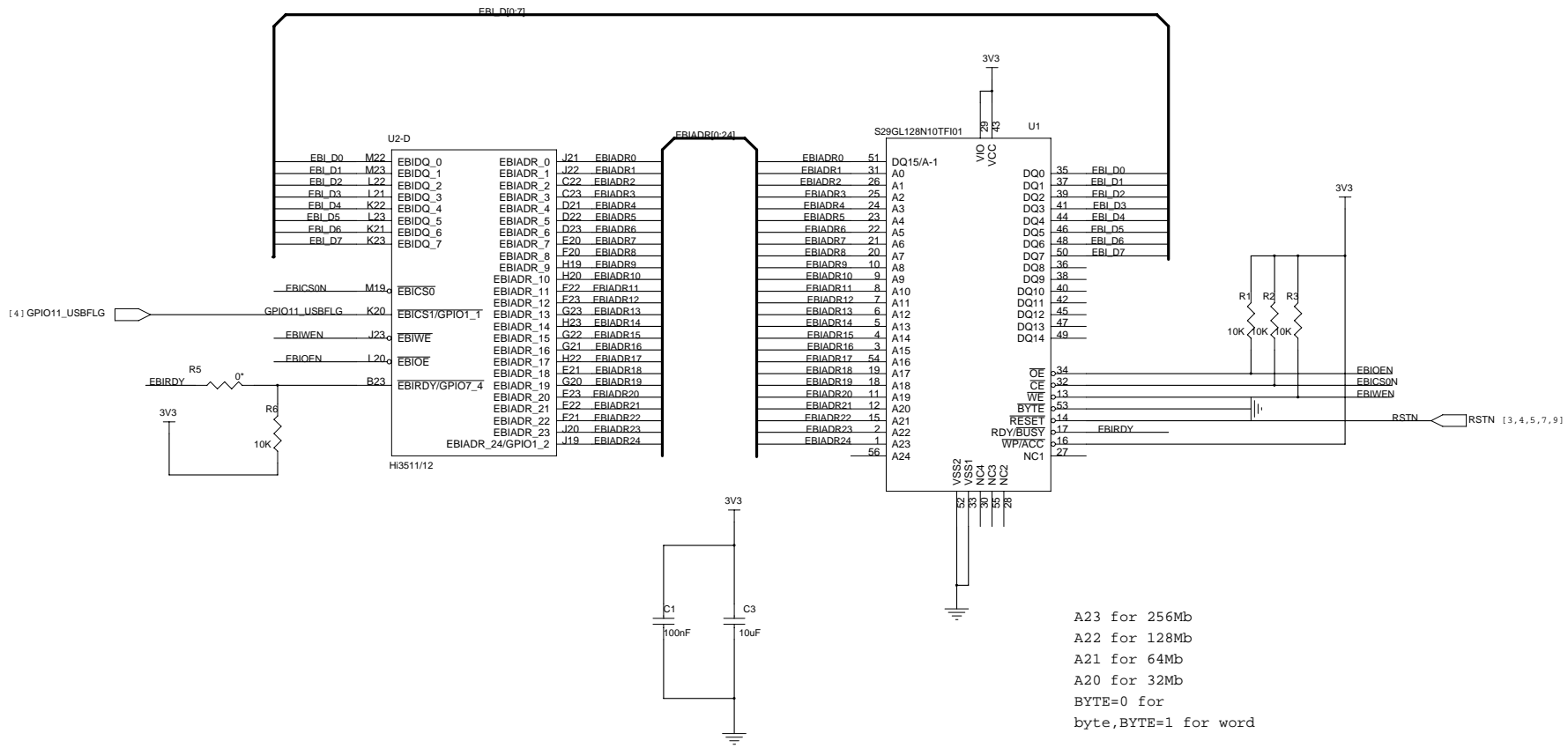

A23 for 256Mb
A22 for 128Mb
A21 for 64Mb
A20 for 32Mb
BYTE=0 for
byte, BYTE=1 for word

FOSCAM		
Title	FI8608W-MINA	
Size	Document Number	Rev
B	FLASH_3512	V1.3
Date:	2011/12/22	Sheet 2 of 11

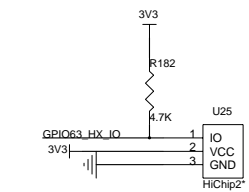
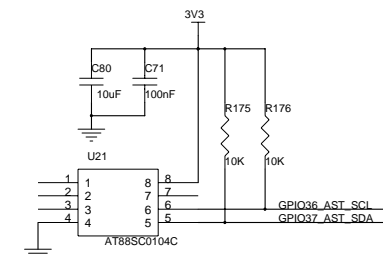
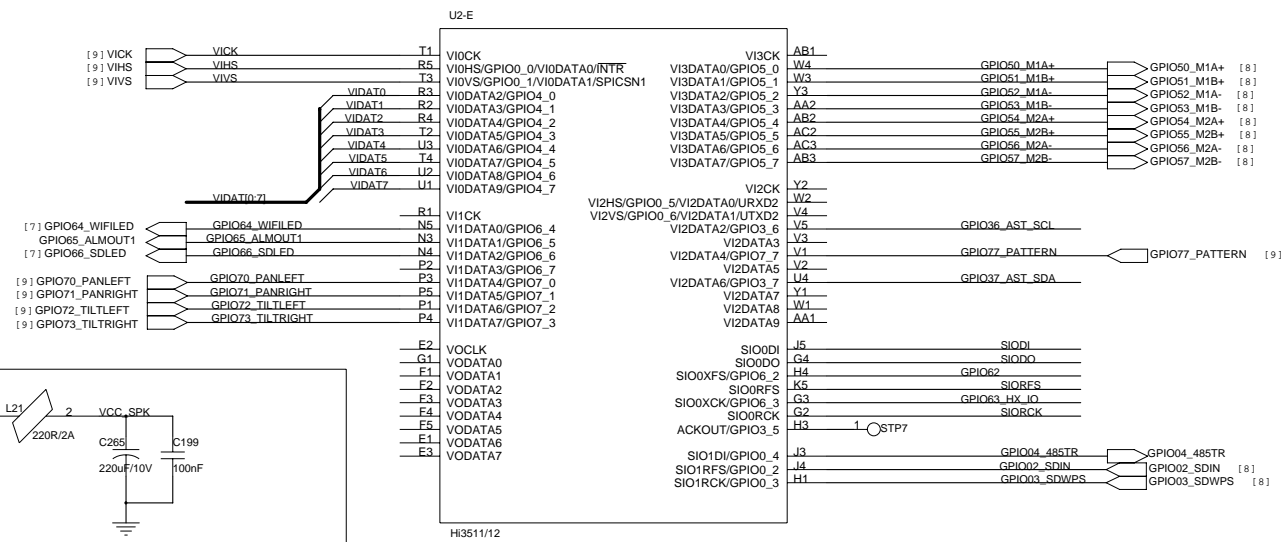

Hi3511 VIDEO AND AUDIO

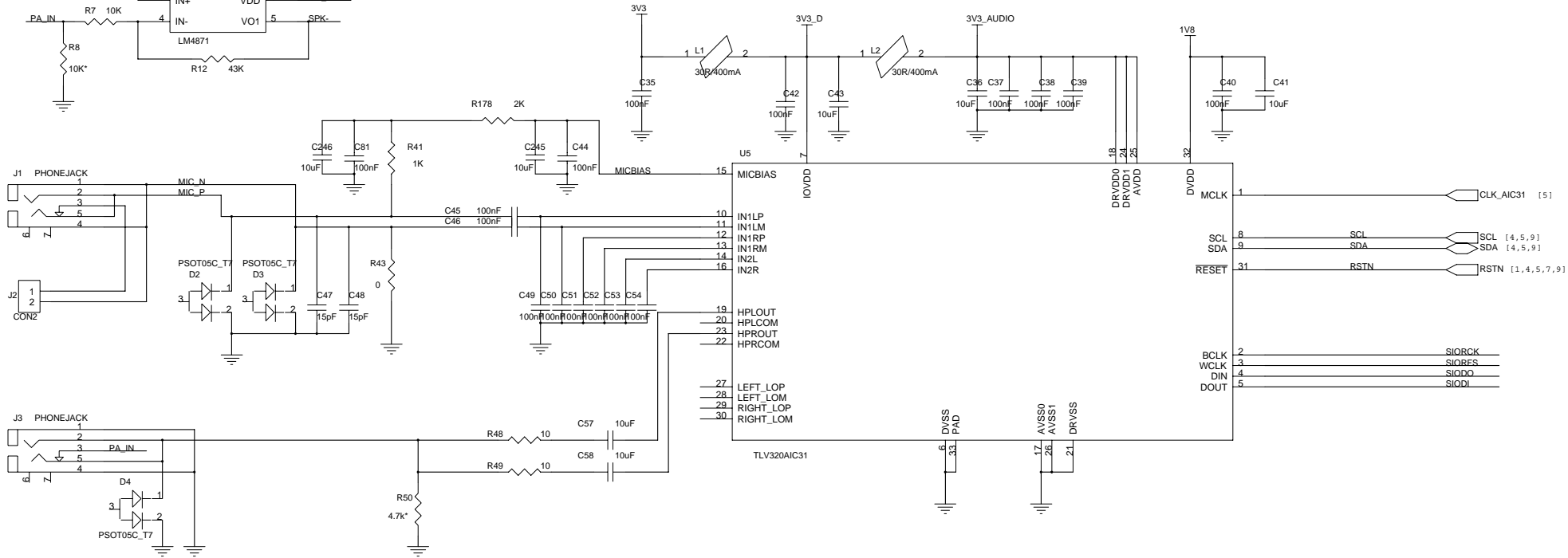
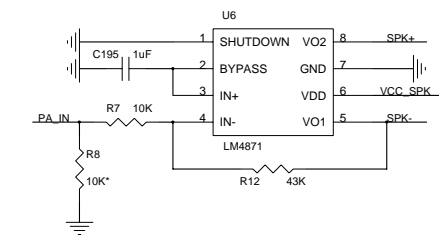
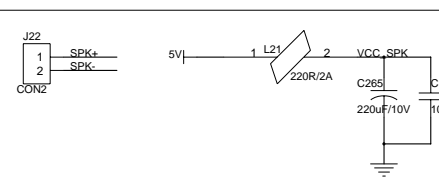

AUDIO IN AND OUT

FOSCAM		
F18608W-MINA		
Size B	Document Number	Rev
	AV_3512	V1.3
Date:	2011/12/22	Sheet 4 of 11

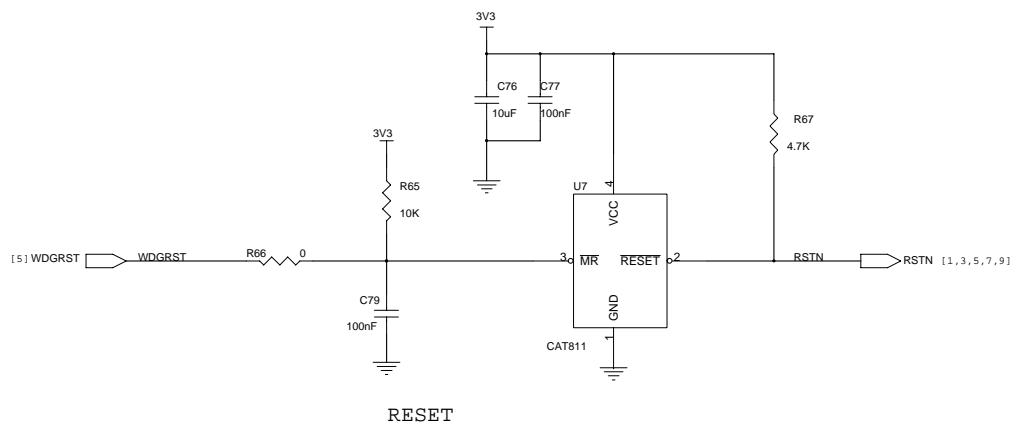
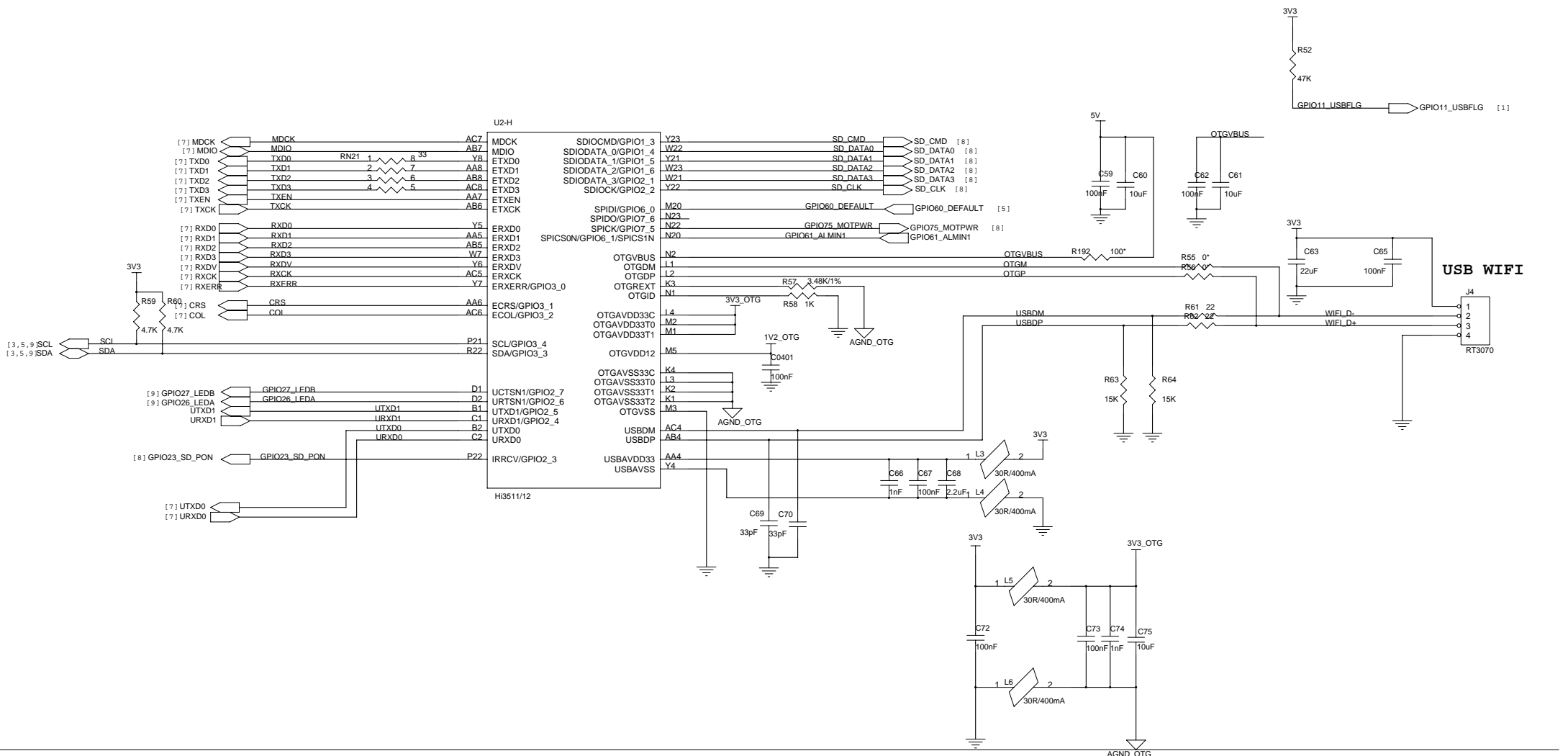

FOSCAM		
Title	F18608W-MINA	
Size	Document Number	Rev
B	OTG_RST_3512	V1.3
Date:	2011/12/22	Sheet 5 of 11

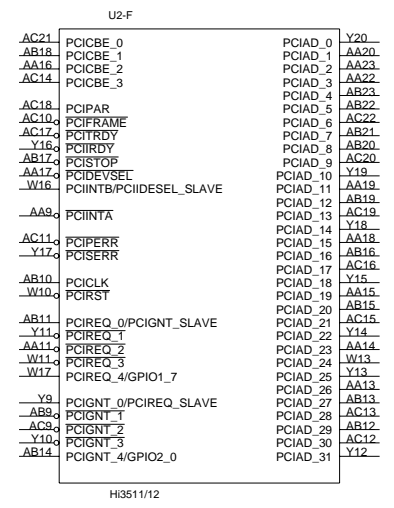
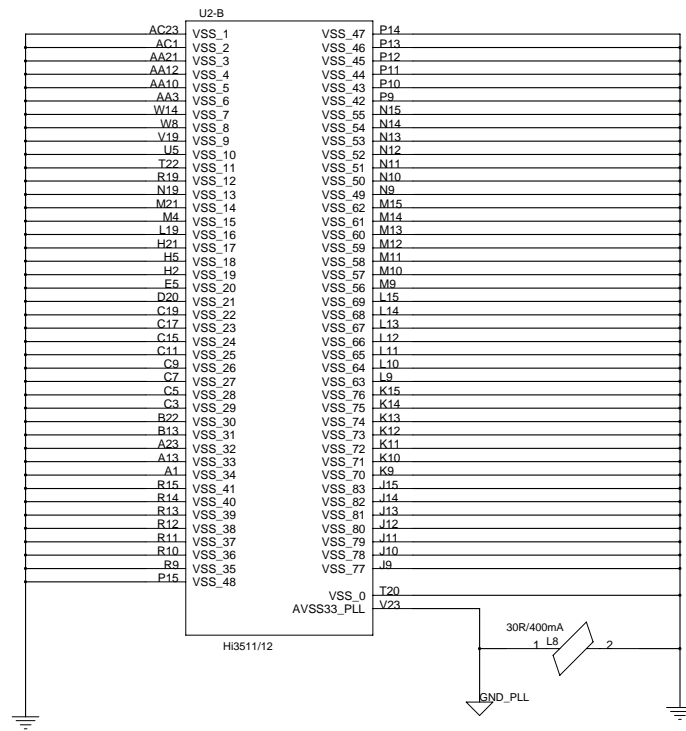
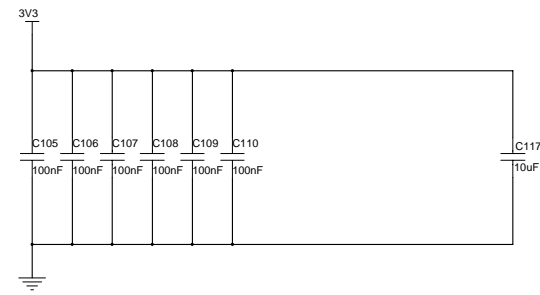
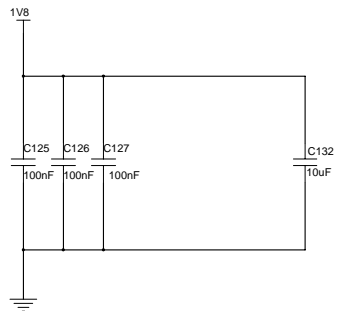
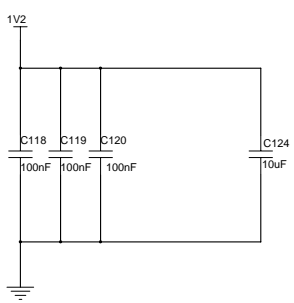
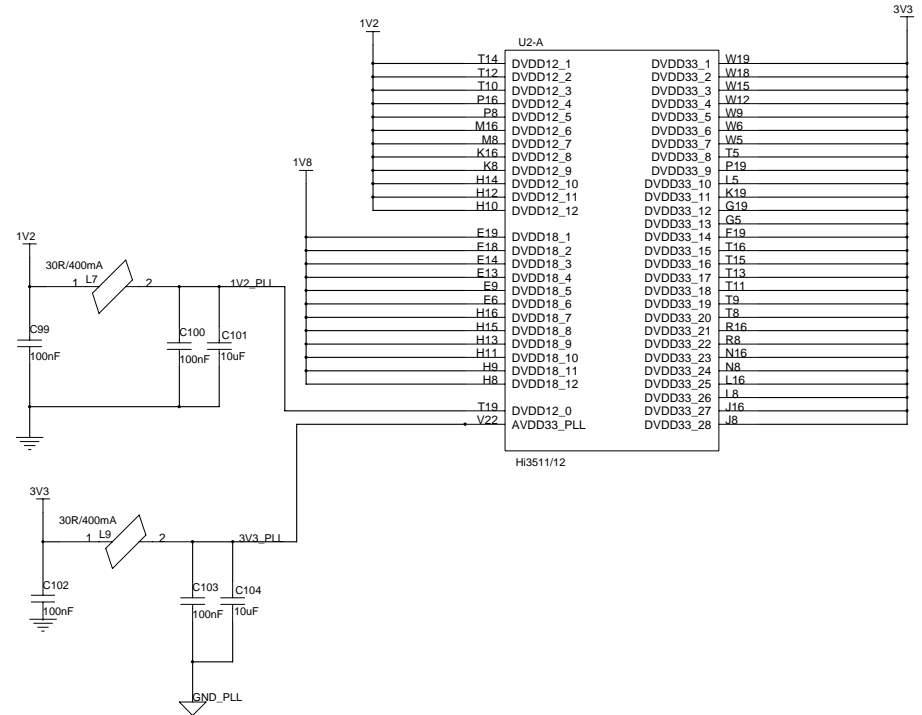

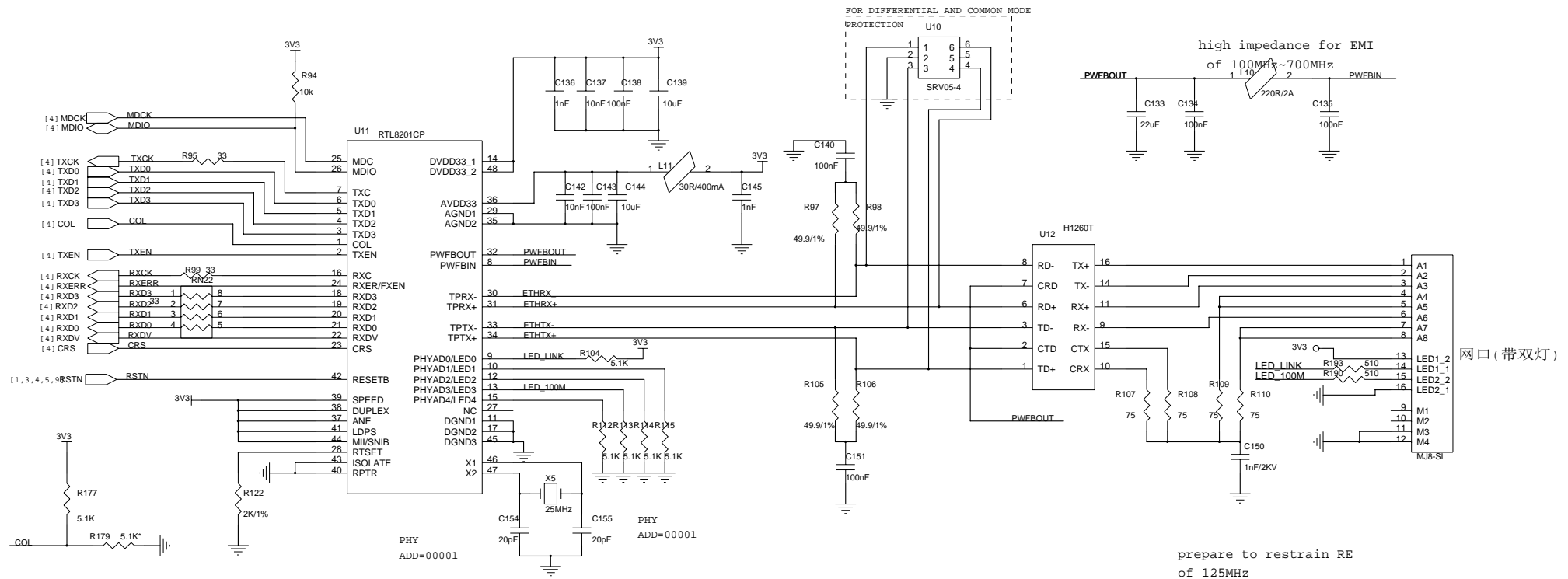

for decrease RF radiation:
 resistance for restraining differential mode;
 capacitance for restraining harmonic of 125MHz

ETH

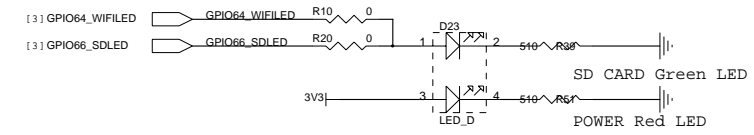
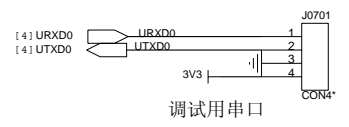

FOSCAM		
Title	F18608W-MINA	
Size	Document Number	Rev
B	ETH_UART	V1.3
Date:	2011/12/22	Sheet 8 of 11

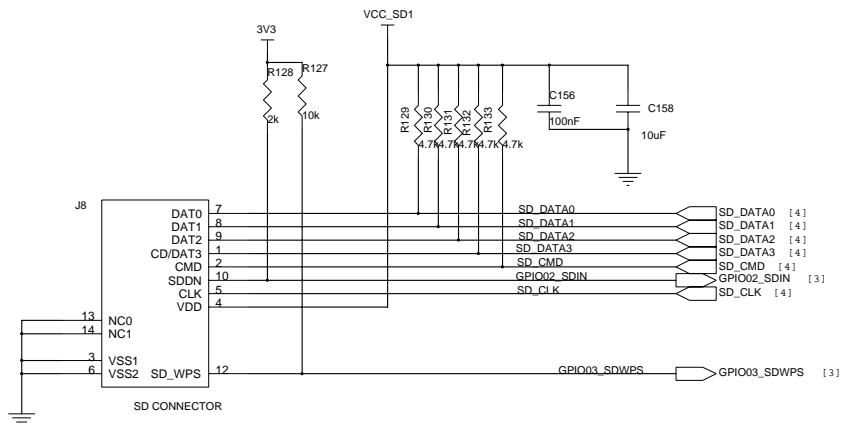

SD CARD

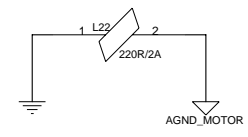
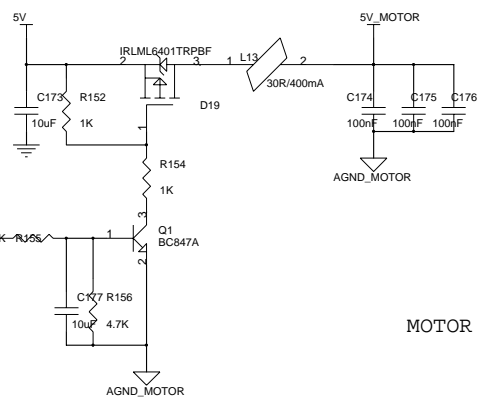
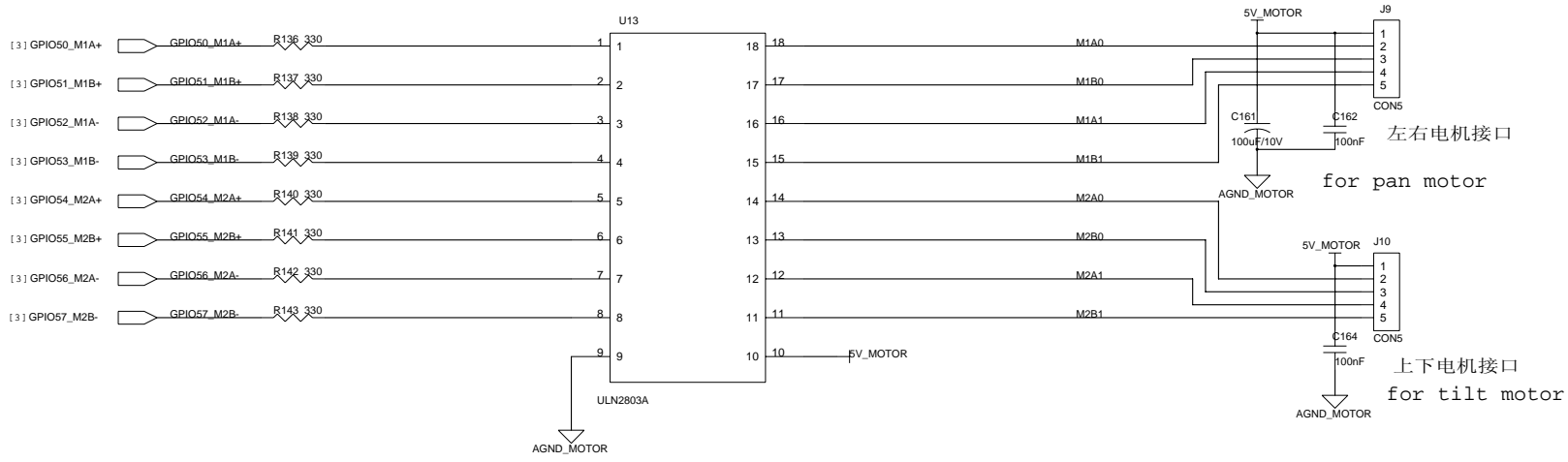
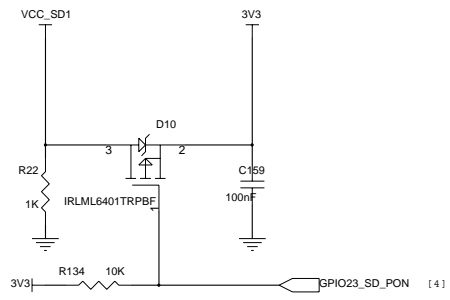

FOSCAM		
Title: F18608W-MINA		
Size: B	Document Number: SD_MOTOR	Rev: V1.3
Date: 2011/12/22	Sheet: 9	of: 11

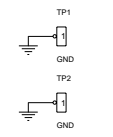
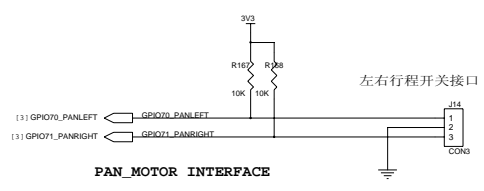
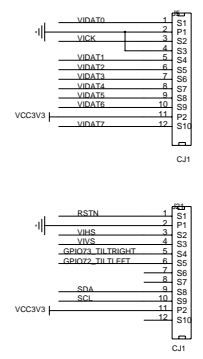
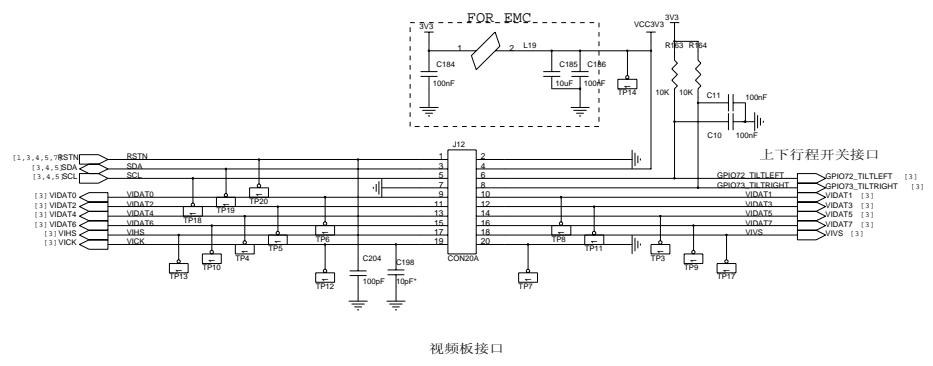
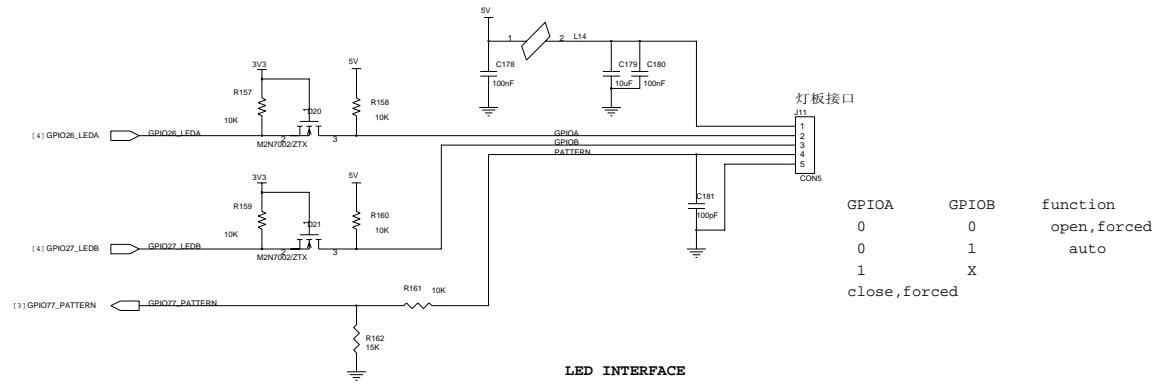

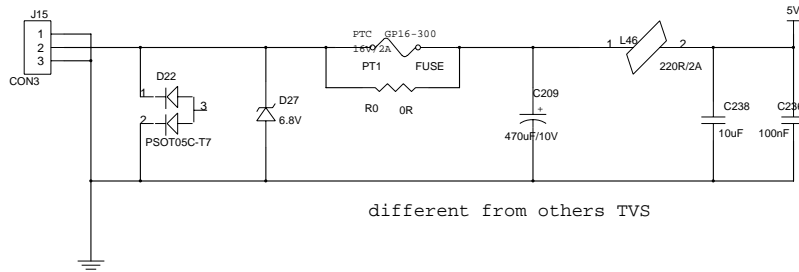

different from others TVS

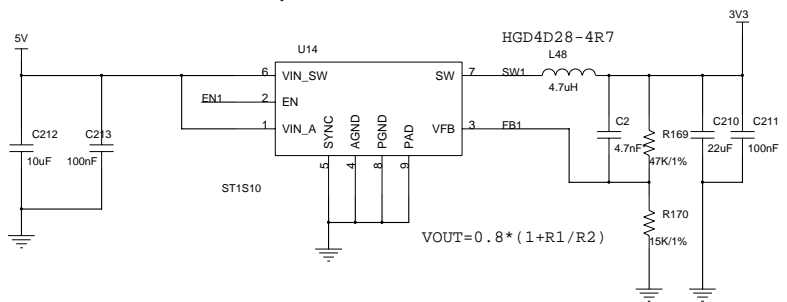
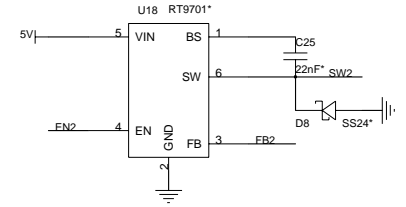
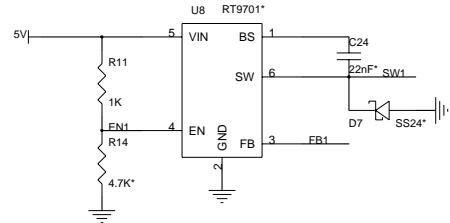

5V----3.3V

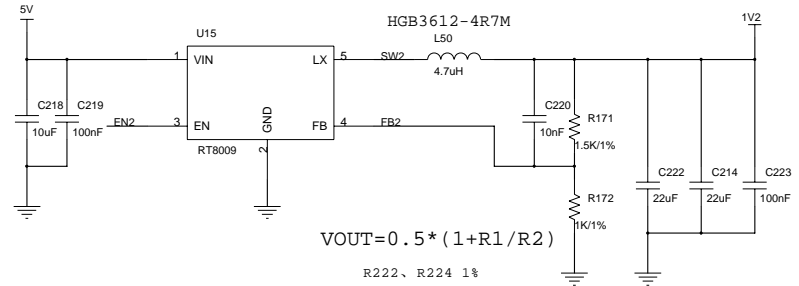

3.3V----1.25V
Hi3512 core

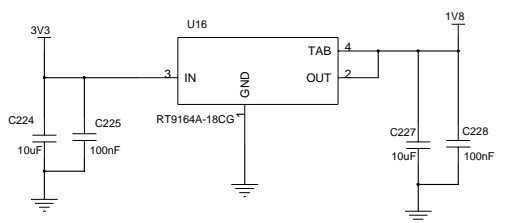

fov7720 & TLV320AIC32 core and DDR2

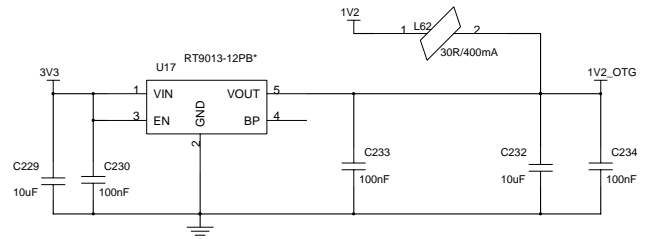
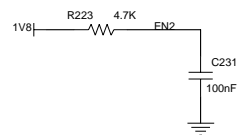

FOSCAM		
Title	F18608W-MINA	
Size	Document Number	Rev
B	POWER	V1.3
Date:	2011/12/22	Sheet 11 of 11