



FCC & IC Test Report

FCC ID: ZGM-MV2458

IC: 23051-MV2458

Product Name:	Wireless Repeater
Trademark:	MOBILEVISION, RV-LINK, TRUCK-LINK
Model Name :	MV2458
Prepared For :	MAGNADYNE CORPORATION
Address :	1111 WEST VICTORIA STEET, COMPTON, CA 90220 USA
Prepared By :	Shenzhen BCTC Technology Co., Ltd.
Address :	No.101,Yousong Road,Longhua New District, Shenzhen,China
Test Date:	Jun. 04 - Jun. 30, 2017
Date of Report :	Jun. 30, 2017
Report No.:	BCTC-LH170703072-2E



VERIFICATION OF COMPLIANCE

Applicant's name MAGNADYNE CORPORATION

Address..... 1111 WEST VICTORIA STEET, COMPTON, CA 90220 USA

Manufacture's Name MAGNADYNE CORPORATION

Address..... 1111 WEST VICTORIA STEET, COMPTON, CA 90220 USA

Product description

Product name.....: Wireless Repeater

Trademark: MOBILEVISION, RV-LINK, TRUCK-LINK

Model Name: MV2458

FCC Part15.407

RSS-247 Issue 2, February 2017

Standards.....: RSS-Gen Issue 4, November 2014

ANSI C63.10-2013

KDB789033 D02 General UNII Test Procedures New Rules v01r02

This device described above has been tested by BCTC, and the test results show that the equipment under test (EUT) is in compliance with the FCC requirements. And it is applicable only to the tested sample identified in the report.

This report shall not be reproduced except in full, without the written approval of BCTC, this document may be altered or revised by BCTC, personal only, and shall be noted in the revision of the document.

Test Result

Pass

Prepared by(Engineer): Snow Zeng

Reviewer(Supervisor): Jade Yang

Approved(Manager): Carson Zhang





TABLE OF CONTENTS

	Page
Test Report Declaration	
1. TEST SUMMARY	4
2. GENERAL PRODUCT INFORMATION	5
2.1. Product Function	5
2.2. Description of Device (EUT)	5
2.3. Independent Operation Modes	6
2.4. Test Sites	6
2.5. List of Test and Measurement Instruments	7
3. TEST SET-UP AND OPERATION MODES	8
3.1. Principle of Configuration Selection	8
3.2. Block Diagram of Test Set-up	8
3.3. Special Accessories and Auxiliary Equipment	8
3.4. Countermeasures to Achieve EMC Compliance	8
3.5. Test Operation Mode and Test Software	8
4. EMISSION TEST RESULTS	9
4.1. Conducted Emission Measurement	9
4.2. Radiated Emission Measurement	13
5. BAND EDGE COMPLIANCE TEST	28
5.1. Limits	28
5.2. TEST PROCEDURE	28
5.3. Test Data	28
6. 26DB AND 99% BANDWIDTH TEST	31
6.1. Limit	31
6.2. Test setup	31
6.3. Test result	32
7. OUTPUT POWER TEST	40
7.1. Limits	40
7.2. Test setup	40
7.3. Test result	41
8. PEAK POWER SPECTRAL DENSITY TEST	42
8.1. Limits	42
8.2. Test setup	42
8.3. Test data	43
9. DUTY CYCLE TEST SIGNAL	48
10. TRANSMISSION IN THE ABSENCE OF DATA	49
10.1. Limits	49
10.2. Test result	49
11. PHOTOGRAPHS OF TEST SET-UP	50
12. PHOTOGRAPHS OF THE EUT	52



1.TEST SUMMARY

Test Items	Test Requirement	Result
Conducted Emissions	15.207 RSS-GEN	PASS
Radiated Emissions	15.407(b), 15.209 RSS-247	PASS
26dB bandwidth and 99%dB Bandwidth	15.403(i) 15.407(e) RSS-247	PASS
Power density	15.407 (a) RSS-247	PASS
Maximum Peak Output Power	15.407 (a) RSS-247	PASS
Emissions from out of band	15.407 (b) RSS-247	PASS
Transmission in case of Absence of Information	15.407(c) RSS-247	PASS
Frequency Stability	15.407(g) RSS-247	PASS
Antenna Requirement	15.203	PASS

Note: N/A means not applicable.



2.GENERAL PRODUCT INFORMATION

2.1. Product Function

Refer to Technical Construction Form and User Manual.

2.2. Description of Device (EUT)

Product Name:	Wireless Repeater
Model No.:	MV2458
Model Difference	N/A
Trade Name:	MOBILEVISION, RV-LINK, TRUCK-LINK
Operation Frequency:	802.11a/n20: 5180-5240MHz, 802.11n40:5190-5230MHz 802.11a/n20: 5745-5825MHz, 802.11n40:5755-5795MHz
Channel numbers:	See channel list
Modulation technology:	64QAM, 16QAM, QPSK, BPSK for OFDM
Data speed (IEEE 802.11a):	6Mbps, 9Mbps, 12Mbps, 18Mbps, 24Mbps, 36Mbps, 48Mbps,54Mbps
Data speed (IEEE 802.11n):	Up to 433Mbps
Antenna Type:	external antenna
Antenna gain:	3.0dBi
Power supply:	DC 12V from adapter
Adapter	Model:GP32W-120-100 I/P:AC 100-240V 50/60Hz O/P: DC 12V 1A
Hardware version	---
Software version	---
Firmware Version	V1.0

Channel list

802.11a/n20

Channel	Frequency (MHz)	Channel	Frequency (MHz)	Channel	Frequency (MHz)
36	5180	40	5200	44	5220
48	5240	149	5745	153	5765
157	5785	161	5805	165	5825

802.11n40

Channel	Frequency (MHz)	Channel	Frequency (MHz)	Channel	Frequency (MHz)
38	5190	46	5230		
151	5755	159	5795		



2.3. Independent Operation Modes

The basic operation modes are:

Pretest Mode	Description
Mode 1	802.11a CH36/CH40/ CH48/CH149/CH157/CH165
Mode 2	802.11n(HT20) CH36/CH40/CH48/CH149/CH157/CH165
Mode 3	802.11n(HT40) CH38/CH46/CH151/CH159
Mode 4	Link Mode

For Radiated Emission	
Final Test Mode	Description
Mode 1	802.11a CH36/CH40/ CH48/CH149/CH157/CH165
Mode 2	802.11n(HT20) CH36/CH40/CH48/CH149/CH157/CH165
Mode 3	802.11n(HT40) CH38/CH46/CH151/CH159

Note:

- (1) The measurements are performed at the highest, middle, lowest available channels.
- (2) The measurements are performed at all Bit Rate of Transmitter, the worst data was reported
- (3) According to ANSI C63.10 standards, the test results are both the “worst case” and “worst setup”
MCS0 for 802.a , MCS0 for 802.11n(HT20), MCS1 for 802.11n(H40).

2.4. Test Sites

2.4.1. Test Facilities

Lab Qualifications : FCC Registration No.:187086
IC Registered No.: 12655A



2.5. List of Test and Measurement Instruments

Conduction test equipment

Item	Equipment	Manufacturer	Type No.	Serial No.	Last calibration	Calibrated until
1	Test Receiver	R&S	ESCI	1166.5950K03 -101165-ha	2016.08.27	2017.08.26
2	LISN	SCHWARZBECK	NSLK8127	8127739	2016.08.27	2017.08.26
3	LISN	R&S	NSLK8126	8126487	2016.08.27	2017.08.26
4	RF cables	R&S	R204	R20X	2016.08.27	2017.08.26
5	Attenuator	R&S	ESH3-Z2	143206	2016.08.27	2017.08.26

Radiation test, Band-edge test and 6db bandwidth test equipment

Item	equipment	Manufacturer	Type No.	Serial No.	Last calibration	Calibrated until
1	Spectrum Analyzer (9kHz-26.5GHz)	Agilent	E4407B	MY45108040	2016.08.27	2017.08.26
2	Test Receiver (9kHz-7GHz)	R&S	ESPI	101318	2016.08.27	2017.08.26
3	Bilog Antenna (30MHz-1GHz)	R&S	VULB 9168	VULB91 68-438	2016.08.27	2017.08.26
4	Horn Antenna (1GHz-18GHz)	SCHWARZBECK	BBHA9120D	1201	2016.09.03	2017.09.03
5	Horn Antenna (14GHz-40GHz)	SCHWARZBECK	BBHA 9170	9170-181	2016.09.03	2017.09.03
6	Amplifier (9KHz-6GHz)	SCHWARZBECK	BBV9744	9744-0037	2016.08.27	2017.08.26
7	Amplifier (1GHz-18GHz)	SCHWARZBECK	BBV9718	9718-309	2016.08.27	2017.08.26
8	Amplifier (18GHz-40GHz)	SCHWARZBECK	BBV 9721	9721-205	2016.08.27	2017.08.26
9	Loop Antenna (9KHz-30MHz)	SCHWARZBECK	FMZB1519B	00014	2016.09.03	2017.09.03
10	RF cables1 (9kHz-1GHz)	R&S	R203	R20X	2016.08.27	2017.08.26
11	RF cables2 (1GHz-40GHz)	R&S	R204	R21X	2016.08.27	2017.08.26
12	Antenna connector	Florida RF Labs	N/A	RF 01#	2016.08.27	2017.08.26
13	Power Metter	ANRITSU	ML2487A	6K00001568	2016.08.27	2017.08.26
14	Power Sensor (AV)	ANRITSU	ML2491A	030989	2016.08.27	2017.08.26
15	Signal Analyzer 9kHz-26.5GHz	Agilent	N9010A	MY48030494	2016.08.27	2017.08.26
16	Test Receiver 20kHz-40GHz	R&S	ESU 40	100376	2016.08.27	2017.08.26
17	D.C. Power Supply	LongWei	PS-305D	010964729	2016.08.27	2017.08.26

3. TEST SET-UP AND OPERATION MODES

3.1. Principle of Configuration Selection

Emission: The equipment under test (EUT) was configured to measure its highest possible radiation level. The test modes were adapted accordingly in reference to the Operating Instructions.

3.2. Block Diagram of Test Set-up

Radiated & Conducted Emission Test

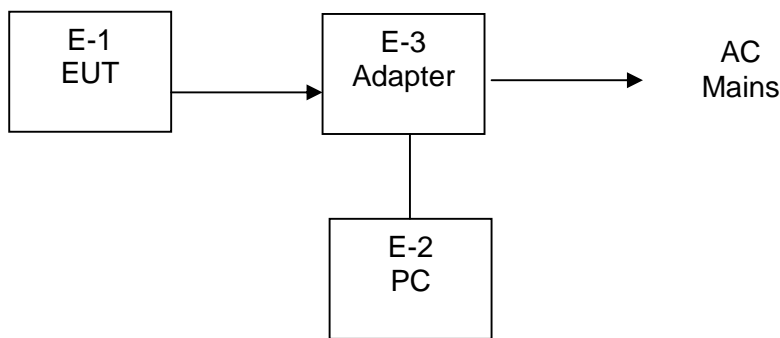

3.3. Special Accessories and Auxiliary Equipment

Item	Equipment	Mfr/Brand	Model/Type No.	Series No.	Note
E-1	Wireless Repeater	N/A	Wireless Repeater	N/A	EUT
E-2	PC (Provide by test lab)	ASUS	AWT8000	N/A	I/P: AC 100-240V 50/60Hz
E-3	Adapter	N/A	G0720-480-050		

Item	Shielded Type	Ferrite Core	Length	Note
C1	NO	NO	1.0m	USB cable

3.4. Countermeasures to Achieve EMC Compliance

None.

3.5. Test Operation Mode and Test Software

None.



4. EMISSION TEST RESULTS

4.1. Conducted Emission Measurement

POWER LINE CONDUCTED EMISSION Limits (Frequency Range 150KHz-30MHz)

FREQUENCY (MHz)	Class B (dBuV)		Standard
	Quasi -peak	Average	
0.15 -0.5	66 - 56 *	56 - 46 *	FCC
0.50 -5.0	56.00	46.00	FCC
5.0 -30.0	60.00	50.00	FCC

Note:

- (1) The tighter limit applies at the band edges.
- (2) The limit of " * " marked band means the limitation decreases linearly with the logarithm of the frequency in the range.

The following table is the setting of the receiver

Receiver Parameters	Setting
Attenuation	10 dB
Start Frequency	0.15 MHz
Stop Frequency	30 MHz
IF Bandwidth	9 kHz

4.1.1. TEST PROCEDURE

- a. The EUT was placed 0.8 meters from the horizontal ground plane with EUT being connected to the power mains through a line impedance stabilization network (LISN). All other support equipments powered from additional LISN(s). The LISN provide 50 Ohm/ 50uH of coupling impedance for the measuring instrument.
- b. Interconnecting cables that hang closer than 40 cm to the ground plane shall be folded back and forth in the center forming a bundle 30 to 40 cm long.
- c. I/O cables that are not connected to a peripheral shall be bundled in the center. The end of the cable may be terminated, if required, using the correct terminating impedance. The overall length shall not exceed 1 m.
- d. LISN at least 80 cm from nearest part of EUT chassis.
- e. For the actual test configuration, please refer to the related Item –EUT Test Photos.

4.1.2. DEVIATION FROM TEST STANDARD

No deviation

4.1.3. TEST SETUP

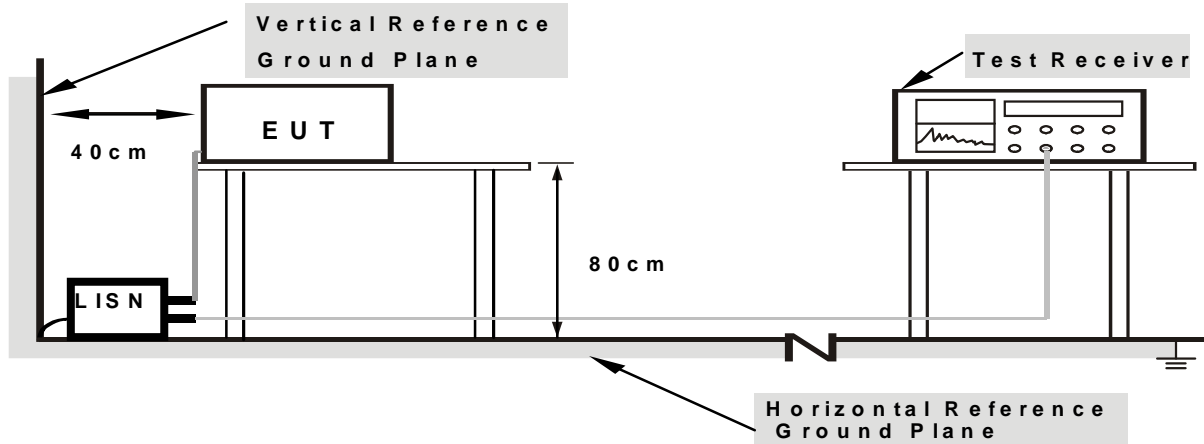

- Note: 1.Support units were connected to second LISN .
2.Both of LISNs (AMN) are 80 cm from EUT and at least 80 from other units and other metal planes

4.1.4. EUT OPERATING CONDITIONS

The EUT was configured for testing in a typical fashion (as a customer would normally use it). The EUT has been programmed to continuously transmit during test. This operating condition was tested and used to collect the included data.

If peak level comply with Quasi-Peak limit, then the Quasi-Peak level is deemed to comply with Quasi-Peak limit.

We pretest AC 120V and AC 240V, the worst voltage was AC 120V and the data recording in the report.

4.1.5. TEST RESULTS



Temperature:	25 °C	Relative Humidity:	54%
Pressure:	1010hPa	Phase :	L
Test Voltage :	AC 120V/60Hz	Test Mode:	Mode 4

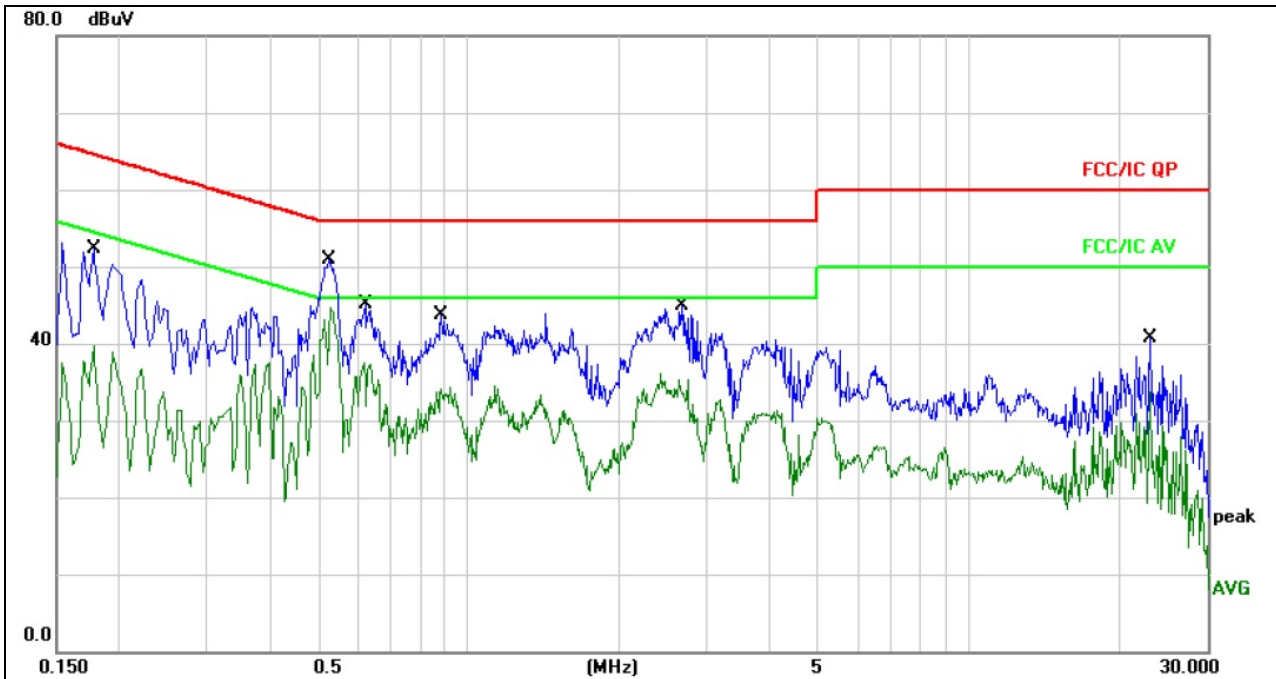

Remark:

1. All readings are Quasi-Peak and Average values.
2. Factor = Insertion Loss + Cable Loss.

No.	Mk.	Freq.	Reading Level	Correct Factor	Measurement	Limit	Over	Detector	Comment
		MHz	dBuV	dB	dBuV	dBuV	dB		
1		0.9820	36.48	10.16	46.64	56.00	-9.36	QP	
2	*	0.9820	35.10	10.16	45.26	46.00	-0.74	AVG	
3		2.9460	36.04	10.19	46.23	56.00	-9.77	QP	
4		2.9460	34.34	10.19	44.53	46.00	-1.47	AVG	
5		4.4180	33.30	10.16	43.46	56.00	-12.54	QP	
6		4.4180	21.35	10.16	31.51	46.00	-14.49	AVG	
7		4.9140	36.20	10.15	46.35	56.00	-9.65	QP	
8		4.9140	34.88	10.15	45.03	46.00	-0.97	AVG	
9		6.8740	34.85	10.10	44.95	60.00	-15.05	QP	
10		6.8740	32.31	10.10	42.41	50.00	-7.59	AVG	
11		8.8380	32.72	10.12	42.84	60.00	-17.16	QP	
12		8.8380	30.95	10.12	41.07	50.00	-8.93	AVG	



Temperature:	25 °C	Relative Humidity:	54%
Pressure:	1010hPa	Phase :	N
Test Voltage :	AC 120V/60Hz	Test Mode:	Mode 4

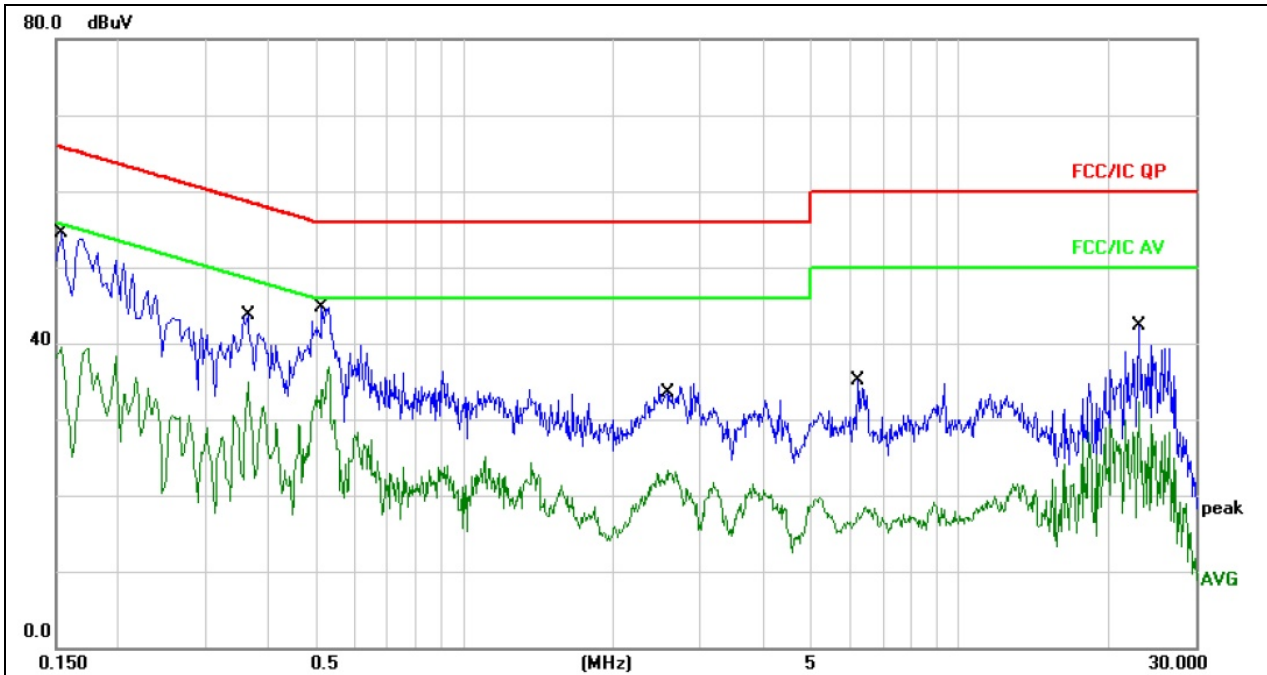

Remark:

1. All readings are Quasi-Peak and Average values.
2. Factor = Insertion Loss + Cable Loss.

No.	Mk.	Freq.	Reading Level	Correct Factor	Measurement	Limit	Over	Detector	Comment
		MHz	dBuV	dB	dBuV	dBuV	dB		
1		0.1539	44.43	10.05	54.48	65.78	-11.30	QP	
2		0.1539	29.46	10.05	39.51	55.78	-16.27	AVG	
3		0.3660	33.53	10.10	43.63	58.59	-14.96	QP	
4		0.3660	24.72	10.10	34.82	48.59	-13.77	AVG	
5		0.5180	34.65	10.12	44.77	56.00	-11.23	QP	
6	*	0.5180	26.81	10.12	36.93	46.00	-9.07	AVG	
7		2.5700	24.47	10.19	34.66	56.00	-21.34	QP	
8		2.5700	13.02	10.19	23.21	46.00	-22.79	AVG	
9		6.2300	25.00	10.09	35.09	60.00	-24.91	QP	
10		6.2300	8.41	10.09	18.50	50.00	-31.50	AVG	
11		23.1299	32.19	10.19	42.38	60.00	-17.62	QP	
12		23.1299	22.17	10.19	32.36	50.00	-17.64	AVG	



4.2. Radiated Emission Measurement

4.2.1. Radiated Emission Limits (Frequency Range 9kHz-1000MHz)

20dBc in any 100 kHz bandwidth outside the operating frequency band. In case the emission fall within the restricted band specified on 15.205(a), then the 15.209(a) limit in the table below has to be followed.

Frequencies (MHz)	Field Strength (micovolts/meter)	Measurement Distance (meters)
0.009~0.490	2400/F(KHz)	300
0.490~1.705	24000/F(KHz)	30
1.705~30.0	30	30
30~88	100	3
88~216	150	3
216~960	200	3
Above 960	500	3

LIMITS OF RADIATED EMISSION MEASUREMENT (Above 1000MHz)

FREQUENCY (MHz)	Class B (dBuV/m) (at 3M)	
	PEAK	AVERAGE
Above 1000	74	54

Notes:

- (1) The limit for radiated test was performed according to FCC PART 15C.
- (2) The tighter limit applies at the band edges.
- (3) Emission level (dBuV/m)=20log Emission level (uV/m).

FREQUENCY RANGE OF RADIATED MEASUREMENT (For unintentional radiators)

Highest frequency generated or Upper frequency of measurement used in the device or on which the device operates or tunes (MHz)	Range (MHz)
Below 1.705	30
1.705 – 108	1000
108 – 500	2000
500 – 1000	5000
Above 1000	5th harmonic of the highest frequency or 40 GHz, whichever is lower

Spectrum Parameter	Setting
Attenuation	Auto
Start Frequency	1000 MHz
Stop Frequency	10th carrier harmonic
RB / VB (emission in restricted band)	1 MHz / 1 MHz for Peak, 1 MHz / 10Hz for Average



Receiver Parameter	Setting
Attenuation	Auto
Start ~ Stop Frequency	9kHz~150kHz / RB 200Hz for QP
Start ~ Stop Frequency	150kHz~30MHz / RB 9kHz for QP
Start ~ Stop Frequency	30MHz~1000MHz / RB 120kHz for QP

4.2.2. TEST PROCEDURE

- a. The EUT was placed on the top of a rotating table 0.8 meters above the ground at a 3 meter semi-anechoic chamber. The table was rotated 360 degrees to determine the position of the highest radiation.
- b. The EUT was set 3 meters away from the interference-receiving antenna, which was mounted on the top of a variable-height antenna tower.
- c. The antenna height is varied from one meter to four meters above the ground to determine the maximum value of the field strength. Both horizontal and vertical polarizations of the antenna are set to make the measurement.
- d. For each suspected emission, the EUT was arranged to its worst case and then the antenna was tuned to heights from 1 meter to 4 meters (for the test frequency of below 30MHz, the antenna was tuned to heights 1 meter) and the rotatable table was turned from 0 degrees to 360 degrees to find the maximum reading.
- e. The test-receiver system was set to Peak Detect Function and Specified Bandwidth with Maximum Hold Mode.
- f. If the emission level of the EUT in peak mode was 10dB lower than the limit specified, then testing could be stopped and the peak values of the EUT would be reported. Otherwise the emissions that did not have 10dB margin would be re-tested one by one using peak, quasi-peak or average method as specified and then reported in a data sheet.

Above 1GHz test procedure as below:

- g. Different between above is the test site, change from Semi- Anechoic Chamber to fully Anechoic Chamber and change form table 0.8 meter to 1.5 meter.
- h Test the EUT in the lowest channel ,the middle channel ,the Highest channel

Note:

Both horizontal and vertical antenna polarities were tested and performed pretest to three orthogonal axis. The worst case emissions were reported

4.2.3. DEVIATION FROM TEST STANDARD

No deviation

4.2.4. TEST SETUP

(A) Radiated Emission Test-Up Frequency Below 30MHz

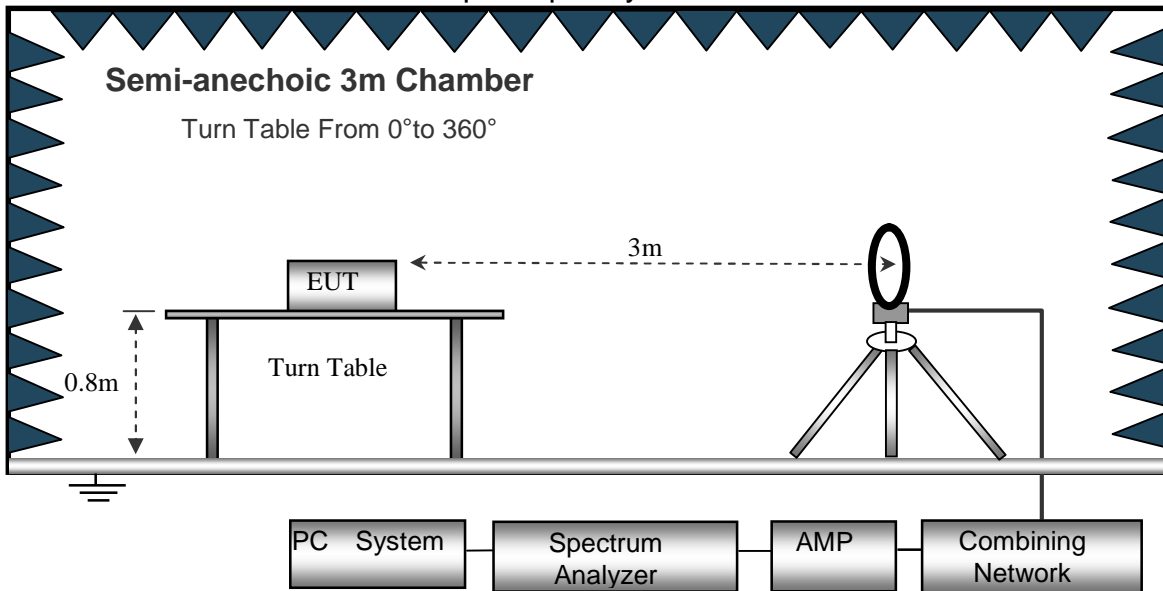

(B) Radiated Emission Test-Up Frequency 30MHz~1GHz

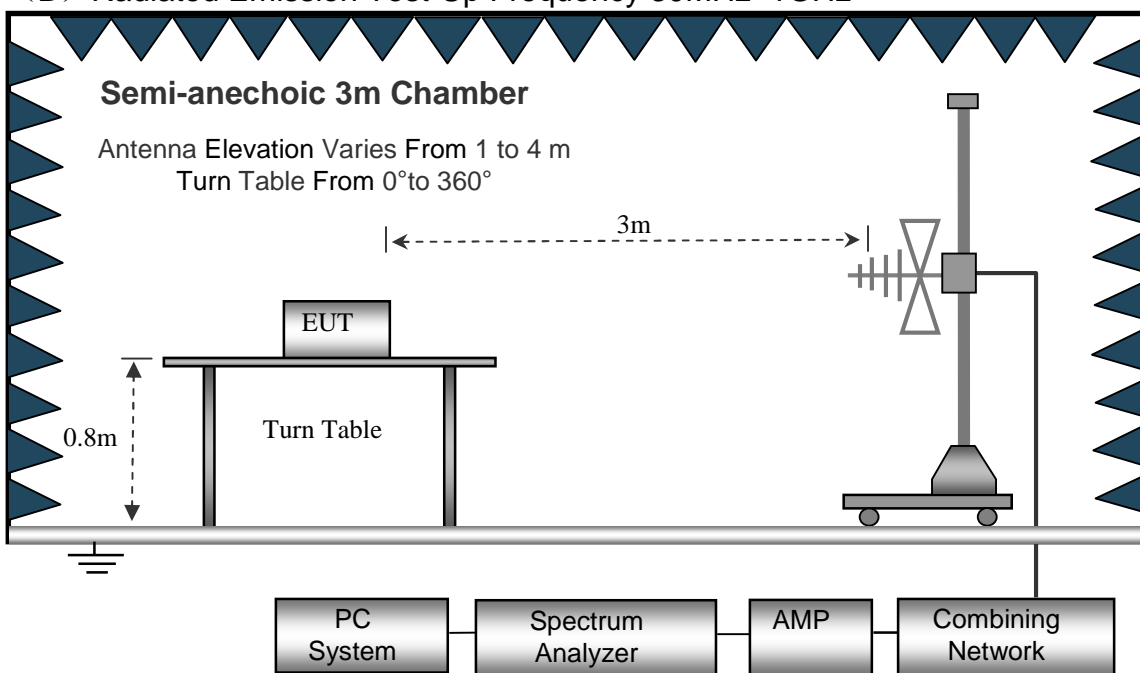

(C) Radiated Emission Test-Up Frequency Above 1GHz

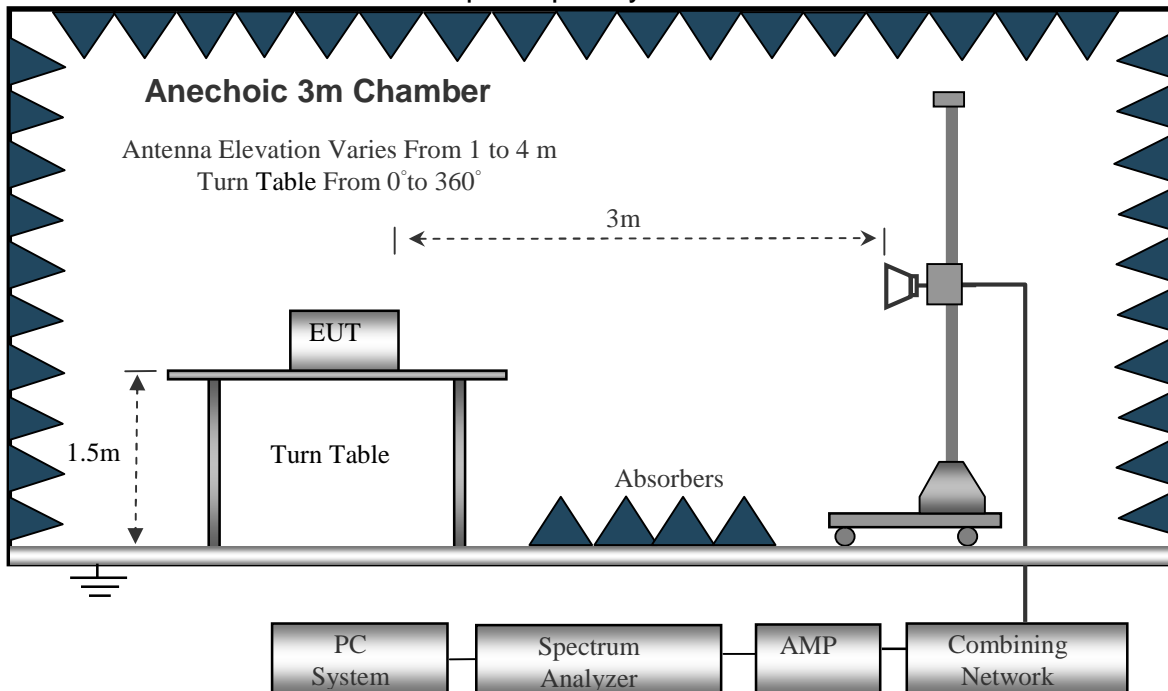

4.2.5. EUT OPERATING CONDITIONS

The EUT tested system was configured as the statements of 2.4 Unless otherwise a special operating condition is specified in the follows during the testing.



Radiated Spurious Emission (Below 30MHz)

Temperature :	20 °C	Relative Humidity :	48%
Pressure :	1010 hPa	Polarization :	---
Test Voltage :	DC 12V from adapter(AC 120V/60Hz)		
Test Mode :	TX		

Freq. (MHz)	Reading (dBuV/m)	Limit (dBuV/m)	Margin (dB)	State P/F
--	--	--	--	PASS
--	--	--	--	PASS

Note:

The amplitude of spurious emissions which are attenuated by more than 20dB below the permissible value has no need to be reported.

Distance extrapolation factor = $40 \log(\text{specific distance}/\text{test distance})$ (dB);

Limit line = specific limits(dBuv) + distance extrapolation factor.



Radiated Spurious Emission (Between 30MHz – 1GHz)

Temperature :	26 °C	Relative Humidity :	54%
Pressure :	1010 hPa	Polarization :	Horizontal
Test Voltage :	DC 12V from adapter(AC 120V/60Hz)		
Test Mode : (Worst)	Link Mode		

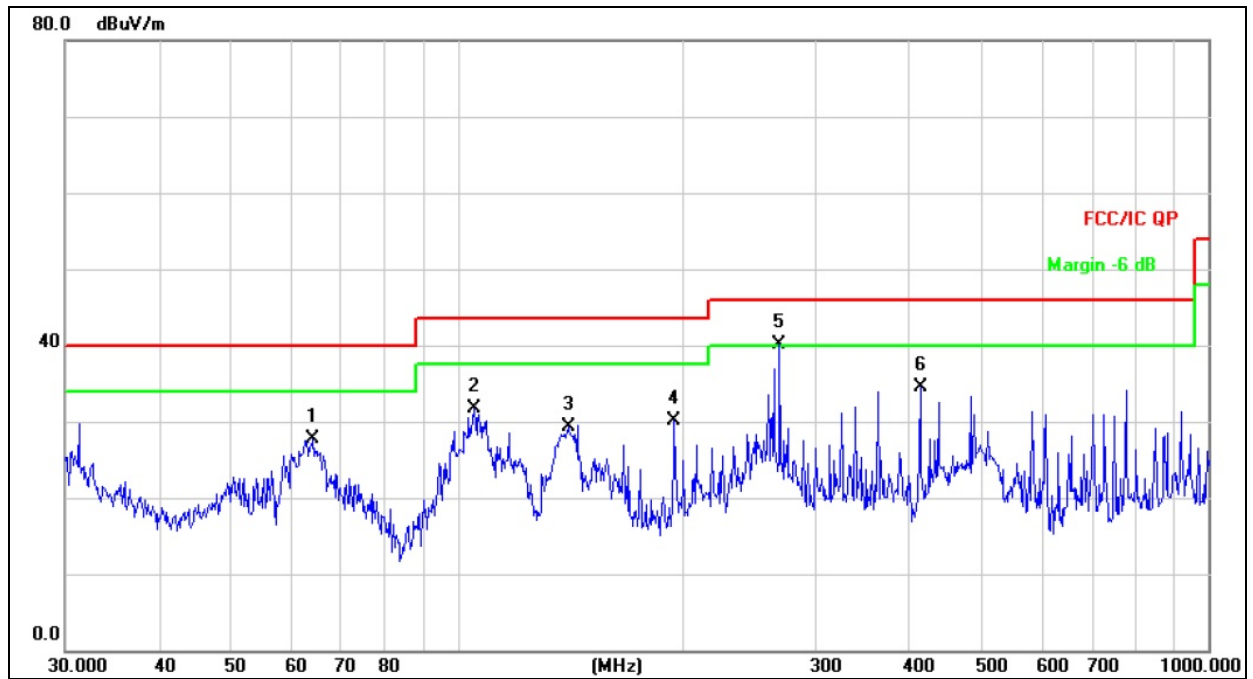

Remark:

Factor = Antenna Factor + Cable Loss – Pre-amplifier.

No.	Mk.	Freq. MHz	Reading Level dBuV	Correct Factor dB/m	Measure- ment dBuV/m	Limit dBuV/m	Over dB	Detector
1		64.2074	40.06	-12.37	27.69	40.00	-12.31	QP
2		105.2718	47.66	-15.99	31.67	43.50	-11.83	QP
3		140.3421	42.69	-13.37	29.32	43.50	-14.18	QP
4		194.4534	45.98	-15.86	30.12	43.50	-13.38	QP
5	*	268.4853	53.74	-13.58	40.16	46.00	-5.84	QP
6		413.2706	44.34	-9.89	34.45	46.00	-11.55	QP



Temperature :	26 °C	Relative Humidity :	54%
Pressure :	1010 hPa	Polarization :	Vertical
Test Voltage :	DC 12V from adapter(AC 120V/60Hz)		
Test Mode : (Worst)	Link Mode		

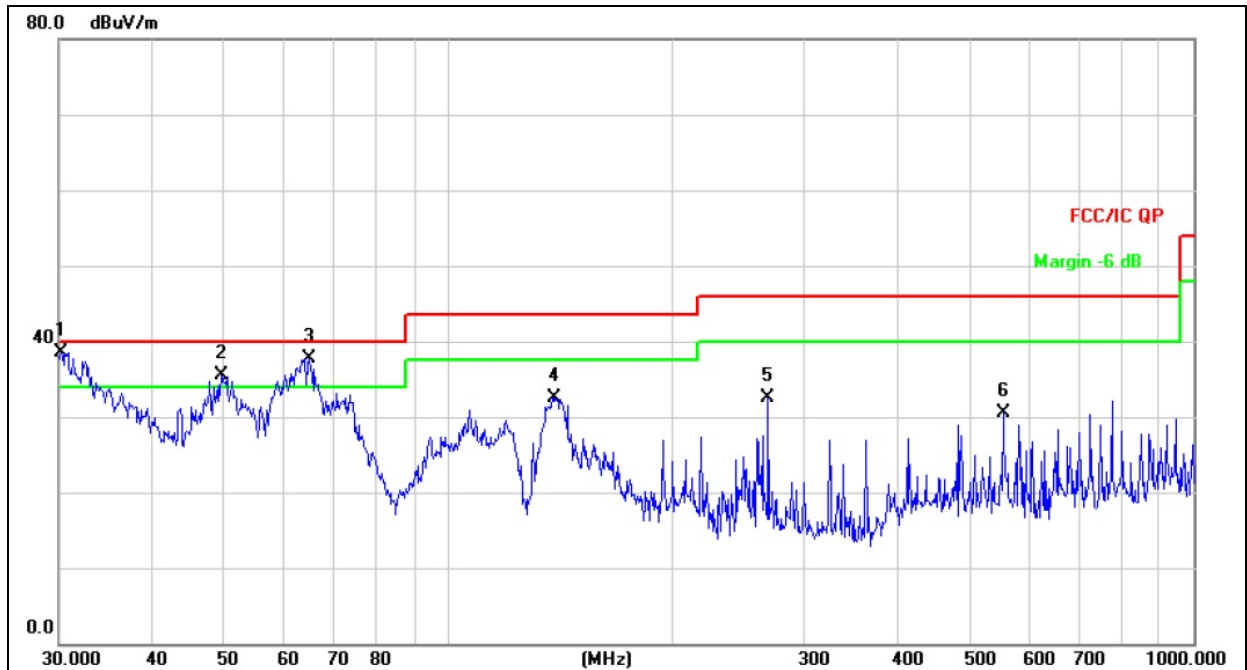

Remark:
Factor = Antenna Factor + Cable Loss – Pre-amplifier.

No.	Mk.	Freq. MHz	Reading Level dBuV	Correct Factor dB/m	Measure- ment dBuV/m	Limit dBuV/m	Over dB	Detector
1	*	30.2110	46.64	-8.05	38.59	40.00	-1.41	QP
2	!	49.5328	45.63	-10.20	35.43	40.00	-4.57	QP
3	!	64.8864	50.18	-12.49	37.69	40.00	-2.31	QP
4		138.3873	46.04	-13.50	32.54	43.50	-10.96	QP
5		268.4852	46.04	-13.58	32.46	46.00	-13.54	QP
6		554.8253	37.37	-6.96	30.41	46.00	-15.59	QP



Radiated Spurious Emission (Above 1GHz)

Polar (H/V)	Frequency	Meter Reading	Pre-amplifier	Cable Loss	Antenna Factor	Emission Level	Limits	Margin	Detector Type
	(MHz)	(dBuV)	(dB)	(dB)	(dB/m)	(dBuV/m)	(dBuV/m)	(dB)	
802.11a Band 1 Operation frequency:5180									
V	10360.00	57.91	39.55	17.85	26.83	63.04	74.00	-10.96	PK
V	10360.00	38.68	39.55	17.85	26.83	43.81	54.00	-10.19	AV
V	15540.00	52.90	38.33	18.63	28.21	61.41	74.00	-12.59	PK
V	15540.00	35.14	38.33	18.63	28.21	43.65	54.00	-10.35	AV
V	25450.00	37.52	37.23	20.36	30.35	51.00	68.20	-17.20	PK
H	10360.00	58.42	39.55	17.85	26.83	63.55	74.00	-10.45	PK
H	10360.00	39.15	39.55	17.85	26.83	44.28	54.00	-9.72	AV
H	15540.00	53.09	38.33	18.63	28.21	61.60	74.00	-12.40	PK
H	15540.00	34.36	38.33	18.63	28.21	42.87	54.00	-11.13	AV
H	25450.00	37.50	37.23	20.36	30.35	50.98	68.20	-17.22	PK
802.11a Band 1 Operation frequency:5200									
V	10400.00	58.24	39.61	17.89	26.89	63.41	74.00	-10.59	PK
V	10400.00	39.36	39.61	17.89	26.89	44.53	54.00	-9.47	AV
V	15600.00	53.29	38.47	18.67	28.27	61.76	74.00	-12.24	PK
V	15600.00	34.92	38.47	18.67	28.27	43.39	54.00	-10.61	AV
V	25450.00	38.01	37.23	20.36	30.35	51.49	68.20	-16.71	PK
H	10400.00	57.56	39.61	17.89	26.89	62.73	74.00	-11.27	PK
H	10400.00	38.23	39.61	17.89	26.89	43.40	54.00	-10.60	AV
H	15600.00	52.90	38.47	18.67	28.27	61.37	74.00	-12.63	PK
H	15600.00	34.48	38.47	18.67	28.27	42.95	54.00	-11.05	AV
H	25450.00	38.39	37.23	20.36	30.35	51.87	68.20	-16.33	PK
802.11a Band 1 Operation frequency:5240									
V	10480.00	57.42	39.69	17.93	26.94	62.60	74.00	-11.40	PK
V	10480.00	39.09	39.69	17.93	26.94	44.27	54.00	-9.73	AV
V	15720.00	52.83	38.53	18.73	28.32	61.35	74.00	-12.65	PK
V	15720.00	34.67	38.53	18.73	28.32	43.19	54.00	-10.81	AV
V	25450.00	37.79	37.23	20.36	30.35	51.27	68.20	-16.93	PK
H	10480.00	57.31	39.69	17.93	26.94	62.49	74.00	-11.51	PK
H	10480.00	39.69	39.69	17.93	26.94	44.87	54.00	-9.13	AV
H	15720.00	52.74	38.53	18.73	28.32	61.26	74.00	-12.74	PK
H	15720.00	34.57	38.53	18.73	28.32	43.09	54.00	-10.91	AV
H	25450.00	36.69	37.23	20.36	30.35	50.17	68.20	-18.03	PK
<p>Remark:</p> <p>1. Emission Level = Meter Reading + Antenna Factor + Cable Loss – Pre-amplifier, Margin= Emission Level - Limit</p> <p>2. If peak below the average limit, the average emission was no test.</p> <p>3. The amplitude of spurious emissions which are attenuated by more than 20dB below the permissible value has no need to be reported.</p>									



Polar (H/V)	Frequency	Meter Reading	Pre-amplifier	Cable Loss	Antenna Factor	Emission Level	Limits	Margin	Detector Type
	(MHz)	(dBuV)	(dB)	(dB)	(dB/m)	(dBuV/m)	(dBuV/m)	(dB)	
802.11n(HT20) Band 1 Operation frequency:5180									
V	10360.00	57.57	39.55	17.85	26.83	62.70	74.00	-11.30	PK
V	10360.00	38.46	39.55	17.85	26.83	43.59	54.00	-10.41	AV
V	15540.00	52.60	38.33	18.63	28.21	61.11	74.00	-12.89	PK
V	15540.00	34.94	38.33	18.63	28.21	43.45	54.00	-10.55	AV
V	25450.00	37.95	37.23	20.36	30.35	51.43	68.20	-16.77	PK
H	10360.00	58.09	39.55	17.85	26.83	63.22	74.00	-10.78	PK
H	10360.00	39.93	39.55	17.85	26.83	45.06	54.00	-8.94	AV
H	15540.00	52.79	38.33	18.63	28.21	61.30	74.00	-12.70	PK
H	15540.00	34.17	38.33	18.63	28.21	42.68	54.00	-11.32	AV
H	25450.00	37.29	37.23	20.36	30.35	50.77	68.20	-17.43	PK
802.11n(HT20) Band 1 Operation frequency:5200									
V	10400.00	57.91	39.61	17.89	26.89	63.08	74.00	-10.92	PK
V	10400.00	39.14	39.61	17.89	26.89	44.31	54.00	-9.69	AV
V	15600.00	52.99	38.47	18.67	28.27	61.46	74.00	-12.54	PK
V	15600.00	34.72	38.47	18.67	28.27	43.19	54.00	-10.81	AV
V	25450.00	37.74	37.23	20.36	30.35	51.22	68.20	-16.98	PK
H	10400.00	58.24	39.61	17.89	26.89	63.41	74.00	-10.59	PK
H	10400.00	39.02	39.61	17.89	26.89	44.19	54.00	-9.81	AV
H	15600.00	52.60	38.47	18.67	28.27	61.07	74.00	-12.93	PK
H	15600.00	34.28	38.47	18.67	28.27	42.75	54.00	-11.25	AV
H	25450.00	37.14	37.23	20.36	30.35	50.62	68.20	-17.58	PK
802.11n(HT20) Band 1 Operation frequency:5240									
V	10480.00	57.66	39.69	17.93	26.94	62.84	74.00	-11.16	PK
V	10480.00	38.24	39.69	17.93	26.94	43.42	54.00	-10.58	AV
V	15720.00	53.04	38.53	18.73	28.32	61.56	74.00	-12.44	PK
V	15720.00	34.81	38.53	18.73	28.32	43.33	54.00	-10.67	AV
V	25450.00	37.98	37.23	20.36	30.35	51.46	68.20	-16.74	PK
H	10480.00	57.54	39.69	17.93	26.94	62.72	74.00	-11.28	PK
H	10480.00	38.85	39.69	17.93	26.94	44.03	54.00	-9.97	AV
H	15720.00	52.95	38.53	18.73	28.32	61.47	74.00	-12.53	PK
H	15720.00	34.71	38.53	18.73	28.32	43.23	54.00	-10.77	AV
H	25450.00	37.83	37.23	20.36	30.35	51.31	68.20	-16.89	PK
<p>Remark:</p> <p>1. Emission Level = Meter Reading + Antenna Factor + Cable Loss – Pre-amplifier, Margin= Emission Level - Limit</p> <p>2. If peak below the average limit, the average emission was no test.</p> <p>3. The amplitude of spurious emissions which are attenuated by more than 20dB below the permissible value has no need to be reported.</p>									



Polar (H/V)	Frequency	Meter Reading	Pre-amplifier	Cable Loss	Antenna Factor	Emission Level	Limits	Margin	Detector Type
	(MHz)	(dBuV)	(dB)	(dB)	(dB/m)	(dBuV/m)	(dBuV/m)	(dB)	
802.11n(HT40) Band 1 Operation frequency:5190									
V	10380.00	57.62	39.55	17.85	26.83	62.75	74.00	-11.25	PK
V	10380.00	38.49	39.55	17.85	26.83	43.62	54.00	-10.38	AV
V	15570.00	52.64	38.33	18.63	28.21	61.15	74.00	-12.85	PK
V	15570.00	33.96	38.33	18.63	28.21	42.47	54.00	-11.53	AV
V	25450.00	37.99	37.23	20.36	30.35	51.47	68.20	-16.73	PK
H	10380.00	58.14	39.55	17.85	26.83	63.27	74.00	-10.73	PK
H	10380.00	38.96	39.55	17.85	26.83	44.09	54.00	-9.91	AV
H	15570.00	52.83	38.33	18.63	28.21	61.34	74.00	-12.66	PK
H	15570.00	35.20	38.33	18.63	28.21	43.71	54.00	-10.29	AV
H	25450.00	37.26	37.23	20.36	30.35	50.74	68.20	-17.46	PK
802.11n(HT40) Band 1 Operation frequency:5230									
V	10460.00	57.60	39.69	17.93	26.94	62.78	74.00	-11.22	PK
V	10460.00	38.88	39.69	17.93	26.94	44.06	54.00	-9.94	AV
V	15690.00	52.99	38.53	18.73	28.32	61.51	74.00	-12.49	PK
V	15690.00	33.73	38.53	18.73	28.32	42.25	54.00	-11.75	AV
V	25450.00	37.78	37.23	20.36	30.35	51.26	68.20	-16.94	PK
H	10460.00	57.60	39.69	17.93	26.94	62.78	74.00	-11.22	PK
H	10460.00	38.88	39.69	17.93	26.94	44.06	54.00	-9.94	AV
H	15690.00	52.99	38.53	18.73	28.32	61.51	74.00	-12.49	PK
H	15690.00	34.74	38.53	18.73	28.32	43.26	54.00	-10.74	AV
H	25450.00	38.17	37.23	20.36	30.35	51.65	68.20	-16.55	PK
<p>Remark:</p> <p>1. Emission Level = Meter Reading + Antenna Factor + Cable Loss – Pre-amplifier, Margin= Emission Level - Limit</p> <p>2. If peak below the average limit, the average emission was no test.</p> <p>3. The amplitude of spurious emissions which are attenuated by more than 20dB below the permissible value has no need to be reported.</p>									



Polar (H/V)	Frequency	Meter Reading	Pre-amplifier	Cable Loss	Antenna Factor	Emission Level	Limits	Margin	Detector Type
	(MHz)	(dBuV)	(dB)	(dB)	(dB/m)	(dBuV/m)	(dBuV/m)	(dB)	
802.11a Band 4 Operation frequency:5745									
V	11490.00	57.71	39.73	18.19	27.31	63.48	74.00	-10.52	PK
V	11490.00	38.55	39.73	18.19	27.31	44.32	54.00	-9.68	AV
V	17235.00	53.73	38.59	18.92	28.41	62.47	74.00	-11.53	PK
V	17235.00	34.02	38.59	18.92	28.41	42.76	54.00	-11.24	AV
V	25450.00	37.56	37.23	20.36	30.35	51.04	68.20	-17.16	PK
H	11490.00	58.23	39.73	18.19	27.31	64.00	74.00	-10.00	PK
H	11490.00	39.02	39.73	18.19	27.31	44.79	54.00	-9.21	AV
H	17235.00	53.92	38.59	18.92	28.41	62.66	74.00	-11.34	PK
H	17235.00	34.25	38.59	18.92	28.41	42.99	54.00	-11.01	AV
H	25450.00	37.33	37.23	20.36	30.35	50.81	68.20	-17.39	PK
802.11a Band 4 Operation frequency:5785									
V	11570.00	58.05	39.76	18.25	27.39	63.93	74.00	-10.07	PK
V	11570.00	39.23	39.76	18.25	27.39	45.11	54.00	-8.89	AV
V	17355.00	54.12	38.62	19.16	28.48	63.14	74.00	-10.86	PK
V	17355.00	33.79	38.62	19.16	28.48	42.81	54.00	-11.19	AV
V	25450.00	37.85	37.23	20.36	30.35	51.33	68.20	-16.87	PK
H	11570.00	57.36	39.76	18.25	27.39	63.24	74.00	-10.76	PK
H	11570.00	39.11	39.76	18.25	27.39	44.99	54.00	-9.01	AV
H	17355.00	53.73	38.62	19.16	28.48	62.75	74.00	-11.25	PK
H	17355.00	34.36	38.62	19.16	28.48	43.38	54.00	-10.62	AV
H	25450.00	38.23	37.23	20.36	30.35	51.71	68.20	-16.49	PK
802.11a Band 4 Operation frequency:5825									
V	11650.00	57.80	39.79	18.32	27.42	63.75	74.00	-10.25	PK
V	11650.00	38.33	39.79	18.32	27.42	44.28	54.00	-9.72	AV
V	17475.00	54.17	38.66	19.24	28.53	63.28	74.00	-10.72	PK
V	17475.00	33.88	38.66	19.24	28.53	42.99	54.00	-11.01	AV
V	25450.00	38.09	37.23	20.36	30.35	51.57	68.20	-16.63	PK
H	11650.00	57.69	39.79	18.32	27.42	63.64	74.00	-10.36	PK
H	11650.00	38.94	39.79	18.32	27.42	44.89	54.00	-9.11	AV
H	17475.00	53.08	38.66	19.24	28.53	62.19	74.00	-11.81	PK
H	17475.00	33.78	38.66	19.24	28.53	42.89	54.00	-11.11	AV
H	25450.00	38.00	37.23	20.36	30.35	51.48	68.20	-16.72	PK

Remark:

1. Emission Level = Meter Reading + Antenna Factor + Cable Loss – Pre-amplifier, Margin= Emission Level - Limit
2. If peak below the average limit, the average emission was no test.
3. The amplitude of spurious emissions which are attenuated by more than 20dB below the permissible value has no need to be reported.



Polar (H/V)	Frequency	Meter Reading	Pre-amplifier	Cable Loss	Antenna Factor	Emission Level	Limits	Margin	Detector Type
	(MHz)	(dBuV)	(dB)	(dB)	(dB/m)	(dBuV/m)	(dBuV/m)	(dB)	
802.11n(HT20) Band 4 Operation frequency:5745									
V	11490.00	57.78	39.73	18.19	27.31	63.55	74.00	-10.45	PK
V	11490.00	38.60	39.73	18.19	27.31	44.37	54.00	-9.63	AV
V	17235.00	53.80	38.59	18.92	28.41	62.54	74.00	-11.46	PK
V	17235.00	35.07	38.59	18.92	28.41	43.81	54.00	-10.19	AV
V	25450.00	38.12	37.23	20.36	30.35	51.60	68.20	-16.60	PK
H	11490.00	58.30	39.73	18.19	27.31	64.07	74.00	-9.93	PK
H	11490.00	39.07	39.73	18.19	27.31	44.84	54.00	-9.16	AV
H	17235.00	53.99	38.59	18.92	28.41	62.73	74.00	-11.27	PK
H	17235.00	34.29	38.59	18.92	28.41	43.03	54.00	-10.97	AV
H	25450.00	37.40	37.23	20.36	30.35	50.88	68.20	-17.32	PK
802.11n(HT20) Band 4 Operation frequency:5785									
V	11570.00	58.12	39.76	18.25	27.39	64.00	74.00	-10.00	PK
V	11570.00	38.27	39.76	18.25	27.39	44.15	54.00	-9.85	AV
V	17355.00	54.19	38.62	19.16	28.48	63.21	74.00	-10.79	PK
V	17355.00	34.85	38.62	19.16	28.48	43.87	54.00	-10.13	AV
V	25450.00	37.91	37.23	20.36	30.35	51.39	68.20	-16.81	PK
H	11570.00	58.45	39.76	18.25	27.39	64.33	74.00	-9.67	PK
H	11570.00	39.16	39.76	18.25	27.39	45.04	54.00	-8.96	AV
H	17355.00	53.80	38.62	19.16	28.48	62.82	74.00	-11.18	PK
H	17355.00	34.40	38.62	19.16	28.48	43.42	54.00	-10.58	AV
H	25450.00	38.29	37.23	20.36	30.35	51.77	68.20	-16.43	PK
802.11n(HT20) Band 4 Operation frequency:5825									
V	11650.00	57.88	39.79	18.32	27.42	63.83	74.00	-10.17	PK
V	11650.00	38.38	39.79	18.32	27.42	44.33	54.00	-9.67	AV
V	17475.00	54.24	38.66	19.24	28.53	63.35	74.00	-10.65	PK
V	17475.00	34.94	38.66	19.24	28.53	44.05	54.00	-9.95	AV
V	25450.00	38.15	37.23	20.36	30.35	51.63	68.20	-16.57	PK
H	11650.00	57.76	39.79	18.32	27.42	63.71	74.00	-10.29	PK
H	11650.00	38.99	39.79	18.32	27.42	44.94	54.00	-9.06	AV
H	17475.00	54.15	38.66	19.24	28.53	63.26	74.00	-10.74	PK
H	17475.00	34.84	38.66	19.24	28.53	43.95	54.00	-10.05	AV
H	25450.00	39.07	37.23	20.36	30.35	52.55	68.20	-15.65	PK

Remark:

1. Emission Level = Meter Reading + Antenna Factor + Cable Loss – Pre-amplifier, Margin= Emission Level - Limit
2. If peak below the average limit, the average emission was no test.
3. The amplitude of spurious emissions which are attenuated by more than 20dB below the permissible value has no need to be reported.



Polar (H/V)	Frequency	Meter Reading	Pre-amplifier	Cable Loss	Antenna Factor	Emission Level	Limits	Margin	Detector Type
	(MHz)	(dBuV)	(dB)	(dB)	(dB/m)	(dBuV/m)	(dBuV/m)	(dB)	
802.11n(HT40) Band 4 Operation frequency:5755									
V	11510.00	57.54	39.73	18.19	27.31	63.31	74.00	-10.69	PK
V	11510.00	38.45	39.73	18.19	27.31	44.22	54.00	-9.78	AV
V	17265.00	53.58	38.59	18.92	28.41	62.32	74.00	-11.68	PK
V	17265.00	32.91	38.59	18.92	28.41	41.65	54.00	-12.35	AV
V	25450.00	37.93	37.23	20.36	30.35	51.41	68.20	-16.79	PK
H	11510.00	58.07	39.73	18.19	27.31	63.84	74.00	-10.16	PK
H	11510.00	38.91	39.73	18.19	27.31	44.68	54.00	-9.32	AV
H	17265.00	53.77	38.59	18.92	28.41	62.51	74.00	-11.49	PK
H	17265.00	34.15	38.59	18.92	28.41	42.89	54.00	-11.11	AV
H	25450.00	37.20	37.23	20.36	30.35	50.68	68.20	-17.52	PK
802.11n(HT40) Band 4 Operation frequency:5795									
V	11590.00	57.89	39.76	18.25	27.39	63.77	74.00	-10.23	PK
V	11590.00	39.12	39.76	18.25	27.39	45.00	54.00	-9.00	AV
V	17385.00	53.97	38.62	19.16	28.48	62.99	74.00	-11.01	PK
V	17385.00	33.70	38.62	19.16	28.48	42.72	54.00	-11.28	AV
V	25450.00	37.72	37.23	20.36	30.35	51.20	68.20	-17.00	PK
H	11590.00	58.22	39.76	18.25	27.39	64.10	74.00	-9.90	PK
H	11590.00	38.00	39.76	18.25	27.39	43.88	54.00	-10.12	AV
H	17385.00	53.58	38.62	19.16	28.48	62.60	74.00	-11.40	PK
H	17385.00	34.26	38.62	19.16	28.48	43.28	54.00	-10.72	AV
H	25450.00	38.10	37.23	20.36	30.35	51.58	68.20	-16.62	PK
<p>Remark:</p> <p>1. Emission Level = Meter Reading + Antenna Factor + Cable Loss – Pre-amplifier, Margin= Emission Level - Limit</p> <p>2. If peak below the average limit, the average emission was no test.</p> <p>3. The amplitude of spurious emissions which are attenuated by more than 20dB below the permissible value has no need to be reported.</p>									



Radiation in restricted band

Polar (H/V)	Frequency	Meter Reading	Pre-amplifier	Cable Loss	Antenna Factor	Emission Level	Limits	Margin	Detector Type
	(MHz)	(dBuV)	(dB)	(dB)	(dB/m)	(dBuV/m)	(dBuV/m)	(dB)	
802.11a Band 1 Operation frequency:5180									
V	4500.00	62.37	39.37	7.68	25.76	56.44	74.00	-17.56	PK
V	4500.00	49.85	39.37	7.68	25.76	43.92	54.00	-10.08	AV
V	5150.00	66.46	38.76	7.92	26.38	62.00	74.00	-12.00	PK
V	5150.00	54.42	38.76	7.92	26.38	49.96	54.00	-4.04	AV
H	4500.00	61.87	39.37	7.68	25.76	55.94	74.00	-18.06	PK
H	4500.00	50.33	39.37	7.68	25.76	44.40	54.00	-9.60	AV
H	5150.00	66.65	38.76	7.92	26.38	62.19	74.00	-11.81	PK
H	5150.00	52.66	38.76	7.92	26.38	48.20	54.00	-5.80	AV
802.11a Band 1 Operation frequency:5240									
V	5350.00	65.97	39.74	7.97	25.87	60.07	74.00	-13.93	PK
V	5350.00	53.34	39.74	7.97	25.87	47.44	54.00	-6.56	AV
V	5460.00	62.29	39.78	8.06	25.92	56.49	74.00	-17.51	PK
V	5460.00	50.86	39.78	8.06	25.92	45.06	54.00	-8.94	AV
H	5350.00	65.85	39.74	7.97	25.87	59.95	74.00	-14.05	PK
H	5350.00	52.93	39.74	7.97	25.87	47.03	54.00	-6.97	AV
H	5460.00	62.20	39.78	8.06	25.92	56.40	74.00	-17.60	PK
H	5460.00	51.78	39.78	8.06	25.92	45.98	54.00	-8.02	AV

802.11n(HT20) Band 1 Operation frequency:5180									
V	4500.00	62.02	39.37	7.68	25.76	56.09	74.00	-17.91	PK
V	4500.00	51.67	39.37	7.68	25.76	45.74	54.00	-8.26	AV
V	5150.00	65.13	38.76	7.92	26.38	60.67	74.00	-13.33	PK
V	5150.00	55.23	38.76	7.92	26.38	50.77	54.00	-3.23	AV
H	4500.00	61.53	39.37	7.68	25.76	55.60	74.00	-18.40	PK
H	4500.00	51.13	39.37	7.68	25.76	45.20	54.00	-8.80	AV
H	5150.00	65.32	38.76	7.92	26.38	60.86	74.00	-13.14	PK
H	5150.00	53.47	38.76	7.92	26.38	49.01	54.00	-4.99	AV
802.11n(HT20) Band 1 Operation frequency: 5240									
V	5350.00	65.19	39.74	7.97	25.87	59.29	74.00	-14.71	PK
V	5350.00	55.54	39.74	7.97	25.87	49.64	54.00	-4.36	AV
V	5460.00	61.48	39.78	8.06	25.92	55.68	74.00	-18.32	PK
V	5460.00	51.01	39.78	8.06	25.92	45.21	54.00	-8.79	AV
H	5350.00	65.06	39.74	7.97	25.87	59.16	74.00	-14.84	PK
H	5350.00	53.09	39.74	7.97	25.87	47.19	54.00	-6.81	AV
H	5460.00	62.41	39.78	8.06	25.92	56.61	74.00	-17.39	PK
H	5460.00	50.90	39.78	8.06	25.92	45.10	54.00	-8.90	AV

Remark:

1. Emission Level = Meter Reading + Antenna Factor + Cable Loss – Pre-amplifier,
Margin= Emission Level - Limit

2. The amplitude of spurious emissions which are attenuated by more than 20dB below the permissible value has no need to be reported.



Polar (H/V)	Frequency	Meter Reading	Pre-amplifier	Cable Loss	Antenna Factor	Emission Level	Limits	Margin	Detector Type
	(MHz)	(dBuV)	(dB)	(dB)	(dB/m)	(dBuV/m)	(dBuV/m)	(dB)	
802.11n(HT40) Band 1 Operation frequency:5190									
V	4500.00	62.07	39.37	7.68	25.76	56.14	74.00	-17.86	PK
V	4500.00	52.73	39.37	7.68	25.76	46.80	54.00	-7.20	AV
V	5150.00	65.17	38.76	7.92	26.38	60.71	74.00	-13.29	PK
V	5150.00	54.23	38.76	7.92	26.38	49.77	54.00	-4.23	AV
H	4500.00	61.58	39.37	7.68	25.76	55.65	74.00	-18.35	PK
H	4500.00	51.16	39.37	7.68	25.76	45.23	54.00	-8.77	AV
H	5150.00	65.36	38.76	7.92	26.38	60.90	74.00	-13.10	PK
H	5150.00	53.45	38.76	7.92	26.38	48.99	54.00	-5.01	AV
802.11n(HT40) Band 1 Operation frequency:5230									
V	5350.00	65.13	39.74	7.97	25.87	59.23	74.00	-14.77	PK
V	5350.00	56.20	39.74	7.97	25.87	50.30	54.00	-3.70	AV
V	5460.00	61.43	39.78	8.06	25.92	55.63	74.00	-18.37	PK
V	5460.00	50.92	39.78	8.06	25.92	45.12	54.00	-8.88	AV
H	5350.00	64.10	39.74	7.97	25.87	58.20	74.00	-15.80	PK
H	5350.00	54.15	39.74	7.97	25.87	48.25	54.00	-5.75	AV
H	5460.00	61.19	39.78	8.06	25.92	55.39	74.00	-18.61	PK
H	5460.00	51.96	39.78	8.06	25.92	46.16	54.00	-7.84	AV
<p>Remark:</p> <p>1. Emission Level = Meter Reading + Antenna Factor + Cable Loss – Pre-amplifier, Margin= Emission Level - Limit</p> <p>2. The amplitude of spurious emissions which are attenuated by more than 20dB below the permissible value has no need to be reported.</p>									



5. BAND EDGE COMPLIANCE TEST

5.1. Limits

(1) For transmitters operating in the 5.15-5.25 GHz band: All emissions outside of the 5.15-5.35 GHz band shall not exceed an e.i.r.p. of -27 dBm/MHz.

(4) For transmitters operating in the 5.725-5.85 GHz band: All emissions shall be limited to a level of -27 dBm/MHz at 75 MHz or more above or below the band edge increasing linearly to 10 dBm/MHz at 25 MHz above or below the band edge, and from 25 MHz above or below the band edge increasing linearly to a level of 15.6 dBm/MHz at 5 MHz above or below the band edge, and from 5 MHz above or below the band edge increasing linearly to a level of 27 dBm/MHz at the band edge.

5.2. TEST PROCEDURE

1. Check the calibration of the measuring instrument using either an internal calibrator or a known signal from an external generator.
2. Position the EUT without connection to measurement instrument. Turn on the EUT and connect its antenna terminal to measurement instrument via a low loss cable. Then set it to any one measured frequency within its operating range, and make sure the instrument is operated in its linear range.
3. Set RBW of spectrum analyzer to 1 MHz with a convenient frequency span.
4. Measure the highest amplitude appearing on spectral display and set it as a reference level. Plot the graph with marking the highest point and edge frequency.
5. Repeat above procedures until all measured frequencies were complete.

5.3. Test Data

Please see data as below:



Band 1
802.11a



802.11n20

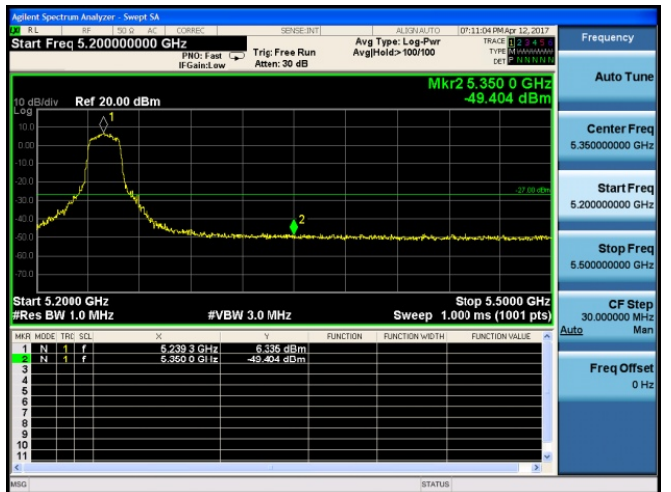
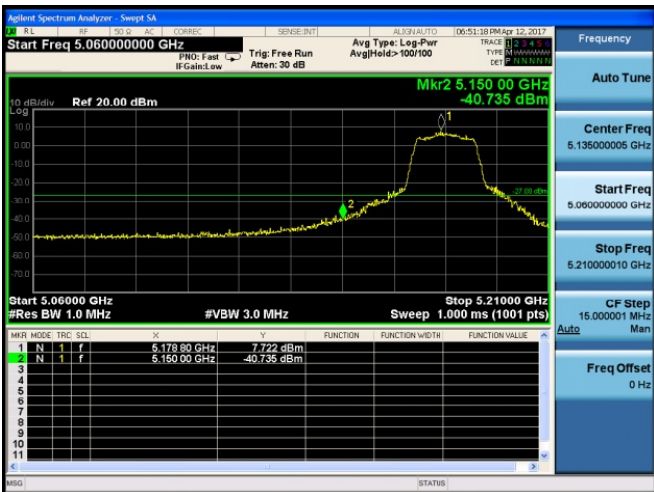

802.11n40

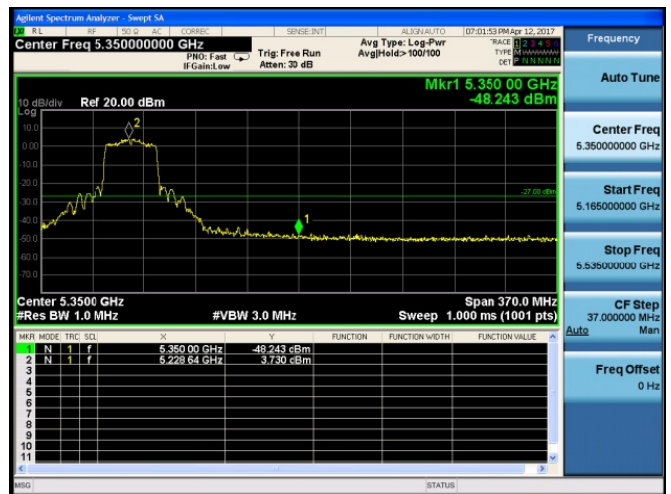



Band 4
802.11a

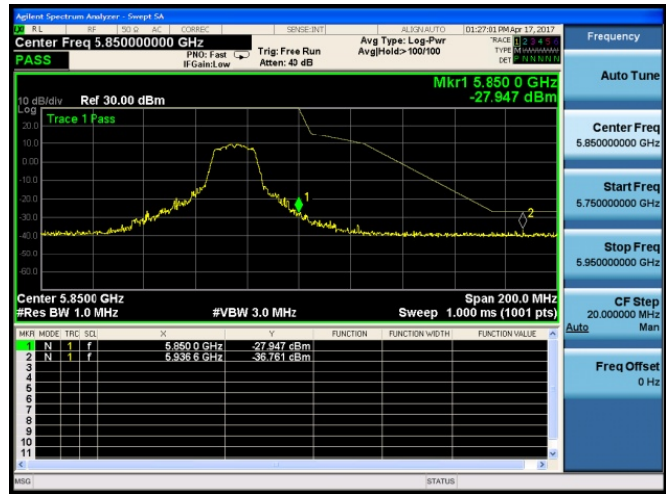
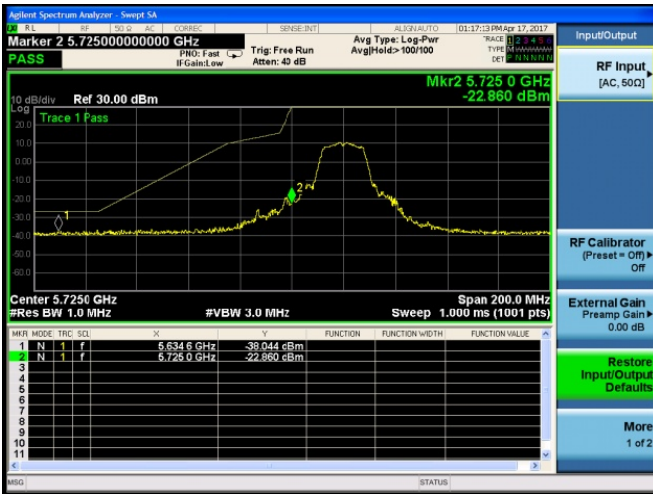

802.11n20

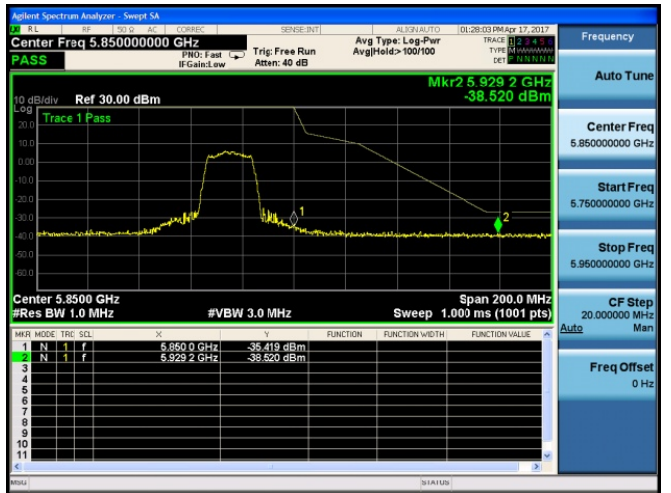
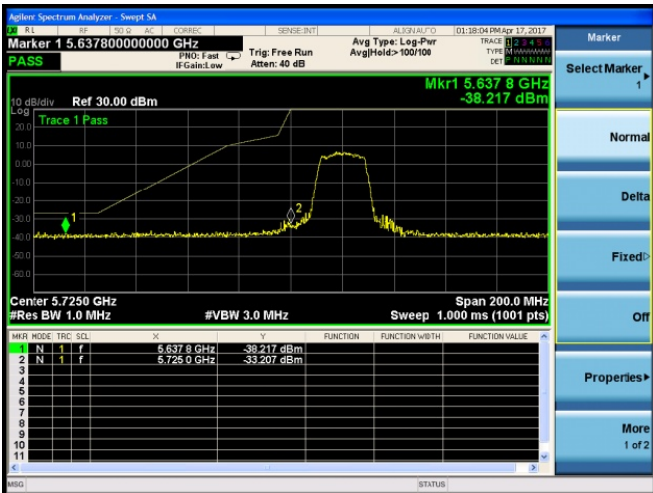

802.11n40

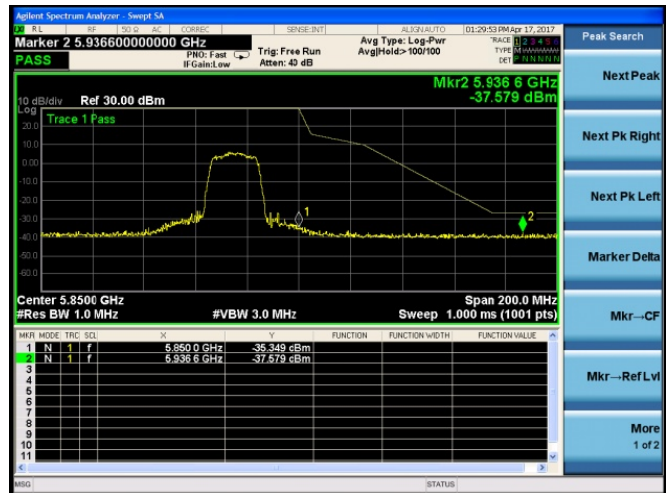
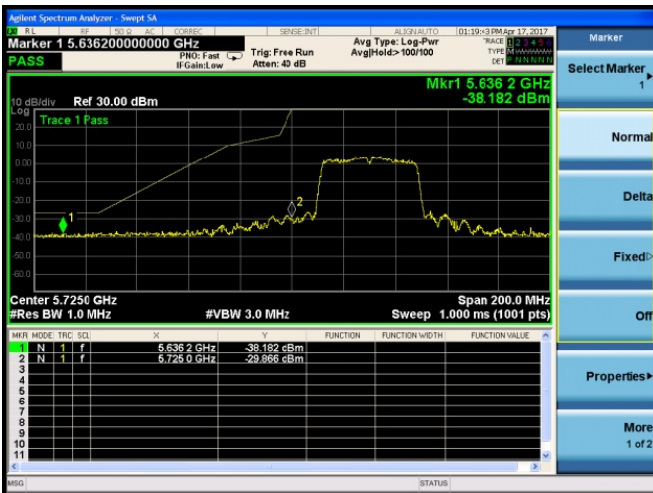



6. 26DB AND 99% BANDWIDTH TEST

6.1. Limit

The bandwidth at 26 dB down from the highest in-band spectral density is measured with a spectrum analyzer connected to the antenna terminal while the EUT is operating at its maximum power control level, as defined in KDB 789033, at the appropriate frequencies. The spectrum analyzer's bandwidth measurement function is configured to measure the 26 dB bandwidth.

The 26 dB bandwidth is used to determine the conducted power limits.

There is no limit bandwidth for U-NII-1, U-NII-2-A and U-NII-2-C.

The minimum of 6dB Bandwidth measurement is 0.5 MHz for U-NII-3

6.2. Test setup

- a) Set RBW = approximately 1% of the emission bandwidth.
- b) Set the VBW > RBW.
- c) Detector = Peak.
- d) Trace mode = max hold.
- e) Measure the maximum width of the emission that is 26 dB down from the maximum of the emission. Compare this with the RBW setting of the analyzer. Readjust RBW and repeat measurement as needed until the RBW/EBW ratio is approximately 1%.

The following procedure shall be used for measuring (99 %) power bandwidth:

1. Set center frequency to the nominal EUT channel center frequency.
2. Set span = 1.5 times to 5.0 times the OBW.
3. Set RBW = 1 % to 5 % of the OBW
4. Set VBW $\geq 3 \times$ RBW
5. Video averaging is not permitted. Where practical, a sample detection and single sweep mode shall be used. Otherwise, peak detection and max hold mode (until the trace stabilizes) shall be used.
6. Use the 99 % power bandwidth function of the instrument (if available).
7. If the instrument does not have a 99 % power bandwidth function, the trace data points are recovered and directly summed in power units. The recovered amplitude data points, beginning at the lowest frequency, are placed in a running sum until 0.5 % of the total is reached; that frequency is recorded as the lower frequency. The process is repeated until 99.5 % of the total



is reached; that frequency is recorded as the upper frequency. The 99% occupied bandwidth is the difference between these two frequencies.

6.3. Test result

	Frequency (MHz)	26dB Bandwidth (MHz)	99% Bandwidth (MHz)
802.11a	5180	29.037	17.359
	5200	27.621	17.385
	5240	27.556	17.363
802.11n (HT20)	5180	21.593	17.901
	5200	21.419	17.914
	5240	21.472	17.886
802.11n (HT40)	5190	39.311	36.139
	5230	39.231	36.150



6dB bandwidth

	Frequency (MHz)	6dB Bandwidth (MHz)	Limit (MHz)
802.11a	5745	16.336	>0.5
	5785	16.334	>0.5
	5825	16.374	>0.5
802.11n (HT20)	5745	17.613	>0.5
	5785	17.280	>0.5
	5825	17.670	>0.5
802.11n (HT40)	5755	36.389	>0.5
	5795	36.410	>0.5

	Frequency (MHz)	99% Bandwidth (MHz)
802.11a	5745	17.081
	5785	17.035
	5825	17.123
802.11n (HT20)	5745	17.885
	5785	17.905
	5825	17.852
802.11n (HT40)	5755	36.140
	5795	36.130



Band 1

802.11a 5180MHz

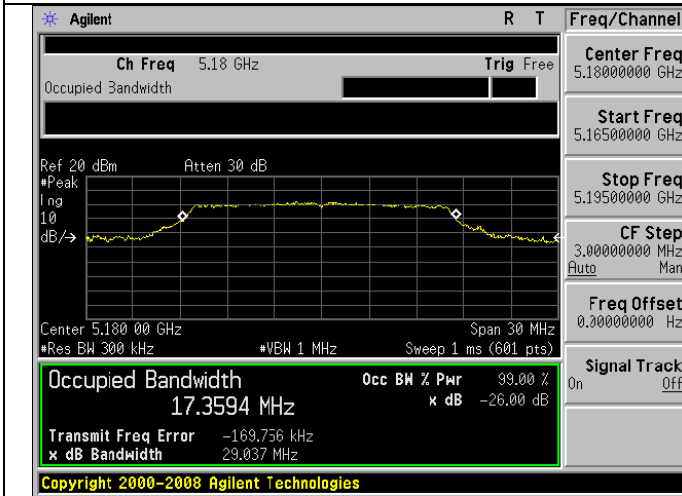

802.11n20MHz 5180MHz

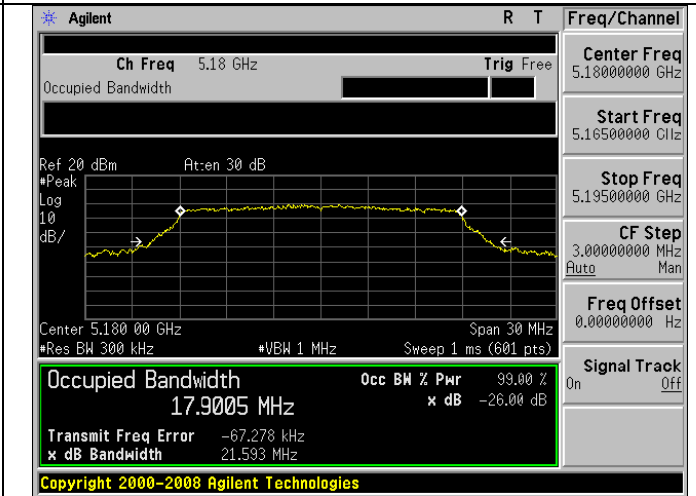

802.11a 5220MHz

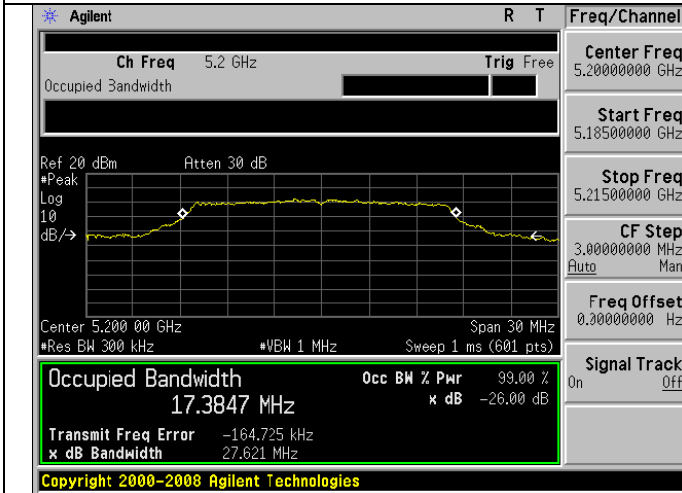

802.11n20MHz 5200MHz

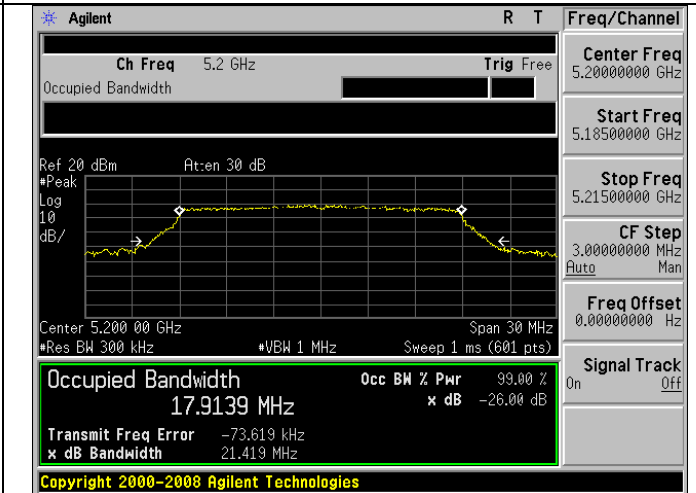

802.11a 5240MHz

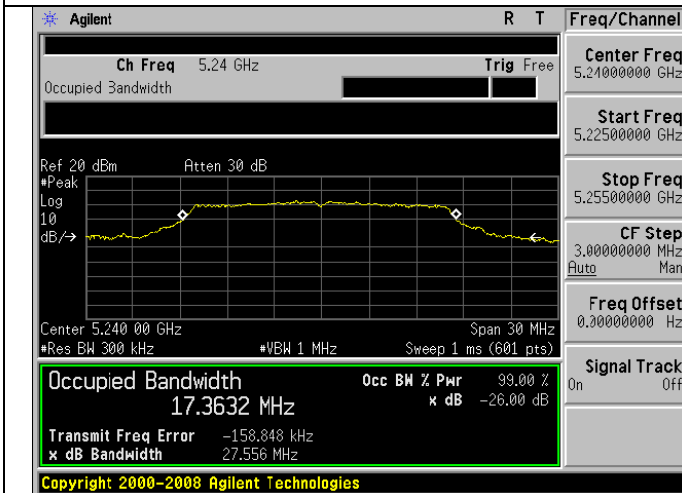

802.11n20MHz 5240MHz

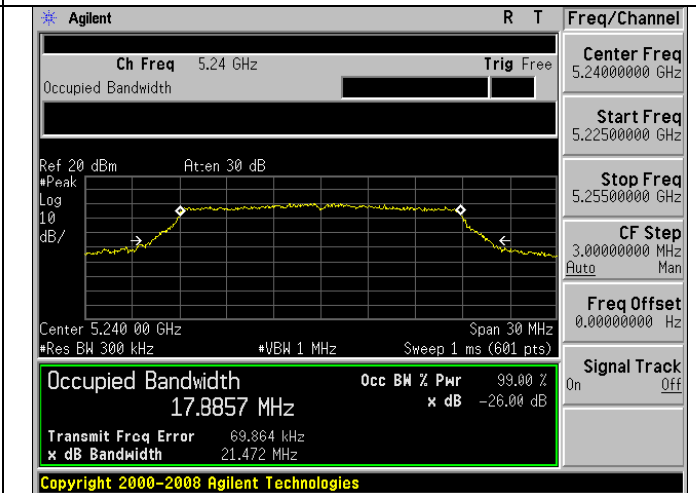



Band 1

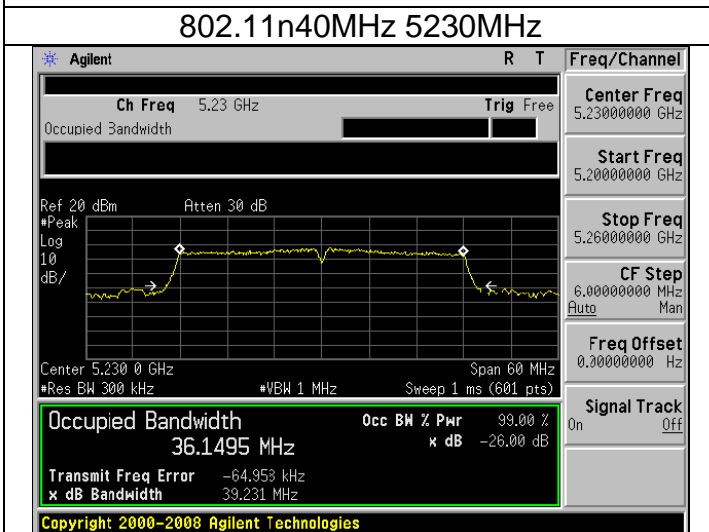
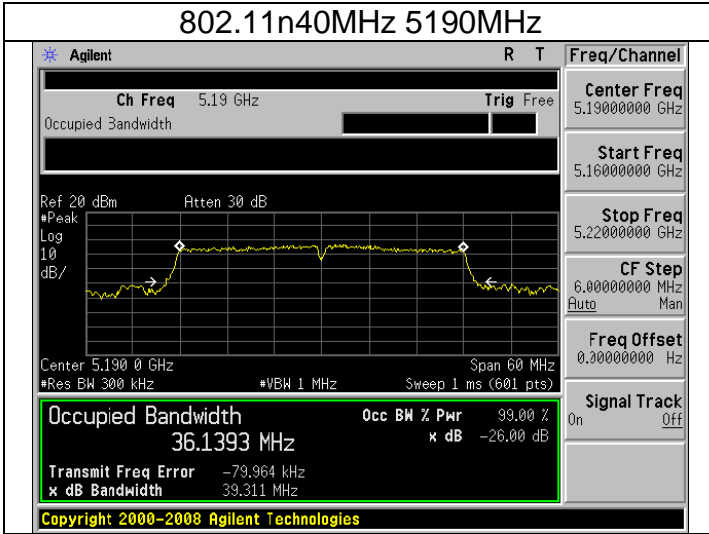



Band 4

802.11a 5745MHz

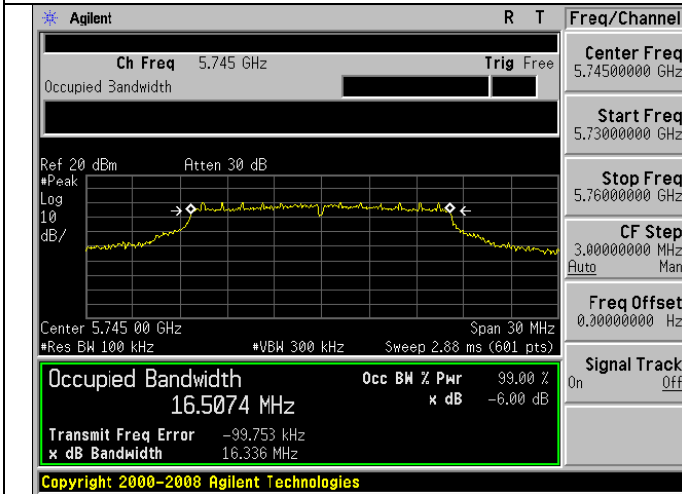

802.11n20MHz 5745MHz

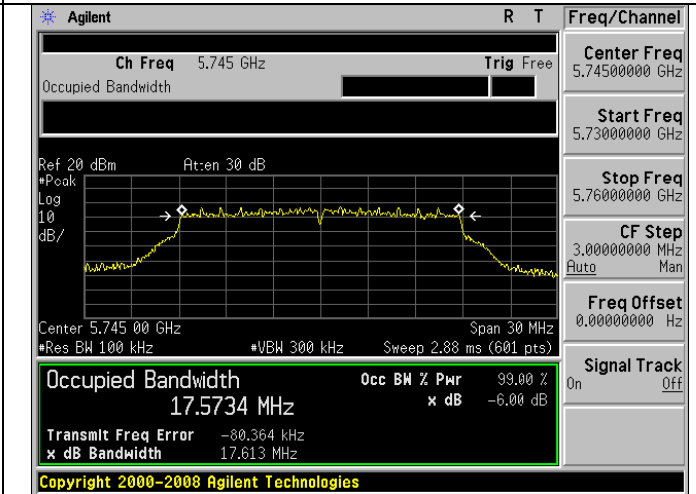

802.11a 5785MHz

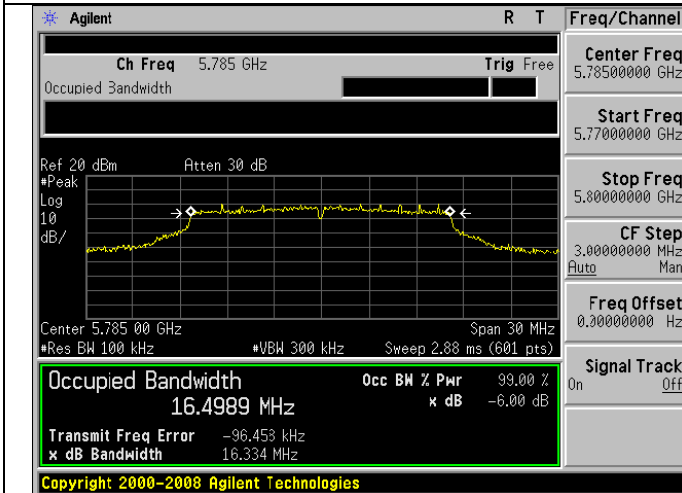

802.11n20MHz 5785MHz

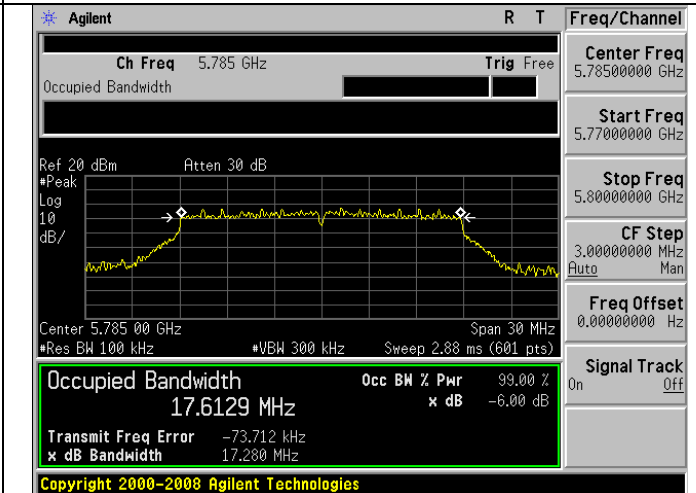

802.11a 5825MHz

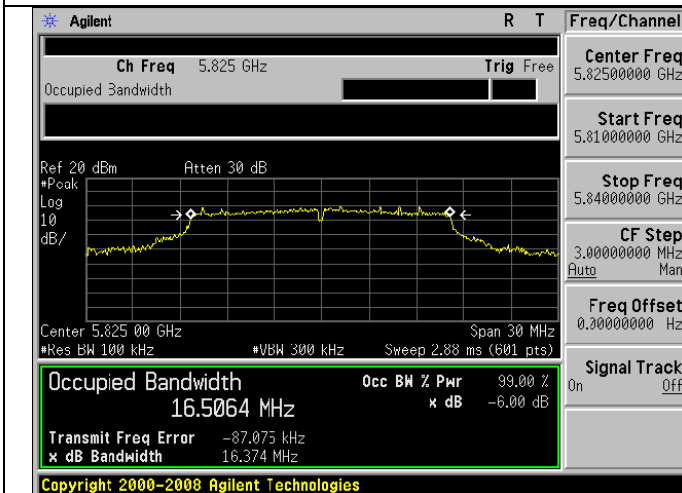

802.11n20MHz 5825MHz

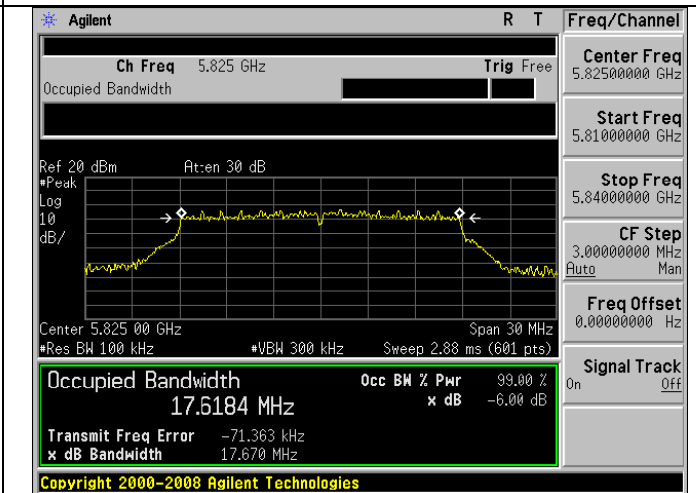



Band 4

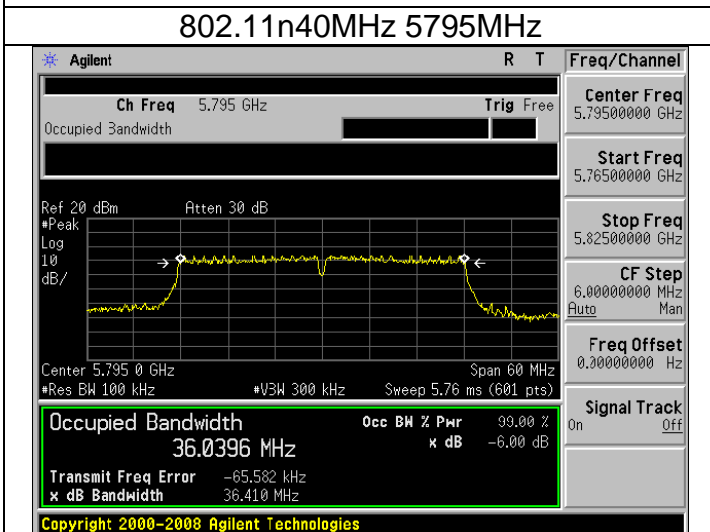
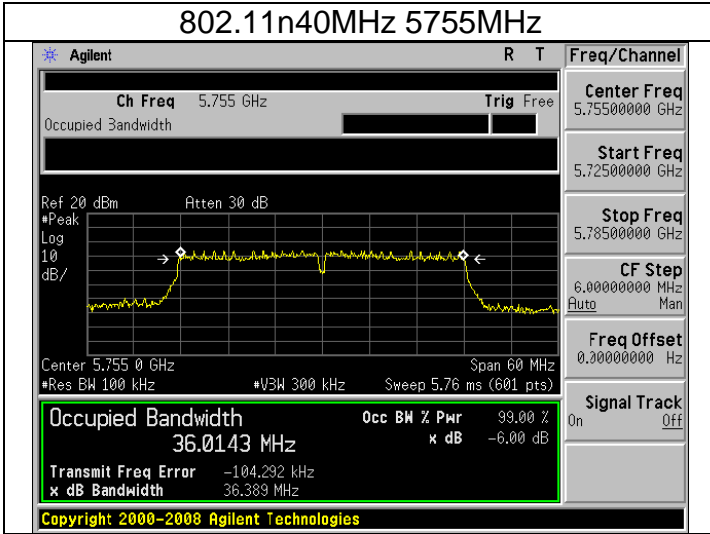



99% bandwidth
Band 4

802.11a 5745MHz

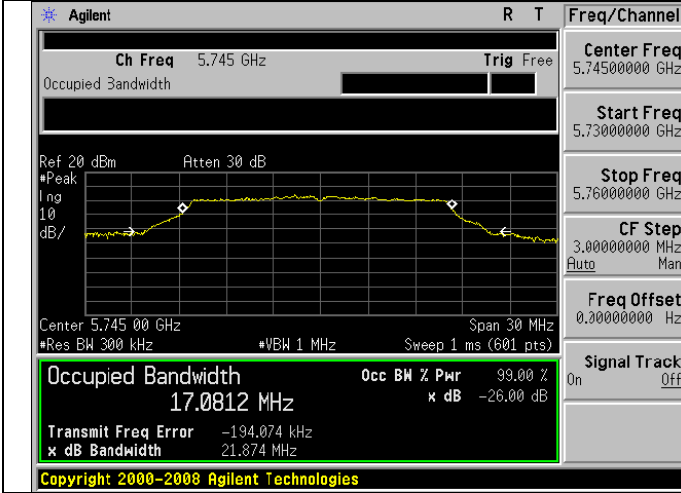

802.11n20MHz 5745MHz

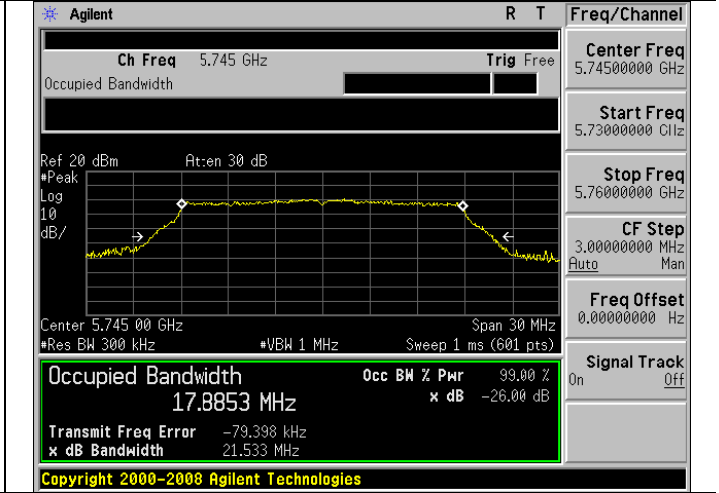

802.11a 5785MHz

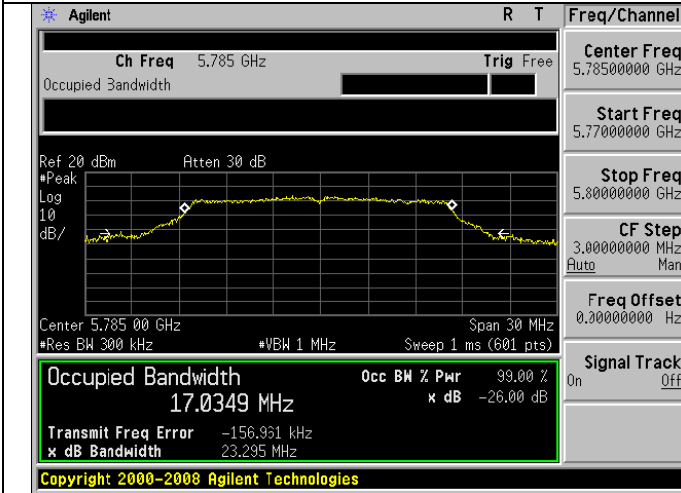

802.11n20MHz 5785MHz

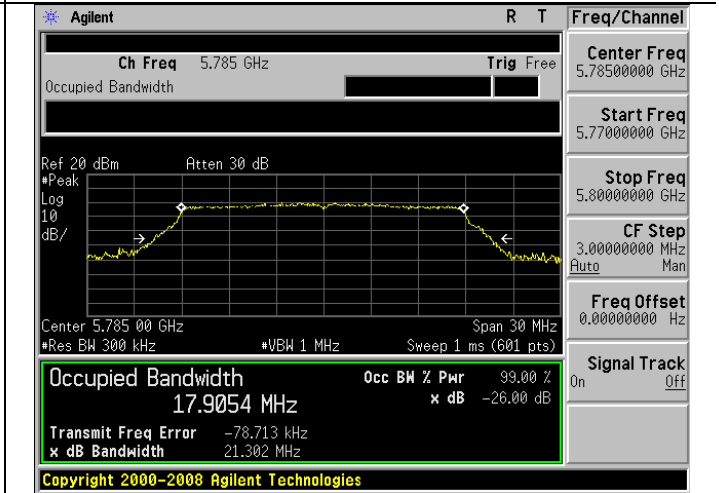

802.11a 5825MHz

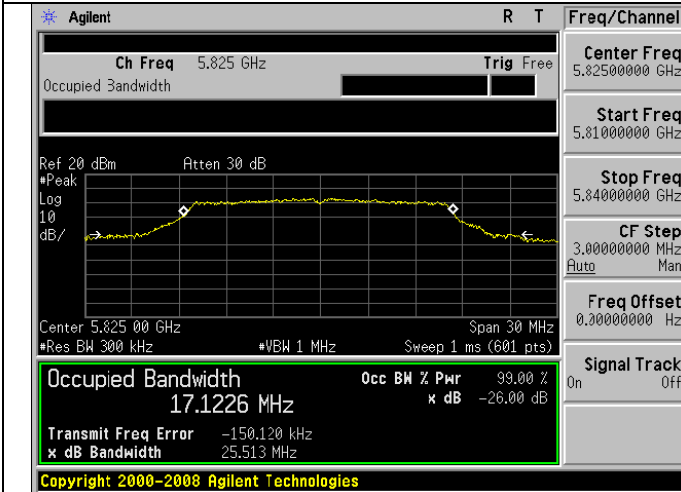

802.11n20MHz 5825MHz

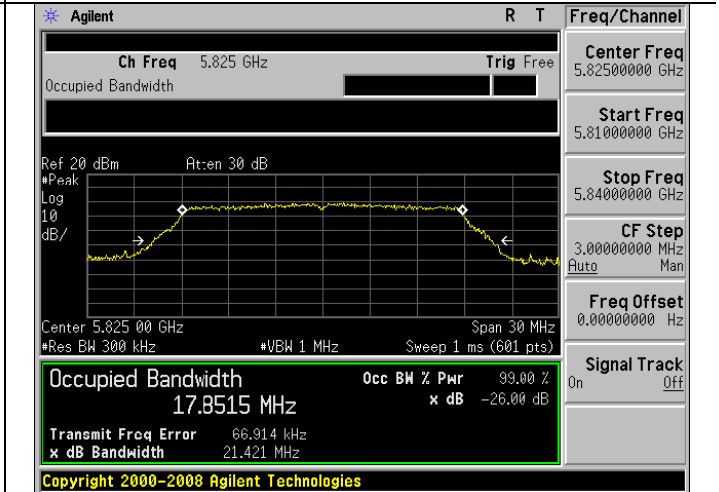



Band 4

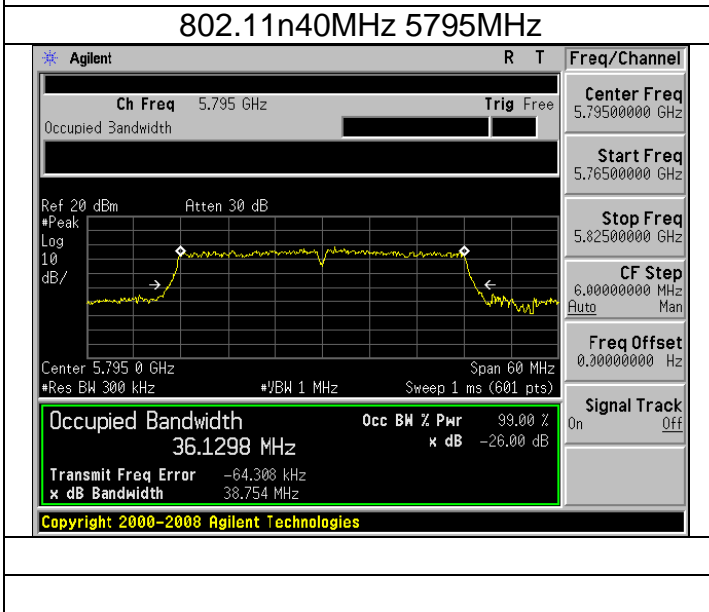
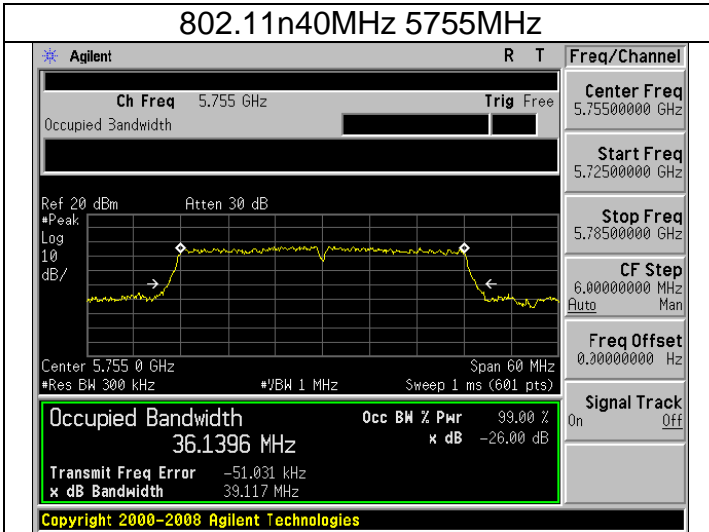



7. OUTPUT POWER TEST

7.1. Limits

For FCC limit:

For the band 5.15-5.25 GHz, the maximum conducted output power over the frequency band of operation shall not exceed 1 W provided the maximum antenna gain does not exceed 6 dBi.

For the band 5.725-5.85 GHz, the maximum conducted output power over the frequency band of operation shall not exceed 1 W.

For IC limit:

For the band 5.15-5.25 GHz, the maximum e.i.r.p. shall not exceed 30 mW or $1.76 + 10 \log_{10} B$, dBm, whichever is less.

For the band 5.725-5.85 GHz, The maximum conducted output power shall not exceed 1 W

7.2. Test setup

1. The maximum average conducted output power can be measured using Method PM-G (Measurement using a gated RF average power meter):
2. Measurements may be performed using a wideband gated RF power meter provided that the gate parameters are adjusted such that the power is measured only when the EUT is transmitting at its maximum power control level. Since the measurement is made only during the ON time of the transmitter, no duty cycle correction factor is required.
 - a. The Transmitter output (antenna port) was connected to the power meter.
 - b. Turn on the EUT and power meter and then record the power value.
 - c. Repeat above procedures on all channels needed to be tested.



7.3. Test result

Band1

	Frequency (MHz)	Output Power(dBm)	FCC Limit (dBm)	Result
802.11a	5180	17.38	23.98	Pass
	5220	17.34	23.98	Pass
	5240	17.31	23.98	Pass
802.11n (HT20)	5180	15.28	23.98	Pass
	5220	15.30	23.98	Pass
	5240	15.19	23.98	Pass
802.11n (HT40)	5190	14.30	23.98	Pass
	5230	14.23	23.98	Pass

Band4

	Frequency (MHz)	Output Power(dBm)	Duty factor (dB)	Total Output Power(dBm)	FCC Limit (dBm)	Result
802.11a	5745	17.40	0	17.40	30.00	Pass
	5785	17.41	0	17.41	30.00	Pass
	5825	17.34	0	17.34	30.00	Pass
802.11n (HT20)	5745	15.24	0	15.24	30.00	Pass
	5785	15.21	0	15.21	30.00	Pass
	5825	15.25	0	15.25	30.00	Pass
802.11n (HT40)	5755	14.25	0	14.25	30.00	Pass
	5795	14.19	0	14.19	30.00	Pass



8. PEAK POWER SPECTRAL DENSITY TEST

8.1. Limits

For FCC limit:

For the band 5.15-5.25 GHz, the maximum power spectral density shall not exceed 17 dBm in any 1 megahertz band

For the band 5.725-5.85 GHz, the maximum power spectral density shall not exceed 30 dBm in any 500 kHz band.

For IC limit:

For the band 5.15-5.25 GHz, The power spectral density shall not exceed 11 dBm in any 1.0 MHz band

For the band 5.725-5.85 GHz, The output power spectral density shall not exceed 30 dBm in any 500 kHz band

8.2. Test setup

1. Place the EUT on the table and set it in transmitting mode.
2. The testing follows FCC KDB 789033 D02.
3. Remove the antenna from the EUT and then connect a low loss RF cable from the antenna port to Spectrum.
4. For U-NII1, U-NII-2A, U-NII-2C Band:
Set RBW=1MHz, VBW=3MHz, where span is enough to capture the entire bandwidth, Sweep time = Auto (601 pts), detector = sample, traces 100 sweeps of video averaging. (SA-2 with the omission of procedure x, the integration with 26dB EBW bandwidth)
For U-NII-3 Band:
Set RBW=510 kHz, VBW=3*RBW, where span is enough to capture the entire bandwidth, Sweep time = Auto (601 pts), detector = sample, traces 100 sweeps of video averaging. (SA-2 with the omission of procedure x, the integration with 26dB EBW bandwidth)
5. Use the cursor on spectrum to peak search the highest level of trace
6. Record the max. reading and add $10 \log(1/\text{duty cycle})$.



8.3. Test data

Test data as below

Band 1

	Frequency (MHz)	Reading Level (dBm)	Duty factor (dB)	PPSD (dBm)	FCC Limit (dBm)	Result
802.11a	5180	4.86	0	4.86	11.00	Pass
	5220	4.75	0	4.75	11.00	Pass
	5240	5.22	0	5.22	11.00	Pass
802.11n (HT20)	5180	1.39	0	1.39	11.00	Pass
	5220	1.39	0	1.39	11.00	Pass
	5240	2.56	0	2.56	11.00	Pass
802.11n (HT40)	5190	-0.44	0	-0.44	11.00	Pass
	5230	-0.15	0	-0.15	11.00	Pass

Band 4

	Frequency (MHz)	Reading Level (dBm)	Duty factor (dB)	PPSD (dBm)	FCC Limit (dBm)	Result
802.11a	5745	5.62	0	5.62	30.00	Pass
	5785	5.55	0	5.55	30.00	Pass
	5825	4.82	0	4.82	30.00	Pass
802.11n (HT20)	5745	1.85	0	1.85	30.00	Pass
	5785	2.10	0	2.10	30.00	Pass
	5825	2.36	0	2.36	30.00	Pass
802.11n (HT40)	5755	-0.99	0	-0.99	30.00	Pass
	5795	-1.29	0	-1.29	30.00	Pass



Band 1

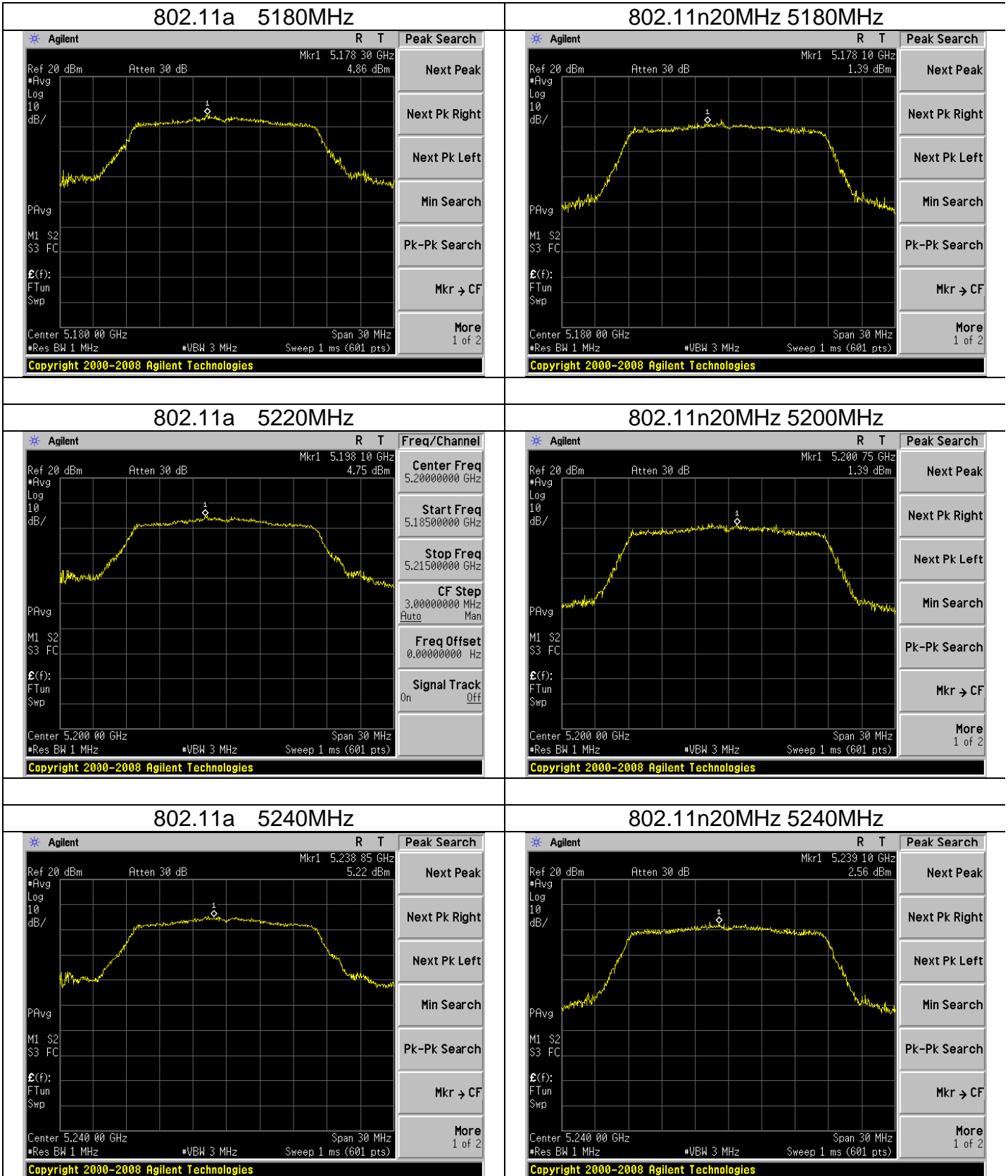



Band 1

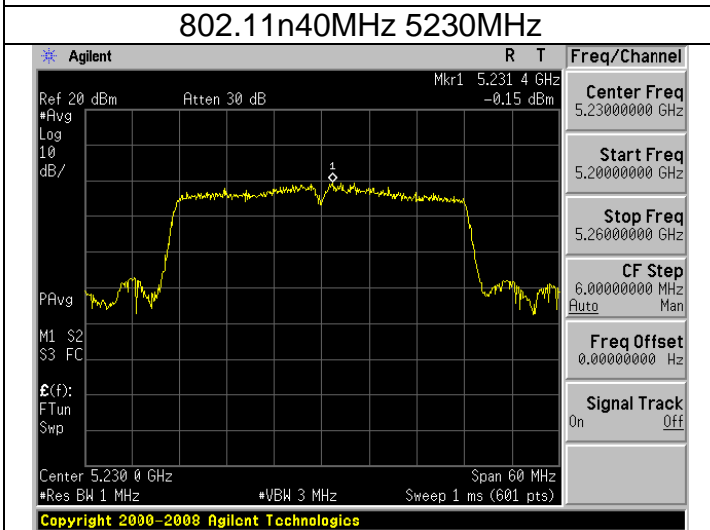
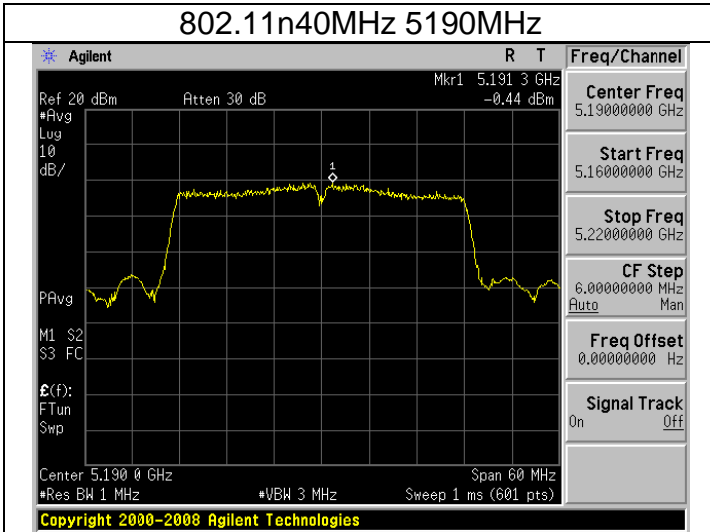



Band 4

802.11a 5745MHz

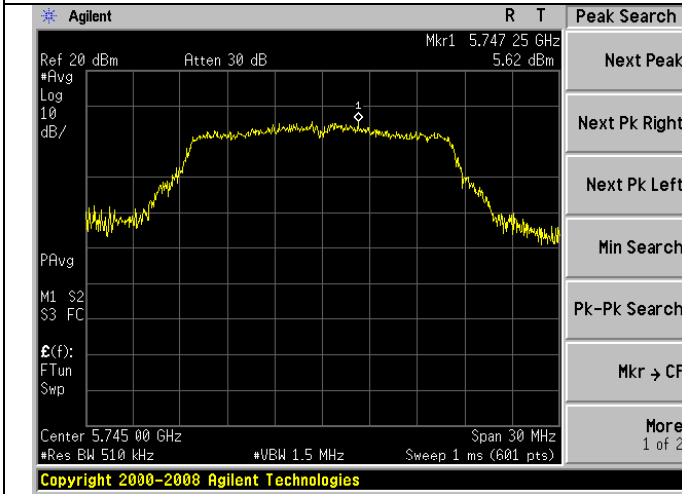

802.11n20MHz 5745MHz

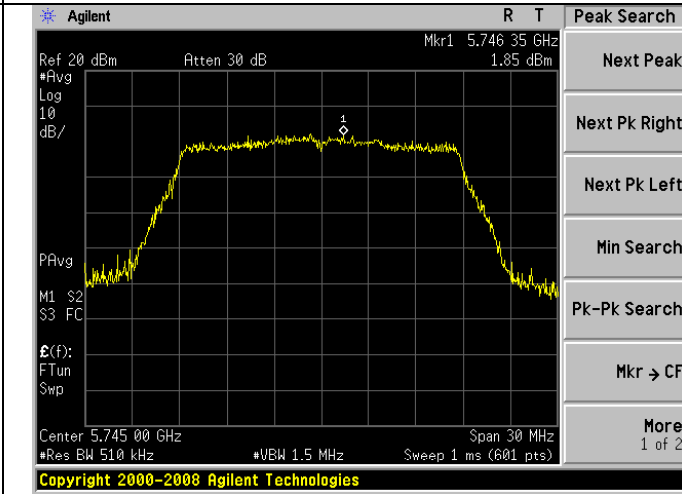

802.11a 5785MHz

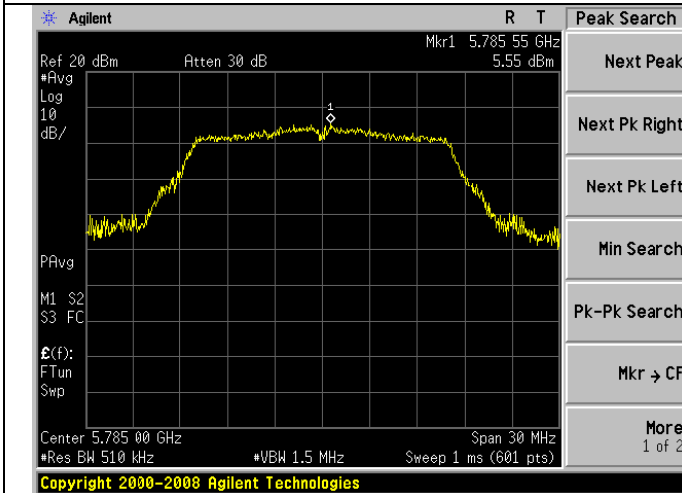

802.11n20MHz 5785MHz

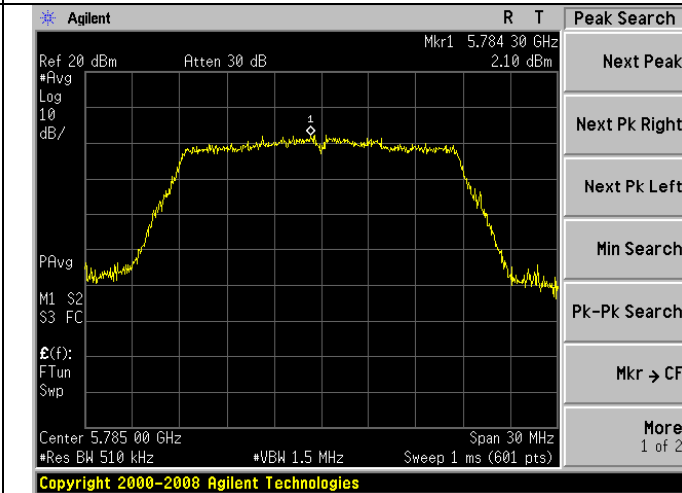

802.11a 5825MHz

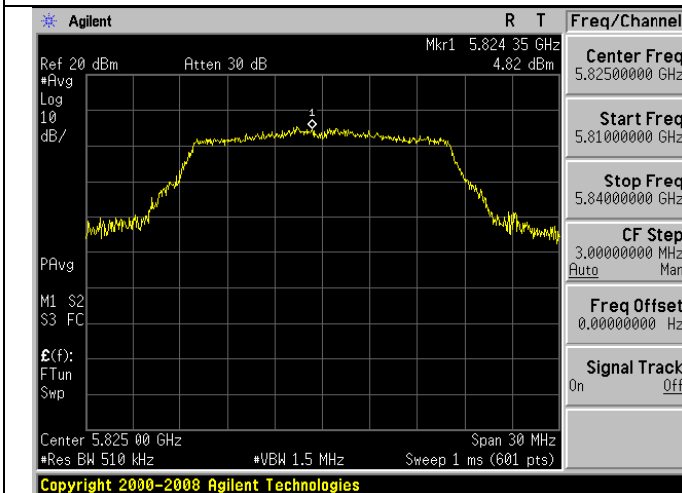

802.11n20MHz 5825MHz

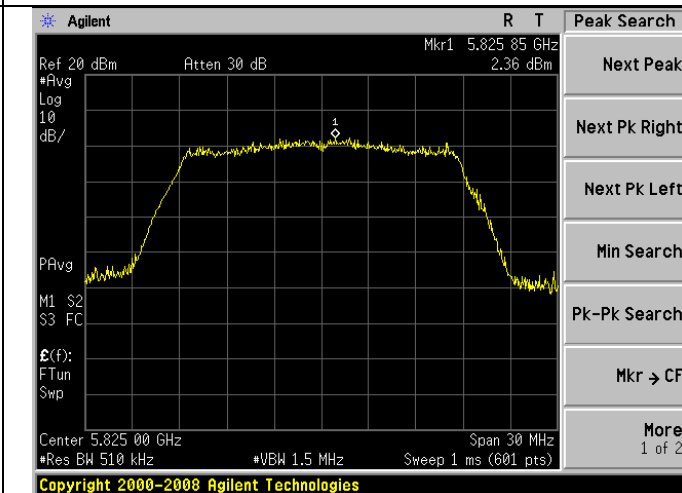



Band 4

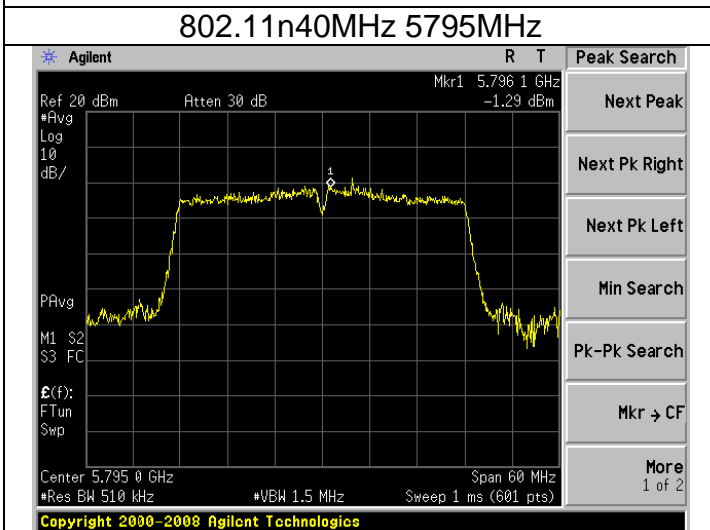
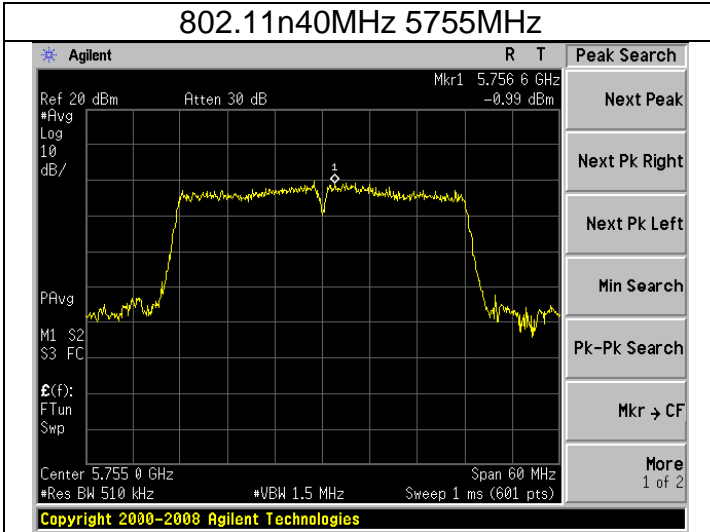



9. DUTY CYCLE TEST SIGNAL

Pre-analysis Check: While conducting average power measurement, duty cycle of each mode shall be checked to ensure its duty cycle in order to compensate for the loss due to insufficient ratio of duty cycle.

All duty cycle is pre-scanned, and result as obtained below shows only the most representative ones where duty cycle is conducted as the given transmission with given virtual operation that expresses the percentage.

Formula:

$$\text{Duty Cycle} = \text{Ton} / (\text{Ton} + \text{Toff})$$

Measurement Procedure:

1. Set span = Zero
2. RBW = 8MHz
3. VBW = 8MHz,
4. Detector = Peak

Duty Cycle:

Operation Mode	Duty Cycle	Duty Fator (dB) $10 * \log (1/ \text{Duty cycle})$
802.11a	100%	0
802.11n(HT20)	100%	0
802.11n(HT40)	100%	0



10. TRANSMISSION IN THE ABSENCE OF DATA

10.1. Limits

According to §15.407(c)

The device shall automatically discontinue transmission in case of either absence of information to transmit or operational failure. These provisions are not intended to preclude the transmission of control or signaling information or the use of repetitive codes used by certain digital technologies to complete frame or burst intervals. Applicants shall include in their application for equipment authorization a description of how this requirement is met.

10.2. Test result

No non-compliance noted:

Refer to the theory of operation.

11. PHOTOGRAPHS OF TEST SET-UP

Radiated Emission Test

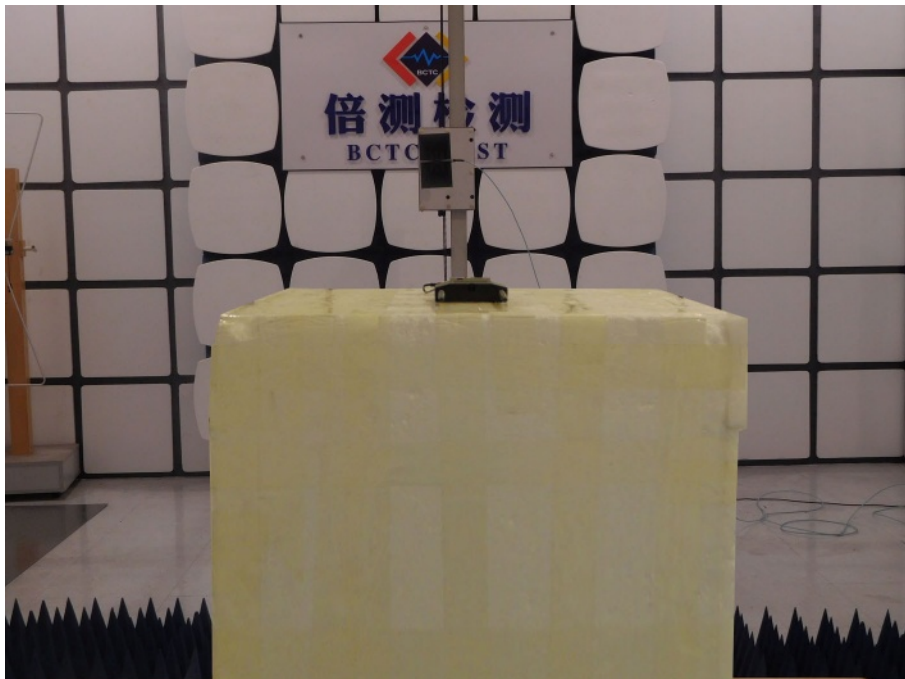
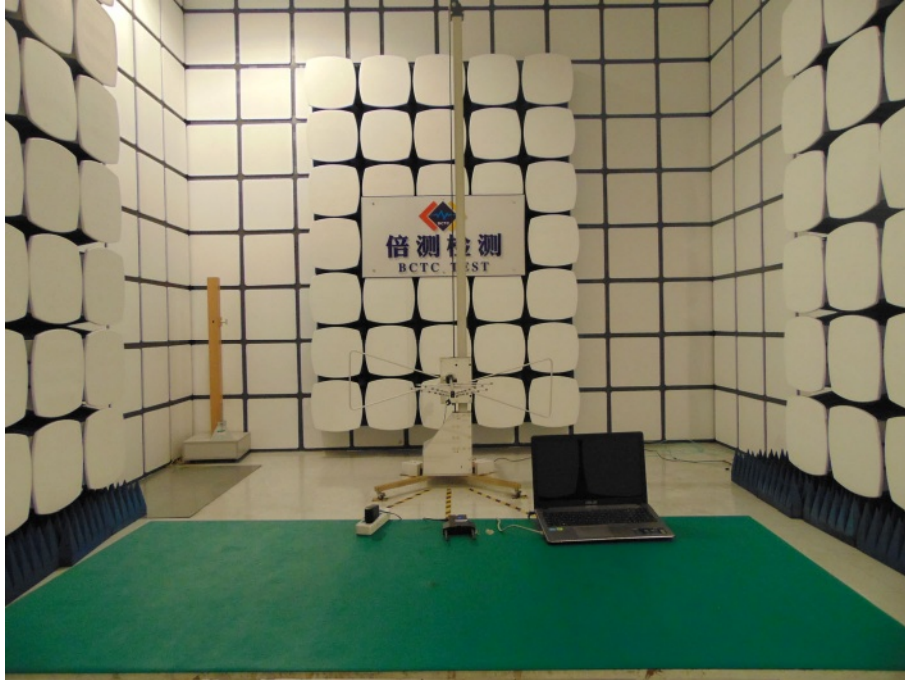

Conducted Measurement Photos



12. PHOTOGRAPHS OF THE EUT

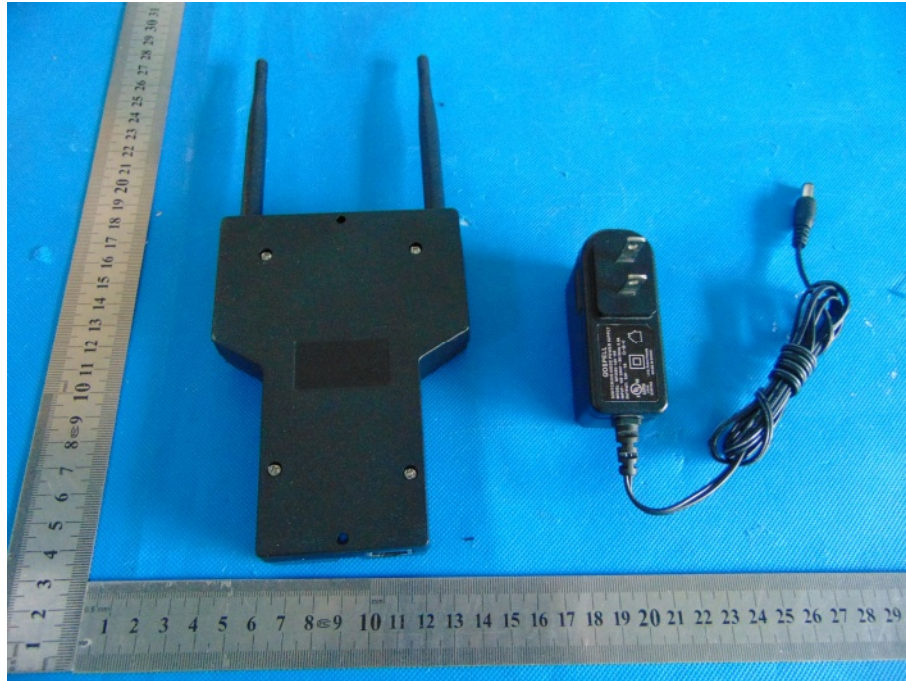

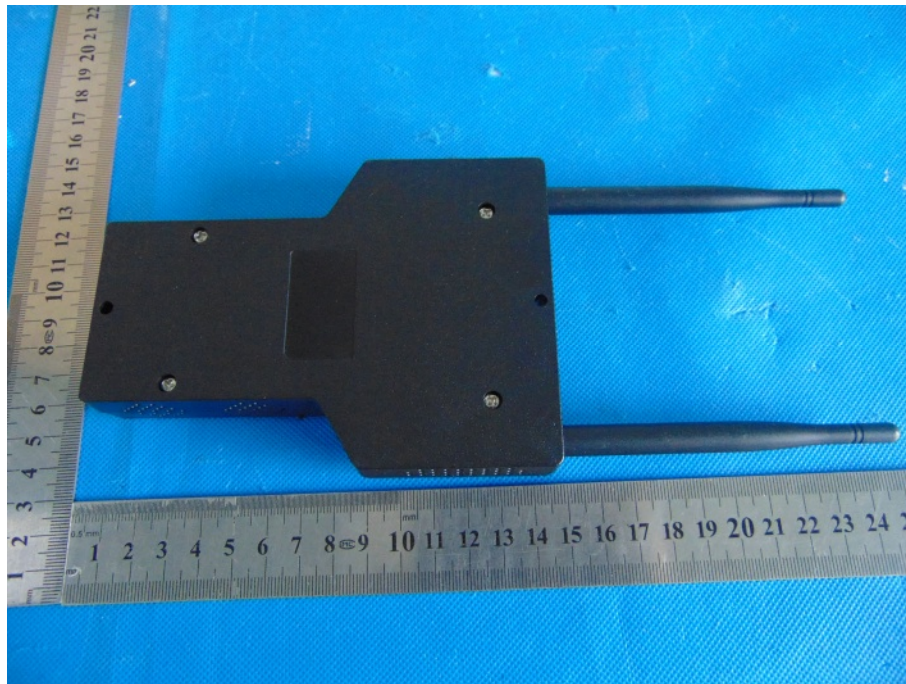
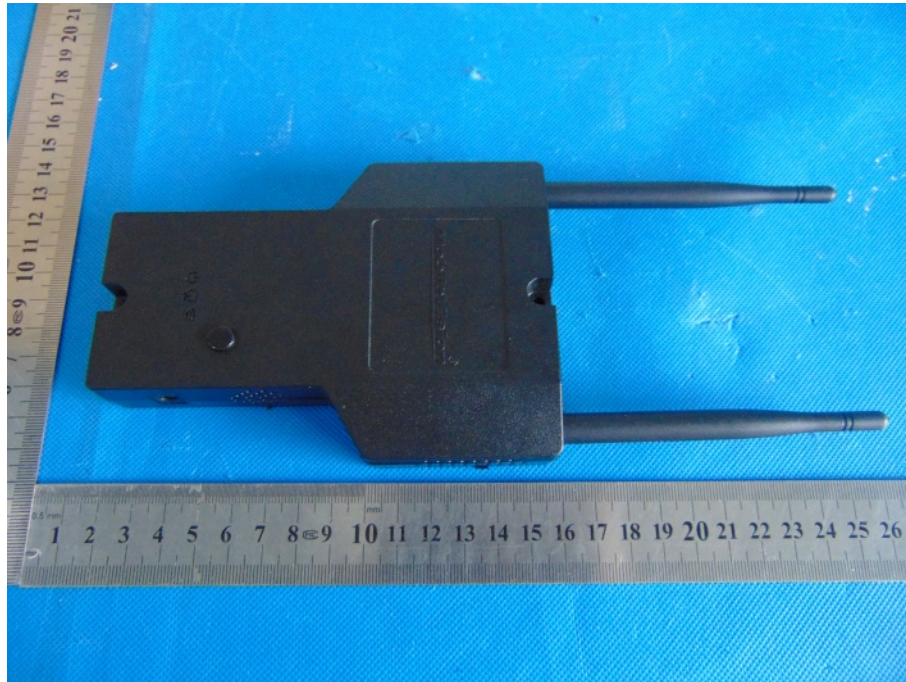

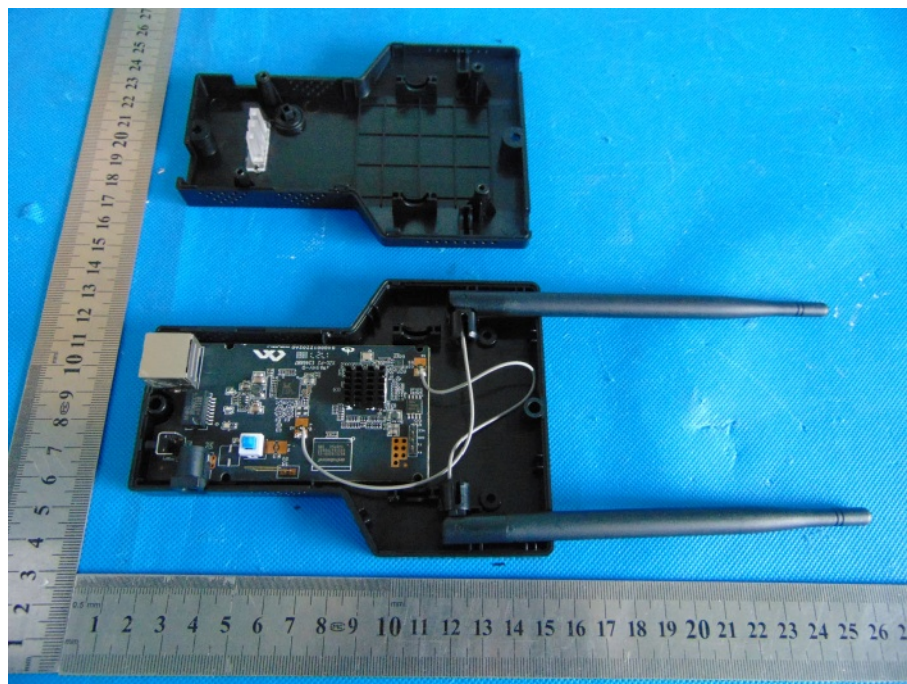
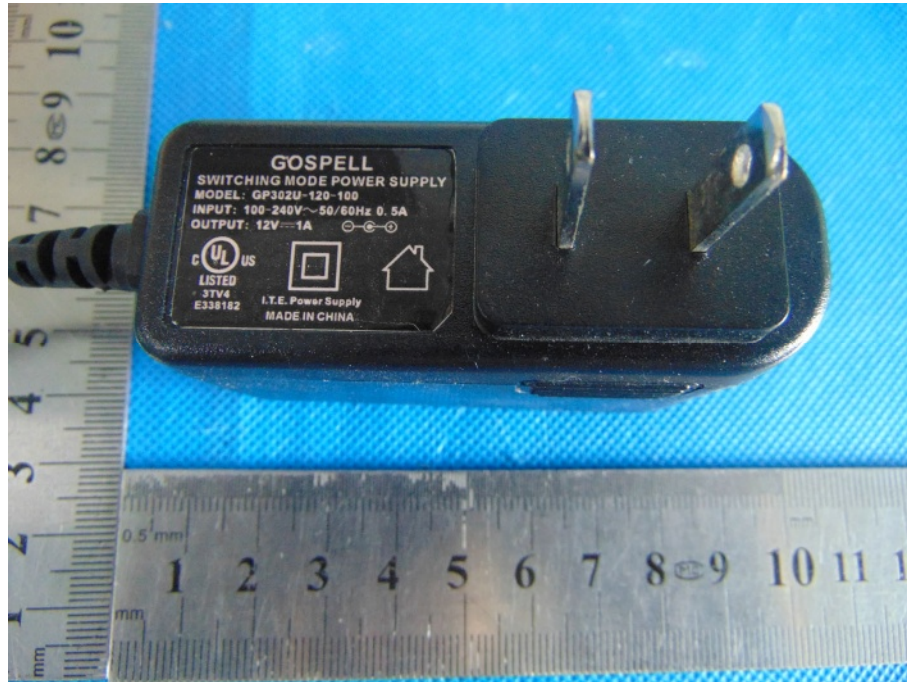

***** END OF REPORT *****