

**XJ200**

**1. GENERAL WARNING**

**1.1 TO BE READ BEFORE USING THIS MANUAL.**

- This manual forms an integral part of the product and must be kept near the device for easy and quick consultation.
- The device must not be used for purposes different than those described below and particularly, it cannot be used as a safety device.
- Verify the limits of application before proceeding.

**1.2 SAFETY PRECAUTIONS**

- Verify that the connections comply with the instructions in this manual before connecting the device.
- Do not expose the unit to water or humidity: use the device only within the stipulated working limits, avoiding sudden changes in temperature and high atmospheric humidity in order to prevent condensation from forming.
- Caution: disconnect the electrical connections of the device before any maintenance.
- The module must never be opened.
- If the device is faulty or malfunctions, return it to the retailer or to "DIXELL s.r.l." (refer to address) with a precise description of the fault.

**2. GENERAL DESCRIPTION**

The wireless communication modules of the XJ200 range are a radio communication system for Dixell monitoring systems.

The iCOOLL range consists of the XJ200 radio module and its power supplier PW-200J. XJ200 can cover a variety of functions within the monitoring network:

- Master:** when it is connected to the X-WEB monitoring system.
- Slave/Repeater:** when it is connected to the subnets of devices equipped with RS485.
- Repeater:** when it is assigned the function as a simple bridge towards other subnets that cannot be reached directly by the master.

The XJ200 modules enable 2-way communication between Dixell devices/modules equipped with an RS485 output that are appropriately connected to each other and the monitoring unit of the X-WEB ranges, thereby replacing the connection via an RS485 cable.

Up to 200 devices can be connected to the same XJ200 (communication between the module and the devices is via RS485), thereby covering several workstations with the same communication module.

The maximum distance possible between the XJ200 modules in an open space (with no obstacles) is 200 metres. This distance can be remarkably reduced in the presence of interference such as radio emitters, generators of electrical or magnetic fields that can affect the proper communication between the XJ200 modules.

The range of serial addresses allowed on the instruments connected to the iCOOLL modules is from 1 to 244.

N.B. In order to work with the iCOOLL modules, the instruments must be equipped with an RS485 serial port and use ModBUS-RTU communication protocol.

**3. FRONT PANEL**

LED: the module has a few LED signals



- POWER** Green - Flashing with a frequency of 1 Hz: the module is ON and running
- RS485** Yellow - Data is being transmitted/received via RS485 by the module
- RADIO** Green -The module is transmitting via radio

**4. INSTALLATION AND ASSEMBLY**

**4.1 PACKAGE CONTENTS**

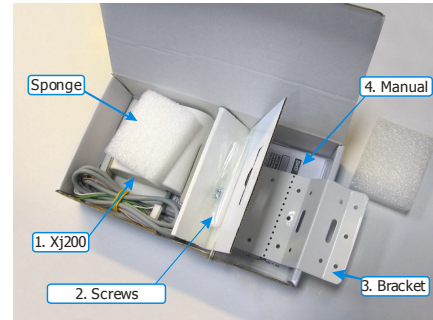

Each XJ200 package contains the following components:

1. XJ200 radio device
2. 2 self-tapping screws 3.9x6.5T to fix the XJ200 to the fixing bracket
3. Wall fixing bracket
4. Instructions manual

**4.2 TOOLS TO FIX THE XJ200**

**4.2.1 DIRECT FIXING TO THE WALL**

Parts required for assembly (not supplied)

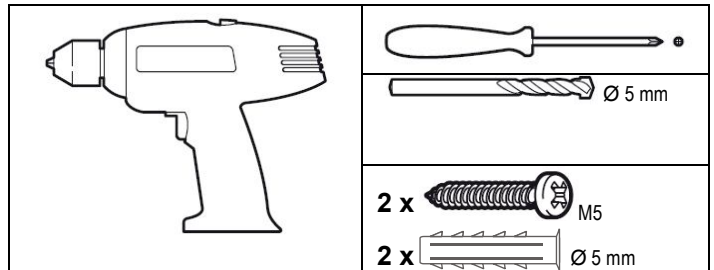

1. To fix the module directly to the wall, use the cut out below to make the 2 holes "B" at the distance indicated in fig. 1.

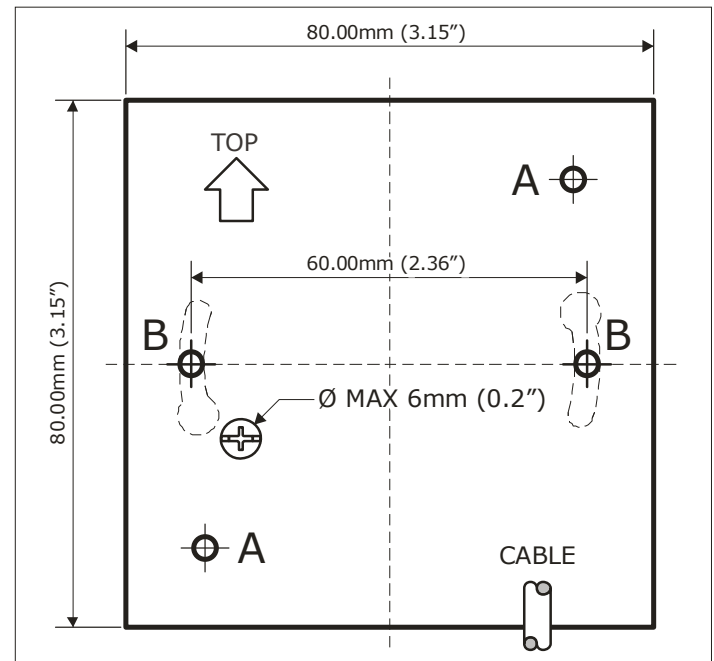
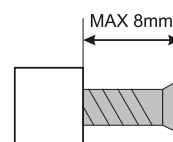

Fig. 1

Insert the dowels and fix the screws with a maximum distance of 8 mm from the head to the wall

- 2.



3. Fix the XJ200 to the head of the screws by rotating the container appropriately

**4.2.2 FIXING WITH THE USE OF A BRACKET**

A suitable fastening bracket is included in every package to be used to:

- a. shelves mount fitting;
- b. pipemount fitting with appropriate retaining clamps (not supplied)
- c. wall mount fitting

as shown in the following pictures:

**!!!!ATTENTION!!!!**  
Set the XJ200 in the desired place in a **VERTICAL POSITION**.

Avoid horizontal or slanting positions.

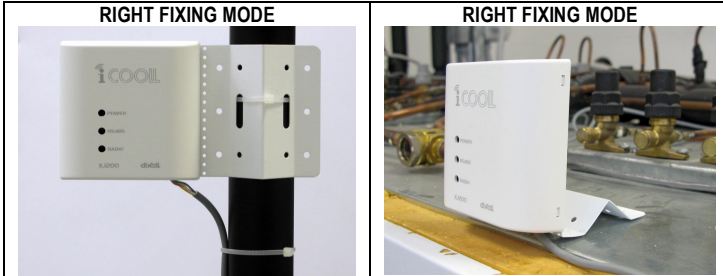

**Parts required for assembly (not supplied)**



1. Fix the XJ200 to the fixing bracket using the 2 screws in the package
2. The 2 screws are to be entered in holes "A" as shown in Fig. 1.
3. The bracket can be bent and fixed so that the XJ200 is installed in a vertical position.

**4.3 RECOMMENDATIONS FOR PROPER INSTALLATION**

- If possible, place the module high up in order to guarantee enhanced data transmission/reception.
- If possible, avoid intermediate obstacles such as barriers, walls, floors and counters between the modules.
- If necessary, pass through the obstacle using the cable and install the module on the opposite side in order to have it in direct view with the master module connected to the X-WEB.
- The maximum distance possible between the XJ200 modules in an open space (with no obstacles) is 200 metres.
- If the installation spans over a number of floors, try to position all the modules on the same floor and connect the devices via cable in order to prevent communication problems due to obstacles caused by the floor/ceiling.
- The allowed temperature range for correct functioning is between 0 and 60 °C. Avoid places subject to heavy vibrations, corrosive gas, excessive filth or humidity.

**5. CONNECTIONS**

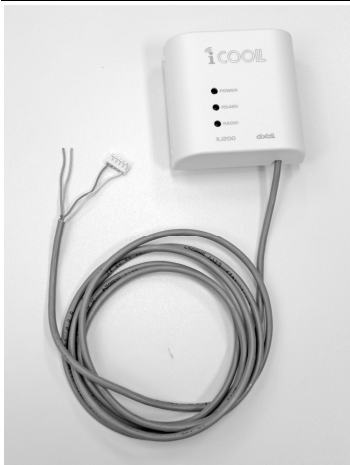

Each module is supplied complete with a 1.5-metre cable to connect the serial communication line and the power line. The XJ200 is powered by the PW-200J power supplier and therefore, it is connected to the RS485 serial line. The following types of connection are possible.

**6. X-WEB - XJ200 MASTER CONNECTION**

**6.1 TRANSFORM THE XJ200 TO MASTER**

The XJ200 connected to the X-WEB must be configured as Master.

To do so:

- a. Remove the cover of the XJ200.
- b. Close the jumper found inside the XJ200 by inserting the micro switch as shown in the picture below.

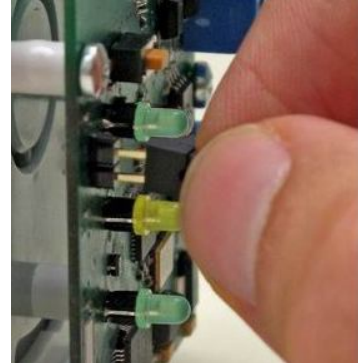

- c. Close the cover of the XJ200 once again.
- d. Connect the XJ200, PW200J and the X-WEB as shown in the connection diagram below.

**6.2 XJ200 -X-WEB CONNECTION**

**XJ200 and PW-200J connection**

- a. Disconnect the power supply from the PW200J
- b. Connect the GREEN wire to the RS485 "+" terminal of the PW-200J
- c. Connect the PINK wire to the RS485 "-" terminal of the PW-200J
- d. Connect the white connector to the "+5V supply" connector of the PW-200J

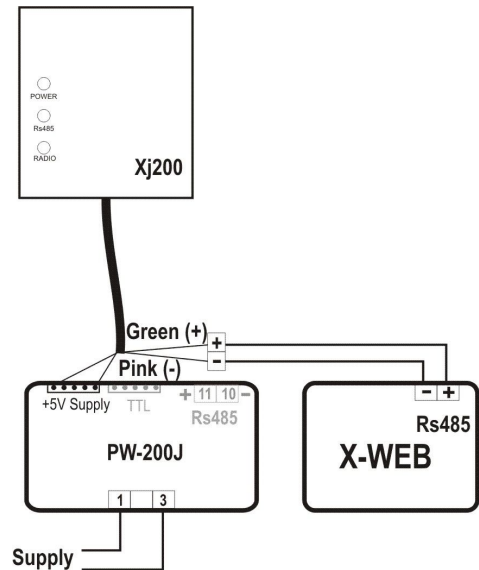

**XJ200 and X-WEB connection**

Use the disconnecting terminal supplied with the PW-200J as a bridge of the RS485 line.

The connection between the XJ200 and X-WEB is then implemented as follows:  
Connect the GREEN wire of the XJ200 to the RS485 "+" terminal of the X-WEB  
Connect the PINK wire of the XJ200 to the RS485 "-" terminal of the X-WEB

Power the X-WEB and the PW200J once again.

**7. XJ200 CONNECTION AND DEVICES EQUIPPED WITH A SERIAL OUTPUT**

**7.1 DEVICE EQUIPPED WITH AN RS485 SERIAL OUTPUT**

**7.1.1 Device with an RS485 output but not able to power the XJ200.**

E.G. Ranges: XR100C; XR500C; XR75CX and XR77CX.  
**XJ200 and PW-200J connection**

Connect the white connector to the "+5V supply" connector of the PW-200J.  
 Connect the other devices to the RS485 serial line in compliance with the polarity.  
 Use the disconnecting terminal supplied with the PW-200J as a bridge of the RS485 line with the XJ200 as follows:  
 Connect the GREEN wire of the XJ200 to the RS485 "+" terminal.  
 Connect the PINK wire of the XJ200 to the RS485 "-" terminal.

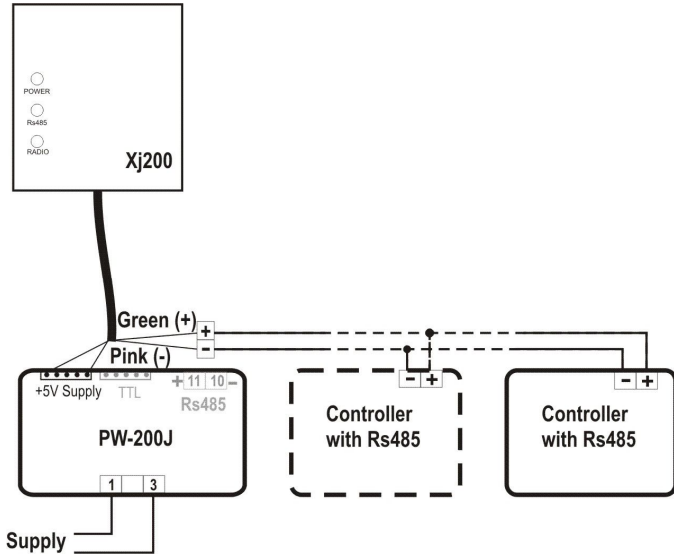

**7.2 DEVICE EQUIPPED WITH A TTL SERIAL OUTPUT**

**7.2.1 Device with a TTL output but not able to power the XJ200.**  
 E.G. Ranges: Prime CX, Wing Basic New, XC400C and XC600C

**XJ200 and PW-200J connection**  
 Connect the GREEN wire to the RS485 "+" terminal of the PW-200J.  
 Connect the PINK wire to the RS485 "-" terminal of the PW-200J.  
 Connect the white connector to the "+5V supply" connector of the PW-200J.  
**Controller connection with TTL and PW-200J**  
 Connect the other devices to the RS485 serial line in compliance with the polarity.  
 Connect the 2 TTL outputs of the PW200J and the device.  
 Then connect the RS485 line to the PW200J, in compliance with the polarity.

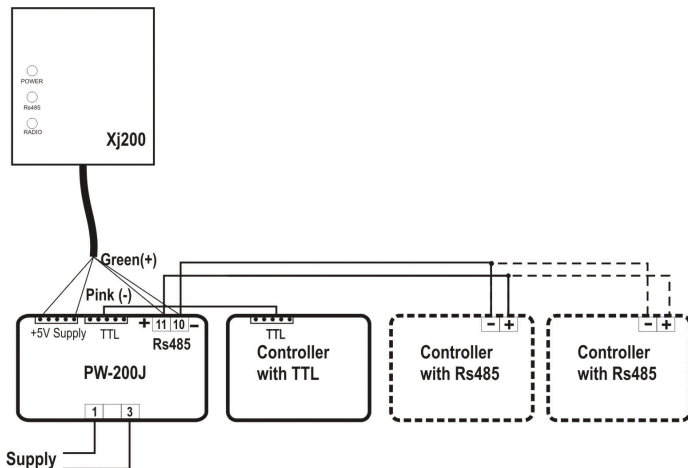

**8. CHECK OF GOOD CONNECTION QUALITY BETWEEN THE XJ200 MASTER AND THE OTHER XJ200 OF THE NETWORK**

The following must be implemented in order to verify good connection quality between an XJ200 and the master connected to the X-WEB:

1. Connect and power the XJ200 Master to the X-WEB
2. Set the XJ200 in place where it is to be installed
3. Power the XJ200 and press the LED Power button for a couple of seconds
4. A test cycle begins and lasts a few minutes
5. At the end of the cycle, the following remains on:
  - a. Good communication: the GREEN "RADIO" LED is on
  - b. Insufficient communication: the YELLOW "RS485" LED is on; in this case, try installing the XJ200 in a better position or connect another XJ200 between the Master and the XJ200 being tested.

**9. TECHNICAL DATA**

**Operating Frequency:**  
 Europe version: XJ200 -00000: 869.4 - 869.650 MHz  
 AUS and USA version: XJ200 -10000: 922 MHz  
**Container:** Self-extinguishing ABS  
**Format:** Front panel 80 x 80 mm; depth 5 mm  
**Power Supply:**  
 XJ200 +5Vdc (from the controller or from the PW-200J module)  
**Note:** the PW200J feeder or any Dixell controllers that can power the XJ200 are SELV-type. Max Power <18VA, DC current < 8A.  
**Power Consumption:** 0.30 VA max.  
**Operating Temperature:** from 0 to 60 °C  
**Storage Temperature:** -25 to 60  
**Relative Humidity:** 20 - 85% (no condensation)

**The XJ200 -0000 is compliant with the following standards:**  
 ETSI EN 300 220-2 V2.1.2 (2007-06)  
 ETSI EN 301 489-3 V1.4.1 (2002-08)  
 CEI EN 60950-1 (2007-02)  
 It therefore meets the essential requirements of the following Directives:

Radio and telecommunications terminal equipment 99/5/EC  
 Electromagnetic compatibility 2004/108/EC  
 Low Voltage equipment 2006/95/EC

**The XJ200 -1000 (922MHz) is compliant with the following standards:**

AS/NZS 4268: 2008:  
**Classification:** Schedule 1: Item 45  
 FCC 15.247

**The XJ200 -1000 (922MHz) is compliant to Part 15 of the FCC Rules:**  
 Operation is subject to the following two conditions:  
 (1) this device may not cause harmful interference, and  
 (2) this device must accept any interference received, including interference that may cause undesired operation."

Unauthorized repairs, changes or modifications could result in permanent damage to the equipment and void your warranty and your authority to operate this device under Part 15 of the FCC Rules.

NOTE: This equipment has been tested and found to comply with the limits for a Class A digital device, pursuant to part 15 of the FCC Rules. These limits are designed to provide reasonable protection against harmful interference when the equipment is operated in a commercial environment. This equipment generates, uses, and can radiate radio frequency energy and, if not installed and used in accordance with the instruction manual, may cause harmful interference to radio communications. Operation of this equipment in a residential area is likely to cause harmful interference in which case the user will be required to correct the interference at his own expense.

**The XJ200 -1000 (922MHz) is compliant to RSS 102**  
**Cet XJ200 -1000 (922MHz) instrument répond aux normes RSS 102**

The complete Declaration of Conformity can be found at:  
[www.dixell.com](http://www.dixell.com)





Dixell S.r.l. - 32010 Pieve d'Alpago (BL) ITALY - Z.I. Via dell'Industria, 27  
 Tel. +39.0437.9833 r.a. - Fax +39.0437.989313 - www.dixell.com - dixell@emerson.com