

FCC Test Report

Product Name : Multimedia System
Trade Name : Continental
Model No. : NAC EUR wave 3
FCC ID. : ZFW-NACEUR3

Applicant : Continental Automotive Rambouillet France SAS
Address : 1, rue de Clairefontaine, Rambouillet, 78120, France

Date of Receipt : Sep. 21, 2017
Issued Date : Oct. 20, 2017
Report No. : 1790307R-RFUSP01V00-A
Report Version : V1.0



The test results relate only to the samples tested.

The test report shall not be reproduced except in full without the written approval of DEKRA Testing and Certification Co., Ltd.

Test Report Certification

Issued Date : Oct. 20, 2017

Report No. : 1790307R-RFUSP01V00-A



Product Name : Multimedia System
Applicant : Continental Automotive Rambouillet France SAS
Address : 1, rue de Clairefontaine, Rambouillet, 78120, France
Manufacturer : Continental Automotive Czech Republic, s.r.o
Model No. : NAC EUR wave 3
FCC ID. : ZFW-NACEUR3
EUT Voltage : DC 12V
Testing Voltage : DC 12V
Trade Name : Continental
Applicable Standard : FCC CFR Title 47 Part 15 Subpart C Section 15.247: 2015
ANSI C63.10: 2013
Laboratory Name : Hsin Chu Laboratory
Address : No.372-2, Sec. 4, Zhongxing Rd., Zhudong Township, Hsinchu
County 310, Taiwan, R.O.C.
TEL: +886-3-582-8001 / FAX: +886-3-582-8958
Test Result : Complied

Documented By : 

(Carol Tsai / Senior Engineering Adm. Specialist)

Tested By : 

(Max Chang / Engineer)

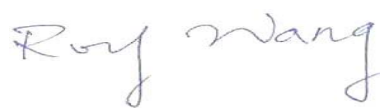
Approved By : 

(Roy Wang / Director)

Revision History

Report No.	Version	Description	Issued Date
1790307R-RFUSP01V00-A	V1.0	Initial issue of report	Oct. 20, 2017

TABLE OF CONTENTS

Description	Page
1. General Information.....	6
1.1. EUT Description	6
1.2. Test Mode	8
1.3. Tested System Details	9
1.4. Configuration of tested System	10
1.5. EUT Exercise Software	10
1.6. Test Facility	11
1.7. Duty Cycle	13
2. Conducted Emission	14
2.1. Test Equipment.....	14
2.2. Test Setup	14
2.3. Limits	14
2.4. Test Procedure	15
2.5. Test Specification.....	15
2.6. Uncertainty	15
2.7. Test Result.....	15
3. Peak Power Output	16
3.1. Test Equipment.....	16
3.2. Test Setup	16
3.3. Test procedures	16
3.4. Limits	17
3.5. Test Specification.....	17
3.6. Test Result.....	18
4. Radiated Emission	19
4.1. Test Equipment.....	19
4.2. Test Setup	20
4.3. Limits	21
4.4. Test Procedure	21
4.5. Test Specification.....	21
4.6. Test Result.....	22
5. RF antenna conducted test	64
5.1. Test Equipment.....	64
5.2. Test Setup	64
5.3. Limits	65
5.4. Test Procedure	65
5.5. Test Specification.....	65
5.6. Test Result.....	66
6. Band Edge.....	81
6.1. Test Equipment.....	81
6.2. Test Setup	81

6.3.	Limits	82
6.4.	Test Procedure	82
6.5.	Test Specification.....	82
6.6.	Test Result.....	83
7.	Number of hopping frequency	119
7.1.	Test Equipment.....	119
7.2.	Test Setup	119
7.3.	Limits	120
7.4.	Test Procedures	120
7.5.	Test Specification.....	120
7.6.	Test Result.....	121
8.	Carrier Frequency Separation	125
8.1.	Test Equipment.....	125
8.2.	Test Setup	125
8.3.	Limits	125
8.4.	Test Procedures	126
8.5.	Test Specification.....	126
8.6.	Test Result.....	127
9.	Occupied Bandwidth	136
9.1.	Test Equipment.....	136
9.2.	Test Setup	136
9.3.	Limits	137
9.4.	Test Procedures	137
9.5.	Test Specification.....	137
9.6.	Test Result.....	138
10.	Dwell Time.....	147
10.1.	Test Equipment.....	147
10.2.	Test Setup	147
10.3.	Limits	148
10.4.	Test Procedures	148
10.5.	Test Specification.....	148
10.6.	Test Result.....	149
Attachment 1		161
	Test Setup Photograph.....	161
Attachment 2		163
	EUT External Photograph.....	163
Attachment 3		167
	EUT Internal Photograph.....	167

1. General Information

1.1. EUT Description

Product Name	Multimedia System
Trade Name	Continental
Model No.	NAC EUR wave 3
Frequency Range/Channel Number	2402~2480MHz / 79 Channels
Type of Modulation	GFSK, $\pi/4$ -DQPSK, 8-DPSK

Antenna Information	
Antenna Type	Small Loop Antenna
Antenna Gain	-0.99 dBi

Working Frequency of Each Channel							
Channel	Frequency	Channel	Frequency	Channel	Frequency	Channel	Frequency
Channel 00	2402 MHz	Channel 20	2422 MHz	Channel 40	2442 MHz	Channel 60	2462 MHz
Channel 01	2403 MHz	Channel 21	2423 MHz	Channel 41	2443 MHz	Channel 61	2463 MHz
Channel 02	2404 MHz	Channel 22	2424 MHz	Channel 42	2444 MHz	Channel 62	2464 MHz
Channel 03	2405 MHz	Channel 23	2425 MHz	Channel 43	2445 MHz	Channel 63	2465 MHz
Channel 04	2406 MHz	Channel 24	2426 MHz	Channel 44	2446 MHz	Channel 64	2466 MHz
Channel 05	2407 MHz	Channel 25	2427 MHz	Channel 45	2447 MHz	Channel 65	2467 MHz
Channel 06	2408 MHz	Channel 26	2428 MHz	Channel 46	2448 MHz	Channel 66	2468 MHz
Channel 07	2409 MHz	Channel 27	2429 MHz	Channel 47	2449 MHz	Channel 67	2469 MHz
Channel 08	2410 MHz	Channel 28	2430 MHz	Channel 48	2450 MHz	Channel 68	2470 MHz
Channel 09	2411 MHz	Channel 29	2431 MHz	Channel 49	2451 MHz	Channel 69	2471 MHz
Channel 10	2412 MHz	Channel 30	2432 MHz	Channel 50	2452 MHz	Channel 70	2472 MHz
Channel 11	2413 MHz	Channel 31	2433 MHz	Channel 51	2453 MHz	Channel 71	2473 MHz
Channel 12	2414 MHz	Channel 32	2434 MHz	Channel 52	2454 MHz	Channel 72	2474 MHz
Channel 13	2415 MHz	Channel 33	2435 MHz	Channel 53	2455 MHz	Channel 73	2475 MHz
Channel 14	2416 MHz	Channel 34	2436 MHz	Channel 54	2456 MHz	Channel 74	2476 MHz
Channel 15	2417 MHz	Channel 35	2437 MHz	Channel 55	2457 MHz	Channel 75	2477 MHz
Channel 16	2418 MHz	Channel 36	2438 MHz	Channel 56	2458 MHz	Channel 76	2478 MHz
Channel 17	2419 MHz	Channel 37	2439 MHz	Channel 57	2459 MHz	Channel 77	2479 MHz
Channel 18	2420 MHz	Channel 38	2440 MHz	Channel 58	2460 MHz	Channel 78	2480 MHz
Channel 19	2421 MHz	Channel 39	2441 MHz	Channel 59	2461 MHz		

Note:

1. This device is a Multimedia System including 2.4GHz b/g/n and BT2.0 transmitting and receiving function.
2. Regards to the frequency band operation; the lowest , middle and highest frequency of channel were selected to perform the test, and then shown on this report.

1.2. Test Mode

DEKRA has verified the construction and function in typical operation. All the test modes were carried out with the EUT in transmitting operation, which was shown in this test report and defined as follows:

Test Mode	
TX	Mode 1: Transmit

Emission	Mode 1
Conducted Emission	No
Peak Power Output	Yes
Radiated Emission	Yes
RF antenna conducted test	Yes
Band Edge	Yes
Number of hopping Frequency	Yes
Carrier Frequency Separation	Yes
Occupied Bandwidth	Yes
Dwell Time	Yes

1.3. Tested System Details

The types for all equipment, plus descriptions of all cables used in the tested system (including inserted cards) are:

Product	Manufacturer	Model No.	Serial No.	FCC ID	Power Cord	
1	Notebook PC	DELL	Latitude 600	N/A	DoC	Non-Shielded, 1.7m, one ferrite core bonded
2	Battery	YUASA	NP7-12	N/A	DoC	--

1.4. Configuration of tested System

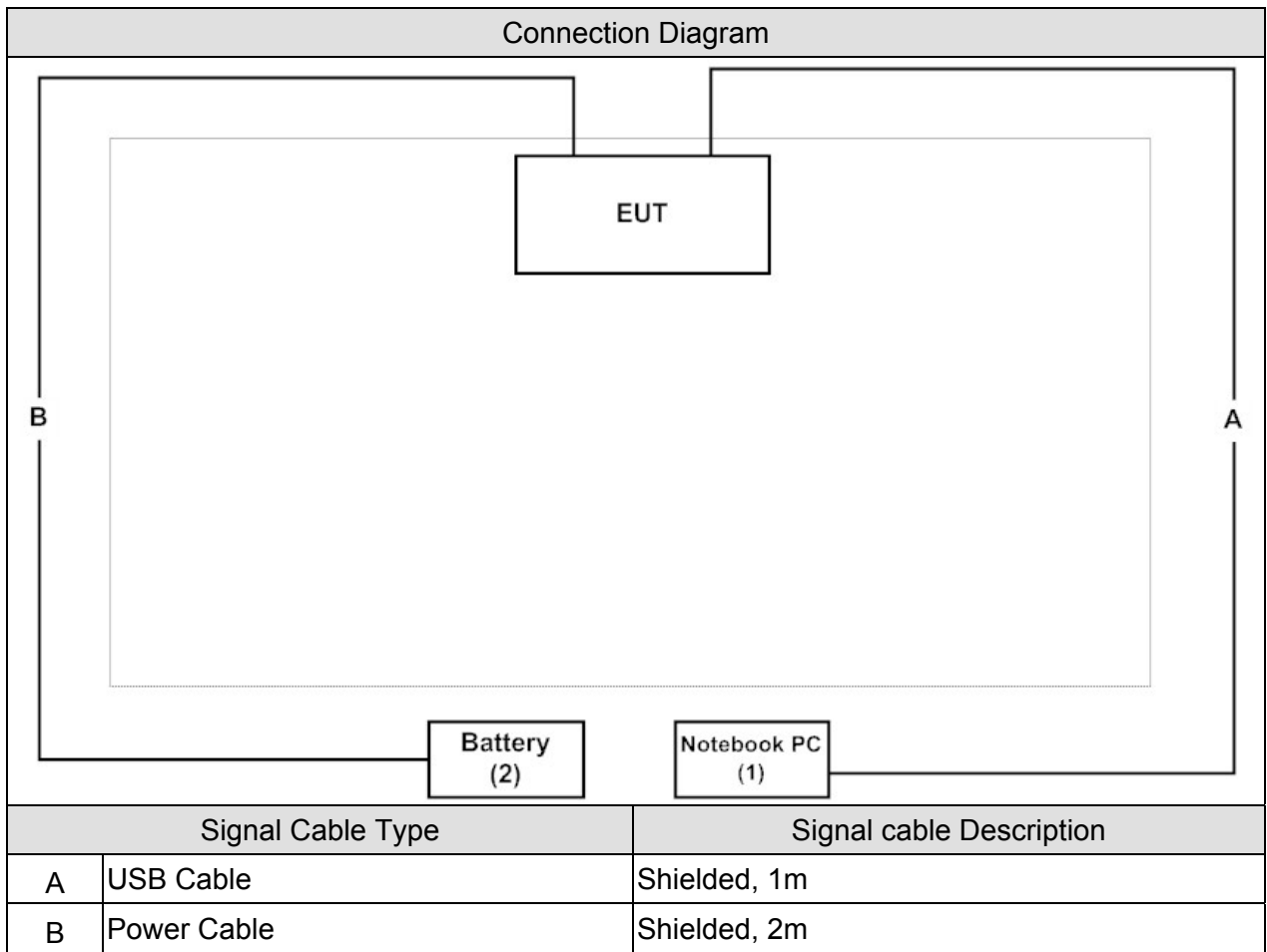

1.5. EUT Exercise Software

1	Setup the EUT as shown in Section 1.4.
2	Execute the test program "CSR".
3	Configure the test mode, the test channel, and the data rate.
4	Press "Start TX" to start the continuous transmitting.
5	Verify that the EUT works properly.

1.6. Test Facility

Ambient conditions in the laboratory:

Items	Test Item	Required (IEC 68-1)	Actual	Test Site
Temperature (°C)	FCC PART 15 C 15.207 Conducted Emission (FHSS)	15 - 35	23	--
Humidity (%RH)		25 - 75	50	
Barometric pressure (mbar)		860 - 1060	950-1000	
Temperature (°C)	FCC PART 15 C 15.247 Peak Power Output (FHSS)	15 - 35	24	3
Humidity (%RH)		25 - 75	45	
Barometric pressure (mbar)		860 - 1060	950-1000	
Temperature (°C)	FCC PART 15 C 15.247 Radiated Emission (FHSS)	15 - 35	25	2
Humidity (%RH)		25 - 75	54	
Barometric pressure (mbar)		860 - 1060	950-1000	
Temperature (°C)	FCC PART 15 C 15.247 Band Edge (FHSS)	15 - 35	25	2
Humidity (%RH)		25 - 75	50	
Barometric pressure (mbar)		860 - 1060	950-1000	
Temperature (°C)	FCC PART 15 C 15.247 Number of hopping Frequency (FHSS)	15 - 35	24	3
Humidity (%RH)		25 - 75	45	
Barometric pressure (mbar)		860 - 1060	950-1000	
Temperature (°C)	FCC PART 15 C 15.247 Carrier Frequency Separation (FHSS)	15 - 35	24	3
Humidity (%RH)		25 - 75	45	
Barometric pressure (mbar)		860 - 1060	950-1000	
Temperature (°C)	FCC PART 15 C 15.247 Occupied Bandwidth (FHSS)	15 - 35	24	3
Humidity (%RH)		25 - 75	45	
Barometric pressure (mbar)		860 - 1060	950-1000	
Temperature (°C)	FCC PART 15 C 15.247 RF antenna conducted test (FHSS)	15 - 35	24	3
Humidity (%RH)		25 - 75	45	
Barometric pressure (mbar)		860 - 1060	950-1000	
Temperature (°C)	FCC PART 15 C 15.247 Dwell Time (FHSS)	15 - 35	24	3
Humidity (%RH)		25 - 75	45	
Barometric pressure (mbar)		860 - 1060	950-1000	

Note: Test site information refers to Laboratory Information.

The related certificate for our laboratories about the test site and management system can be downloaded from DEKRA Testing and Certification Co., Ltd. Web Site :

<http://www.dekra.com.tw/english/about/certificates.aspx?bval=5>

The address and introduction of DEKRA Testing and Certification Co., Ltd. laboratories can be founded in our Web site : http://www.dekra.com.tw/index_en.aspx

If you have any comments, Please don't hesitate to contact us. Our test sites as below:

- 1 No. 75-2, 3rd Lin, WangYe Keng, Yonghxing Tsuen, Qionglin Shiang, Hsinchu County 307, Taiwan (R.O.C.)
TEL:+886-3-592-8858 / FAX:+886-3-592-8859 E-Mail : info.tw@dekra.com
- 2 No.372, Sec. 4, Zhongxing Rd., Zhudong Township, Hsinchu County 310, Taiwan, R.O.C.
TEL: +886-3-582-8001 / FAX: +886-3-582-8958 E-Mail : info.tw@dekra.com
- 3 No.372-2, Sec. 4, Zhongxing Rd., Zhudong Township, Hsinchu County 310, Taiwan, R.O.C.
TEL: +886-3-582-8001 / FAX: +886-3-582-8958 E-Mail : info.tw@dekra.com

1.7. Duty Cycle

Duty Cycle=2.895msec /3.75msec=0.772

Duty Cycle correction factor= 20 LOG 0.772= -2.248 dB

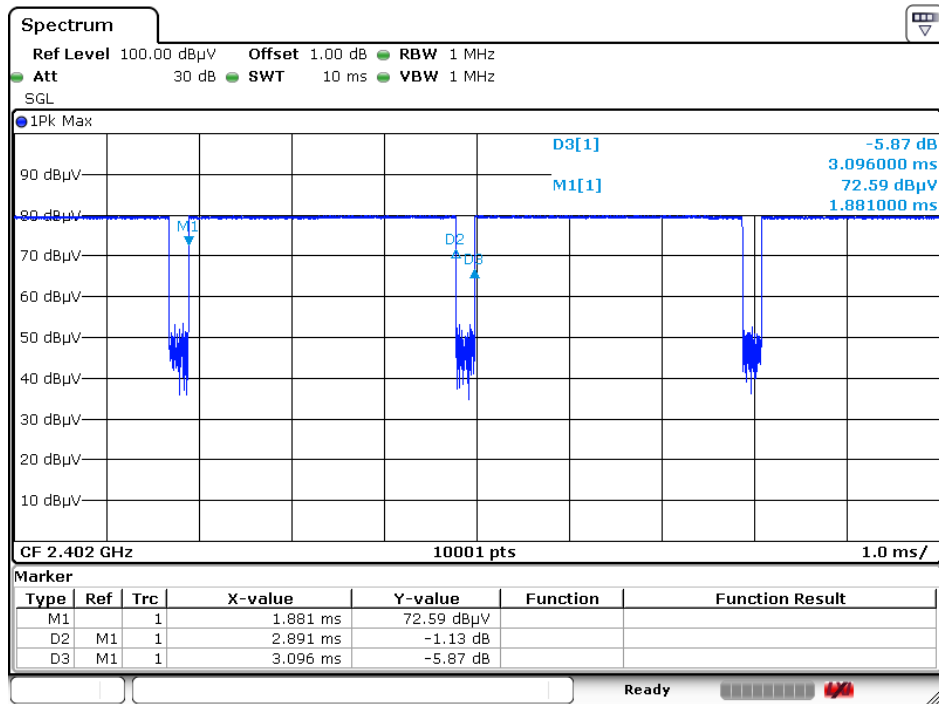

Date: 24.SEP.2017 15:05:53

2. Conducted Emission

2.1. Test Equipment

The following test equipment's are used during the test:

Conducted Emission / SR2-H

Instrument	Manufacturer	Model No.	Serial No	Next Cal. Date
Artificial Mains Network	R&S	ENV4200	848411/010	2017/02/06
Test Receiver	R&S	ESCS 30	836858/022	2017/04/12
LISN	R&S	ENV216	100092	2017/07/31

Note: All equipment that need to calibrate are with calibration period of 1 year.

2.2. Test Setup

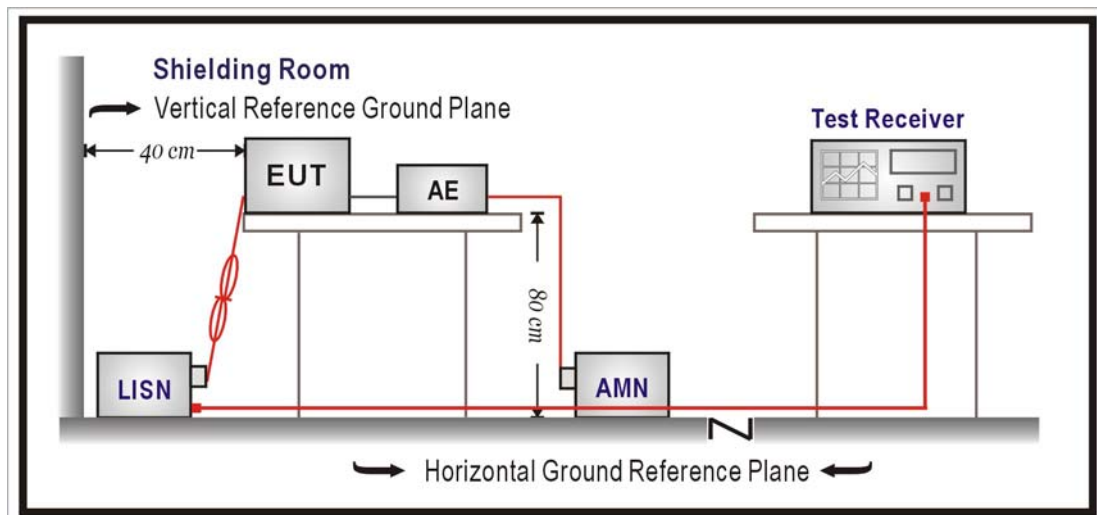

2.3. Limits

FCC Part 15 Subpart C Paragraph 15.207 Limits (dBuV)		
Frequency MHz	QP	AV
0.15 - 0.50	66-56	56-46
0.50 - 5.0	56	46
5.0 - 30	60	50

Remarks: In the above table, the tighter limit applies at the band edges.

2.4. Test Procedure

The EUT and simulators are connected to the main power through a line impedance stabilization network (L.I.S.N.). This provides a 50 ohm /50uH coupling impedance for the measuring equipment. The peripheral devices are also connected to the main power through a LISN that provides a 50ohm /50uH coupling impedance with 50ohm termination. (Please refer to the block diagram of the test setup and photographs.)

Both sides of A.C. line are checked for maximum conducted interference. In order to find the maximum emission, the relative positions of equipment and all of the interface cables must be changed according to ANSI C63.10:2009 on conducted measurement.

Conducted emissions were investigated over the frequency range from 0.15MHz to 30MHz using a receiver bandwidth of 9 kHz.

2.5. Test Specification

According to FCC Part 15 Subpart C Paragraph 15.207: 2015

2.6. Uncertainty

The measurement uncertainty is defined as ± 2.26 dB.

2.7. Test Result

EUT using DC input voltage, so the project does not have to test.

3. Peak Power Output

3.1. Test Equipment

The following test equipment is used during the test:

Peak Power Output / SR10-H

Instrument	Manufacturer	Model No.	Serial No	Next Cal. Date
Signal & Spectrum Analyzer	R&S	FSV40	101049	2017/01/23
EXA Signal Analyzer	Keysight	N9010A	MY51440132	2017/03/13
High Speed Peak Power Meter Dual Input	Anritsu	ML2496A	1602004	2017/01/20
Pulse Power Sensor	Anritsu	MA2411B	1531043	2017/01/20
Pulse Power Sensor	Anritsu	MA2411B	1531044	2017/01/20

Note: All equipment upon which need to calibrated are with calibration period of 1 year.

3.2. Test Setup

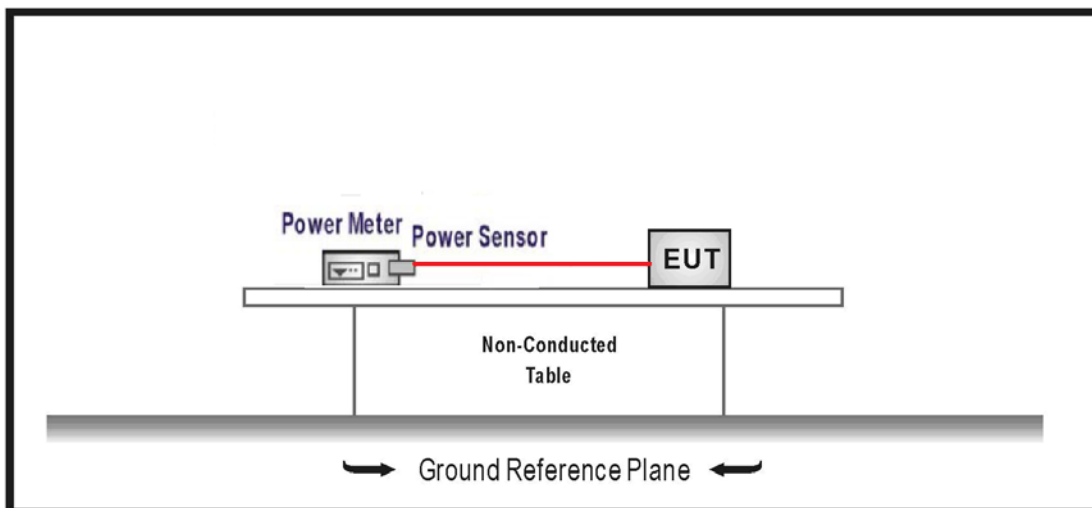

3.3. Test procedures

The EUT was setup according to ANSI C63.10:2013 and tested according to FHSS test procedure of FCC Public Notice DA 00-705 for compliance to FCC 47CFR 15.247 requirements

3.4. Limits

For frequency hopping systems operating in the 902-928 MHz band: 1 Watt for systems employing at least 50 hopping channels; and, 0.25 Watts for systems employing less than 50 hopping channels.

For frequency hopping systems in the 2400-2483.5 MHz band employing at least 75 hopping channels, and all frequency hopping systems in the 5725-5850 MHz band: 1Watt.

For all other frequency hopping systems in the 2400-2483.5 MHz band: 0.125 Watt.

3.5. Test Specification

According to FCC Part 15 Subpart C Paragraph 15.247: 2015.

3.6. Test Result

Product	Multimedia System		
Test Item	Peak Power Output		
Test Mode	Mode 1: Transmit		
Date of Test	2017/09/27	Test Site	SR10-H

GFSK

Channel No.	Frequency (MHz)	Measure Level (dBm)	Limit (dBm)	Result
00	2402	4.390	30	Pass
39	2441	4.730	30	Pass
78	2480	5.090	30	Pass

$\pi/4$ -DQPSK

Channel No.	Frequency (MHz)	Measure Level (dBm)	Limit (dBm)	Result
00	2402	4.400	30	Pass
39	2441	4.740	30	Pass
78	2480	5.110	30	Pass

8-DPSK

Channel No.	Frequency (MHz)	Measure Level (dBm)	Limit (dBm)	Result
00	2402	4.410	30	Pass
39	2441	4.720	30	Pass
78	2480	5.100	30	Pass

4. Radiated Emission

4.1. Test Equipment

The following test equipment are used during the test:

Radiated Emission / CB4-H

Instrument	Manufacturer	Model No.	Serial No	Next Cal. Date
Signal Analyzer	R&S	FSVA40	101455	2016/11/28
Signal & Spectrum Analyzer	R&S	FSV40	101049	2017/01/23
EXA Signal Analyzer	Keysight	N9010A	MY51440132	2017/03/13
Bilog Antenna	Teseq	CBL6112D	23191	2017/06/28
Horn Antenna	Schwarzbeck	BBHA 9120D	639	2017/06/14
Horn Antenna	Schwarzbeck	BBHA 9170	202	2017/02/15
Pre-Amplifier	RF Bay Inc.	LNA-1330	12162511	2017/03/09
Pre-Amplifier	EMCI	EMCI 1830I	980366	2017/01/23
Pre-Amplifier	MITEQ	JS44-45-8P	2014754	2016/12/26

Note: All equipment's that need to calibrate are with calibration period of 1 year.

4.2. Test Setup

Under 1GHz Test Setup:

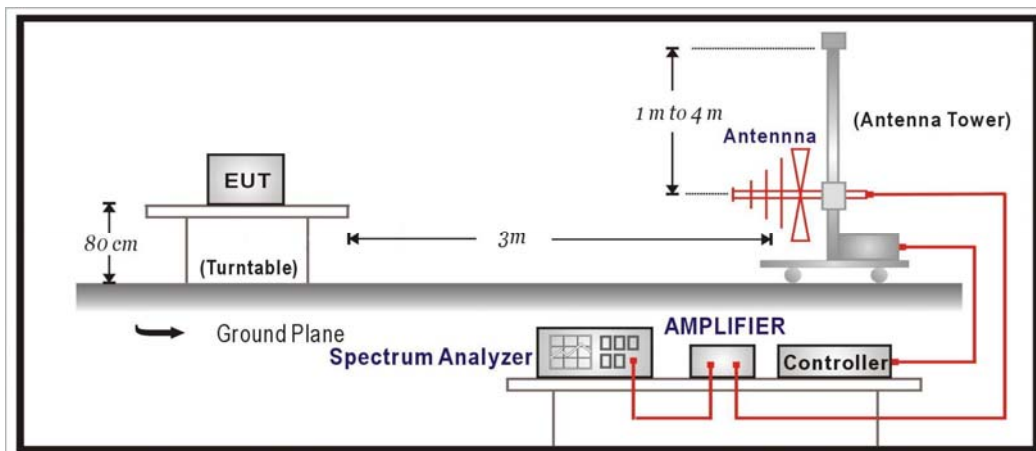

Above 1GHz Test Setup:

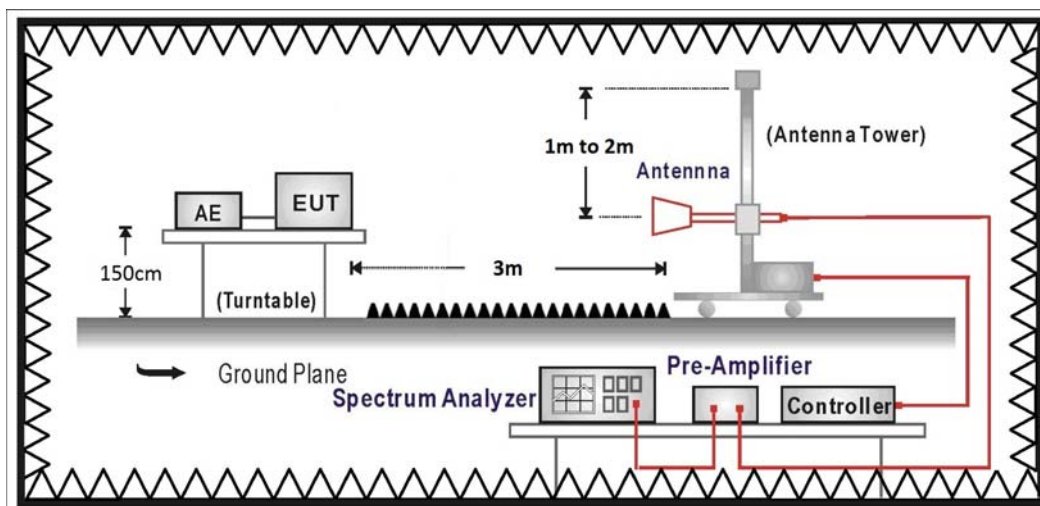

4.3. Limits

Emissions radiated outside of the specified frequency bands, except for harmonics, shall be attenuated by at least 20dB below the level of the fundamental or to the general radiated emission limits in paragraph 15.209, whichever is the lesser attenuation.

FCC Part 15 Subpart C Paragraph 15.209 Limits		
Frequency MHz	uV/m	dBuV/m
30-88	100	40
88-216	150	43.5
216-960	200	46
Above 960	500	54

Remarks : 1. RF Voltage (dBuV) = 20 log RF Voltage (uV)

2. In the Above Table, the tighter limit applies at the band edges.

3. Distance refers to the distance in meters between the measuring instrument antenna and the closed point of any part of the device or system.

4.4. Test Procedure

The EUT was setup according to ANSI C63.10:2013 and tested according to FHSS test procedure of FCC Public Notice DA 00-705 for compliance to FCC 47CFR 15.247 requirements.

The EUT and its simulators are placed on a turn table which is 0.8 or 1.5 meter above ground. The turn table can rotate 360 degrees to determine the position of the maximum emission level.

The antenna can move up and down between 1 meter and 4 meters to find out the maximum emission level.

Both horizontal and vertical polarization of the antenna are set on measurement. In order to find the maximum emission, all of the interface cables must be manipulated according to ANSI C63.10:2013 on radiated measurement.

On any frequency or frequencies below or equal to 1000 MHz, the limits shown are based on measuring equipment employing a quasi-peak detector function and on any frequency or frequencies above 1000 MHz the radiated limits shown are based upon the use of measurement instrumentation employing an average detector function. When average radiated emission measurement are included emission measurement below 1000 MHz, there also is a limit on the radio frequency emissions, as measured using instrumentation with a peak detector function, corresponding to 20 dB above the maximum permitted average limit. The bandwidth below 1GHz setting on the field strength meter is 120 kHz and above 1GHz is 1MHz.

4.5. Test Specification

According to FCC Part 15 Subpart C Paragraph 15.247: 2015

4.6. Test Result

30MHz-1GHz Spurious

Site : CB4-H	Time : 2017/10/06
Limit : FCC_CLASS_B_03M_QP	Margin : 6
Probe : CB4-H_FCCFC_EFS_S2_30M-1GHz_1116 - HORIZONTAL	Power : DC 12V
EUT : Multimedia System	Note : DH5_2441MHz

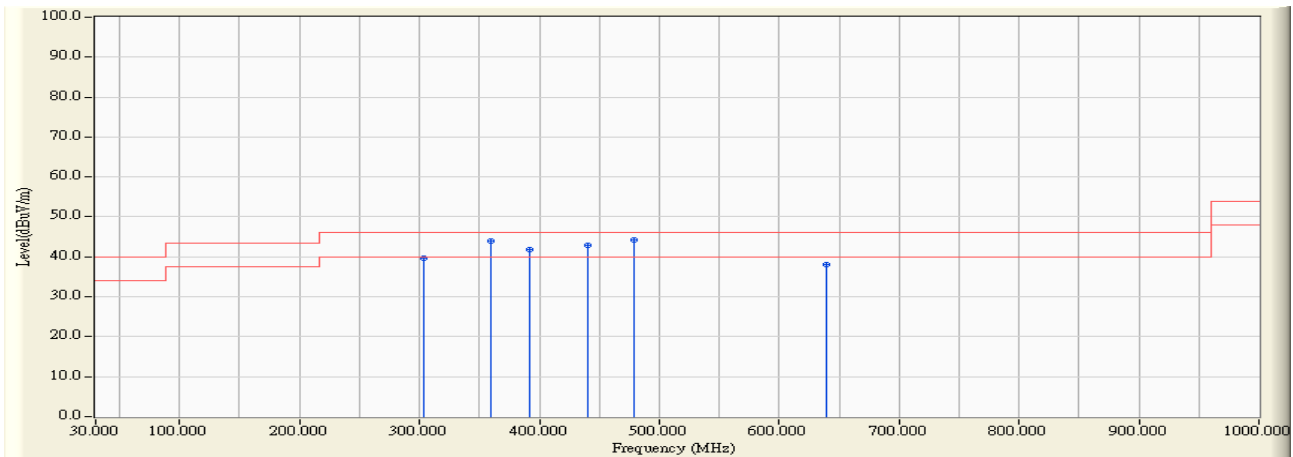

	Frequency (MHz)	Correct Factor (dB)	Reading Level (dBuV)	Measure Level (dBuV/m)	Margin (dB)	Limit (dBuV/m)	Detector Type
1	303.217	-19.645	59.206	39.561	-6.439	46.000	QUASPEAK
2	359.800	-17.555	61.522	43.968	-2.032	46.000	QUASPEAK
3	392.133	-16.489	58.287	41.798	-4.202	46.000	QUASPEAK
4	440.633	-15.660	58.494	42.834	-3.166	46.000	QUASPEAK
5	* 479.433	-14.697	58.858	44.161	-1.839	46.000	QUASPEAK
6	639.483	-12.731	50.745	38.013	-7.987	46.000	QUASPEAK

Note:

1. All Reading Levels are Quasi-Peak value.
2. “ * ”, means this data is the worst emission level.
3. Measurement Level = Reading Level + Correct Factor

Site : CB4-H	Time : 2017/10/06
Limit : FCC_CLASS_B_03M_QP	Margin : 6
Probe : CB4-H_FCCCC_EFS_S2_30M-1GHz_1116 - VERTICAL	Power : DC 12V
EUT : Multimedia System	Note : DH5_2441MHz

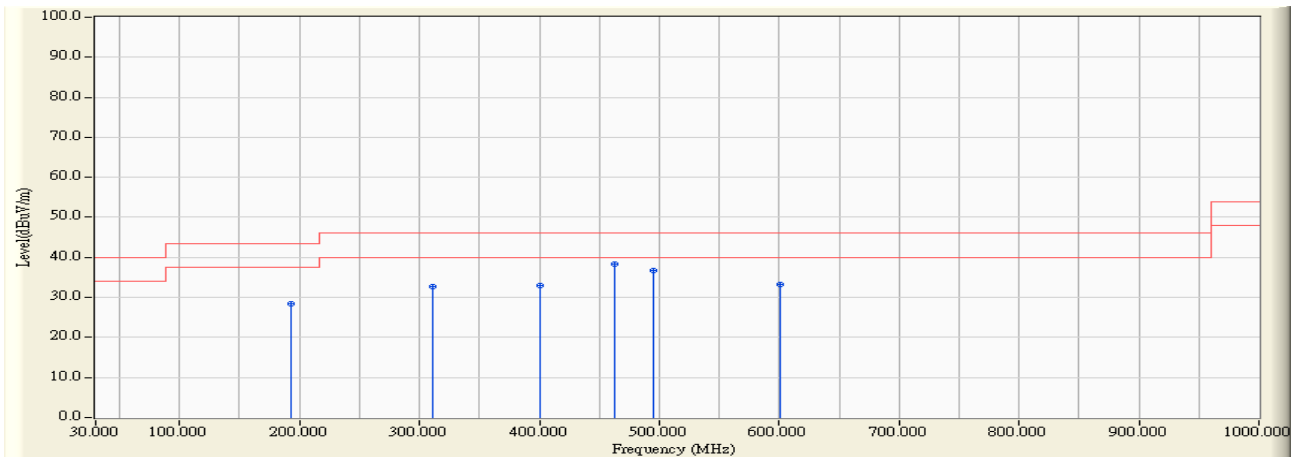

	Frequency (MHz)	Correct Factor (dB)	Reading Level (dBuV)	Measure Level (dBuV/m)	Margin (dB)	Limit (dBuV/m)	Detector Type
1	193.283	-23.607	52.037	28.431	-15.069	43.500	QUASPEAK
2	311.300	-19.173	51.981	32.809	-13.191	46.000	QUASPEAK
3	400.217	-16.224	49.151	32.927	-13.073	46.000	QUASPEAK
4	* 463.267	-15.200	53.466	38.266	-7.734	46.000	QUASPEAK
5	495.600	-14.474	51.222	36.749	-9.251	46.000	QUASPEAK
6	600.683	-13.146	46.340	33.194	-12.806	46.000	QUASPEAK

Note:

1. All Reading Levels are Quasi-Peak value.
2. “ * ”, means this data is the worst emission level.
3. Measurement Level = Reading Level + Correct Factor

Site : CB4-H	Time : 2017/10/06
Limit : FCC_CLASS_B_03M_QP	Margin : 6
Probe : CB4-H_FCCFC_EFS_S2_30M-1GHz_1116 - HORIZONTAL	Power : DC 12V
EUT : Multimedia System	Note : 2DH5_2441MHz

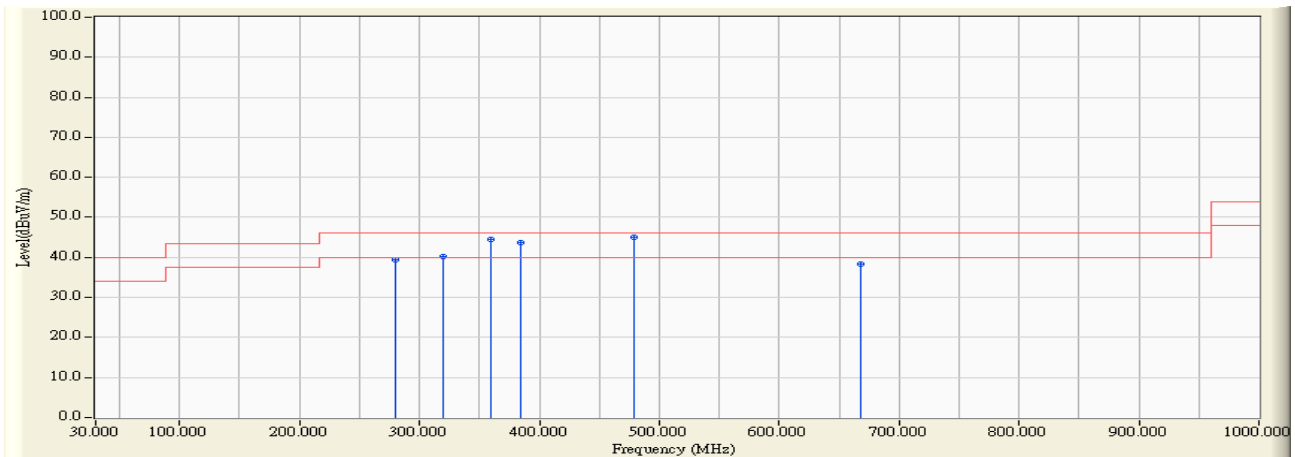

	Frequency (MHz)	Correct Factor (dB)	Reading Level (dBuV)	Measure Level (dBuV/m)	Margin (dB)	Limit (dBuV/m)	Detector Type
1	280.583	-19.874	59.290	39.417	-6.583	46.000	QUASPEAK
2	319.383	-18.683	59.006	40.323	-5.677	46.000	QUASPEAK
3	359.800	-17.555	62.096	44.542	-1.458	46.000	QUASPEAK
4	384.050	-16.792	60.418	43.626	-2.374	46.000	QUASPEAK
5	* 479.433	-14.697	59.812	45.115	-0.885	46.000	QUASPEAK
6	668.583	-12.418	50.707	38.288	-7.712	46.000	QUASPEAK

Note:

1. All Reading Levels are Quasi-Peak value.
2. “ * ”, means this data is the worst emission level.
3. Measurement Level = Reading Level + Correct Factor

Site : CB4-H	Time : 2017/10/06
Limit : FCC_CLASS_B_03M_QP	Margin : 6
Probe : CB4-H_FCCFC_EFS_S2_30M-1GHz_1116 - VERTICAL	Power : DC 12V
EUT : Multimedia System	Note : 2DH5_2441MHz

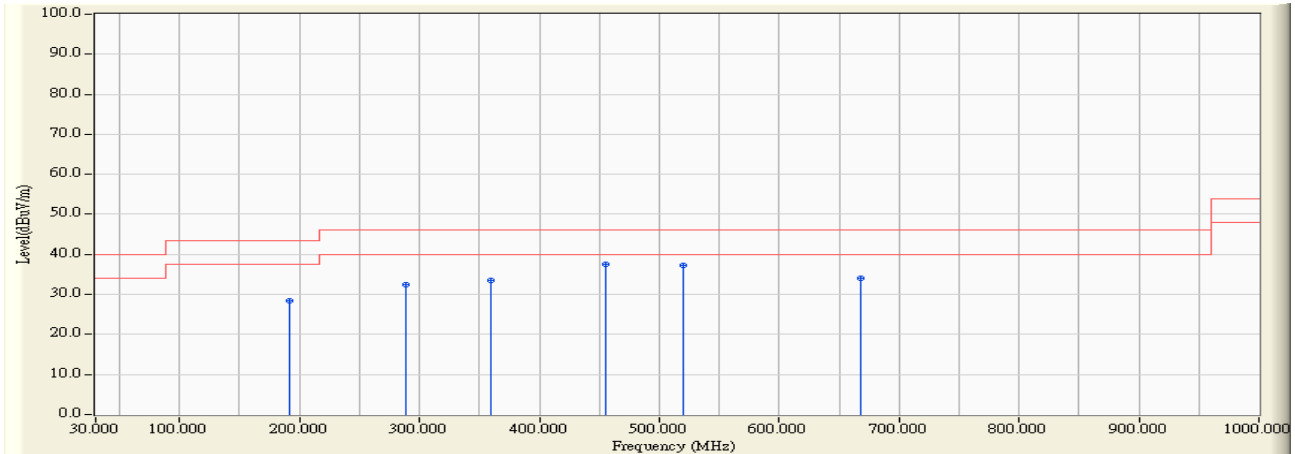

	Frequency (MHz)	Correct Factor (dB)	Reading Level (dBuV)	Measure Level (dBuV/m)	Margin (dB)	Limit (dBuV/m)	Detector Type
1	191.667	-23.662	52.133	28.472	-15.028	43.500	QUASIPeAK
2	288.667	-19.731	52.287	32.556	-13.444	46.000	QUASIPeAK
3	359.800	-17.555	51.052	33.498	-12.502	46.000	QUASIPeAK
4	* 455.183	-15.229	52.630	37.401	-8.599	46.000	QUASIPeAK
5	519.850	-14.245	51.441	37.196	-8.804	46.000	QUASIPeAK
6	668.583	-12.418	46.460	34.041	-11.959	46.000	QUASIPeAK

Note:

1. All Reading Levels are Quasi-Peak value.
2. “ * ”, means this data is the worst emission level.
3. Measurement Level = Reading Level + Correct Factor

Site : CB4-H	Time : 2017/10/06
Limit : FCC_CLASS_B_03M_QP	Margin : 6
Probe : CB4-H_FCCCF_EFS_S2_30M-1GHz_1116 - HORIZONTAL	Power : DC 12V
EUT : Multimedia System	Note : 3DH5_2441MHz

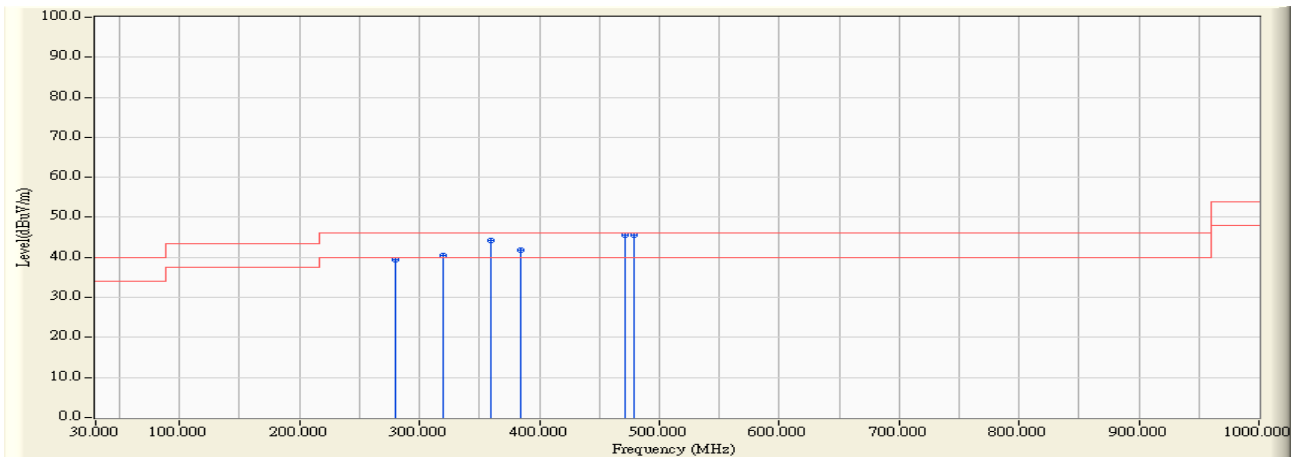

	Frequency (MHz)	Correct Factor (dB)	Reading Level (dBuV)	Measure Level (dBuV/m)	Margin (dB)	Limit (dBuV/m)	Detector Type
1	280.583	-19.874	59.275	39.402	-6.598	46.000	QUASPEAK
2	319.383	-18.683	59.076	40.393	-5.607	46.000	QUASPEAK
3	359.800	-17.555	61.913	44.359	-1.641	46.000	QUASPEAK
4	384.050	-16.792	58.661	41.869	-4.131	46.000	QUASPEAK
5	* 471.350	-14.978	60.548	45.570	-0.430	46.000	QUASPEAK
6	479.433	-14.697	60.246	45.549	-0.451	46.000	QUASPEAK

Note:

1. All Reading Levels are Quasi-Peak value.
2. “ * ”, means this data is the worst emission level.
3. Measurement Level = Reading Level + Correct Factor

Site : CB4-H	Time : 2017/10/06
Limit : FCC_CLASS_B_03M_QP	Margin : 6
Probe : CB4-H_FCCFC_EFS_S2_30M-1GHz_1116 - VERTICAL	Power : DC 12V
EUT : Multimedia System	Note : 3DH5_2441MHz

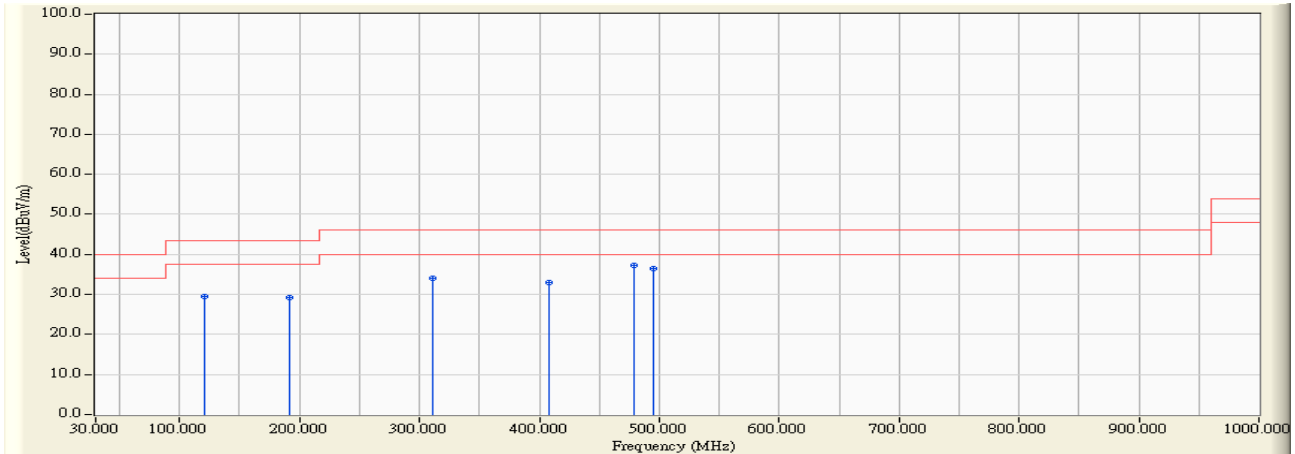

	Frequency (MHz)	Correct Factor (dB)	Reading Level (dBuV)	Measure Level (dBuV/m)	Margin (dB)	Limit (dBuV/m)	Detector Type
1	120.533	-21.084	50.443	29.359	-14.141	43.500	QUASPEAK
2	191.667	-23.662	52.757	29.096	-14.404	43.500	QUASPEAK
3	311.300	-19.173	53.293	34.121	-11.879	46.000	QUASPEAK
4	408.300	-16.335	49.322	32.988	-13.012	46.000	QUASPEAK
5	* 479.433	-14.697	52.048	37.351	-8.649	46.000	QUASPEAK
6	495.600	-14.474	50.879	36.406	-9.594	46.000	QUASPEAK

Note:

1. All Reading Levels are Quasi-Peak value.
2. “ * ”, means this data is the worst emission level.
3. Measurement Level = Reading Level + Correct Factor

Harmonic & Spurious:

Site : CB4-H	Time : 2017/09/26
Limit : FCC_SpartC_15.209_03M_PK	Margin : 6
Probe : CB4-H_FCCCC_A115_EFS_1-18GHz_1116 - HORIZONTAL	Power : DC 12V
EUT : Multimedia System	Note : DH5_2402MHz

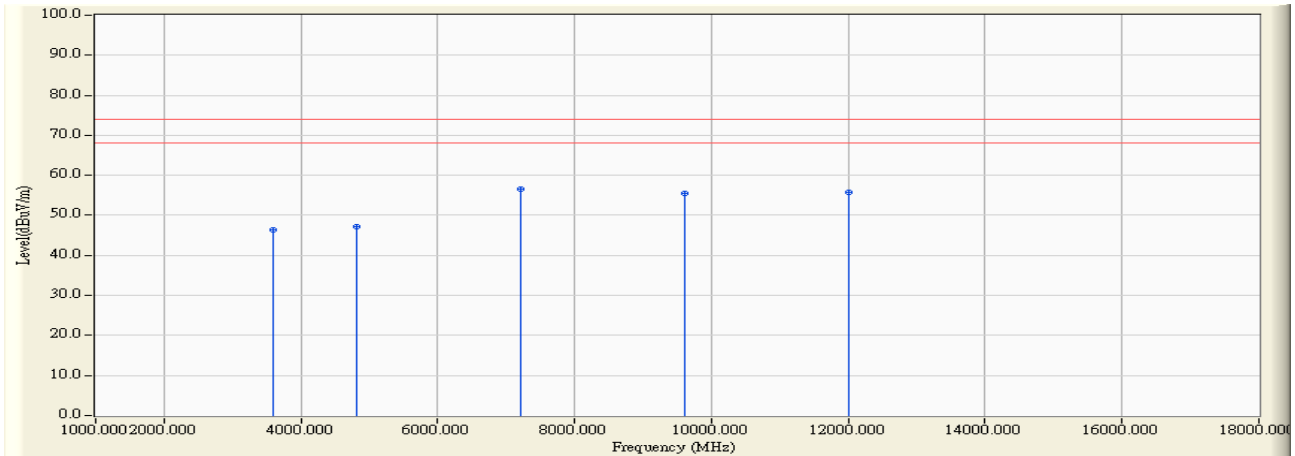

	Frequency (MHz)	Correct Factor (dB)	Reading Level (dBuV)	Measure Level (dBuV/m)	Margin (dB)	Limit (dBuV/m)	Detector Type
1	3603.065	3.295	43.100	46.395	-27.605	74.000	PEAK
2	4804.217	8.276	38.810	47.086	-26.914	74.000	PEAK
3	* 7205.650	17.857	38.690	56.547	-17.453	74.000	PEAK
4	9607.285	22.459	32.980	55.438	-18.562	74.000	PEAK
5	12009.412	25.360	30.290	55.650	-18.350	74.000	PEAK

Note:

1. All readings above 1GHz are performed with peak and/or average measurements as necessary.
2. Peak measurements: RBW = 1MHz, VBW = 1MHz, Sweep: Auto.
3. Average measurements: RBW = 1MHz, VBW = 10 Hz, Sweep: Auto.
4. “ * ”, means this data is the worst emission level.
5. Measurement Level = Reading Level + Correct Factor.
6. The average measurement was not performed when the peak measured data under the limit of average detection
7. This Emission test range from 1GHz to 25GHz, but above 13GHz were not included because their levels are too low.

Site : CB4-H	Time : 2017/09/26
Limit : FCC_SpartC_15.209_03M_AV	Margin : 6
Probe : CB4-H_FCC_C_A115_EFS_1-18GHz_1116 - HORIZONTAL	Power : DC 12V
EUT : Multimedia System	Note : DH5_2402MHz

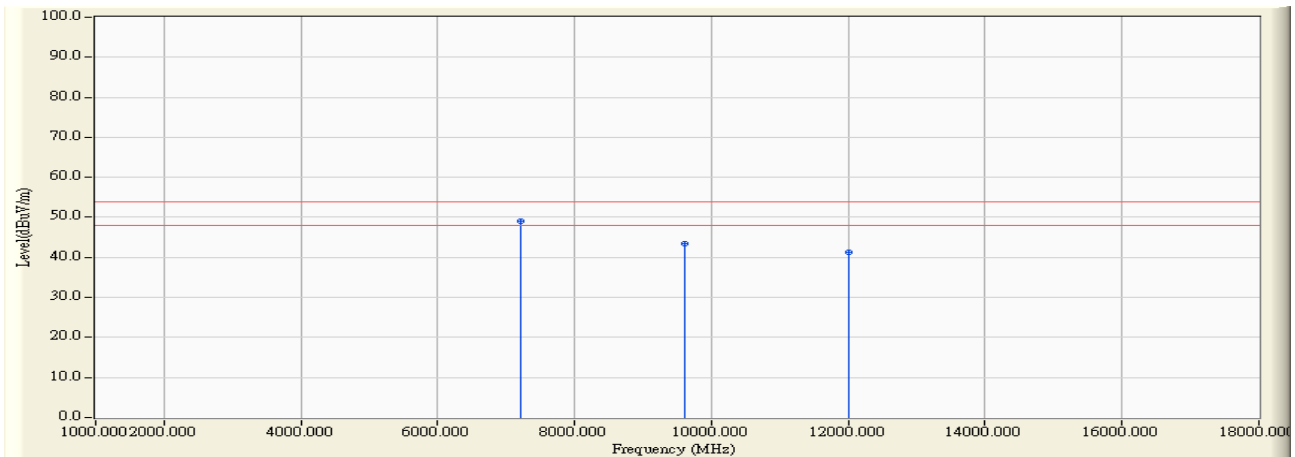

		Frequency (MHz)	Correct Factor (dB)	Reading Level (dBuV)	Measure Level (dBuV/m)	Margin (dB)	Limit (dBuV/m)	Detector Type
1	*	7205.650	17.857	31.260	49.117	-4.883	54.000	AVERAGE
2		9607.285	22.459	21.060	43.518	-10.482	54.000	AVERAGE
3		12009.412	25.360	15.950	41.310	-12.690	54.000	AVERAGE

Note:

1. All readings above 1GHz are performed with peak and/or average measurements as necessary.
2. Peak measurements: RBW = 1MHz, VBW = 1MHz, Sweep: Auto.
3. Average measurements: RBW = 1MHz, VBW = 10 Hz, Sweep: Auto.
4. “ * ”, means this data is the worst emission level.
5. Measurement Level = Reading Level + Correct Factor.
6. The average measurement was not performed when the peak measured data under the limit of average detection.
7. This Emission test range from 1GHz to 25GHz, but above 13GHz were not included because their levels are too low.

Site : CB4-H	Time : 2017/09/26
Limit : FCC_SpartC_15.209_03M_PK	Margin : 6
Probe : CB4-H_FCCCC_A115_EFS_1-18GHz_1116 - VERTICAL	Power : DC 12V
EUT : Multimedia System	Note : DH5_2402MHz

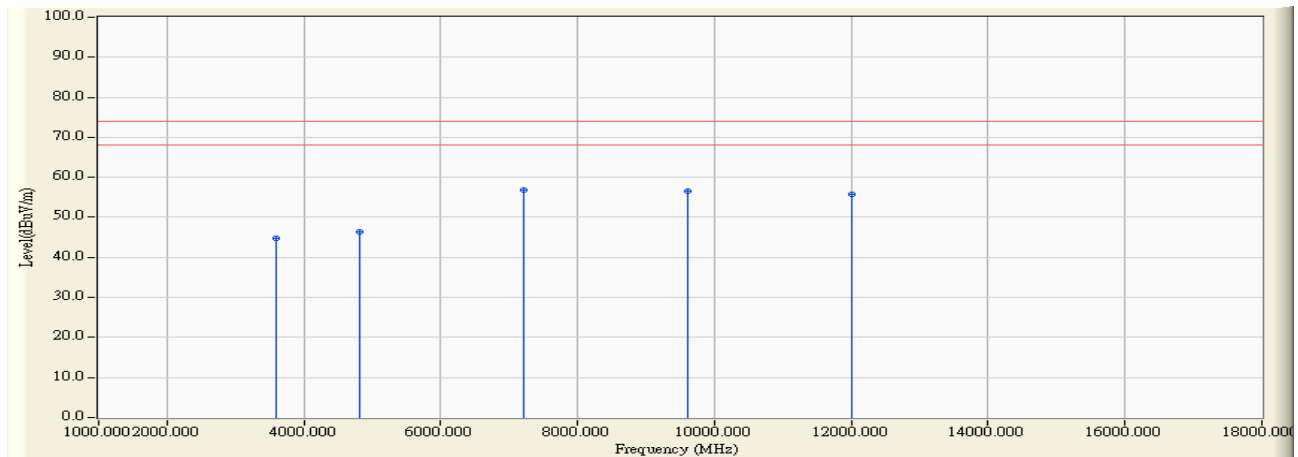

	Frequency (MHz)	Correct Factor (dB)	Reading Level (dBuV)	Measure Level (dBuV/m)	Margin (dB)	Limit (dBuV/m)	Detector Type
1	3602.750	3.294	41.440	44.734	-29.266	74.000	PEAK
2	4803.780	8.273	38.180	46.454	-27.546	74.000	PEAK
3	* 7206.460	17.860	38.860	56.719	-17.281	74.000	PEAK
4	9607.062	22.458	34.030	56.488	-17.512	74.000	PEAK
5	12011.012	25.360	30.380	55.740	-18.260	74.000	PEAK

Note:

1. All readings above 1GHz are performed with peak and/or average measurements as necessary.
2. Peak measurements: RBW = 1MHz, VBW = 1MHz, Sweep: Auto.
3. Average measurements: RBW = 1MHz, VBW = 10 Hz, Sweep: Auto.
4. “ * ”, means this data is the worst emission level.
5. Measurement Level = Reading Level + Correct Factor.
6. The average measurement was not performed when the peak measured data under the limit of average detection.
7. This Emission test range from 1GHz to 25GHz, but above 13GHz were not included because their levels are too low.

Site : CB4-H	Time : 2017/09/26
Limit : FCC_SpartC_15.209_03M_AV	Margin : 6
Probe : CB4-H_FCCFC_A115_EFS_1-18GHz_1116 - VERTICAL	Power : DC 12V
EUT : Multimedia System	Note : DH5_2402MHz

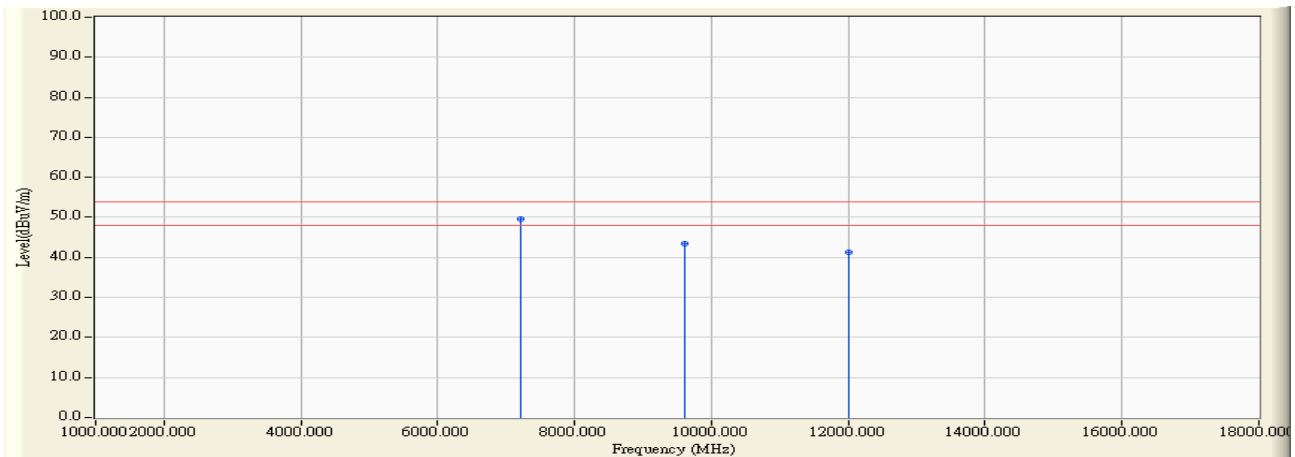

		Frequency (MHz)	Correct Factor (dB)	Reading Level (dBuV)	Measure Level (dBuV/m)	Margin (dB)	Limit (dBuV/m)	Detector Type
1	*	7206.460	17.860	31.760	49.619	-4.381	54.000	AVERAGE
2		9607.942	22.461	20.950	43.411	-10.589	54.000	AVERAGE
3		12011.012	25.360	15.920	41.280	-12.720	54.000	AVERAGE

Note:

1. All readings above 1GHz are performed with peak and/or average measurements as necessary.
2. Peak measurements: RBW = 1MHz, VBW = 1MHz, Sweep: Auto.
3. Average measurements: RBW = 1MHz, VBW = 10 Hz, Sweep: Auto.
4. “ * ”, means this data is the worst emission level.
5. Measurement Level = Reading Level + Correct Factor.
6. The average measurement was not performed when the peak measured data under the limit of average detection.
7. This Emission test range from 1GHz to 25GHz, but above 13GHz were not included because their levels are too low.

Site : CB4-H	Time : 2017/09/26
Limit : FCC_SpartC_15.209_03M_PK	Margin : 6
Probe : CB4-H_FCCCC_A115_EFS_1-18GHz_1116 - HORIZONTAL	Power : DC 12V
EUT : Multimedia System	Note : DH5_2441MHz

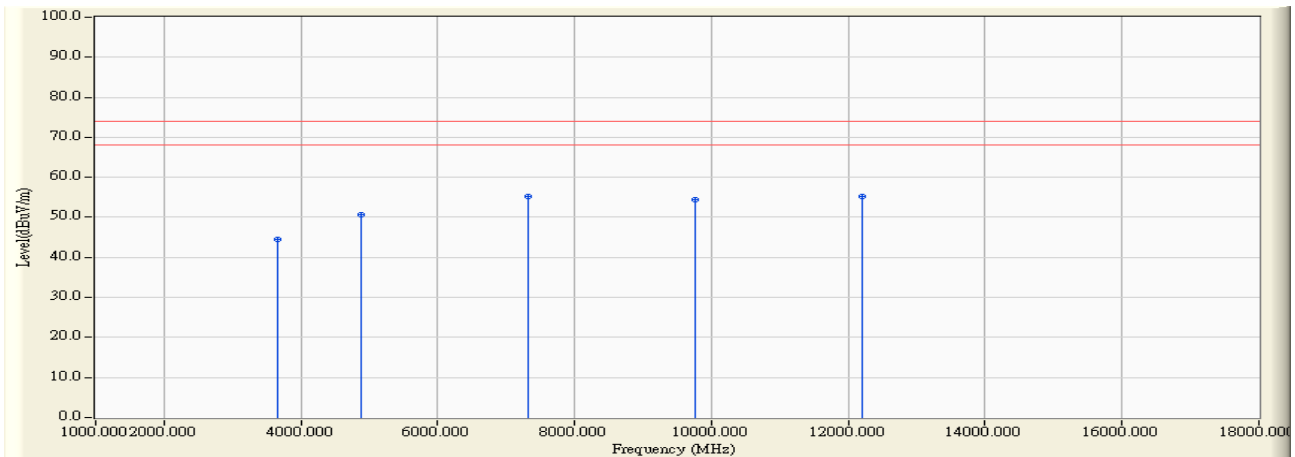

	Frequency (MHz)	Correct Factor (dB)	Reading Level (dBuV)	Measure Level (dBuV/m)	Margin (dB)	Limit (dBuV/m)	Detector Type
1	3661.145	3.488	40.940	44.428	-29.572	74.000	PEAK
2	4881.890	8.670	42.070	50.740	-23.260	74.000	PEAK
3	7323.572	18.129	37.010	55.140	-18.860	74.000	PEAK
4	9764.495	23.087	31.450	54.536	-19.464	74.000	PEAK
5	* 12206.310	25.500	29.650	55.150	-18.850	74.000	PEAK

Note:

1. All readings above 1GHz are performed with peak and/or average measurements as necessary.
2. Peak measurements: RBW = 1MHz, VBW = 1MHz, Sweep: Auto.
3. Average measurements: RBW = 1MHz, VBW = 10 Hz, Sweep: Auto.
4. “ * ”, means this data is the worst emission level.
5. Measurement Level = Reading Level + Correct Factor.
6. The average measurement was not performed when the peak measured data under the limit of average detection.
7. This Emission test range from 1GHz to 25GHz, but above 13GHz were not included because their levels are too low.

Site : CB4-H	Time : 2017/09/26
Limit : FCC_SpartC_15.209_03M_AV	Margin : 6
Probe : CB4-H_FCCCC_A115_EFS_1-18GHz_1116 - HORIZONTAL	Power : DC 12V
EUT : Multimedia System	Note : DH5_2441MHz

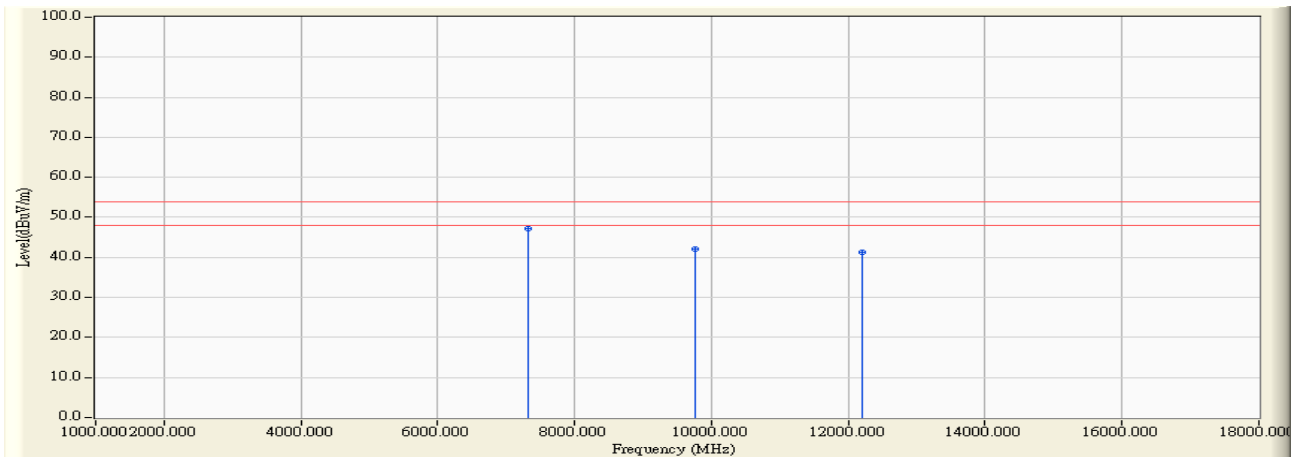

		Frequency (MHz)	Correct Factor (dB)	Reading Level (dBuV)	Measure Level (dBuV/m)	Margin (dB)	Limit (dBuV/m)	Detector Type
1	*	7323.572	18.129	29.030	47.160	-6.840	54.000	AVERAGE
2		9764.495	23.087	18.960	42.046	-11.954	54.000	AVERAGE
3		12206.310	25.500	15.700	41.200	-12.800	54.000	AVERAGE

Note:

1. All readings above 1GHz are performed with peak and/or average measurements as necessary.
2. Peak measurements: RBW = 1MHz, VBW = 1MHz, Sweep: Auto.
3. Average measurements: RBW = 1MHz, VBW = 10 Hz, Sweep: Auto.
4. “ * ”, means this data is the worst emission level.
5. Measurement Level = Reading Level + Correct Factor.
6. The average measurement was not performed when the peak measured data under the limit of average detection.
7. This Emission test range from 1GHz to 25GHz, but above 13GHz were not included because their levels are too low.

Site : CB4-H	Time : 2017/09/26
Limit : FCC_SpartC_15.209_03M_PK	Margin : 6
Probe : CB4-H_FCCCC_A115_EFS_1-18GHz_1116 - VERTICAL	Power : DC 12V
EUT : Multimedia System	Note : DH5_2441MHz

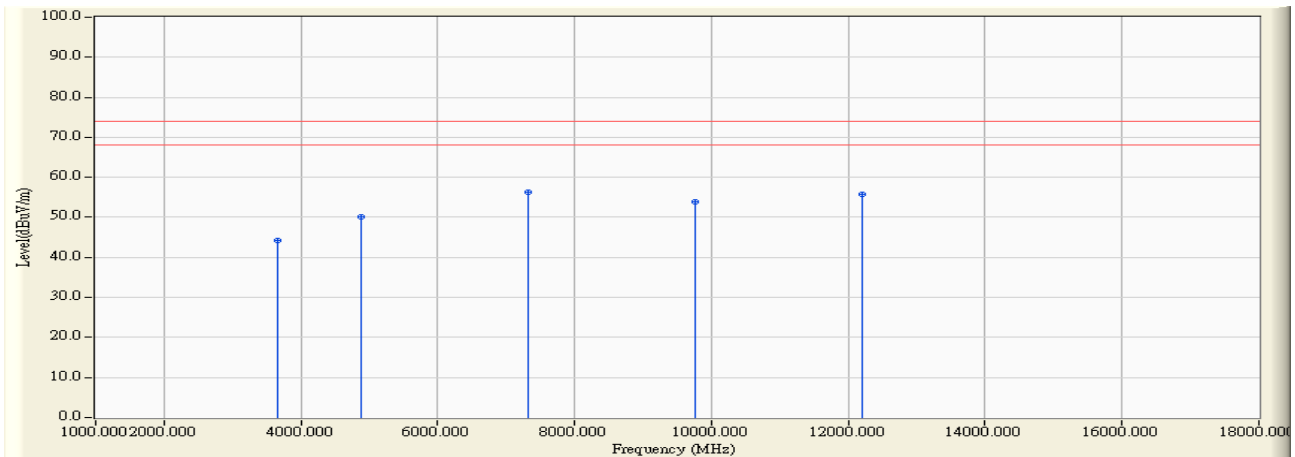

	Frequency (MHz)	Correct Factor (dB)	Reading Level (dBuV)	Measure Level (dBuV/m)	Margin (dB)	Limit (dBuV/m)	Detector Type
1	3661.015	3.488	40.620	44.108	-29.892	74.000	PEAK
2	4881.660	8.669	41.580	50.249	-23.751	74.000	PEAK
3	* 7323.445	18.129	38.110	56.240	-17.760	74.000	PEAK
4	9763.745	23.083	30.720	53.804	-20.196	74.000	PEAK
5	12205.412	25.499	30.290	55.789	-18.211	74.000	PEAK

Note:

1. All readings above 1GHz are performed with peak and/or average measurements as necessary.
2. Peak measurements: RBW = 1MHz, VBW = 1MHz, Sweep: Auto.
3. Average measurements: RBW = 1MHz, VBW = 10 Hz, Sweep: Auto.
4. “ * ”, means this data is the worst emission level.
5. Measurement Level = Reading Level + Correct Factor.
6. The average measurement was not performed when the peak measured data under the limit of average detection.
7. This Emission test range from 1GHz to 25GHz, but above 13GHz were not included because their levels are too low.

Site : CB4-H	Time : 2017/09/26
Limit : FCC_SpartC_15.209_03M_AV	Margin : 6
Probe : CB4-H_FCC_C_A115_EFS_1-18GHz_1116 - VERTICAL	Power : DC 12V
EUT : Multimedia System	Note : DH5_2441MHz

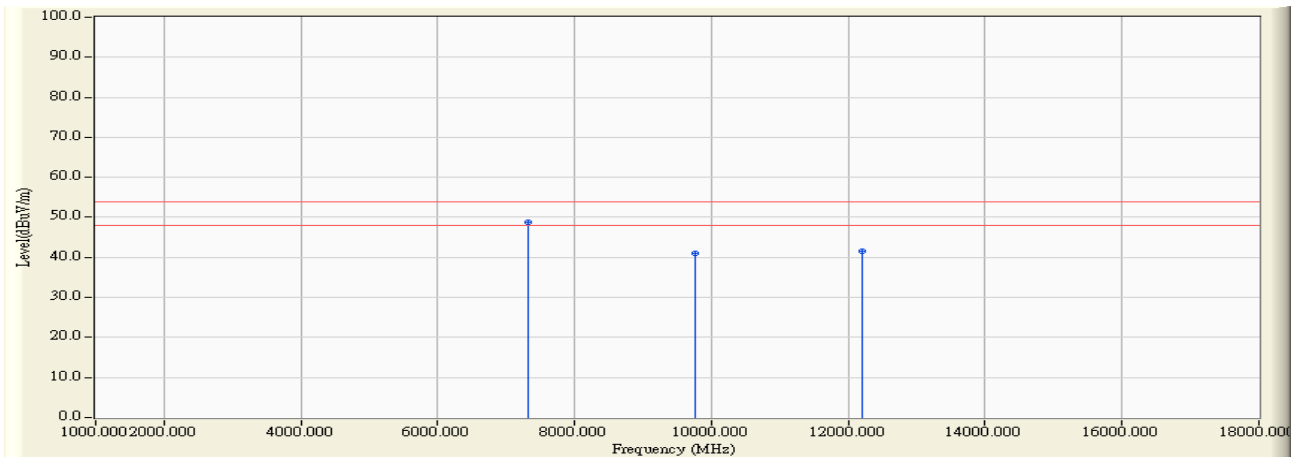

		Frequency (MHz)	Correct Factor (dB)	Reading Level (dBuV)	Measure Level (dBuV/m)	Margin (dB)	Limit (dBuV/m)	Detector Type
1	*	7323.015	18.129	30.660	48.789	-5.211	54.000	AVERAGE
2		9763.745	23.083	17.900	40.984	-13.016	54.000	AVERAGE
3		12205.412	25.499	15.930	41.429	-12.571	54.000	AVERAGE

Note:

1. All readings above 1GHz are performed with peak and/or average measurements as necessary.
2. Peak measurements: RBW = 1MHz, VBW = 1MHz, Sweep: Auto.
3. Average measurements: RBW = 1MHz, VBW = 10 Hz, Sweep: Auto.
4. “ * ”, means this data is the worst emission level.
5. Measurement Level = Reading Level + Correct Factor.
6. The average measurement was not performed when the peak measured data under the limit of average detection.
7. This Emission test range from 1GHz to 25GHz, but above 13GHz were not included because their levels are too low.

Site : CB4-H	Time : 2017/09/26
Limit : FCC_SpartC_15.209_03M_PK	Margin : 6
Probe : CB4-H_FCCCC_A115_EFS_1-18GHz_1116 - HORIZONTAL	Power : DC 12V
EUT : Multimedia System	Note : DH5_2480MHz

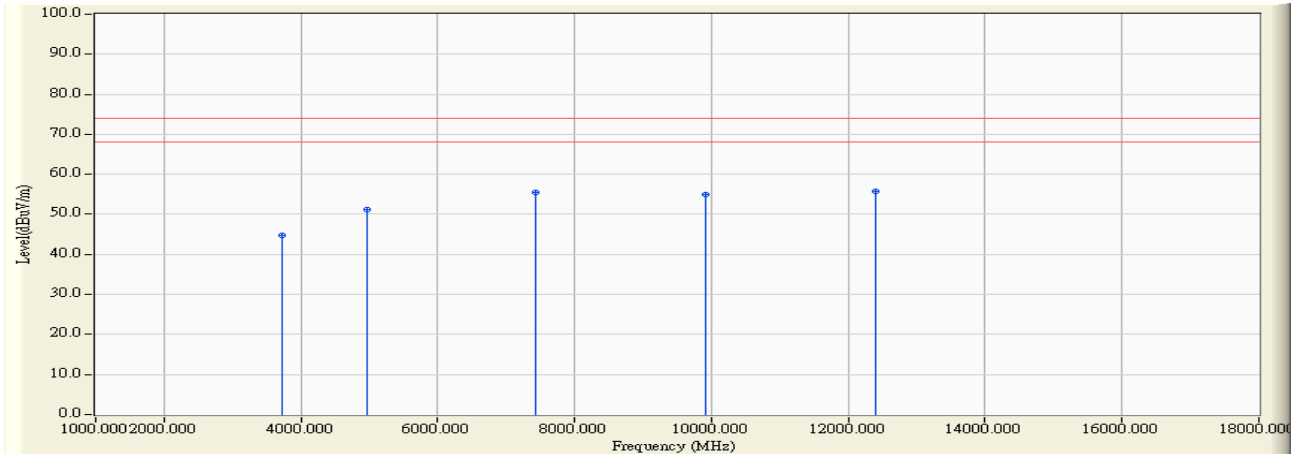

	Frequency (MHz)	Correct Factor (dB)	Reading Level (dBuV)	Measure Level (dBuV/m)	Margin (dB)	Limit (dBuV/m)	Detector Type
1	3720.342	3.685	41.080	44.765	-29.235	74.000	PEAK
2	4959.947	9.066	42.090	51.156	-22.844	74.000	PEAK
3	7440.340	18.380	37.210	55.591	-18.409	74.000	PEAK
4	9919.837	23.616	31.250	54.866	-19.134	74.000	PEAK
5	* 12400.712	25.649	30.160	55.808	-18.192	74.000	PEAK

Note:

1. All readings above 1GHz are performed with peak and/or average measurements as necessary.
2. Peak measurements: RBW = 1MHz, VBW = 1MHz, Sweep: Auto.
3. Average measurements: RBW = 1MHz, VBW = 10 Hz, Sweep: Auto.
4. “ * ”, means this data is the worst emission level.
5. Measurement Level = Reading Level + Correct Factor.
6. The average measurement was not performed when the peak measured data under the limit of average detection.
7. This Emission test range from 1GHz to 25GHz, but above 13GHz were not included because their levels are too low.

Site : CB4-H	Time : 2017/09/26
Limit : FCC_SpartC_15.209_03M_AV	Margin : 6
Probe : CB4-H_FCC_C_A115_EFS_1-18GHz_1116 - HORIZONTAL	Power : DC 12V
EUT : Multimedia System	Note : DH5_2480MHz

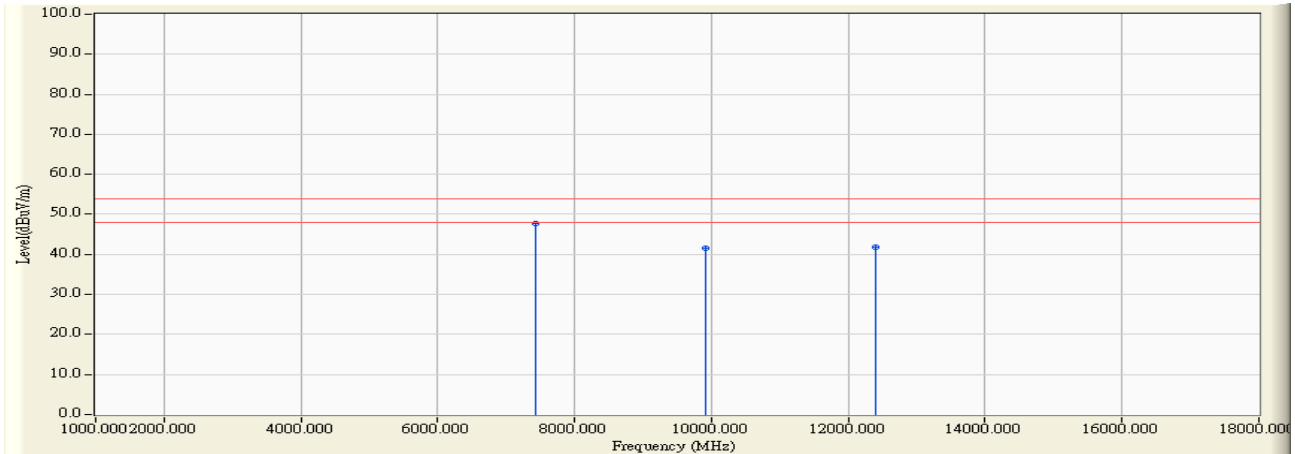

		Frequency (MHz)	Correct Factor (dB)	Reading Level (dBuV)	Measure Level (dBuV/m)	Margin (dB)	Limit (dBuV/m)	Detector Type
1	*	7440.340	18.380	29.280	47.661	-6.339	54.000	AVERAGE
2		9919.837	23.616	18.060	41.676	-12.324	54.000	AVERAGE
3		12400.712	25.649	16.290	41.938	-12.062	54.000	AVERAGE

Note:

1. All readings above 1GHz are performed with peak and/or average measurements as necessary.
2. Peak measurements: RBW = 1MHz, VBW = 1MHz, Sweep: Auto.
3. Average measurements: RBW = 1MHz, VBW = 10 Hz, Sweep: Auto.
4. “ * ”, means this data is the worst emission level.
5. Measurement Level = Reading Level + Correct Factor.
6. The average measurement was not performed when the peak measured data under the limit of average detection.
7. This Emission test range from 1GHz to 25GHz, but above 13GHz were not included because their levels are too low.

Site : CB4-H	Time : 2017/09/26
Limit : FCC_SpartC_15.209_03M_PK	Margin : 6
Probe : CB4-H_FCCCC_A115_EFS_1-18GHz_1116 - VERTICAL	Power : DC 12V
EUT : Multimedia System	Note : DH5_2480MHz

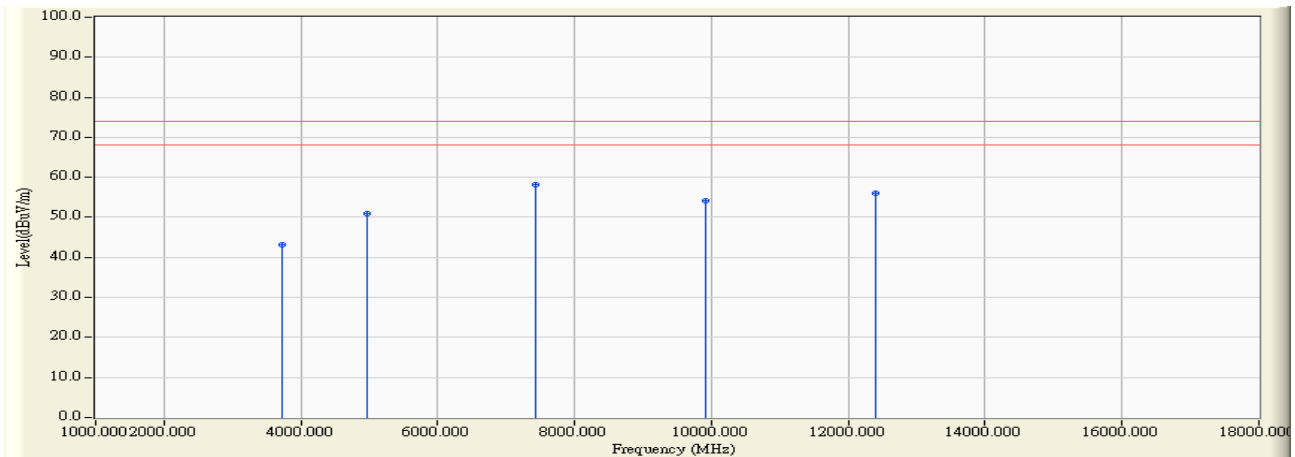

	Frequency (MHz)	Correct Factor (dB)	Reading Level (dBuV)	Measure Level (dBuV/m)	Margin (dB)	Limit (dBuV/m)	Detector Type
1	3719.465	3.682	39.370	43.052	-30.948	74.000	PEAK
2	4960.222	9.068	41.740	50.808	-23.192	74.000	PEAK
3	* 7440.355	18.380	39.800	58.181	-15.819	74.000	PEAK
4	9920.032	23.616	30.490	54.106	-19.894	74.000	PEAK
5	12400.417	25.648	30.260	55.908	-18.092	74.000	PEAK

Note:

1. All readings above 1GHz are performed with peak and/or average measurements as necessary.
2. Peak measurements: RBW = 1MHz, VBW = 1MHz, Sweep: Auto.
3. Average measurements: RBW = 1MHz, VBW = 10 Hz, Sweep: Auto.
4. “ * ”, means this data is the worst emission level.
5. Measurement Level = Reading Level + Correct Factor.
6. The average measurement was not performed when the peak measured data under the limit of average detection.
7. This Emission test range from 1GHz to 25GHz, but above 13GHz were not included because their levels are too low.

Site : CB4-H	Time : 2017/09/26
Limit : FCC_SpartC_15.209_03M_AV	Margin : 6
Probe : CB4-H_FCC_C_A115_EFS_1-18GHz_1116 - VERTICAL	Power : DC 12V
EUT : Multimedia System	Note : DH5_2480MHz

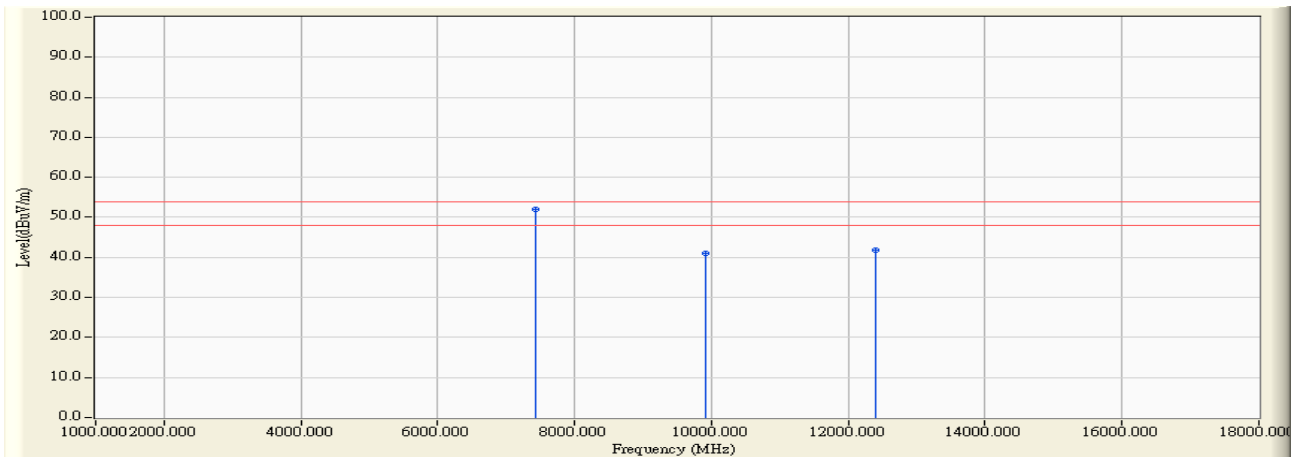

		Frequency (MHz)	Correct Factor (dB)	Reading Level (dBuV)	Measure Level (dBuV/m)	Margin (dB)	Limit (dBuV/m)	Detector Type
1	*	7440.355	18.380	33.550	51.931	-2.069	54.000	AVERAGE
2		9920.120	23.616	17.400	41.017	-12.983	54.000	AVERAGE
3		12400.417	25.648	16.130	41.778	-12.222	54.000	AVERAGE

Note:

1. All readings above 1GHz are performed with peak and/or average measurements as necessary.
2. Peak measurements: RBW = 1MHz, VBW = 1MHz, Sweep: Auto.
3. Average measurements: RBW = 1MHz, VBW = 10 Hz, Sweep: Auto.
4. “ * ”, means this data is the worst emission level.
5. Measurement Level = Reading Level + Correct Factor.
6. The average measurement was not performed when the peak measured data under the limit of average detection.
7. This Emission test range from 1GHz to 25GHz, but above 13GHz were not included because their levels are too low.

Site : CB4-H	Time : 2017/09/26
Limit : FCC_SpartC_15.209_03M_PK	Margin : 6
Probe : CB4-H_FCCCC_A115_EFS_1-18GHz_1116 - HORIZONTAL	Power : DC 12V
EUT : Multimedia System	Note : 2DH5_2402MHz

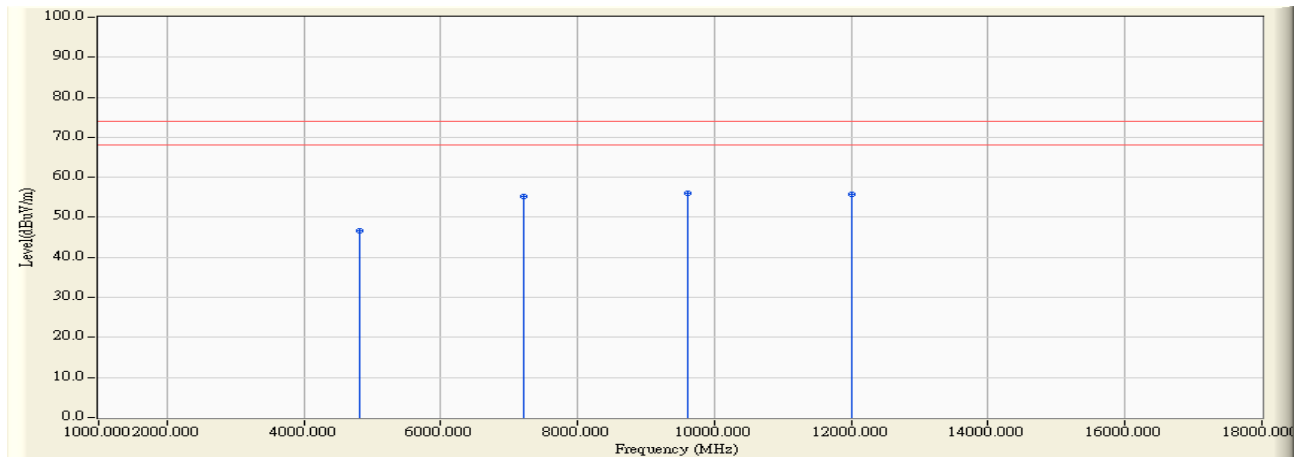

	Frequency (MHz)	Correct Factor (dB)	Reading Level (dBuV)	Measure Level (dBuV/m)	Margin (dB)	Limit (dBuV/m)	Detector Type
1	4804.270	8.276	38.250	46.527	-27.473	74.000	PEAK
2	7206.217	17.858	37.400	55.259	-18.741	74.000	PEAK
3	* 9607.245	22.458	33.480	55.938	-18.062	74.000	PEAK
4	12009.630	25.360	30.350	55.710	-18.290	74.000	PEAK

Note:

1. All readings above 1GHz are performed with peak and/or average measurements as necessary.
2. Peak measurements: RBW = 1MHz, VBW = 1MHz, Sweep: Auto.
3. Average measurements: RBW = 1MHz, VBW = 10 Hz, Sweep: Auto.
4. “ * ”, means this data is the worst emission level.
5. Measurement Level = Reading Level + Correct Factor.
6. The average measurement was not performed when the peak measured data under the limit of average detection.
7. This Emission test range from 1GHz to 25GHz, but above 13GHz were not included because their levels are too low.

Site : CB4-H	Time : 2017/09/26
Limit : FCC_SpartC_15.209_03M_AV	Margin : 6
Probe : CB4-H_FCCCC_A115_EFS_1-18GHz_1116 - HORIZONTAL	Power : DC 12V
EUT : Multimedia System	Note : 2DH5_2402MHz

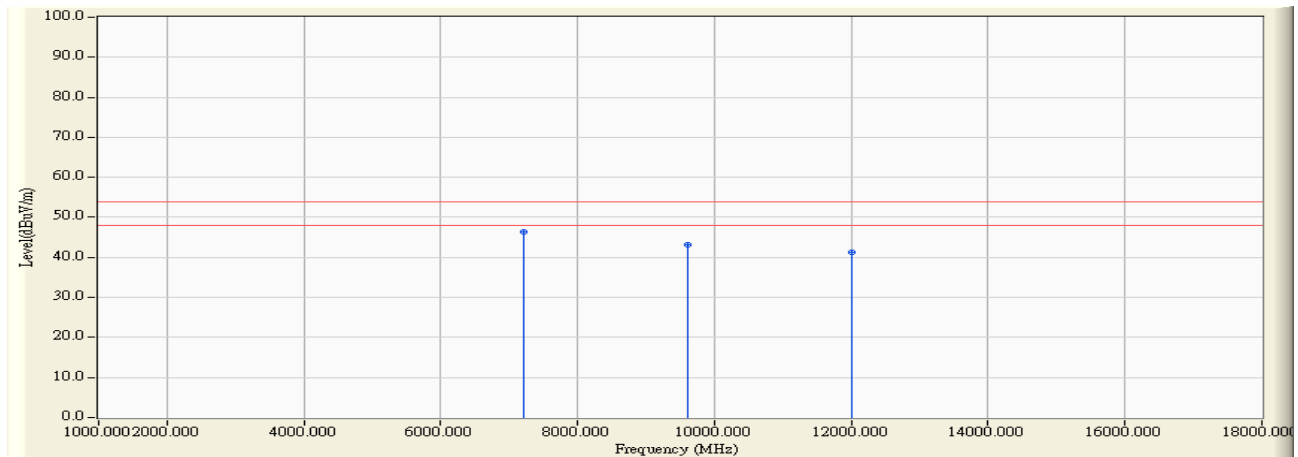

		Frequency (MHz)	Correct Factor (dB)	Reading Level (dBuV)	Measure Level (dBuV/m)	Margin (dB)	Limit (dBuV/m)	Detector Type
1	*	7206.217	17.858	28.510	46.369	-7.631	54.000	AVERAGE
2		9607.245	22.458	20.780	43.238	-10.762	54.000	AVERAGE
3		12009.630	25.360	15.800	41.160	-12.840	54.000	AVERAGE

Note:

1. All readings above 1GHz are performed with peak and/or average measurements as necessary.
2. Peak measurements: RBW = 1MHz, VBW = 1MHz, Sweep: Auto.
3. Average measurements: RBW = 1MHz, VBW = 10 Hz, Sweep: Auto.
4. “ * ”, means this data is the worst emission level.
5. Measurement Level = Reading Level + Correct Factor.
6. The average measurement was not performed when the peak measured data under the limit of average detection.
7. This Emission test range from 1GHz to 25GHz, but above 13GHz were not included because their levels are too low.

Site : CB4-H	Time : 2017/09/26
Limit : FCC_SpartC_15.209_03M_PK	Margin : 6
Probe : CB4-H_FCC_C_A115_EFS_1-18GHz_1116 - VERTICAL	Power : DC 12V
EUT : Multimedia System	Note : 2DH5_2402MHz

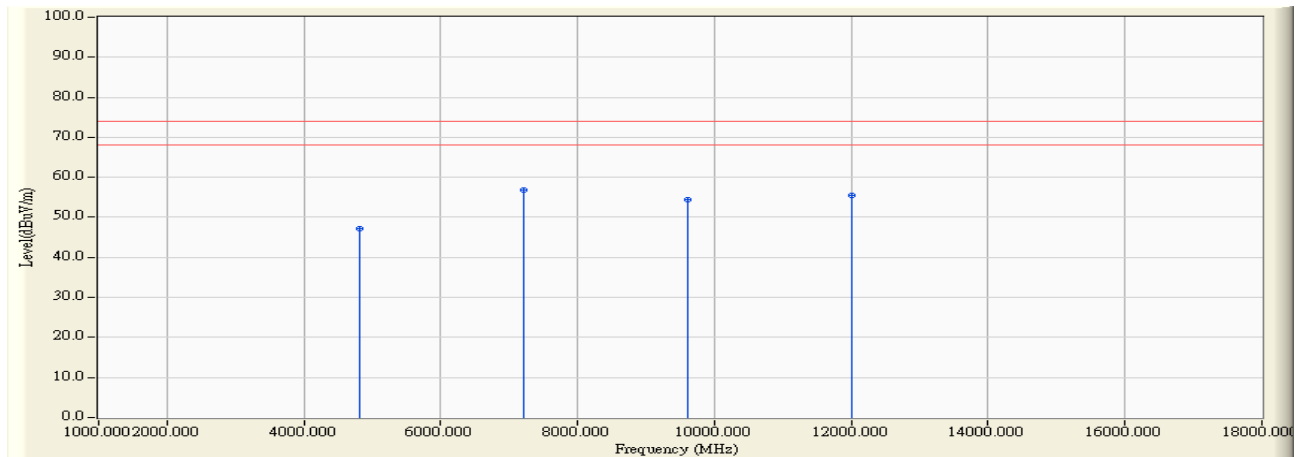

	Frequency (MHz)	Correct Factor (dB)	Reading Level (dBuV)	Measure Level (dBuV/m)	Margin (dB)	Limit (dBuV/m)	Detector Type
1	4804.332	8.276	38.960	47.237	-26.763	74.000	PEAK
2	* 7205.857	17.857	38.910	56.768	-17.232	74.000	PEAK
3	9608.295	22.463	32.020	54.483	-19.517	74.000	PEAK
4	12011.225	25.360	30.130	55.491	-18.509	74.000	PEAK

Note:

1. All readings above 1GHz are performed with peak and/or average measurements as necessary.
2. Peak measurements: RBW = 1MHz, VBW = 1MHz, Sweep: Auto.
3. Average measurements: RBW = 1MHz, VBW = 10 Hz, Sweep: Auto.
4. “ * ”, means this data is the worst emission level.
5. Measurement Level = Reading Level + Correct Factor.
6. The average measurement was not performed when the peak measured data under the limit of average detection.
7. This Emission test range from 1GHz to 25GHz, but above 13GHz were not included because their levels are too low.

Site : CB4-H	Time : 2017/09/26
Limit : FCC_SpartC_15.209_03M_AV	Margin : 6
Probe : CB4-H_FCC_C_A115_EFS_1-18GHz_1116 - VERTICAL	Power : DC 12V
EUT : Multimedia System	Note : 2DH5_2402MHz

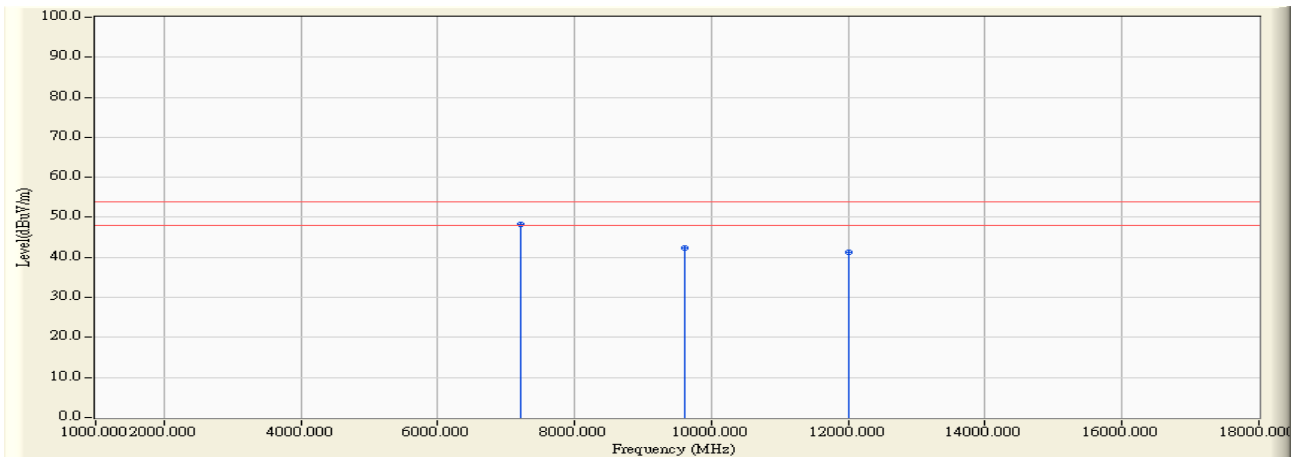

		Frequency (MHz)	Correct Factor (dB)	Reading Level (dBuV)	Measure Level (dBuV/m)	Margin (dB)	Limit (dBuV/m)	Detector Type
1	*	7205.857	17.857	30.280	48.138	-5.862	54.000	AVERAGE
2		9608.295	22.463	19.770	42.233	-11.767	54.000	AVERAGE
3		12011.225	25.360	15.830	41.191	-12.809	54.000	AVERAGE

Note:

1. All readings above 1GHz are performed with peak and/or average measurements as necessary.
2. Peak measurements: RBW = 1MHz, VBW = 1MHz, Sweep: Auto.
3. Average measurements: RBW = 1MHz, VBW = 10 Hz, Sweep: Auto.
4. “ * ”, means this data is the worst emission level.
5. Measurement Level = Reading Level + Correct Factor.
6. The average measurement was not performed when the peak measured data under the limit of average detection.
7. This Emission test range from 1GHz to 25GHz, but above 13GHz were not included because their levels are too low.

Site : CB4-H	Time : 2017/09/26
Limit : FCC_SpartC_15.209_03M_PK	Margin : 6
Probe : CB4-H_FCCCC_A115_EFS_1-18GHz_1116 - HORIZONTAL	Power : DC 12V
EUT : Multimedia System	Note : 2DH5_2441MHz

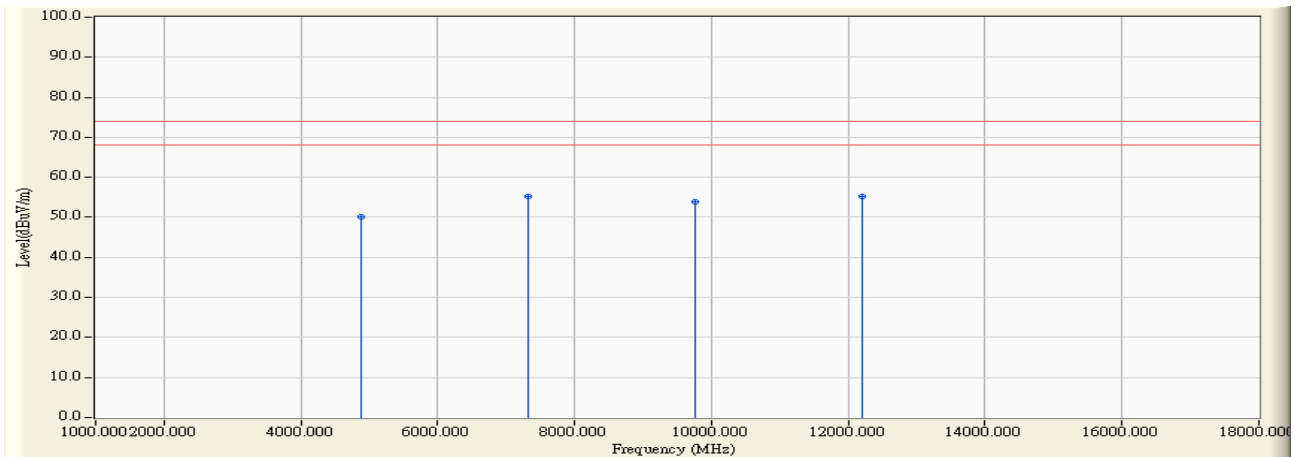

	Frequency (MHz)	Correct Factor (dB)	Reading Level (dBuV)	Measure Level (dBuV/m)	Margin (dB)	Limit (dBuV/m)	Detector Type
1	4881.525	43.280	41.600	50.268	-23.732	74.000	PEAK
2	* 7323.527	50.800	37.170	55.300	-18.700	74.000	PEAK
3	9766.227	23.092	30.810	53.902	-20.098	74.000	PEAK
4	12205.715	25.500	29.790	55.289	-18.711	74.000	PEAK

Note:

1. All readings above 1GHz are performed with peak and/or average measurements as necessary.
2. Peak measurements: RBW = 1MHz, VBW = 1MHz, Sweep: Auto.
3. Average measurements: RBW = 1MHz, VBW = 10 Hz, Sweep: Auto.
4. “ * ”, means this data is the worst emission level.
5. Measurement Level = Reading Level + Correct Factor.
6. The average measurement was not performed when the peak measured data under the limit of average detection.
7. This Emission test range from 1GHz to 25GHz, but above 13GHz were not included because their levels are too low.

Site : CB4-H	Time : 2017/09/26
Limit : FCC_SpartC_15.209_03M_AV	Margin : 6
Probe : CB4-H_FCC_C_A115_EFS_1-18GHz_1116 - HORIZONTAL	Power : DC 12V
EUT : Multimedia System	Note : 2DH5_2441MHz

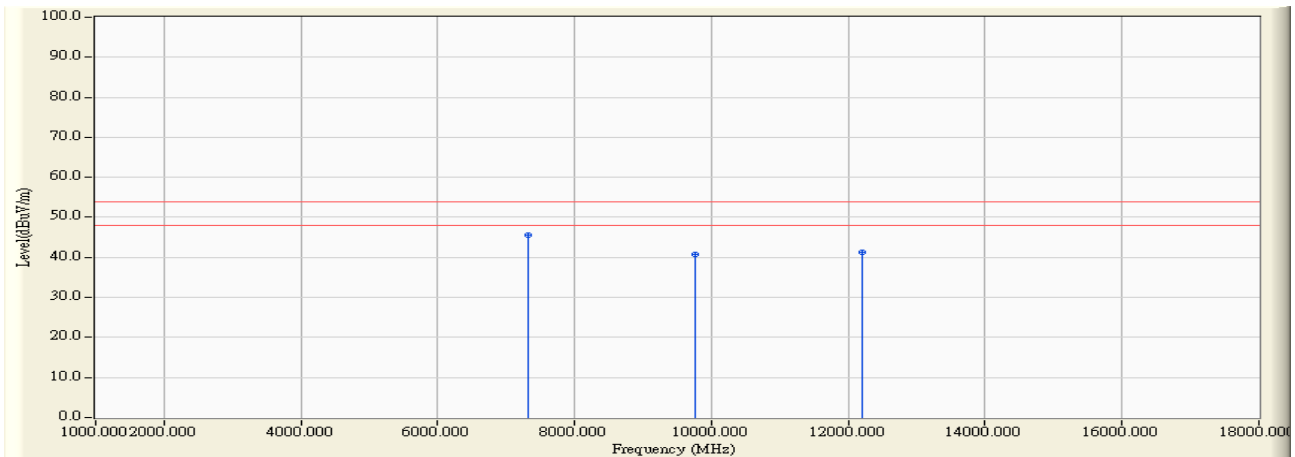

		Frequency (MHz)	Correct Factor (dB)	Reading Level (dBuV)	Measure Level (dBuV/m)	Margin (dB)	Limit (dBuV/m)	Detector Type
1	*	7323.527	18.129	27.380	45.510	-8.490	54.000	AVERAGE
2		9766.227	23.092	17.590	40.682	-13.318	54.000	AVERAGE
3		12205.715	25.500	15.670	41.169	-12.831	54.000	AVERAGE

Note:

1. All readings above 1GHz are performed with peak and/or average measurements as necessary.
2. Peak measurements: RBW = 1MHz, VBW = 1MHz, Sweep: Auto.
3. Average measurements: RBW = 1MHz, VBW = 10 Hz, Sweep: Auto.
4. “ * ”, means this data is the worst emission level.
5. Measurement Level = Reading Level + Correct Factor.
6. The average measurement was not performed when the peak measured data under the limit of average detection.
7. This Emission test range from 1GHz to 25GHz, but above 13GHz were not included because their levels are too low.

Site : CB4-H	Time : 2017/09/26
Limit : FCC_SpartC_15.209_03M_PK	Margin : 6
Probe : CB4-H_FCC_A115_EFS_1-18GHz_1116 - VERTICAL	Power : DC 12V
EUT : Multimedia System	Note : 2DH5_2441MHz

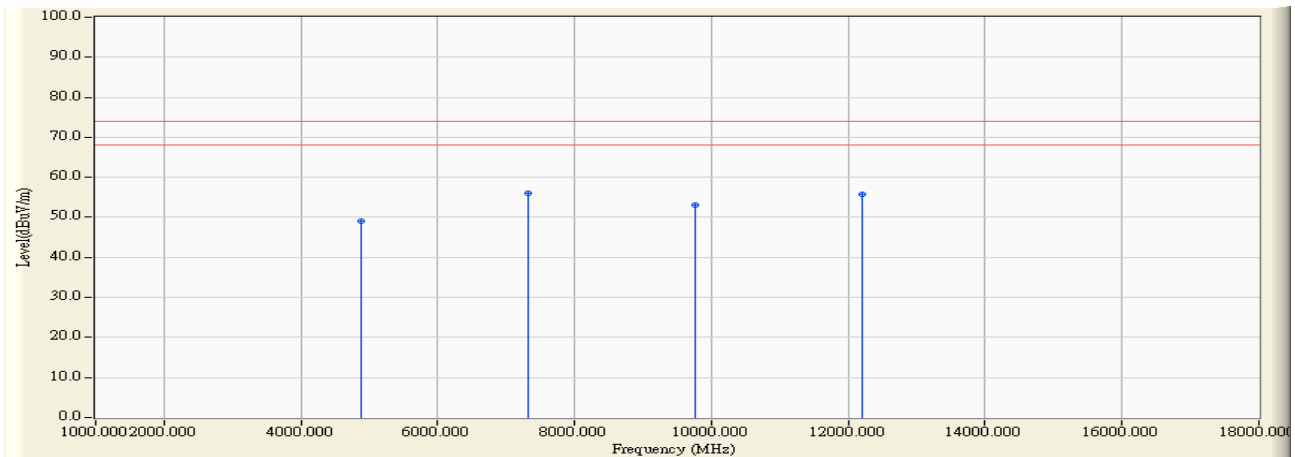

	Frequency (MHz)	Correct Factor (dB)	Reading Level (dBuV)	Measure Level (dBuV/m)	Margin (dB)	Limit (dBuV/m)	Detector Type
1	4881.880	8.670	40.430	49.100	-24.900	74.000	PEAK
2	* 7322.322	18.128	37.980	56.107	-17.893	74.000	PEAK
3	9764.037	23.084	30.020	53.105	-20.895	74.000	PEAK
4	12204.840	25.499	30.200	55.699	-18.301	74.000	PEAK

Note:

1. All readings above 1GHz are performed with peak and/or average measurements as necessary.
2. Peak measurements: RBW = 1MHz, VBW = 1MHz, Sweep: Auto.
3. Average measurements: RBW = 1MHz, VBW = 10 Hz, Sweep: Auto.
4. “ * ”, means this data is the worst emission level.
5. Measurement Level = Reading Level + Correct Factor.
6. The average measurement was not performed when the peak measured data under the limit of average detection.
7. This Emission test range from 1GHz to 25GHz, but above 13GHz were not included because their levels are too low.

Site : CB4-H	Time : 2017/09/26
Limit : FCC_SpartC_15.209_03M_AV	Margin : 6
Probe : CB4-H_FCC_C_A115_EFS_1-18GHz_1116 - VERTICAL	Power : DC 12V
EUT : Multimedia System	Note : 2DH5_2441MHz

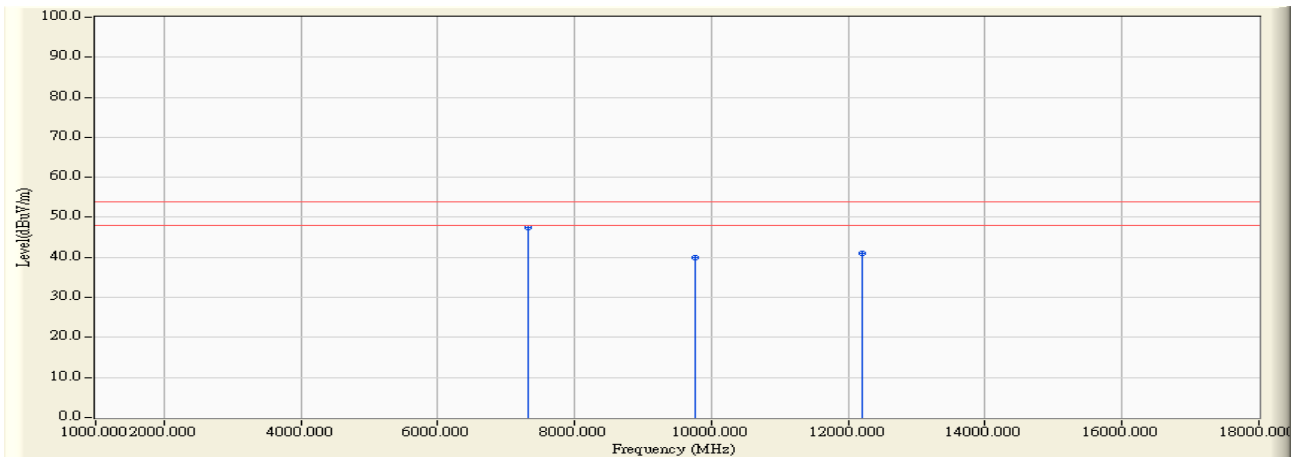

		Frequency (MHz)	Correct Factor (dB)	Reading Level (dBuV)	Measure Level (dBuV/m)	Margin (dB)	Limit (dBuV/m)	Detector Type
1	*	7322.322	18.128	29.290	47.417	-6.583	54.000	AVERAGE
2		9764.037	23.084	16.990	40.075	-13.925	54.000	AVERAGE
3		12204.840	25.499	15.640	41.139	-12.861	54.000	AVERAGE

Note:

1. All readings above 1GHz are performed with peak and/or average measurements as necessary.
2. Peak measurements: RBW = 1MHz, VBW = 1MHz, Sweep: Auto.
3. Average measurements: RBW = 1MHz, VBW = 10 Hz, Sweep: Auto.
4. “ * ”, means this data is the worst emission level.
5. Measurement Level = Reading Level + Correct Factor.
6. The average measurement was not performed when the peak measured data under the limit of average detection.
7. This Emission test range from 1GHz to 25GHz, but above 13GHz were not included because their levels are too low.

Site : CB4-H	Time : 2017/09/26
Limit : FCC_SpartC_15.209_03M_PK	Margin : 6
Probe : CB4-H_FCCCC_A115_EFS_1-18GHz_1116 - HORIZONTAL	Power : DC 12V
EUT : Multimedia System	Note : 2DH5_2480MHz

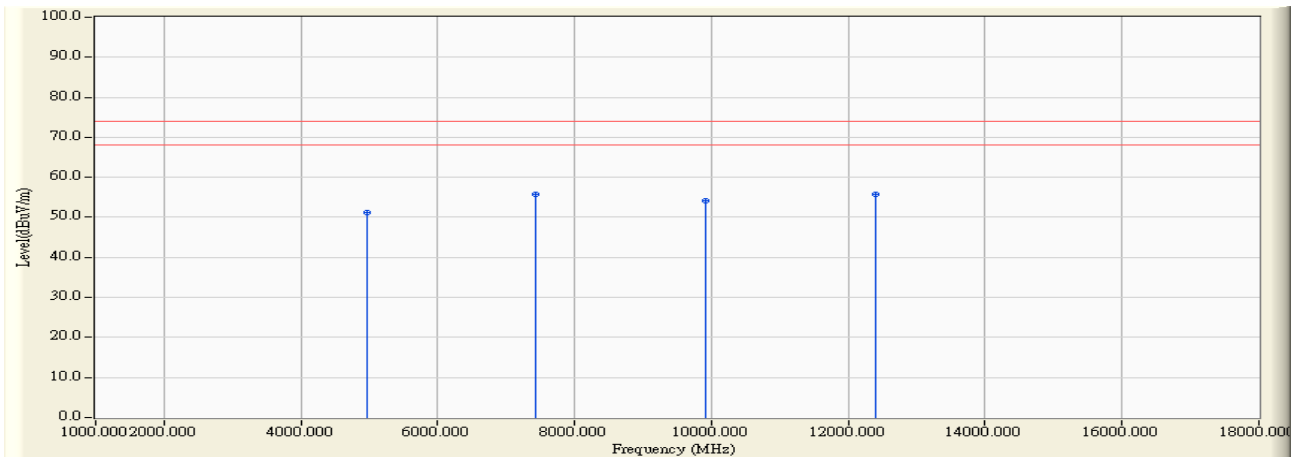

	Frequency (MHz)	Correct Factor (dB)	Reading Level (dBuV)	Measure Level (dBuV/m)	Margin (dB)	Limit (dBuV/m)	Detector Type
1	4960.722	9.070	42.010	51.080	-22.920	74.000	PEAK
2	* 7439.467	18.379	37.470	55.849	-18.151	74.000	PEAK
3	9920.340	23.617	30.410	54.027	-19.973	74.000	PEAK
4	12400.887	25.648	30.170	55.818	-18.182	74.000	PEAK

Note:

1. All readings above 1GHz are performed with peak and/or average measurements as necessary.
2. Peak measurements: RBW = 1MHz, VBW = 1MHz, Sweep: Auto.
3. Average measurements: RBW = 1MHz, VBW = 10 Hz, Sweep: Auto.
4. “ * ”, means this data is the worst emission level.
5. Measurement Level = Reading Level + Correct Factor.
6. The average measurement was not performed when the peak measured data under the limit of average detection.
7. This Emission test range from 1GHz to 25GHz, but above 13GHz were not included because their levels are too low.

Site : CB4-H	Time : 2017/09/26
Limit : FCC_SpartC_15.209_03M_AV	Margin : 6
Probe : CB4-H_FCC_A115_EFS_1-18GHz_1116 - HORIZONTAL	Power : DC 12V
EUT : Multimedia System	Note : 2DH5_2480MHz

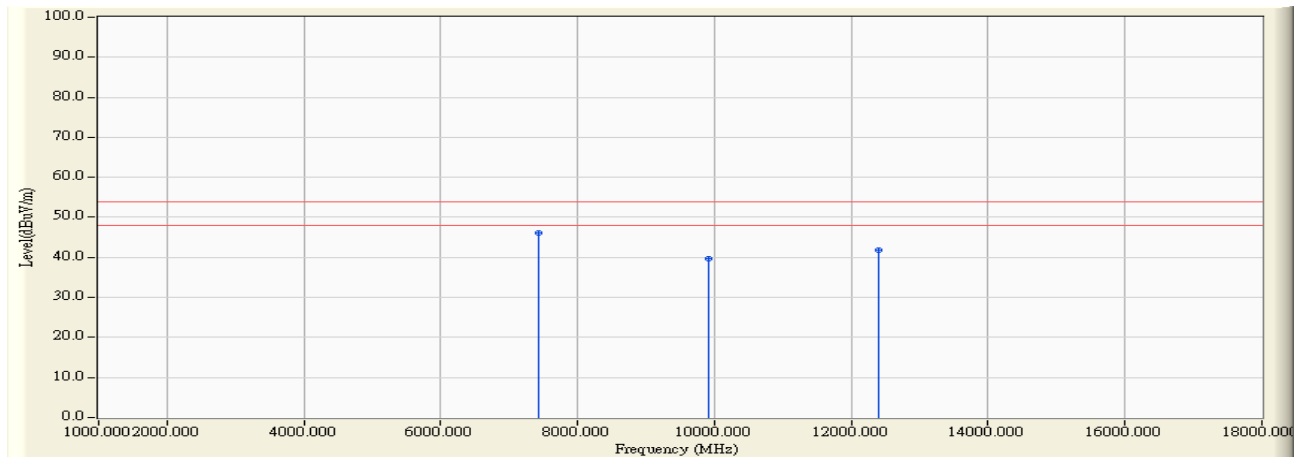

		Frequency (MHz)	Correct Factor (dB)	Reading Level (dBuV)	Measure Level (dBuV/m)	Margin (dB)	Limit (dBuV/m)	Detector Type
1	*	7439.467	18.379	27.820	46.199	-7.801	54.000	AVERAGE
2		9920.340	23.617	16.190	39.807	-14.193	54.000	AVERAGE
3		12400.887	25.648	16.120	41.768	-12.232	54.000	AVERAGE

Note:

1. All readings above 1GHz are performed with peak and/or average measurements as necessary.
2. Peak measurements: RBW = 1MHz, VBW = 1MHz, Sweep: Auto.
3. Average measurements: RBW = 1MHz, VBW = 10 Hz, Sweep: Auto.
4. “ * ”, means this data is the worst emission level.
5. Measurement Level = Reading Level + Correct Factor.
6. The average measurement was not performed when the peak measured data under the limit of average detection.
7. This Emission test range from 1GHz to 25GHz, but above 13GHz were not included because their levels are too low.

Site : CB4-H	Time : 2017/09/26
Limit : FCC_SpartC_15.209_03M_PK	Margin : 6
Probe : CB4-H_FCC_C_A115_EFS_1-18GHz_1116 - VERTICAL	Power : DC 12V
EUT : Multimedia System	Note : 2DH5_2480MHz

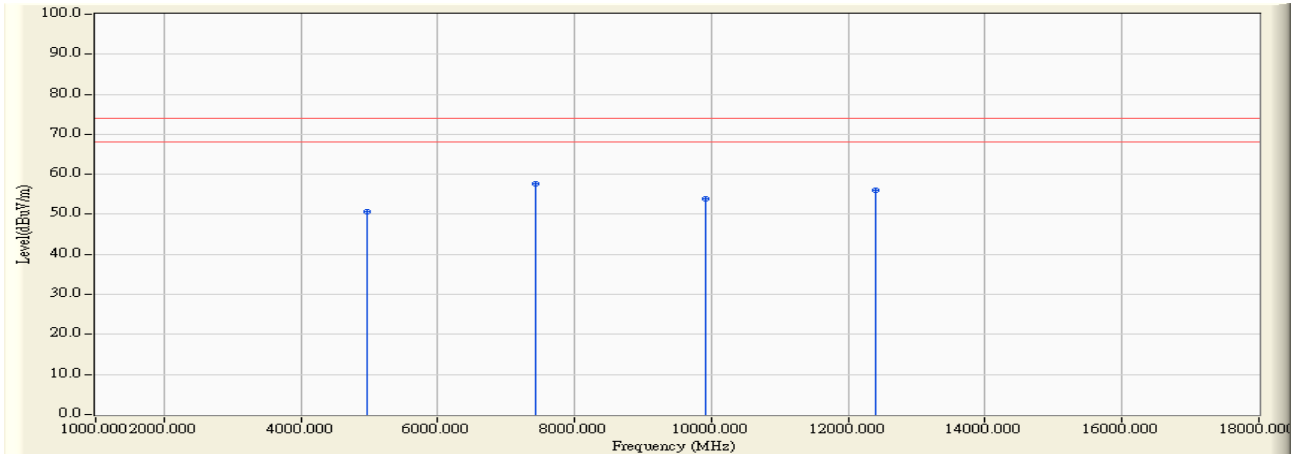

	Frequency (MHz)	Correct Factor (dB)	Reading Level (dBuV)	Measure Level (dBuV/m)	Margin (dB)	Limit (dBuV/m)	Detector Type
1	4960.175	9.068	41.700	50.767	-23.233	74.000	PEAK
2	* 7439.572	18.379	39.150	57.529	-16.471	74.000	PEAK
3	9920.395	23.618	30.300	53.918	-20.082	74.000	PEAK
4	12401.530	25.649	30.490	56.139	-17.861	74.000	PEAK

Note:

1. All readings above 1GHz are performed with peak and/or average measurements as necessary.
2. Peak measurements: RBW = 1MHz, VBW = 1MHz, Sweep: Auto.
3. Average measurements: RBW = 1MHz, VBW = 10 Hz, Sweep: Auto.
4. “ * ”, means this data is the worst emission level.
5. Measurement Level = Reading Level + Correct Factor.
6. The average measurement was not performed when the peak measured data under the limit of average detection.
7. This Emission test range from 1GHz to 25GHz, but above 13GHz were not included because their levels are too low.

Site : CB4-H	Time : 2017/09/26
Limit : FCC_SpartC_15.209_03M_AV	Margin : 6
Probe : CB4-H_FCC_C_A115_EFS_1-18GHz_1116 - VERTICAL	Power : DC 12V
EUT : Multimedia System	Note : 2DH5_2480MHz

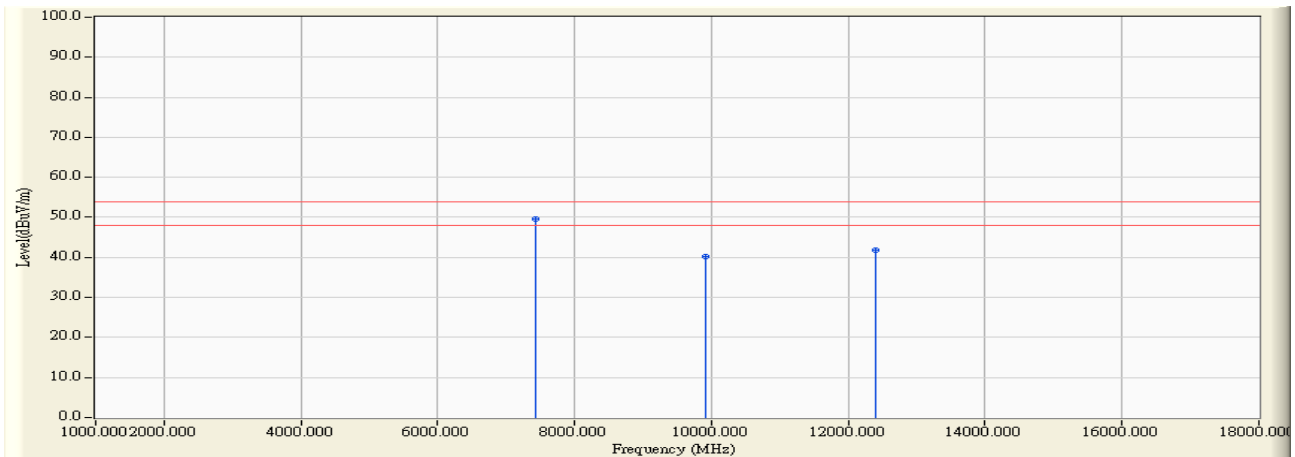

		Frequency (MHz)	Correct Factor (dB)	Reading Level (dBuV)	Measure Level (dBuV/m)	Margin (dB)	Limit (dBuV/m)	Detector Type
1	*	7439.572	18.379	31.220	49.599	-4.401	54.000	AVERAGE
2		9920.395	23.618	16.630	40.248	-13.752	54.000	AVERAGE
3		12401.530	25.649	16.150	41.799	-12.201	54.000	AVERAGE

Note:

1. All readings above 1GHz are performed with peak and/or average measurements as necessary.
2. Peak measurements: RBW = 1MHz, VBW = 1MHz, Sweep: Auto.
3. Average measurements: RBW = 1MHz, VBW = 10 Hz, Sweep: Auto.
4. “ * ”, means this data is the worst emission level.
5. Measurement Level = Reading Level + Correct Factor.
6. The average measurement was not performed when the peak measured data under the limit of average detection.
7. This Emission test range from 1GHz to 25GHz, but above 13GHz were not included because their levels are too low.

Site : CB4-H	Time : 2017/09/26
Limit : FCC_SpartC_15.209_03M_PK	Margin : 6
Probe : CB4-H_FCCCC_A115_EFS_1-18GHz_1116 - HORIZONTAL	Power : DC 12V
EUT : Multimedia System	Note : 3DH5_2402MHz

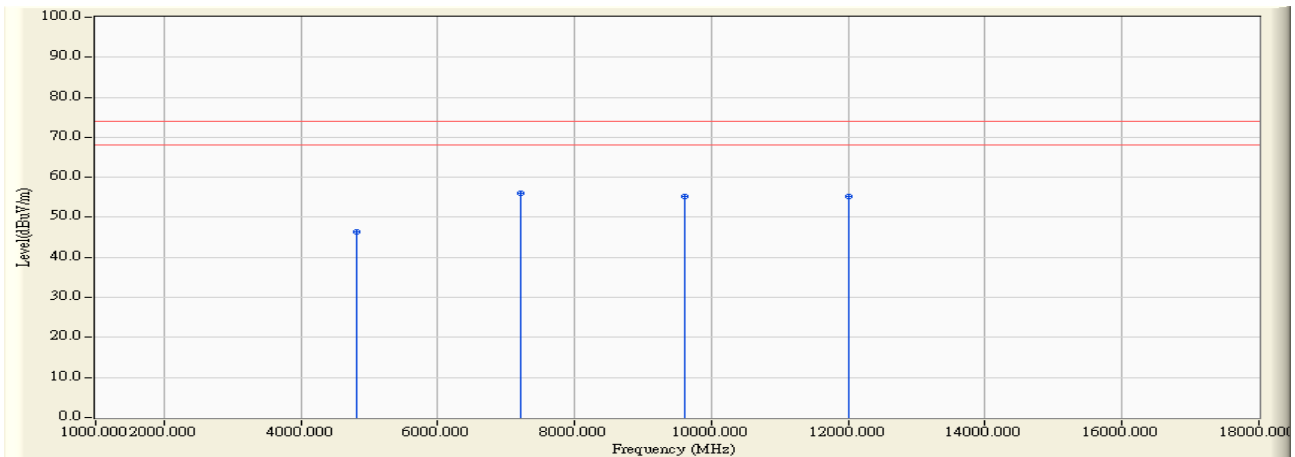

	Frequency (MHz)	Correct Factor (dB)	Reading Level (dBuV)	Measure Level (dBuV/m)	Margin (dB)	Limit (dBuV/m)	Detector Type
1	4803.640	8.273	38.020	46.293	-27.707	74.000	PEAK
2	* 7205.672	17.857	38.110	55.967	-18.033	74.000	PEAK
3	9608.075	22.461	32.820	55.282	-18.718	74.000	PEAK
4	12011.955	25.361	29.890	55.251	-18.749	74.000	PEAK

Note:

1. All readings above 1GHz are performed with peak and/or average measurements as necessary.
2. Peak measurements: RBW = 1MHz, VBW = 1MHz, Sweep: Auto.
3. Average measurements: RBW = 1MHz, VBW = 10 Hz, Sweep: Auto.
4. “ * ”, means this data is the worst emission level.
5. Measurement Level = Reading Level + Correct Factor.
6. The average measurement was not performed when the peak measured data under the limit of average detection.
7. This Emission test range from 1GHz to 25GHz, but above 13GHz were not included because their levels are too low.

Site : CB4-H	Time : 2017/09/26
Limit : FCC_SpartC_15.209_03M_AV	Margin : 6
Probe : CB4-H_FCC_C_A115_EFS_1-18GHz_1116 - HORIZONTAL	Power : DC 12V
EUT : Multimedia System	Note : 3DH5_2402MHz

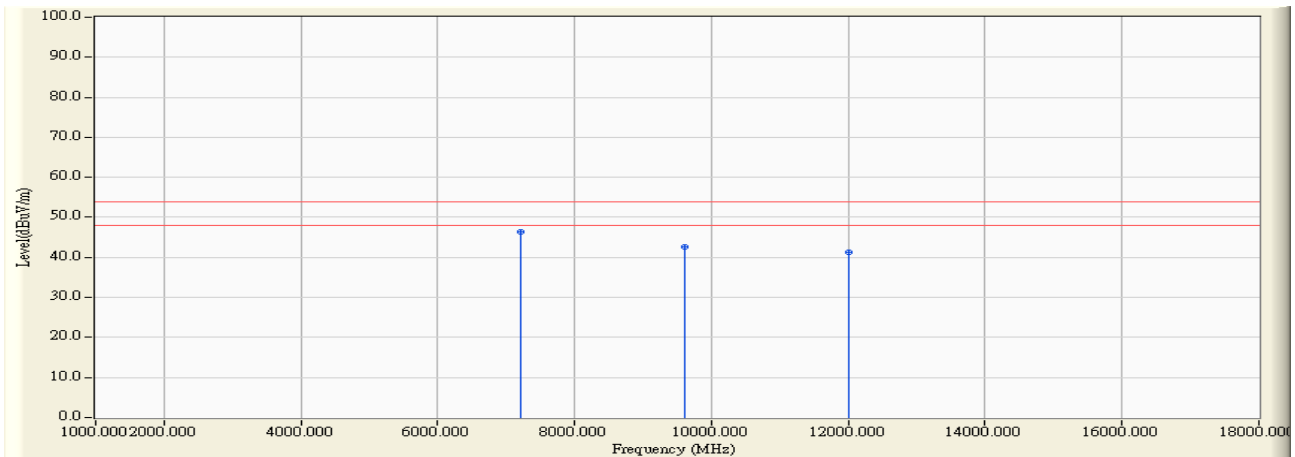

		Frequency (MHz)	Correct Factor (dB)	Reading Level (dBuV)	Measure Level (dBuV/m)	Margin (dB)	Limit (dBuV/m)	Detector Type
1	*	7205.672	17.857	28.580	46.437	-7.563	54.000	AVERAGE
2		9608.075	22.461	20.140	42.602	-11.398	54.000	AVERAGE
3		12011.955	25.361	15.880	41.241	-12.759	54.000	AVERAGE

Note:

1. All readings above 1GHz are performed with peak and/or average measurements as necessary.
2. Peak measurements: RBW = 1MHz, VBW = 1MHz, Sweep: Auto.
3. Average measurements: RBW = 1MHz, VBW = 10 Hz, Sweep: Auto.
4. “ * ”, means this data is the worst emission level.
5. Measurement Level = Reading Level + Correct Factor.
6. The average measurement was not performed when the peak measured data under the limit of average detection.
7. This Emission test range from 1GHz to 25GHz, but above 13GHz were not included because their levels are too low.

Site : CB4-H	Time : 2017/09/26
Limit : FCC_SpartC_15.209_03M_PK	Margin : 6
Probe : CB4-H_FCCCC_A115_EFS_1-18GHz_1116 - VERTICAL	Power : DC 12V
EUT : Multimedia System	Note : 3DH5_2402MHz

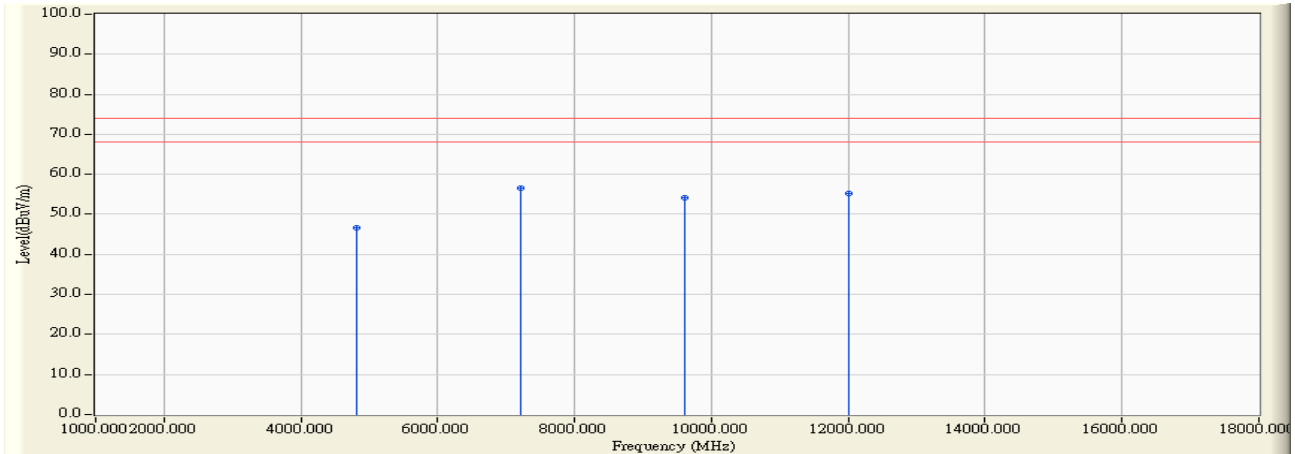

	Frequency (MHz)	Correct Factor (dB)	Reading Level (dBuV)	Measure Level (dBuV/m)	Margin (dB)	Limit (dBuV/m)	Detector Type
1	4803.985	8.275	38.490	46.765	-27.235	74.000	PEAK
2	* 7205.755	17.857	38.720	56.577	-17.423	74.000	PEAK
3	9608.042	22.461	31.770	54.232	-19.768	74.000	PEAK
4	12008.960	25.359	29.980	55.339	-18.661	74.000	PEAK

Note:

1. All readings above 1GHz are performed with peak and/or average measurements as necessary.
2. Peak measurements: RBW = 1MHz, VBW = 1MHz, Sweep: Auto.
3. Average measurements: RBW = 1MHz, VBW = 10 Hz, Sweep: Auto.
4. “ * ”, means this data is the worst emission level.
5. Measurement Level = Reading Level + Correct Factor.
6. The average measurement was not performed when the peak measured data under the limit of average detection.
7. This Emission test range from 1GHz to 25GHz, but above 13GHz were not included because their levels are too low.

Site : CB4-H	Time : 2017/09/26
Limit : FCC_SpartC_15.209_03M_AV	Margin : 6
Probe : CB4-H_FCC_C_A115_EFS_1-18GHz_1116 - VERTICAL	Power : DC 12V
EUT : Multimedia System	Note : 3DH5_2402MHz

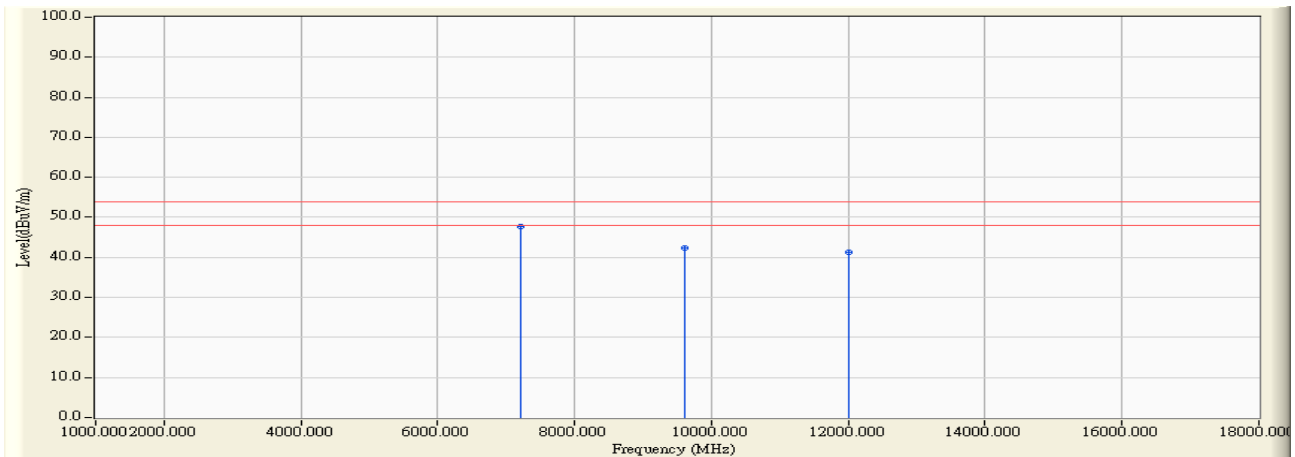

		Frequency (MHz)	Correct Factor (dB)	Reading Level (dBuV)	Measure Level (dBuV/m)	Margin (dB)	Limit (dBuV/m)	Detector Type
1	*	7205.755	17.857	29.750	47.607	-6.393	54.000	AVERAGE
2		9608.042	22.461	19.860	42.322	-11.678	54.000	AVERAGE
3		12008.960	25.359	15.890	41.249	-12.751	54.000	AVERAGE

Note:

1. All readings above 1GHz are performed with peak and/or average measurements as necessary.
2. Peak measurements: RBW = 1MHz, VBW = 1MHz, Sweep: Auto.
3. Average measurements: RBW = 1MHz, VBW = 10 Hz, Sweep: Auto.
4. “ * ”, means this data is the worst emission level.
5. Measurement Level = Reading Level + Correct Factor.
6. The average measurement was not performed when the peak measured data under the limit of average detection.
7. This Emission test range from 1GHz to 25GHz, but above 13GHz were not included because their levels are too low.

Site : CB4-H	Time : 2017/09/26
Limit : FCC_SpartC_15.209_03M_PK	Margin : 6
Probe : CB4-H_FCCCC_A115_EFS_1-18GHz_1116 - HORIZONTAL	Power : DC 12V
EUT : Multimedia System	Note : 3DH5_2441MHz

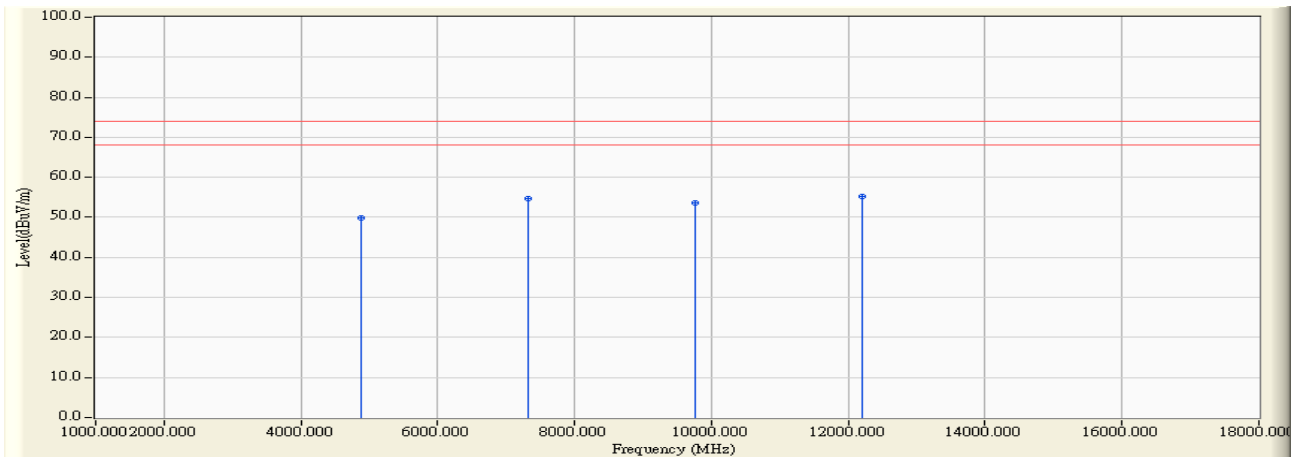

	Frequency (MHz)	Correct Factor (dB)	Reading Level (dBuV)	Measure Level (dBuV/m)	Margin (dB)	Limit (dBuV/m)	Detector Type
1	4881.702	8.669	41.120	49.789	-24.211	74.000	PEAK
2	7323.280	18.129	36.580	54.710	-19.290	74.000	PEAK
3	9764.490	23.087	30.500	53.586	-20.414	74.000	PEAK
4	* 12203.992	25.498	29.730	55.228	-18.772	74.000	PEAK

Note:

1. All readings above 1GHz are performed with peak and/or average measurements as necessary.
2. Peak measurements: RBW = 1MHz, VBW = 1MHz, Sweep: Auto.
3. Average measurements: RBW = 1MHz, VBW = 10 Hz, Sweep: Auto.
4. “ * ”, means this data is the worst emission level.
5. Measurement Level = Reading Level + Correct Factor.
6. The average measurement was not performed when the peak measured data under the limit of average detection.
7. This Emission test range from 1GHz to 25GHz, but above 13GHz were not included because their levels are too low.

Site : CB4-H	Time : 2017/09/26
Limit : FCC_SpartC_15.209_03M_AV	Margin : 6
Probe : CB4-H_FCC_C_A115_EFS_1-18GHz_1116 - HORIZONTAL	Power : DC 12V
EUT : Multimedia System	Note : 3DH5_2441MHz

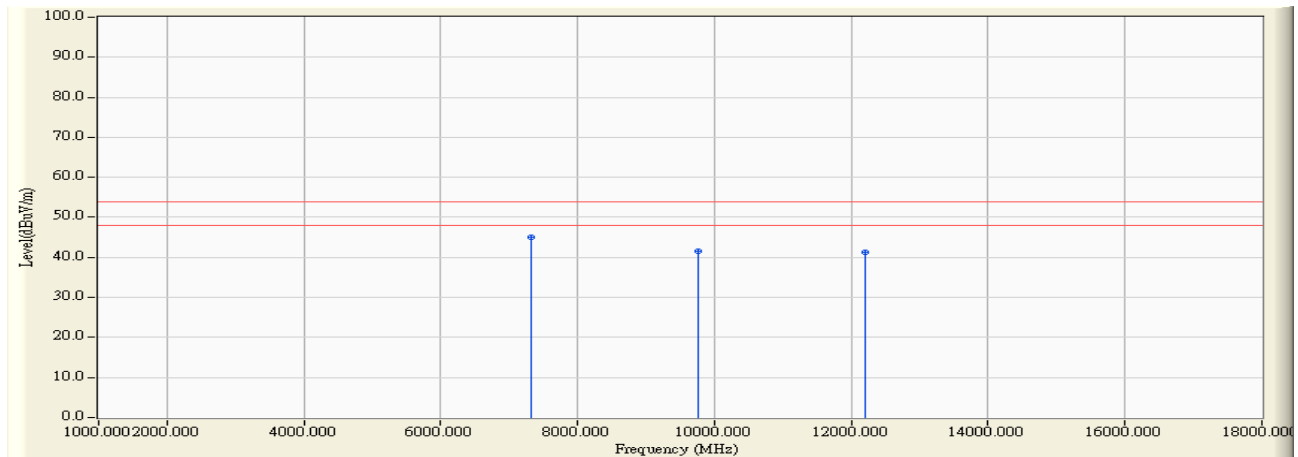

		Frequency (MHz)	Correct Factor (dB)	Reading Level (dBuV)	Measure Level (dBuV/m)	Margin (dB)	Limit (dBuV/m)	Detector Type
1	*	7323.280	18.129	26.830	44.960	-9.040	54.000	AVERAGE
2		9764.490	23.087	18.340	41.426	-12.574	54.000	AVERAGE
3		12203.992	25.498	15.710	41.208	-12.792	54.000	AVERAGE

Note:

1. All readings above 1GHz are performed with peak and/or average measurements as necessary.
2. Peak measurements: RBW = 1MHz, VBW = 1MHz, Sweep: Auto.
3. Average measurements: RBW = 1MHz, VBW = 10 Hz, Sweep: Auto.
4. “ * ”, means this data is the worst emission level.
5. Measurement Level = Reading Level + Correct Factor.
6. The average measurement was not performed when the peak measured data under the limit of average detection.
7. This Emission test range from 1GHz to 25GHz, but above 13GHz were not included because their levels are too low.

Site : CB4-H	Time : 2017/09/26
Limit : FCC_SpartC_15.209_03M_PK	Margin : 6
Probe : CB4-H_FCCCC_A115_EFS_1-18GHz_1116 - VERTICAL	Power : DC 12V
EUT : Multimedia System	Note : 3DH5_2441MHz

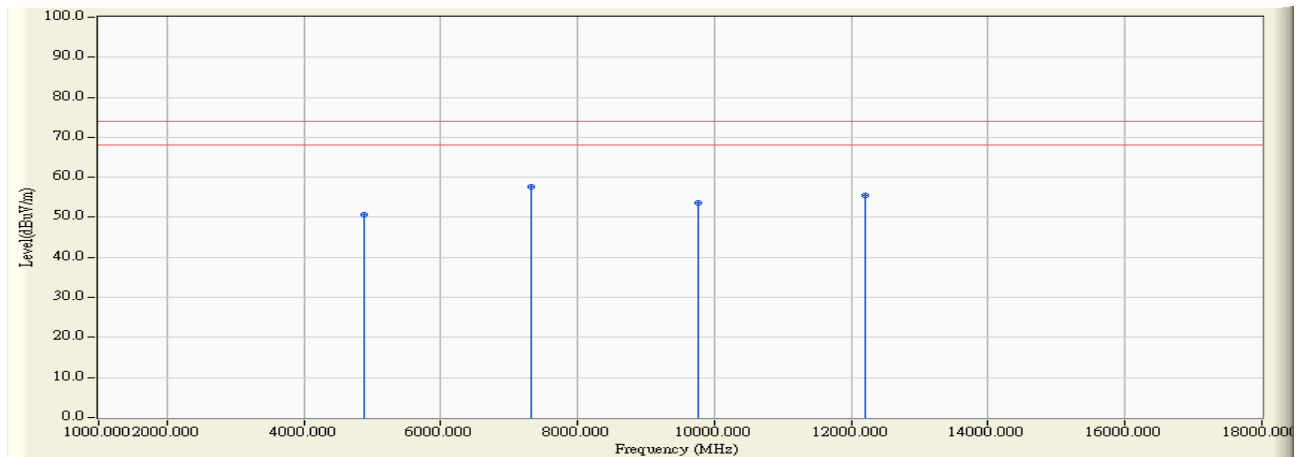

	Frequency (MHz)	Correct Factor (dB)	Reading Level (dBuV)	Measure Level (dBuV/m)	Margin (dB)	Limit (dBuV/m)	Detector Type
1	4881.960	8.670	41.920	50.591	-23.409	74.000	PEAK
2	* 7322.685	18.128	39.590	57.718	-16.282	74.000	PEAK
3	9765.097	23.088	30.650	53.738	-20.262	74.000	PEAK
4	12205.750	25.500	30.000	55.499	-18.501	74.000	PEAK

Note:

1. All readings above 1GHz are performed with peak and/or average measurements as necessary.
2. Peak measurements: RBW = 1MHz, VBW = 1MHz, Sweep: Auto.
3. Average measurements: RBW = 1MHz, VBW = 10 Hz, Sweep: Auto.
4. “ * ”, means this data is the worst emission level.
5. Measurement Level = Reading Level + Correct Factor.
6. The average measurement was not performed when the peak measured data under the limit of average detection.
7. This Emission test range from 1GHz to 25GHz, but above 13GHz were not included because their levels are too low.

Site : CB4-H	Time : 2017/09/26
Limit : FCC_SpartC_15.209_03M_AV	Margin : 6
Probe : CB4-H_FCC_C_A115_EFS_1-18GHz_1116 - VERTICAL	Power : DC 12V
EUT : Multimedia System	Note : 3DH5_2441MHz

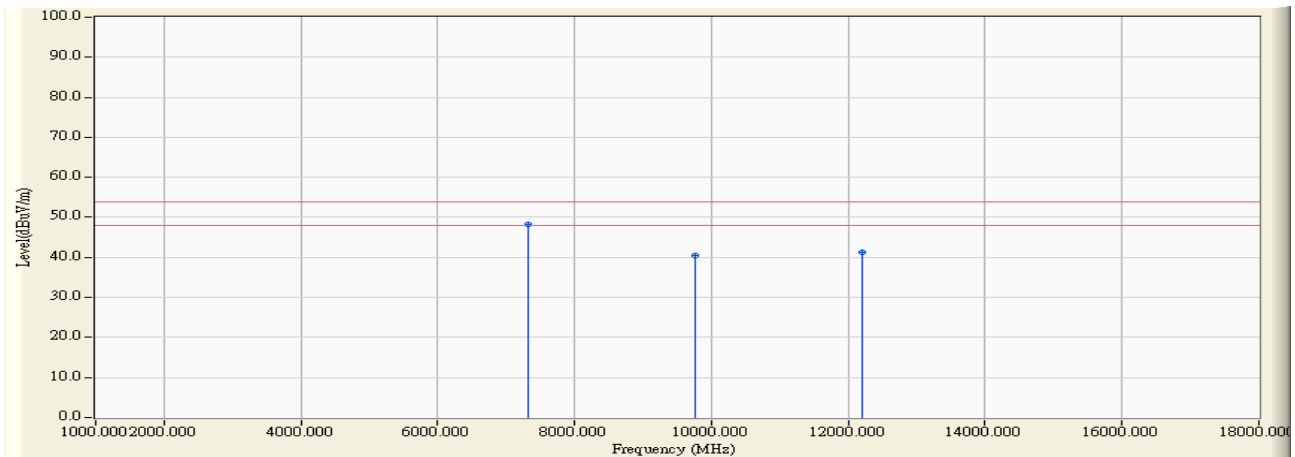

		Frequency (MHz)	Correct Factor (dB)	Reading Level (dBuV)	Measure Level (dBuV/m)	Margin (dB)	Limit (dBuV/m)	Detector Type
1	*	7322.685	18.128	30.190	48.318	-5.682	54.000	AVERAGE
2		9765.097	23.088	17.500	40.588	-13.412	54.000	AVERAGE
3		12205.750	25.500	15.660	41.159	-12.841	54.000	AVERAGE

Note:

1. All readings above 1GHz are performed with peak and/or average measurements as necessary.
2. Peak measurements: RBW = 1MHz, VBW = 1MHz, Sweep: Auto.
3. Average measurements: RBW = 1MHz, VBW = 10 Hz, Sweep: Auto.
4. “ * ”, means this data is the worst emission level.
5. Measurement Level = Reading Level + Correct Factor.
6. The average measurement was not performed when the peak measured data under the limit of average detection.
7. This Emission test range from 1GHz to 25GHz, but above 13GHz were not included because their levels are too low.

Site : CB4-H	Time : 2017/09/26
Limit : FCC_SpartC_15.209_03M_PK	Margin : 6
Probe : CB4-H_FCCCC_A115_EFS_1-18GHz_1116 - HORIZONTAL	Power : DC 12V
EUT : Multimedia System	Note : 3DH5_2480MHz

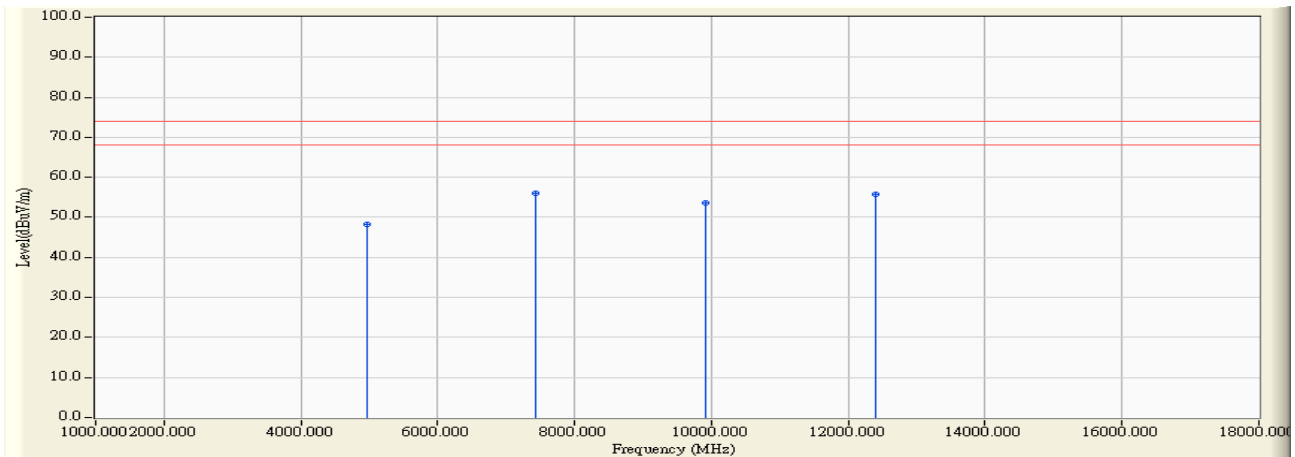

	Frequency (MHz)	Correct Factor (dB)	Reading Level (dBuV)	Measure Level (dBuV/m)	Margin (dB)	Limit (dBuV/m)	Detector Type
1	4960.515	9.069	39.120	48.189	-25.811	74.000	PEAK
2	* 7439.622	18.380	37.610	55.989	-18.011	74.000	PEAK
3	9919.777	23.616	29.900	53.516	-20.484	74.000	PEAK
4	12401.487	25.649	30.100	55.749	-18.251	74.000	PEAK

Note:

1. All readings above 1GHz are performed with peak and/or average measurements as necessary.
2. Peak measurements: RBW = 1MHz, VBW = 1MHz, Sweep: Auto.
3. Average measurements: RBW = 1MHz, VBW = 10 Hz, Sweep: Auto.
4. “ * ”, means this data is the worst emission level.
5. Measurement Level = Reading Level + Correct Factor.
6. The average measurement was not performed when the peak measured data under the limit of average detection.
7. This Emission test range from 1GHz to 25GHz, but above 13GHz were not included because their levels are too low.

Site : CB4-H	Time : 2017/09/26
Limit : FCC_SpartC_15.209_03M_AV	Margin : 6
Probe : CB4-H_FCCFC_A115_EFS_1-18GHz_1116 - HORIZONTAL	Power : DC 12V
EUT : Multimedia System	Note : 3DH5_2480MHz

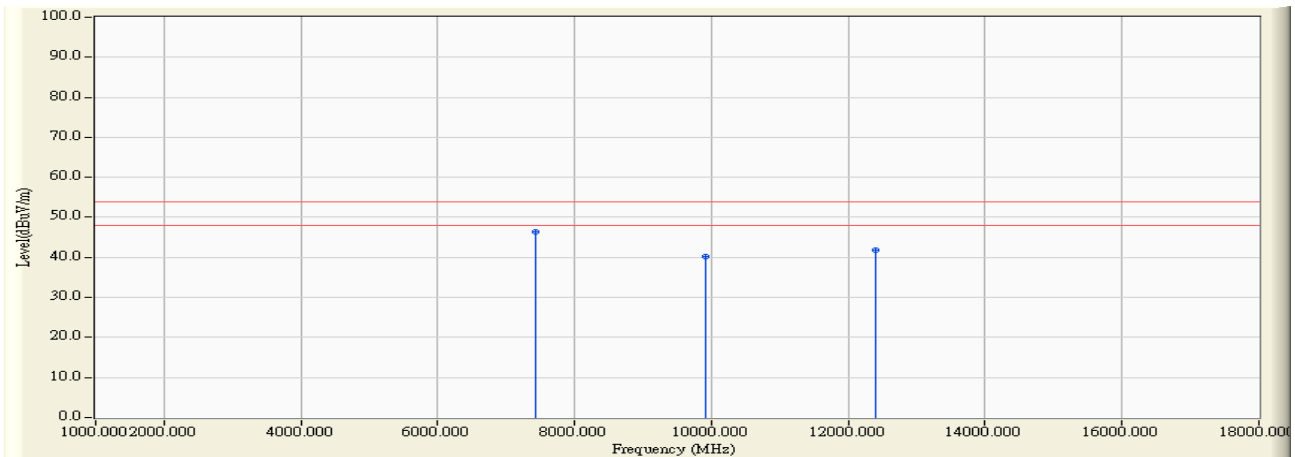

		Frequency (MHz)	Correct Factor (dB)	Reading Level (dBuV)	Measure Level (dBuV/m)	Margin (dB)	Limit (dBuV/m)	Detector Type
1	*	7439.622	18.380	27.950	46.329	-7.671	54.000	AVERAGE
2		9919.777	23.616	16.690	40.306	-13.694	54.000	AVERAGE
3		12401.487	25.649	16.150	41.799	-12.201	54.000	AVERAGE

Note:

1. All readings above 1GHz are performed with peak and/or average measurements as necessary.
2. Peak measurements: RBW = 1MHz, VBW = 1MHz, Sweep: Auto.
3. Average measurements: RBW = 1MHz, VBW = 10 Hz, Sweep: Auto.
4. “ * ”, means this data is the worst emission level.
5. Measurement Level = Reading Level + Correct Factor.
6. The average measurement was not performed when the peak measured data under the limit of average detection.
7. This Emission test range from 1GHz to 25GHz, but above 13GHz were not included because their levels are too low.

Site : CB4-H	Time : 2017/09/26
Limit : FCC_SpartC_15.209_03M_PK	Margin : 6
Probe : CB4-H_FCCFC_A115_EFS_1-18GHz_1116 - VERTICAL	Power : DC 12V
EUT : Multimedia System	Note : 3DH5_2480MHz

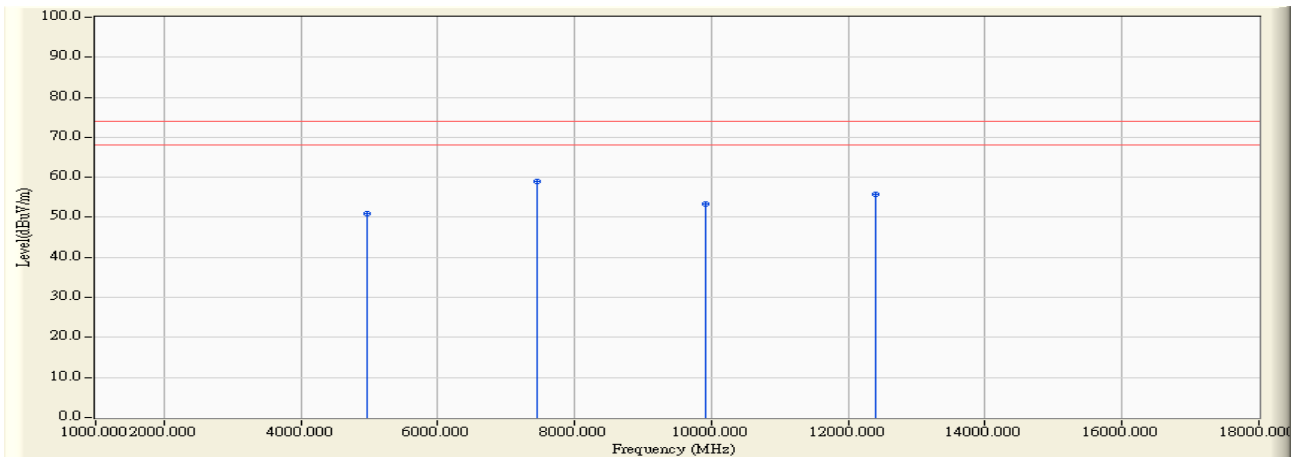

	Frequency (MHz)	Correct Factor (dB)	Reading Level (dBuV)	Measure Level (dBuV/m)	Margin (dB)	Limit (dBuV/m)	Detector Type
1	4959.807	9.065	41.740	50.806	-23.194	74.000	PEAK
2	* 7440.687	18.381	40.580	58.961	-15.039	74.000	PEAK
3	9919.632	23.615	29.740	53.355	-20.645	74.000	PEAK
4	12397.587	25.645	30.110	55.756	-18.244	74.000	PEAK

Note:

1. All readings above 1GHz are performed with peak and/or average measurements as necessary.
2. Peak measurements: RBW = 1MHz, VBW = 1MHz, Sweep: Auto.
3. Average measurements: RBW = 1MHz, VBW = 10 Hz, Sweep: Auto.
4. “ * ”, means this data is the worst emission level.
5. Measurement Level = Reading Level + Correct Factor.
6. The average measurement was not performed when the peak measured data under the limit of average detection.
7. This Emission test range from 1GHz to 25GHz, but above 13GHz were not included because their levels are too low.

Site : CB4-H	Time : 2017/09/26
Limit : FCC_SpartC_15.209_03M_AV	Margin : 6
Probe : CB4-H_FCC_C_A115_EFS_1-18GHz_1116 - VERTICAL	Power : DC 12V
EUT : Multimedia System	Note : 3DH5_2480MHz

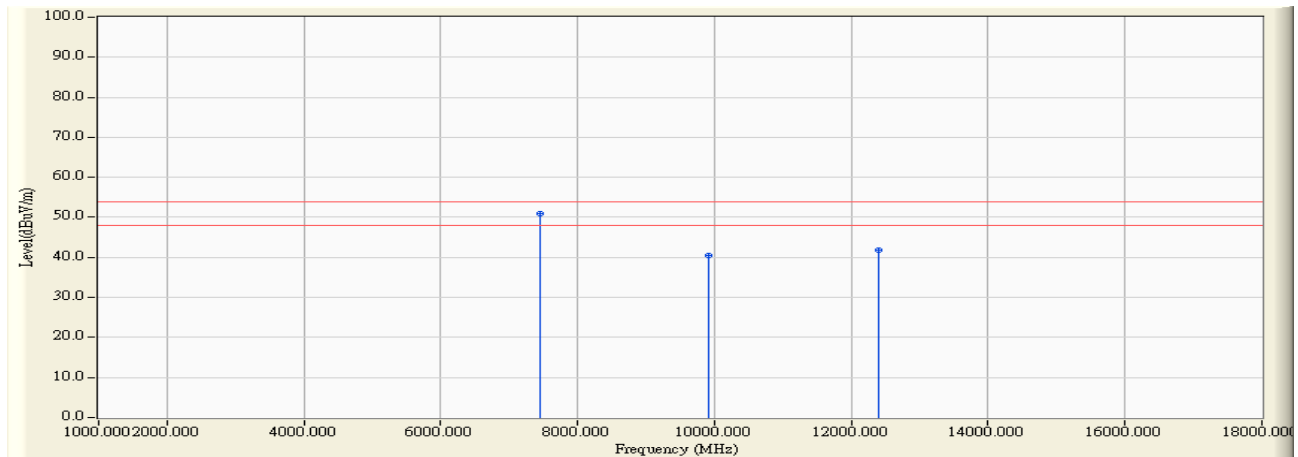

		Frequency (MHz)	Correct Factor (dB)	Reading Level (dBuV)	Measure Level (dBuV/m)	Margin (dB)	Limit (dBuV/m)	Detector Type
1	*	7440.687	18.381	32.480	50.861	-3.139	54.000	AVERAGE
2		9919.632	23.615	16.840	40.455	-13.545	54.000	AVERAGE
3		12397.587	25.645	16.140	41.786	-12.214	54.000	AVERAGE

Note:

1. All readings above 1GHz are performed with peak and/or average measurements as necessary.
2. Peak measurements: RBW = 1MHz, VBW = 1MHz, Sweep: Auto.
3. Average measurements: RBW = 1MHz, VBW = 10 Hz, Sweep: Auto.
4. “ * ”, means this data is the worst emission level.
5. Measurement Level = Reading Level + Correct Factor.
6. The average measurement was not performed when the peak measured data under the limit of average detection.
7. This Emission test range from 1GHz to 25GHz, but above 13GHz were not included because their levels are too low.

5. RF antenna conducted test

5.1. Test Equipment

The following test equipment is used during the test:

RF antenna conducted test / SR10-H

Instrument	Manufacturer	Model No.	Serial No	Next Cal. Date
Signal & Spectrum Analyzer	R&S	FSV40	101049	2017/01/23
EXA Signal Analyzer	Keysight	N9010A	MY51440132	2017/03/13
Spectrum Analyzer	Agilent	N9010A	US47140172	2017/07/26

Note: All equipment that need to calibrate are with calibration period of 1 year.

5.2. Test Setup

RF Conducted Measurement:

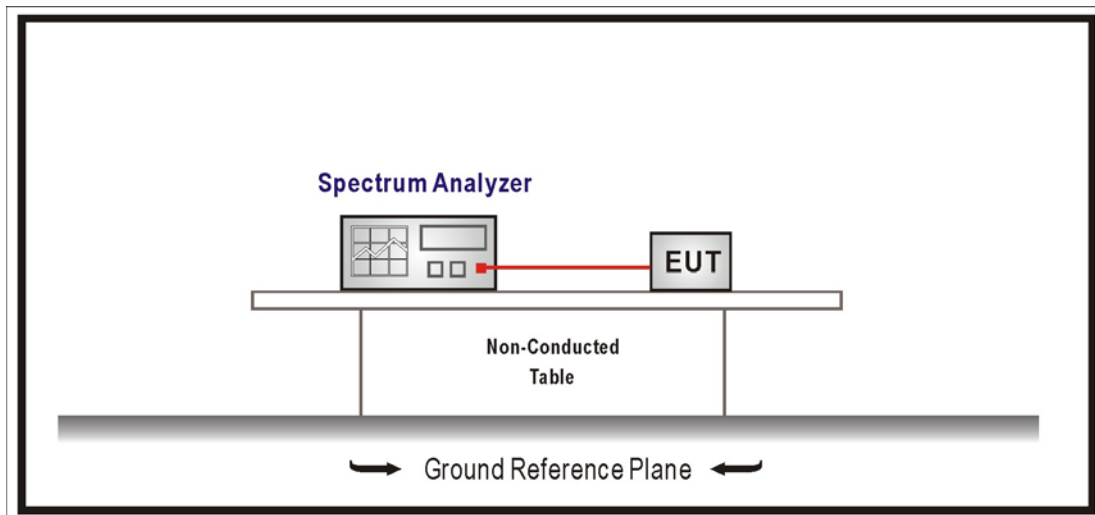

5.3. Limits

In any 100 kHz bandwidth outside the frequency band in which the spread spectrum intentional radiator is operating, the radio frequency power that is produced by the intentional radiator shall be at least 20 dB below that in the 100 kHz bandwidth within the band that contains the highest level of the desired power, based on an RF conducted or radiated measurement. Attenuation below the general limits specified in Section 15.209(a) is not required. In addition, radiated emissions which fall in the restricted bands, as defined in Section 15.205(a), must also comply with the radiated emission limits specified in Section 15.209(a) (see Section 15.205(c)).

5.4. Test Procedure

The EUT was setup according to ANSI C63.10:2013 and tested according to FHSS test procedure of FCC Public Notice DA 00-705 for compliance to FCC 47CFR 15.247 requirements

Set RBW = 100 kHz, Set VBW > RBW, scan up through 10th harmonic.

5.5. Test Specification

According to FCC Part 15 Subpart C Paragraph 15.247: 2015

5.6. Test Result

Product	Multimedia System		
Test Item	RF antenna conducted test		
Test Mode	Mode 1: Transmit		
Date of Test	2017/09/27	Test Site	SR10-H

GFSK

Channel	Frequency (MHz)	Measure Level (dBc)	Limit (dBc)	Result
00	2402	45.828	≥ 20	Pass
39	2441	59.649	≥ 20	Pass
78	2480	56.016	≥ 20	Pass

Channel 00

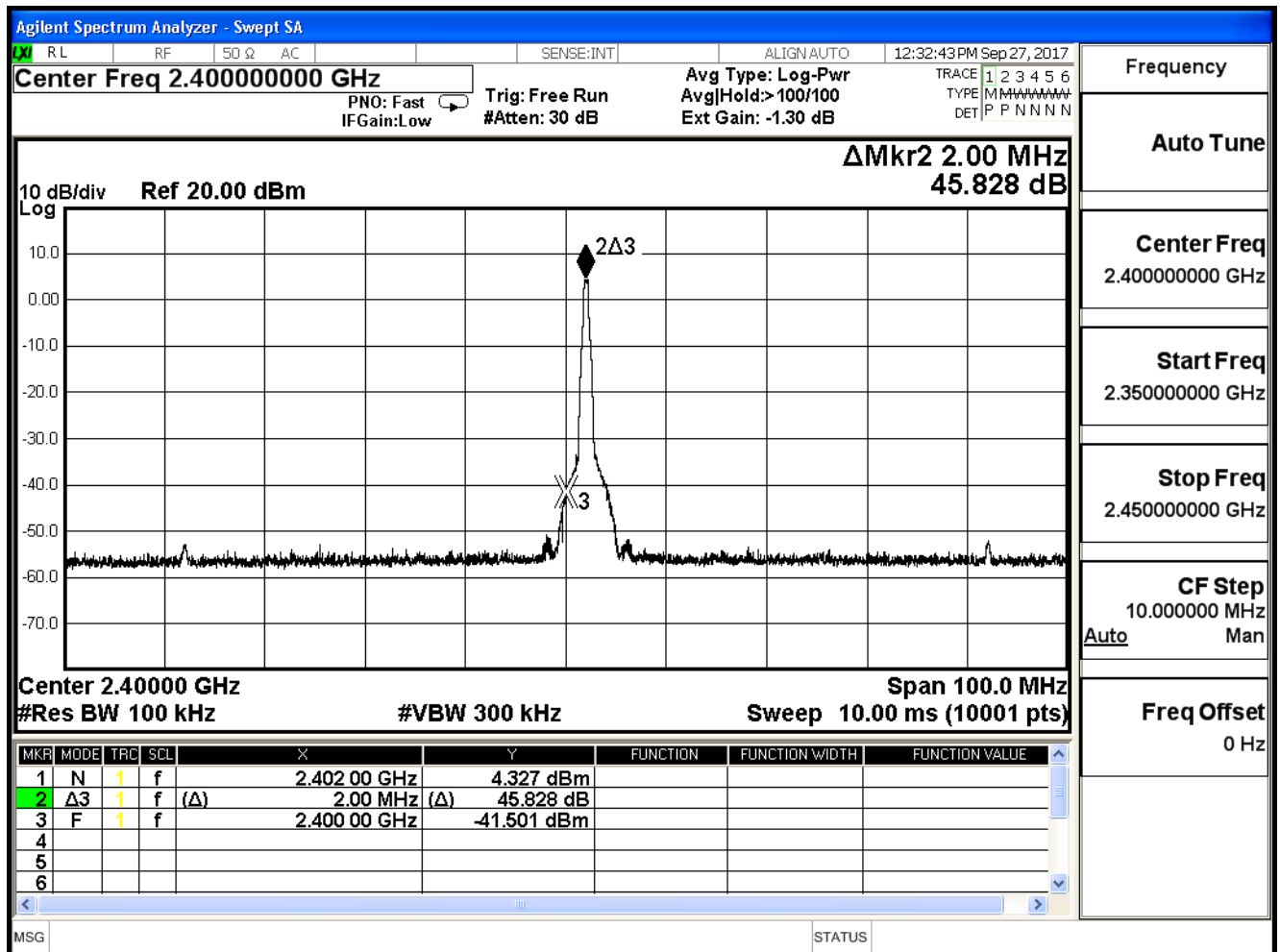

Channel 39

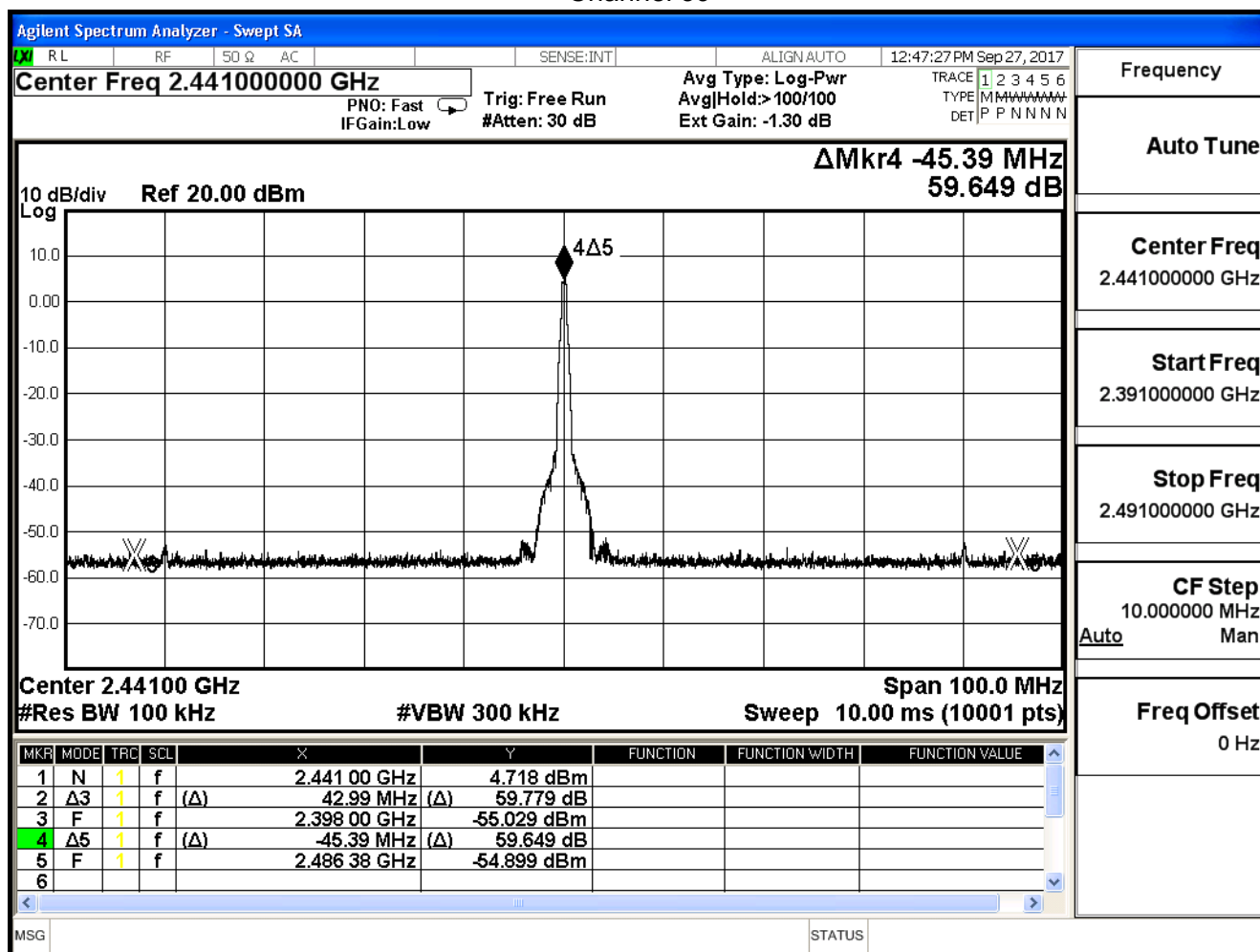

Channel 78

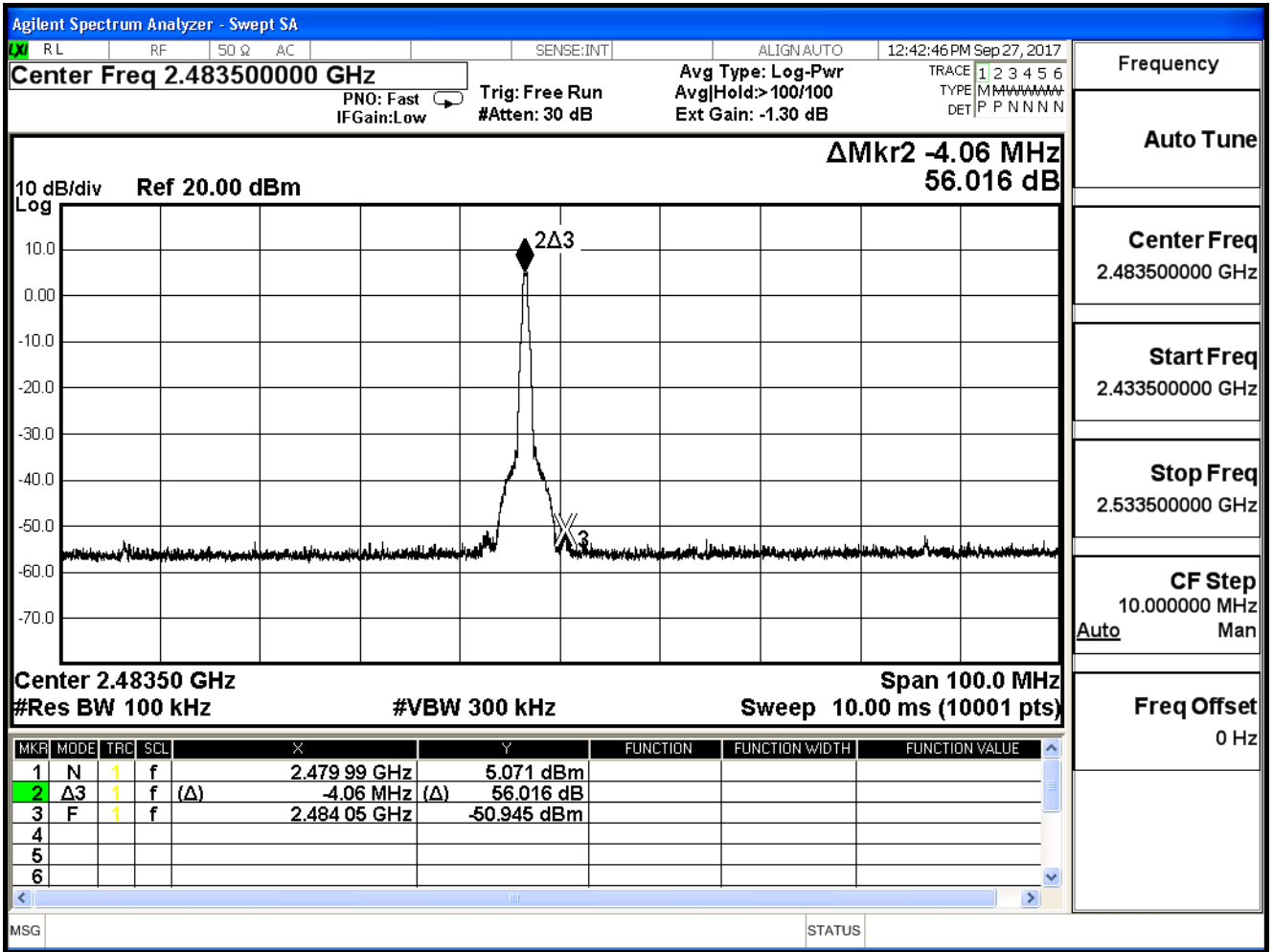

Product	Multimedia System		
Test Item	RF antenna conducted test		
Test Mode	Mode 1: Transmit		
Date of Test	2017/09/27	Test Site	SR10-H

$\pi/4$ -DQPSK

Channel	Frequency (MHz)	Measure Level (dBc)	Limit (dBc)	Result
00	2402	28.404	≥ 20	Pass
39	2441	59.801	≥ 20	Pass
78	2480	37.985	≥ 20	Pass

Channel 00

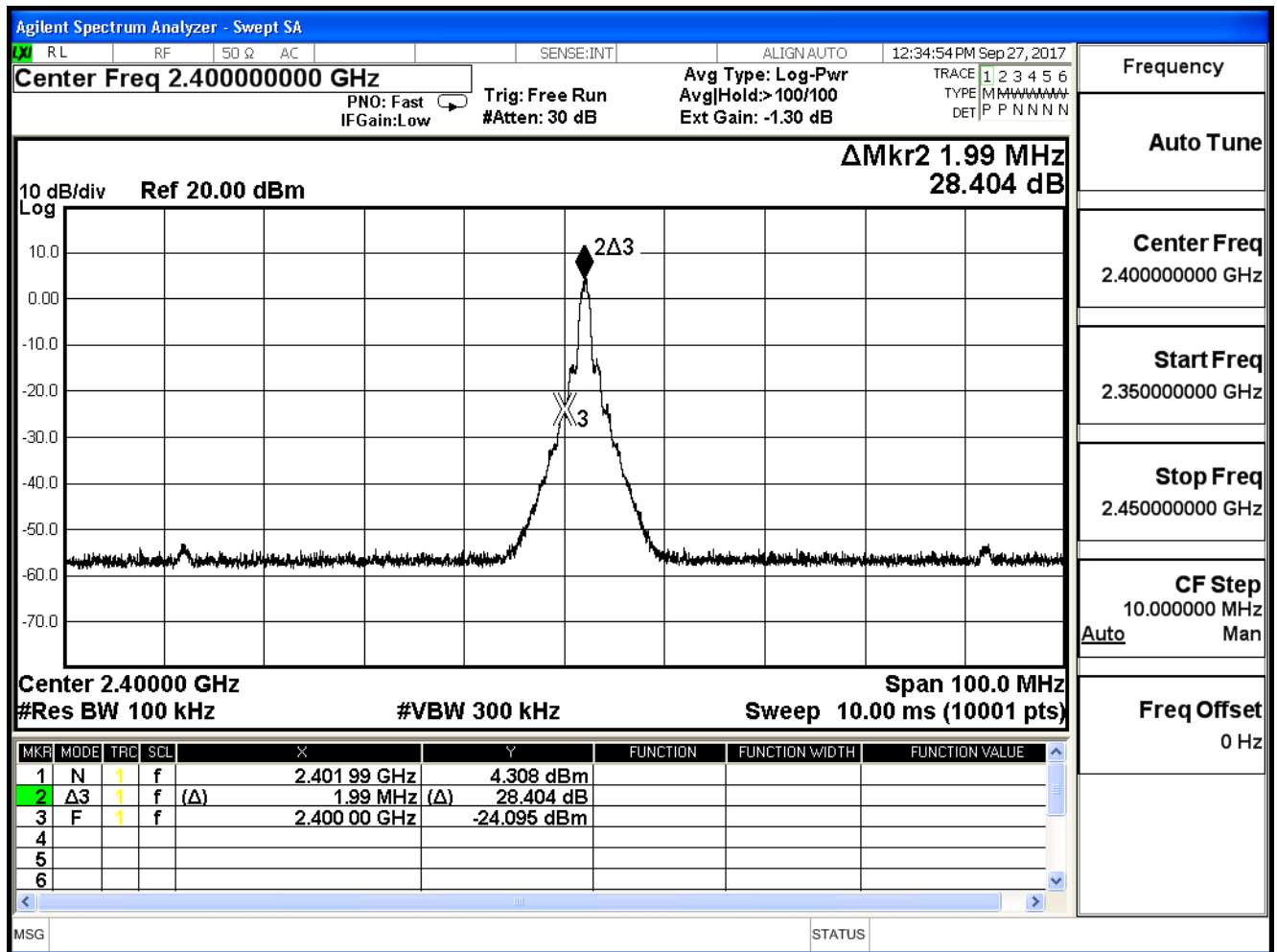

Channel 39

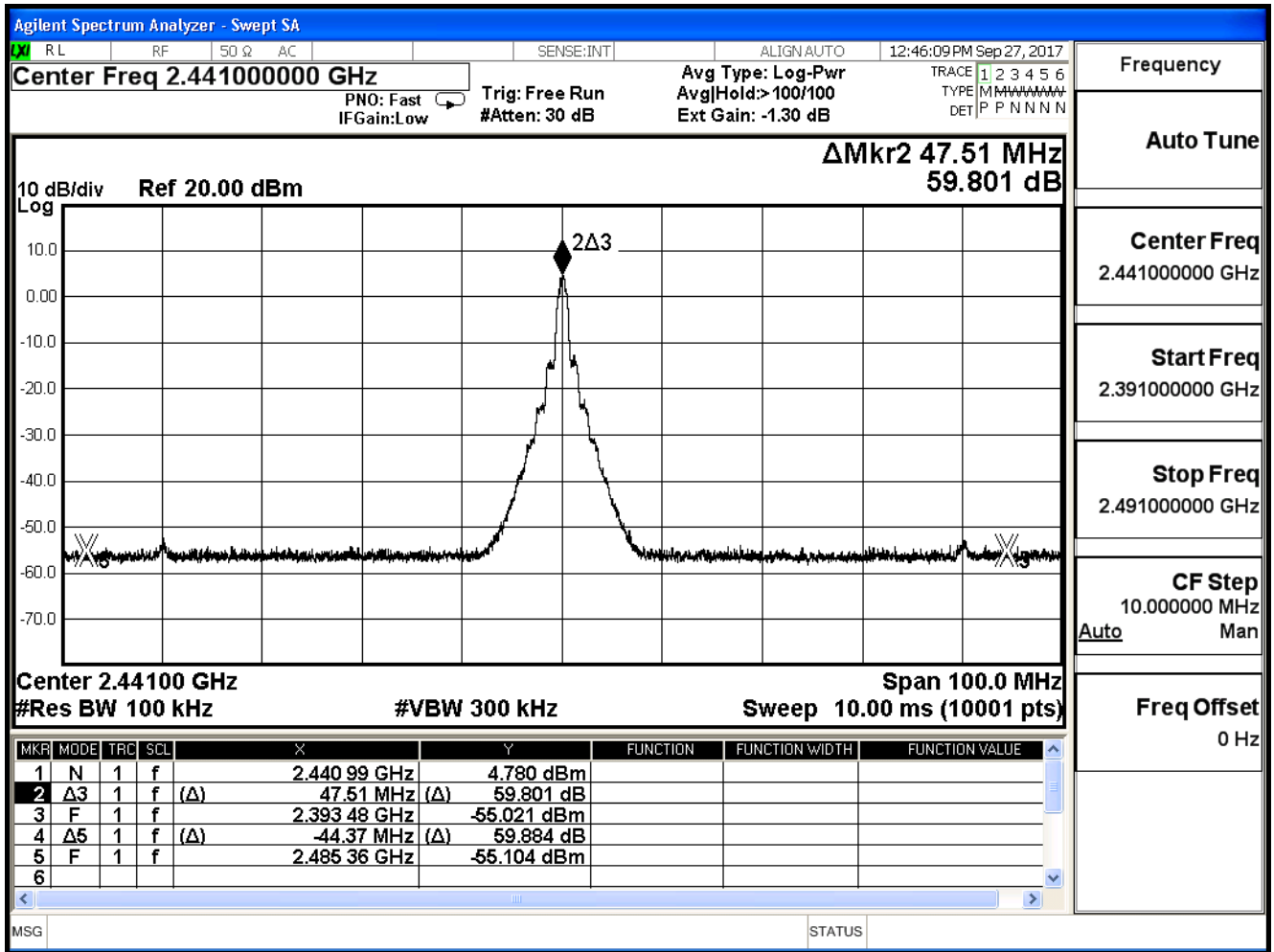

Channel 78

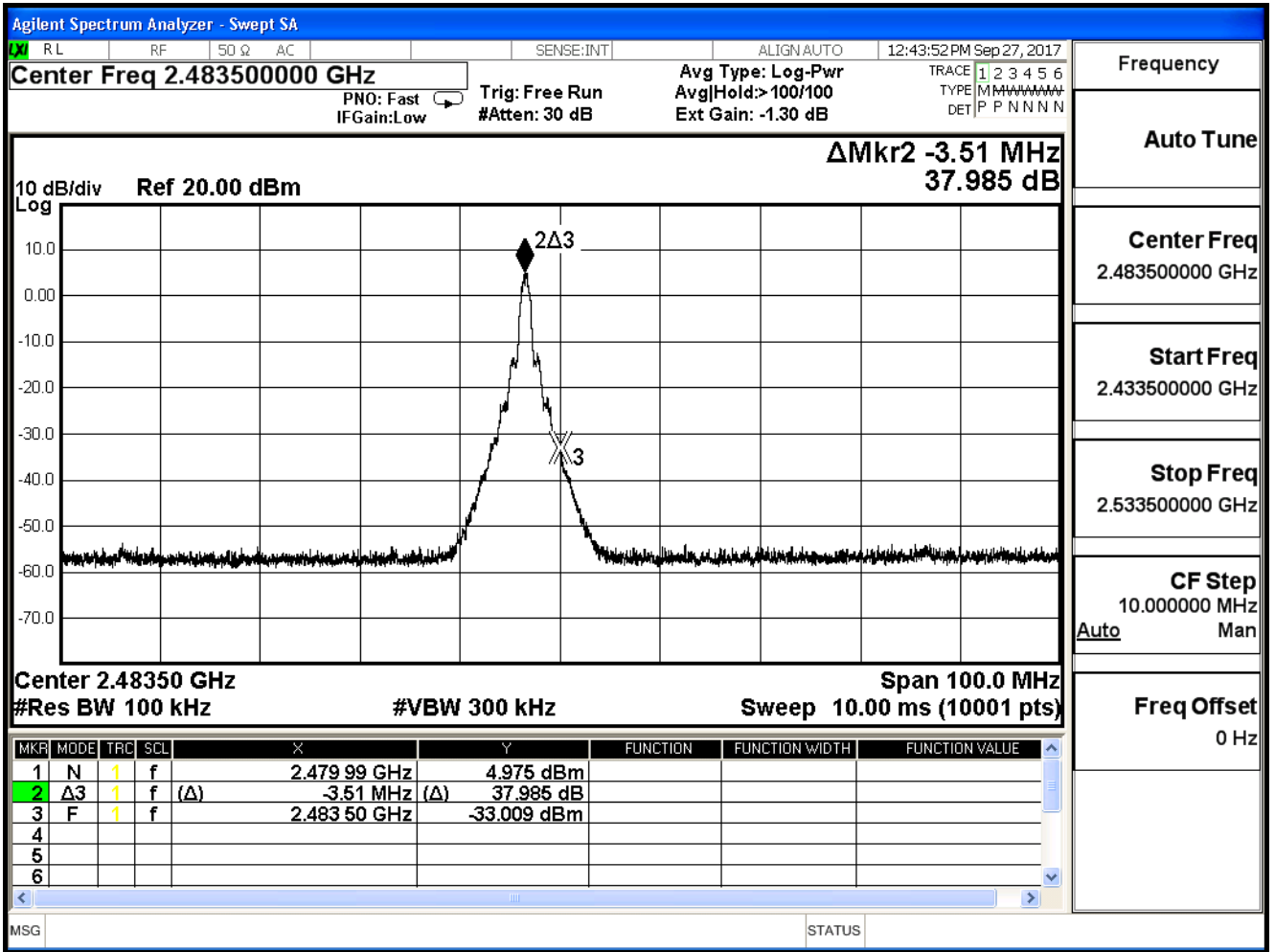

Product	Multimedia System		
Test Item	RF antenna conducted test		
Test Mode	Mode 1: Transmit		
Date of Test	2017/09/27	Test Site	SR10-H

8-DPSK

Channel	Frequency (MHz)	Measure Level (dBc)	Limit (dBc)	Result
00	2402	27.661	≥ 20	Pass
39	2441	58.985	≥ 20	Pass
78	2480	31.436	≥ 20	Pass

Channel 00

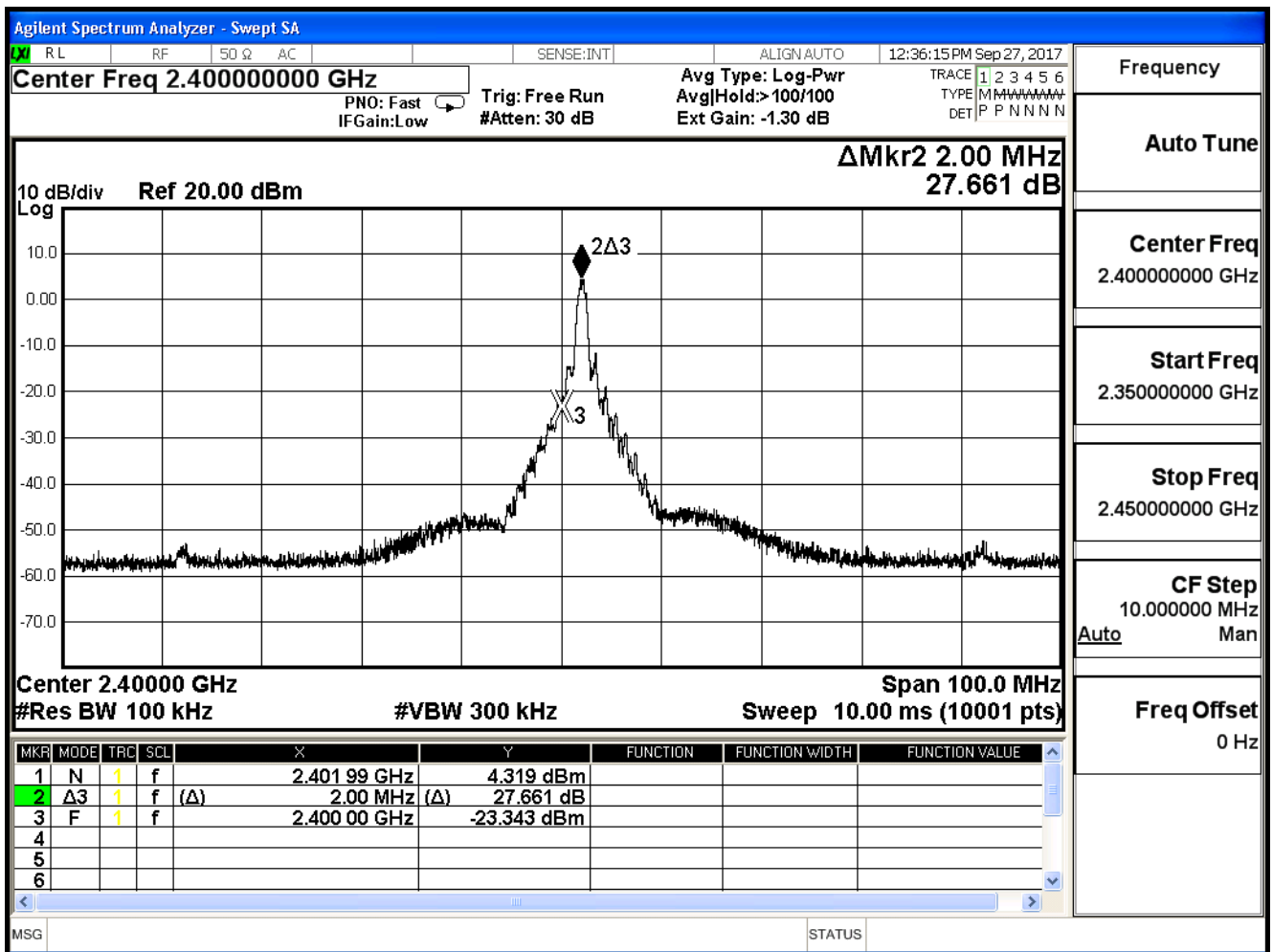

Channel 39

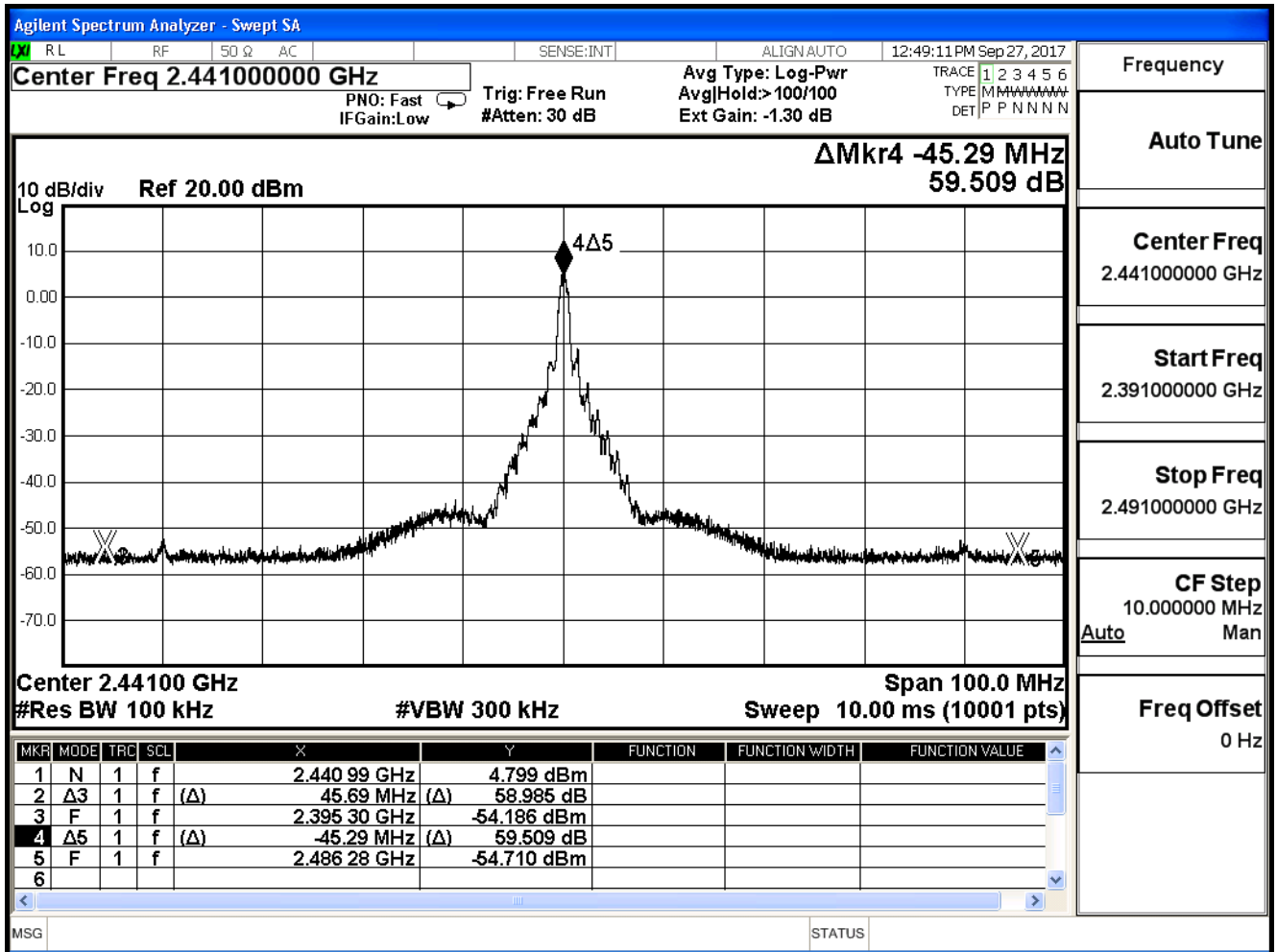

Channel 78

Agilent Spectrum Analyzer - Swept SA

RL RF 50 Ω AC SENSE:INT ALIGN:AUTO 12:40:35 PM Sep 27, 2017

Center Freq 2.48350000 GHz PNO: Fast Trig: Free Run Avg Type: Log-Pwr TRAC 1|2 3 4 5 6
 IF Gain: Low #Atten: 30 dB Avg|Hold:>100/100 Ext Gain: -1.30 dB TYPE: M M M M M M M M M M
 DET: P P N N N N N

ΔMkr2 -3.67 MHz
31.436 dB

10 dB/div Ref 20.00 dBm Log

Center 2.48350 GHz Span 100.0 MHz
 #Res BW 100 kHz #VBW 300 kHz Sweep 10.00 ms (10001 pts)

MKR	MODE	TRC	SCL	X	Y	FUNCTION	FUNCTION WIDTH	FUNCTION VALUE
1	N	1	f	2.479 83 GHz	5.009 dBm			
2	Δ3	1	f (Δ)	-3.67 MHz (Δ)	31.436 dB			
3	F	1	f	2.483 50 GHz	-26.427 dBm			
4								
5								
6								

Frequency: 2.483500000 GHz
 Auto Tune
 Center Freq: 2.483500000 GHz
 Start Freq: 2.433500000 GHz
 Stop Freq: 2.533500000 GHz
 CF Step: 10.000000 MHz
 Auto Man
 Freq Offset: 0 Hz

MSG STATUS

Product	Multimedia System		
Test Item	RF antenna conducted test		
Test Mode	Mode 1: Transmit		
Date of Test	2017/10/12	Test Site	SR10-H

Channel 00 (30MHz-25GHz)- GFSK

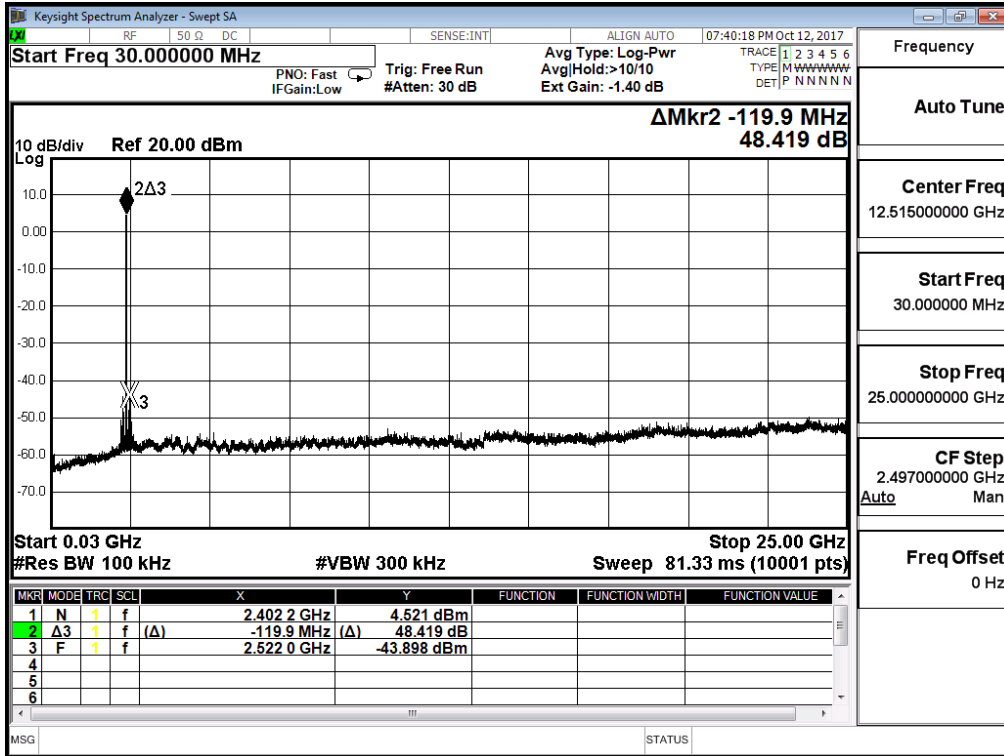

Channel 39 (30MHz-25GHz)- GFSK

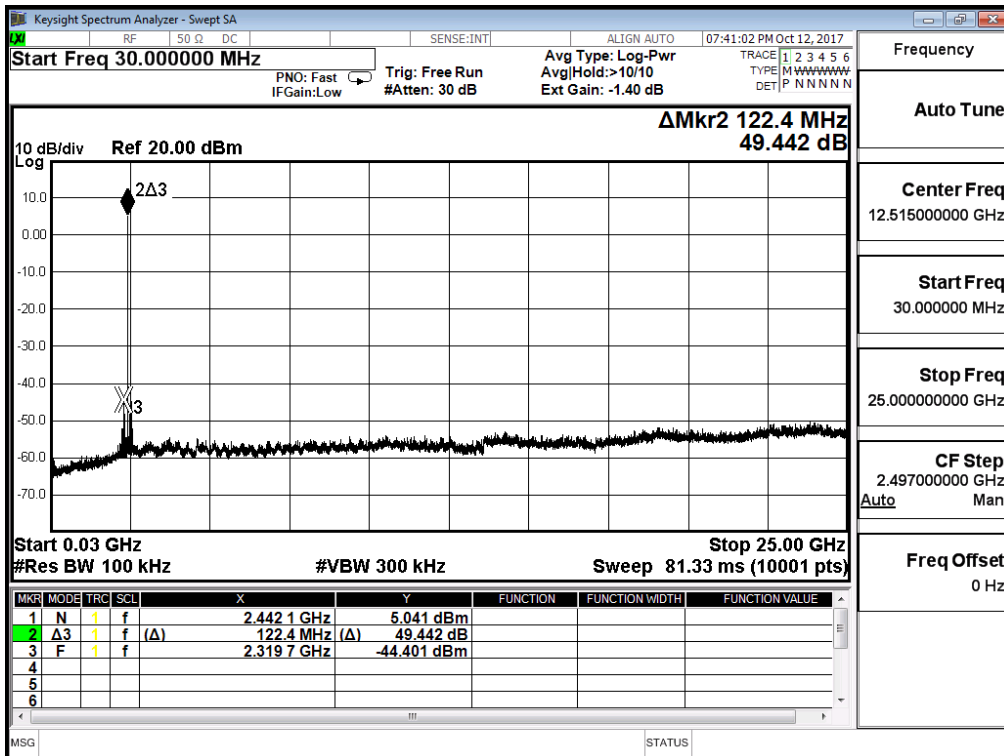

Channel 78 (30MHz-25GHz)- GFSK

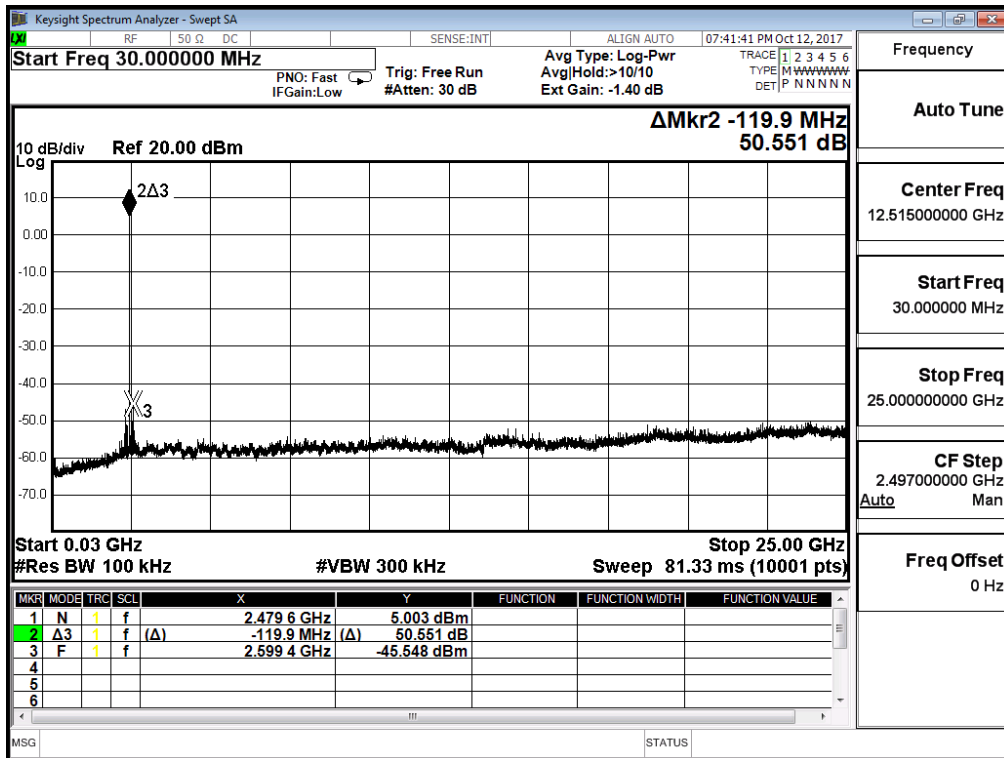

Channel 00 (30MHz-25GHz)- $\pi/4$ -DQPSK

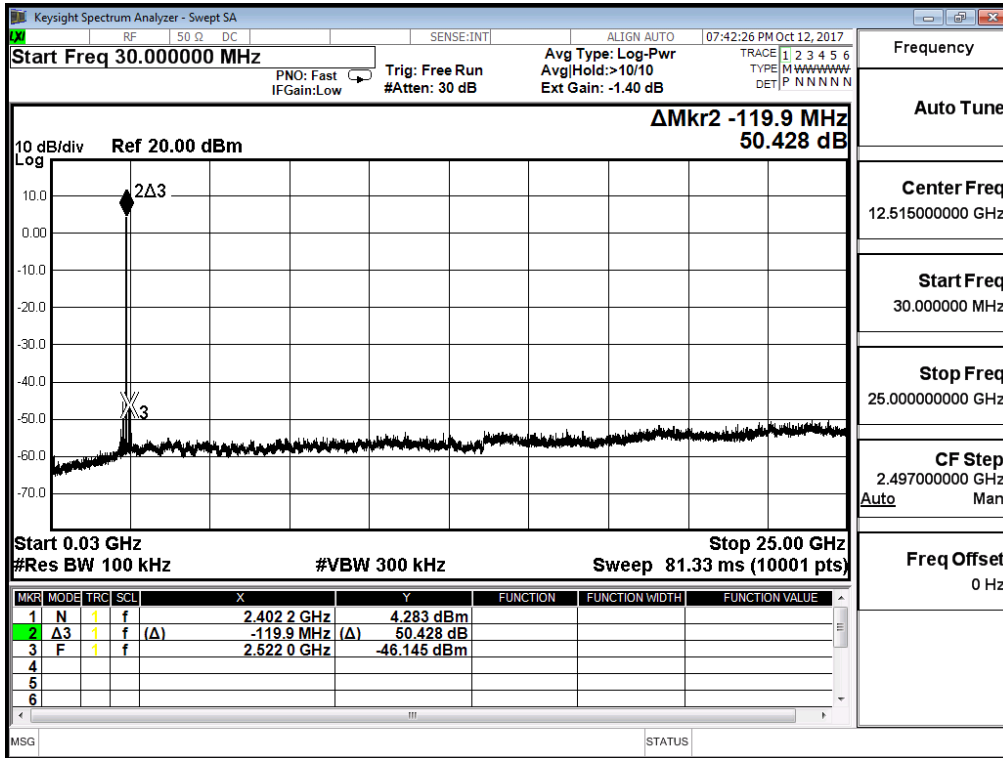

Channel 39 (30MHz-25GHz)- $\pi/4$ -DQPSK

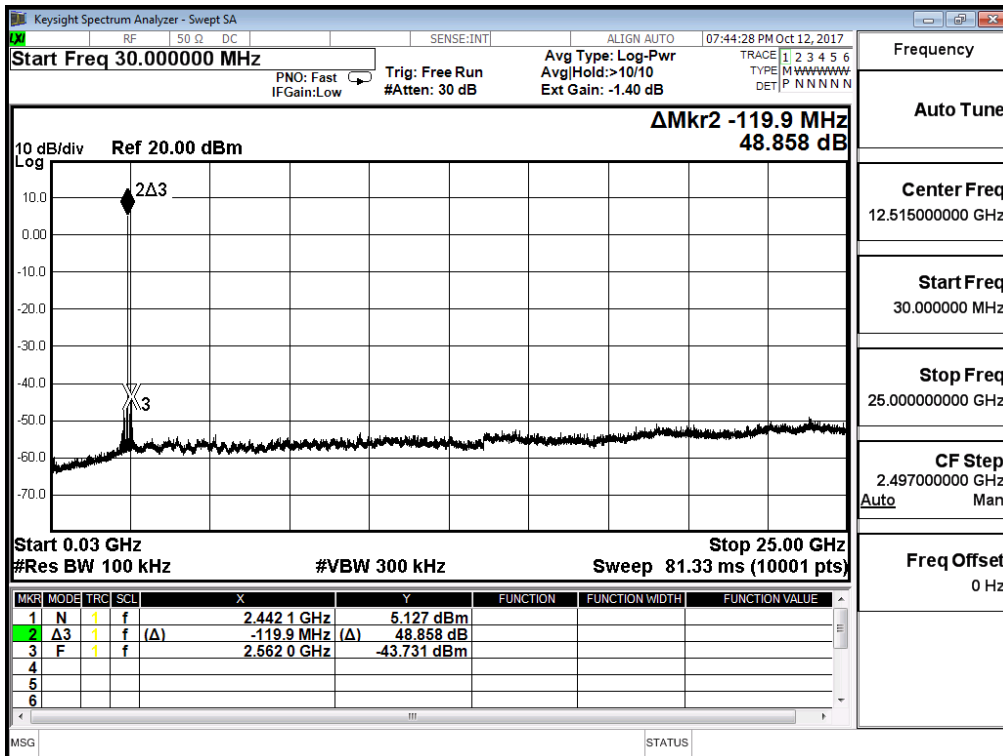

Channel 78 (30MHz-25GHz)- $\pi/4$ -DQPSK

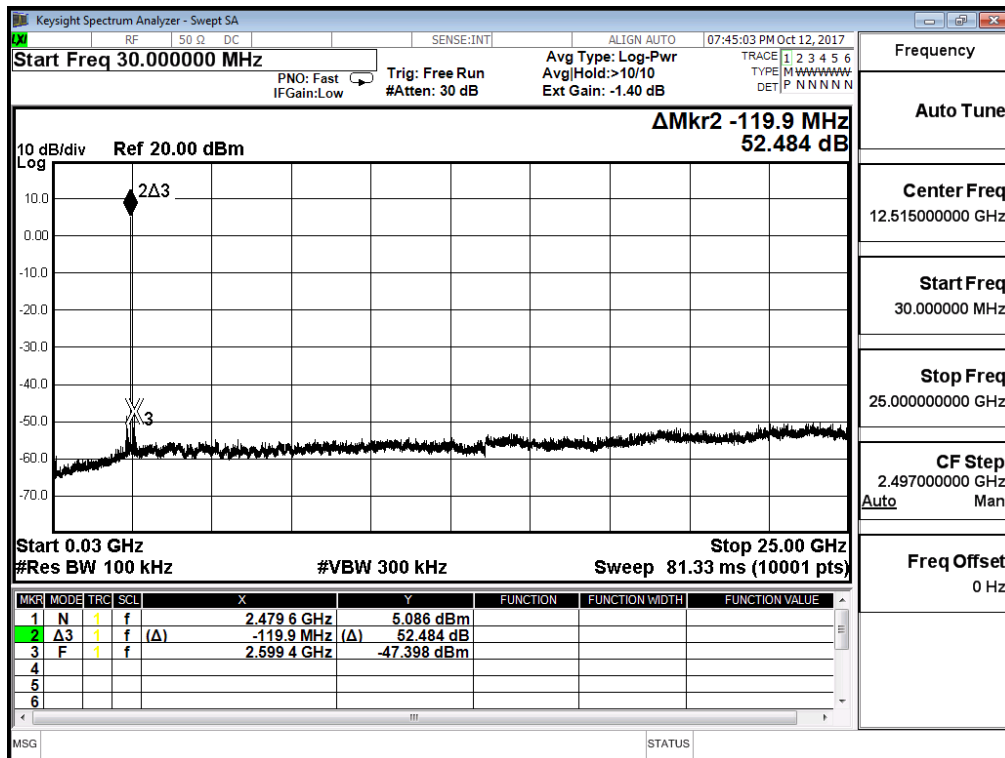

Channel 00 (30MHz-25GHz)- 8-DPSK

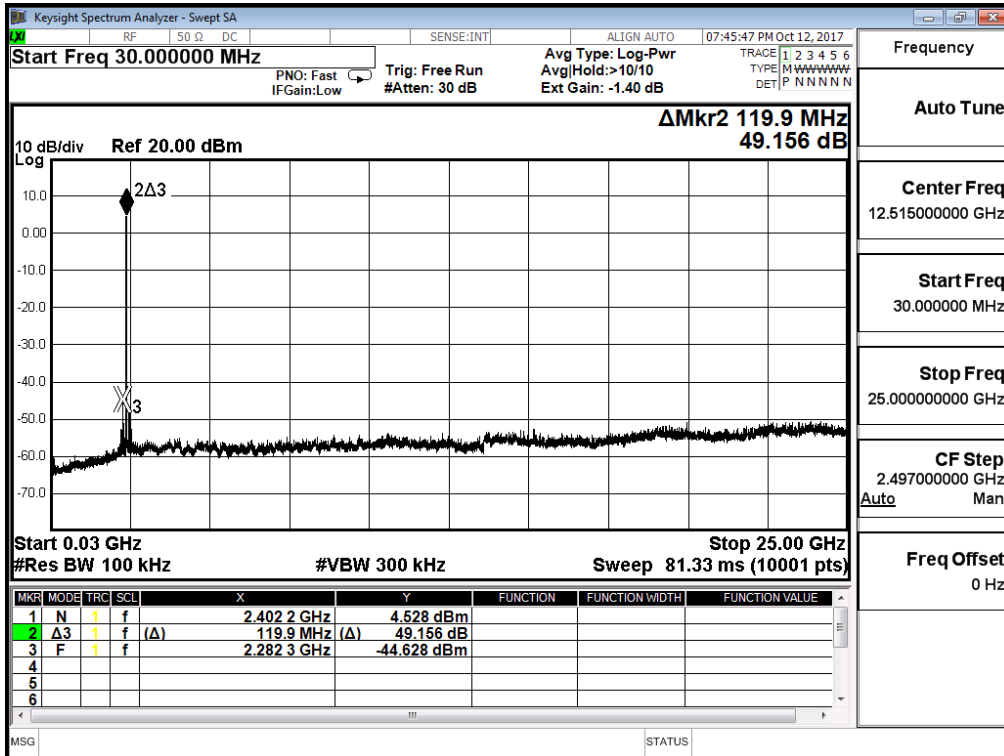

Channel 39 (30MHz-25GHz)- 8-DPSK

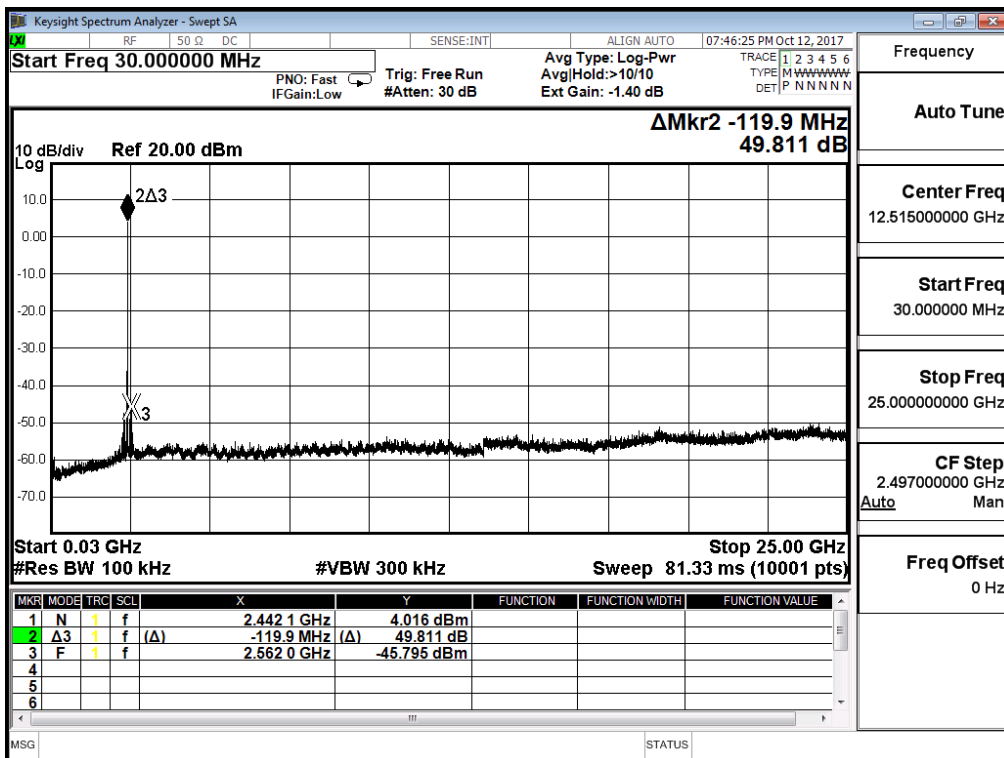

Channel 78 (30MHz-25GHz)- 8-DPSK

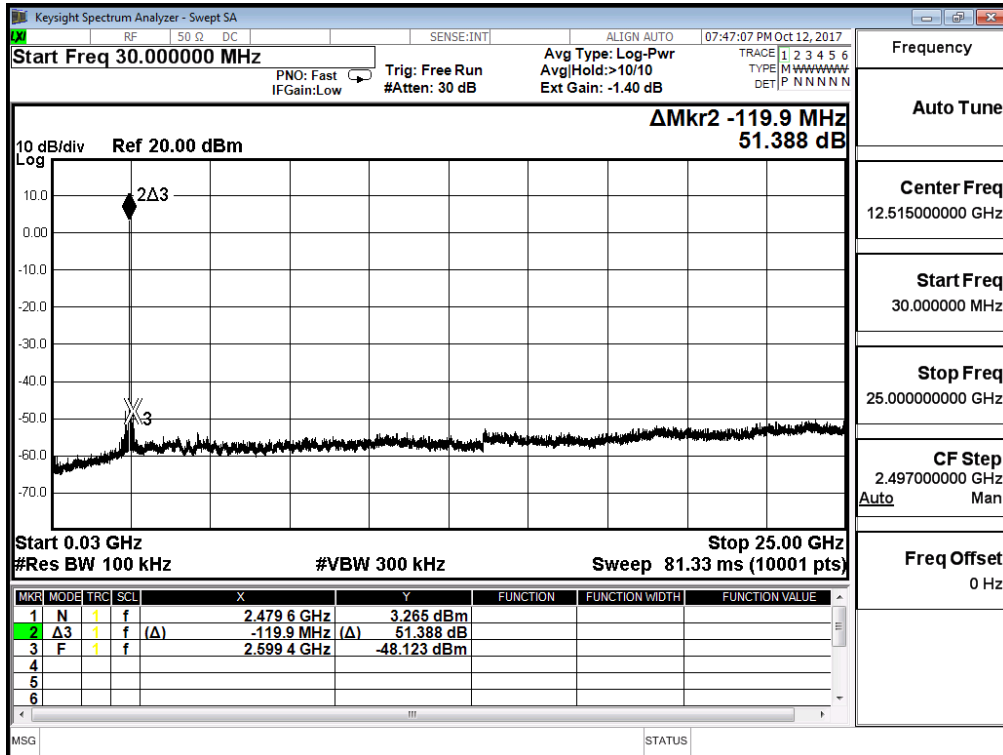

6. Band Edge

6.1. Test Equipment

The following test equipment are used during the test:

Band Edge / CB4-H

Instrument	Manufacturer	Model No.	Serial No	Next Cal. Date
Signal Analyzer	R&S	FSVA40	101455	2016/11/28
Signal & Spectrum Analyzer	R&S	FSV40	101049	2017/01/23
EXA Signal Analyzer	Keysight	N9010A	MY51440132	2017/03/13
Bilog Antenna	Teseq	CBL6112D	23191	2017/06/28
Horn Antenna	Schwarzbeck	BBHA 9120D	639	2017/06/14
Horn Antenna	Schwarzbeck	BBHA 9170	202	2017/02/15
Pre-Amplifier	RF Bay Inc.	LNA-1330	12162511	2017/03/09
Pre-Amplifier	EMCI	EMCI 1830I	980366	2017/01/23
Pre-Amplifier	MITEQ	JS44-45-8P	2014754	2016/12/26

Note: All equipment that need to calibrate are with calibration period of 1 year.

6.2. Test Setup

RF Radiated Measurement:

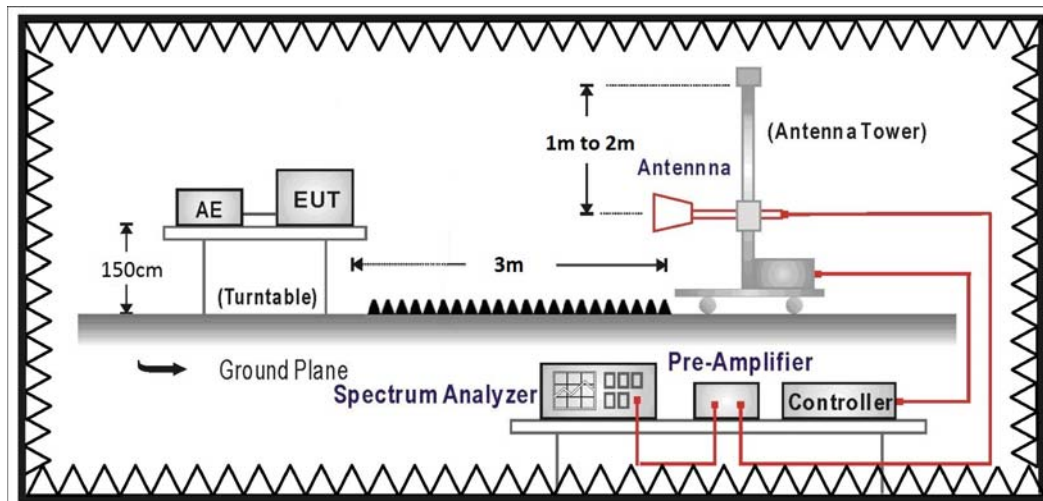

6.3. Limits

Emissions radiated outside of the specified frequency bands, except for harmonics, shall be attenuated by at least 20dB below the level of the fundamental or to the general radiated emission limits in paragraph 15.209, whichever is the lesser attenuation.

6.4. Test Procedure

The EUT was setup according to ANSI C63.10:2013 and tested according to FHSS test procedure of FCC Public Notice DA 00-705 for compliance to FCC 47CFR 15.247 requirements

The EUT and its simulators are placed on a turn table which is 1.5 meter above ground. The turn table can rotate 360 degrees to determine the position of the maximum emission level. The EUT was positioned such that the distance from antenna to the EUT was 3 meters.

The antenna can move up and down between 1 meter and 4 meters to find out the maximum emission level.

Both horizontal and vertical polarization of the antenna are set on measurement. In order to find the maximum emission, all of the interface cables must be manipulated according to ANSI C63.10:2013 on radiated measurement.

6.5. Test Specification

According to FCC Part 15 Subpart C Paragraph 15.247: 2015

6.6. Test Result

Site : CB4-H	Time : 2017/09/24
Limit : FCC_SpartC_15.209_03M_PK	Margin : 6
Probe : CB4-H_FCC_A115_EFS_1-18GHz_1116 - HORIZONTAL	Power : DC 12V
EUT : Multimedia System	Note : DH5_2402MHz

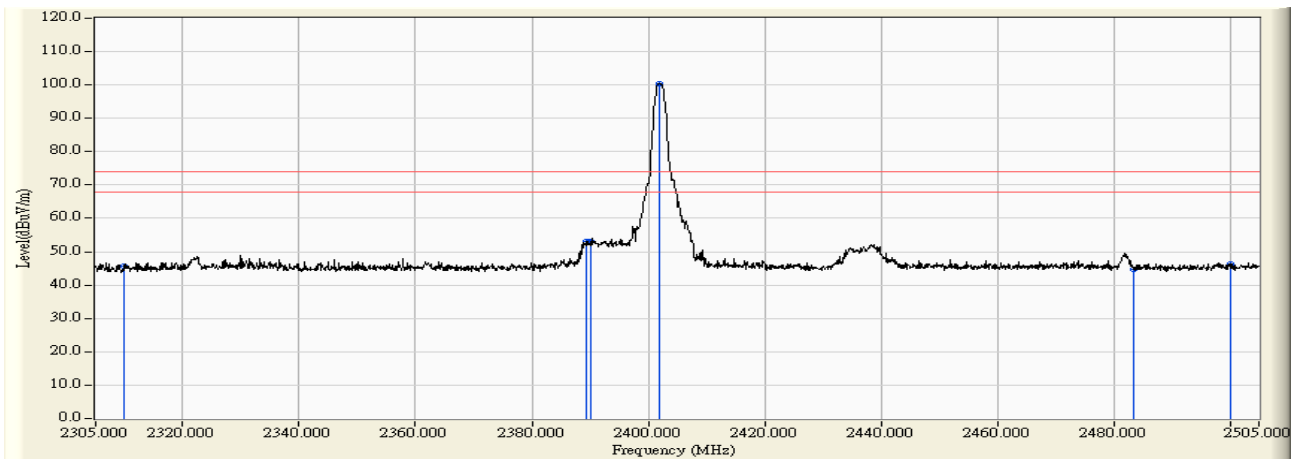

	Frequency (MHz)	Correct Factor (dB)	Reading Level (dBuV)	Measure Level (dBuV/m)	Margin (dB)	Limit (dBuV/m)	Detector Type
1	2310.000	13.428	32.339	45.767	-28.233	74.000	PEAK
2	2389.400	13.973	38.986	52.959	-21.041	74.000	PEAK
3	2390.000	13.977	39.257	53.234	-20.766	74.000	PEAK
4	* 2401.800	14.057	86.260	100.318	26.318	74.000	PEAK
5	2483.500	14.619	30.160	44.779	-29.221	74.000	PEAK
6	2500.000	14.728	31.564	46.292	-27.708	74.000	PEAK

Note:

1. All readings above 1GHz are performed with peak and/or average measurements as necessary.
2. Peak measurements: RBW = 1MHz, VBW = 1MHz, Sweep: Auto.
3. Average measurements: RBW = 1MHz, VBW = 10 Hz, Sweep: Auto.
4. “ * ”, means this data is the worst emission level.
5. Measurement Level = Reading Level + Correct Factor.
6. The average measurement was not performed when the peak measured data under the limit of average detection. If the readings given are average, peak measurement should also be supplied.

Site : CB4-H	Time : 2017/09/24
Limit : FCC_SpartC_15.209_03M_AV	Margin : 6
Probe : CB4-H_FCC_A115_EFS_1-18GHz_1116 - HORIZONTAL	Power : DC 12V
EUT : Multimedia System	Note : DH5_2402MHz

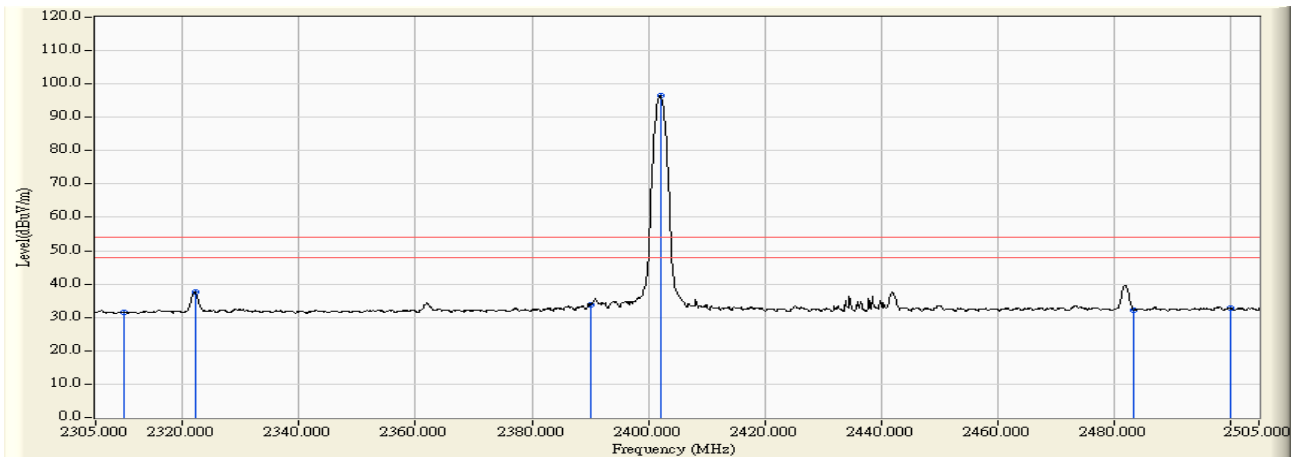

	Frequency (MHz)	Correct Factor (dB)	Reading Level (dBuV)	Measure Level (dBuV/m)	Margin (dB)	Limit (dBuV/m)	Detector Type
1	2310.000	13.428	18.171	31.599	-22.401	54.000	AVERAGE
2	2322.100	13.512	24.094	37.605	-16.395	54.000	AVERAGE
3	2390.000	13.977	19.829	33.806	-20.194	54.000	AVERAGE
4	* 2402.100	14.061	82.345	96.405	42.405	54.000	AVERAGE
5	2483.500	14.619	17.543	32.162	-21.838	54.000	AVERAGE
6	2500.000	14.728	18.039	32.767	-21.233	54.000	AVERAGE

Note:

1. All readings above 1GHz are performed with peak and/or average measurements as necessary.
2. Peak measurements: RBW = 1MHz, VBW = 1MHz, Sweep: Auto.
3. Average measurements: RBW = 1MHz, VBW = 10 Hz, Sweep: Auto.
4. “ * ”, means this data is the worst emission level.
5. Measurement Level = Reading Level + Correct Factor.
6. The average measurement was not performed when the peak measured data under the limit of average detection. If the readings given are average, peak measurement should also be supplied.

Site : CB4-H	Time : 2017/09/24
Limit : FCC_SpartC_15.209_03M_PK	Margin : 6
Probe : CB4-H_FCC_A115_EFS_1-18GHz_1116 - VERTICAL	Power : DC 12V
EUT : Multimedia System	Note : DH5_2402MHz

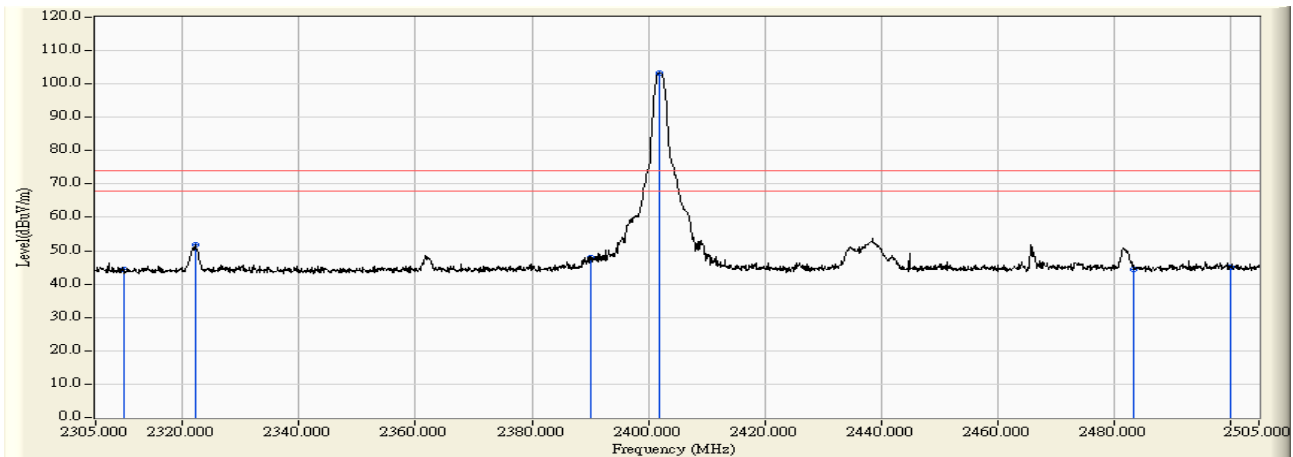

	Frequency (MHz)	Correct Factor (dB)	Reading Level (dBuV)	Measure Level (dBuV/m)	Margin (dB)	Limit (dBuV/m)	Detector Type
1	2310.000	13.428	30.897	44.325	-29.675	74.000	PEAK
2	2322.100	13.512	38.156	51.667	-22.333	74.000	PEAK
3	2390.000	13.977	33.986	47.963	-26.037	74.000	PEAK
4	* 2401.900	14.059	89.197	103.256	29.256	74.000	PEAK
5	2483.500	14.619	29.891	44.510	-29.490	74.000	PEAK
6	2500.000	14.728	30.346	45.074	-28.926	74.000	PEAK

Note:

1. All readings above 1GHz are performed with peak and/or average measurements as necessary.
2. Peak measurements: RBW = 1MHz, VBW = 1MHz, Sweep: Auto.
3. Average measurements: RBW = 1MHz, VBW = 10 Hz, Sweep: Auto.
4. “ * ”, means this data is the worst emission level.
5. Measurement Level = Reading Level + Correct Factor.
6. The average measurement was not performed when the peak measured data under the limit of average detection. If the readings given are average, peak measurement should also be supplied.

Site : CB4-H	Time : 2017/09/24
Limit : FCC_SpartC_15.209_03M_AV	Margin : 6
Probe : CB4-H_FCC_A115_EFS_1-18GHz_1116 - VERTICAL	Power : DC 12V
EUT : Multimedia System	Note : DH5_2402MHz

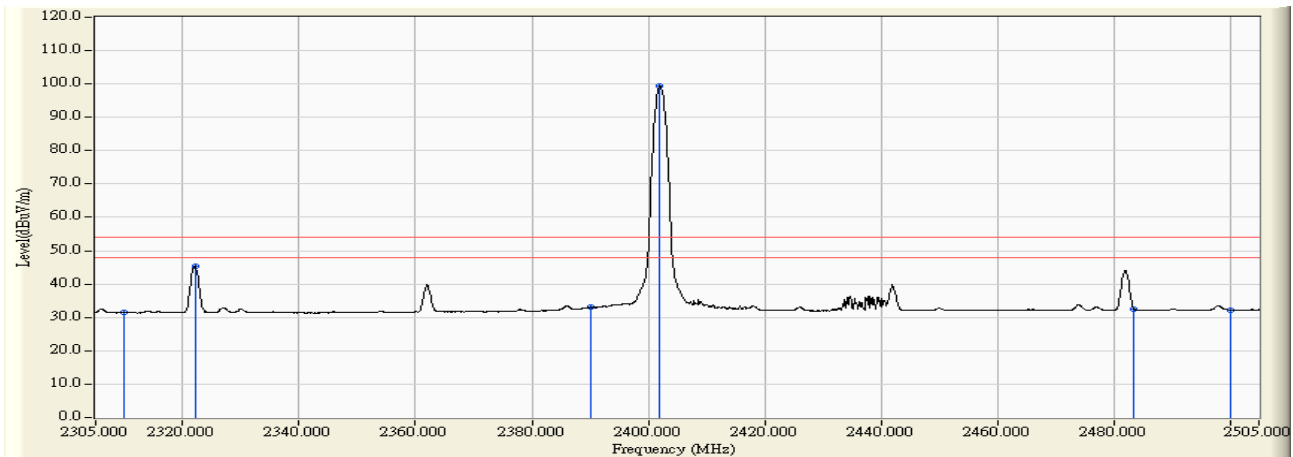

	Frequency (MHz)	Correct Factor (dB)	Reading Level (dBuV)	Measure Level (dBuV/m)	Margin (dB)	Limit (dBuV/m)	Detector Type
1	2310.000	13.428	18.079	31.507	-22.493	54.000	AVERAGE
2	2322.100	13.512	31.801	45.312	-8.688	54.000	AVERAGE
3	2390.000	13.977	19.025	33.002	-20.998	54.000	AVERAGE
4	* 2402.000	14.060	85.351	99.411	45.411	54.000	AVERAGE
5	2483.500	14.619	17.926	32.545	-21.455	54.000	AVERAGE
6	2500.000	14.728	17.580	32.308	-21.692	54.000	AVERAGE

Note:

1. All readings above 1GHz are performed with peak and/or average measurements as necessary.
2. Peak measurements: RBW = 1MHz, VBW = 1MHz, Sweep: Auto.
3. Average measurements: RBW = 1MHz, VBW = 10 Hz, Sweep: Auto.
4. “ * ”, means this data is the worst emission level.
5. Measurement Level = Reading Level + Correct Factor.
6. The average measurement was not performed when the peak measured data under the limit of average detection. If the readings given are average, peak measurement should also be supplied.

Site : CB4-H	Time : 2017/09/24
Limit : FCC_SpartC_15.209_03M_PK	Margin : 6
Probe : CB4-H_FCC_A115_EFS_1-18GHz_1116 - HORIZONTAL	Power : DC 12V
EUT : Multimedia System	Note : DH5_2441MHz

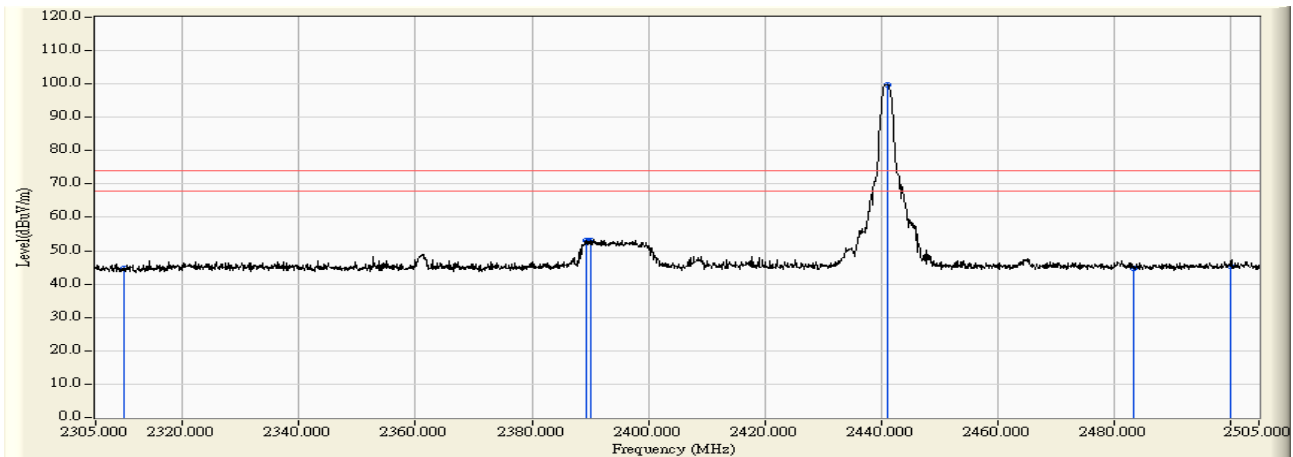

	Frequency (MHz)	Correct Factor (dB)	Reading Level (dBuV)	Measure Level (dBuV/m)	Margin (dB)	Limit (dBuV/m)	Detector Type
1	2310.000	13.428	31.371	44.799	-29.201	74.000	PEAK
2	2389.300	13.972	39.270	53.242	-20.758	74.000	PEAK
3	2390.000	13.977	38.999	52.976	-21.024	74.000	PEAK
4	* 2441.200	14.328	85.377	99.706	25.706	74.000	PEAK
5	2483.500	14.619	30.137	44.756	-29.244	74.000	PEAK
6	2500.000	14.728	30.537	45.265	-28.735	74.000	PEAK

Note:

1. All readings above 1GHz are performed with peak and/or average measurements as necessary.
2. Peak measurements: RBW = 1MHz, VBW = 1MHz, Sweep: Auto.
3. Average measurements: RBW = 1MHz, VBW = 10 Hz, Sweep: Auto.
4. “ * ”, means this data is the worst emission level.
5. Measurement Level = Reading Level + Correct Factor.
6. The average measurement was not performed when the peak measured data under the limit of average detection. If the readings given are average, peak measurement should also be supplied.

Site : CB4-H	Time : 2017/09/24
Limit : FCC_SpartC_15.209_03M_AV	Margin : 6
Probe : CB4-H_FCC_A115_EFS_1-18GHz_1116 - HORIZONTAL	Power : DC 12V
EUT : Multimedia System	Note : DH5_2441MHz

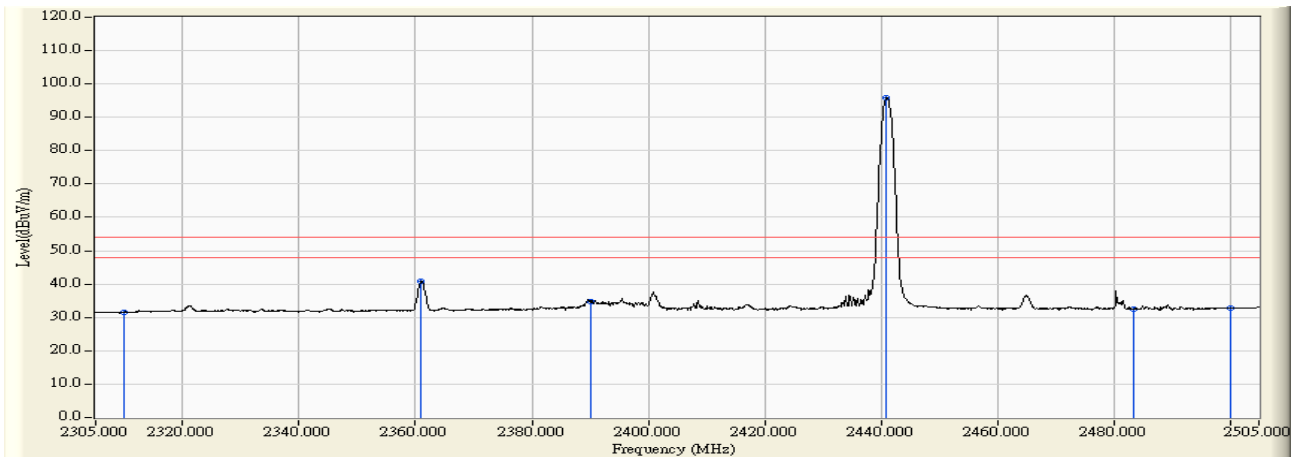

	Frequency (MHz)	Correct Factor (dB)	Reading Level (dBuV)	Measure Level (dBuV/m)	Margin (dB)	Limit (dBuV/m)	Detector Type
1	2310.000	13.428	18.226	31.654	-22.346	54.000	AVERAGE
2	2360.900	13.778	26.991	40.768	-13.232	54.000	AVERAGE
3	2390.000	13.977	20.749	34.726	-19.274	54.000	AVERAGE
4	* 2441.000	14.328	81.456	95.783	41.783	54.000	AVERAGE
5	2483.500	14.619	17.924	32.543	-21.457	54.000	AVERAGE
6	2500.000	14.728	17.977	32.705	-21.295	54.000	AVERAGE

Note:

1. All readings above 1GHz are performed with peak and/or average measurements as necessary.
2. Peak measurements: RBW = 1MHz, VBW = 1MHz, Sweep: Auto.
3. Average measurements: RBW = 1MHz, VBW = 10 Hz, Sweep: Auto.
4. “ * ”, means this data is the worst emission level.
5. Measurement Level = Reading Level + Correct Factor.
6. The average measurement was not performed when the peak measured data under the limit of average detection. If the readings given are average, peak measurement should also be supplied.

Site : CB4-H	Time : 2017/09/24
Limit : FCC_SpartC_15.209_03M_PK	Margin : 6
Probe : CB4-H_FCC_A115_EFS_1-18GHz_1116 - VERTICAL	Power : DC 12V
EUT : Multimedia System	Note : DH5_2441MHz

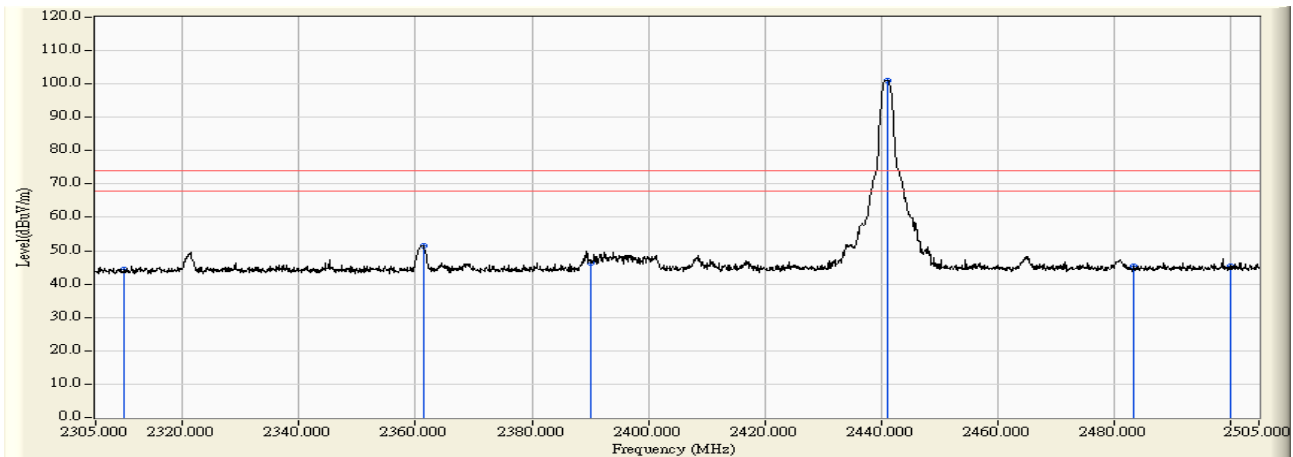

	Frequency (MHz)	Correct Factor (dB)	Reading Level (dBuV)	Measure Level (dBuV/m)	Margin (dB)	Limit (dBuV/m)	Detector Type
1	2310.000	13.428	30.918	44.346	-29.654	74.000	PEAK
2	2361.300	13.780	37.562	51.342	-22.658	74.000	PEAK
3	2390.000	13.977	32.397	46.374	-27.626	74.000	PEAK
4	* 2441.200	14.328	86.786	101.115	27.115	74.000	PEAK
5	2483.500	14.619	30.837	45.456	-28.544	74.000	PEAK
6	2500.000	14.728	30.562	45.290	-28.710	74.000	PEAK

Note:

1. All readings above 1GHz are performed with peak and/or average measurements as necessary.
2. Peak measurements: RBW = 1MHz, VBW = 1MHz, Sweep: Auto.
3. Average measurements: RBW = 1MHz, VBW = 10 Hz, Sweep: Auto.
4. “ * ”, means this data is the worst emission level.
5. Measurement Level = Reading Level + Correct Factor.
6. The average measurement was not performed when the peak measured data under the limit of average detection. If the readings given are average, peak measurement should also be supplied.

Site : CB4-H	Time : 2017/09/24
Limit : FCC_SpartC_15.209_03M_AV	Margin : 6
Probe : CB4-H_FCC_A115_EFS_1-18GHz_1116 - VERTICAL	Power : DC 12V
EUT : Multimedia System	Note : DH5_2441MHz

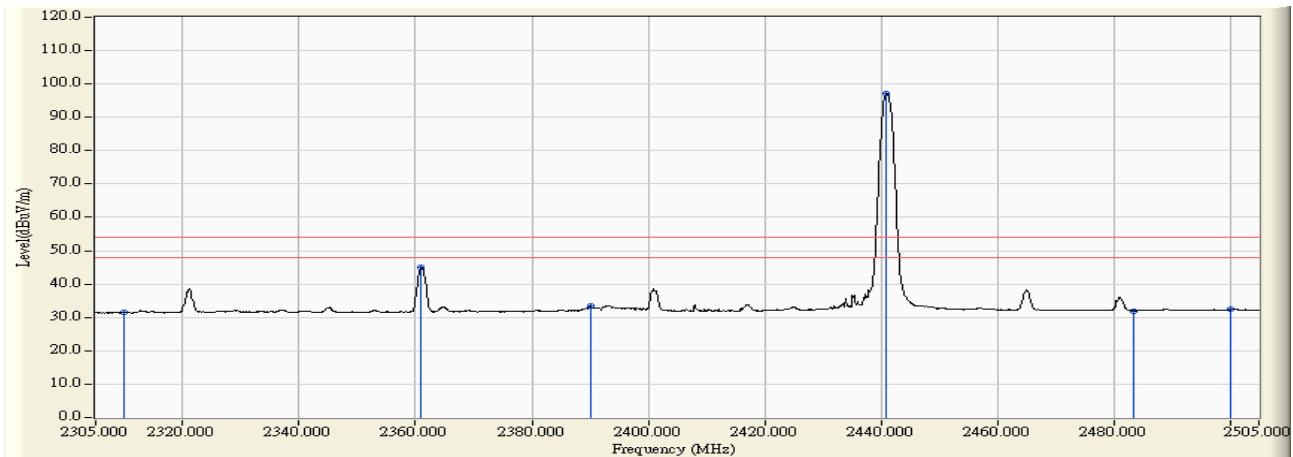

	Frequency (MHz)	Correct Factor (dB)	Reading Level (dBuV)	Measure Level (dBuV/m)	Margin (dB)	Limit (dBuV/m)	Detector Type
1	2310.000	13.428	18.043	31.471	-22.529	54.000	AVERAGE
2	2360.900	13.778	31.205	44.982	-9.018	54.000	AVERAGE
3	2390.000	13.977	19.396	33.373	-20.627	54.000	AVERAGE
4	* 2441.000	14.328	82.973	97.300	43.300	54.000	AVERAGE
5	2483.500	14.619	17.359	31.978	-22.022	54.000	AVERAGE
6	2500.000	14.728	17.617	32.345	-21.655	54.000	AVERAGE

Note:

1. All readings above 1GHz are performed with peak and/or average measurements as necessary.
2. Peak measurements: RBW = 1MHz, VBW = 1MHz, Sweep: Auto.
3. Average measurements: RBW = 1MHz, VBW = 10 Hz, Sweep: Auto.
4. “ * ”, means this data is the worst emission level.
5. Measurement Level = Reading Level + Correct Factor.
6. The average measurement was not performed when the peak measured data under the limit of average detection. If the readings given are average, peak measurement should also be supplied.

Site : CB4-H	Time : 2017/09/24
Limit : FCC_SpartC_15.209_03M_PK	Margin : 6
Probe : CB4-H_FCC_A115_EFS_1-18GHz_1116 - HORIZONTAL	Power : DC 12V
EUT : Multimedia System	Note : DH5_2480MHz

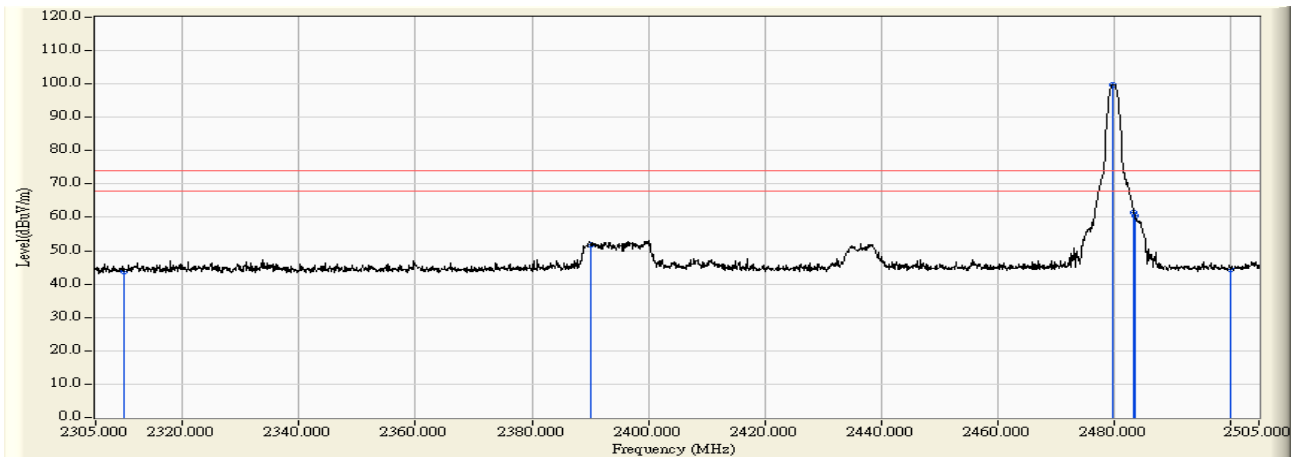

	Frequency (MHz)	Correct Factor (dB)	Reading Level (dBuV)	Measure Level (dBuV/m)	Margin (dB)	Limit (dBuV/m)	Detector Type
1	2310.000	13.428	30.166	43.594	-30.406	74.000	PEAK
2	2390.000	13.977	37.830	51.807	-22.193	74.000	PEAK
3	* 2479.900	14.595	85.264	99.858	25.858	74.000	PEAK
4	2483.500	14.619	46.884	61.503	-12.497	74.000	PEAK
5	2483.600	14.619	45.729	60.349	-13.651	74.000	PEAK
6	2500.000	14.728	29.640	44.368	-29.632	74.000	PEAK

Note:

1. All readings above 1GHz are performed with peak and/or average measurements as necessary.
2. Peak measurements: RBW = 1MHz, VBW = 1MHz, Sweep: Auto.
3. Average measurements: RBW = 1MHz, VBW = 10 Hz, Sweep: Auto.
4. “ * ”, means this data is the worst emission level.
5. Measurement Level = Reading Level + Correct Factor.
6. The average measurement was not performed when the peak measured data under the limit of average detection. If the readings given are average, peak measurement should also be supplied.

Site : CB4-H	Time : 2017/09/24
Limit : FCC_SpartC_15.209_03M_AV	Margin : 6
Probe : CB4-H_FCC_A115_EFS_1-18GHz_1116 - HORIZONTAL	Power : DC 12V
EUT : Multimedia System	Note : DH5_2480MHz

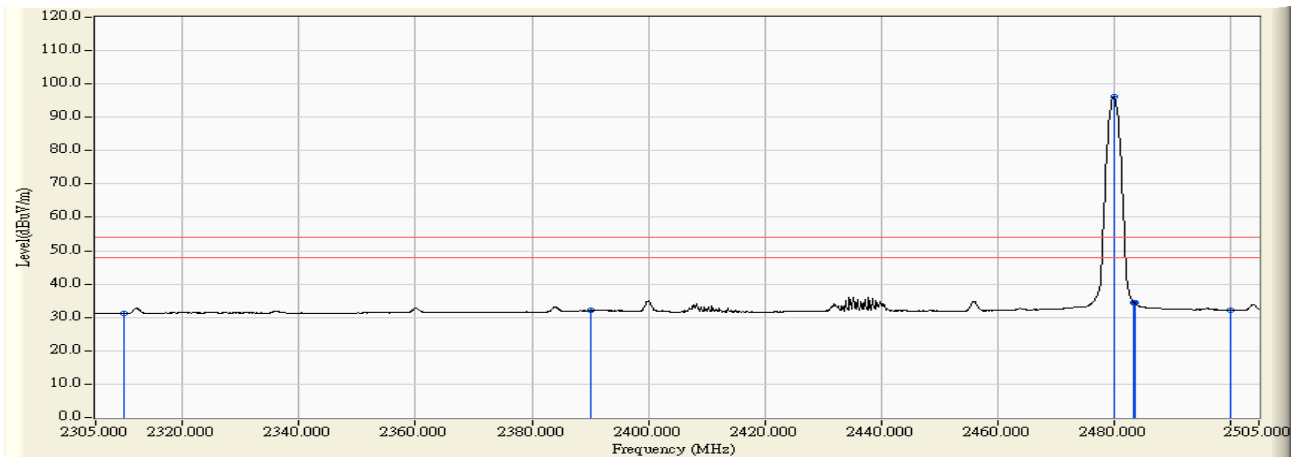

	Frequency (MHz)	Correct Factor (dB)	Reading Level (dBuV)	Measure Level (dBuV/m)	Margin (dB)	Limit (dBuV/m)	Detector Type
1	2310.000	13.428	17.836	31.264	-22.736	54.000	AVERAGE
2	2390.000	13.977	18.055	32.032	-21.968	54.000	AVERAGE
3	* 2480.100	14.595	81.473	96.069	42.069	54.000	AVERAGE
4	2483.500	14.619	19.939	34.558	-19.442	54.000	AVERAGE
5	2483.600	14.619	19.709	34.329	-19.671	54.000	AVERAGE
6	2500.000	14.728	17.491	32.219	-21.781	54.000	AVERAGE

Note:

1. All readings above 1GHz are performed with peak and/or average measurements as necessary.
2. Peak measurements: RBW = 1MHz, VBW = 1MHz, Sweep: Auto.
3. Average measurements: RBW = 1MHz, VBW = 10 Hz, Sweep: Auto.
4. “ * ”, means this data is the worst emission level.
5. Measurement Level = Reading Level + Correct Factor.
6. The average measurement was not performed when the peak measured data under the limit of average detection. If the readings given are average, peak measurement should also be supplied.

Site : CB4-H	Time : 2017/09/24
Limit : FCC_SpartC_15.209_03M_PK	Margin : 6
Probe : CB4-H_FCC_A115_EFS_1-18GHz_1116 - VERTICAL	Power : DC 12V
EUT : Multimedia System	Note : DH5_2480MHz

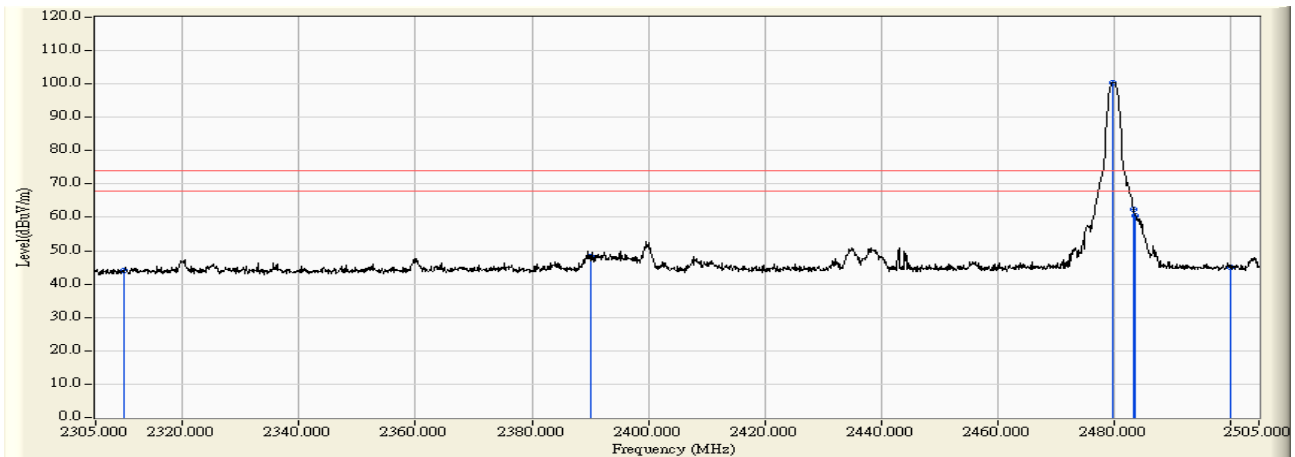

	Frequency (MHz)	Correct Factor (dB)	Reading Level (dBuV)	Measure Level (dBuV/m)	Margin (dB)	Limit (dBuV/m)	Detector Type
1	2310.000	13.428	30.709	44.137	-29.863	74.000	PEAK
2	2390.000	13.977	34.263	48.240	-25.760	74.000	PEAK
3	* 2479.800	14.594	85.892	100.485	26.485	74.000	PEAK
4	2483.500	14.619	47.748	62.367	-11.633	74.000	PEAK
5	2483.600	14.619	45.706	60.326	-13.674	74.000	PEAK
6	2500.000	14.728	30.359	45.087	-28.913	74.000	PEAK

Note:

1. All readings above 1GHz are performed with peak and/or average measurements as necessary.
2. Peak measurements: RBW = 1MHz, VBW = 1MHz, Sweep: Auto.
3. Average measurements: RBW = 1MHz, VBW = 10 Hz, Sweep: Auto.
4. “ * ”, means this data is the worst emission level.
5. Measurement Level = Reading Level + Correct Factor.
6. The average measurement was not performed when the peak measured data under the limit of average detection. If the readings given are average, peak measurement should also be supplied.

Site : CB4-H	Time : 2017/09/24
Limit : FCC_SpartC_15.209_03M_AV	Margin : 6
Probe : CB4-H_FCC_A115_EFS_1-18GHz_1116 - VERTICAL	Power : DC 12V
EUT : Multimedia System	Note : DH5_2480MHz

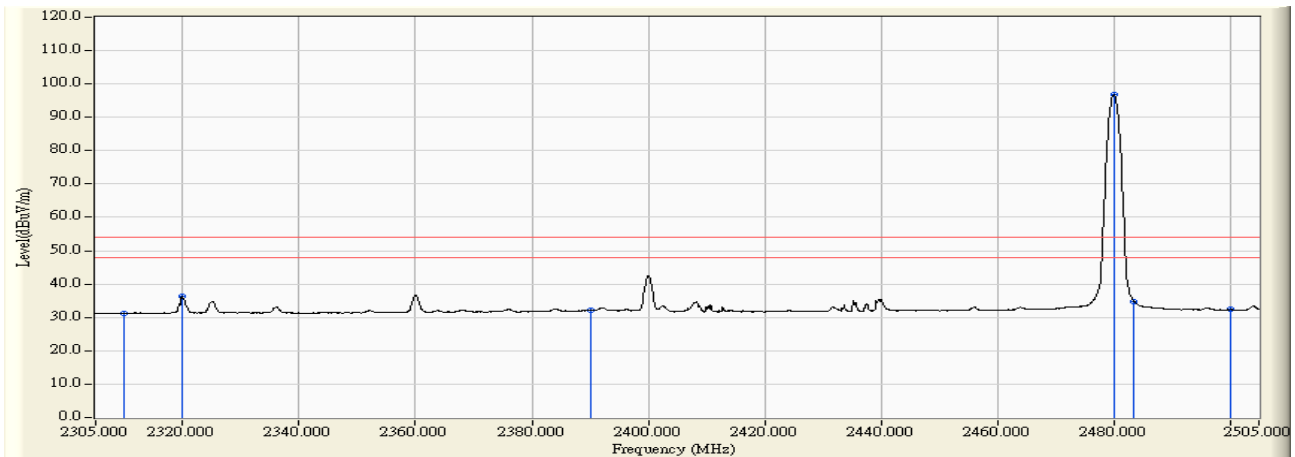

	Frequency (MHz)	Correct Factor (dB)	Reading Level (dBuV)	Measure Level (dBuV/m)	Margin (dB)	Limit (dBuV/m)	Detector Type
1	2310.000	13.428	17.784	31.212	-22.788	54.000	AVERAGE
2	2319.800	13.495	22.775	36.270	-17.730	54.000	AVERAGE
3	2390.000	13.977	18.282	32.259	-21.741	54.000	AVERAGE
4	* 2480.000	14.595	82.246	96.841	42.841	54.000	AVERAGE
5	2483.500	14.619	20.287	34.906	-19.094	54.000	AVERAGE
6	2500.000	14.728	17.605	32.333	-21.667	54.000	AVERAGE

Note:

1. All readings above 1GHz are performed with peak and/or average measurements as necessary.
2. Peak measurements: RBW = 1MHz, VBW = 1MHz, Sweep: Auto.
3. Average measurements: RBW = 1MHz, VBW = 10 Hz, Sweep: Auto.
4. “ * ”, means this data is the worst emission level.
5. Measurement Level = Reading Level + Correct Factor.
6. The average measurement was not performed when the peak measured data under the limit of average detection. If the readings given are average, peak measurement should also be supplied.

Site : CB4-H	Time : 2017/09/24
Limit : FCC_SpartC_15.209_03M_PK	Margin : 6
Probe : CB4-H_FCC_A115_EFS_1-18GHz_1116 - HORIZONTAL	Power : DC 12V
EUT : Multimedia System	Note : 2DH5_2402MHz

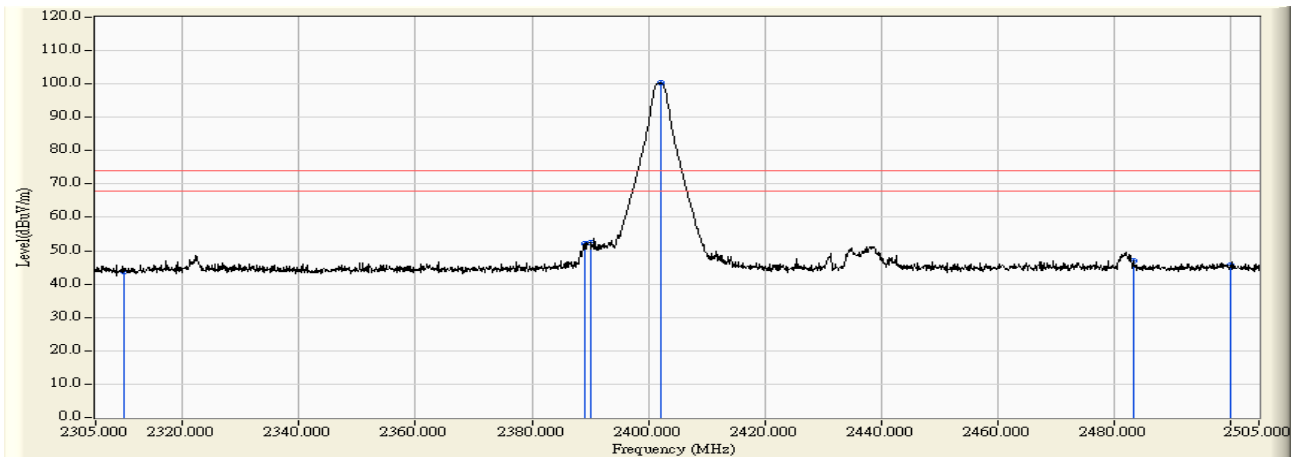

	Frequency (MHz)	Correct Factor (dB)	Reading Level (dBuV)	Measure Level (dBuV/m)	Margin (dB)	Limit (dBuV/m)	Detector Type
1	2310.000	13.428	30.227	43.655	-30.345	74.000	PEAK
2	2389.000	13.970	38.289	52.259	-21.741	74.000	PEAK
3	2390.000	13.977	38.384	52.361	-21.639	74.000	PEAK
4	* 2402.100	14.061	86.200	100.260	26.260	74.000	PEAK
5	2483.500	14.619	32.446	47.065	-26.935	74.000	PEAK
6	2500.000	14.728	30.863	45.591	-28.409	74.000	PEAK

Note:

1. All readings above 1GHz are performed with peak and/or average measurements as necessary.
2. Peak measurements: RBW = 1MHz, VBW = 1MHz, Sweep: Auto.
3. Average measurements: RBW = 1MHz, VBW = 10 Hz, Sweep: Auto.
4. “ * ”, means this data is the worst emission level.
5. Measurement Level = Reading Level + Correct Factor.
6. The average measurement was not performed when the peak measured data under the limit of average detection. If the readings given are average, peak measurement should also be supplied.

Site : CB4-H	Time : 2017/09/24
Limit : FCC_SpartC_15.209_03M_AV	Margin : 6
Probe : CB4-H_FCC_A115_EFS_1-18GHz_1116 - HORIZONTAL	Power : DC 12V
EUT : Multimedia System	Note : 2DH5_2402MHz

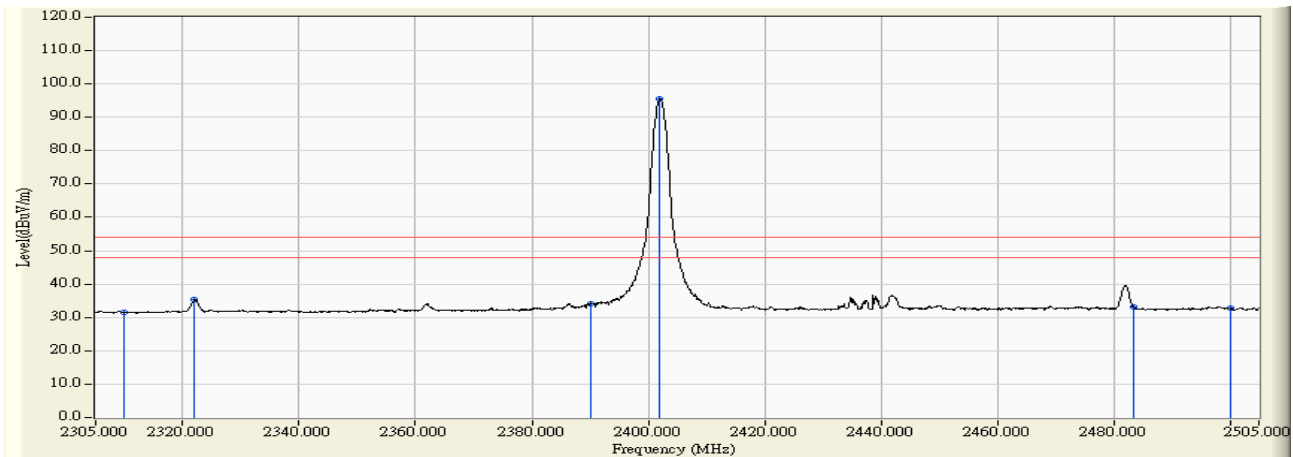

	Frequency (MHz)	Correct Factor (dB)	Reading Level (dBuV)	Measure Level (dBuV/m)	Margin (dB)	Limit (dBuV/m)	Detector Type
1	2310.000	13.428	18.103	31.531	-22.469	54.000	AVERAGE
2	2321.900	13.509	21.793	35.303	-18.697	54.000	AVERAGE
3	2390.000	13.977	20.149	34.126	-19.874	54.000	AVERAGE
4	* 2402.000	14.060	81.601	95.661	41.661	54.000	AVERAGE
5	2483.500	14.619	18.417	33.036	-20.964	54.000	AVERAGE
6	2500.000	14.728	17.949	32.677	-21.323	54.000	AVERAGE

Note:

1. All readings above 1GHz are performed with peak and/or average measurements as necessary.
2. Peak measurements: RBW = 1MHz, VBW = 1MHz, Sweep: Auto.
3. Average measurements: RBW = 1MHz, VBW = 10 Hz, Sweep: Auto.
4. “ * ”, means this data is the worst emission level.
5. Measurement Level = Reading Level + Correct Factor.
6. The average measurement was not performed when the peak measured data under the limit of average detection. If the readings given are average, peak measurement should also be supplied.

Site : CB4-H	Time : 2017/09/24
Limit : FCC_SpartC_15.209_03M_PK	Margin : 6
Probe : CB4-H_FCC_A115_EFS_1-18GHz_1116 - VERTICAL	Power : DC 12V
EUT : Multimedia System	Note : 2DH5_2402MHz

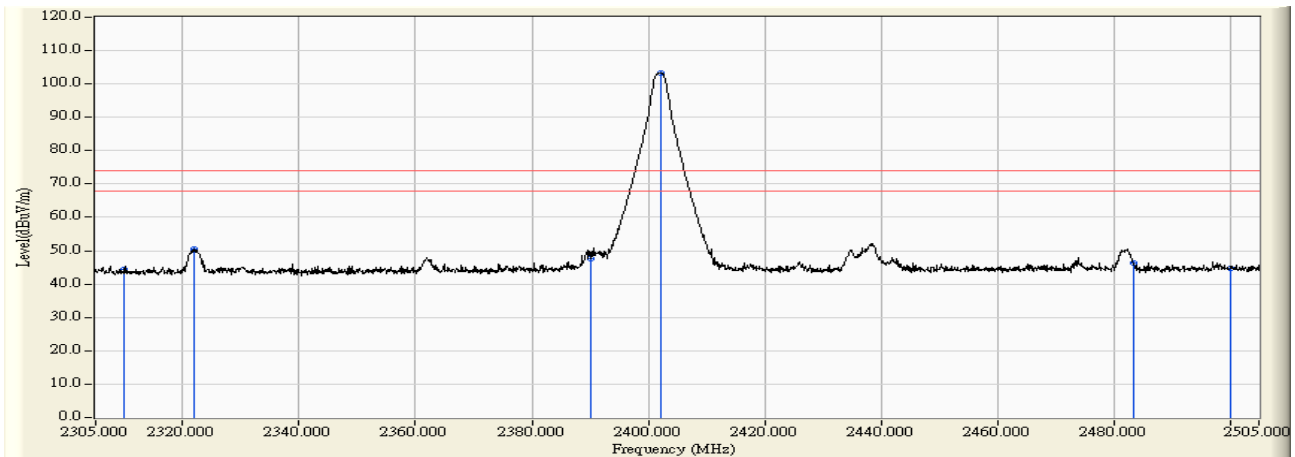

	Frequency (MHz)	Correct Factor (dB)	Reading Level (dBuV)	Measure Level (dBuV/m)	Margin (dB)	Limit (dBuV/m)	Detector Type
1	2310.000	13.428	31.037	44.465	-29.535	74.000	PEAK
2	2321.900	13.509	36.958	50.468	-23.532	74.000	PEAK
3	2390.000	13.977	33.507	47.484	-26.516	74.000	PEAK
4	* 2402.200	14.061	89.197	103.258	29.258	74.000	PEAK
5	2483.500	14.619	31.632	46.251	-27.749	74.000	PEAK
6	2500.000	14.728	29.907	44.635	-29.365	74.000	PEAK

Note:

1. All readings above 1GHz are performed with peak and/or average measurements as necessary.
2. Peak measurements: RBW = 1MHz, VBW = 1MHz, Sweep: Auto.
3. Average measurements: RBW = 1MHz, VBW = 10 Hz, Sweep: Auto.
4. “ * ”, means this data is the worst emission level.
5. Measurement Level = Reading Level + Correct Factor.
6. The average measurement was not performed when the peak measured data under the limit of average detection. If the readings given are average, peak measurement should also be supplied.

Site : CB4-H	Time : 2017/09/24
Limit : FCC_SpartC_15.209_03M_AV	Margin : 6
Probe : CB4-H_FCC_A115_EFS_1-18GHz_1116 - VERTICAL	Power : DC 12V
EUT : Multimedia System	Note : 2DH5_2402MHz

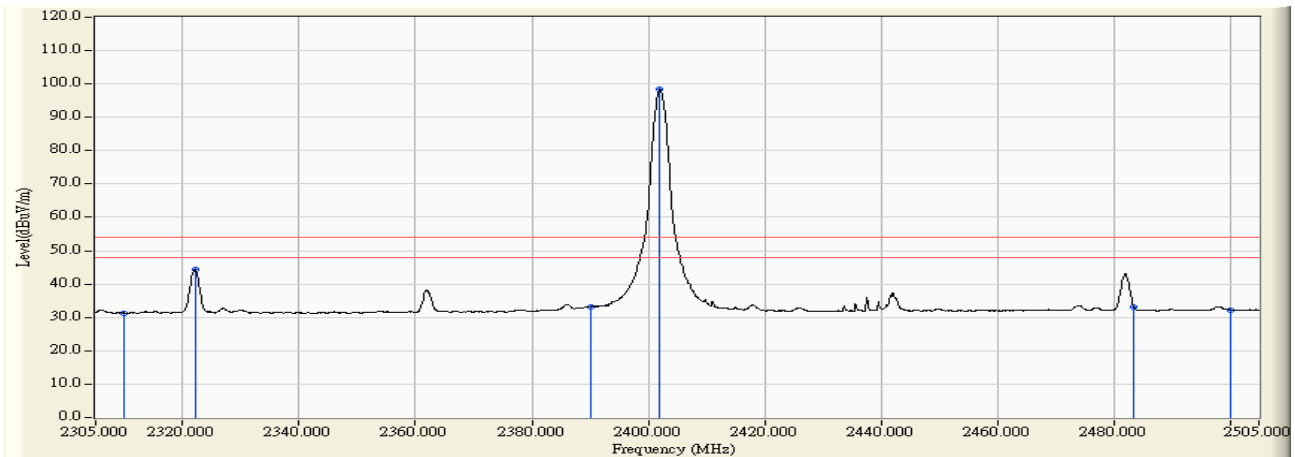

	Frequency (MHz)	Correct Factor (dB)	Reading Level (dBuV)	Measure Level (dBuV/m)	Margin (dB)	Limit (dBuV/m)	Detector Type
1	2310.000	13.428	17.864	31.292	-22.708	54.000	AVERAGE
2	2322.100	13.512	30.933	44.444	-9.556	54.000	AVERAGE
3	2390.000	13.977	19.248	33.225	-20.775	54.000	AVERAGE
4	* 2402.000	14.060	84.355	98.415	44.415	54.000	AVERAGE
5	2483.500	14.619	18.550	33.169	-20.831	54.000	AVERAGE
6	2500.000	14.728	17.598	32.326	-21.674	54.000	AVERAGE

Note:

1. All readings above 1GHz are performed with peak and/or average measurements as necessary.
2. Peak measurements: RBW = 1MHz, VBW = 1MHz, Sweep: Auto.
3. Average measurements: RBW = 1MHz, VBW = 10 Hz, Sweep: Auto.
4. “ * ”, means this data is the worst emission level.
5. Measurement Level = Reading Level + Correct Factor.
6. The average measurement was not performed when the peak measured data under the limit of average detection. If the readings given are average, peak measurement should also be supplied.

Site : CB4-H	Time : 2017/09/24
Limit : FCC_SpartC_15.209_03M_PK	Margin : 6
Probe : CB4-H_FCC_A115_EFS_1-18GHz_1116 - HORIZONTAL	Power : DC 12V
EUT : Multimedia System	Note : 2DH5_2441MHz

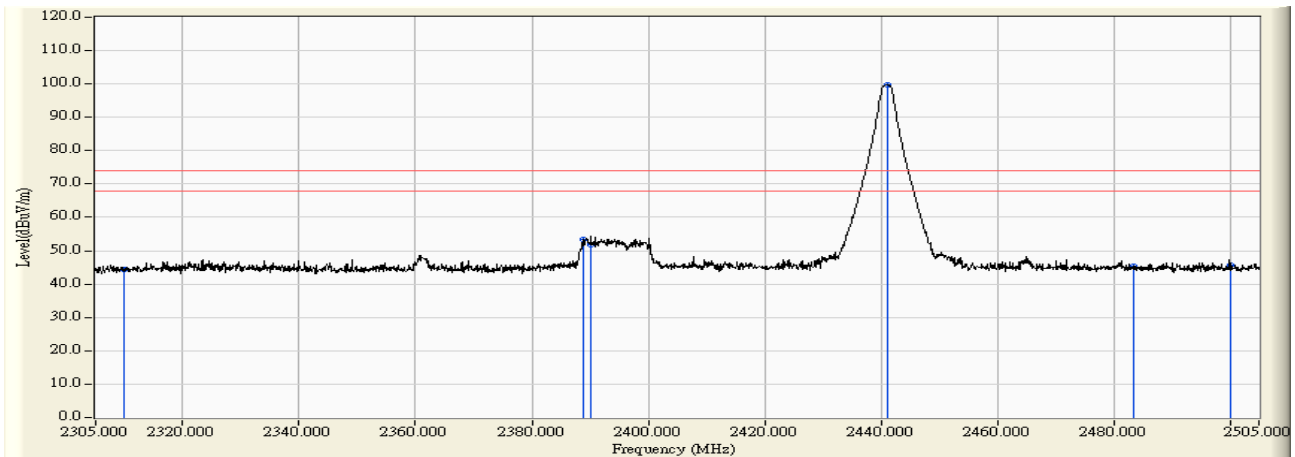

	Frequency (MHz)	Correct Factor (dB)	Reading Level (dBuV)	Measure Level (dBuV/m)	Margin (dB)	Limit (dBuV/m)	Detector Type
1	2310.000	13.428	31.070	44.498	-29.502	74.000	PEAK
2	2388.800	13.969	39.426	53.395	-20.605	74.000	PEAK
3	2390.000	13.977	37.888	51.865	-22.135	74.000	PEAK
4	* 2441.100	14.328	85.399	99.727	25.727	74.000	PEAK
5	2483.500	14.619	30.668	45.287	-28.713	74.000	PEAK
6	2500.000	14.728	31.084	45.812	-28.188	74.000	PEAK

Note:

1. All readings above 1GHz are performed with peak and/or average measurements as necessary.
2. Peak measurements: RBW = 1MHz, VBW = 1MHz, Sweep: Auto.
3. Average measurements: RBW = 1MHz, VBW = 10 Hz, Sweep: Auto.
4. “ * ”, means this data is the worst emission level.
5. Measurement Level = Reading Level + Correct Factor.
6. The average measurement was not performed when the peak measured data under the limit of average detection. If the readings given are average, peak measurement should also be supplied.

Site : CB4-H	Time : 2017/09/24
Limit : FCC_SpartC_15.209_03M_AV	Margin : 6
Probe : CB4-H_FCC_A115_EFS_1-18GHz_1116 - HORIZONTAL	Power : DC 12V
EUT : Multimedia System	Note : 2DH5_2441MHz

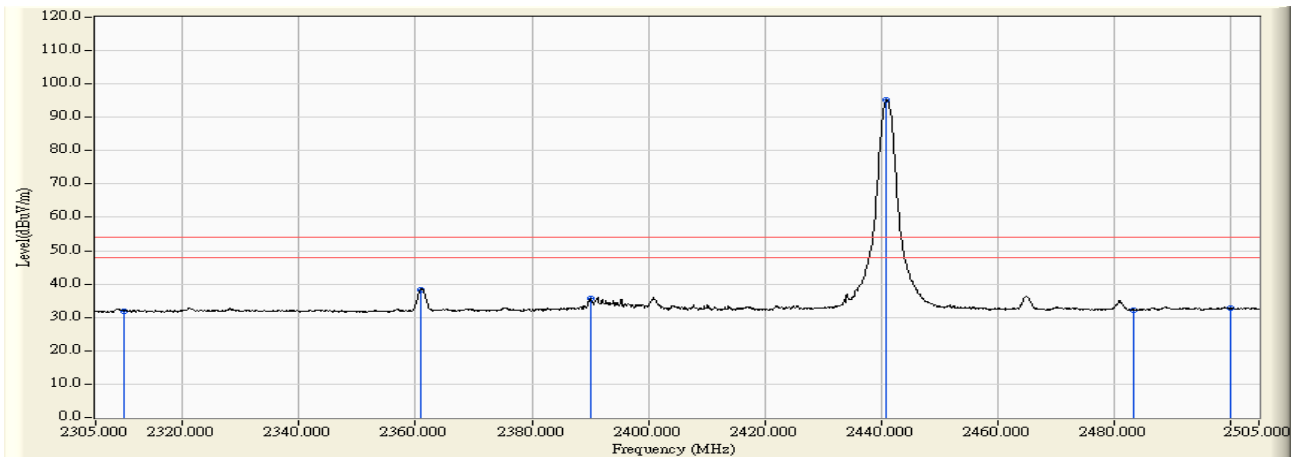

	Frequency (MHz)	Correct Factor (dB)	Reading Level (dBuV)	Measure Level (dBuV/m)	Margin (dB)	Limit (dBuV/m)	Detector Type
1	2310.000	13.428	18.487	31.915	-22.085	54.000	AVERAGE
2	2360.800	13.776	24.479	38.256	-15.744	54.000	AVERAGE
3	2390.000	13.977	21.785	35.762	-18.238	54.000	AVERAGE
4	* 2441.000	14.328	80.863	95.190	41.190	54.000	AVERAGE
5	2483.500	14.619	17.671	32.290	-21.710	54.000	AVERAGE
6	2500.000	14.728	18.003	32.731	-21.269	54.000	AVERAGE

Note:

1. All readings above 1GHz are performed with peak and/or average measurements as necessary.
2. Peak measurements: RBW = 1MHz, VBW = 1MHz, Sweep: Auto.
3. Average measurements: RBW = 1MHz, VBW = 10 Hz, Sweep: Auto.
4. “ * ”, means this data is the worst emission level.
5. Measurement Level = Reading Level + Correct Factor.
6. The average measurement was not performed when the peak measured data under the limit of average detection. If the readings given are average, peak measurement should also be supplied.

Site : CB4-H	Time : 2017/09/24
Limit : FCC_SpartC_15.209_03M_PK	Margin : 6
Probe : CB4-H_FCC_A115_EFS_1-18GHz_1116 - VERTICAL	Power : DC 12V
EUT : Multimedia System	Note : 2DH5_2441MHz

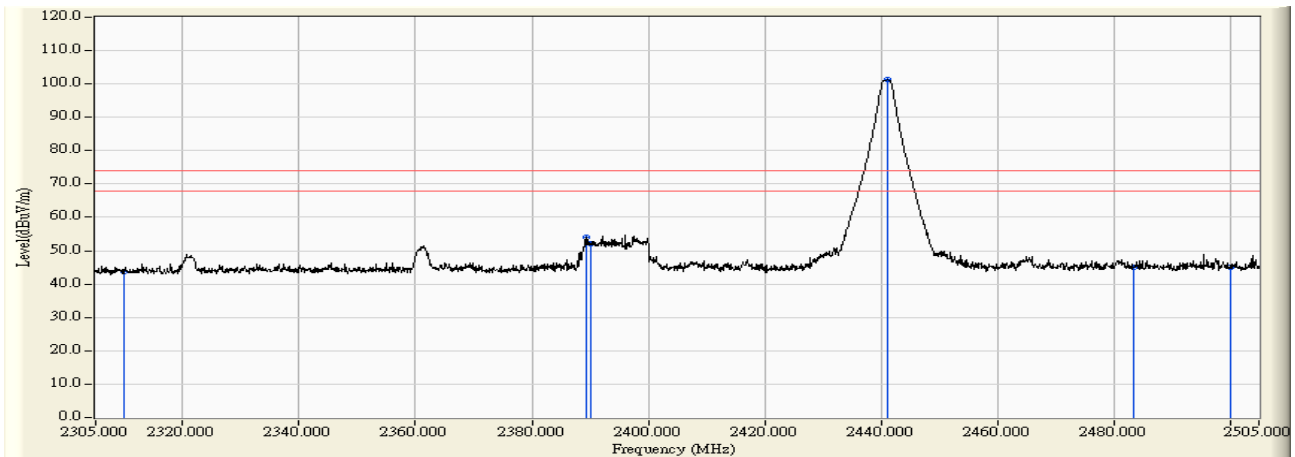

	Frequency (MHz)	Correct Factor (dB)	Reading Level (dBuV)	Measure Level (dBuV/m)	Margin (dB)	Limit (dBuV/m)	Detector Type
1	2310.000	13.428	30.273	43.701	-30.299	74.000	PEAK
2	2389.400	13.973	40.124	54.097	-19.903	74.000	PEAK
3	2390.000	13.977	38.236	52.213	-21.787	74.000	PEAK
4	* 2441.100	14.328	86.867	101.195	27.195	74.000	PEAK
5	2483.500	14.619	30.271	44.890	-29.110	74.000	PEAK
6	2500.000	14.728	30.298	45.026	-28.974	74.000	PEAK

Note:

1. All readings above 1GHz are performed with peak and/or average measurements as necessary.
2. Peak measurements: RBW = 1MHz, VBW = 1MHz, Sweep: Auto.
3. Average measurements: RBW = 1MHz, VBW = 10 Hz, Sweep: Auto.
4. “ * ”, means this data is the worst emission level.
5. Measurement Level = Reading Level + Correct Factor.
6. The average measurement was not performed when the peak measured data under the limit of average detection. If the readings given are average, peak measurement should also be supplied.

Site : CB4-H	Time : 2017/09/24
Limit : FCC_SpartC_15.209_03M_AV	Margin : 6
Probe : CB4-H_FCC_A115_EFS_1-18GHz_1116 - VERTICAL	Power : DC 12V
EUT : Multimedia System	Note : 2DH5_2441MHz

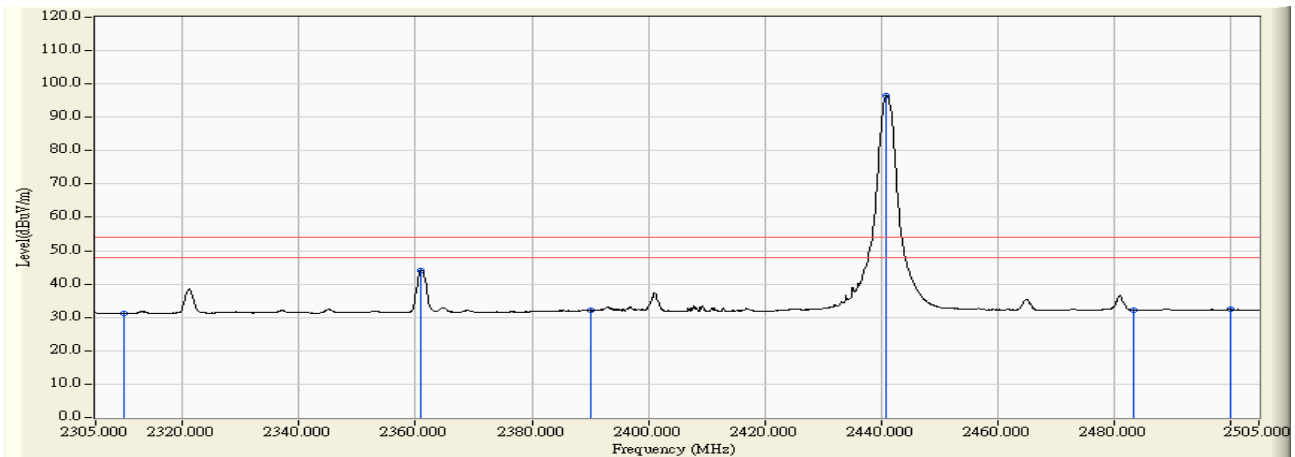

	Frequency (MHz)	Correct Factor (dB)	Reading Level (dBuV)	Measure Level (dBuV/m)	Margin (dB)	Limit (dBuV/m)	Detector Type
1	2310.000	13.428	17.727	31.155	-22.845	54.000	AVERAGE
2	2360.800	13.776	30.142	43.919	-10.081	54.000	AVERAGE
3	2390.000	13.977	18.156	32.133	-21.867	54.000	AVERAGE
4	* 2441.000	14.328	82.285	96.612	42.612	54.000	AVERAGE
5	2483.500	14.619	17.623	32.242	-21.758	54.000	AVERAGE
6	2500.000	14.728	17.610	32.338	-21.662	54.000	AVERAGE

Note:

1. All readings above 1GHz are performed with peak and/or average measurements as necessary.
2. Peak measurements: RBW = 1MHz, VBW = 1MHz, Sweep: Auto.
3. Average measurements: RBW = 1MHz, VBW = 10 Hz, Sweep: Auto.
4. “ * ”, means this data is the worst emission level.
5. Measurement Level = Reading Level + Correct Factor.
6. The average measurement was not performed when the peak measured data under the limit of average detection. If the readings given are average, peak measurement should also be supplied.

Site : CB4-H	Time : 2017/09/24
Limit : FCC_SpartC_15.209_03M_PK	Margin : 6
Probe : CB4-H_FCC_A115_EFS_1-18GHz_1116 - VERTICAL	Power : DC 12V
EUT : Multimedia System	Note : 2DH5_2480MHz

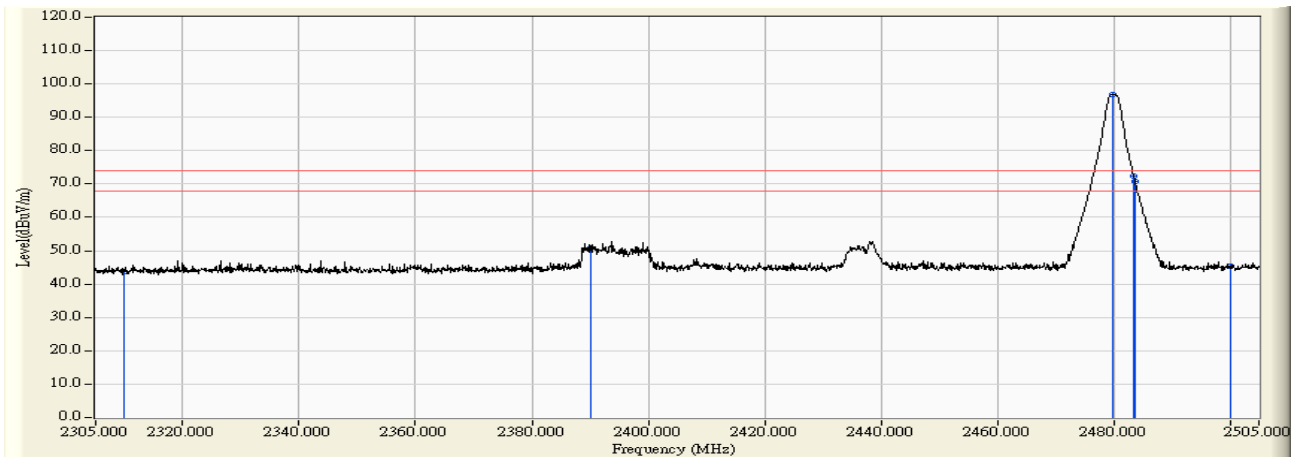

	Frequency (MHz)	Correct Factor (dB)	Reading Level (dBuV)	Measure Level (dBuV/m)	Margin (dB)	Limit (dBuV/m)	Detector Type
1	2310.000	13.428	30.485	43.913	-30.087	74.000	PEAK
2	2390.000	13.977	36.990	50.967	-23.033	74.000	PEAK
3	* 2479.800	14.594	82.303	96.896	22.896	74.000	PEAK
4	2483.500	14.619	57.760	72.379	-1.621	74.000	PEAK
5	2483.700	14.620	56.246	70.866	-3.134	74.000	PEAK
6	2500.000	14.728	30.787	45.515	-28.485	74.000	PEAK

Note:

1. All readings above 1GHz are performed with peak and/or average measurements as necessary.
2. Peak measurements: RBW = 1MHz, VBW = 1MHz, Sweep: Auto.
3. Average measurements: RBW = 1MHz, VBW = 10 Hz, Sweep: Auto.
4. “ * ”, means this data is the worst emission level.
5. Measurement Level = Reading Level + Correct Factor.
6. The average measurement was not performed when the peak measured data under the limit of average detection. If the readings given are average, peak measurement should also be supplied.

Site : CB4-H	Time : 2017/09/24
Limit : FCC_SpartC_15.209_03M_AV	Margin : 6
Probe : CB4-H_FCC_A115_EFS_1-18GHz_1116 - VERTICAL	Power : DC 12V
EUT : Multimedia System	Note : 2DH5_2480MHz

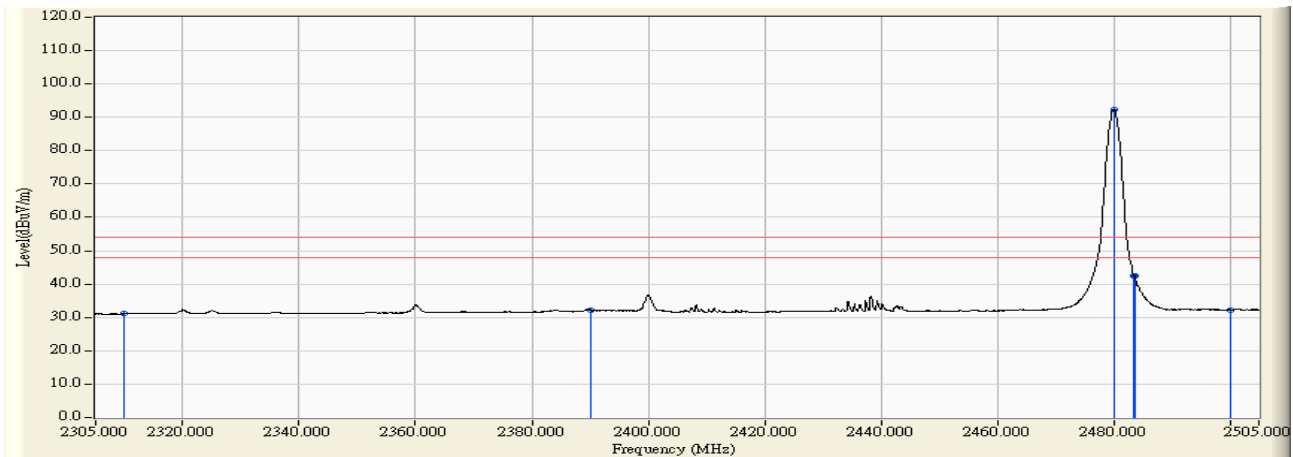

	Frequency (MHz)	Correct Factor (dB)	Reading Level (dBuV)	Measure Level (dBuV/m)	Margin (dB)	Limit (dBuV/m)	Detector Type
1	2310.000	13.428	17.663	31.091	-22.909	54.000	AVERAGE
2	2390.000	13.977	18.166	32.143	-21.857	54.000	AVERAGE
3	* 2480.100	14.595	77.849	92.445	38.445	54.000	AVERAGE
4	2483.500	14.619	27.983	42.602	-11.398	54.000	AVERAGE
5	2483.600	14.619	27.802	42.422	-11.578	54.000	AVERAGE
6	2500.000	14.728	17.523	32.251	-21.749	54.000	AVERAGE

Note:

1. All readings above 1GHz are performed with peak and/or average measurements as necessary.
2. Peak measurements: RBW = 1MHz, VBW = 1MHz, Sweep: Auto.
3. Average measurements: RBW = 1MHz, VBW = 10 Hz, Sweep: Auto.
4. “ * ”, means this data is the worst emission level.
5. Measurement Level = Reading Level + Correct Factor.
6. The average measurement was not performed when the peak measured data under the limit of average detection. If the readings given are average, peak measurement should also be supplied.

Site : CB4-H	Time : 2017/09/24
Limit : FCC_SpartC_15.209_03M_PK	Margin : 6
Probe : CB4-H_FCC_A115_EFS_1-18GHz_1116 - HORIZONTAL	Power : DC 12V
EUT : Multimedia System	Note : 2DH5_2480MHz

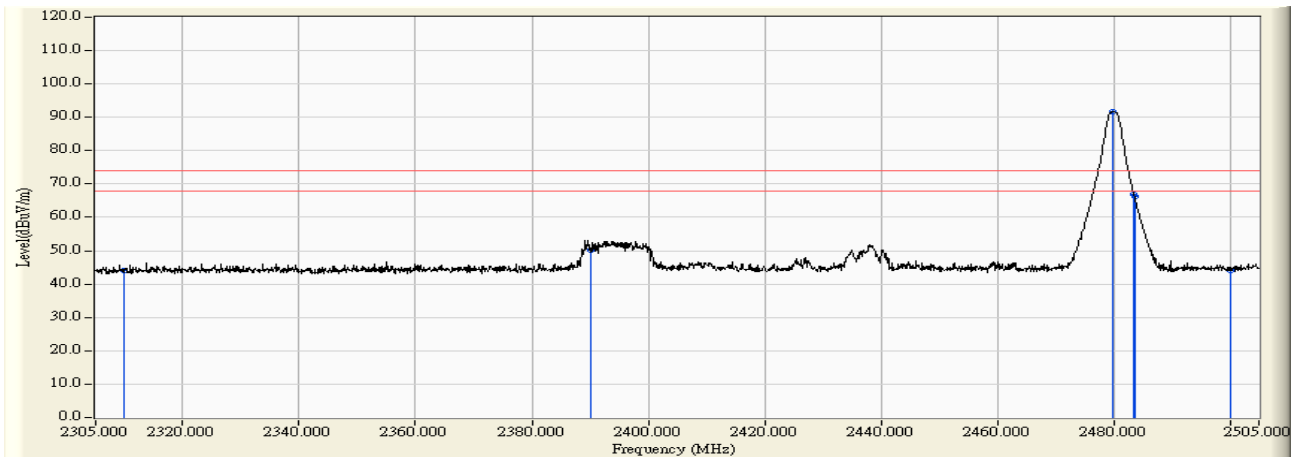

	Frequency (MHz)	Correct Factor (dB)	Reading Level (dBuV)	Measure Level (dBuV/m)	Margin (dB)	Limit (dBuV/m)	Detector Type
1	2310.000	13.428	30.663	44.091	-29.909	74.000	PEAK
2	2390.000	13.977	36.186	50.163	-23.837	74.000	PEAK
3	* 2479.800	14.594	77.087	91.680	17.680	74.000	PEAK
4	2483.500	14.619	52.321	66.940	-7.060	74.000	PEAK
5	2483.600	14.619	51.538	66.158	-7.842	74.000	PEAK
6	2500.000	14.728	29.451	44.179	-29.821	74.000	PEAK

Note:

1. All readings above 1GHz are performed with peak and/or average measurements as necessary.
2. Peak measurements: RBW = 1MHz, VBW = 1MHz, Sweep: Auto.
3. Average measurements: RBW = 1MHz, VBW = 10 Hz, Sweep: Auto.
4. “ * ”, means this data is the worst emission level.
5. Measurement Level = Reading Level + Correct Factor.
6. The average measurement was not performed when the peak measured data under the limit of average detection. If the readings given are average, peak measurement should also be supplied.

Site : CB4-H	Time : 2017/09/24
Limit : FCC_SpartC_15.209_03M_AV	Margin : 6
Probe : CB4-H_FCC_A115_EFS_1-18GHz_1116 - HORIZONTAL	Power : DC 12V
EUT : Multimedia System	Note : 2DH5_2480MHz

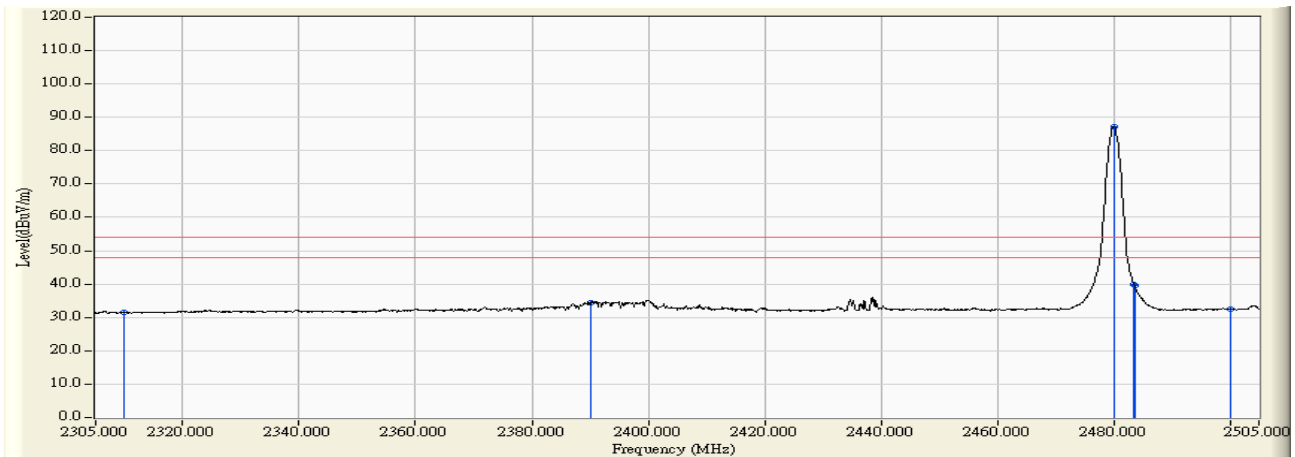

	Frequency (MHz)	Correct Factor (dB)	Reading Level (dBuV)	Measure Level (dBuV/m)	Margin (dB)	Limit (dBuV/m)	Detector Type
1	2310.000	13.428	18.083	31.511	-22.489	54.000	AVERAGE
2	2390.000	13.977	20.550	34.527	-19.473	54.000	AVERAGE
3	* 2480.000	14.595	72.732	87.327	33.327	54.000	AVERAGE
4	2483.500	14.619	25.336	39.955	-14.045	54.000	AVERAGE
5	2483.600	14.619	24.812	39.432	-14.568	54.000	AVERAGE
6	2500.000	14.728	17.635	32.363	-21.637	54.000	AVERAGE

Note:

1. All readings above 1GHz are performed with peak and/or average measurements as necessary.
2. Peak measurements: RBW = 1MHz, VBW = 1MHz, Sweep: Auto.
3. Average measurements: RBW = 1MHz, VBW = 10 Hz, Sweep: Auto.
4. “ * ”, means this data is the worst emission level.
5. Measurement Level = Reading Level + Correct Factor.
6. The average measurement was not performed when the peak measured data under the limit of average detection. If the readings given are average, peak measurement should also be supplied.

Site : CB4-H	Time : 2017/09/24
Limit : FCC_SpartC_15.209_03M_PK	Margin : 6
Probe : CB4-H_FCC_A115_EFS_1-18GHz_1116 - HORIZONTAL	Power : DC 12V
EUT : Multimedia System	Note : 3DH5_2402MHz

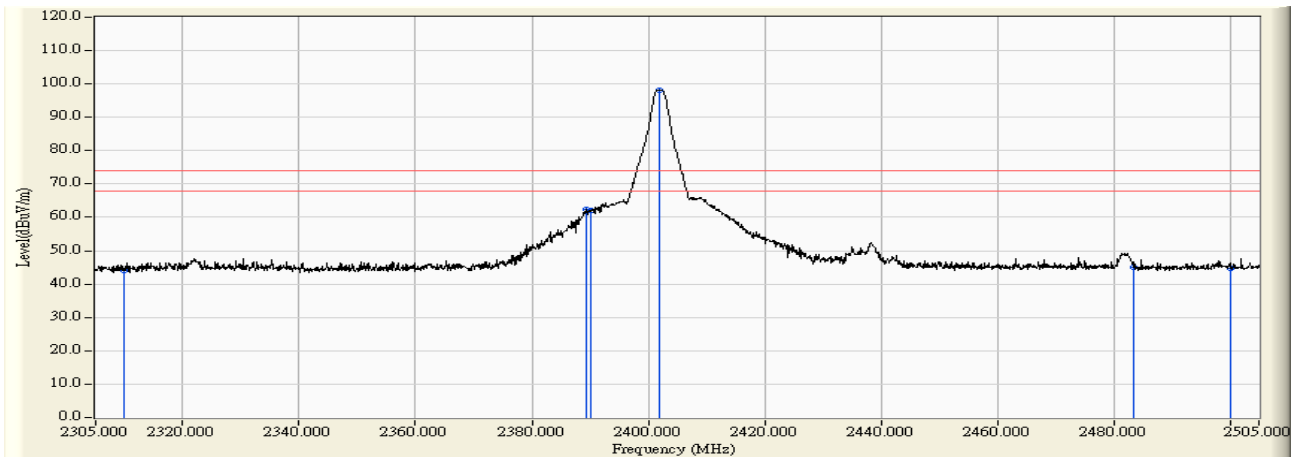

	Frequency (MHz)	Correct Factor (dB)	Reading Level (dBuV)	Measure Level (dBuV/m)	Margin (dB)	Limit (dBuV/m)	Detector Type
1	2310.000	13.428	30.714	44.142	-29.858	74.000	PEAK
2	2389.300	13.972	48.520	62.492	-11.508	74.000	PEAK
3	2390.000	13.977	48.121	62.098	-11.902	74.000	PEAK
4	* 2401.900	14.059	84.189	98.248	24.248	74.000	PEAK
5	2483.500	14.619	30.501	45.120	-28.880	74.000	PEAK
6	2500.000	14.728	29.911	44.639	-29.361	74.000	PEAK

Note:

1. All readings above 1GHz are performed with peak and/or average measurements as necessary.
2. Peak measurements: RBW = 1MHz, VBW = 1MHz, Sweep: Auto.
3. Average measurements: RBW = 1MHz, VBW = 10 Hz, Sweep: Auto.
4. “ * ”, means this data is the worst emission level.
5. Measurement Level = Reading Level + Correct Factor.
6. The average measurement was not performed when the peak measured data under the limit of average detection. If the readings given are average, peak measurement should also be supplied.

Site : CB4-H	Time : 2017/09/24
Limit : FCC_SpartC_15.209_03M_AV	Margin : 6
Probe : CB4-H_FCC_A115_EFS_1-18GHz_1116 - HORIZONTAL	Power : DC 12V
EUT : Multimedia System	Note : 3DH5_2402MHz

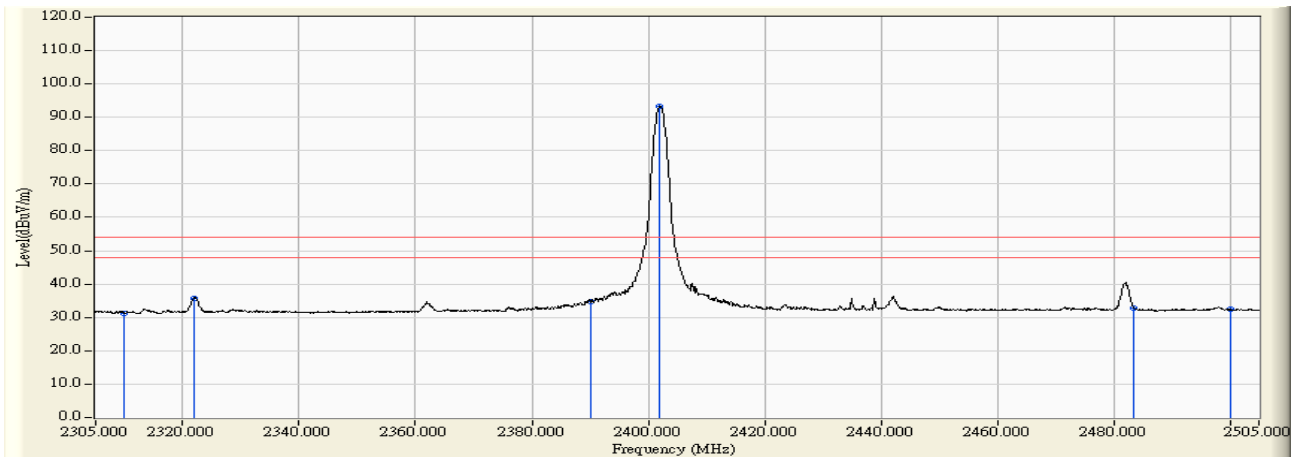

	Frequency (MHz)	Correct Factor (dB)	Reading Level (dBuV)	Measure Level (dBuV/m)	Margin (dB)	Limit (dBuV/m)	Detector Type
1	2310.000	13.428	17.884	31.312	-22.688	54.000	AVERAGE
2	2321.900	13.509	22.304	35.814	-18.186	54.000	AVERAGE
3	2390.000	13.977	20.679	34.656	-19.344	54.000	AVERAGE
4	* 2402.000	14.060	79.396	93.456	19.456	74.000	AVERAGE
5	2483.500	14.619	18.221	32.840	-21.160	54.000	AVERAGE
6	2500.000	14.728	17.814	32.542	-21.458	54.000	AVERAGE

Note:

1. All readings above 1GHz are performed with peak and/or average measurements as necessary.
2. Peak measurements: RBW = 1MHz, VBW = 1MHz, Sweep: Auto.
3. Average measurements: RBW = 1MHz, VBW = 10 Hz, Sweep: Auto.
4. “ * ”, means this data is the worst emission level.
5. Measurement Level = Reading Level + Correct Factor.
6. The average measurement was not performed when the peak measured data under the limit of average detection. If the readings given are average, peak measurement should also be supplied.

Site : CB4-H	Time : 2017/09/24
Limit : FCC_SpartC_15.209_03M_PK	Margin : 6
Probe : CB4-H_FCC_A115_EFS_1-18GHz_1116 - VERTICAL	Power : DC 12V
EUT : Multimedia System	Note : 3DH5_2402MHz

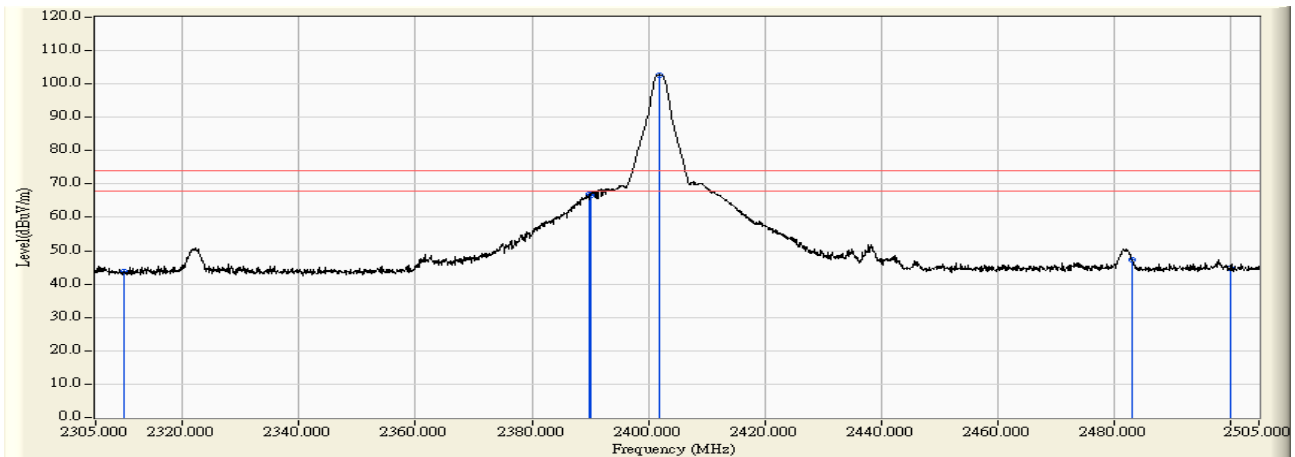

	Frequency (MHz)	Correct Factor (dB)	Reading Level (dBuV)	Measure Level (dBuV/m)	Margin (dB)	Limit (dBuV/m)	Detector Type
1	2310.000	13.428	30.241	43.669	-30.331	74.000	PEAK
2	2389.900	13.977	52.797	66.773	-7.227	74.000	PEAK
3	2390.000	13.977	52.745	66.722	-7.278	74.000	PEAK
4	* 2402.000	14.060	88.728	102.788	28.788	74.000	PEAK
5	2483.250	14.618	32.646	47.263	-26.737	74.000	PEAK
6	2500.000	14.728	30.101	44.829	-29.171	74.000	PEAK

Note:

1. All readings above 1GHz are performed with peak and/or average measurements as necessary.
2. Peak measurements: RBW = 1MHz, VBW = 1MHz, Sweep: Auto.
3. Average measurements: RBW = 1MHz, VBW = 10 Hz, Sweep: Auto.
4. “ * ”, means this data is the worst emission level.
5. Measurement Level = Reading Level + Correct Factor.
6. The average measurement was not performed when the peak measured data under the limit of average detection. If the readings given are average, peak measurement should also be supplied.

Site : CB4-H	Time : 2017/09/24
Limit : FCC_SpartC_15.209_03M_AV	Margin : 6
Probe : CB4-H_FCC_A115_EFS_1-18GHz_1116 - VERTICAL	Power : DC 12V
EUT : Multimedia System	Note : 3DH5_2402MHz

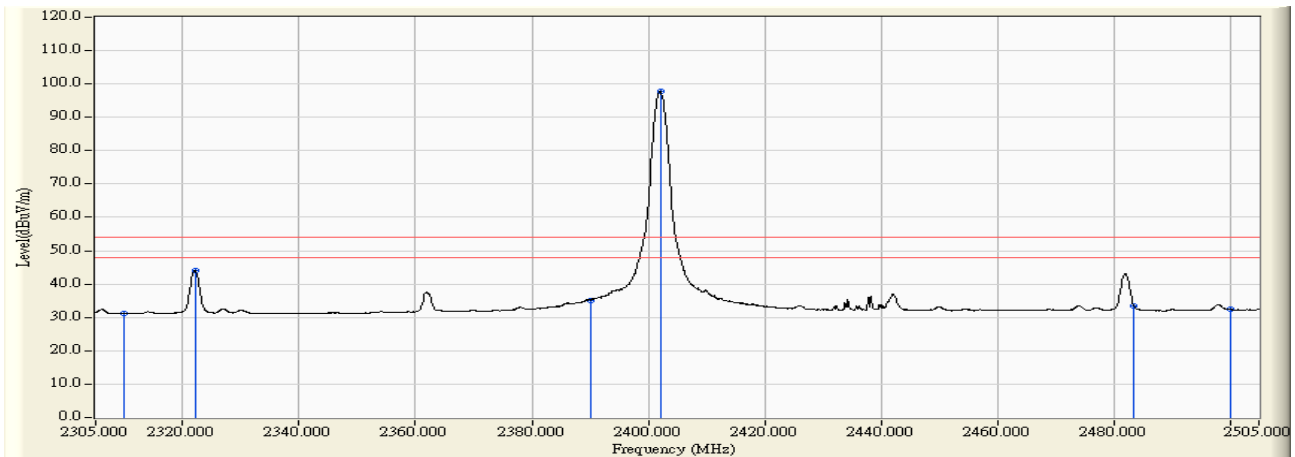

	Frequency (MHz)	Correct Factor (dB)	Reading Level (dBuV)	Measure Level (dBuV/m)	Margin (dB)	Limit (dBuV/m)	Detector Type
1	2310.000	13.428	17.745	31.173	-22.827	54.000	AVERAGE
2	2322.100	13.512	30.590	44.101	-9.899	54.000	AVERAGE
3	2390.000	13.977	21.125	35.102	-18.898	54.000	AVERAGE
4	* 2402.100	14.061	83.788	97.848	43.848	54.000	AVERAGE
5	2483.500	14.619	18.710	33.329	-20.671	54.000	AVERAGE
6	2500.000	14.728	17.607	32.335	-21.665	54.000	AVERAGE

Note:

1. All readings above 1GHz are performed with peak and/or average measurements as necessary.
2. Peak measurements: RBW = 1MHz, VBW = 1MHz, Sweep: Auto.
3. Average measurements: RBW = 1MHz, VBW = 10 Hz, Sweep: Auto.
4. “ * ”, means this data is the worst emission level.
5. Measurement Level = Reading Level + Correct Factor.
6. The average measurement was not performed when the peak measured data under the limit of average detection. If the readings given are average, peak measurement should also be supplied.

Site : CB4-H	Time : 2017/09/24
Limit : FCC_SpartC_15.209_03M_PK	Margin : 6
Probe : CB4-H_FCC_A115_EFS_1-18GHz_1116 - HORIZONTAL	Power : DC 12V
EUT : Multimedia System	Note : 3DH5_2441MHz

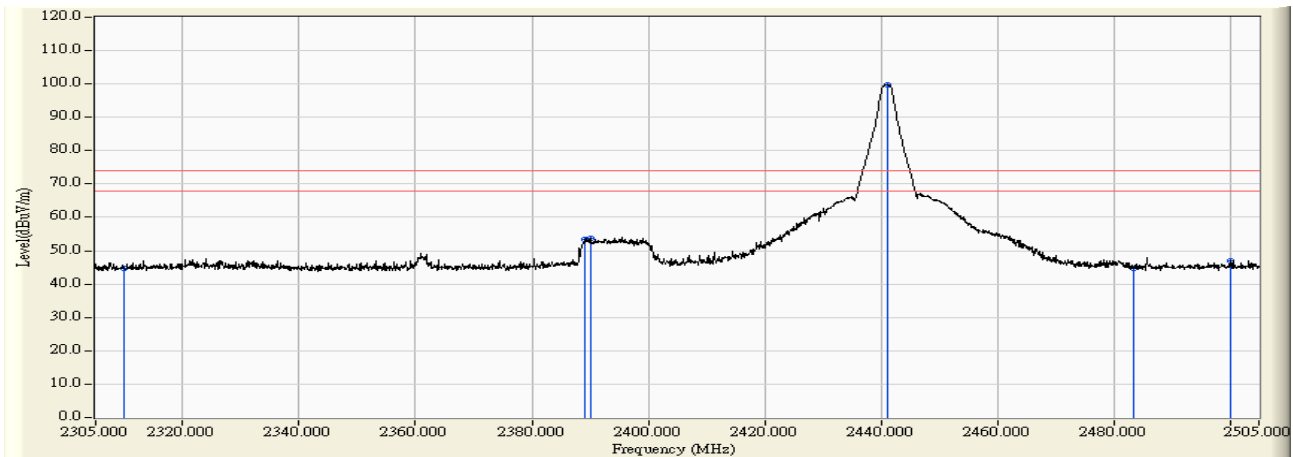

	Frequency (MHz)	Correct Factor (dB)	Reading Level (dBuV)	Measure Level (dBuV/m)	Margin (dB)	Limit (dBuV/m)	Detector Type
1	2310.000	13.428	31.133	44.561	-29.439	74.000	PEAK
2	2389.100	13.971	39.300	53.271	-20.729	74.000	PEAK
3	2390.000	13.977	39.870	53.847	-20.153	74.000	PEAK
4	* 2441.200	14.328	85.368	99.697	25.697	74.000	PEAK
5	2483.500	14.619	30.140	44.759	-29.241	74.000	PEAK
6	2500.000	14.728	32.212	46.940	-27.060	74.000	PEAK

Note:

1. All readings above 1GHz are performed with peak and/or average measurements as necessary.
2. Peak measurements: RBW = 1MHz, VBW = 1MHz, Sweep: Auto.
3. Average measurements: RBW = 1MHz, VBW = 10 Hz, Sweep: Auto.
4. “ * ”, means this data is the worst emission level.
5. Measurement Level = Reading Level + Correct Factor.
6. The average measurement was not performed when the peak measured data under the limit of average detection. If the readings given are average, peak measurement should also be supplied.

Site : CB4-H	Time : 2017/09/24
Limit : FCC_SpartC_15.209_03M_PK	Margin : 6
Probe : CB4-H_FCC_A115_EFS_1-18GHz_1116 - HORIZONTAL	Power : DC 12V
EUT : Multimedia System	Note : 3DH5_2441MHz

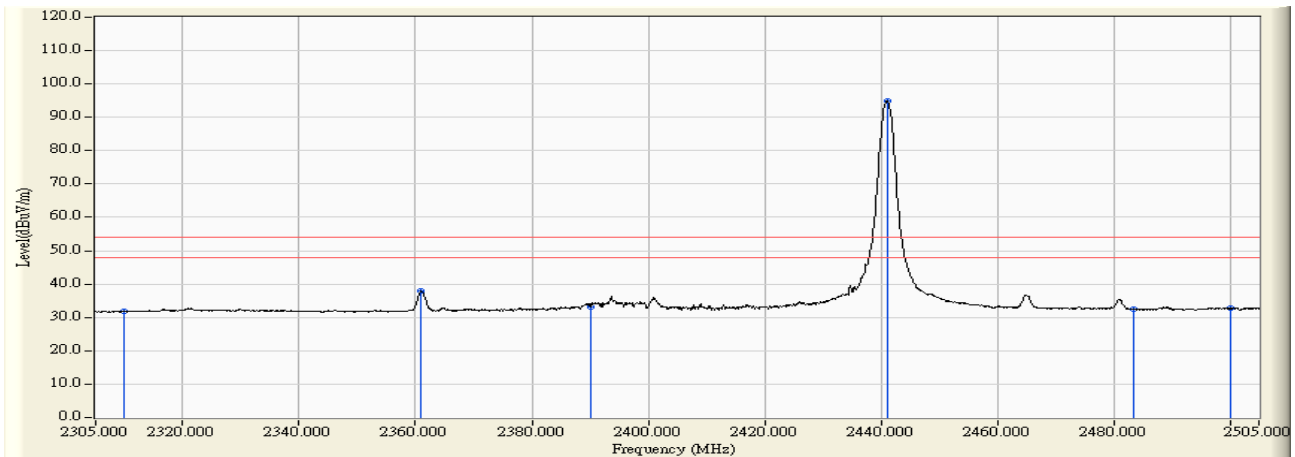

	Frequency (MHz)	Correct Factor (dB)	Reading Level (dBuV)	Measure Level (dBuV/m)	Margin (dB)	Limit (dBuV/m)	Detector Type
1	2310.000	13.428	18.358	31.786	-22.214	54.000	AVERAGE
2	2361.000	13.779	24.065	37.843	-16.157	54.000	AVERAGE
3	2390.000	13.977	19.053	33.030	-20.970	54.000	AVERAGE
4	* 2441.100	14.328	80.454	94.782	40.782	54.000	AVERAGE
5	2483.500	14.619	17.802	32.421	-21.579	54.000	AVERAGE
6	2500.000	14.728	17.970	32.698	-21.302	54.000	AVERAGE

Note:

1. All readings above 1GHz are performed with peak and/or average measurements as necessary.
2. Peak measurements: RBW = 1MHz, VBW = 1MHz, Sweep: Auto.
3. Average measurements: RBW = 1MHz, VBW = 10 Hz, Sweep: Auto.
4. “ * ”, means this data is the worst emission level.
5. Measurement Level = Reading Level + Correct Factor.
6. The average measurement was not performed when the peak measured data under the limit of average detection. If the readings given are average, peak measurement should also be supplied.

Site : CB4-H	Time : 2017/09/24
Limit : FCC_SpartC_15.209_03M_PK	Margin : 6
Probe : CB4-H_FCC_A115_EFS_1-18GHz_1116 - VERTICAL	Power : DC 12V
EUT : Multimedia System	Note : 3DH5_2441MHz

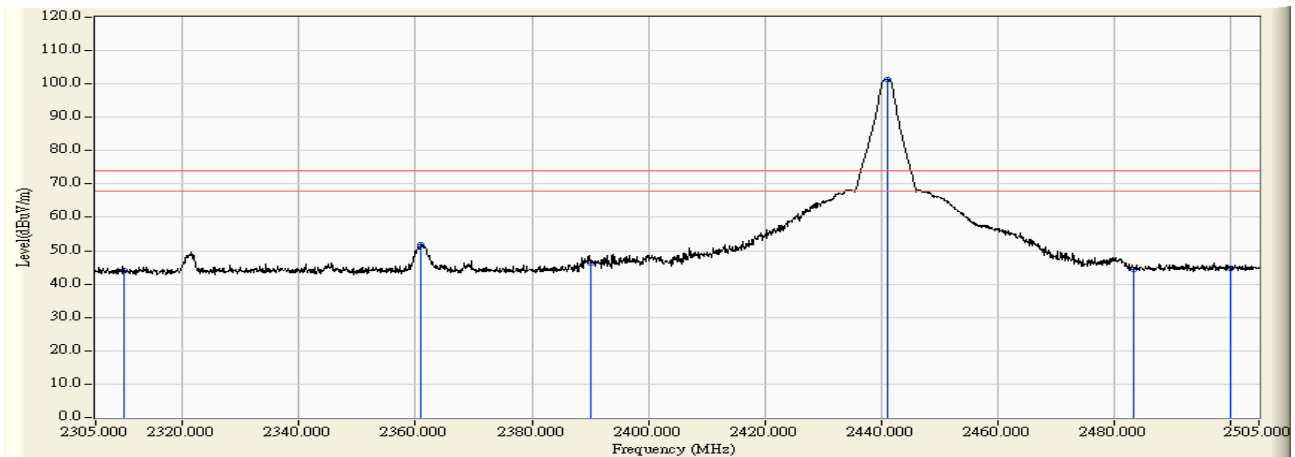

	Frequency (MHz)	Correct Factor (dB)	Reading Level (dBuV)	Measure Level (dBuV/m)	Margin (dB)	Limit (dBuV/m)	Detector Type
1	2310.000	13.428	30.589	44.017	-29.983	74.000	PEAK
2	2361.000	13.779	38.037	51.815	-22.185	74.000	PEAK
3	2390.000	13.977	32.212	46.189	-27.811	74.000	PEAK
4	* 2441.100	14.328	86.966	101.294	27.294	74.000	PEAK
5	2483.500	14.619	29.904	44.523	-29.477	74.000	PEAK
6	2500.000	14.728	30.007	44.735	-29.265	74.000	PEAK

Note:

1. All readings above 1GHz are performed with peak and/or average measurements as necessary.
2. Peak measurements: RBW = 1MHz, VBW = 1MHz, Sweep: Auto.
3. Average measurements: RBW = 1MHz, VBW = 10 Hz, Sweep: Auto.
4. “ * ”, means this data is the worst emission level.
5. Measurement Level = Reading Level + Correct Factor.
6. The average measurement was not performed when the peak measured data under the limit of average detection. If the readings given are average, peak measurement should also be supplied.

Site : CB4-H	Time : 2017/09/24
Limit : FCC_SpartC_15.209_03M_AV	Margin : 6
Probe : CB4-H_FCC_A115_EFS_1-18GHz_1116 - VERTICAL	Power : DC 12V
EUT : Multimedia System	Note : 3DH5_2441MHz

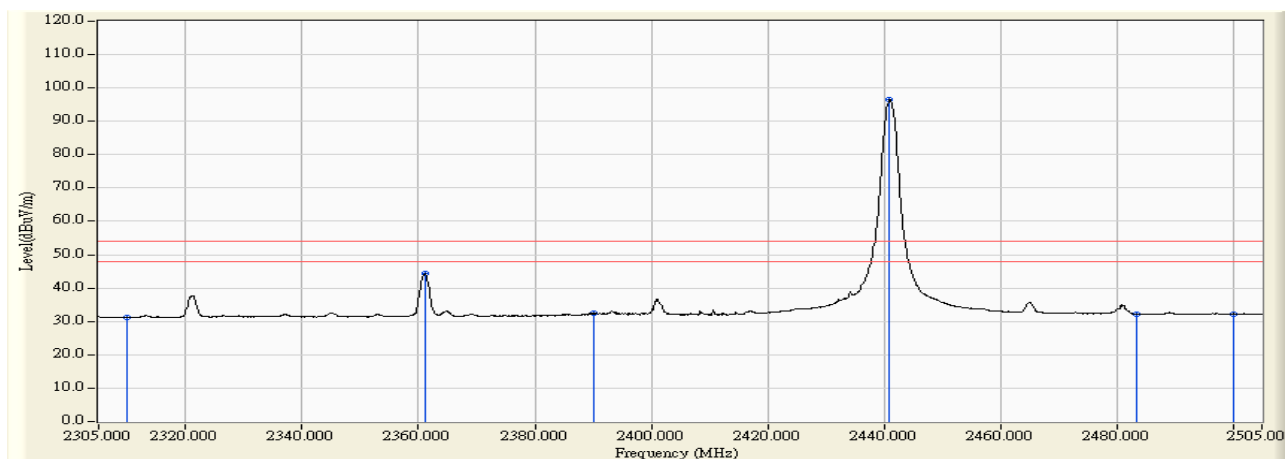

	Frequency (MHz)	Correct Factor (dB)	Reading Level (dBuV)	Measure Level (dBuV/m)	Margin (dB)	Limit (dBuV/m)	Detector Type
1	2310.000	13.428	17.765	31.193	-22.807	54.000	AVERAGE
2	2361.100	13.779	30.475	44.254	-9.746	54.000	AVERAGE
3	2390.000	13.977	18.362	32.339	-21.661	54.000	AVERAGE
4	* 2441.000	14.328	82.097	96.424	42.424	54.000	AVERAGE
5	2483.500	14.619	17.562	32.181	-21.819	54.000	AVERAGE
6	2500.000	14.728	17.579	32.307	-21.693	54.000	AVERAGE

Note:

1. All readings above 1GHz are performed with peak and/or average measurements as necessary.
2. Peak measurements: RBW = 1MHz, VBW = 1MHz, Sweep: Auto.
3. Average measurements: RBW = 1MHz, VBW = 10 Hz, Sweep: Auto.
4. “ * ”, means this data is the worst emission level.
5. Measurement Level = Reading Level + Correct Factor.
6. The average measurement was not performed when the peak measured data under the limit of average detection. If the readings given are average, peak measurement should also be supplied.

Site : CB4-H	Time : 2017/09/24
Limit : FCC_SpartC_15.209_03M_PK	Margin : 6
Probe : CB4-H_FCC_A115_EFS_1-18GHz_1116 - HORIZONTAL	Power : DC 12V
EUT : Multimedia System	Note : 3DH5_2480MHz

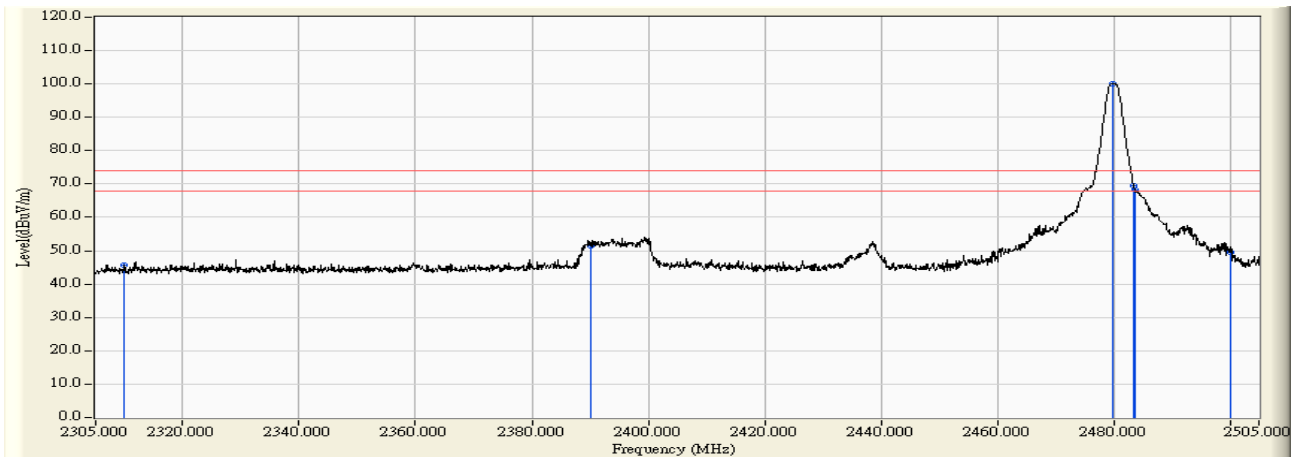

	Frequency (MHz)	Correct Factor (dB)	Reading Level (dBuV)	Measure Level (dBuV/m)	Margin (dB)	Limit (dBuV/m)	Detector Type
1	2310.000	13.428	32.110	45.538	-28.462	74.000	PEAK
2	2390.000	13.977	37.504	51.481	-22.519	74.000	PEAK
3	* 2479.900	14.595	85.470	100.064	26.064	74.000	PEAK
4	2483.500	14.619	54.852	69.471	-4.529	74.000	PEAK
5	2483.600	14.619	53.602	68.222	-5.778	74.000	PEAK
6	2500.000	14.728	34.976	49.704	-24.296	74.000	PEAK

Note:

1. All readings above 1GHz are performed with peak and/or average measurements as necessary.
2. Peak measurements: RBW = 1MHz, VBW = 1MHz, Sweep: Auto.
3. Average measurements: RBW = 1MHz, VBW = 10 Hz, Sweep: Auto.
4. “ * ”, means this data is the worst emission level.
5. Measurement Level = Reading Level + Correct Factor.
6. The average measurement was not performed when the peak measured data under the limit of average detection. If the readings given are average, peak measurement should also be supplied.

Site : CB4-H	Time : 2017/09/24
Limit : FCC_SpartC_15.209_03M_AV	Margin : 6
Probe : CB4-H_FCC_A115_EFS_1-18GHz_1116 - HORIZONTAL	Power : DC 12V
EUT : Multimedia System	Note : 3DH5_2480MHz

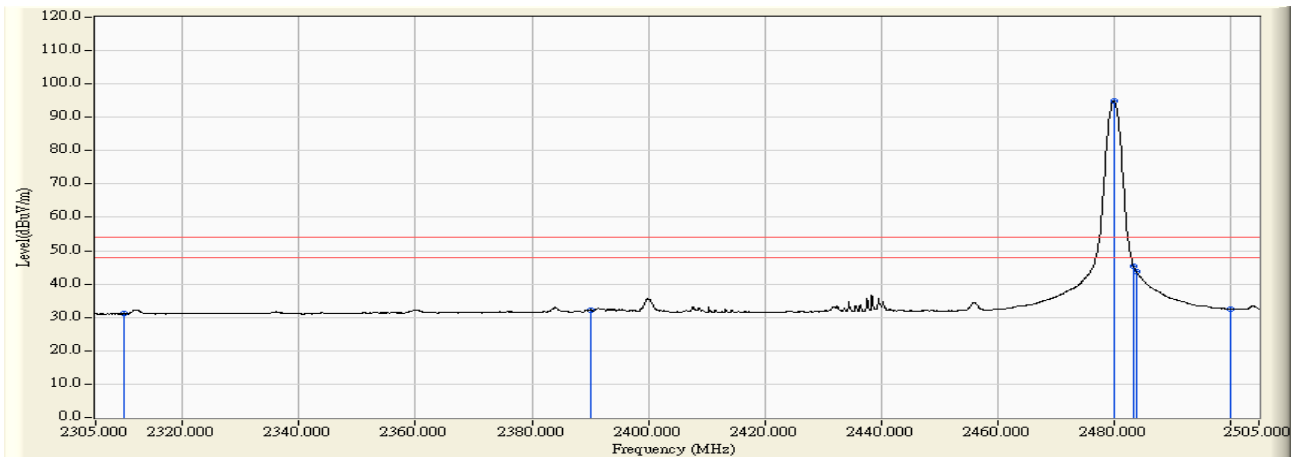

	Frequency (MHz)	Correct Factor (dB)	Reading Level (dBuV)	Measure Level (dBuV/m)	Margin (dB)	Limit (dBuV/m)	Detector Type
1	2310.000	13.428	17.654	31.082	-22.918	54.000	AVERAGE
2	2390.000	13.977	18.321	32.298	-21.702	54.000	AVERAGE
3	* 2480.000	14.595	80.405	95.000	41.000	54.000	AVERAGE
4	2483.500	14.619	30.588	45.207	-8.793	54.000	AVERAGE
5	2483.900	14.622	29.227	43.849	-10.151	54.000	AVERAGE
6	2500.000	14.728	17.795	32.523	-21.477	54.000	AVERAGE

Note:

1. All readings above 1GHz are performed with peak and/or average measurements as necessary.
2. Peak measurements: RBW = 1MHz, VBW = 1MHz, Sweep: Auto.
3. Average measurements: RBW = 1MHz, VBW = 10 Hz, Sweep: Auto.
4. “ * ”, means this data is the worst emission level.
5. Measurement Level = Reading Level + Correct Factor.
6. The average measurement was not performed when the peak measured data under the limit of average detection. If the readings given are average, peak measurement should also be supplied.

Site : CB4-H	Time : 2017/09/24
Limit : FCC_SpartC_15.209_03M_PK	Margin : 6
Probe : CB4-H_FCC_A115_EFS_1-18GHz_1116 - VERTICAL	Power : DC 12V
EUT : Multimedia System	Note : 3DH5_2480MHz

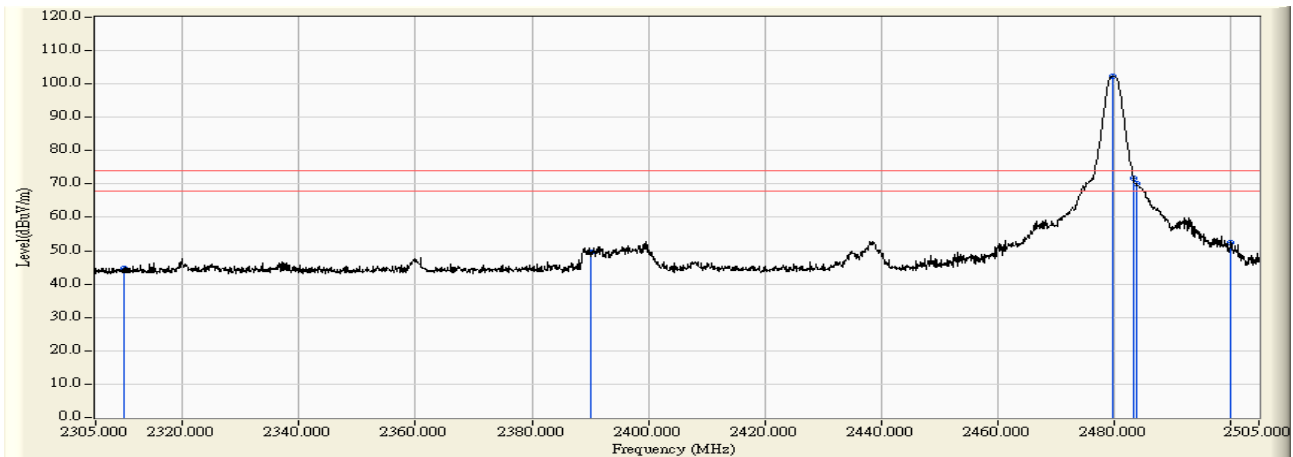

	Frequency (MHz)	Correct Factor (dB)	Reading Level (dBuV)	Measure Level (dBuV/m)	Margin (dB)	Limit (dBuV/m)	Detector Type
1	2310.000	13.428	31.211	44.639	-29.361	74.000	PEAK
2	2390.000	13.977	35.592	49.569	-24.431	74.000	PEAK
3	* 2479.800	14.594	87.594	102.187	28.187	74.000	PEAK
4	2483.500	14.619	57.208	71.827	-2.173	74.000	PEAK
5	2483.900	14.622	55.483	70.105	-3.895	74.000	PEAK
6	2500.000	14.728	37.632	52.360	-21.640	74.000	PEAK

Note:

1. All readings above 1GHz are performed with peak and/or average measurements as necessary.
2. Peak measurements: RBW = 1MHz, VBW = 1MHz, Sweep: Auto.
3. Average measurements: RBW = 1MHz, VBW = 10 Hz, Sweep: Auto.
4. “ * ”, means this data is the worst emission level.
5. Measurement Level = Reading Level + Correct Factor.
6. The average measurement was not performed when the peak measured data under the limit of average detection. If the readings given are average, peak measurement should also be supplied.

Site : CB4-H	Time : 2017/09/24
Limit : FCC_SpartC_15.209_03M_AV	Margin : 6
Probe : CB4-H_FCC_A115_EFS_1-18GHz_1116 - VERTICAL	Power : DC 12V
EUT : Multimedia System	Note : 3DH5_2480MHz

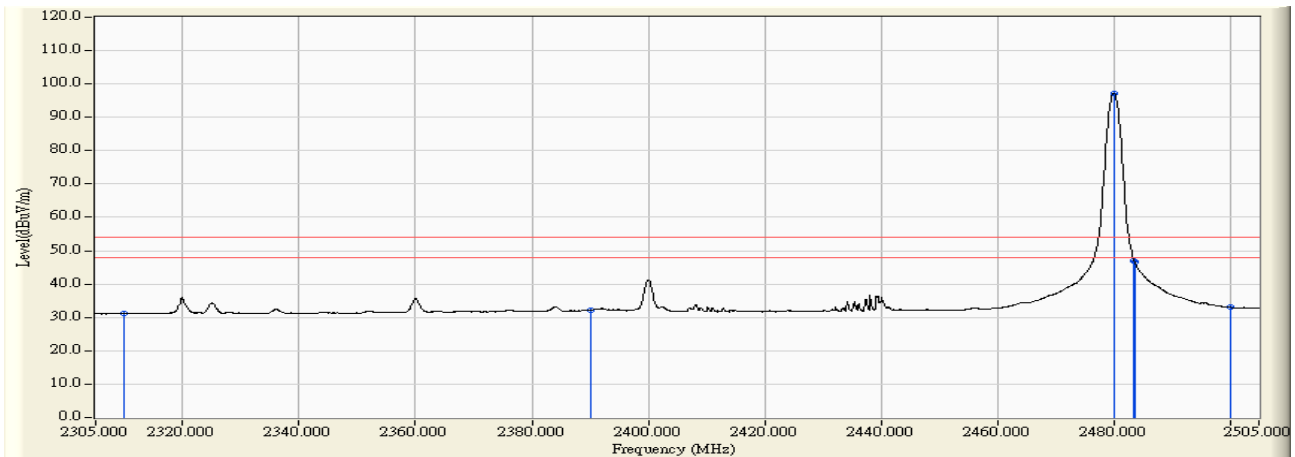

	Frequency (MHz)	Correct Factor (dB)	Reading Level (dBuV)	Measure Level (dBuV/m)	Margin (dB)	Limit (dBuV/m)	Detector Type
1	2310.000	13.428	17.674	31.102	-22.898	54.000	AVERAGE
2	2390.000	13.977	18.287	32.264	-21.736	54.000	AVERAGE
3	* 2480.000	14.595	82.645	97.240	43.240	54.000	AVERAGE
4	2483.500	14.619	32.243	46.862	-7.138	54.000	AVERAGE
5	2483.600	14.619	31.995	46.615	-7.385	54.000	AVERAGE
6	2500.000	14.728	18.265	32.993	-21.007	54.000	AVERAGE

Note:

1. All readings above 1GHz are performed with peak and/or average measurements as necessary.
2. Peak measurements: RBW = 1MHz, VBW = 1MHz, Sweep: Auto.
3. Average measurements: RBW = 1MHz, VBW = 10 Hz, Sweep: Auto.
4. “ * ”, means this data is the worst emission level.
5. Measurement Level = Reading Level + Correct Factor.
6. The average measurement was not performed when the peak measured data under the limit of average detection. If the readings given are average, peak measurement should also be supplied.

7. Number of hopping frequency

7.1. Test Equipment

The following test equipment is used during the test:

Number of hopping frequency / SR10-H

Instrument	Manufacturer	Model No.	Serial No	Next Cal. Date
Signal & Spectrum Analyzer	R&S	FSV40	101049	2017/01/23
EXA Signal Analyzer	Keysight	N9010A	MY51440132	2017/03/13
Spectrum Analyzer	Agilent	N9010A	US47140172	2017/07/26

Note: All equipment that need to calibrate are with calibration period of 1 year.

7.2. Test Setup

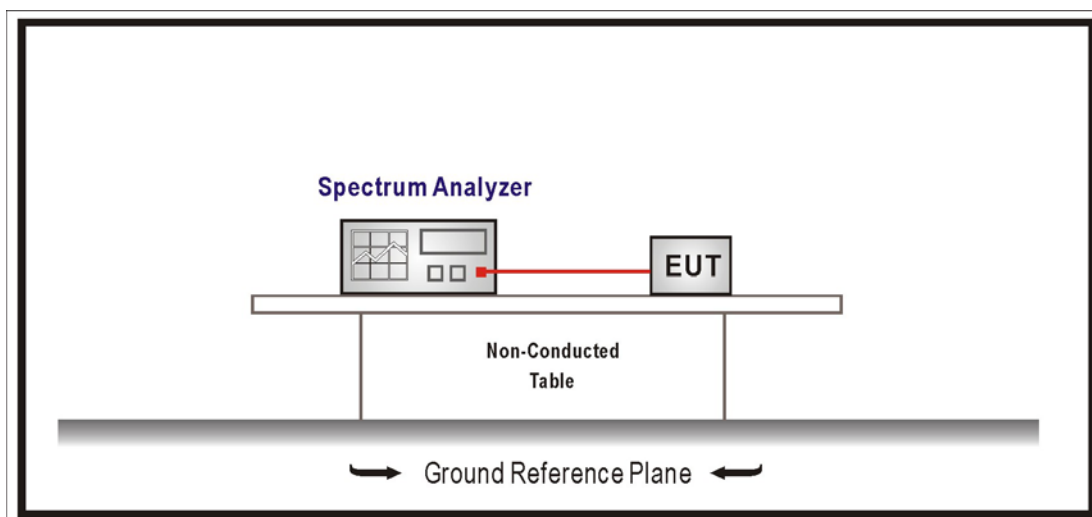

7.3. Limits

For frequency hopping systems operating in the 902-928 MHz band: if the 20 dB bandwidth of the hopping channel is less than 250 kHz, the system shall use at least 50 hopping frequencies and the average time of occupancy on any frequency shall not be greater than 0.4 seconds within a 20 second period; if the 20 dB bandwidth of the hopping channel is 250 kHz or greater, the system shall use at least 25 hopping frequencies and the average time of occupancy on any frequency shall not be greater than 0.4 seconds within a 10 second period. The maximum allowed 20 dB bandwidth of the hopping channel is 500 kHz.

For frequency hopping systems operating in the 2400-2483.5 MHz bands, which use fewer than 75 hopping frequencies, may employ intelligent hopping techniques to avoid interference to other transmissions. Frequency hopping systems may avoid or suppress transmissions on a particular hopping frequency provided that a minimum of 15 non-overlapping channels are used.

For frequency hopping systems operating in the 5725-5850 MHz band shall use at least 75 hopping frequencies.

7.4. Test Procedures

The EUT was setup according to ANSI C63.10:2013 and tested according to FHSS test procedure of FCC Public Notice DA 00-705 for compliance to FCC 47CFR 15.247 requirements ,

Span = the frequency band of operation , $RBW \geq 1\%$ of the span , $VBW \geq RBW$,

Sweep = auto, Detector function = peak, Trace = max hold.

7.5. Test Specification

According to FCC Part 15 Subpart C Paragraph 15.247: 2015

7.6. Test Result

Product	Multimedia System		
Test Item	Number of hopping frequency		
Test Mode	Mode 1: Transmit		
Date of Test	2017/09/27	Test Site	SR10-H

Frequency Range (MHz)	Measure Level (Channels)	Limit (Channels)	Result
2402 - 2480	79	≥ 75	Pass

2401.5-2420.5MHz

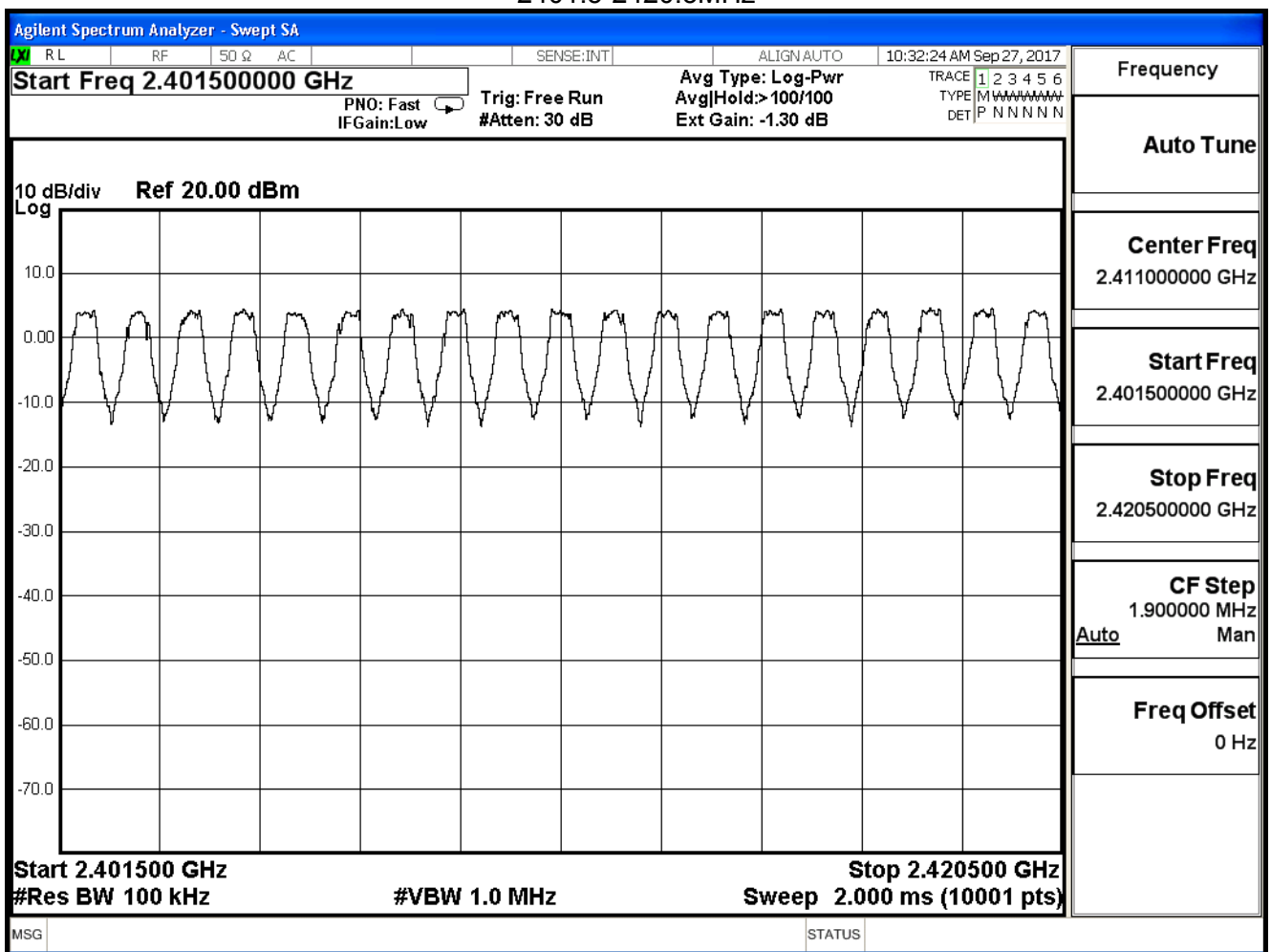

2420.5-2440.5MHz

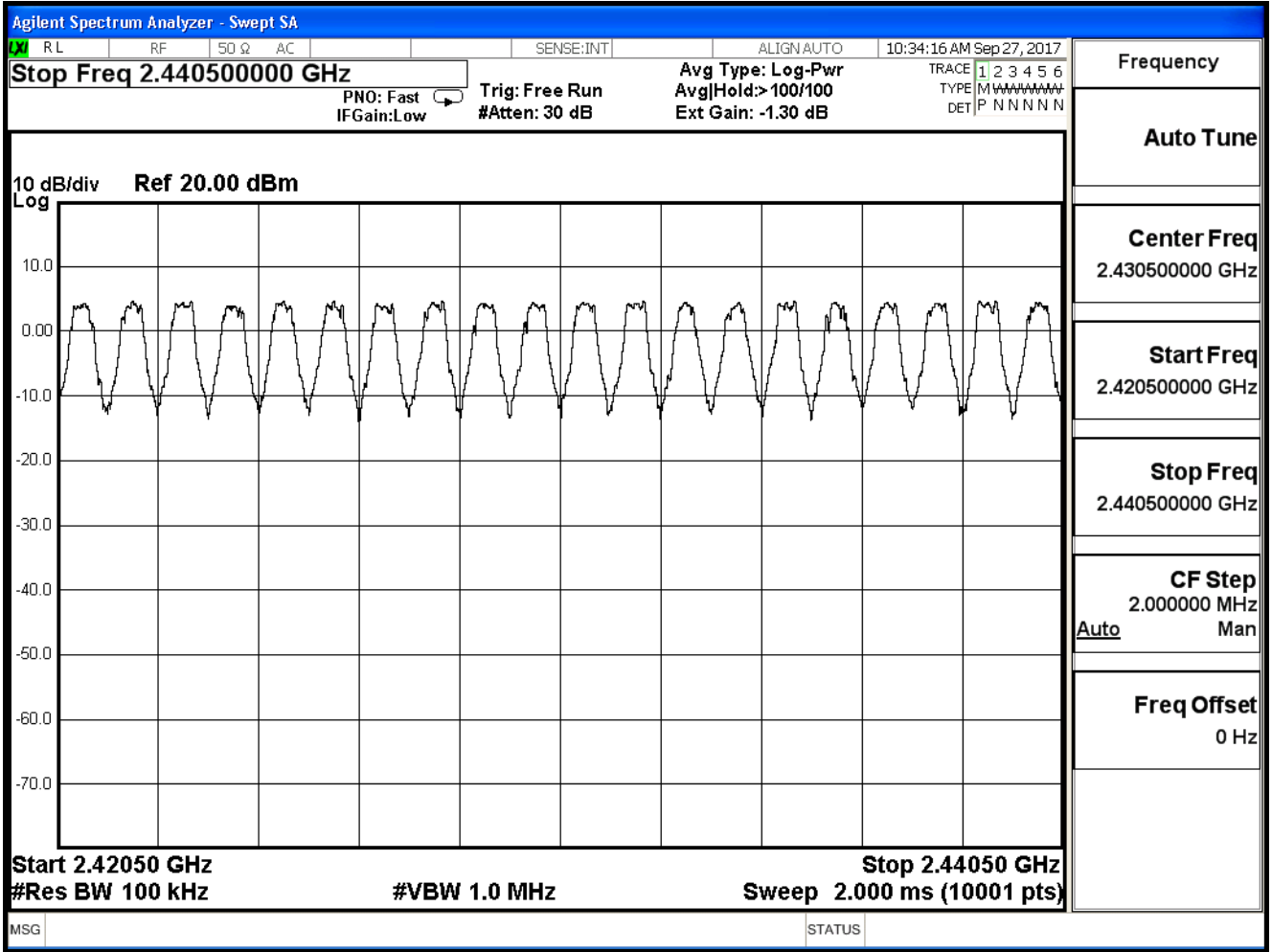

2440.5-2460.5MHz

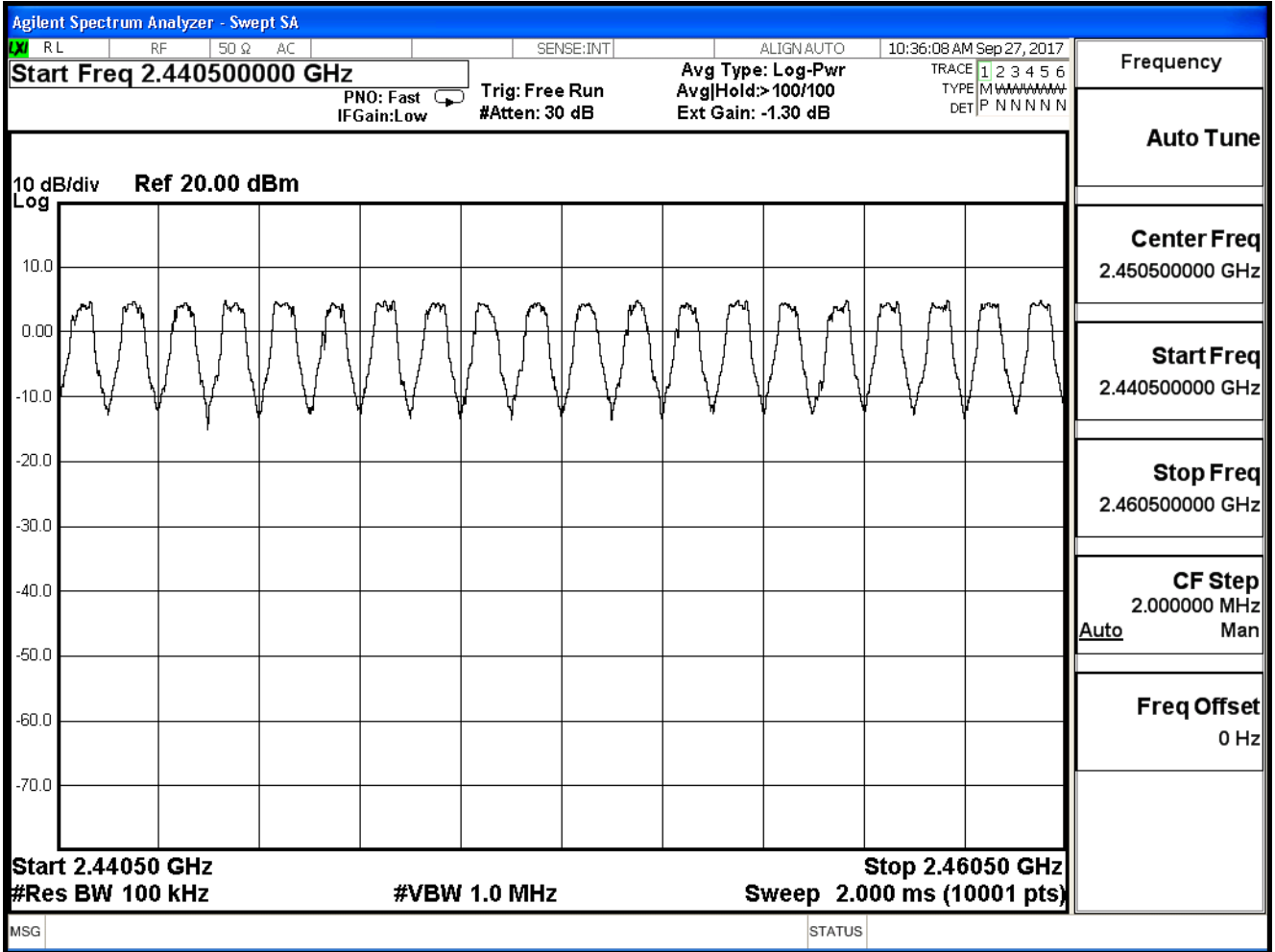

2460.5-2480.5MHz

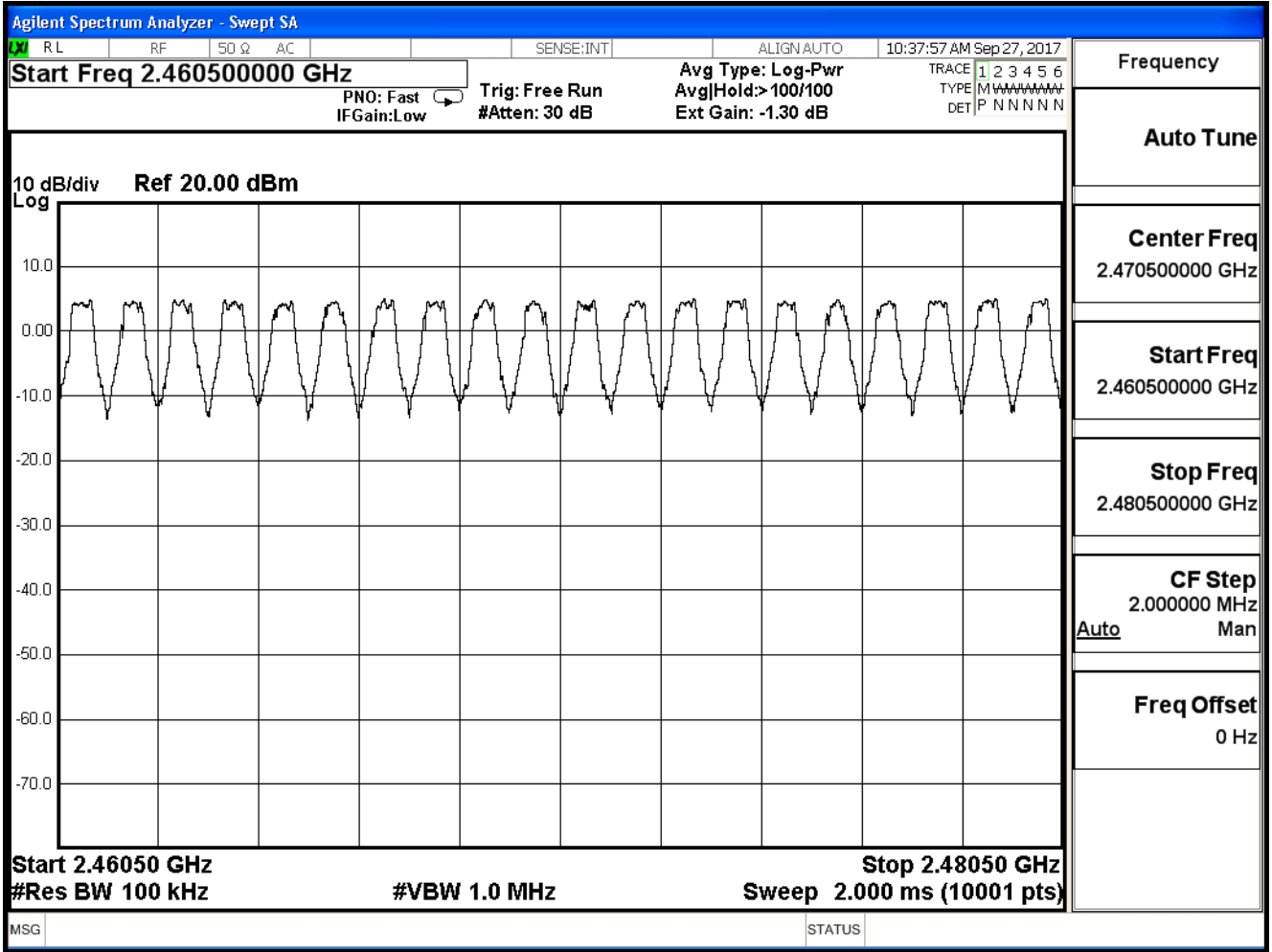

8. Carrier Frequency Separation

8.1. Test Equipment

The following test equipment is used during the test:

Carrier Frequency Separation / SR10-H

Instrument	Manufacturer	Model No.	Serial No	Next Cal. Date
Signal & Spectrum Analyzer	R&S	FSV40	101049	2017/01/23
EXA Signal Analyzer	Keysight	N9010A	MY51440132	2017/03/13
High Speed Peak Power Meter Dual Input	Anritsu	ML2496A	1602004	2017/01/20
Pulse Power Sensor	Anritsu	MA2411B	1531043	2017/01/20
Pulse Power Sensor	Anritsu	MA2411B	1531044	2017/01/20

Note: All equipment that need to calibrate are with calibration period of 1 year.

8.2. Test Setup

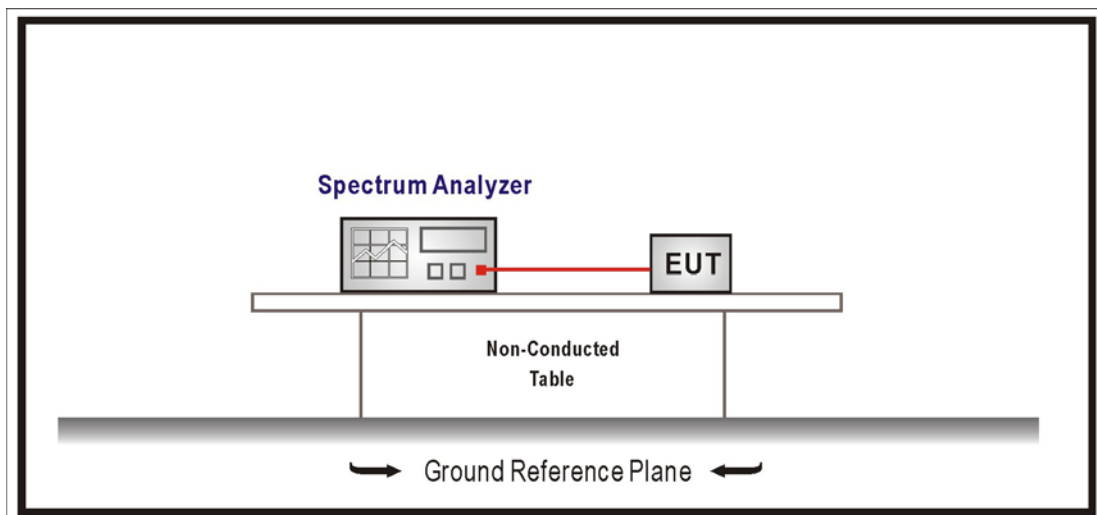

8.3. Limits

For frequency hopping systems shall have hopping channel carrier frequencies separated by a minimum of 25 kHz or two-thirds of the 20 dB bandwidth of the hopping channel, whichever is greater.

8.4. Test Procedures

The EUT was setup according to ANSI C63.10:2013 and tested according to FHSS test procedure of FCC Public Notice DA 00-705 for compliance to FCC 47CFR 15.247 requirements

Span = wide enough to capture the peaks of two adjacent channels

Resolution Bandwidth (RBW) \geq 1% of the span, VBW \geq RBW

Sweep = auto, Detector function = peak, Trace = max hold

8.5. Test Specification

According to FCC Part 15 Subpart C Paragraph 15.247: 2015

8.6. Test Result

Product	Multimedia System		
Test Item	Carrier Frequency Separation		
Test Mode	Mode 1: Transmit		
Date of Test	2017/09/27	Test Site	SR10-H

GFSK

Channel No.	Frequency (MHz)	Measure Level (MHz)	Limit (MHz)	Result
00	2402	1.004	0.626	Pass
39	2441	1.006	0.628	Pass
78	2480	1.014	0.628	Pass

Channel 00

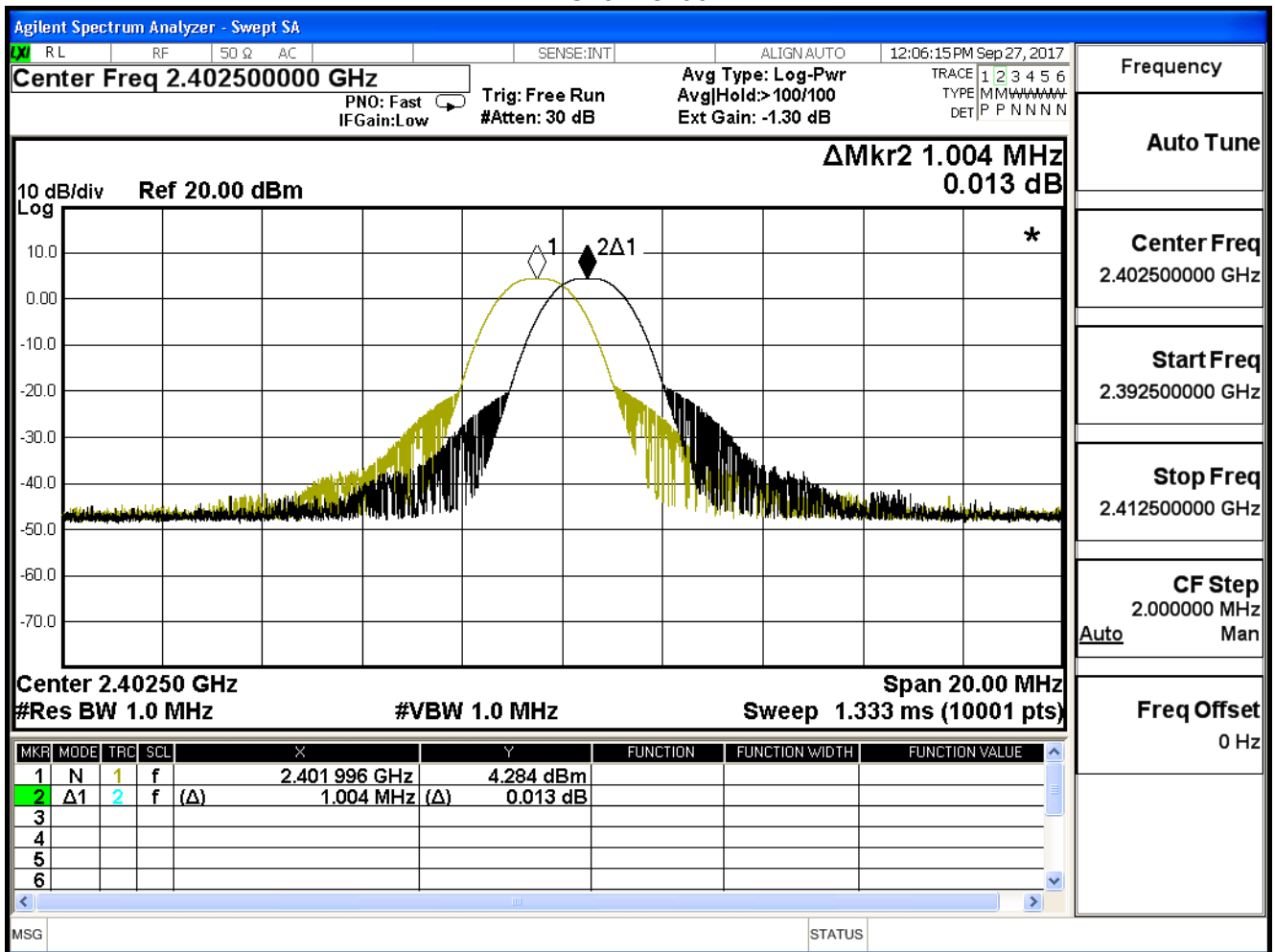

Channel 39

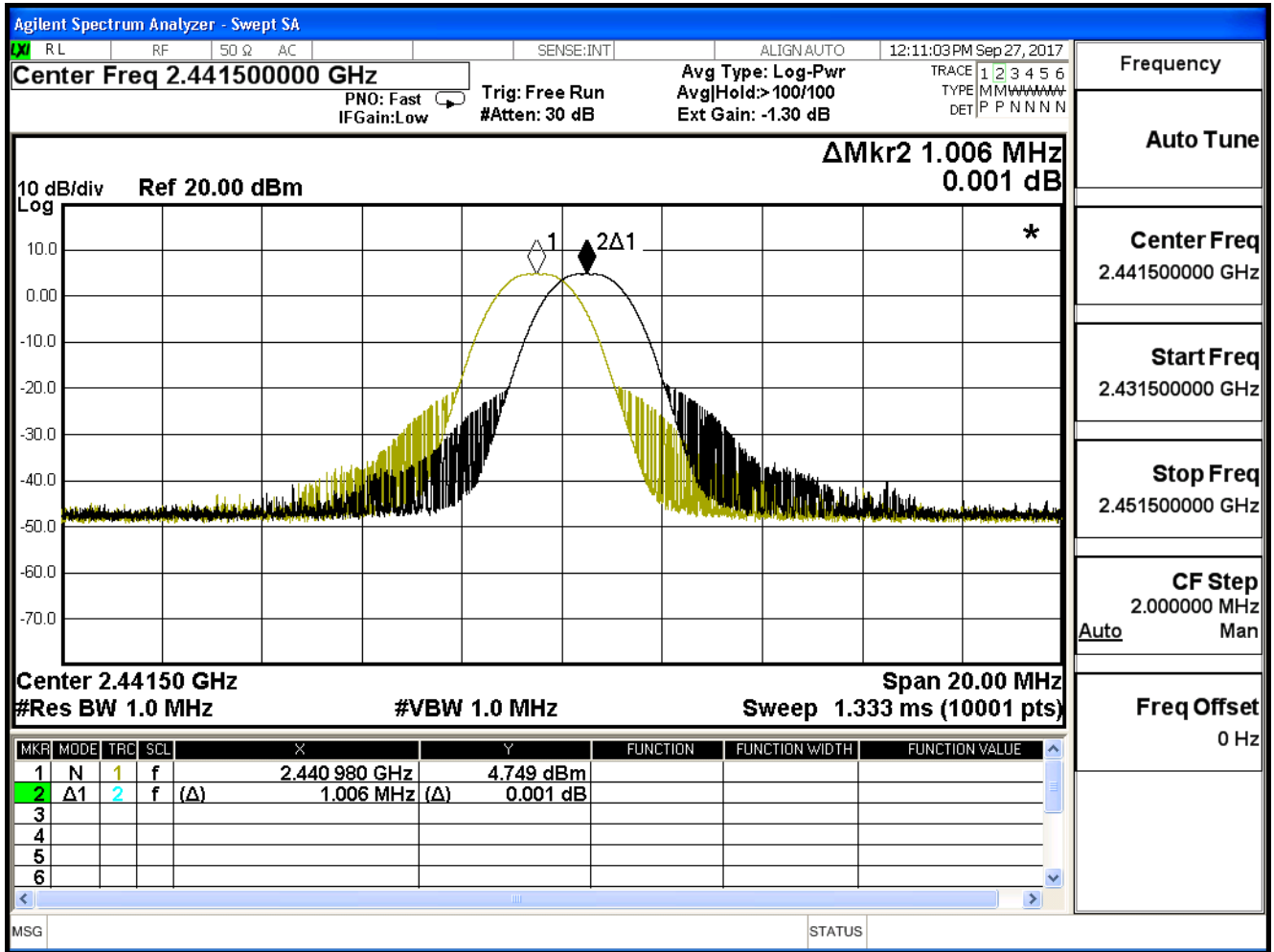

Channel 78

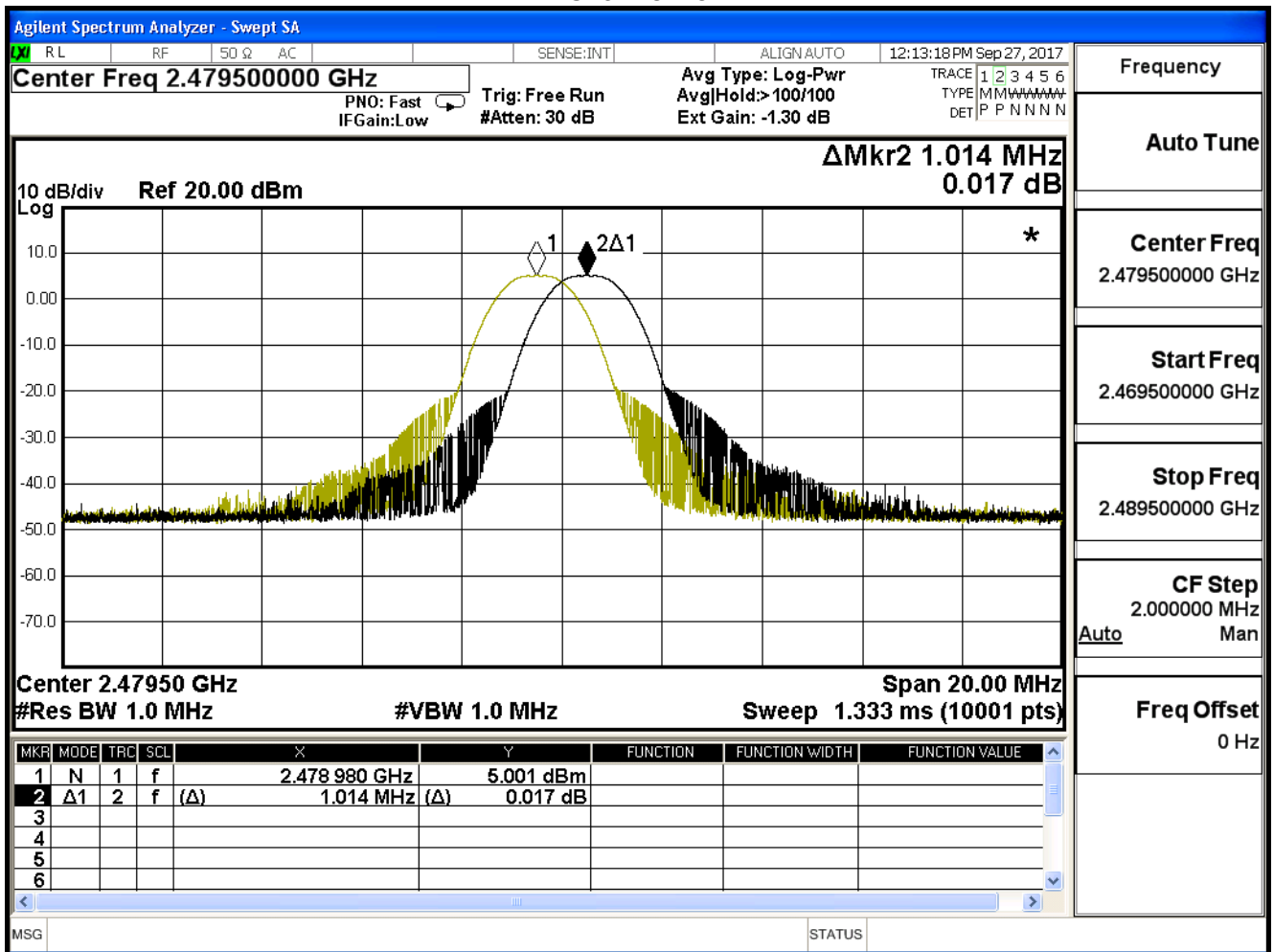

Product	Multimedia System		
Test Item	Carrier Frequency Separation		
Test Mode	Mode 1: Transmit		
Date of Test	2017/09/27	Test Site	SR10-H

$\pi/4$ -DQPSK

Channel No.	Frequency (MHz)	Measure Level (MHz)	Limit (MHz)	Result
00	2402	1.014	0.950	Pass
39	2441	0.982	0.949	Pass
78	2480	1.012	0.951	Pass

Channel 00

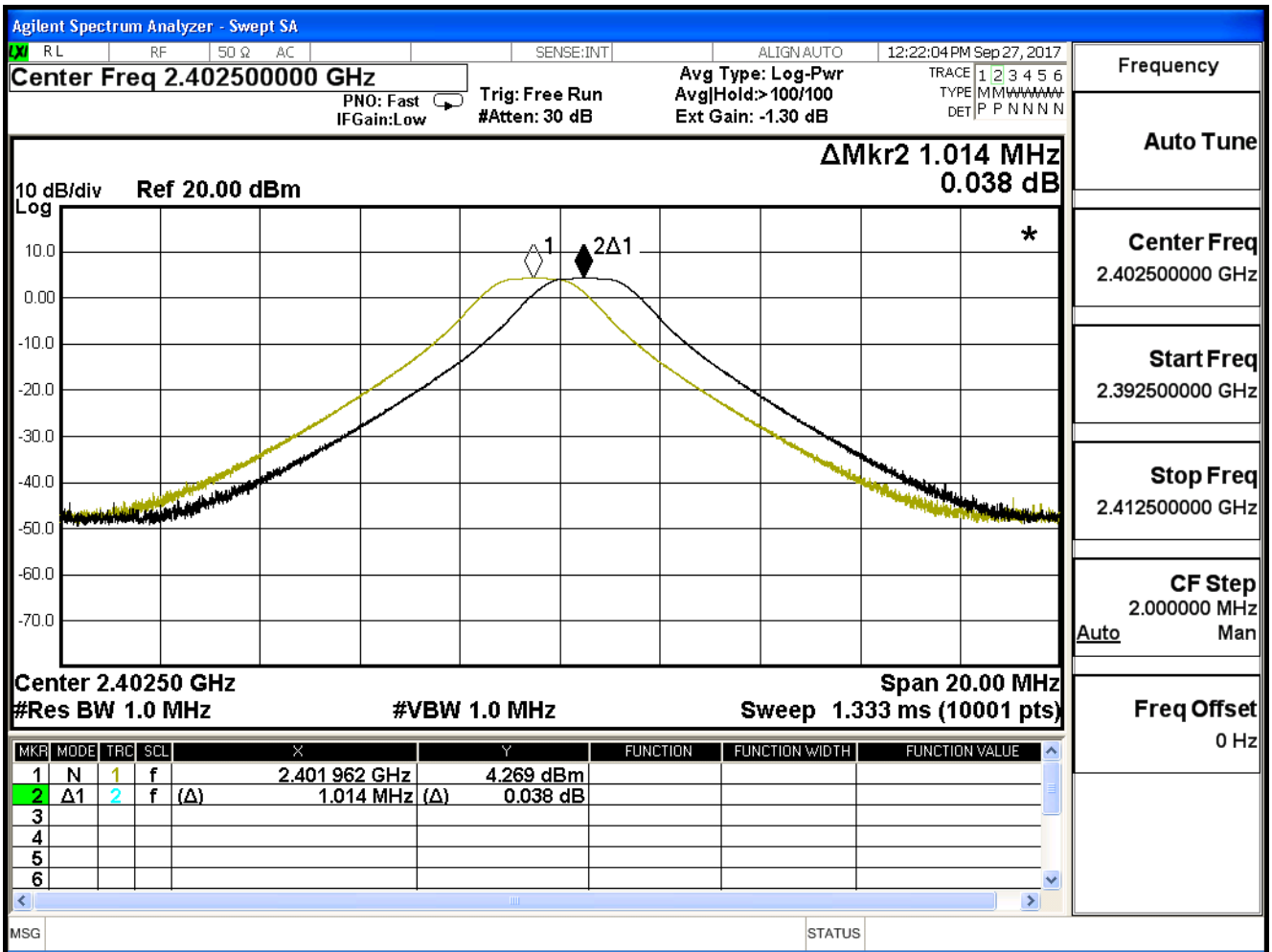

Channel 39

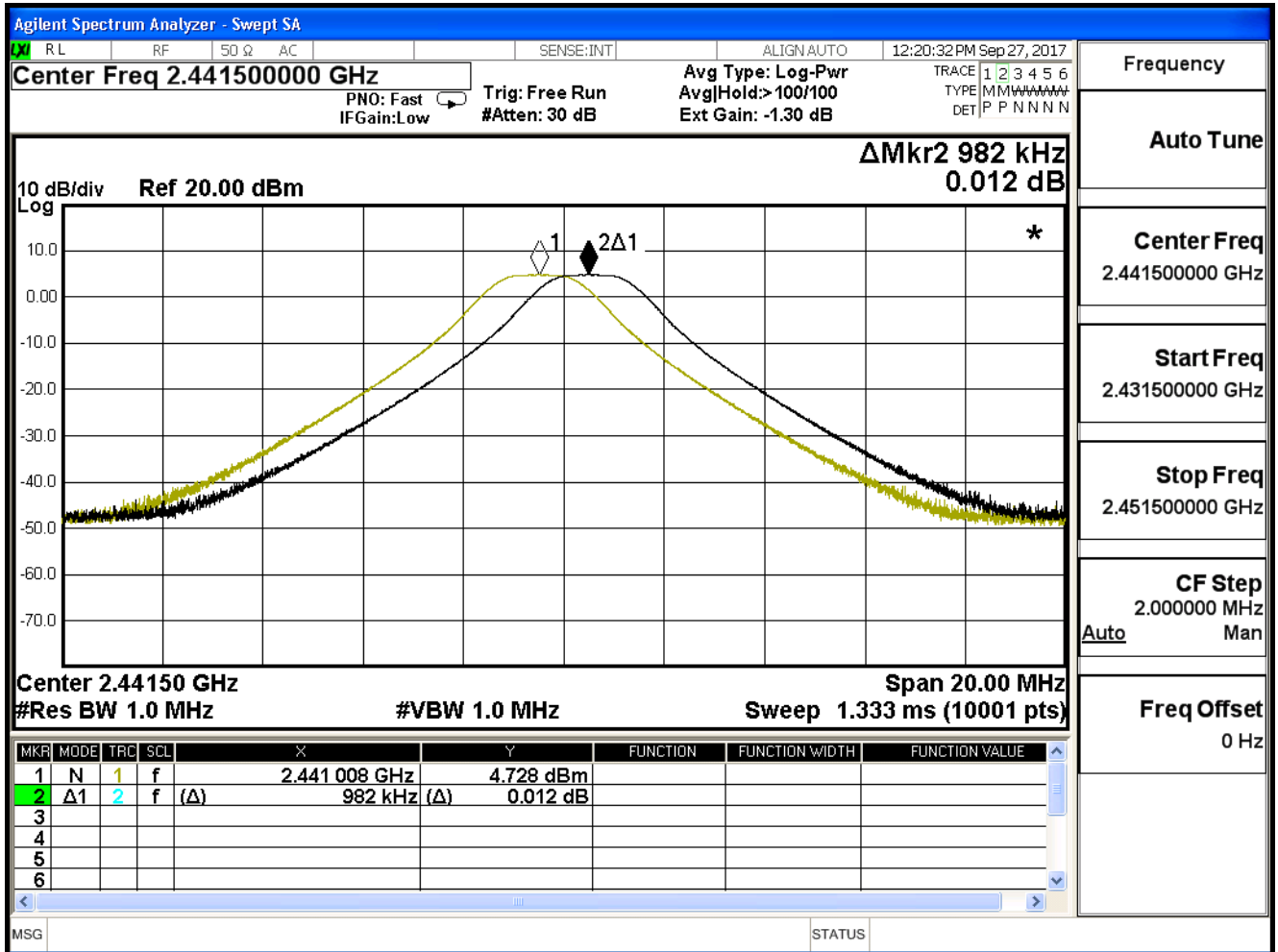

Channel 78

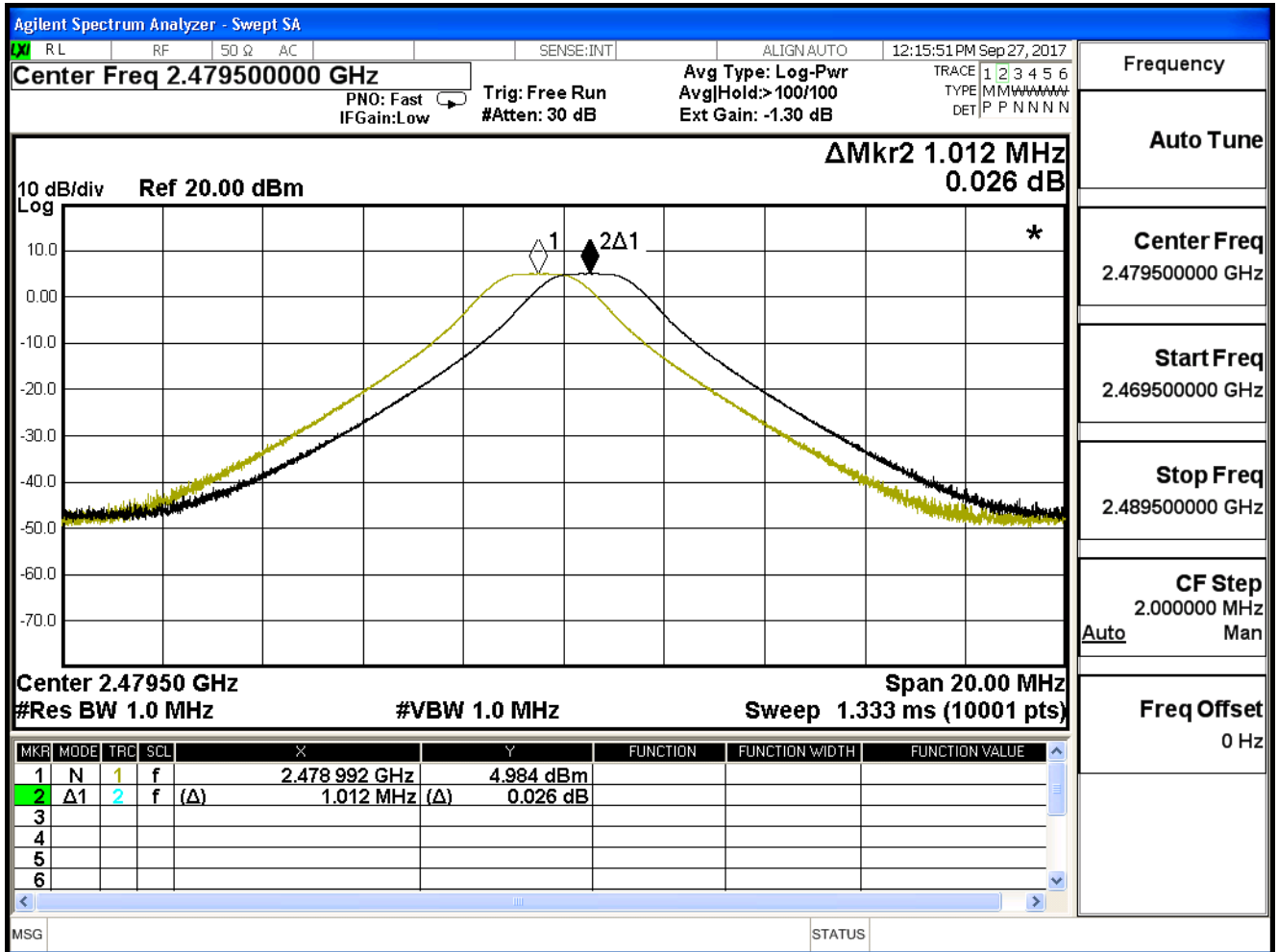

Product	Multimedia System		
Test Item	Carrier Frequency Separation		
Test Mode	Mode 1: Transmit		
Date of Test	2017/09/27	Test Site	SR10-H

8-DPSK

Channel No.	Frequency (MHz)	Measure Level (MHz)	Limit (MHz)	Result
00	2402	0.984	0.926	Pass
39	2441	0.990	0.930	Pass
78	2480	1.008	0.926	Pass

Channel 00

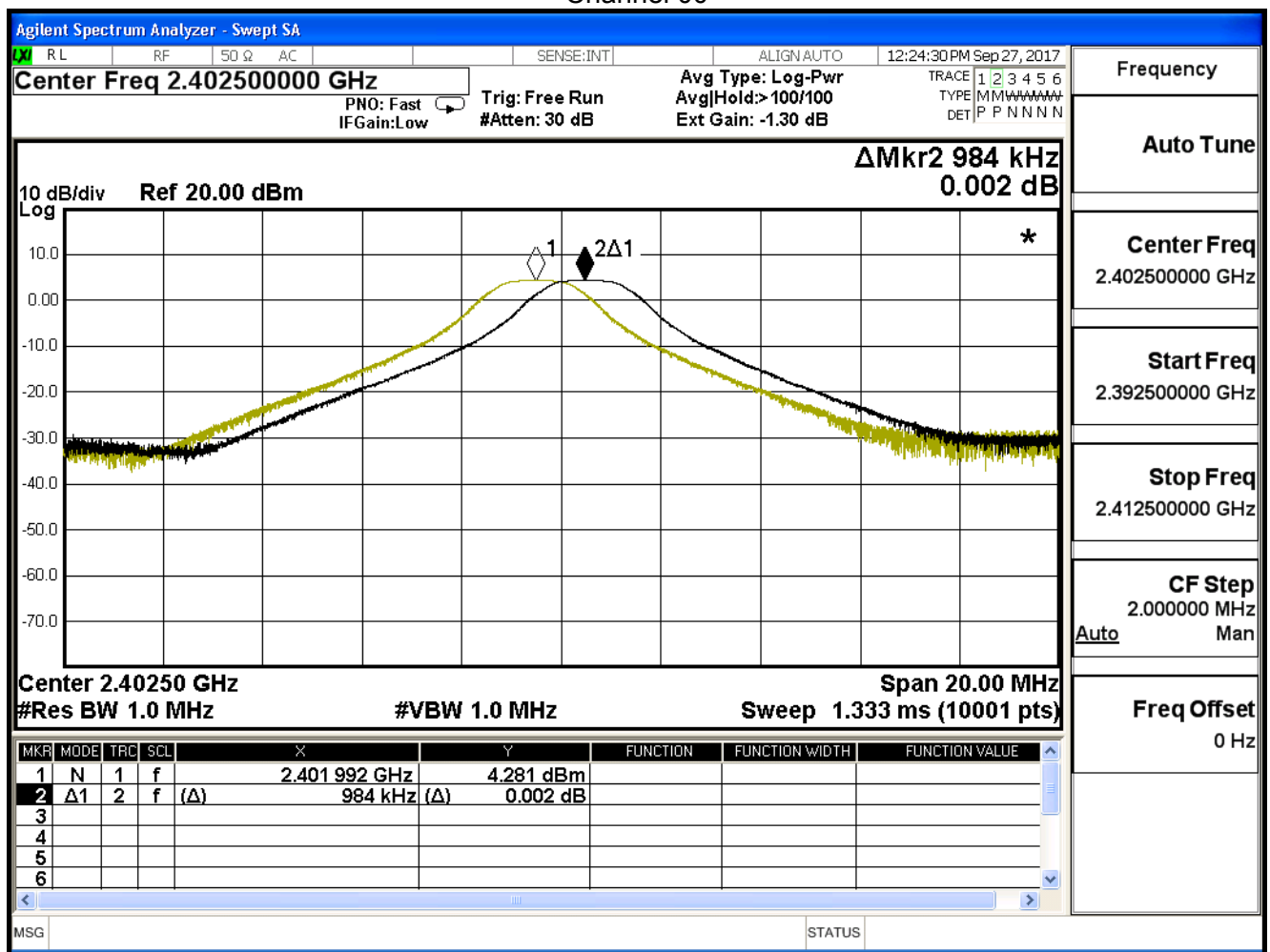

Channel 39

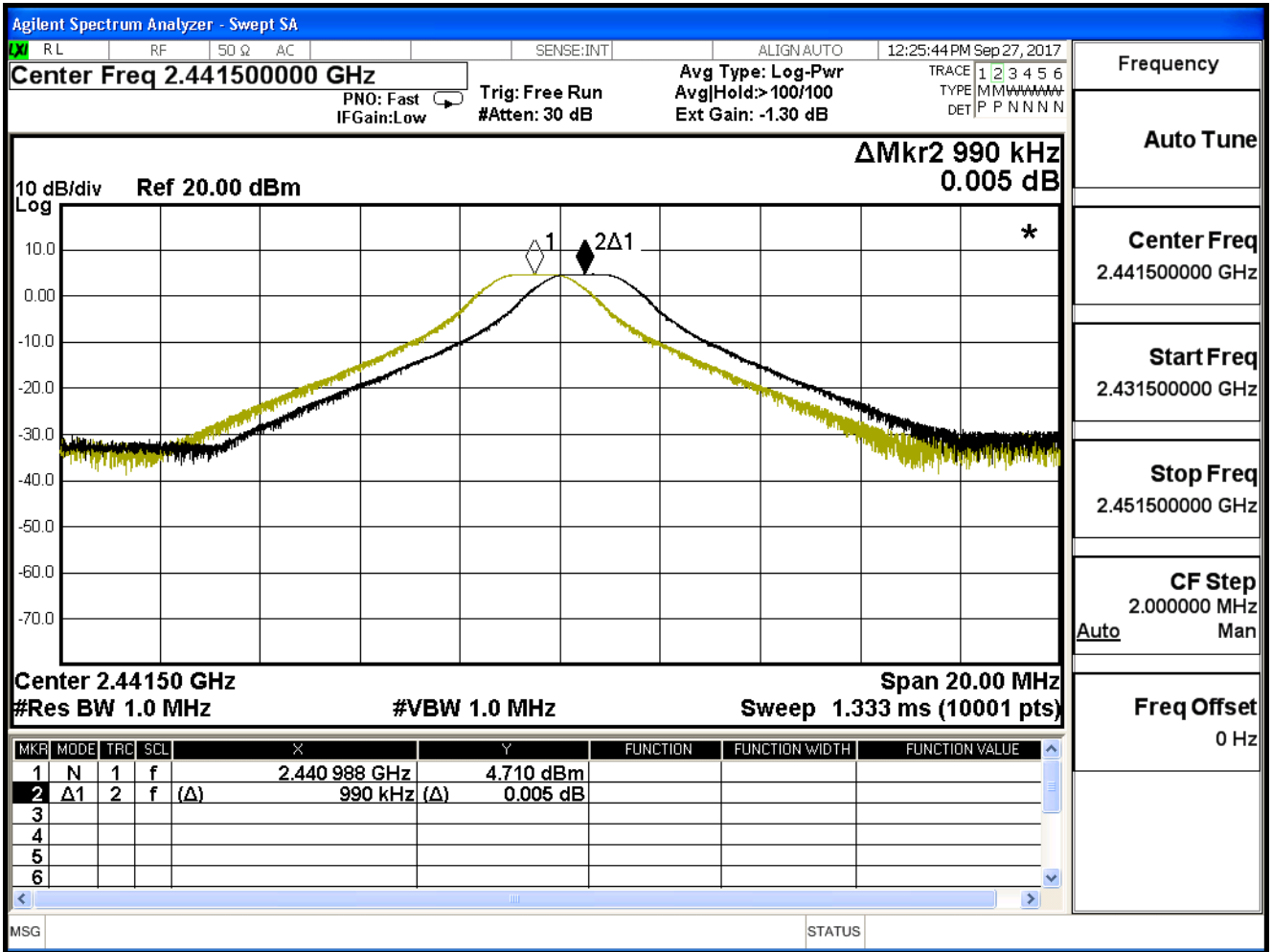

Channel 78

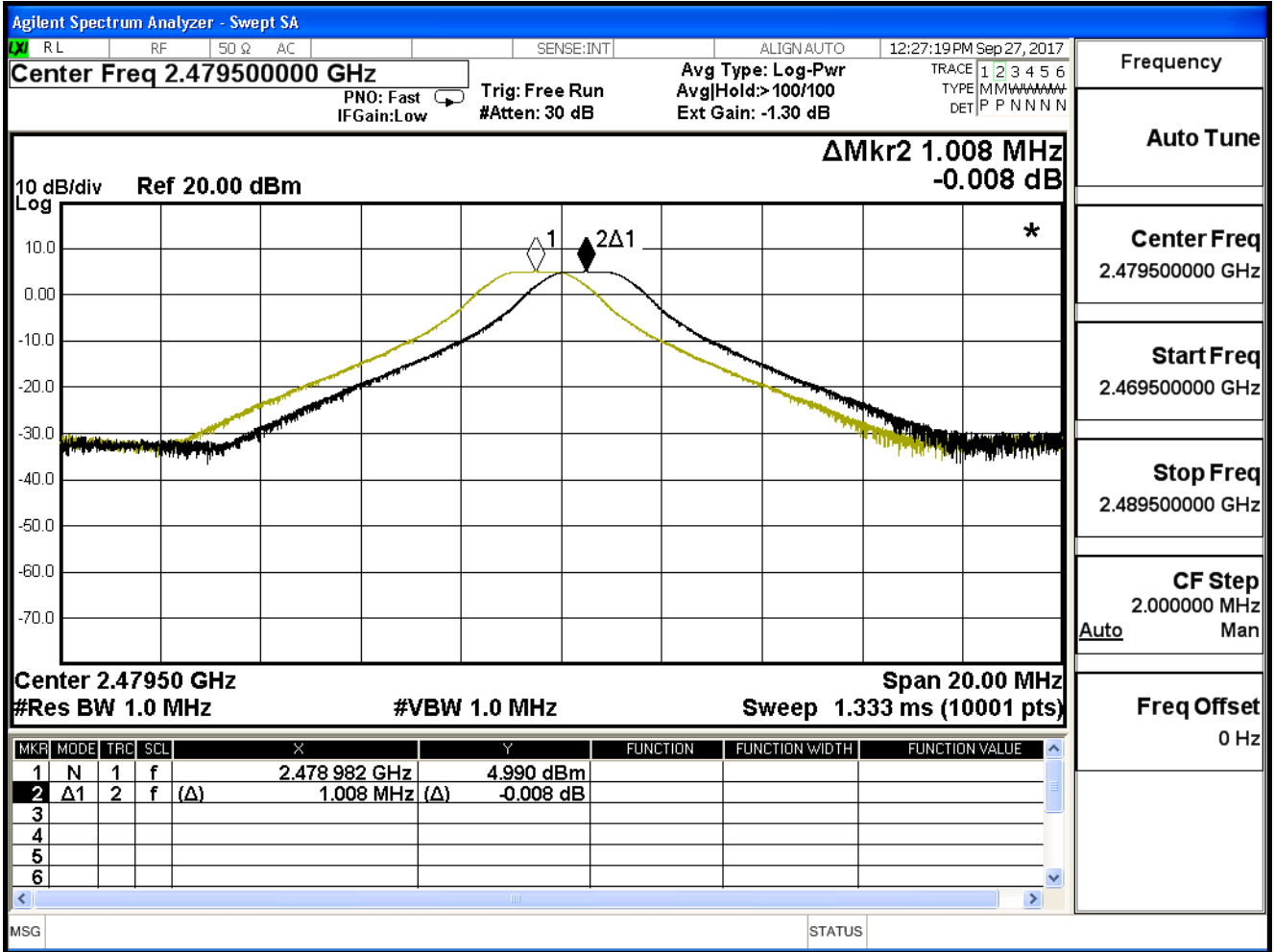

9. Occupied Bandwidth

9.1. Test Equipment

The following test equipment is used during the test:

Occupied Bandwidth / SR10-H

Instrument	Manufacturer	Model No.	Serial No	Next Cal. Date
Signal & Spectrum Analyzer	R&S	FSV40	101049	2017/01/23
EXA Signal Analyzer	Keysight	N9010A	MY51440132	2017/03/13
Spectrum Analyzer	Agilent	N9010A	US47140172	2017/07/26

Note: All equipment that need to calibrate are with calibration period of 1 year.

9.2. Test Setup

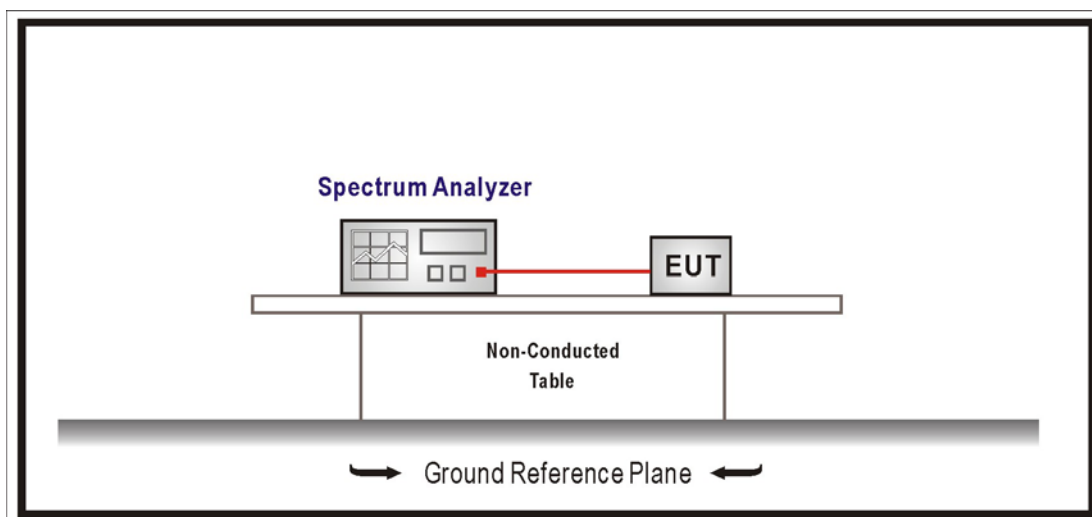

9.3. Limits

N/A

9.4. Test Procedures

The EUT was setup according to ANSI C63.10:2013 and tested according to FHSS test procedure of FCC Public Notice DA 00-705 for compliance to FCC 47CFR 15.247 requirements

Use the following spectrum analyzer settings:

Span = approximately 2 to 3 times the 20 dB bandwidth, centered on a hopping channel

RBW \geq 1% of the 20 dB bandwidth, VBW \geq RBW , Sweep = auto, Detector function = peak,

Trace = max hold , The EUT should be transmitting at its maximum data rate.

9.5. Test Specification

According to FCC Part 15 Subpart C Paragraph 15.247: 2015

9.6. Test Result

Product	Multimedia System		
Test Item	Occupied Bandwidth		
Test Mode	Mode 1: Transmit		
Date of Test	2017/09/27	Test Site	SR10-H

GFSK

Channel No.	Frequency (MHz)	Measure Level (MHz)	Limit (MHz)	Result
00	2402	0.940	--	Pass
39	2441	0.943	--	Pass
78	2480	0.942	--	Pass

Channel 00

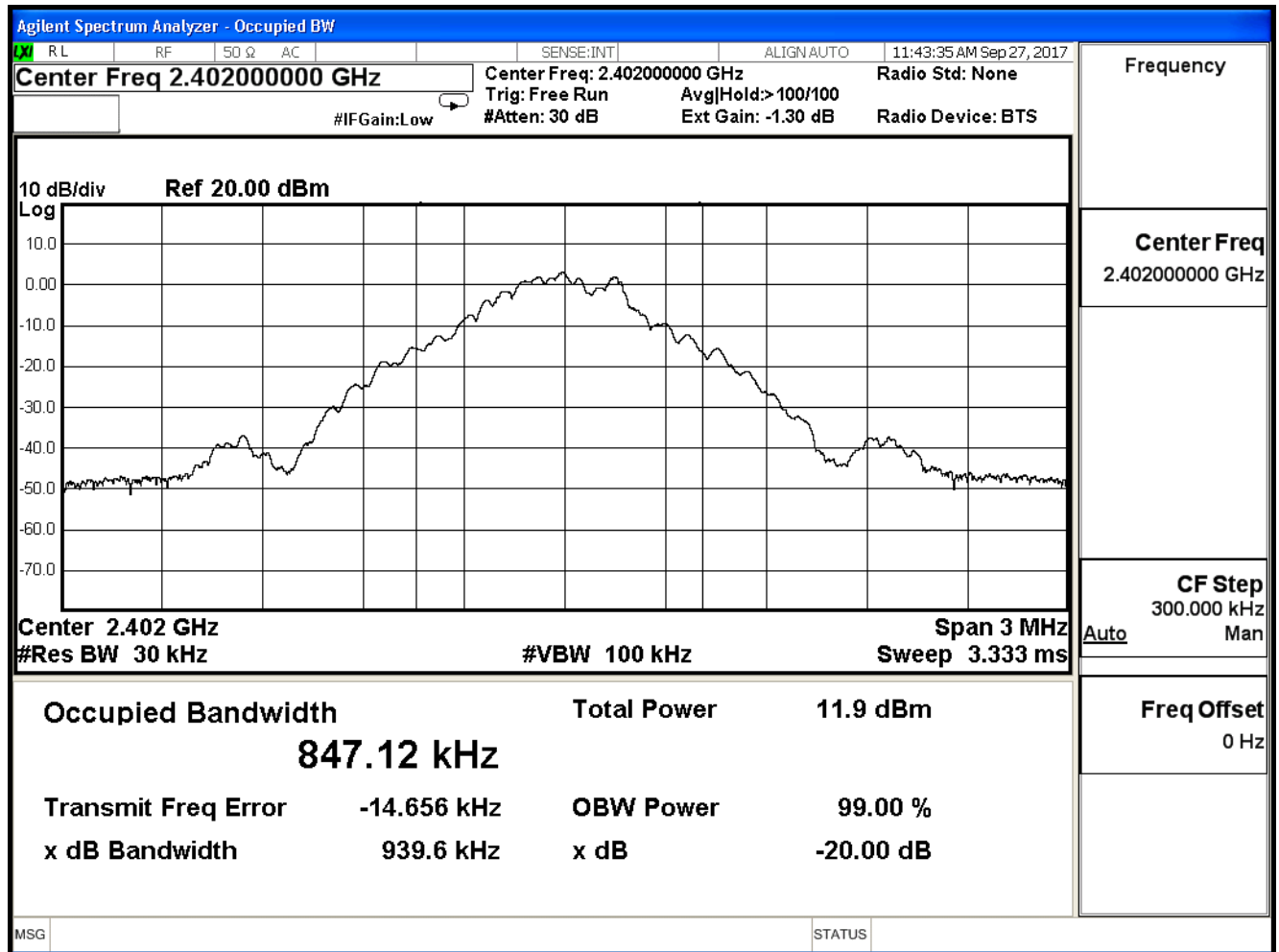

Channel 39

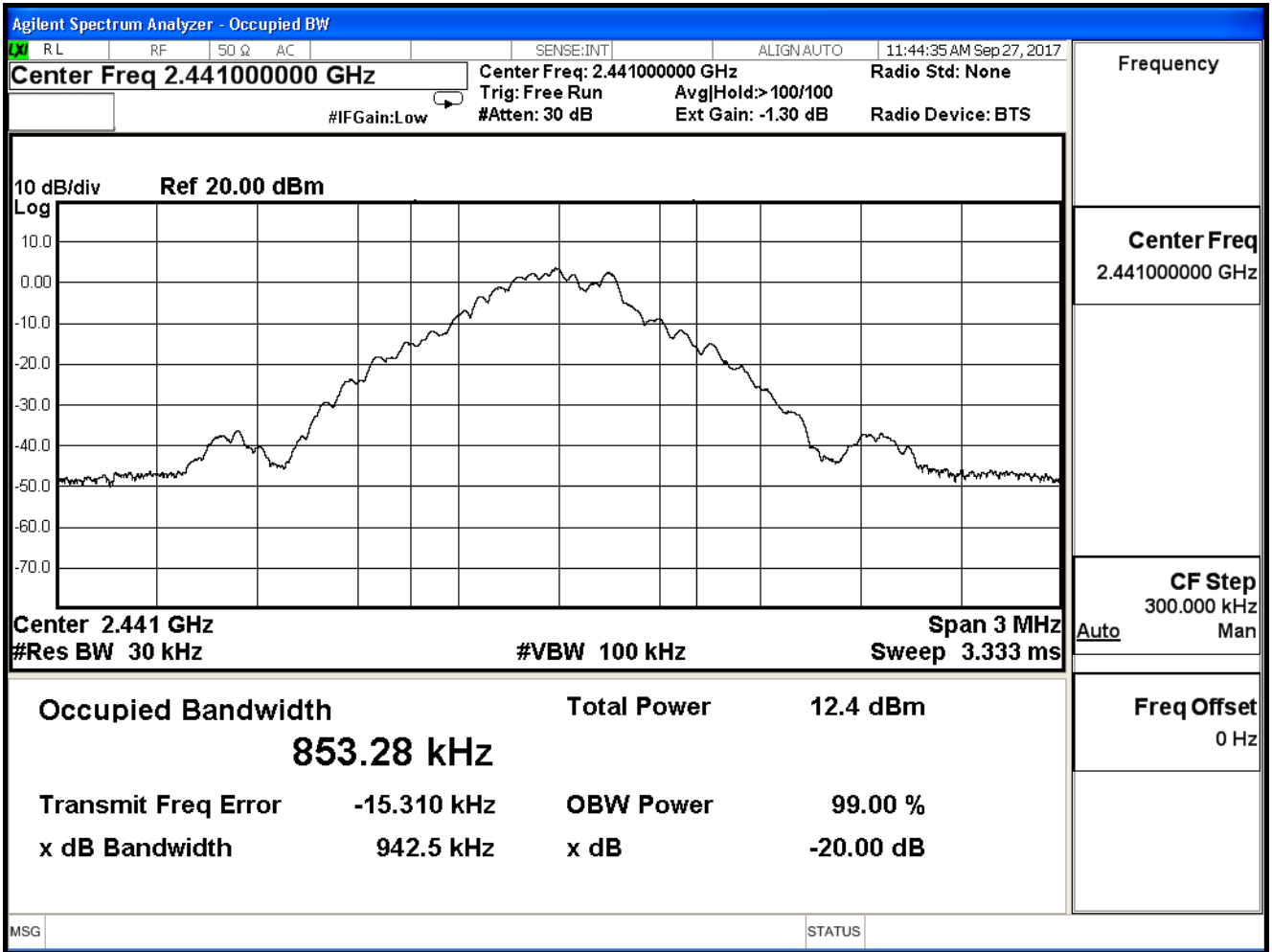

Channel 78

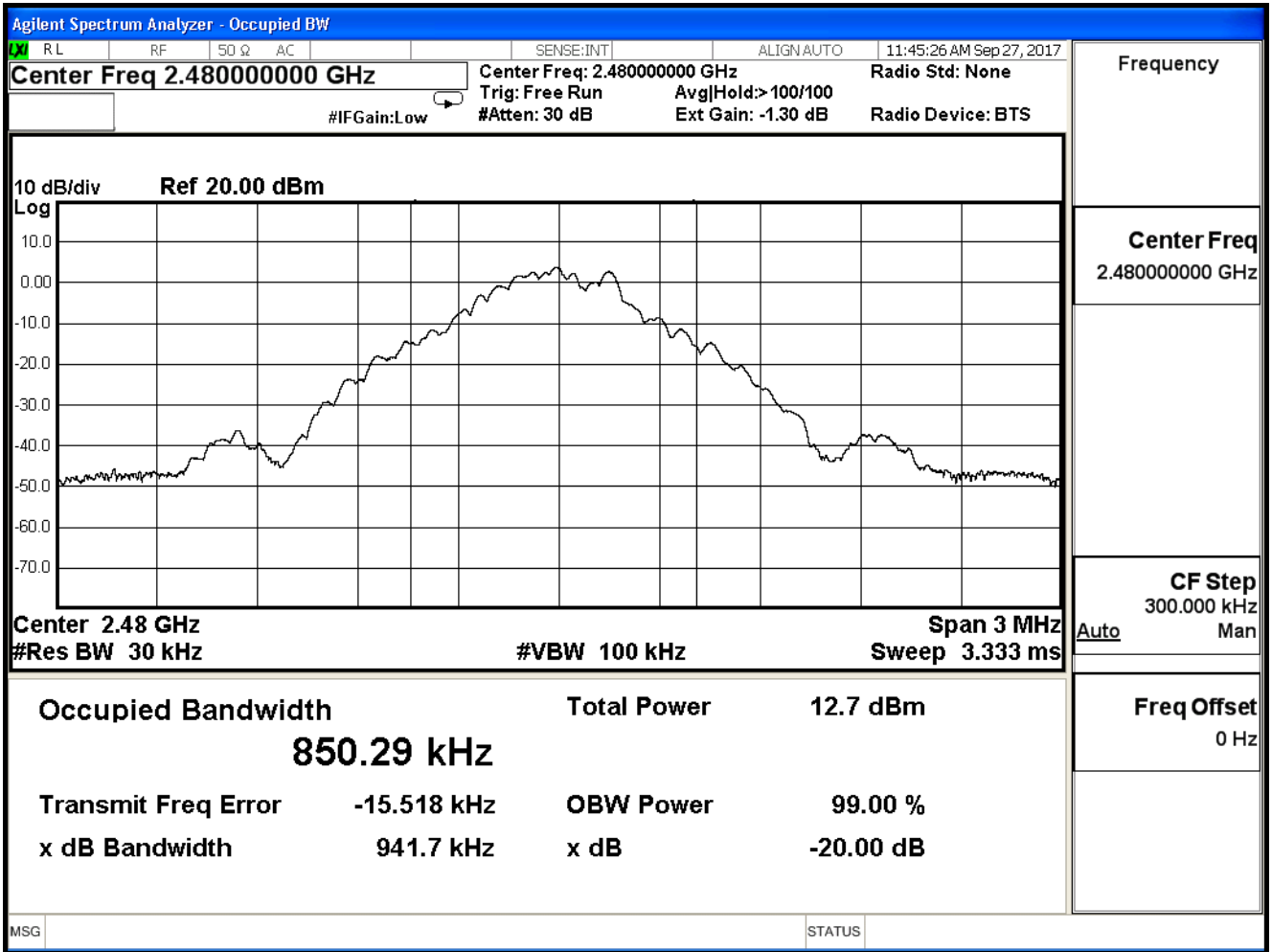

Product	Multimedia System		
Test Item	Occupied Bandwidth		
Test Mode	Mode 1: Transmit		
Date of Test	2017/09/27	Test Site	SR10-H

$\pi/4$ -DQPSK

Channel No.	Frequency (MHz)	Measure Level (MHz)	Limit (MHz)	Result
00	2402	1.425	--	Pass
39	2441	1.424	--	Pass
78	2480	1.426	--	Pass

Channel 00

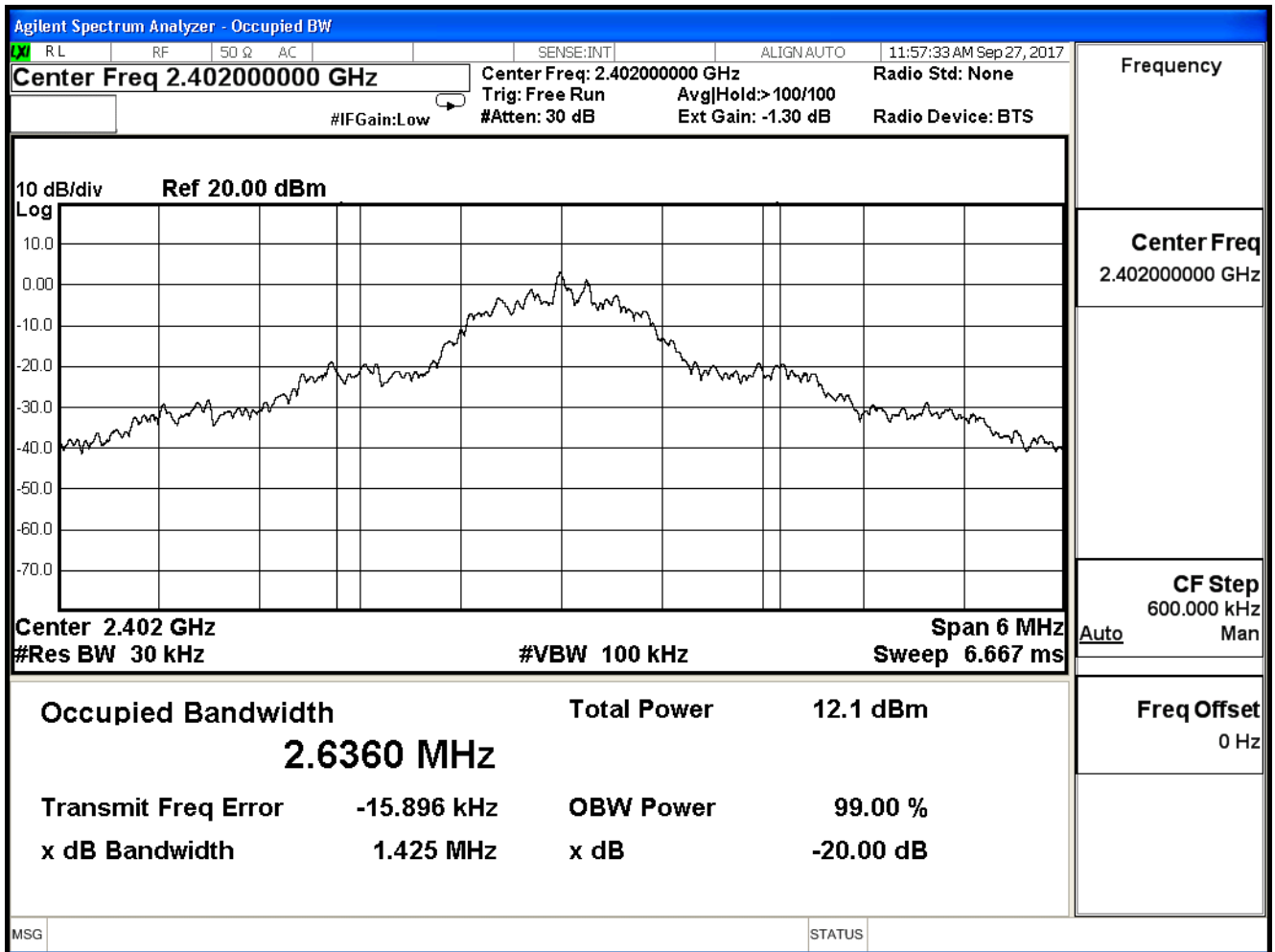

Channel 39

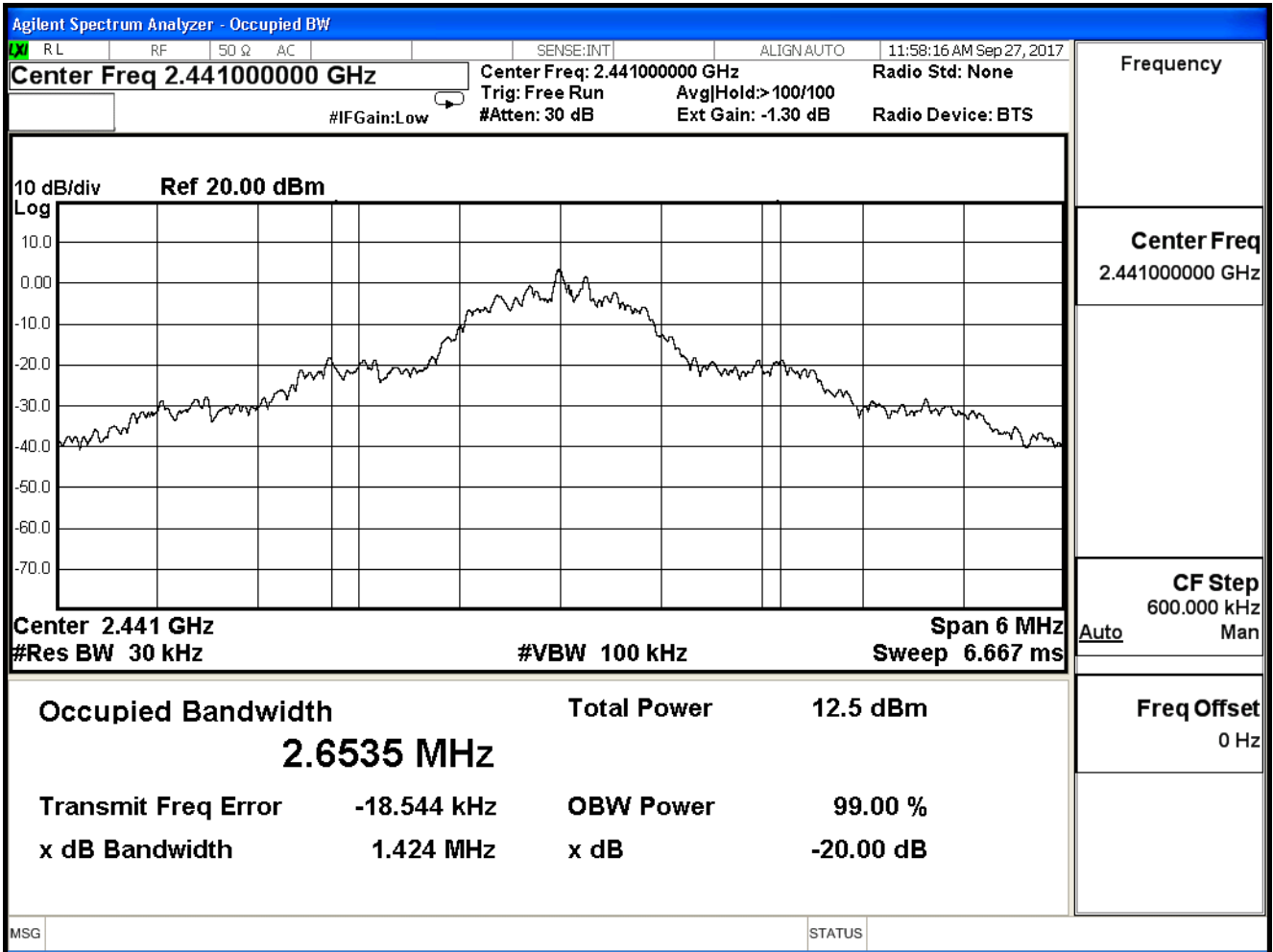

Channel 78

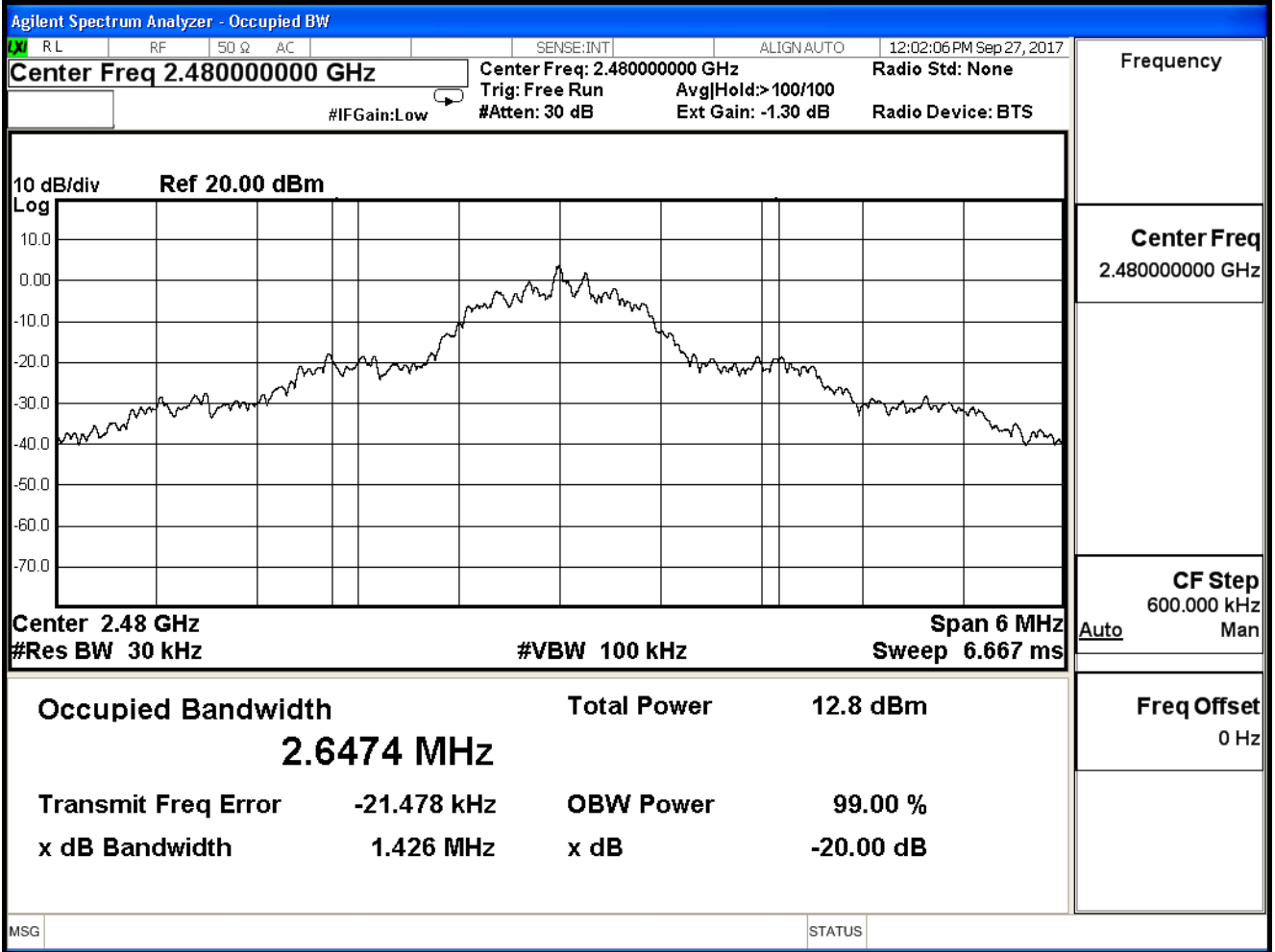

Product	Multimedia System		
Test Item	Occupied Bandwidth		
Test Mode	Mode 1: Transmit		
Date of Test	2017/09/27	Test Site	SR10-H

8-DPSK

Channel No.	Frequency (MHz)	Measure Level (MHz)	Limit (MHz)	Result
00	2402	1.389	--	Pass
39	2441	1.395	--	Pass
78	2480	1.389	--	Pass

Channel 00

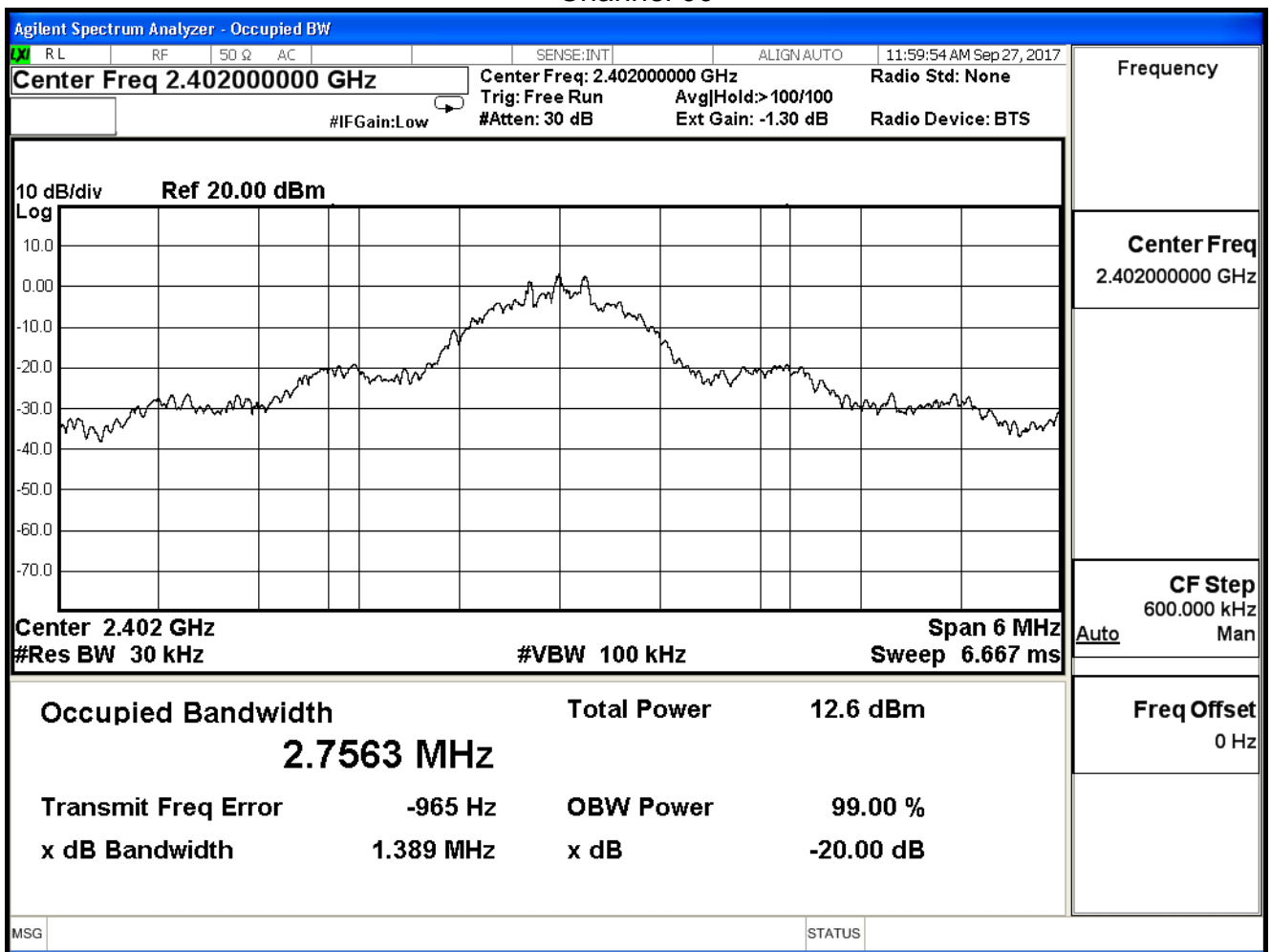

Channel 39

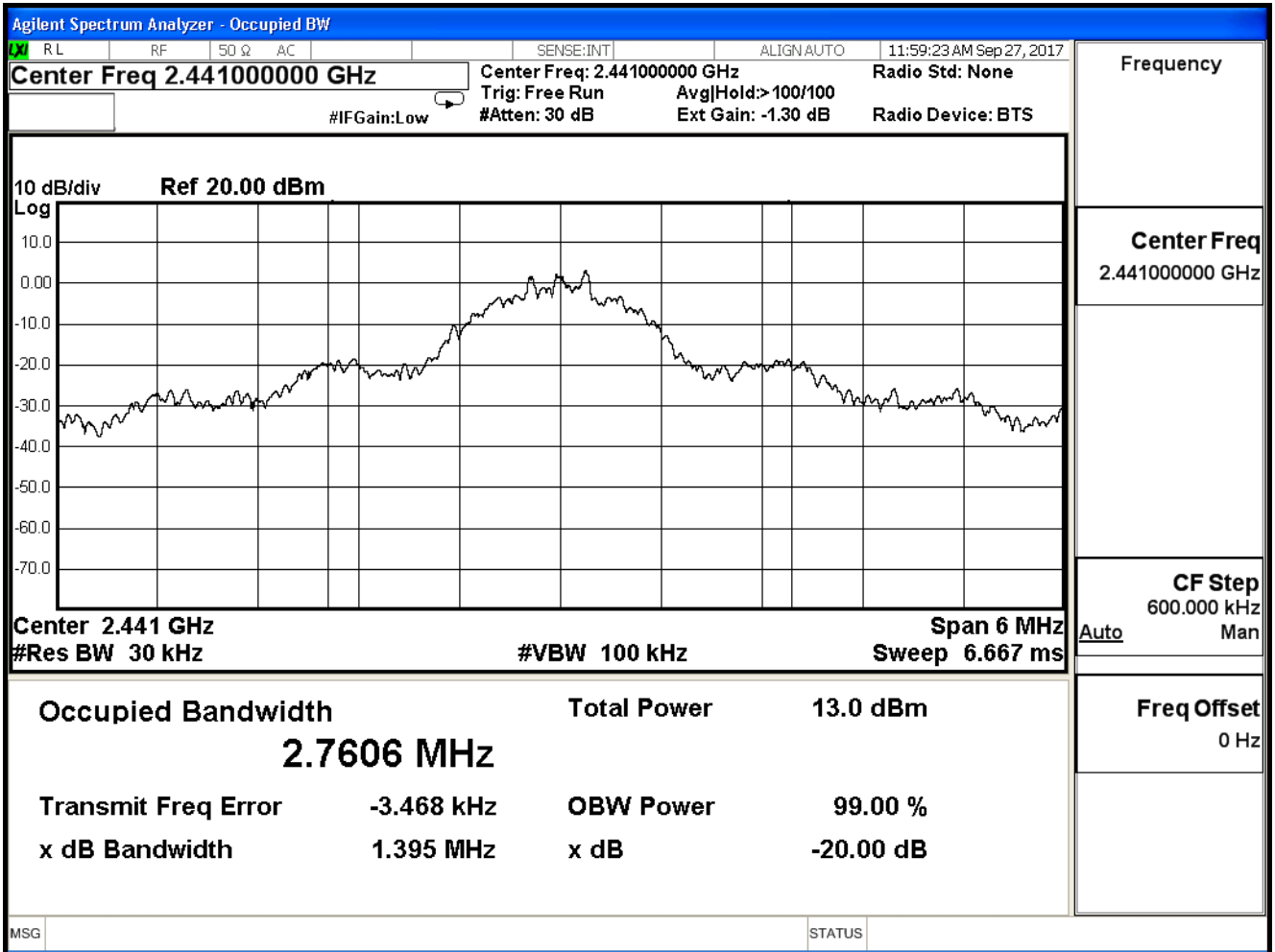

Channel 78

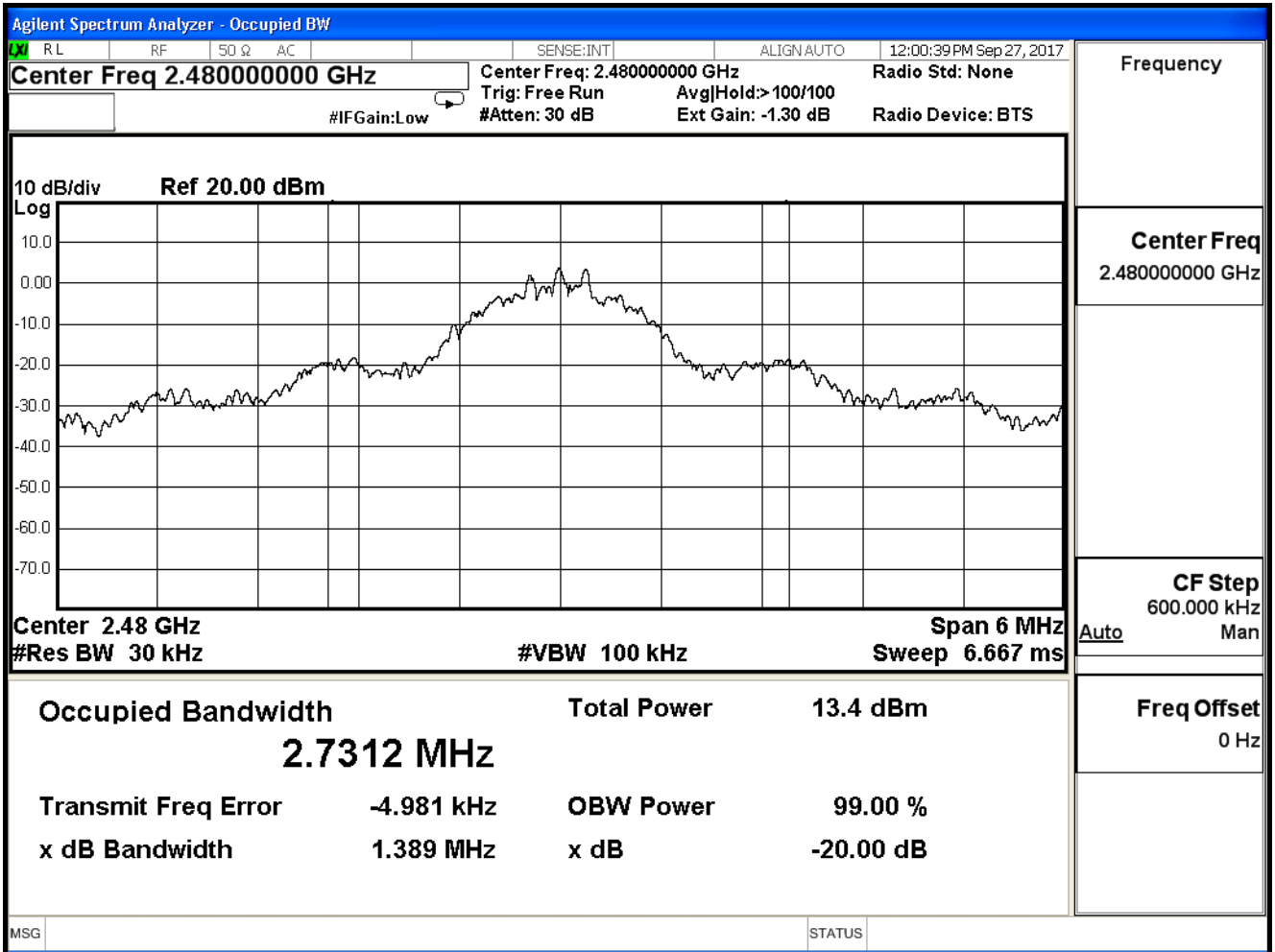

10. Dwell Time

10.1. Test Equipment

The following test equipment is used during the test:

Dwell Time / SR10-H

Instrument	Manufacturer	Model No.	Serial No	Next Cal. Date
Signal & Spectrum Analyzer	R&S	FSV40	101049	2017/01/23
EXA Signal Analyzer	Keysight	N9010A	MY51440132	2017/03/13

Note: All equipment that need to calibrate are with calibration period of 1 year.

10.2. Test Setup

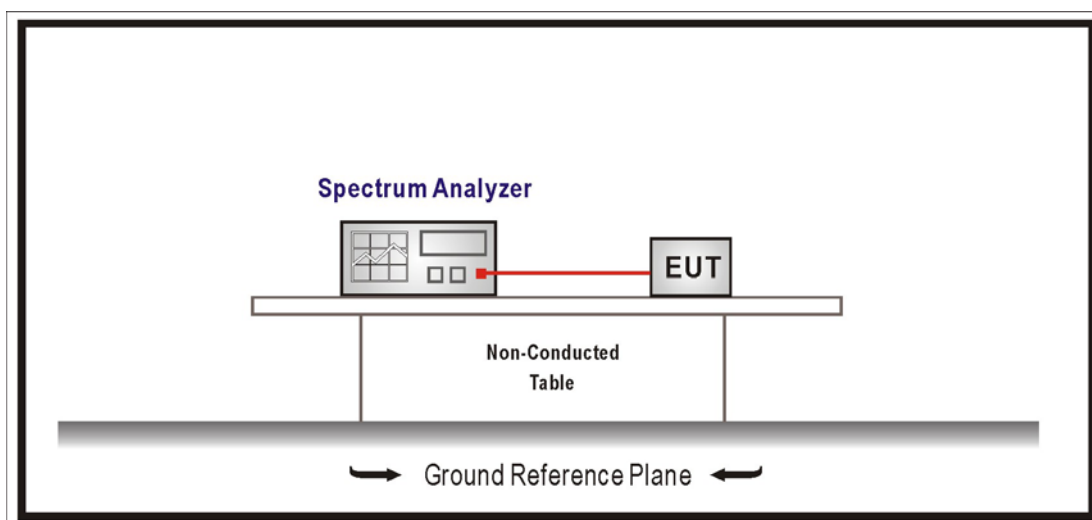

10.3. Limits

For frequency hopping systems operating in the 902-928 MHz band: if the 20 dB bandwidth of the hopping channel is less than 250 kHz, the system shall use at least 50 hopping frequencies and the average time of occupancy on any frequency shall not be greater than 0.4 seconds within a 20 second period; if the 20 dB bandwidth of the hopping channel is 250 kHz or greater, the system shall use at least 25 hopping frequencies and the average time of occupancy on any frequency shall not be greater than 0.4 seconds within a 10 second period. For frequency hopping systems operating in the 2400-2483.5 MHz bands. The average time of occupancy on any channel shall not be greater than 0.4 seconds within a period of 0.4 seconds multiplied by the number of hopping channels employed. For frequency hopping systems operating in the 5725-5850 MHz bands. The average time of occupancy on any frequency shall not be greater than 0.4 seconds within a 30 second period.

10.4. Test Procedures

The EUT was setup according to ANSI C63.10:2013 and tested according to FHSS test procedure of FCC Public Notice DA 00-705 for compliance to FCC 47CFR 15.247 requirements

Span = zero span, centered on a hopping channel , RBW = 1 MHz, VBW \geq RBW ,
Sweep = as necessary to capture the entire dwell time per hopping channel ,
Detector function = peak, Trace = max hold.

10.5. Test Specification

According to FCC Part 15 Subpart C Paragraph 15.247: 2015

10.6. Test Result

Product	Multimedia System		
Test Item	Dwell Time		
Test Mode	Mode 1: Transmit		
Date of Test	2017/09/27	Test Site	SR10-H

GFSK, DH5

Occupancy Time of Frequency Hopping System

A) 2402MHz Test Time Period: $0.4 \times 79 = 31.60 \text{ sec}$, Time slot length : 2.894 ms = 0.002894 sec

Dwell Time : 0.002894 * (266.67/79) * 31.60 = 0.3087 sec ◦

B) 2441MHz Test Time Period: $0.4 \times 79 = 31.60 \text{ sec}$, Time slot length : 2.896 ms = 0.002896 sec

Dwell Time : 0.002896 * (266.67/79) * 31.60 = 0.3089 sec ◦

C) 2480MHz Test Time Period: $0.4 \times 79 = 31.60 \text{ sec}$, Time slot length : 2.893 ms = 0.002893 sec

Dwell Time : 0.002893 * (266.67/79) * 31.60 = 0.3086 sec ◦

Test Result: The Average Occupancy Time of Each Highest , Middle and Lowest Channel Is Less Than 0.4sec , And Corresponds to The Standard ◦

Hop rate-2402MHz

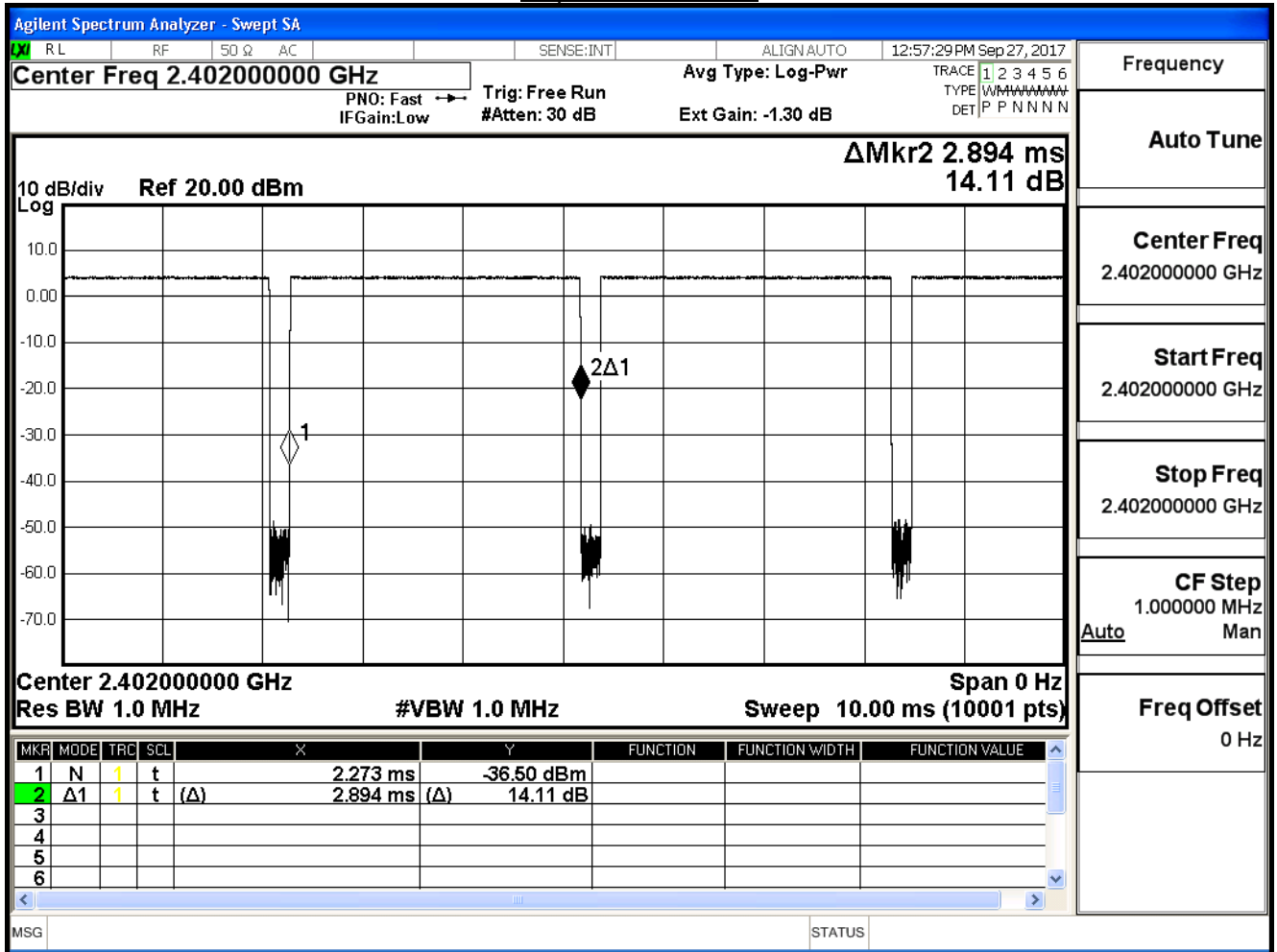

Hop rate-2441MHz

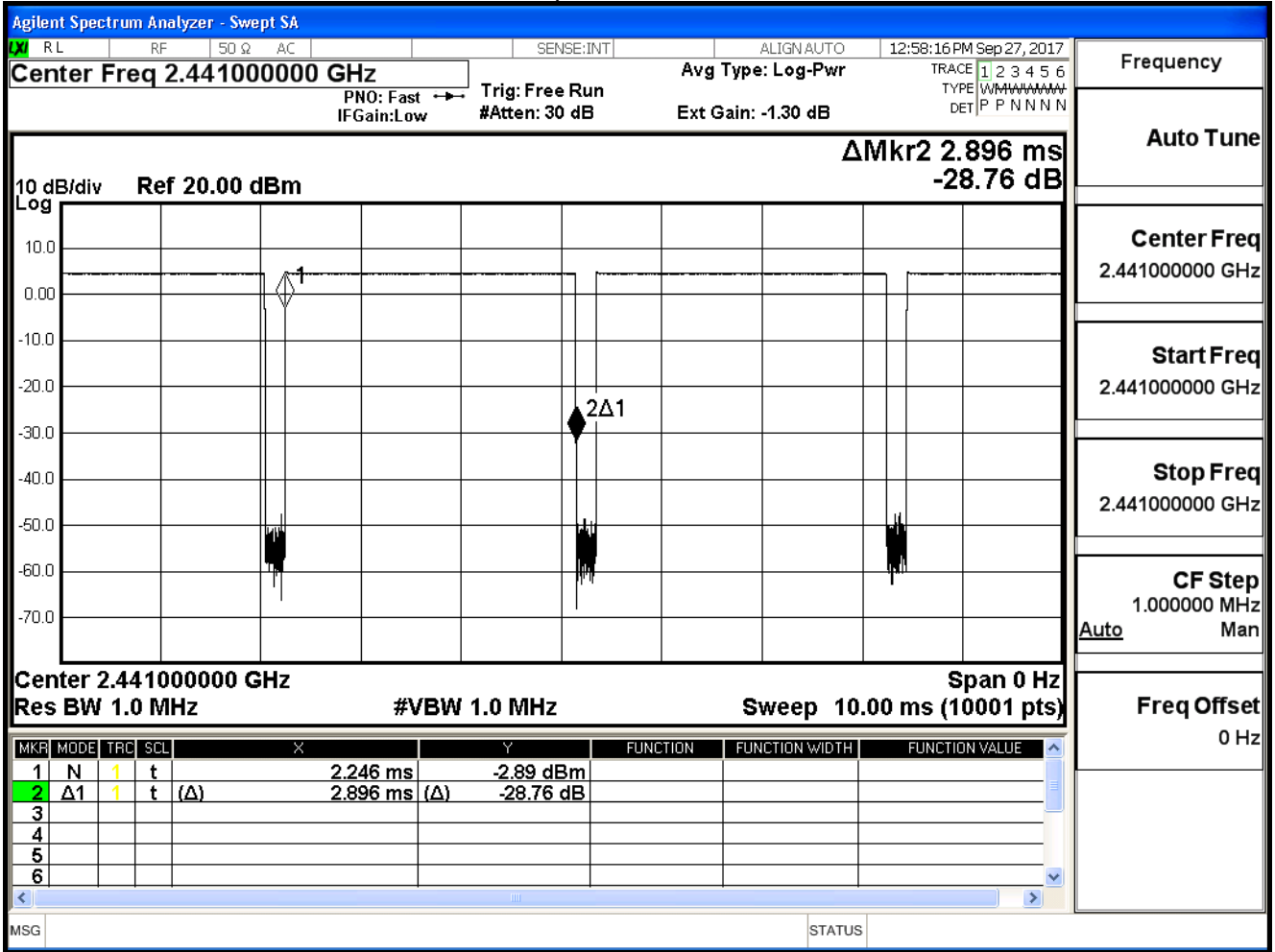

Hop rate-2480MHz

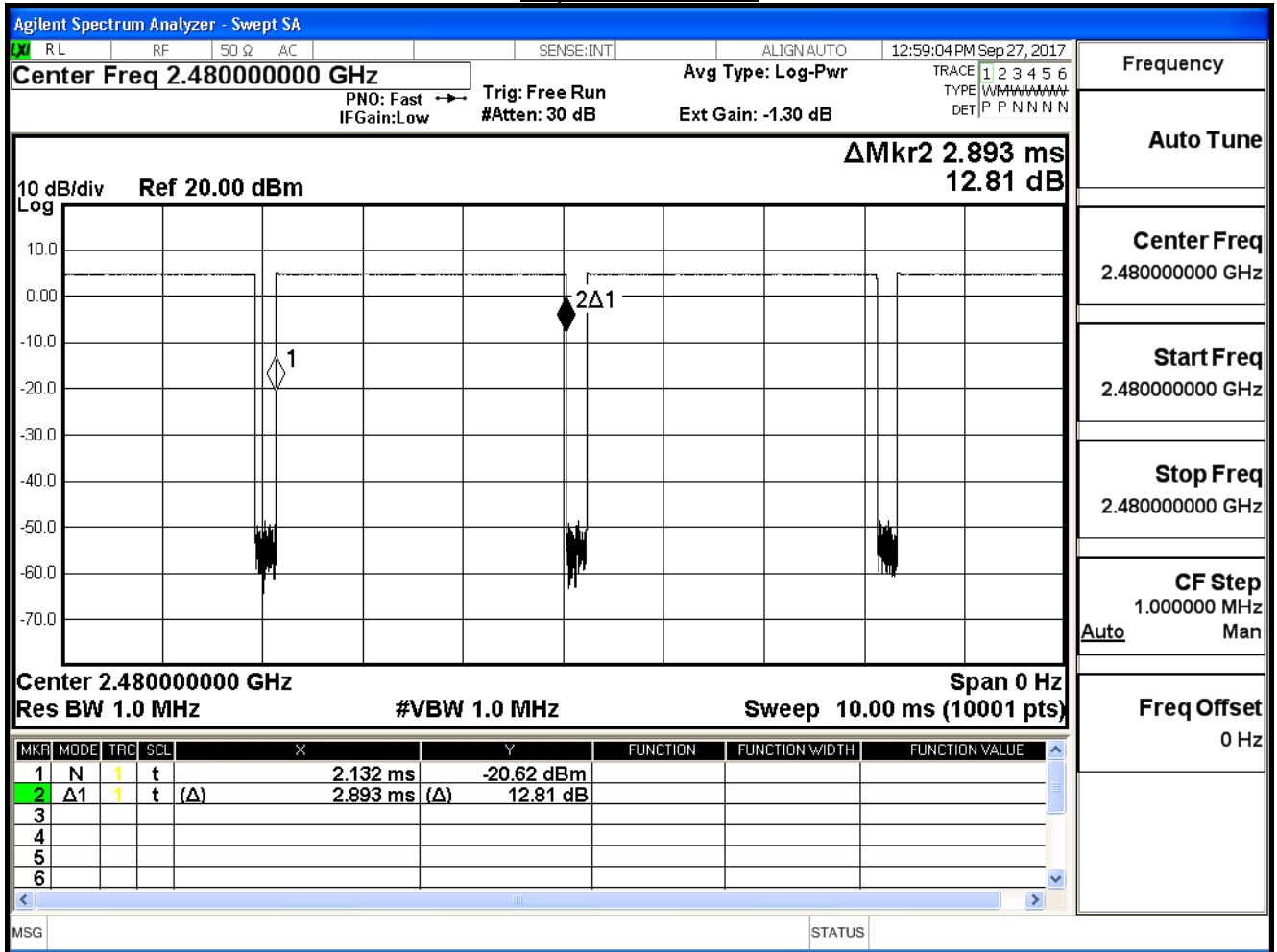

Note: Dwell time = time slot length * hop rate / number of hopping channels * period

Product	Multimedia System		
Test Item	Dwell Time		
Test Mode	Mode 1: Transmit		
Date of Test	2017/09/27	Test Site	SR10-H

$\pi/4$ -DQPSK, 2DH5

Occupancy Time of Frequency Hopping System

A) 2402MHz Test Time Period: $0.4 \times 79 = 31.60 \text{ sec}$, Time slot length : 2.904 ms = 0.002904 sec
 Dwell Time : 0.002904 * (266.67/79) * 31.60 = 0.3098 sec ◦

B) 2441MHz Test Time Period: $0.4 \times 79 = 31.60 \text{ sec}$, Time slot length : 2.901 ms = 0.002901 sec
 Dwell Time : 0.002901 * (266.67/79) * 31.60 = 0.3094 sec ◦

C) 2480MHz Test Time Period: $0.4 \times 79 = 31.60 \text{ sec}$, Time slot length : 2.903 ms = 0.002903 sec
 Dwell Time : 0.002903 * (266.67/79) * 31.60 = 0.3097 sec ◦

Test Result: The Average Occupancy Time of Each Highest , Middle and Lowest Channel Is Less Than 0.4sec , And Corresponds to The Standard ◦

Hop rate-2402MHz

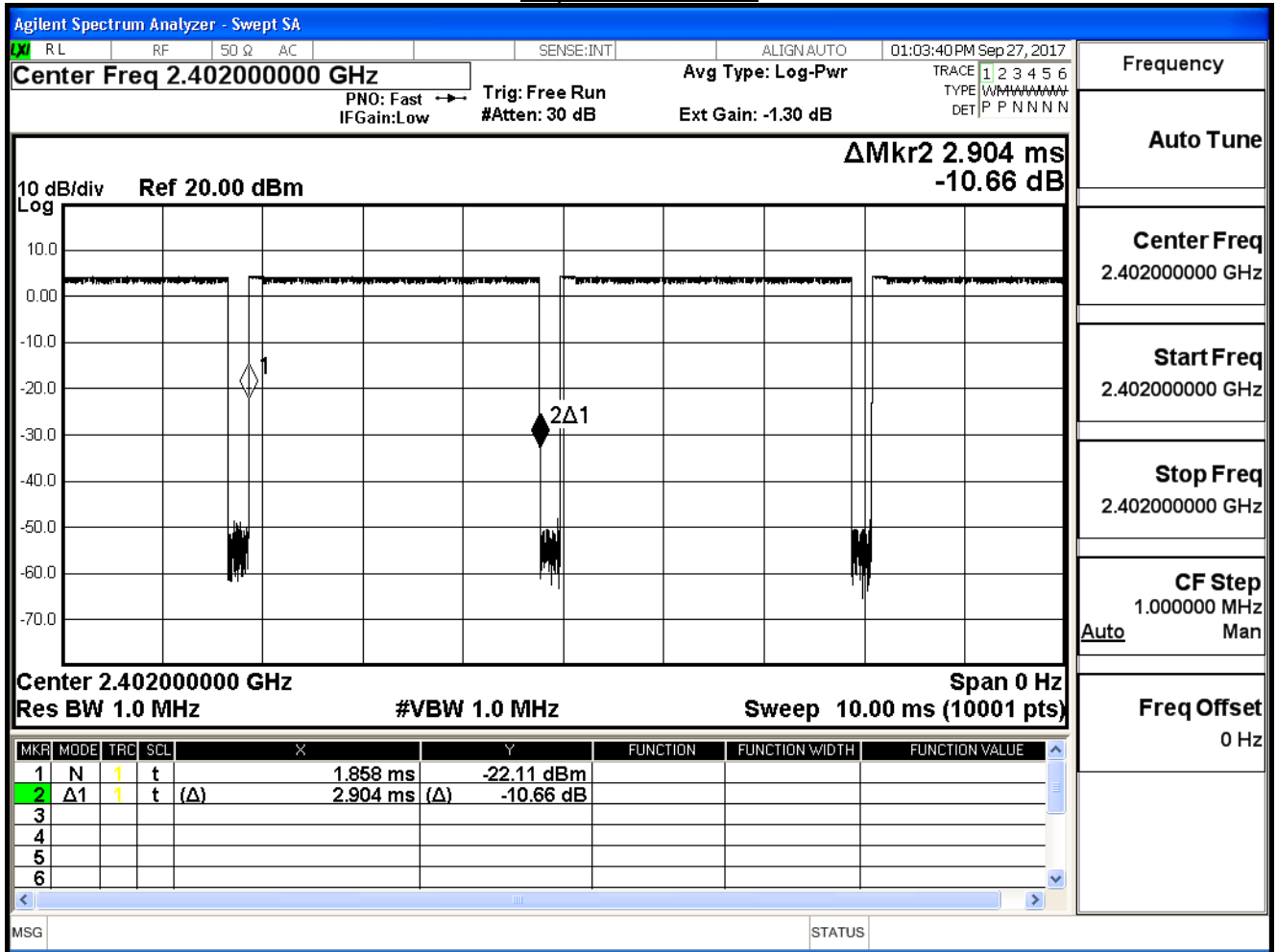

Hop rate-2441MHz

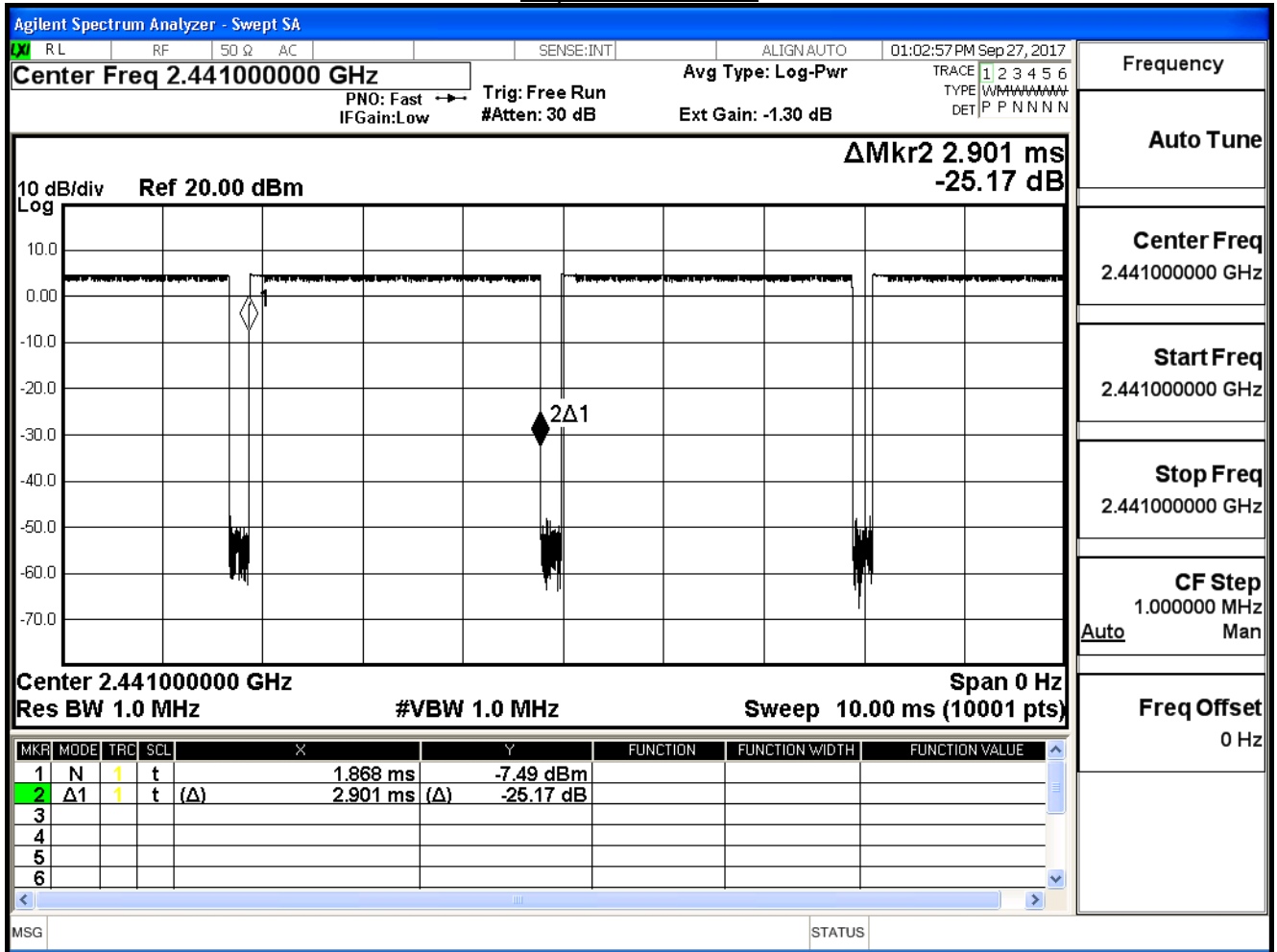

Hop rate-2480MHz

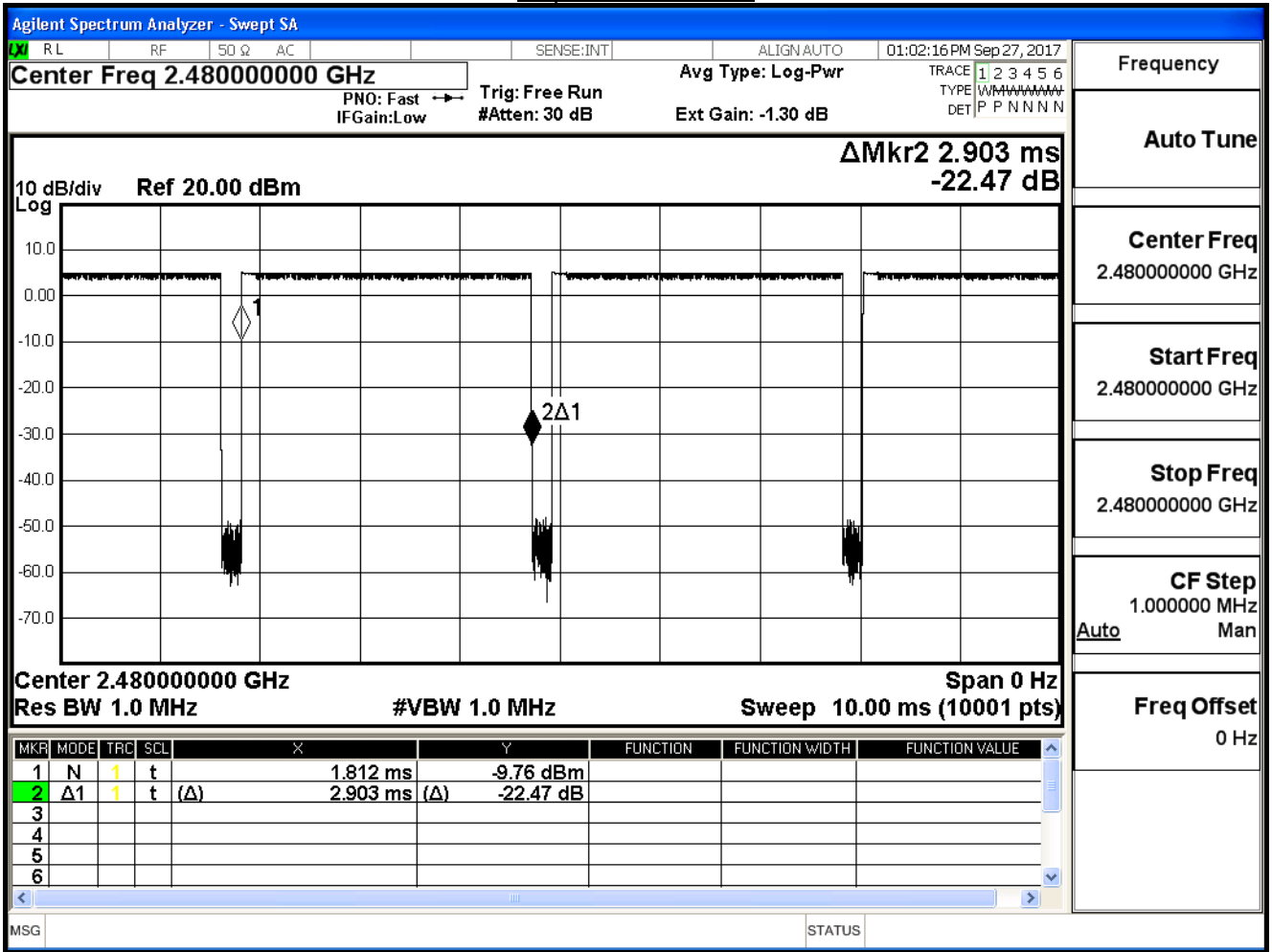

Note: Dwell time = time slot length * hop rate / number of hopping channels * period

Product	Multimedia System		
Test Item	Dwell Time		
Test Mode	Mode 1: Transmit		
Date of Test	2017/09/27	Test Site	SR10-H

8-DPSK, 3DH5

Occupancy Time of Frequency Hopping System

A) 2402MHz Test Time Period: $0.4 \times 79 = 31.60 \text{sec}$, Time slot length : 2.902ms = 0.002902 sec

Dwell Time : $0.002902 \times (266.67/79) \times 31.60 = 0.3096$ sec ◦

B) 2441MHz Test Time Period: $0.4 \times 79 = 31.60 \text{sec}$, Time slot length : 2.904 ms = 0.002904 sec

Dwell Time : $0.002904 \times (266.67/79) \times 31.60 = 0.3098$ sec ◦

C) 2480MHz Test Time Period: $0.4 \times 79 = 31.60 \text{sec}$, Time slot length : 2.904 ms = 0.002904 sec

Dwell Time : $0.002904 \times (266.67/79) \times 31.60 = 0.3098$ sec ◦

Test Result: The Average Occupancy Time of Each Highest , Middle and Lowest Channel Is Less Than 0.4sec , And Corresponds to The Standard ◦

Hop rate-2402MHz

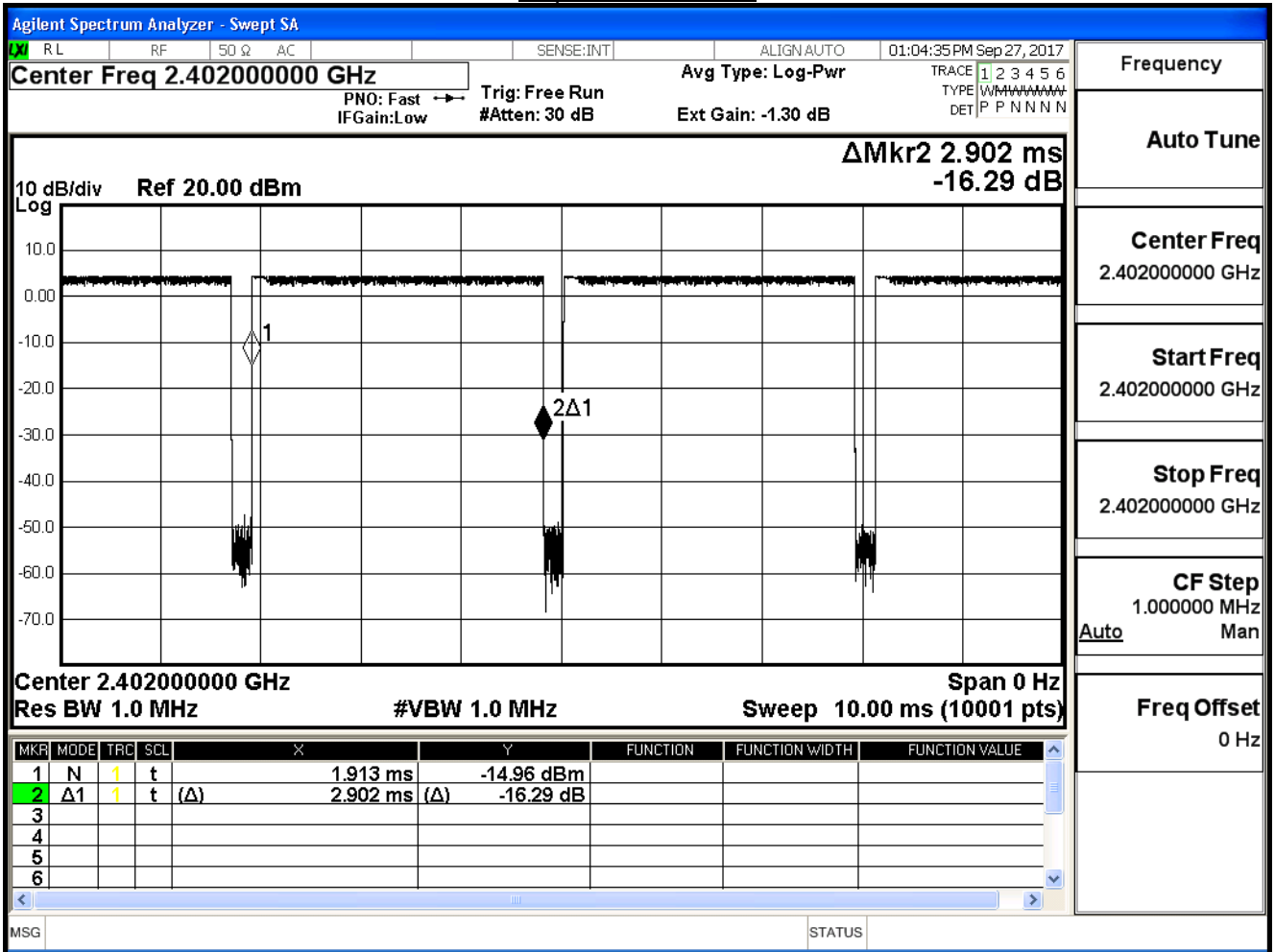

Hop rate-2441MHz

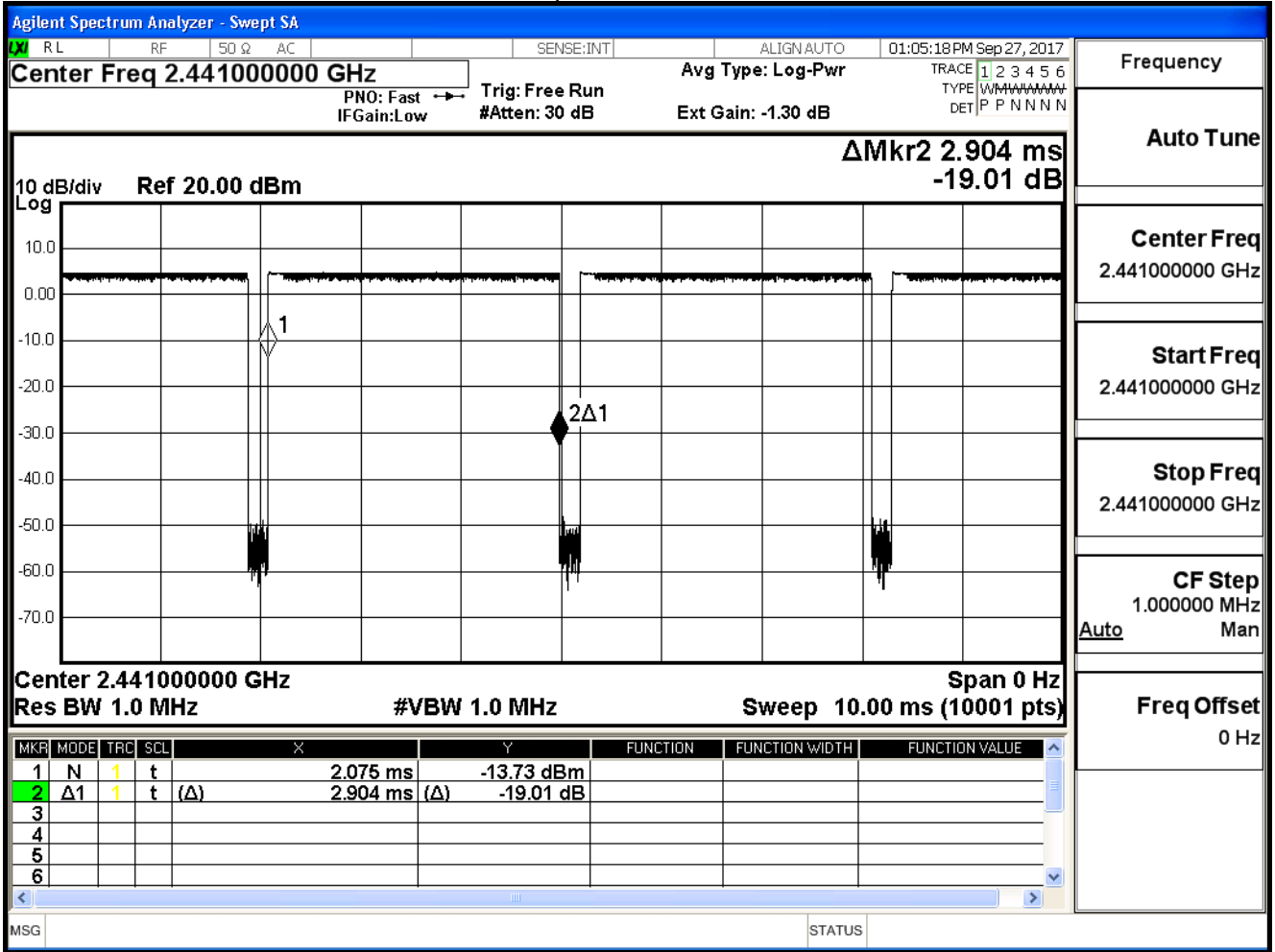

Hop rate-2480MHz

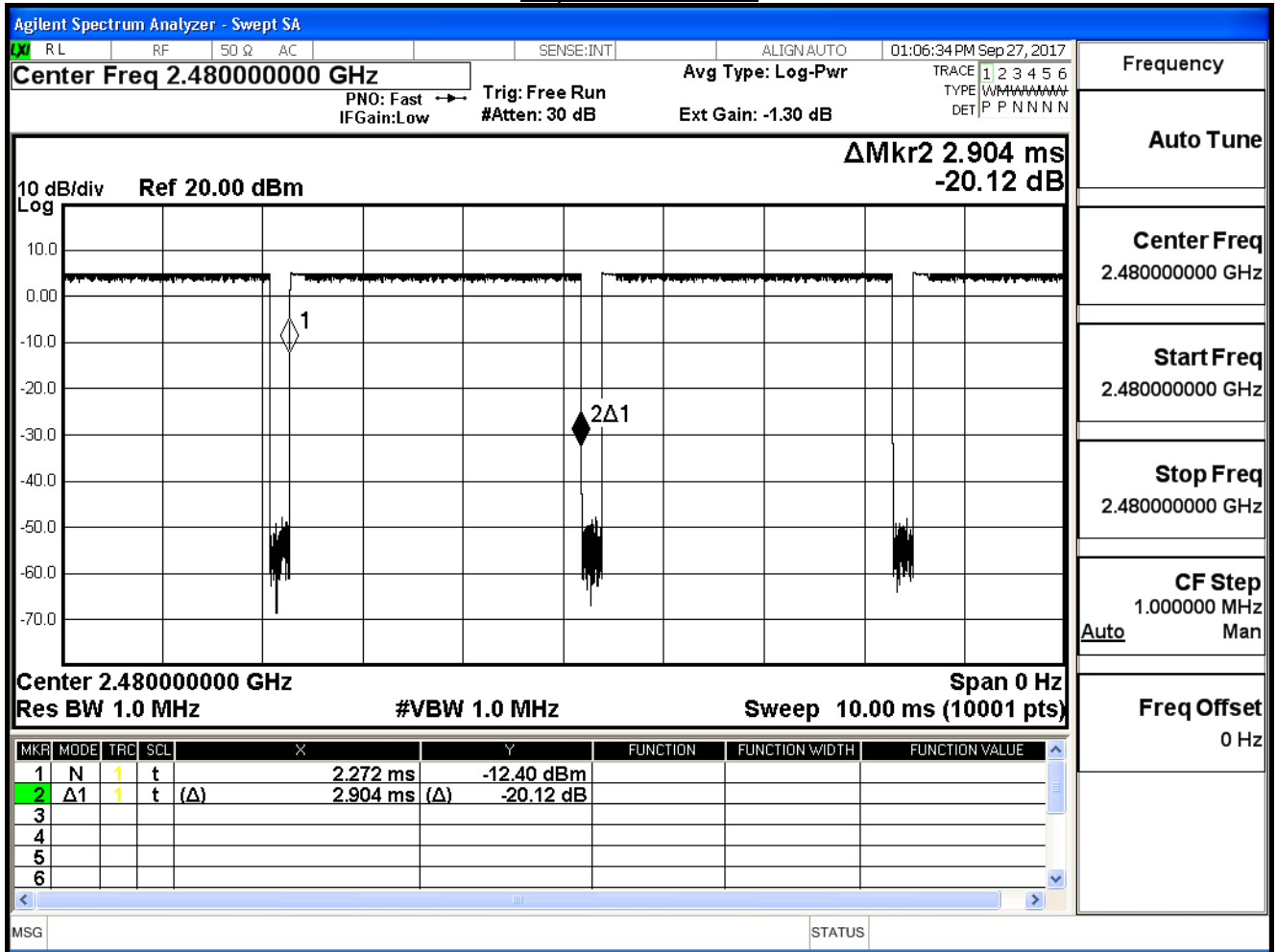

Note: Dwell time = time slot length * hop rate / number of hopping channels * period