



SPECIFICATION OF APPROVAL

Customer : _____

Product Model : **ST-IWCBM**Description : **7.5W/10W Wireless Charger**Sample Date: **2018-07-10**

APPROVAL

Checked & Approved by

Prepare By

QC

Date

CUSTOMER APPROVAL

Engineering

Quality Assurance

Other

Note:

1. Kindly please sign on the above and send it back to us if the sample is approve
2. Kindly please contact us as soon as possible if the sample isn' t approved. Thanks!

Result: Accept Reject Other

History of revisions

Edition	Date	Detail	By
V1.0	2018-08-21	Initial release	Barry Song

Gopod Group Holding Limited

Add.: 4-6/F, Building 8, Lian Jian Industrial Park, Huarong Road, Dalang, Longhua, Shenzhen, China.

TEL : 0755-82807722 , FAX : 0755-82807700

Web: www.Gopod.cc



Contents

- 一、Product & Accessory.....
- 1.1 Product Introduction
- 1.2 Accessory List
- 二、Electrical Specification
- 三、Functional Description.....
- 3.1 Outlook & Interface.....
- 四、Working Condition.....
- 4.1 Temperature & Humidity.....
- 五、FCC STATEMENT

一、Product & Accessory

Product Introduction

- GW13S is a wireless charger that can provide fast charging if it's connected with QC2.0 or QC3.0/PD2.0/3.0 adapter. The single coil is made with 10W fixed frequency, so the product can be compatible with 5W, 7.5W and 10W, and then wireless charging every Qi device, such as iPhone 8, iPhone 8Plus, iPhoneX and Samsung S9 and so on.

Accessory List

- GW13S 1pcs
- Manual 1pcs
- Product size: 100mm*100mm*11.5mm

二、Electrical Specification

Qi Output characteristic

- 2.2.1 Load rated output voltage: Vdc4.75-5.4V@8.55-9.45V
- 2.2.2 Load rated output current: 1100mA
- 2.2.3 5V rated output working efficiency: 68%
- 2.2.4 9V rated output working efficiency: 72%
- 2.2.5 Mobile phone contact surface temperature: 40°C
- 2.2.6 Operating frequency: 127.7kHz±6HZ
- 2.2.7 The housing surface: Stop charging if temperature is over 45°C±5°C
- 2.3.8 Dynamic power control: Vdc 4.7V
- 2.3.9 Over-temp protection: When internal temperature reaches 60°C

三、Functional Description

3.1 Outlook & Interface

Outlook and interface of ST-IWCBM as picture shown below

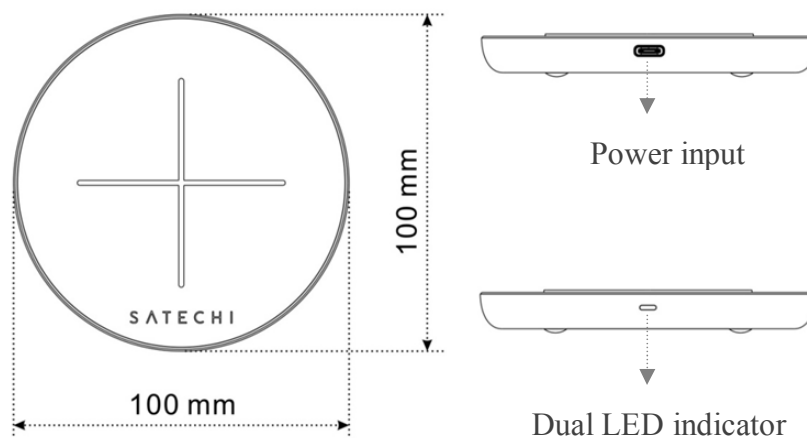

Diagram 1

Outlook & interface functional description

SN	Instruction	Functional description
A	Power input	Type C 5V/9V&2A@ QC2.0/3.0/PD2.0/PD3.0
B	Dual LED indicator	Working power indicator light

4.3 Product Connection Diagram

ST-IWCBM connected with iPhone X and wireless charging, Diagram 1



四. Working Condition

5.1 Temperature & Humidity:

Item	Working condition	Storage condition:	Remark
Temp:	0°C-40°C	-20°C-55°C	
Humidity:	0% -90%(without dew)	20% -95%(without dew)	
Atmospheric pressure:	80-106KPa	80-106KPa	



五. FCC STATEMENT

This device complies with Part 15 of the FCC Rules. Operation is subject to the following two conditions:

- (1) This device may not cause harmful interference, and
- (2) This device must accept any interference received, including interference that may cause undesired operation.

Warning: Changes or modifications not expressly approved by the party responsible for compliance could void the user's authority to operate the equipment.

NOTE: This equipment has been tested and found to comply with the limits for a Class B

digital device, pursuant to Part 15 of the FCC Rules. These limits are designed to provide reasonable protection against harmful interference in a residential installation. This equipment generates uses and can radiate radio frequency energy and, if not installed and used in accordance with the instructions, may cause harmful interference to radio communications. However, there is no guarantee that interference will not occur in a particular installation. If this equipment does cause harmful interference to radio or television reception, which can be determined by turning the equipment off and on, the user is encouraged to try to correct the interference by one or more of the following measures:

Reorient or relocate the receiving antenna.

Increase the separation between the equipment and receiver.

Connect the equipment into an outlet on a circuit different from that to which the receiver is connected.

Consult the dealer or an experienced radio/TV technician for help.

FCC Radiation Exposure Statement:

This equipment complies with FCC radiation exposure limits set forth for an uncontrolled environment. This equipment should be installed and operated with minimum distance 20cm between the radiator & your body.