

## Salt Water Spray Test

		3 : 1 or less @ 133KHz		
		Before Test	After Test	Rate of Change
Outdoor LF Antenna	#13	1.62	1.56	-3.70%
	#14	1.36	1.28	-5.88%
	#15	1.39	1.33	-4.32%
	#16	1.47	1.37	-6.80%
	#17	1.41	1.38	-2.13%
	#18	1.34	1.31	-2.24%
	VSWR	OK		

Test Image





## **8. Precaution**

### **8.1 Storage**

Store products away from hot or humid places

Store the product away from corrosive gases such as hydrogen sulfide, sulfuric acid, chlorine, ammonia, etc

### **8.2 Storage Conditions**



Temperature : 5 to 35°C

Humidity : 45 to 75% RH

Period : 4 Months from the date of Packaging

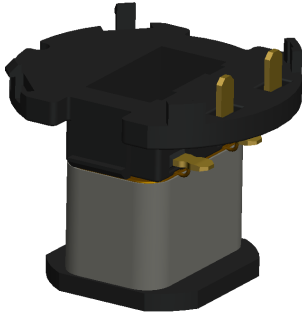
# Product Approval Sheet

<b>Product Name</b>	<b>ANTENNA,LF: ASSY SSB(133KHz)</b>	<b>Product Image</b>
<b>Model</b>	<b>SSB LF Antenna</b>	
<b>Part No.</b>	<b>1-3602-00009</b>	
<b>Manufacturer</b>	<b>RF Controls Co. Ltd</b>	

DESIGN	CHECK	APPROVAL
		
2019.02.01.	2/1	

# **Contents**

- 1. Revision History**
- 2. Product Description**
- 3. Rated Specifications**
- 4. Drawing**
- 5. Related Standards**
- 6. Reliability Test**
- 7. Packaging Specifications**
- 8. Precaution**

## 1. Revision History

Rev.	Contents	Description	Organization	Date
0	Production Release			
1	Resonance Frequency change (134KHz -> 133KHz)	Re-Approval	R&D Team	Immediately
2				
3				
4				

## 2. Product Descriptions

### 2.1 Outlines

#### 2.1.1 Product Name

ANTENNA,LF: ASSY SSB(133KHz)

#### 2.1.2 Goal

This product is mounted inside the heavy equipment of Doosan Infracore and is used to communicate with the smart key of the user inside the vehicle. It also functions to exchange authentication signals with adjacent smart keys when an emergency start is required when the battery of the smart key is discharged.

### 2.2 Application Range

Excavator / Wheel Loader

### 2.3 Warranty

1 Year

### 3. Rated Specifications

#### 3.1 Environment and Operation

Environmental & Operation Specification		
No	Parameter	Specification
1	Storage Temperature	-40°C to 105°C
2	Operation Temperature	-30°C to 85°C

#### 3.2 Electrical

Electrical Specification		
No	Parameter	Specification
1	Resonance Frequency	133KHz $\pm$ 5%
2	Inductance	172uH $\pm$ 5%
3	VSWR	3 : 1 or less @ 133KHz

### 3.3 Components

#### 3.4.1 Body Antenna Assembly

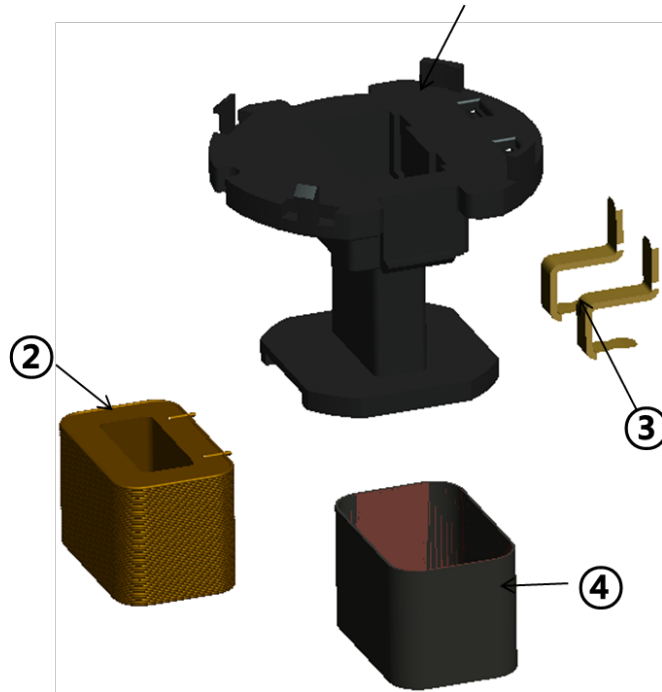

PART DESCRIPTION				
No	P/No	P/Name	Q'ty	Remark
1	0000525	SSB HOUSING	1	
2	0000521	COIL	1	
3	0000526	TERMINAL B	2	
4	0000561	INSULATED TAPE	1	



# 4. Drawing

## 4.1 Mechanical Drawing

### 4.1.1 SSB LF Antenna Assembly

ISO VIEW  
(Do not scale)

**1. Electrical Specifications**

Electrical Specification	
NO	Specification
1	Resonance Frequency 1330± 5%
2	Inductance 170.4 ± 5% @ 20Hz
3	VSWR 3.1 or less @ 1330Hz

**2. Environment and Operation**

Environmental & Operation Specification	
NO	Specification
1	Storage Temperature -40°C to 125°C
2	Operation Temperature -30°C to 85°C

**3. Reliability Test**

Standards	Test Title	Test Method	Requirement
Electromagnetic parts Environmental Test	1	Low Temperature Test	After completion of the test, the change in the performance value of the DUT is within 10%
	2	High Temperature Test	After completion of the test, the change in the performance value of the DUT is within 10%
		Temperature Cycle Test	After completion of the test, the change in the performance value of the DUT is within 10%

**NOTE**

- There should be no flow, noise, or eccentricity after assembling with the counterpart assembly
- The reliability test specifications and items comply with the customer request test procedure
- Complies with MSDS/ROHS regulations on the use of harmful substances in the environment
- Be careful of deformation when handling products

**PARTLIST**

NO	PART NAME	Material
①	ANTENNA ASSEMBLY	A1F Z31
②	COIL	ZULEW #03
③	TERMINAL B	C280(SH)
④	SSB HOUSING	9466-GF30 BLACK (U158-V0)

2023.11.08	Resonance Temperature Change	MHC	KWK
2023.02.24	Production Release	MHC	KWK

2023.11.08	1-1	SEE TABLE	1-1	SEE TABLE	1-1	SEE TABLE
2023.11.08	1-1	SEE TABLE	1-1	SEE TABLE	1-1	SEE TABLE
2023.11.08	1-1	SEE TABLE	1-1	SEE TABLE	1-1	SEE TABLE

2023.11.08	1-1	SEE TABLE	1-1	SEE TABLE	1-1	SEE TABLE
2023.11.08	1-1	SEE TABLE	1-1	SEE TABLE	1-1	SEE TABLE
2023.11.08	1-1	SEE TABLE	1-1	SEE TABLE	1-1	SEE TABLE

2023.11.08	1-1	SEE TABLE	1-1	SEE TABLE	1-1	SEE TABLE
2023.11.08	1-1	SEE TABLE	1-1	SEE TABLE	1-1	SEE TABLE
2023.11.08	1-1	SEE TABLE	1-1	SEE TABLE	1-1	SEE TABLE

**RF CONTROLS**

## 5. Related Standards

### 5.1 Environmental Test

Item	Division	Test Title	Q'ty	Test Condition	Requirement
Common	Performance Test	Basic Function Test	12	Performance Test after connecting test Jig	Check Specification
SSB LF Antenna	Environmental Test	Low Temp. Test	6	Proceed at $-40\pm 2^{\circ}\text{C}$ for 100 hours and leave at room temperature for 2hrs	After completion of the test, the change in the performance value of the DUT is within 10%
	Environmental Test	High Temp. Test	6	Proceed at $+85\pm 2^{\circ}\text{C}$ for 100 hours and leave at room temperature for 2hrs	After completion of the test, the change in the performance value of the DUT is within 10%

## 6. Reliability Test

### 6.1 Environmental Test Results

Low Temperature Test		S i g n	Design	Check	Check	Approval
			J.H. Ko			W.K. Kim
Report No.	RFC-0104-005	Date	2019.01.04			
Test Date	2018.12.27~2018.12.31	Organization/Tester	R&D Team / J.H. Ko			
<b>1. General Status</b>						
Request Team	RFC Co. Ltd R&D Team	Purpose	Reliability Test			
Requester	J.H. Ko	Test Item	low Temperature Test			
<b>2. Test Target</b>						
Car	Wheel Loader/ Excavator	Part No.	1-3602-00009			
Model	ANTENNA,LF:ASSY SSB (133KHz)	LOT NO.	#1 ~ #6			
<b>3. Test Status</b>						
Management No.	RFC-0104-005	Test Equipment	Constant Temp. Chamber			
Test Site	RF Controls Co. Ltd	Number of Samples	6 EA			
<b>4. Test Methods and Criteria</b>						
Test Method	Proceed at $-40\pm 2^{\circ}\text{C}$ for 100 hours and leave at room temperature for 2hours					
Criteria	▶ After completion of the test, the change in the performance value of the DUT is within 10%					
<b>5. Test Results : " PASS " (Refer: Attached DATA)</b>						
<b>6. Remarks</b> - Reliability Test						
※ This is a test report only for samples submitted by the above request team and cannot be used for propaganda, litigation, or other legal requirements						