

User Manual-Smart Tag Location	Version:	1.6	
	Date:	07-04-14	
	Page:	1 of 12	

User Manual-Smart Tag Location

[Not Set]

Date:	07-04-14
Version:	1.6

Owned by:	Richard Watson	Mechanical Engineer
Prepared by:	Richard Watson	Mechanical Engineer
Checked by:	Vishal Nayar	Business Development Director
Approved by:	Charles Lewinton	Head Of Engineering

The material contained in this document may not be copied, published, transmitted, reproduced or disclosed, in whole or in part without the prior written permission of buddi Ltd.

DOCUMENT HISTORY

Version	Date	Author	Description
1.0	07-04-14	R.Watson	Initial Issue
1.1	17-04-14	R.Watson	Corrections and edits by S.Campfield
1.2	03-06-14	R.Watson	FCC Warning Statement Added
1.3	30-07-14	R.Watson	SAR Test Added to FCC Warning Statement
1.5	08-07-14	C Lewniton	Added IC warning statement

REFERENCED DOCUMENTS

Ref.	Document Name	Version	Date

CONTENTS

- 1. Introduction..... 4
- 2. Equipment Description..... 4
- 3. Smart Tag Fitting 5
- 4. Smart Tag Operation 6
- 5. Smart Tag Removal..... 6
- 6. On Body Charger 7
- 7. Sanitization and Re-Use 9
 - 7.1. Smart Tag 9
 - 7.1.1. Collection..... 9
 - 7.1.2. Inspection 9
 - 7.1.3. Cleaning 9
 - 7.2. Smart Tag Strap 10
 - 7.2.1. Collection..... 10
 - 7.2.2. Inspection 10
 - 7.2.3. Cleaning 10
 - 7.3. OBC..... 11
 - 7.3.1. Collection..... 11
 - 7.3.2. Inspection 11
 - 7.3.3. Cleaning 11
- 8. FCC warning statement 12
- 9. IC Warning Statement 12

1. Introduction

This document is intended to be the source reference material for using the Smart Tag product, with the exception of electronic configuration (including set-up and interaction with the on-line monitoring portal). The emphasis here is upon describing the physical features, charging, correct fitting and removal etc.

2. Equipment Description



- a) Smart Tag- Ankle worn electronic monitoring device. One is required per subject.
- b) Smart Tag Strap- For securing the Smart Tag to a subject. One is required per subject, the strap is available in a number of sizes in order to accommodate ankles.
- c) On Body Charger- One is required per subject, for recharging the on-board battery.
- d) Locking Plate- Two Locking plates are required per Smart Tag. The locking plates will be damaged upon removal of the Strap, therefore new locking plates must be installed in the Smart Tag before it can be fitted to a new Subject.

e) Removal Tool- One is required to release the strap and remove the Smart Tag from the subject. It punctures very small holes in a very controlled location on the Locking Plates and releases the strap. Not shown above.

3. Smart Tag Fitting

The Smart Tag should be prepared for fitting to the subject by clipping two new Locking Plates in position as shown below in red for clarity.



The Locking Plates will be secured in position when the Strap is inserted into the Smart Tag, they protect the strap from being released without physical damage being created for evidence gathering purposes.

Measure around the ankle, holding the measuring tape loosely. Record the measure in millimetres (mm).



Using the strap sizing reference material select the strap size recommended for the subjects ankle measurement.

Fit the Strap into the Smart Tag at one side, then wrap around the ankle of the subject ensuring the arrow on the front surface is pointing upwards, and connect the free end of the Strap into the Smart Tag. A clear 'click' will be heard as the Strap securely engages inside the Smart Tag, it should be possible to slip two fingers behind the strap to ensure enough movement for cleaning, charging and general comfort.

User Manual-Smart Tag Location	Version:	1.6	
	Date:	07-04-14	
	Page:	6 of 12	

The fitting of the strap will create a closed optical circuit which is continuously monitored by the Smart Tag.

4. Smart Tag Operation

The Smart Tag communicates via GSM to a server based monitoring platform, which interprets the data provided to populate a web portal user interface. The data sets include the following:

- Event Time.
- GPS Location (Intervals can be defined, or a real-time request made).
- Geofence Data (Virtual zones for inclusion or exclusion set by map data).
- Position Type (GPS, RF Beacon).
- Speed of Motion.
- Battery Level.
- Charger On / Off.
- Signal Strength.
- Strap On / Off (Off includes tampering or cutting).
- Alerts (Based upon one or more of the above).

Alerts can take the form of notifications within the web portal, by e-mail, SMS to mobile phone notifications or vibration feedback within the Smart Tag on the subject.

When in proximity to an RF Beacon, the Smart Tag will not attempt to achieve new GPS fixes, resulting in significantly less demand on battery power.

5. Smart Tag Removal

Note any obvious sign of damage to the Smart Tag, or Strap in accordance with local protocol.

When removing the Smart Tag from a subject protective gloves should be worn.

Check that the locking plates are complete, correctly located and undamaged. If locking plates are damaged, follow local protocol which may include cutting the strap and retaining evidence if necessary.

With no locking plate damage, use the removal tool to release the strap at one end.

Using the release tool, engage the plastic jaws over the Smart Tag and begin to squeeze the handles together. The jaws will self-locate to the correct position and the release pins will puncture the Locking Plate, continue to squeeze until the Strap is released. Only one end of the Strap will be released, this is indicated by the red markers on the end of the release pins.



6. On Body Charger

The Smart Tag on-board battery will require recharging at intervals consistent with the operating mode being used. It is intended that the OBC is connected to a mains power supply when not in use, to charge up the device in preparation for connection to the Smart Tag, to fully charge the OBC it should be connected for 4 hours.

In cases where the OBC has not been charged prior to use it is possible to attach the unit to the Smart Tag with the OBC connected directly to the mains power supply, however this is not recommended practice – although a break-away extender cable is provided for such circumstances. The OBC will fully charge the Smart Tag in less than 2 hours.

The equipment is attached to the Smart Tag for charging in a secure manner by locating the OBC over the unit and closing the sliding clip, so as to allow free movement of the wearer and continuous electrical contact. This only requires a hand operated force which is deemed 'reasonable' and 'convenient' to the wearer. The attachment clip is capable of being attached and removed repeatedly, the number of cycles will comfortably exceed the lifetime of the product. The mass of the OBC is 240g.





The On Body Charger fits correctly in one orientation with the LED indicators facing upwards, to inform the subject of the charging status.

The status LED's provide the following information:

- Charging from mains power;
- Fully charged;
- Charging the Smart Tag;
- Smart Tag fully charged.

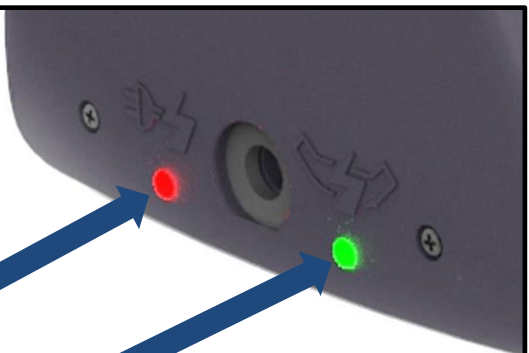

Mains Indication:

Red Light =Charging from Mains

Green Light =Fully Charged

Off =Not Connected to Mains

Charging Indicator:

Red Light Flashing =Charging Smart Tag

Green Light Flashing =Charging of Smart Tag Complete

© buddi Ltd 2012 e WD3 1DE.

User Manual-Smart Tag Location	Version:	1.6	
	Date:	07-04-14	
	Page:	9 of 12	

7. Sanitization and Re-Use

7.1. Smart Tag

7.1.1. Collection

The Smart Tag will be removed as per the removal process above.

- Place the Smart Tag and strap into a clean plastic bag and return them to the vehicle for inspection and cleaning.

7.1.2. Inspection

The Smart Tag should be inspected for signs of damage, units with damage should be dealt with in accordance with local protocols. Damage includes any significant surface marking which may be indicative of the unit being exposed to high impacts or tampering. Special care should be taken to ensure the following areas are inspected;

- Any seam between plastic casings, damage here may indicate the sealing surfaces of the unit are damaged.
- The inside surfaces of the strap acceptance area. The unit should be returned for testing if there is any sign of wear in this area.

7.1.3. Cleaning

If there is any heavy soiling or biological matter on the unit that is unlikely to be easily removed by a sanitising wipe, then the unit should be cleaned thoroughly in line with local protocol.

To sanitise a Smart Tag in the field the following process should be followed;

- Wear gloves.
- Using the removal tool, release the Smart Tag from the Strap and remove the locking plates.
- Wrap the unit in an approved sanitising wipe.
- Rub the unit vigorously with the wipe ensuring all surfaces receive a good covering of alcohol.
- Wrap the unit in a new wipe and place in a sealed plastic bag for at least one minute.
- Remove the unit from the bag, dispose of the wipe and allow the unit to dry in a well-ventilated area.

The unit can then be returned to stock for re-use.

User Manual-Smart Tag Location	Version:	1.6	
	Date:	07-04-14	
	Page:	10 of 12	

7.2. Smart Tag Strap

7.2.1. Collection

When handling the Strap protective gloves should be worn.
The strap will be freed from the Smart Tag as part of the Smart Tag Removal process above.

7.2.2. Inspection

The Strap should be inspected for signs of damage, straps with damage should be dealt with in accordance with local protocols. Damage includes any significant surface marking which may be indicative of the unit being exposed to high impacts or tampering. Special care should be taken to inspect the following areas;

- The flexible strap material, both inner and outer most surfaces.
- All visible surfaces of plastic, particularly the join between the flexible and rigid sections. Damage in this area could be indicative of tampering and may adversely affect the future performance of the device.
- The tongue area that engages with the Smart Tag, particularly the locking clips. Damage or excessive wear in this area could affect the future performance of the device.
- Debris, soiling or damage to the optical end of the strap.

7.2.3. Cleaning

If there is any heavy soiling or biological matter on the unit that is unlikely to be easily removed by a sanitising wipe, then the unit should be cleaned thoroughly in line with local protocol.

To sanitise a Strap in the field the following process should be followed;

- Wear gloves.
- Wrap the strap in an approved sanitising wipe.
- Rub the strap vigorously with the wipe ensuring all surfaces receive a good covering of alcohol.
- Wrap the strap in a new wipe and place in a sealed plastic bag for at least one minute.
- Remove the strap from the bag, dispose of the wipe and allow the strap to dry in a well-ventilated area.

The strap can then be returned to stock for re-use.

User Manual-Smart Tag Location	Version:	1.6	
	Date:	07-04-14	
	Page:	11 of 12	

7.3. OBC

7.3.1. Collection

When collecting an On Body Charger from a subject protective gloves should be worn.

- Note any obvious sign of damage.
- Return the OBC and power leads to the vehicle for inspection and cleaning.

7.3.2. Inspection

The OBC should be inspected for signs of damage, units with damage should be dealt with in accordance with local protocols. Damage includes any significant surface marking which may be indicative of the unit being exposed to high impacts or tampering. Special care should be taken to inspect the following areas;

- Any seams between plastics, check for loose fits or evidence of attack by screwdriver or similar.
- The clipping features that lock the unit closed over the Smart Tag. Any damage to these could affect the unit's future performance.
- The charging cable and jack connectors. Any damage to this could mean the unit is unable to be recharged.
- The charging pins, any damage to these could mean the unit is not effective at charging a Smart Tag.

7.3.3. Cleaning

If there is any heavy soiling or biological matter on the unit that is unlikely to be easily removed by a sanitising wipe, then the unit should be cleaned thoroughly in line with local protocol. It should be noted that the OBC is only a splash proof product and therefore it is important not to fully immerse the unit in any liquid.

To sanitise an OBC in the field the following process should be followed;

- Wear gloves.
- Rub the unit vigorously with an approved sanitising wipe, ensuring all surfaces receive a good covering of alcohol.
- Allow to dry in a well-ventilated area.

The unit can then be returned to stock for re-use.

User Manual-Smart Tag Location	Version:	1.6	
	Date:	07-04-14	
	Page:	12 of 12	

8. FCC warning statement

- This device complies with Part 15 of the FCC Rules. Operation is subject to the following two conditions:
 - (1) This device may not cause harmful interference, and
 - (2) This device must accept any interference received, including interference that may cause undesired operation.
- This equipment complies with FCC radiation exposure limits set forth for an uncontrolled environment. End users must follow the specific operating instructions for satisfying RF exposure compliance. This transmitter must not be co-located or operating in conjunction with any other antenna or transmitter.
- Changes or modifications not expressly approved by the party responsible for compliance could void the user's authority to operate the equipment.
- This equipment has been tested for compliance with SAR limits for body worn configurations, the highest reported SAR values are 0.031 W/kg for PCS1900, 0.015 W/kg for GSM850 bands, 1.261 W/kg for WCDMA 2 and 0.634 W/kg for WCDMA 5

9. IC Warning Statement

Under Industry Canada regulations, this radio transmitter may only operate using an antenna of a type and maximum (or lesser) gain approved for the transmitter by Industry Canada.

To reduce potential radio interference to other users, the antenna type and its gain should be so chosen that the equivalent isotropically radiated power (e.i.r.p.) is not more than that necessary for successful communication.

This device complies with Industry Canada licence-exempt RSS standard(s). Operation is subject to the following two conditions: (1) this device may not cause interference, and (2) this device must accept any interference, including interference that may cause undesired operation of the device.