

FCC Part 15C

Measurement And Test Report For

Shenzhen Smart-eye Digital Electronics Co.,Ltd
#6 Northern Zone, Shangxue S&T City, Bantian,Longgang District,Shenzhen,China

FCC ID: ZCBHYIPC-629

Mar. 24, 2014

This Report Concerns: <input checked="" type="checkbox"/> Original Report	Equipment Type: IP CAMERA
Report Number:	MTI20140314001 RF
Test Engineer:	Bill Chen <i>Bill Chen</i>
Reviewed By:	Jason Zheng <i>Jason Zheng</i>
Approved & Authorized By:	Hebe Lee <i>Hebe Lee</i>
Test Date:	Mar. 13, 2014- Mar. 24, 2014
Prepared By:	Shenzhen Microtest Technology Co.,Ltd 6F, Zhongbao Building, Gushu, Bao'an District, Shenzhen, P.R.China Tel: +86-755-8885 0135 Fax: +86-755-8885 0136

Note: This test report is limited to the above client company and the product model only. It may not be duplicated without prior written consent of Shenzhen Microtest Technology Co.,Ltd.

TEST RESULT CERTIFICATION

Applicant's name		Shenzhen Smart-eye Digital Electronics Co.,Ltd
Address		#6 Northern Zone, Shangxue S&T City, Bantian, Longgang District,Shenzhen,China
Manufacture's Name		Shenzhen Smart-eye Digital Electronics Co.,Ltd
Address		#6 Northern Zone, Shangxue S&T City, Bantian, Longgang District,Shenzhen,China
Product description		
Product name		IP CAMERA
Model and/or type reference :		629W
Serial Model		559MD01W, 559MW,8559MW,6629W
Standards		FCC Part15.247
Test procedure		ANSI C63.4-2003

Table of Contents

	Page
1 . SUMMARY OF TEST RESULTS	5
1.1 TEST FACILITY	6
1.2 MEASUREMENT UNCERTAINTY	6
2 . GENERAL INFORMATION	7
2.1 GENERAL DESCRIPTION OF EUT	7
2.2 DESCRIPTION OF TEST MODES	9
2.3 BLOCK DIGRAM SHOWING THE CONFIGURATION OF SYSTEM TESTED	10
2.4 DESCRIPTION OF SUPPORT UNITS(CONDUCTED MODE)	11
2.5 EQUIPMENTS LIST FOR ALL TEST ITEMS	12
3 . EMC EMISSION TEST	13
3.1 CONDUCTED EMISSION MEASUREMENT	13
3.1.1 POWER LINE CONDUCTED EMISSION LIMITS	13
3.1.2 TEST PROCEDURE	14
3.1.3 DEVIATION FROM TEST STANDARD	14
3.1.4 TEST SETUP	14
3.1.5 EUT OPERATING CONDITIONS	14
3.1.6 TEST RESULTS	15
3.2 RADIATED EMISSION MEASUREMENT	17
3.2.1 RADIATED EMISSION LIMITS	17
3.2.2 TEST PROCEDURE	18
3.2.3 DEVIATION FROM TEST STANDARD	18
3.2.4 TEST SETUP	19
3.2.5 EUT OPERATING CONDITIONS	20
3.2.6 TEST RESULTS (BETWEEN 9KHZ - 30 MHZ)	21
3.2.7 TEST RESULTS (BETWEEN 30MHZ - 1GHZ)	22
3.2.8 TEST RESULTS (ABOVE 1000 MHZ)	23
3.3 BAND EDGE EMISSION(RADIATED MEASUREMENT):	24
4 . POWER SPECTRAL DENSITY TEST	34
4.1 APPLIED PROCEDURES / LIMIT	34
4.1.1 TEST PROCEDURE	34
4.1.2 DEVIATION FROM STANDARD	34
4.1.3 TEST SETUP	34
4.1.4 EUT OPERATION CONDITIONS	34
4.1.5 TEST RESULTS	35
5 . BANDWIDTH TEST	41
5.1 APPLIED PROCEDURES / LIMIT	41
5.1.1 TEST PROCEDURE	41

Table of Contents

	Page
5.1.2 DEVIATION FROM STANDARD	41
5.1.3 TEST SETUP	41
5.1.4 EUT OPERATION CONDITIONS	41
5.1.5 TEST RESULTS	42
6 . PEAK OUTPUT POWER TEST	48
6.1 APPLIED PROCEDURES / LIMIT	48
6.1.1 TEST PROCEDURE	48
6.1.2 DEVIATION FROM STANDARD	48
6.1.3 TEST SETUP	48
6.1.4 EUT OPERATION CONDITIONS	48
6.1.5 TEST RESULTS	49
7 . 100 KHZ BANDWIDTH OF FREQUENCY BAND EDGE	50
7.1 DEVIATION FROM STANDARD	50
7.2 TEST SETUP	50
7.3 EUT OPERATION CONDITIONS	50
7.4 TEST RESULTS	51
8 . ANTENNA REQUIREMENT	55
8.1 STANDARD REQUIREMENT	55
8.2 EUT ANTENNA	55
9 . EUT TEST PHOTO	56

1. SUMMARY OF TEST RESULTS

Test procedures according to the technical standards:

FCC Part15 (15.247) , Subpart C			
Standard Section	Test Item	Judgment	Remark
15.207	Conducted Emission	PASS	
15.247 (a)(2)	6dB Bandwidth	PASS	
15.247 (b)	Peak Output Power	PASS	
15.247 (c)	Radiated Spurious Emission	PASS	
15.247 (d)	Power Spectral Density	PASS	
15.205	Band Edge Emission	PASS	
15.203	Antenna Requirement	PASS	

NOTE:

(1) "N/A" denotes test is not applicable in this Test Report

1.1 TEST FACILITY

NTEK Testing Technology Co., Ltd

Add. : 1/F, Building E, Fenda Science Park, Sanwei Community, Xixiang Street, Bao'an District, Shenzhen P.R. China.

FCC Registration No.:238937; IC Registration No.:9270A-1

1.2 MEASUREMENT UNCERTAINTY

The reported uncertainty of measurement $y \pm U$, where expanded uncertainty U is based on a standard uncertainty multiplied by a coverage factor of $k=2$, providing a level of confidence of approximately 95 %.

No.	Item	Uncertainty
1	Conducted Emission Test	$\pm 1.38\text{dB}$
2	RF power,conducted	$\pm 0.16\text{dB}$
3	Spurious emissions,conducted	$\pm 0.21\text{dB}$
4	All emissions,radiated(<1G)	$\pm 4.68\text{dB}$
5	All emissions,radiated(>1G)	$\pm 4.89\text{dB}$
6	Temperature	$\pm 0.5^{\circ}\text{C}$
7	Humidity	$\pm 2\%$

2. GENERAL INFORMATION

2.1 GENERAL DESCRIPTION OF EUT

Equipment	IP CAMERA	
Trade Name	N/A	
Model Name	629W	
Serial Model	559MD01W, 559MW,8559MW,6629W	
Model Difference	All the same, Only model name is different.	
Product Description	The EUT is a IP CAMERA	
	Operation Frequency:	802.11b/g/n(20):2412~2462 MHz
	Modulation Type:	CCK/OFDM/DBPSK/DAPSK
	Bit Rate of Transmitter	802.11b:11/5.5/2/1 Mbps 802.11g:54/48/36/24/18/12/9/6 Mbps 802.11n(20MHz): 78/52/6.5 Mbps
	Number Of Channel	802.11b/g/n:11CH
	Antenna Designation:	Please see Note 3.
	Output Power(Conducted):	802.11b: 17.44 dBm (Max.) 802.11g: 14.42 dBm (Max.) 802.11n: 14.24 dBm (Max.)
	Antenna Gain (dBi)	1.0dbi
	Based on the application, features, or specification exhibited in User's Manual, the EUT is considered as an ITE/Computing Device. More details of EUT technical specification, please refer to the User's Manual.	
Channel List	Please refer to the Note 2.	
Ratings	DC 3.7V	
Adapter	Model:SW-050150 AC Power Input: 100-240V~, 50/60Hz, 0.3A Output: 5.0V---, 1500mA	
Battery	N/A	
Connecting I/O Port(s)	Please refer to the User's Manual	

Note:

1. For a more detailed features description, please refer to the manufacturer's specifications or the User's Manual.

2.

Channel List for 802.11b/g/n							
Channel	Frequency (MHz)	Channel	Frequency (MHz)	Channel	Frequency (MHz)	Channel	Frequency (MHz)
01	2412	04	2427	07	2442	10	2457
02	2417	05	2432	08	2447	11	2462
03	2422	06	2437	09	2452		

3.

Table for Filed Antenna

Ant	Brand	Model Name	Antenna Type	Connector	Gain (dBi)	NOTE
A	N/A	N/A	FPCB Antenna	N/A	1.0	Wifi Antenna

2.2 DESCRIPTION OF TEST MODES

To investigate the maximum EMI emission characteristics generates from EUT, the test system was pre-scanning tested base on the consideration of following EUT operation mode or test configuration mode which possible have effect on EMI emission level. Each of these EUT operation mode(s) or test configuration mode(s) mentioned above was evaluated respectively.

Pretest Mode	Description
Mode 1	802.11b CH1/ CH6/ CH11
Mode 2	802.11g CH1/ CH6/ CH11
Mode 3	802.11n(20) CH1/ CH6/ CH11
Mode 4	Link Mode

For Conducted Emission	
Final Test Mode	Description
Mode 4	Link Mode

For Radiated Emission	
Final Test Mode	Description
Mode 1	802.11b CH1/ CH6/ CH11
Mode 2	802.11g CH1/ CH6/ CH11
Mode 3	802.11n CH1/ CH6/ CH11
Mode 4	Link Mode

Note:

- (1) The measurements are performed at the highest, middle, lowest available channels.
- (2) The measurements are performed at all Bit Rate of Transmitter, the worst data was reported

2.3 BLOCK DIGRAM SHOWING THE CONFIGURATION OF SYSTEM TESTED

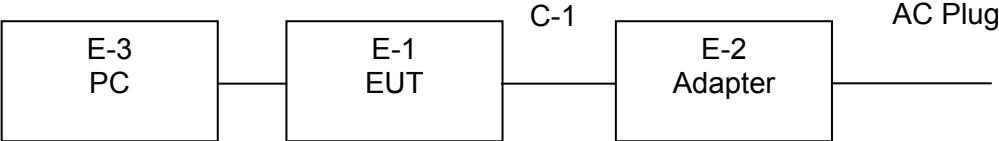

NOTE: PC can control the EUT transmit at a frequency point.

2.4 DESCRIPTION OF SUPPORT UNITS(CONDUCTED MODE)

The EUT has been tested as an independent unit together with other necessary accessories or support units. The following support units or accessories were used to form a representative test configuration during the tests.

Item	Equipment	Brand	Model/Type No.	Series No.	Note
E-1	IP CAMERA	N/A	629W	N/A	EUT
E-2	Adapter	N/A	SW-050150	N/A	
E-3	PC	DELL	PP10L	N/A	Notebook

Item	Shielded Type	Ferrite Core	Length	Note
C-1	NO	NO	1.0m	
C-2	NO	NO	1.0m	

Note:

- (1) The support equipment was authorized by Declaration of Confirmation.
- (2) For detachable type I/O cable should be specified the length in cm in 『Length』 column.

2.5 EQUIPMENTS LIST FOR ALL TEST ITEMS

Radiation Test equipment

Item	Kind of Equipment	Manufacturer	Type No.	Serial No.	Last calibration	Calibrated until	Calibration period
1	Spectrum Analyzer	Agilent	E4407B	MY45108040	2013.07.06	2014.07.05	1 year
2	Test Receiver	R&S	ESPI	101318	2013.06.07	2014.06.06	1 year
3	Bilog Antenna	TESEQ	CBL6111D	31216	2013.07.06	2014.07.05	1 year
4	50Ω Coaxial Switch	Anritsu	MP59B	6200264416	2013.06.07	2014.06.06	1 year
5	Spectrum Analyzer	ADVANTEST	R3132	150900201	2013.06.07	2014.06.06	1 year
6	Horn Antenna	EM	EM-AH-10180	2011071402	2013.07.06	2014.07.05	1 year
7	Horn Ant	Schwarzbeck	BBHA 9170	9170-181	2013.07.06	2014.07.05	1 year
8	Amplifier	EM	EM-30180	060538	2013.12.22	2014.12.21	1 year
9	Loop Antenna	ARA	PLA-1030/B	1029	2013.06.08	2014.06.07	1 year
10	Power Meter	R&S	NRVS	100696	2013.07.06	2014.07.05	1 year
11	Power Sensor	R&S	URV5-Z4	0395.1619.05	2013.07.06	2014.07.05	1 year

Conduction Test equipment

Item	Kind of Equipment	Manufacturer	Type No.	Serial No.	Last calibration	Calibrated until	Calibration period
1	Test Receiver	R&S	ESCI	101160	2013.06.06	2014.06.05	1 year
2	LISN	R&S	ENV216	101313	2013.08.24	2014.08.23	1 year
3	LISN	EMCO	3816/2	00042990	2013.08.24	2014.08.23	1 year
4	50Ω Coaxial Switch	Anritsu	MP59B	6200264417	2013.06.07	2014.06.06	1 year
5	Passive Voltage Probe	R&S	ESH2-Z3	100196	2013.06.07	2014.06.06	1 year
6	Absorbing clamp	R&S	MOS-21	100423	2013.06.08	2014.06.07	1 year

3. EMC EMISSION TEST

3.1 CONDUCTED EMISSION MEASUREMENT

3.1.1 POWER LINE CONDUCTED EMISSION Limits (Frequency Range 150KHz-30MHz)

FREQUENCY (MHz)	Class A (dBuV)		Class B (dBuV)		Standard
	Quasi-peak	Average	Quasi-peak	Average	
0.15 -0.5	79.00	66.00	66 - 56 *	56 - 46 *	CISPR
0.50 -5.0	73.00	60.00	56.00	46.00	CISPR
5.0 -30.0	73.00	60.00	60.00	50.00	CISPR

0.15 -0.5	79.00	66.00	66 - 56 *	56 - 46 *	FCC
0.50 -5.0	73.00	60.00	56.00	46.00	FCC
5.0 -30.0	73.00	60.00	60.00	50.00	FCC

Note:

- (1) The tighter limit applies at the band edges.
- (2) The limit of " * " marked band means the limitation decreases linearly with the logarithm of the frequency in the range.

The following table is the setting of the receiver

Receiver Parameters	Setting
Attenuation	10 dB
Start Frequency	0.15 MHz
Stop Frequency	30 MHz
IF Bandwidth	9 kHz

3.1.2 TEST PROCEDURE

- a. The EUT was placed 0.8 meters from the horizontal ground plane with EUT being connected to the power mains through a line impedance stabilization network (LISN). All other support equipments powered from additional LISN(s). The LISN provide 50 Ohm/ 50uH of coupling impedance for the measuring instrument.
- b. Interconnecting cables that hang closer than 40 cm to the ground plane shall be folded back and forth in the center forming a bundle 30 to 40 cm long.
- c. I/O cables that are not connected to a peripheral shall be bundled in the center. The end of the cable may be terminated, if required, using the correct terminating impedance. The overall length shall not exceed 1 m.
- d. LISN at least 80 cm from nearest part of EUT chassis.
- e. For the actual test configuration, please refer to the related Item –EUT Test Photos.

3.1.3 DEVIATION FROM TEST STANDARD

No deviation

3.1.4 TEST SETUP

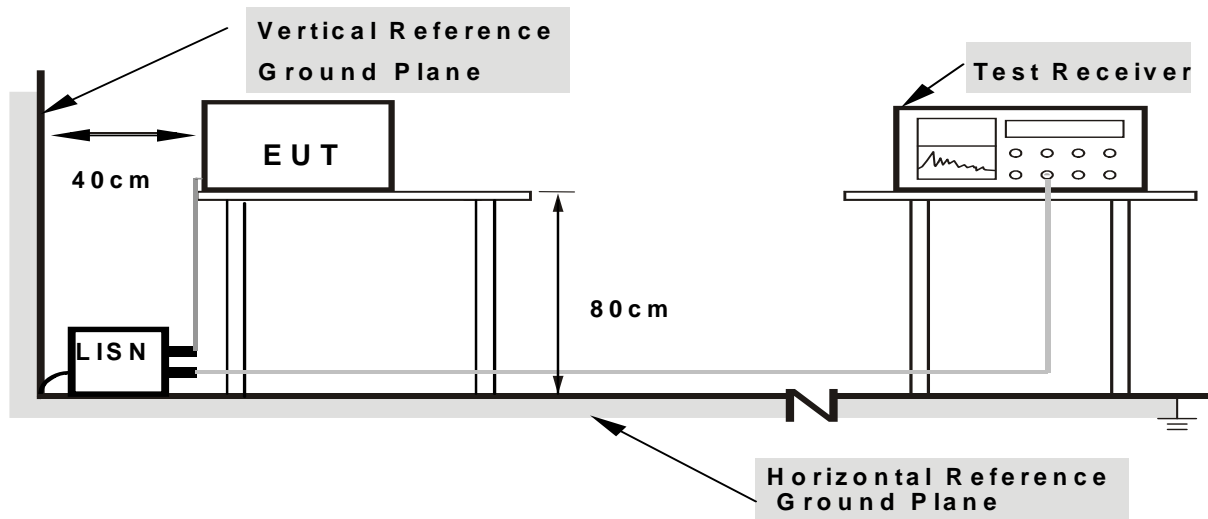

- Note:** 1.Support units were connected to second LISN.
2.Both of LISNs (AMN) are 80 cm from EUT and at least 80 from other units and other metal planes

3.1.5 EUT OPERATING CONDITIONS

The EUT was configured for testing in a typical fashion (as a customer would normally use it). The EUT has been programmed to continuously transmit during test. This operating condition was tested and used to collect the included data.

3.1.6 TEST RESULTS

EUT :	IP CAMERA	Model Name. :	629W
Temperature :	26 °C	Relative Humidity :	54%
Pressure :	1010hPa	Phase :	L
Test Voltage :	DC 5.0V from adapter AC 120V/60Hz	Test Mode :	Mode 1

Frequency (MHz)	Meter Reading (dBμV)	Factor (dB)	Emission Level (dBμV)	Limits (dBμV)	Margin (dB)	Detector Type
0.1900	27.85	10.83	38.68	64.03	-25.35	peak
0.7820	25.10	10.52	35.62	56.00	-20.38	peak
12.5300	31.12	10.87	41.99	60.00	-18.01	peak
0.1580	12.98	11.36	24.34	55.56	-31.22	AVG
0.3820	13.44	10.75	24.19	48.23	-24.04	AVG
12.3260	13.78	10.88	24.66	50.00	-25.34	AVG

Remark:

1. All readings are Peak and Average values.
2. Factor = Insertion Loss + Cable Loss.
3. Factor added by measurement software automatically.

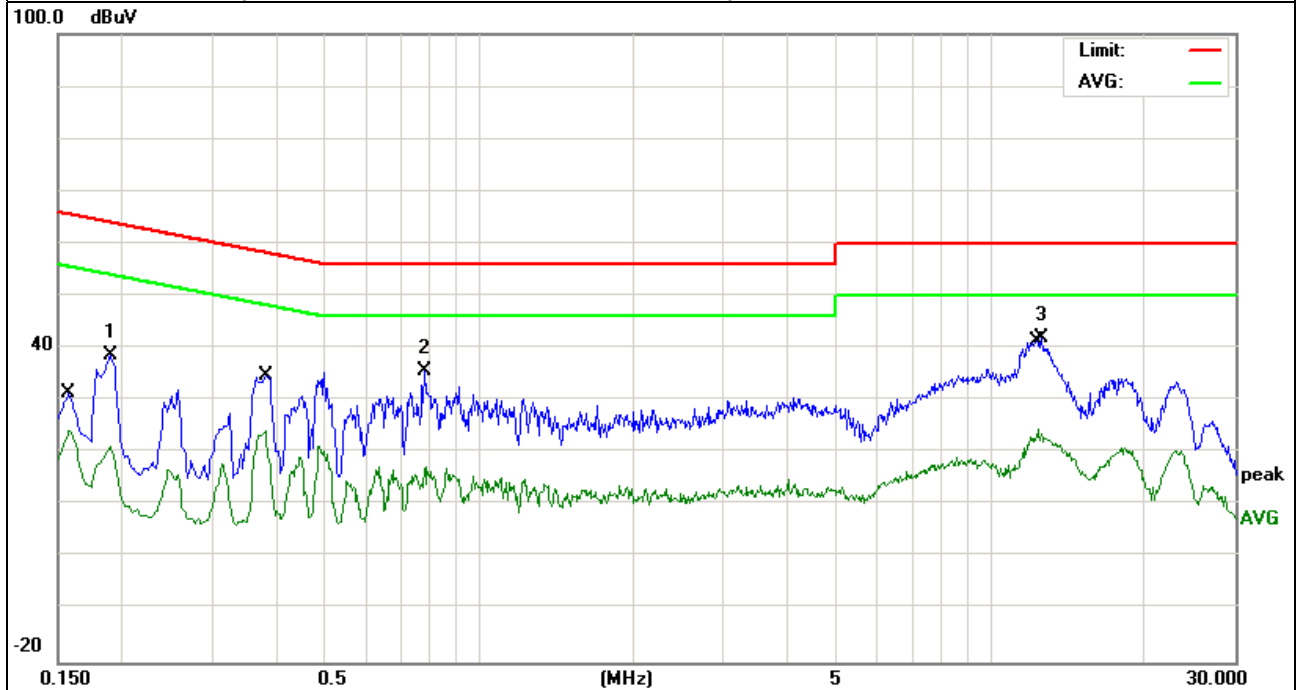

EUT :	IP CAMERA	Model Name. :	629W
Temperature :	26 °C	Relative Humidity :	54%
Pressure :	1010hPa	Phase :	N
Test Voltage :	DC 5.0V from adapter AC 120V/60Hz	Test Mode :	Mode 1

Frequency (MHz)	Meter Reading (dBμV)	Factor (dB)	Emission Level (dBμV)	Limits (dBμV)	Margin (dB)	Detector Type
0.3860	30.89	10.74	41.63	58.15	-16.52	peak
0.4860	28.23	10.60	38.83	56.24	-17.41	peak
12.1940	33.31	10.88	44.19	60.00	-15.81	peak
0.3780	20.58	10.77	31.35	48.32	-16.97	AVG
0.4900	16.11	10.60	26.71	46.17	-19.46	AVG
12.5060	16.66	10.87	27.53	50.00	-22.47	AVG

Remark:

1. All readings are Peak and Average values.
2. Factor = Insertion Loss + Cable Loss.
3. Factor added by measurement software automatically.

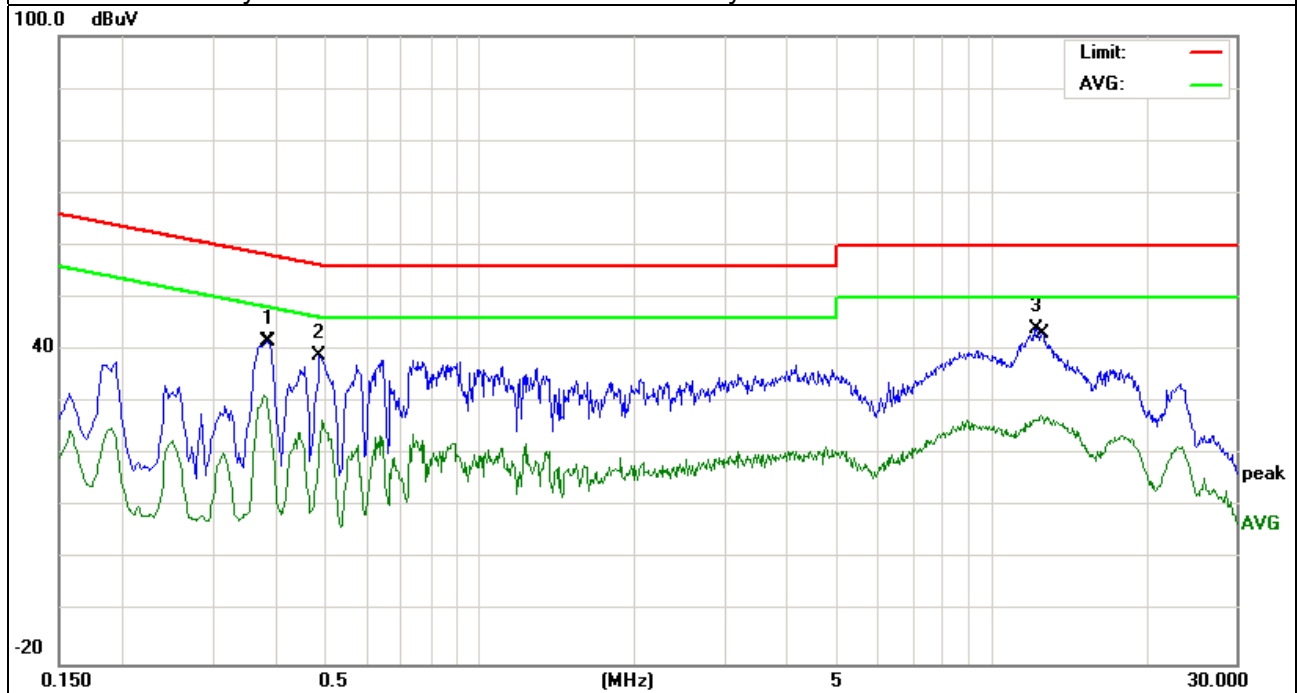

3.2 RADIATED EMISSION MEASUREMENT

3.2.1 RADIATED EMISSION LIMITS (Frequency Range 9kHz-1000MHz)

20dBc in any 100 kHz bandwidth outside the operating frequency band. In case the emission fall within the restricted band specified on 15.205(a), then the 15.209(a) limit in the table below has to be followed.

Frequencies (MHz)	Field Strength (micovolts/meter)	Measurement Distance (meters)
0.009~0.490	2400/F(KHz)	300
0.490~1.705	24000/F(KHz)	30
1.705~30.0	30	30
30~88	100	3
88~216	150	3
216~960	200	3
Above 960	500	3

LIMITS OF RADIATED EMISSION MEASUREMENT (Above 1000MHz)

FREQUENCY (MHz)	Class A (dBuV/m) (at 3M)		Class B (dBuV/m) (at 3M)	
	PEAK	AVERAGE	PEAK	AVERAGE
Above 1000	80	60	74	54

Notes:

- (1) The limit for radiated test was performed according to FCC PART 15C.
- (2) The tighter limit applies at the band edges.
- (3) Emission level (dBuV/m)=20log Emission level (uV/m).

Spectrum Parameter	Setting
Attenuation	Auto
Start Frequency	1000 MHz
Stop Frequency	10th carrier harmonic
RB / VB (emission in restricted band)	1 MHz / 1 MHz for Peak, 1 MHz / 10Hz for Average

Receiver Parameter	Setting
Attenuation	Auto
Start ~ Stop Frequency	9kHz~150kHz / RB 200Hz for QP
Start ~ Stop Frequency	150kHz~30MHz / RB 9kHz for QP
Start ~ Stop Frequency	30MHz~1000MHz / RB 120kHz for QP

3.2.2 TEST PROCEDURE

- a. The measuring distance of at 3 m shall be used for measurements at frequency up to 1GHz. For frequencies above 1GHz, any suitable measuring distance may be used.
- b. The EUT was placed on the top of a rotating table 0.8 meters above the ground at a 3 meter open area test site. The table was rotated 360 degrees to determine the position of the highest radiation.
- c. The height of the equipment or of the substitution antenna shall be 0.8 m; the height of the test antenna shall vary between 1 m to 4 m. Both horizontal and vertical polarizations of the antenna are set to make the measurement.
- d. The initial step in collecting conducted emission data is a spectrum analyzer peak detector mode pre-scanning the measurement frequency range. Significant peaks are then marked and then Quasi Peak detector mode re-measured.
- e. If the Peak Mode measured value compliance with and lower than Quasi Peak Mode Limit, the EUT shall be deemed to meet QP Limits and then no additional QP Mode measurement performed.
- f. For the actual test configuration, please refer to the related Item –EUT Test Photos.

Note:

Both horizontal and vertical antenna polarities were tested and performed pretest to three orthogonal axis. The worst case emissions were reported

3.2.3 DEVIATION FROM TEST STANDARD

No deviation

3.2.4 TEST SETUP

(A) Radiated Emission Test-Up Frequency Below 30MHz

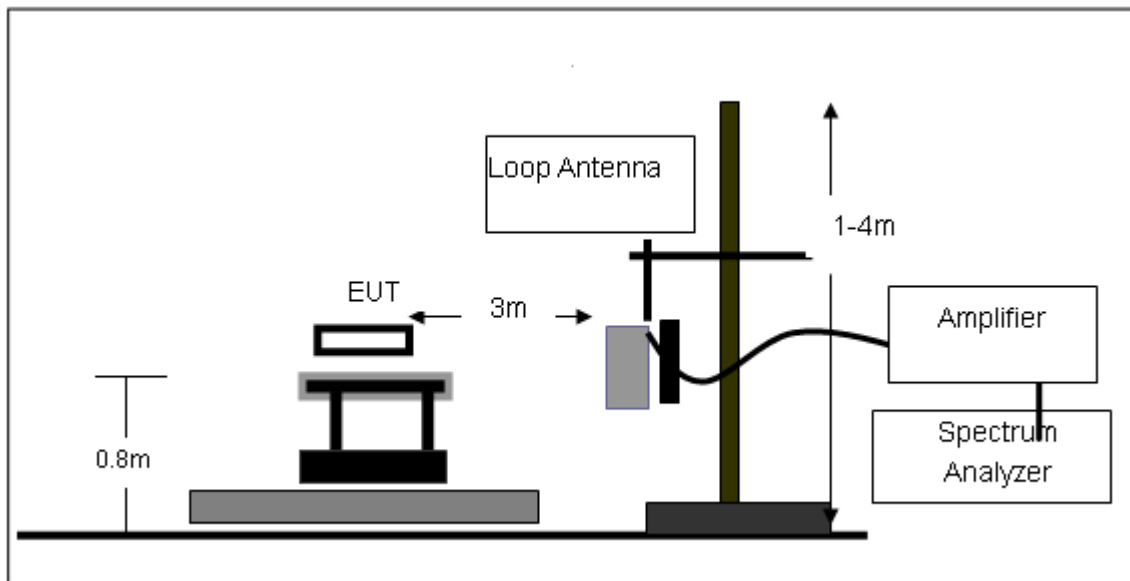

(B) Radiated Emission Test-Up Frequency 30MHz~1GHz

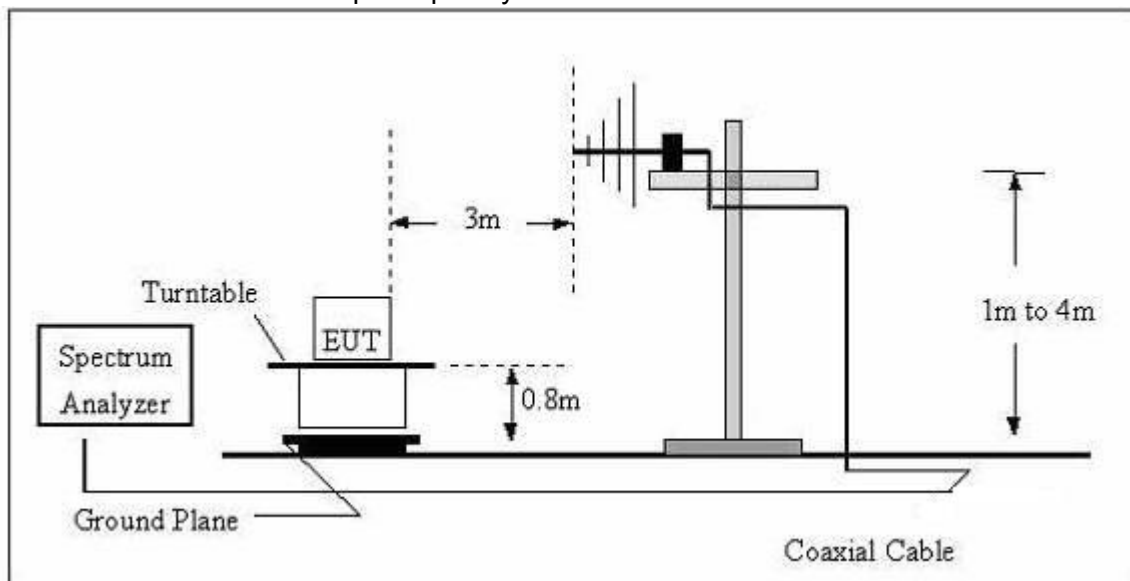

(C) Radiated Emission Test-Up Frequency Above 1GHz

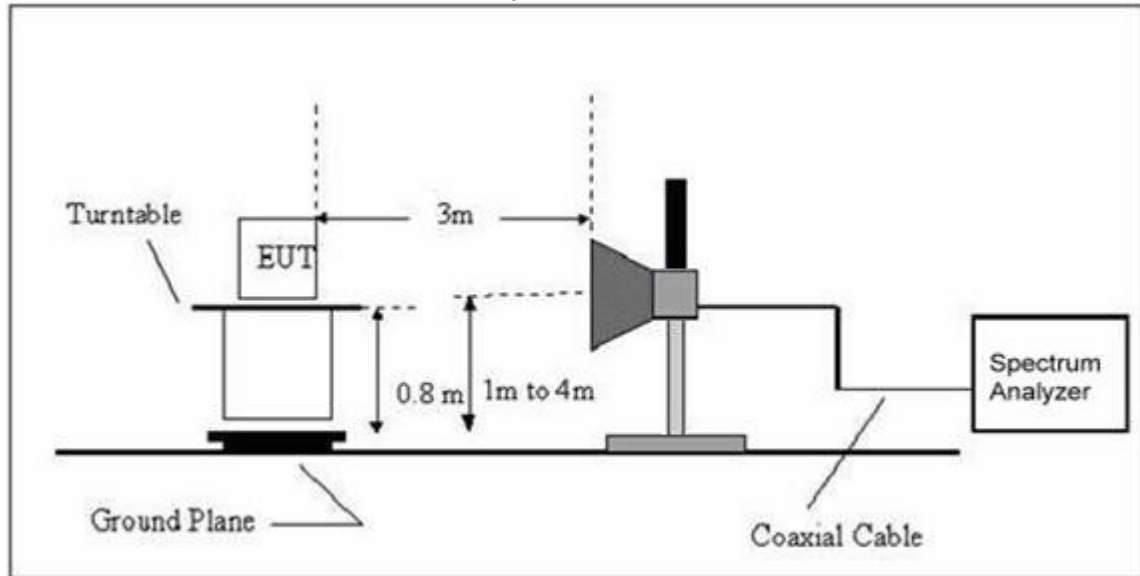

3.2.5 EUT OPERATING CONDITIONS

The EUT tested system was configured as the statements of 2.4 Unless otherwise a special operating condition is specified in the follows during the testing.

3.2.6 TEST RESULTS (BETWEEN 9KHZ – 30 MHZ)

EUT:	IP CAMERA	Model Name. :	629W
Temperature:	20 °C	Relative Humidity:	48%
Pressure:	1010 hPa	Test Voltage :	DC 5.0V from adapter AC 120V/60Hz
Test Mode :	TX	Polarization :	--

Freq.	Reading	Limit	Margin	State
(MHz)	(dBuV/m)	(dBuV/m)	(dB)	P/F
--	--	--	--	PASS
--	--	--	--	PASS

NOTE:

The amplitude of spurious emissions which are attenuated by more than 20dB below the permissible value has no need to be reported.

Distance extrapolation factor = $40 \log (\text{specific distance}/\text{test distance})(\text{dB})$;

Limit line = specific limits(dBuv) + distance extrapolation factor.

3.2.7 TEST RESULTS (BETWEEN 30MHZ – 1GHZ)

EUT :	IP CAMERA	Model Name :	629W
Temperature :	20 °C	Relative Humidity :	48%
Pressure:	1010 hPa	Test Voltage :	DC 5.0V from adapter
Test Mode :	TX		

Polar (H/V)	Frequency	Meter Reading	Factor	Emission Level	Limits	Margin	Detector Type
	(MHz)	(dBuV)	(dB)	(dBuV/m)	(dBuV/m)	(dB)	
V	88.0327	23.92	9.08	33	43.5	-10.5	QP
V	143.3258	24.47	11.93	36.4	43.5	-7.1	QP
V	311.0867	23.89	14.61	38.5	46	-7.5	QP
H	87.4175	22.57	9.03	31.6	40	-8.4	QP
H	143.8292	16.41	11.93	28.34	43.5	-15.16	QP
H	301.4223	21.02	14.58	35.6	46	-10.4	QP
H	896.9963	15.01	25.59	40.6	46	-5.4	QP

Remark:

Absolute Level= ReadingLevel+ Factor, Margin= Limit- Absolute Level

Factor added by measurement software automatically.

3.2.8 TEST RESULTS (ABOVE 1000 MHZ)

802.11b

Normal Voltage

Polar (H/V)	Frequency	Meter Reading	Factor	Emission Level	Limits	Margin	Detector Type
	(MHz)	(dBuV)	(dB)	(dBuV/m)	(dBuV/m)	(dB)	
Low Channel (2412 MHz)							
Vertical	4824.127	46.08	10.44	56.52	74	-17.48	peak
Vertical	4824.127	32.81	10.44	43.25	54	-10.75	AVG
Vertical	7236.338	39.1	12.39	51.49	74	-22.51	peak
Vertical	7236.338	28.87	12.39	41.26	54	-12.74	AVG
Horizontal	4824.289	48.31	10.44	58.75	74	-15.25	peak
Horizontal	4824.289	36.48	10.44	46.92	54	-7.08	AVG
Horizontal	7236.455	40.87	12.39	53.26	74	-20.74	peak
Horizontal	7236.455	31.4	12.39	43.79	54	-10.21	AVG
Middle Channel (2437 MHz)							
Vertical	4874.039	48.97	10.4	59.37	74	-14.63	peak
Vertical	4874.039	37.92	10.4	48.32	54	-5.68	AVG
Vertical	7311.591	42.68	12.75	55.43	74	-18.57	peak
Vertical	7311.591	31	12.75	43.75	54	-10.25	AVG
Horizontal	4874.408	48.88	10.4	59.28	74	-14.72	peak
Horizontal	4874.488	35.22	10.4	45.62	54	-8.38	AVG
Horizontal	7311.351	42.66	12.75	55.41	74	-18.59	peak
Horizontal	7311.351	31.61	12.75	44.36	54	-9.64	AVG
High Channel (2462 MHz)							
Vertical	4924.075	49.49	10.39	59.88	74	-14.12	peak
Vertical	4924.075	34.96	10.44	45.4	54	-8.6	AVG
Vertical	7386.152	40.56	12.68	53.24	74	-20.76	peak
Vertical	7386.152	29.85	12.68	42.53	54	-11.47	AVG
Horizontal	4924.263	48.32	10.39	58.71	74	-15.29	peak
Horizontal	4924.263	34.97	10.39	45.36	54	-8.64	AVG
Horizontal	7386.154	42.9	12.68	55.58	74	-18.42	peak
Horizontal	7386.154	29.95	12.68	42.63	54	-11.37	AVG

Note: "802.11b" mode is the worst mode.

Factor = Antenna Factor + Cable Loss – Pre-amplifier.

Factor added by measurement software automatically.

3.3 BAND EDGE EMISSION(RADIATED MEASUREMENT):

Frequency (MHz)	Meter Reading (dB μ V)	Factor (dB)	Emission Level (dB μ V/m)	Limits (dB μ V/m)	Margin (dB)	Detector Type	Comment
802.11b							
2390	58.36	-13.06	45.30	74	-28.70	peak	Vertical
2390	59.20	-13.06	46.14	74	-27.86	peak	Horizontal
2483.5	59.20	-12.78	46.42	74	-27.58	peak	Vertical
2483.5	52.74	-12.78	39.96	74	-34.04	peak	Horizontal
802.11g							
2390	58.41	-13.06	45.35	74	-28.65	peak	Vertical
2390	55.29	-13.06	42.23	74	-31.77	peak	Horizontal
2483.5	60.51	-12.78	47.73	74	-26.27	peak	Vertical
2483.5	61.19	-12.78	48.41	74	-25.59	peak	Horizontal
802.11n							
2390	61.94	-13.06	48.88	74	-25.12	peak	Vertical
2390	61.97	-13.06	48.91	74	-25.09	peak	Horizontal
2483.5	58.21	-12.78	45.46	74	-28.54	peak	Vertical
2483.5	55.51	-12.78	42.73	74	-31.27	peak	Horizontal

Note: Factor = Antenna Factor + Cable Loss – Pre-amplifier.
Factor added by measurement software automatically.
Emission Level is less(PK) than AV Limits, No need AV lever

Conducted Spurious Emissions at Antenna Port:
802.11b Low Channel

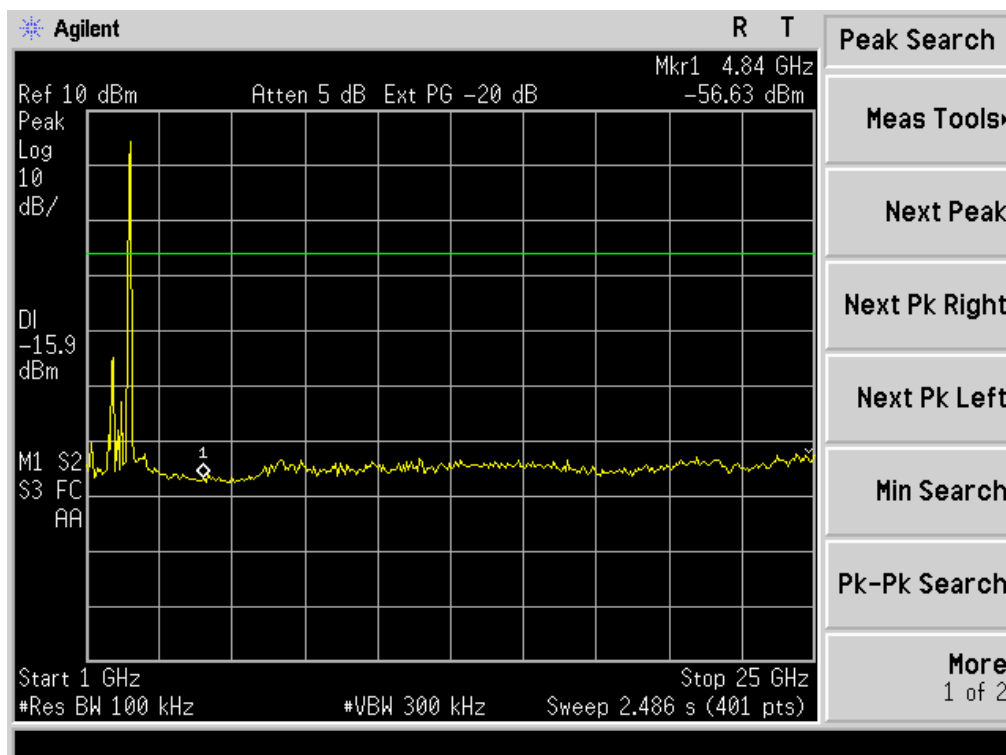
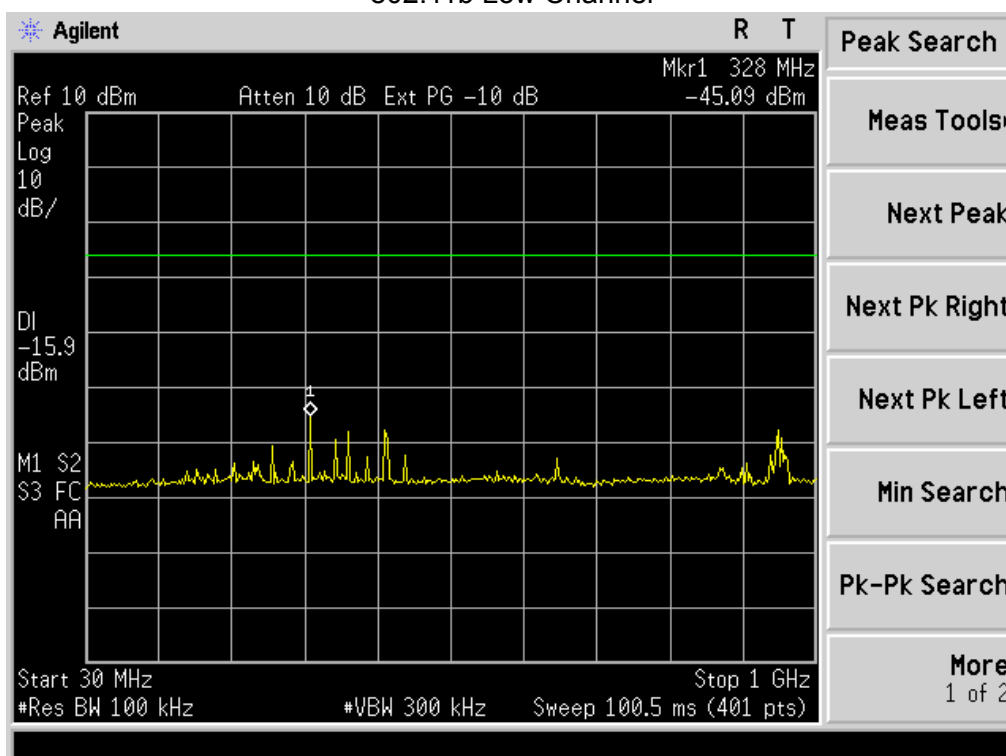

802.11b Middle Channel

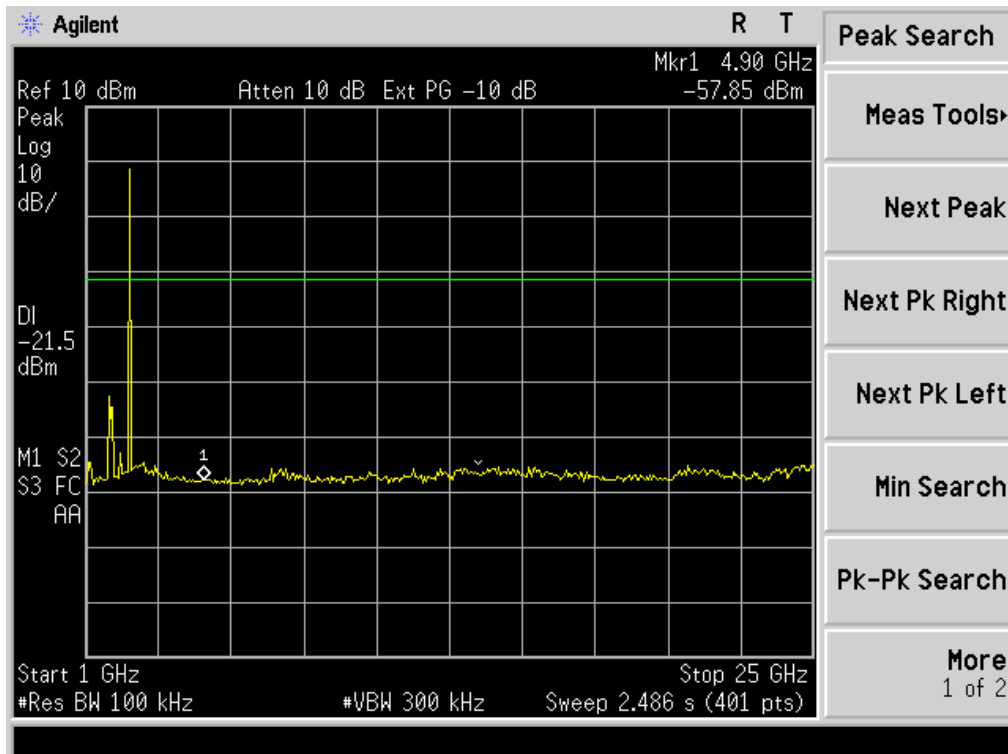
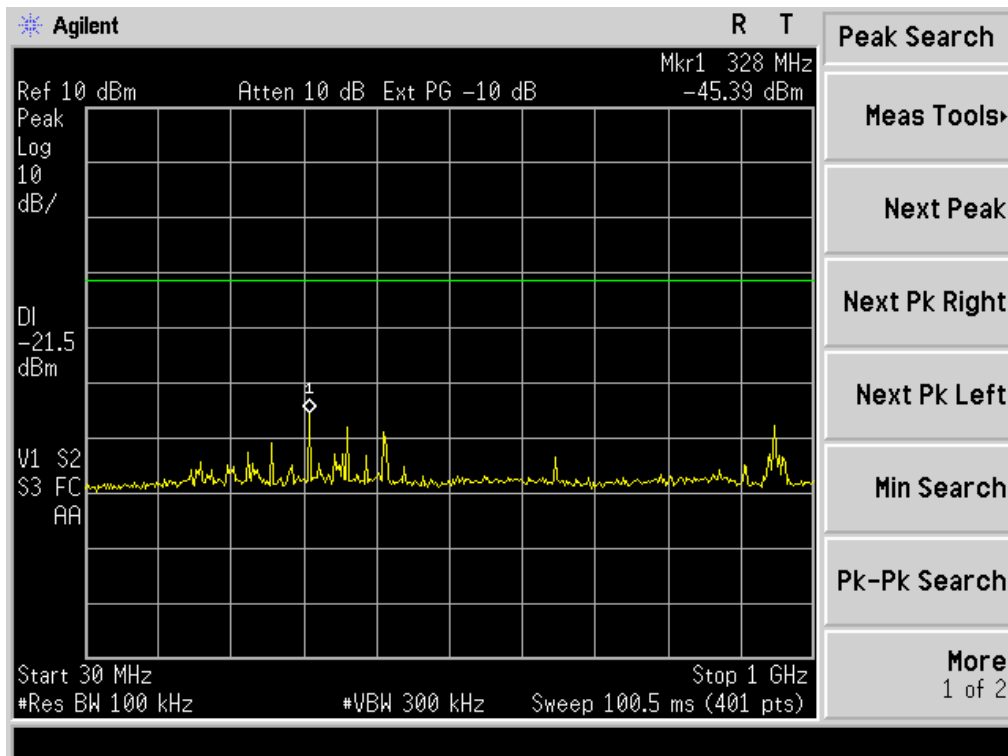

802.11b High Channel

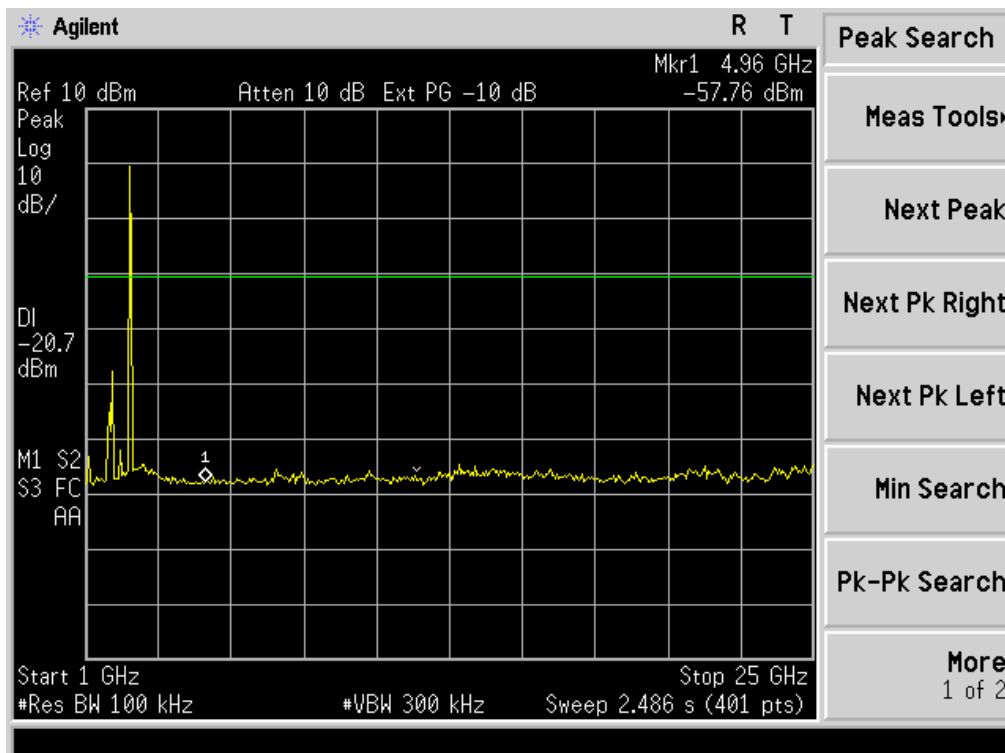
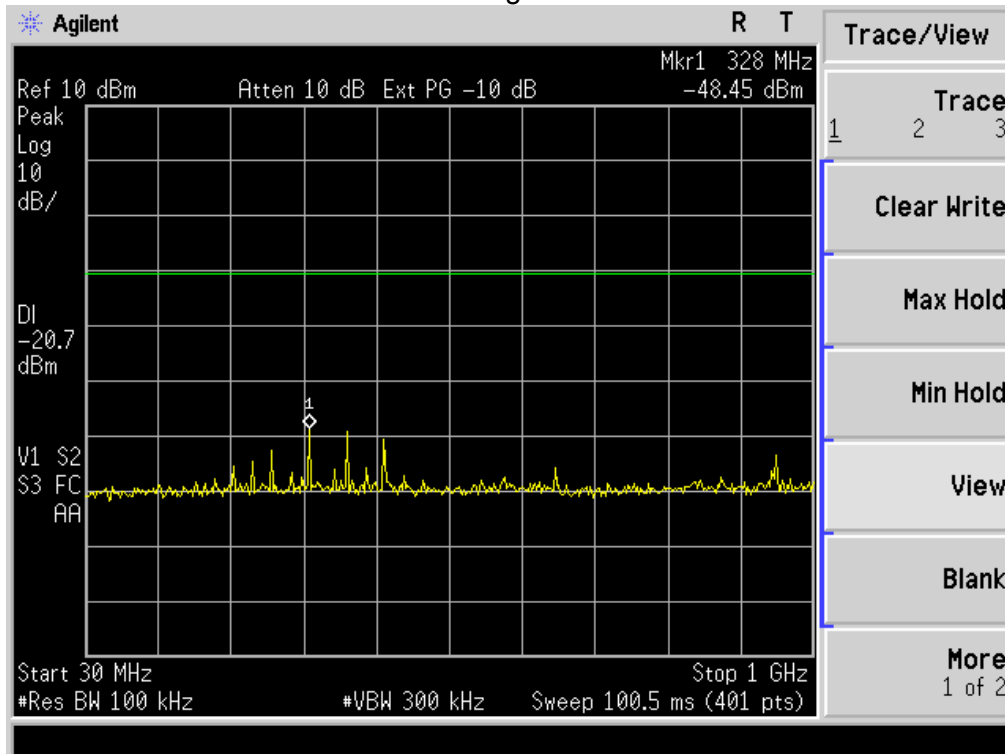

802.11g Low Channel

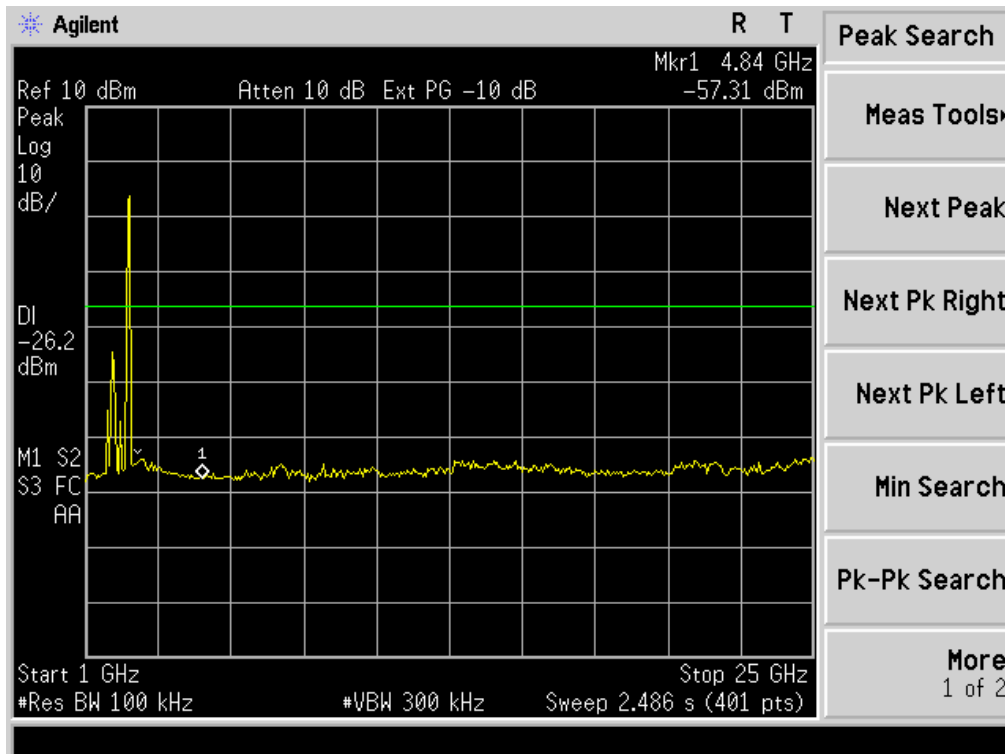
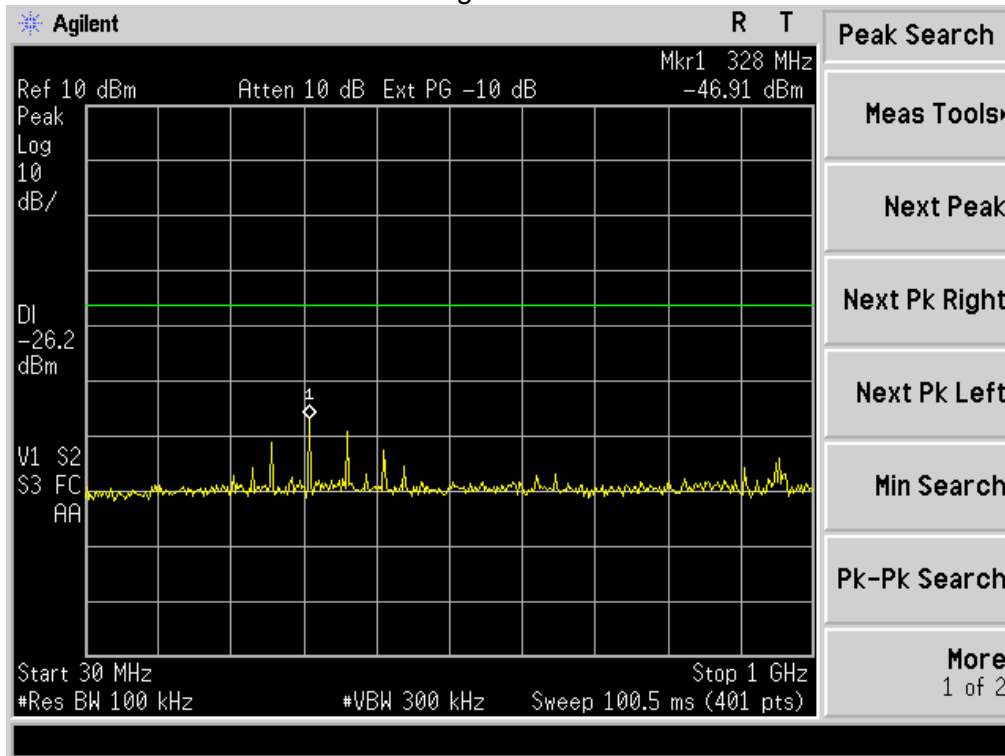

802.11g Middle Channel

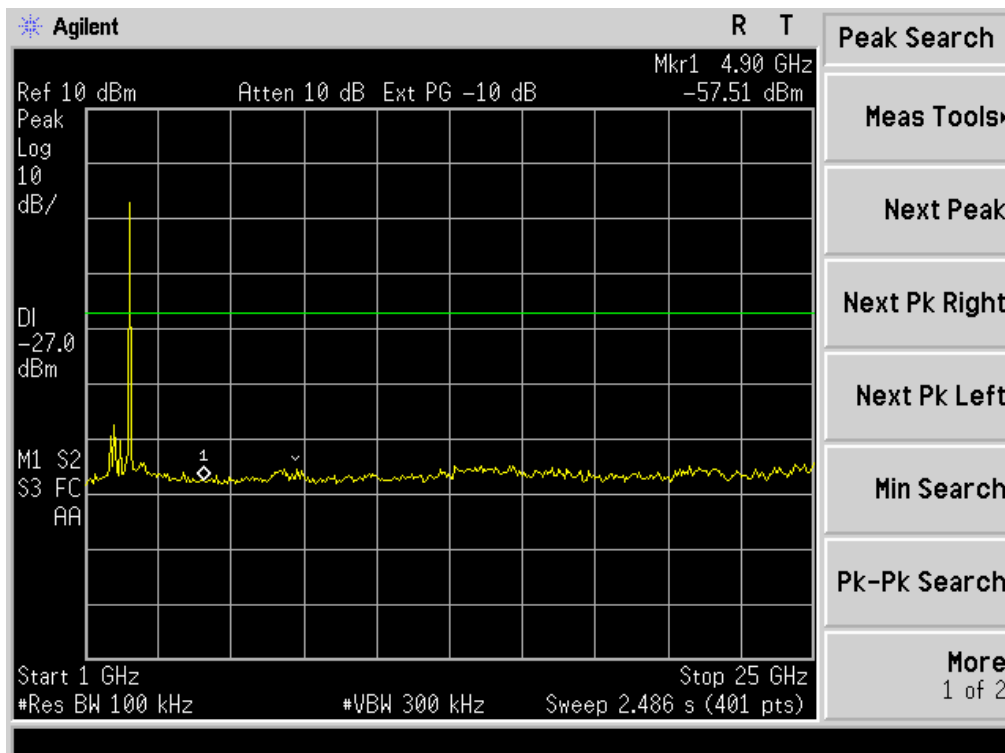
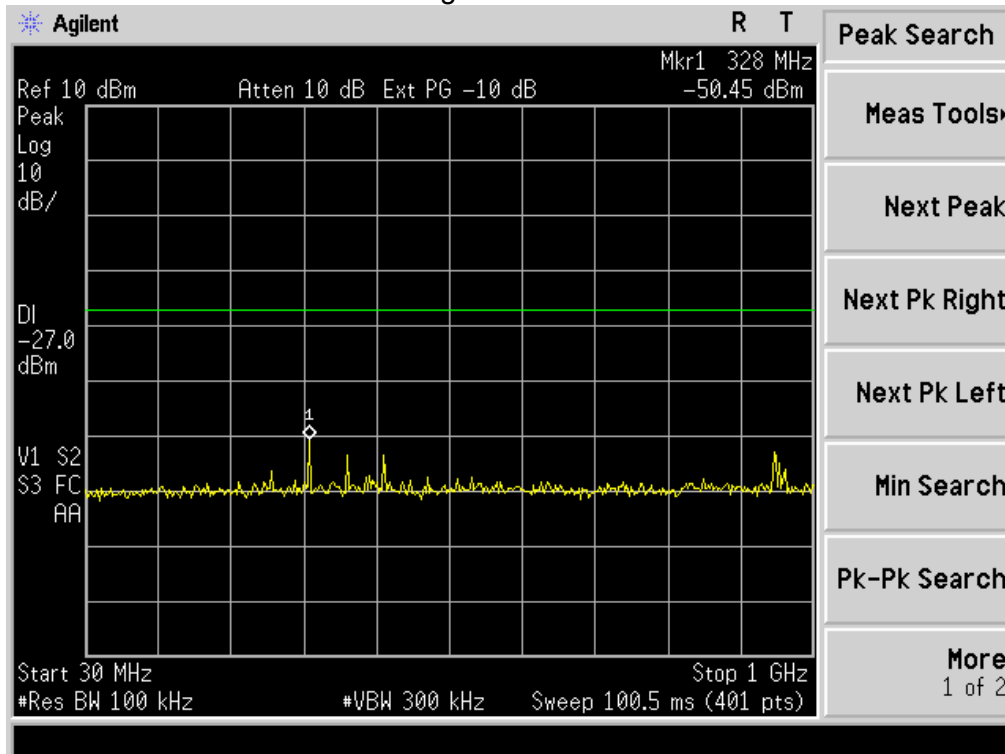

802.11g High Channel

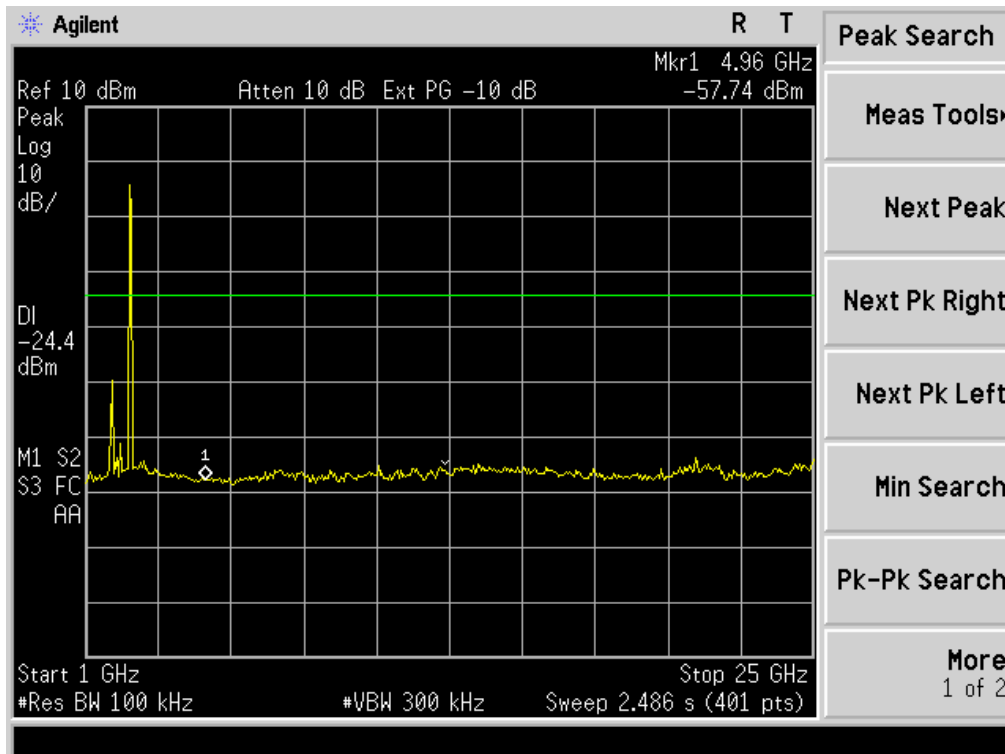
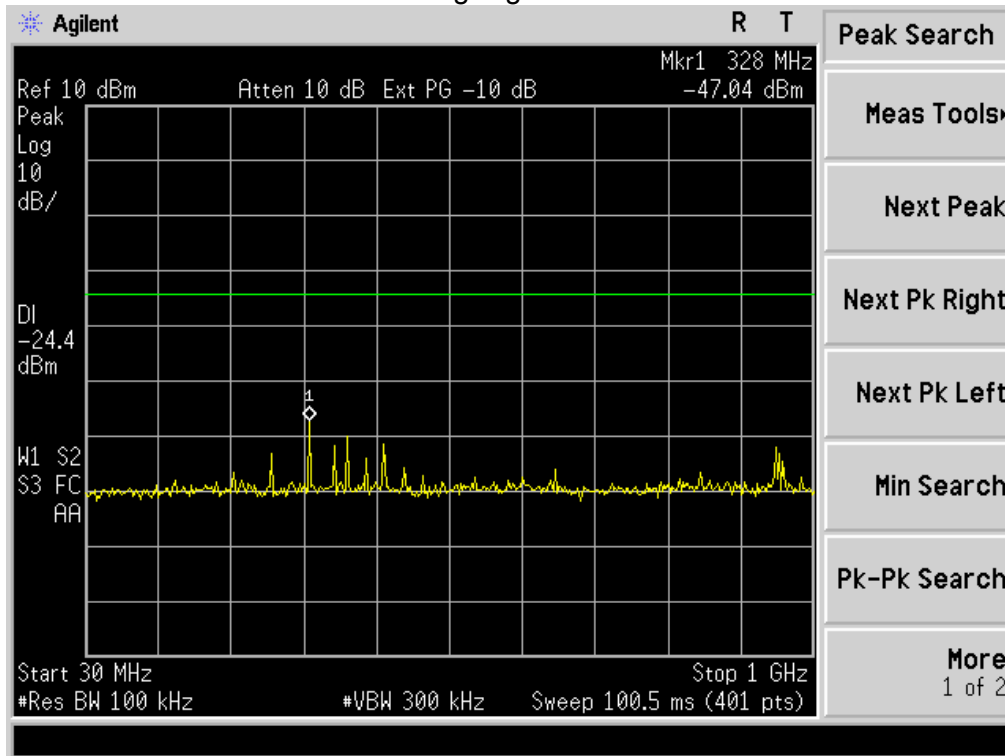

802.11n Low Channel

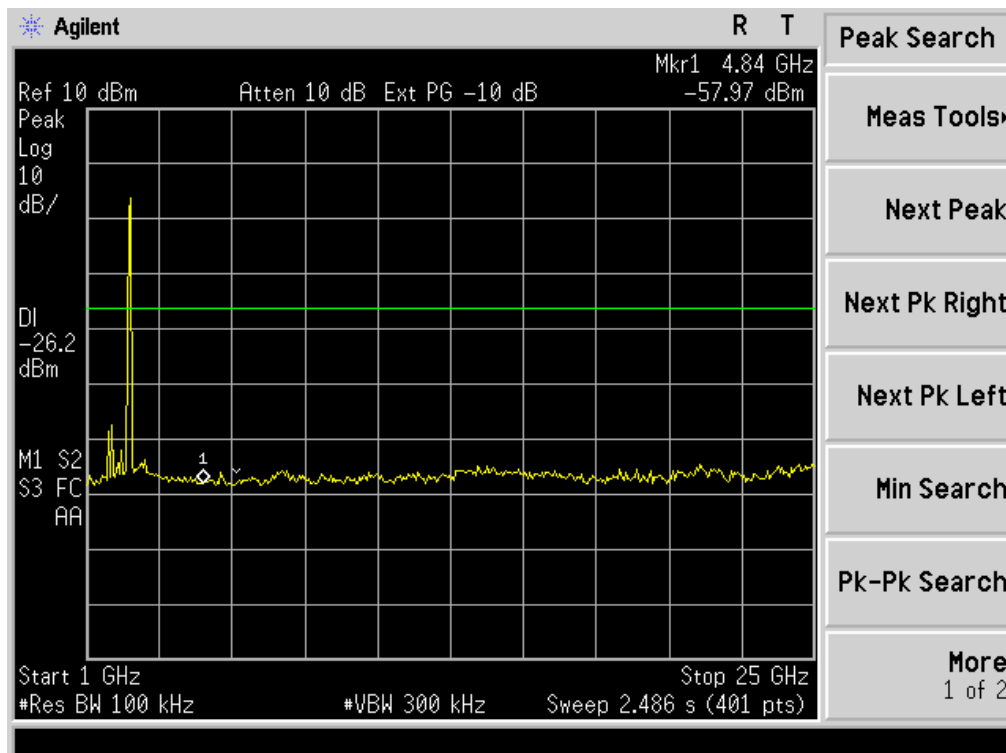
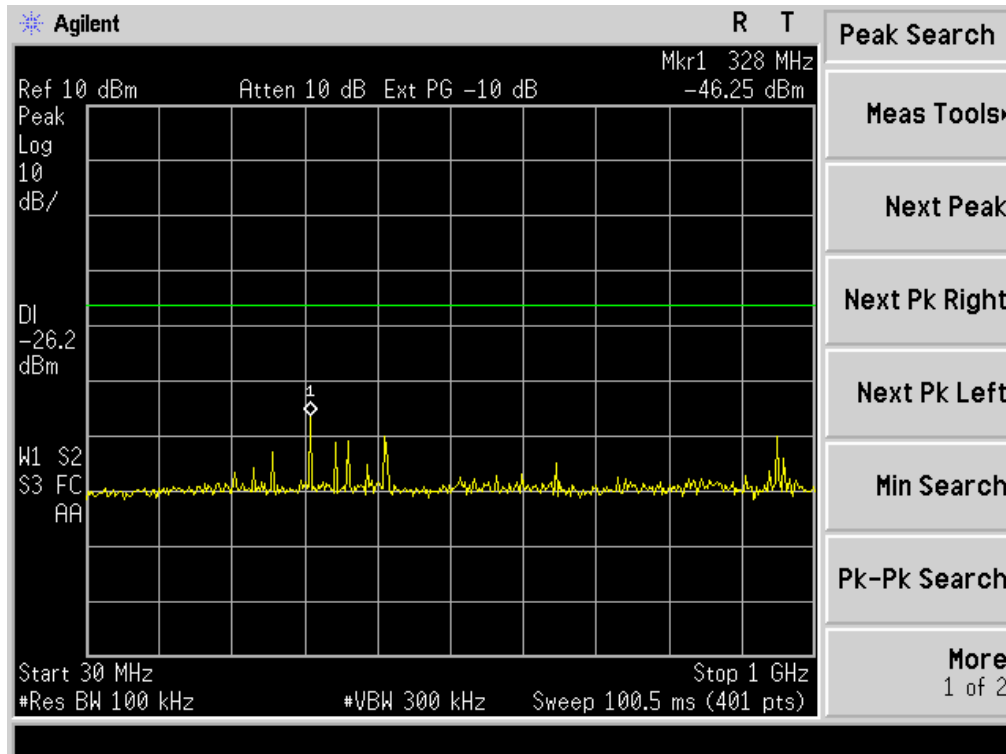

802.11n Middle Channel

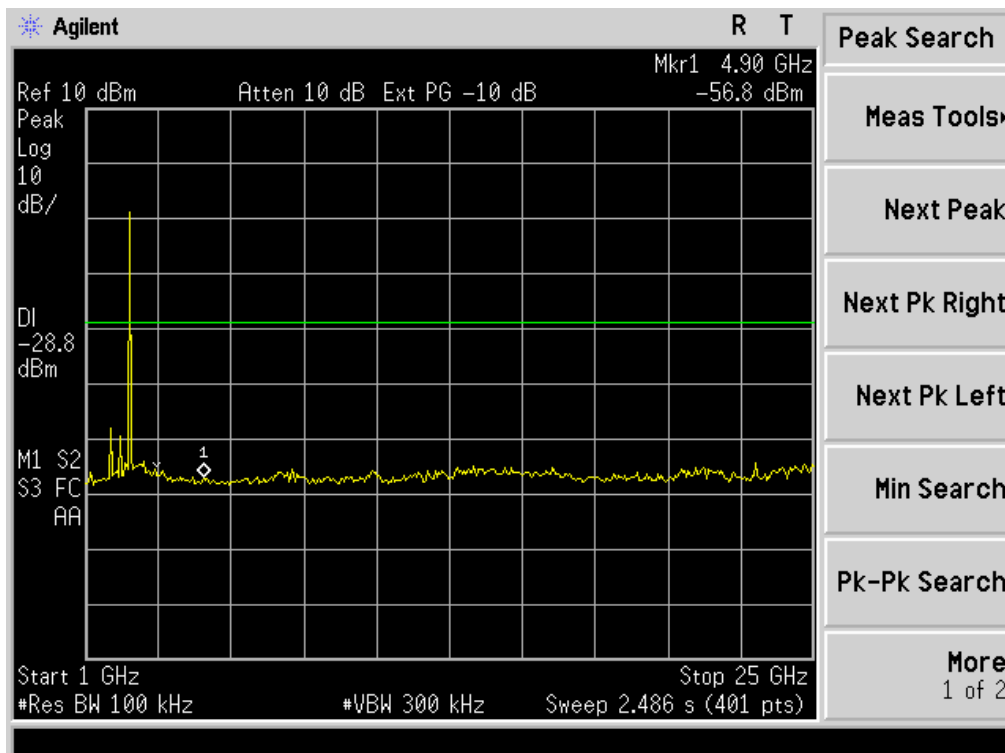
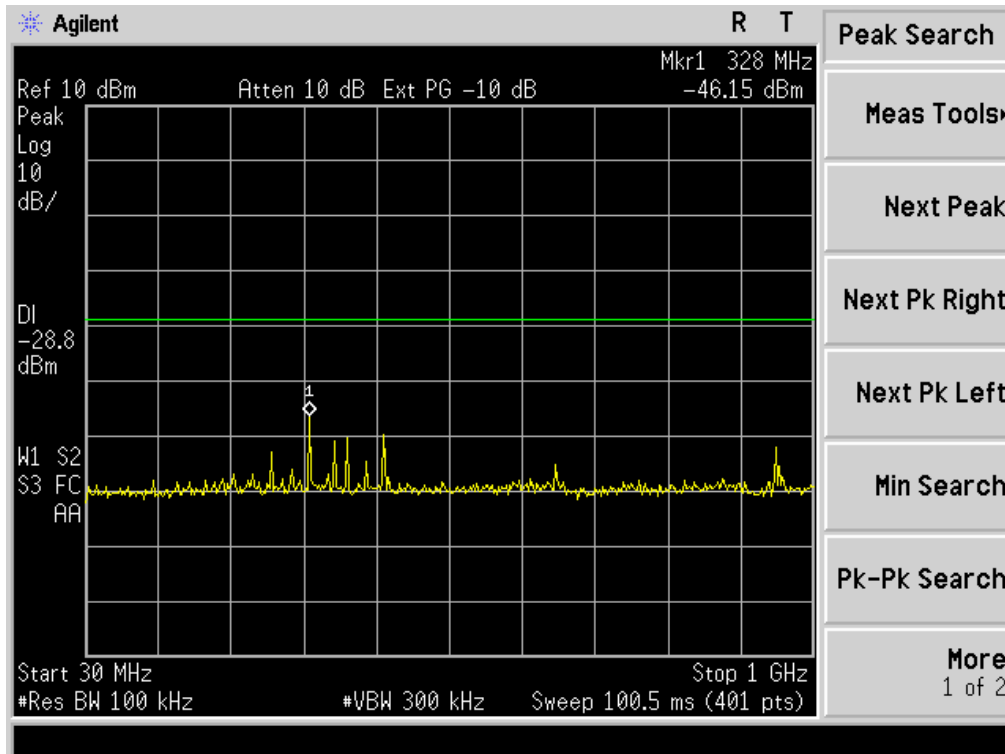

802.11n High Channel

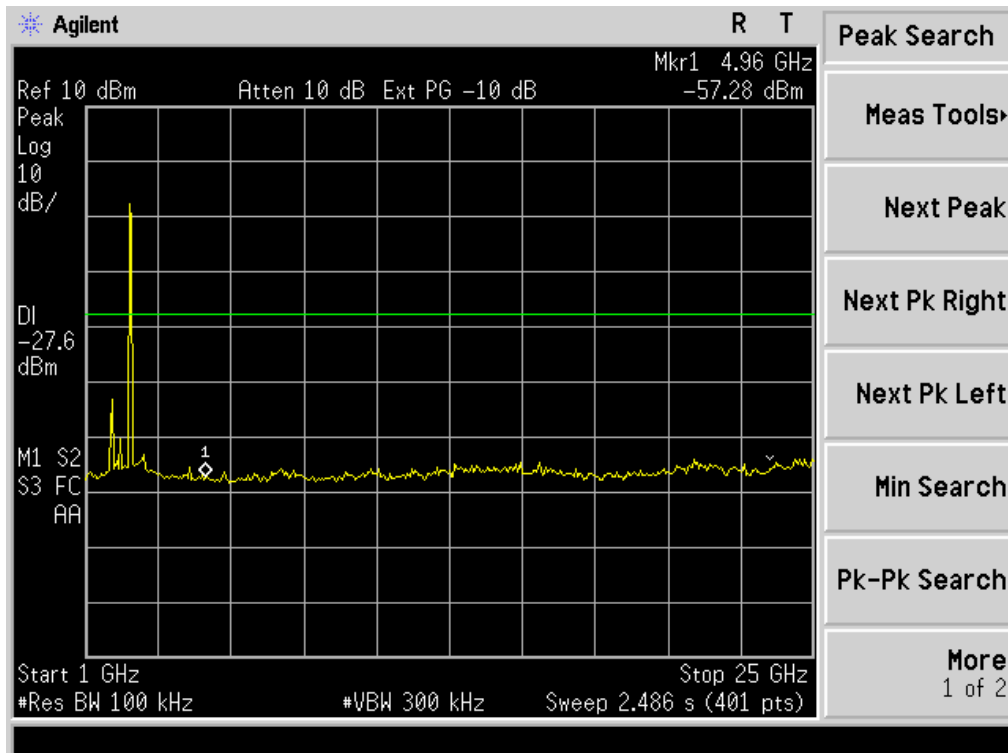
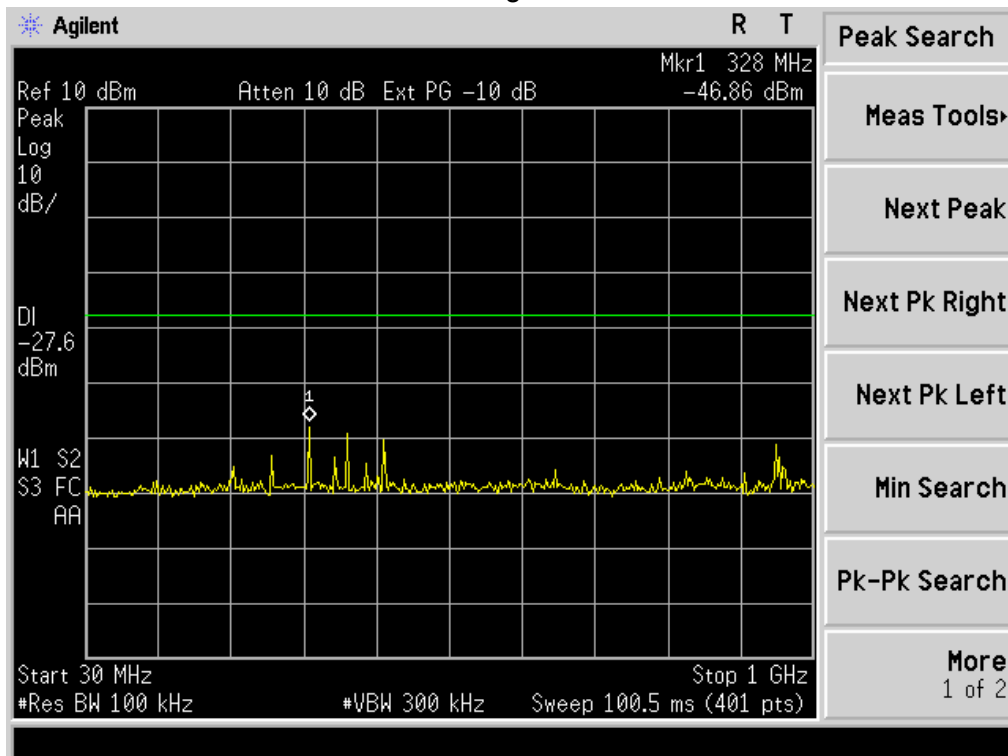

4. POWER SPECTRAL DENSITY TEST

4.1 APPLIED PROCEDURES / LIMIT

FCC Part15 (15.247) , Subpart C				
Section	Test Item	Limit	Frequency Range (MHz)	Result
15.247	Power Spectral Density	8 dBm (in any 3KHz)	2400-2483.5	PASS

4.1.1 TEST PROCEDURE

1. Set analyzer center frequency to DTS channel center frequency.
2. Set the span to 1.5 times the DTS channel bandwidth.
3. Set the RBW \geq 3 kHz.
4. Set the VBW \geq 3 x RBW.
5. Detector = peak.
6. Sweep time = auto couple.
7. Trace mode = max hold.
8. Allow trace to fully stabilize.
9. Use the peak marker function to determine the maximum amplitude level.
10. If measured value exceeds limit, reduce RBW (no less than 3 kHz) and repeat.

4.1.2 DEVIATION FROM STANDARD

No deviation.

4.1.3 TEST SETUP

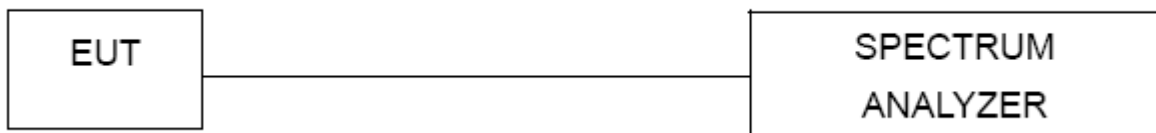

4.1.4 EUT OPERATION CONDITIONS

The EUT tested system was configured as the statements of 2.1 Unless otherwise a special operating condition is specified in the follows during the testing.

4.1.5 TEST RESULTS

EUT :	IP CAMERA	Model Name :	629W
Temperature :	25 °C	Relative Humidity :	60%
Pressure :	1015 hPa	Test Voltage :	DC 5.0V from adapter
Test Mode :	TX b Mode /CH01, CH06, CH11		

Frequency	Power Density (dBm)	Limit (dBm)	Result
2412 MHz	-15.54	8	PASS
2437 MHz	-15.77	8	PASS
2462 MHz	-17.51	8	PASS

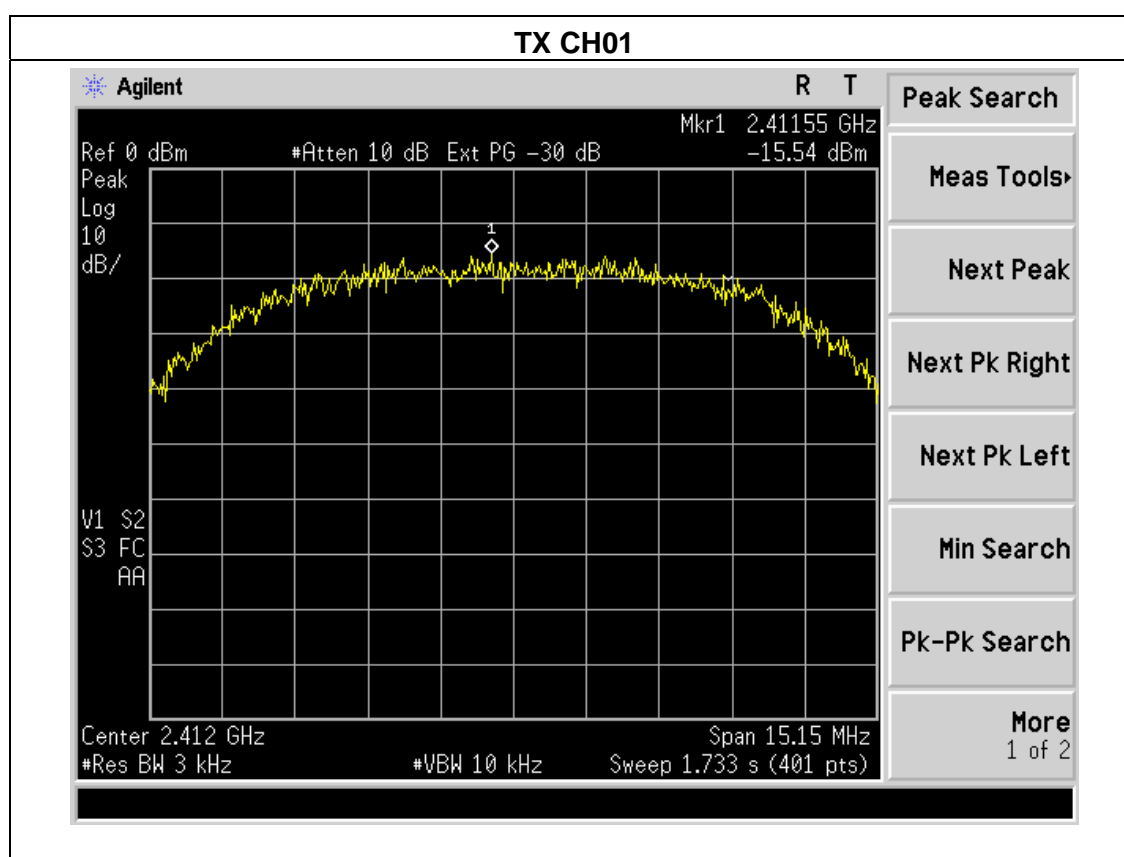

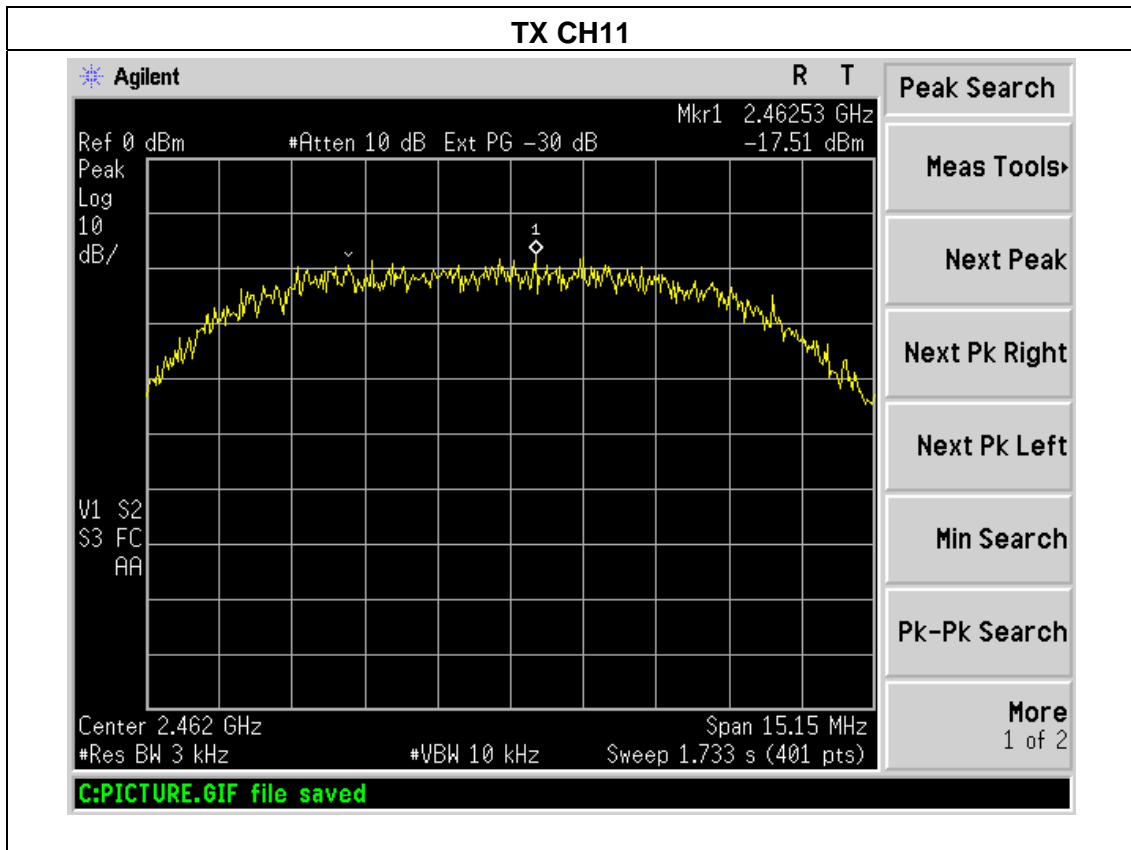
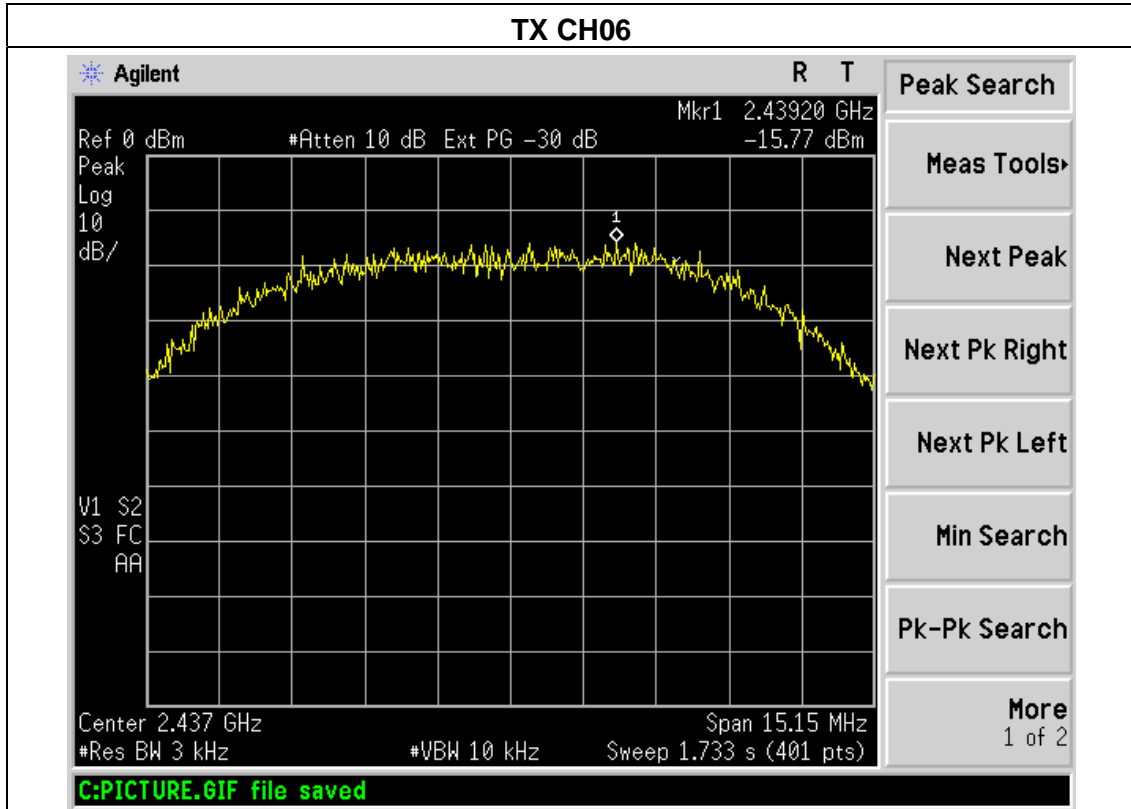

EUT :	IP CAMERA	Model Name :	629W
Temperature :	25 °C	Relative Humidity :	60%
Pressure :	1015 hPa	Test Voltage :	DC 5.0V from adapter
Test Mode :	TX g Mode /CH01, CH06, CH11		

Frequency	Power Density (dBm)	Limit (dBm)	Result
2412 MHz	-26.42	8	PASS
2437 MHz	-26.59	8	PASS
2462 MHz	-26.21	8	PASS

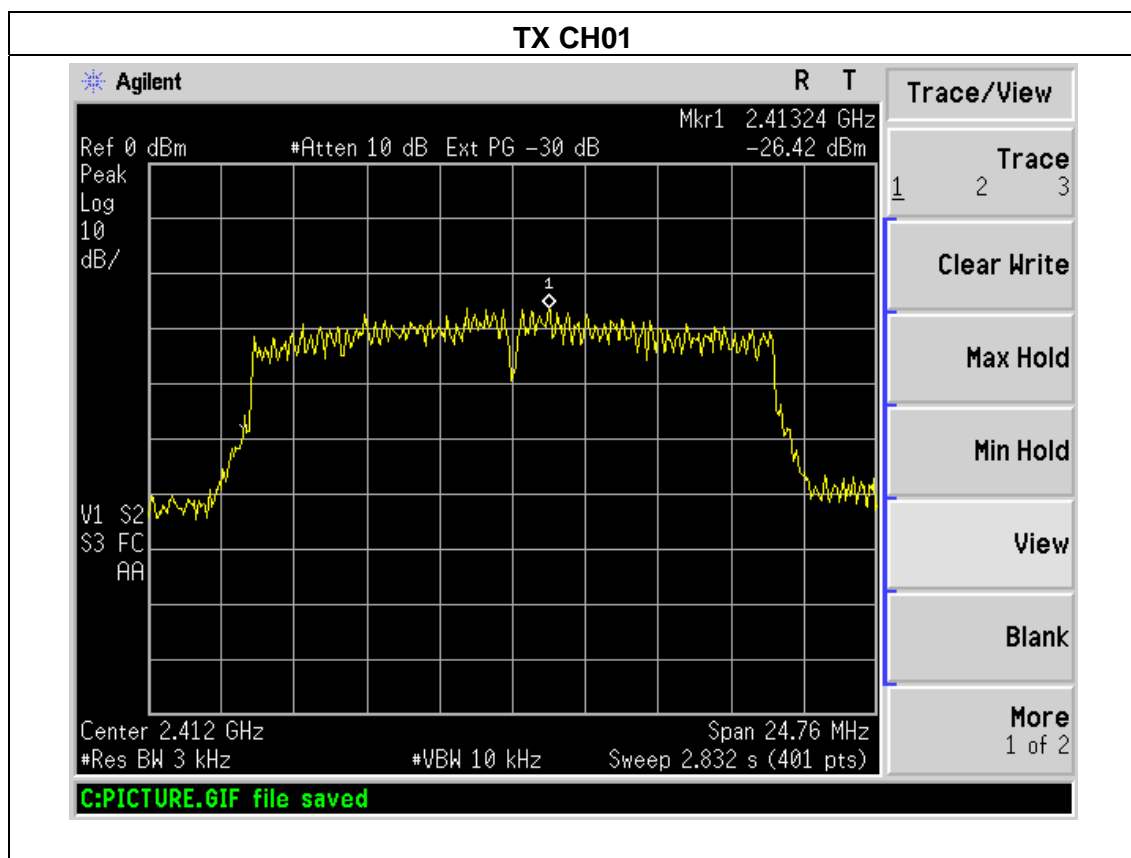

TX CH06

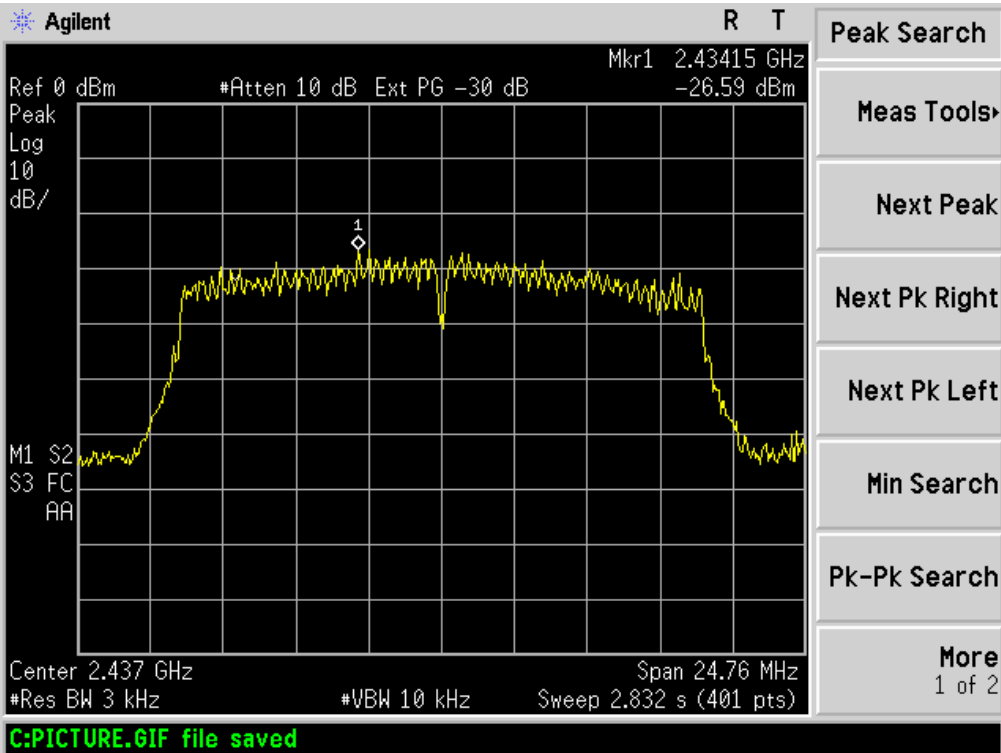

TX CH11

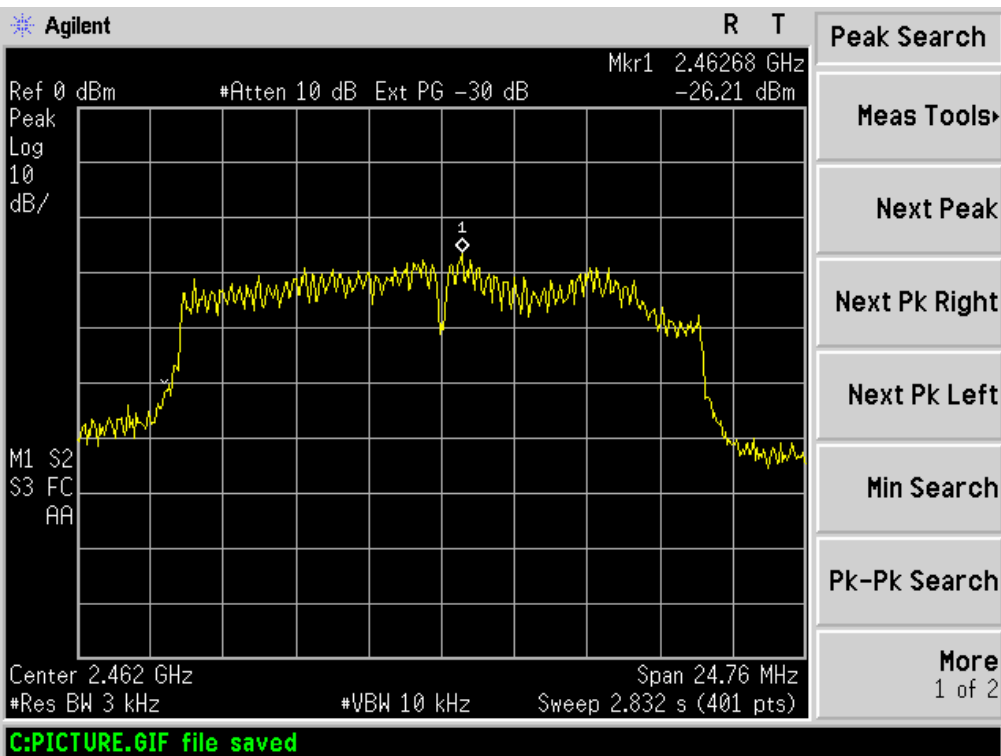

EUT :	IP CAMERA	Model Name :	629W
Temperature :	25 °C	Relative Humidity :	60%
Pressure :	1015 hPa	Test Voltage :	DC 5.0V from adapter
Test Mode :	TX n Mode /CH01, CH06, CH11		

Frequency	Power Density (dBm)	Limit (dBm)	Result
2412 MHz	-21.78	8	PASS
2437 MHz	-21.40	8	PASS
2462 MHz	-22.56	8	PASS

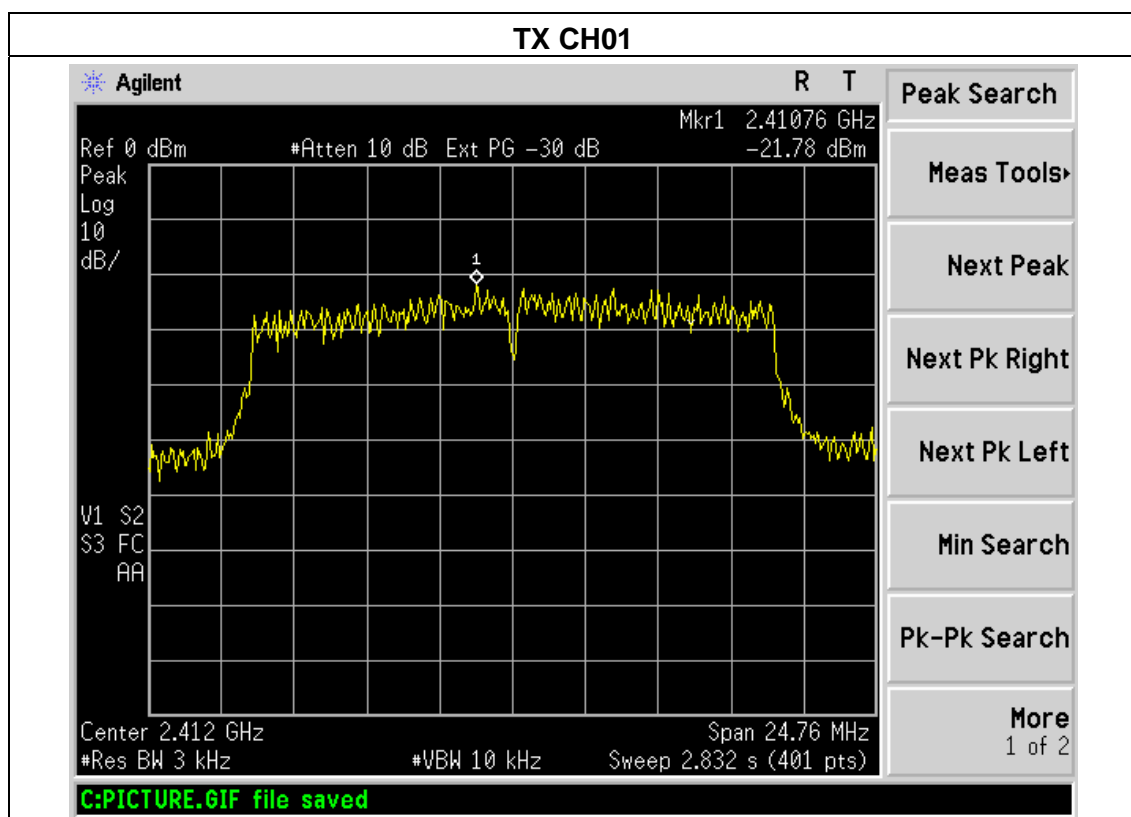

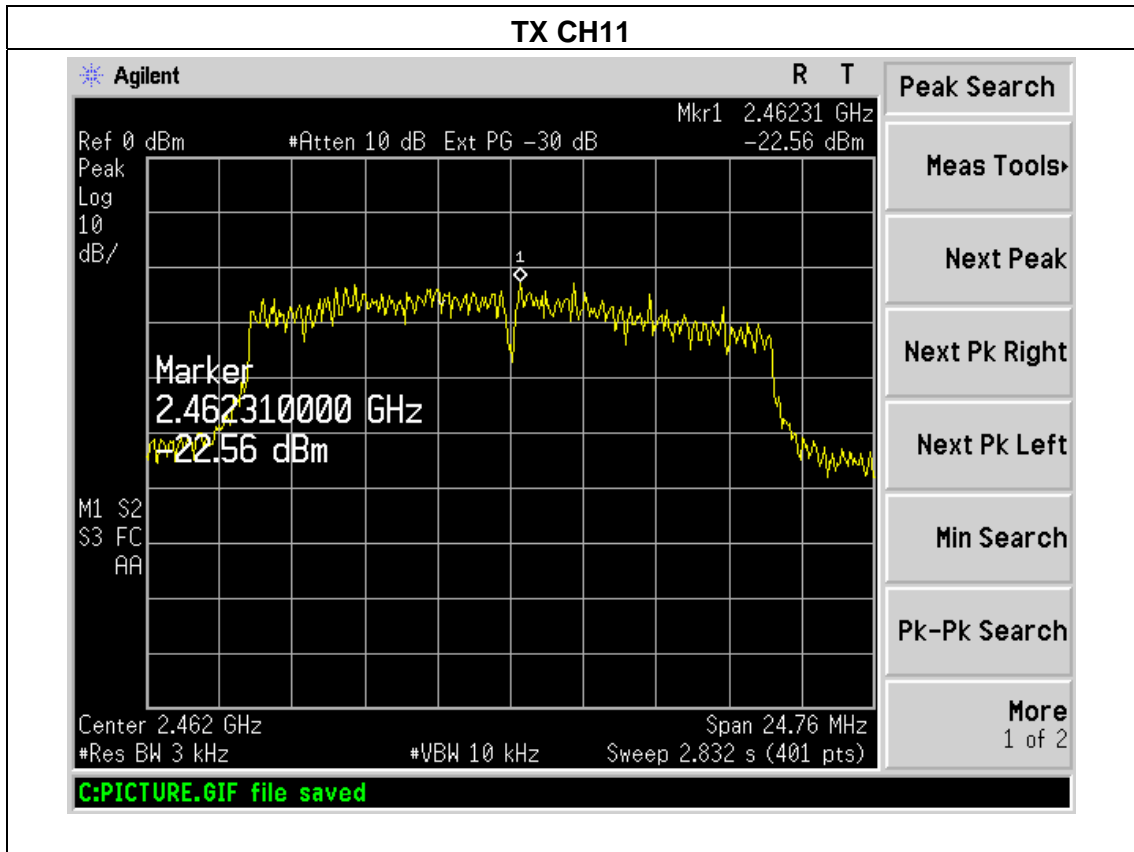
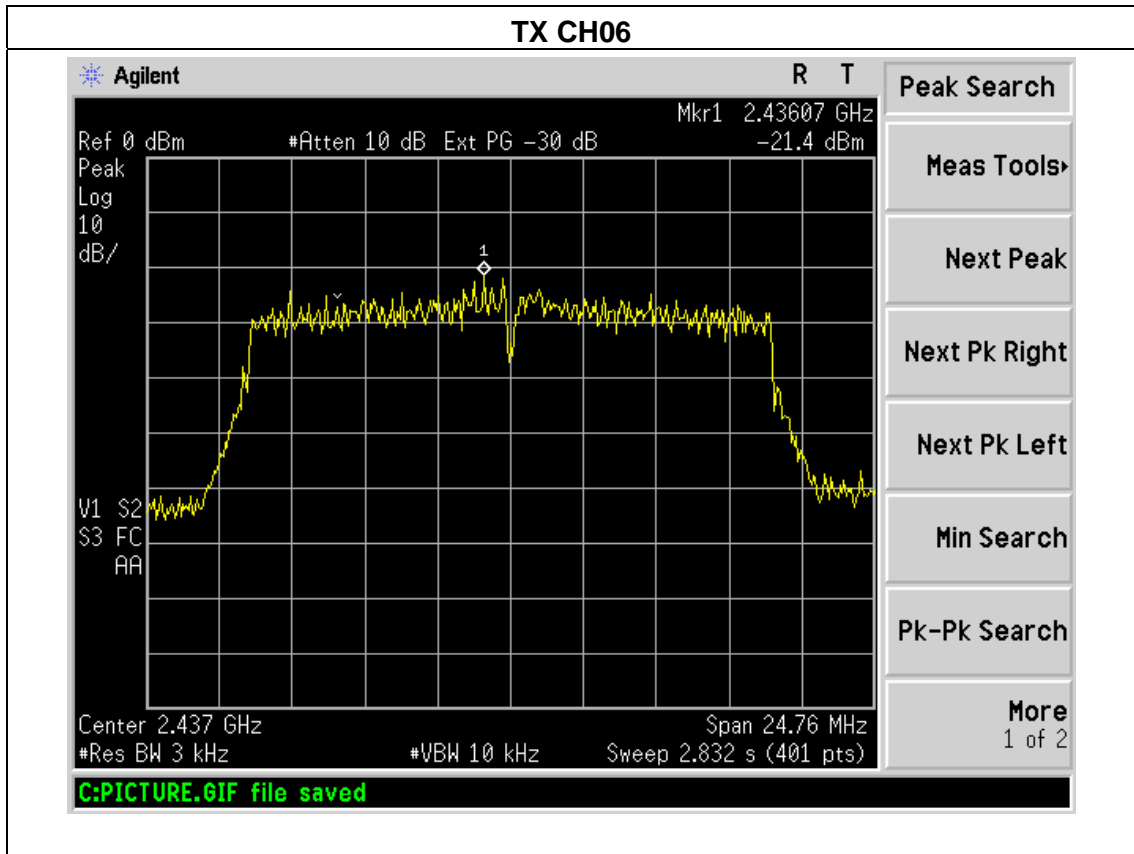

5. BANDWIDTH TEST

5.1 APPLIED PROCEDURES / LIMIT

FCC Part15 (15.247) , Subpart C				
Section	Test Item	Limit	Frequency Range (MHz)	Result
15.247(a)(2)	Bandwidth	$\geq 500\text{KHz}$ (6dB bandwidth)	2400-2483.5	PASS

5.1.1 TEST PROCEDURE

1. Set RBW= 100 kHz.
2. Set the video bandwidth (VBW) $\geq 3 \times$ RBW.
3. Detector = Peak.
4. Trace mode = max hold.
5. Sweep = auto couple.
6. Allow the trace to stabilize.
7. Measure the maximum width of the emission that is constrained by the frequencies associated with the two outermost amplitude points (upper and lower) that are attenuated by 6 dB relative to the maximum level measured in the fundamental emission.

5.1.2 DEVIATION FROM STANDARD

No deviation.

5.1.3 TEST SETUP

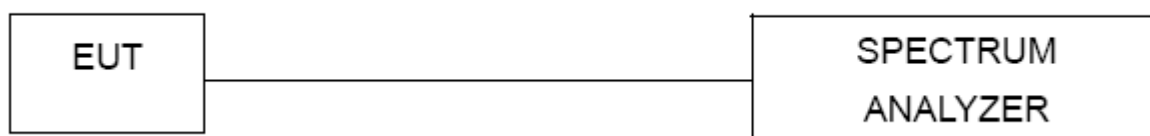

5.1.4 EUT OPERATION CONDITIONS

The EUT tested system was configured as the statements of 2.4 Unless otherwise a special operating condition is specified in the follows during the testing.

5.1.5 TEST RESULTS

EUT :	IP CAMERA	Model Name :	629W
Temperature :	25 °C	Relative Humidity :	60%
Pressure :	1012 hPa	Test Voltage :	DC 5.0V from adapter
Test Mode :	TX b Mode /CH01, CH06, CH11		

Channel	Frequency (MHz)	6dB bandwidth (MHz)	Limit (kHz)	Result
Low	2412	8.922	500	Pass
Middle	2437	8.971	500	Pass
High	2462	8.771	500	Pass

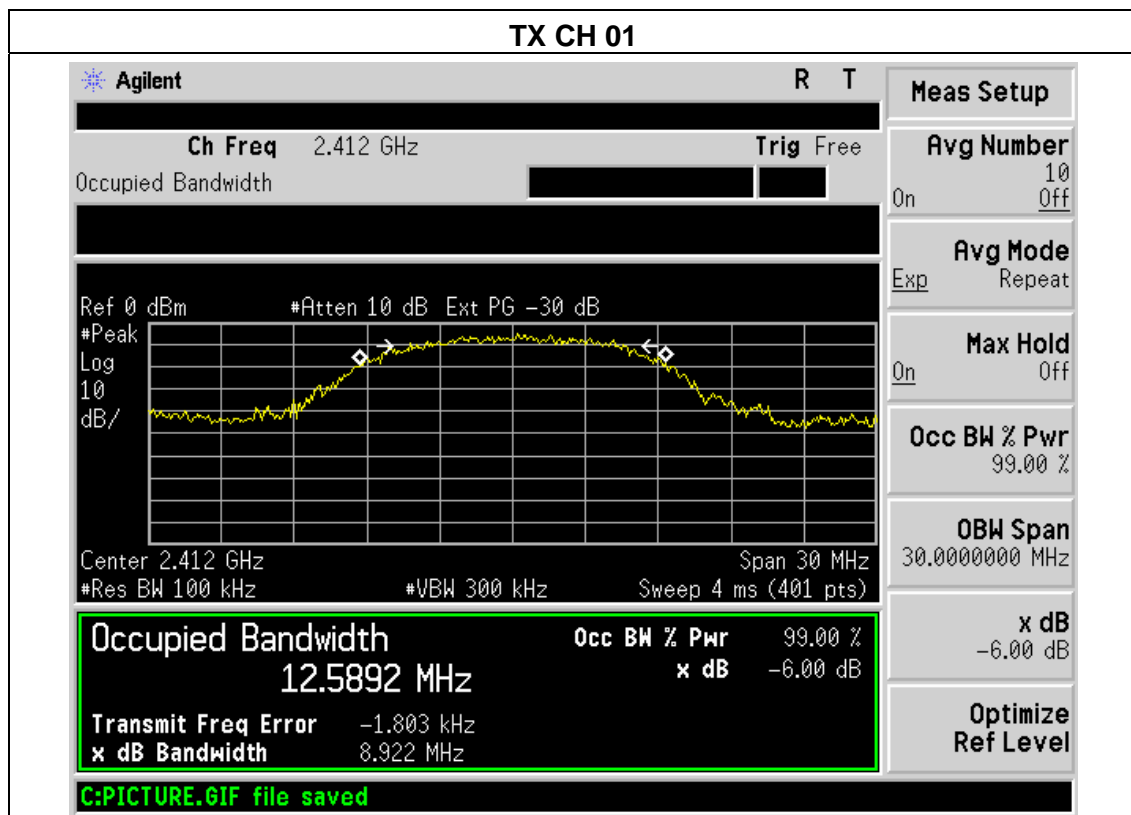

TX CH 06

Agilent
R T

Ch Freq 2.437 GHz
Trig Free

Occupied Bandwidth

Ref 10 dBm #Atten 10 dB Ext PG -30 dB

Center 2.437 GHz Span 30 MHz
#Res BW 100 kHz #VBW 300 kHz Sweep 4 ms (401 pts)

Occupied Bandwidth Occ BW % Pwr 99.00 %
12.7471 MHz x dB -6.00 dB

Transmit Freq Error -90.021 kHz
 x dB Bandwidth 8.971 MHz

C:PICTURE.GIF file saved

Trace/View

Trace 1 2 3

Clear Write

Max Hold

Min Hold

View

Blank

More 1 of 2

TX CH 11

Agilent
R T

Ch Freq 2.462 GHz
Trig Free

Occupied Bandwidth

Ref 10 dBm #Atten 10 dB Ext PG -30 dB

Center 2.462 GHz Span 30 MHz
#Res BW 100 kHz #VBW 300 kHz Sweep 4 ms (401 pts)

Occupied Bandwidth Occ BW % Pwr 99.00 %
12.3942 MHz x dB -6.00 dB

Transmit Freq Error 77.630 kHz
 x dB Bandwidth 8.771 MHz

C:PICTURE.GIF file saved

Freq/Channel

Center Freq 2.46200000 GHz

Start Freq 2.44700000 GHz

Stop Freq 2.47700000 GHz

CF Step 3.00000000 MHz
Auto Man

Freq Offset 0.00000000 Hz

Signal Track On Off

Scale Type Log Lin

EUT :	IP CAMERA	Model Name :	629W
Temperature :	25 °C	Relative Humidity :	60%
Pressure :	1012 hPa	Test Voltage :	DC 5.0V from adapter
Test Mode :	TX g Mode /CH01, CH06, CH11		

Channel	Frequency (MHz)	6dB bandwidth (MHz)	Limit (kHz)	Result
Low	2412	15.969	500	Pass
Middle	2437	17.432	500	Pass
High	2462	16.081	500	Pass

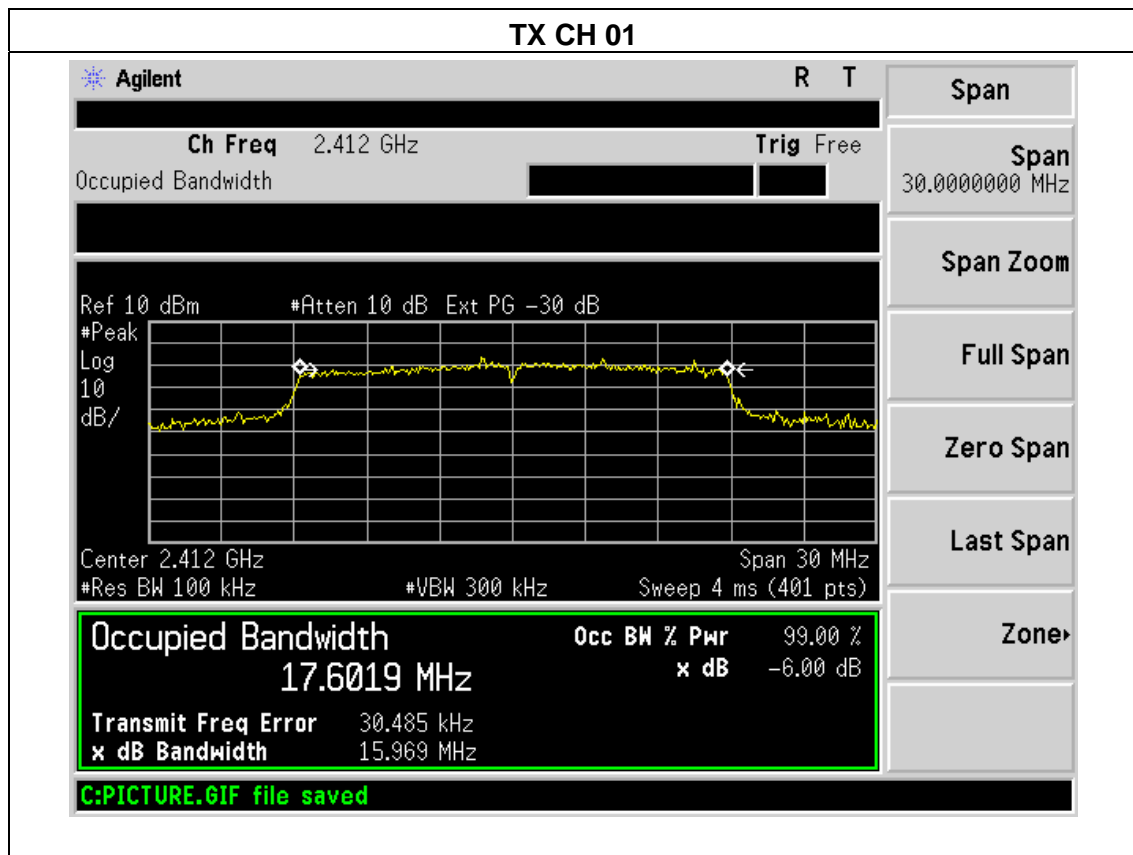

TX CH 06

Agilent R T

Ch Freq 2.437 GHz Trig Free

Occupied Bandwidth █

Center 2.437000000 GHz

Ref 10 dBm #Atten 10 dB Ext PG -30 dB

#Peak
Log
10
dB/

Center 2.437 GHz Span 30 MHz

#Res BW 100 kHz #VBW 300 kHz Sweep 4 ms (401 pts)

Occupied Bandwidth	Occ BW % Pwr	99.00 %
17.5093 MHz	x dB	-6.00 dB
Transmit Freq Error		-4.032 kHz
x dB Bandwidth		17.432 MHz

C:PICTURE.GIF file saved

Freq/Channel

Center Freq
2.43700000 GHz

Start Freq
2.42200000 GHz

Stop Freq
2.45200000 GHz

CF Step
3.00000000 MHz
Auto Man

Freq Offset
0.00000000 Hz

Signal Track
On Off

Scale Type
Log Lin

TX CH 11

Agilent R T

Ch Freq 2.462 GHz Trig Free

Occupied Bandwidth █

Center 2.462 GHz

Ref 10 dBm #Atten 10 dB Ext PG -30 dB

#Peak
Log
10
dB/

Center 2.462 GHz Span 30 MHz

#Res BW 100 kHz #VBW 300 kHz Sweep 4 ms (401 pts)

Occupied Bandwidth	Occ BW % Pwr	99.00 %
17.4602 MHz	x dB	-6.00 dB
Transmit Freq Error		21.172 kHz
x dB Bandwidth		16.081 MHz

C:PICTURE.GIF file saved

Trace/View

Trace
1 2 3

Clear Write

Max Hold

Min Hold

View

Blank

More
1 of 2

EUT :	IP CAMERA	Model Name :	629W
Temperature :	25 °C	Relative Humidity :	60%
Pressure :	1012 hPa	Test Voltage :	DC 5.0V from adapter
Test Mode :	TX n Mode /CH01, CH06, CH11		

Channel	Frequency (MHz)	6dB bandwidth (MHz)	Limit (kHz)	Result
Low	2412	15.921	500	Pass
Middle	2437	16.535	500	Pass
High	2462	17.905	500	Pass

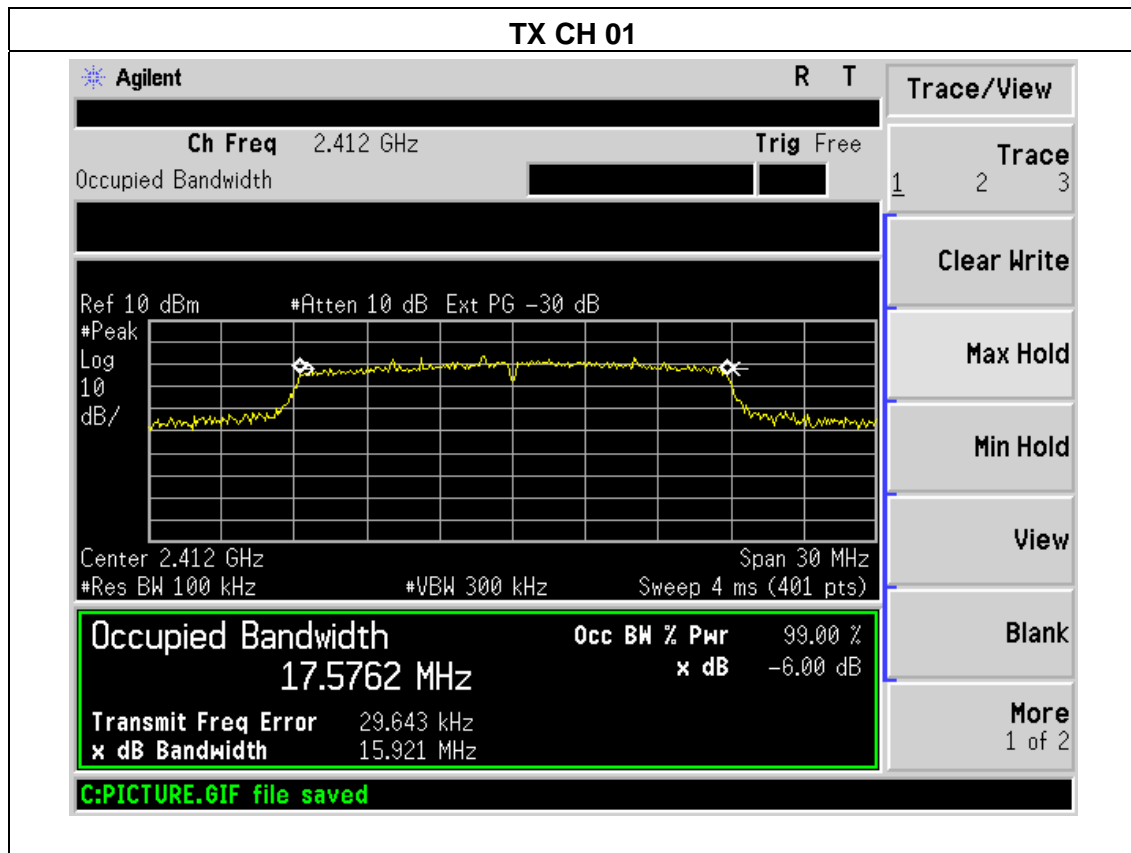

TX CH 06

Agilent
R T

Ch Freq 2.437 GHz
Trig Free

Occupied Bandwidth 1 2 3

Ref 10 dBm #Atten 10 dB Ext PG -30 dB

Center 2.437 GHz Span 30 MHz
 #Res BW 100 kHz #VBW 300 kHz Sweep 4 ms (401 pts)

Occupied Bandwidth	Occ BW % Pwr	99.00 %
17.5186 MHz	x dB	-6.00 dB
Transmit Freq Error	2.205 kHz	
x dB Bandwidth	16.535 MHz	

C:PICTURE.GIF file saved

Trace/View

Trace 1 2 3

Clear Write

Max Hold

Min Hold

View

Blank

More 1 of 2

TX CH 11

Agilent
R T

Ch Freq 2.462 GHz
Trig Free

Occupied Bandwidth 1 2 3

Ref 10 dBm #Atten 10 dB Ext PG -30 dB

Center 2.462 GHz Span 30 MHz
 #Res BW 100 kHz #VBW 300 kHz Sweep 4 ms (401 pts)

Occupied Bandwidth	Occ BW % Pwr	99.00 %
17.4103 MHz	x dB	-6.00 dB
Transmit Freq Error	-19.024 kHz	
x dB Bandwidth	17.095 MHz	

C:PICTURE.GIF file saved

Trace/View

Trace 1 2 3

Clear Write

Max Hold

Min Hold

View

Blank

More 1 of 2

6. PEAK OUTPUT POWER TEST

6.1 APPLIED PROCEDURES / LIMIT

FCC Part15 (15.247) , Subpart C				
Section	Test Item	Limit	Frequency Range (MHz)	Result
15.247(b)(3)	Peak Output Power	1 watt or 30dBm	2400-2483.5	PASS

6.1.1 TEST PROCEDURE

- a. The EUT was directly connected to the Power meter

6.1.2 DEVIATION FROM STANDARD

No deviation.

6.1.3 TEST SETUP



6.1.4 EUT OPERATION CONDITIONS

The EUT tested system was configured as the statements of 2.4 Unless otherwise a special operating condition is specified in the follows during the testing.

6.1.5 TEST RESULTS

EUT :	IP CAMERA	Model Name :	629W
Temperature :	25 °C	Relative Humidity :	60%
Pressure :	1012 hPa	Test Voltage :	DC 5.0V from adapter
Test Mode :	TX b/g/n Mode /CH01, CH06, CH11		

TX 802.11b Mode				
Test Channel	Frequency	Maximum Conducted Output Power(PK)	Maximum Conducted Output Power(AV)	LIMIT
	(MHz)	(dBm)	(dBm)	dBm
CH01	2412	17.44	15.89	30
CH06	2437	17.25	15.67	30
CH11	2462	17.09	15.44	30
TX 802.11g Mode				
CH01	2412	14.42	11.42	30
CH06	2437	14.23	11.21	30
CH11	2462	14.08	11.54	30
TX 802.11n Mode				
CH01	2412	14.23	11.67	30
CH06	2437	14.24	11.45	30
CH11	2462	14.22	11.97	30

7. 100 KHZ BANDWIDTH OF FREQUENCY BAND EDGE

APPLICABLE STANDARD

In any 100 kHz bandwidth outside the frequency band in which the spread spectrum or digitally modulated intentional radiator is operating, the radio frequency power that is produced by the intentional radiator shall be at least 20 dB below that in the 100 kHz bandwidth within the band that contains the highest level of the desired power, based on either an RF conducted or a radiated measurement, provided the transmitter demonstrates compliance with the peak conducted power limits. If the transmitter complies with the conducted power limits based on the use of RMS averaging over a time interval, as permitted under paragraph (b)(3) of this section, the attenuation required under this paragraph shall be 30 dB instead of 20 dB. Attenuation below the general limits specified in §15.209(a) is not required. In addition, radiated emissions which fall in the restricted bands, as defined in §15.205(a), must also comply with the radiated emission limits specified in §15.209(a) (see §15.205(c)).

TEST PROCEDURE

- a) Check the calibration of the measuring instrument using either an internal calibrator or a known signal from an external generator.
- b) Position the EUT without connection to measurement instrument. Turn on the EUT and connect its antenna terminal to measurement instrument via a low loss cable. Then set it to any one measured frequency within its operating range, and make sure the instrument is operated in its linear range.
- c) Set RBW to 100 kHz and VBW of spectrum analyzer to 300 kHz with a convenient frequency span including 100 kHz bandwidth from band edge.
- d) Measure the highest amplitude appearing on spectral display and set it as a reference level. Plot the graph with marking the highest point and edge frequency.
- e) Repeat above procedures until all measured frequencies were complete.

7.1 DEVIATION FROM STANDARD

No deviation.

7.2 TEST SETUP

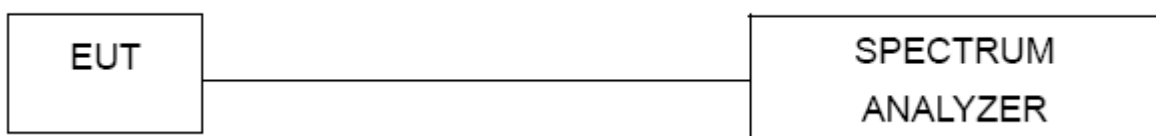

7.3 EUT OPERATION CONDITIONS

The EUT tested system was configured as the statements of 2.4 Unless otherwise a special operating condition is specified in the follows during the testing.

7.4 TEST RESULTS

EUT :	IP CAMERA	Model Name :	629W
Temperature :	25 °C	Relative Humidity :	60%
Pressure :	1012 hPa	Test Voltage :	DC 5.0V from adapter

Frequency Band	Delta Peak to band emission (dBc)	> Limit (dBc)	Result
802.11b mode			
Left-band	57.54	20	Pass
Right-band	31.83	20	Pass
802.11g mode			
Left-band	35.09	20	Pass
Right-band	32.69	20	Pass
802.11n mode			
Left-band	37.91	20	Pass
Right-band	34.18	20	Pass

BandEdge at Antenna Port:

802.11b: Band Edge, Left Side

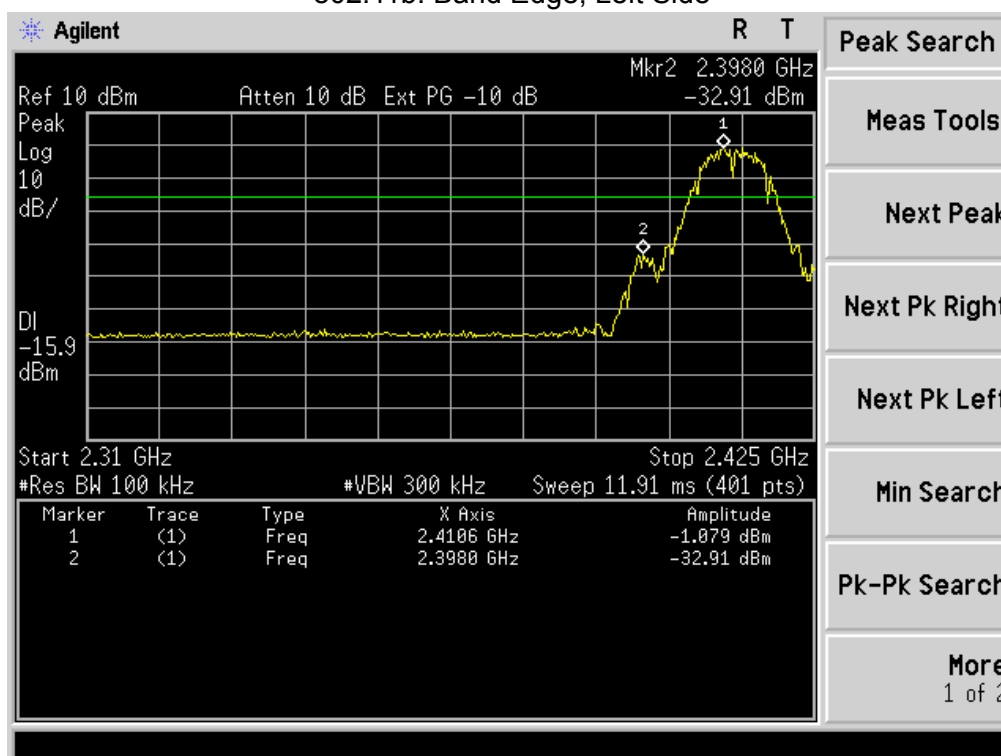

802.11b: Band Edge, Right Side

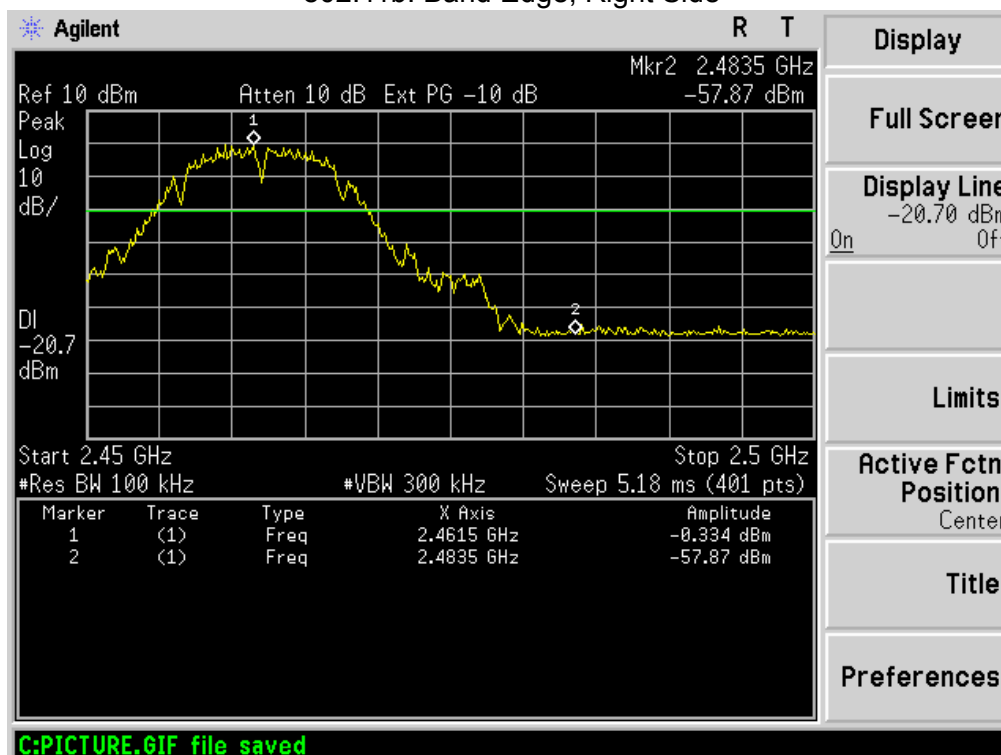

802.11g: Band Edge, Left Side

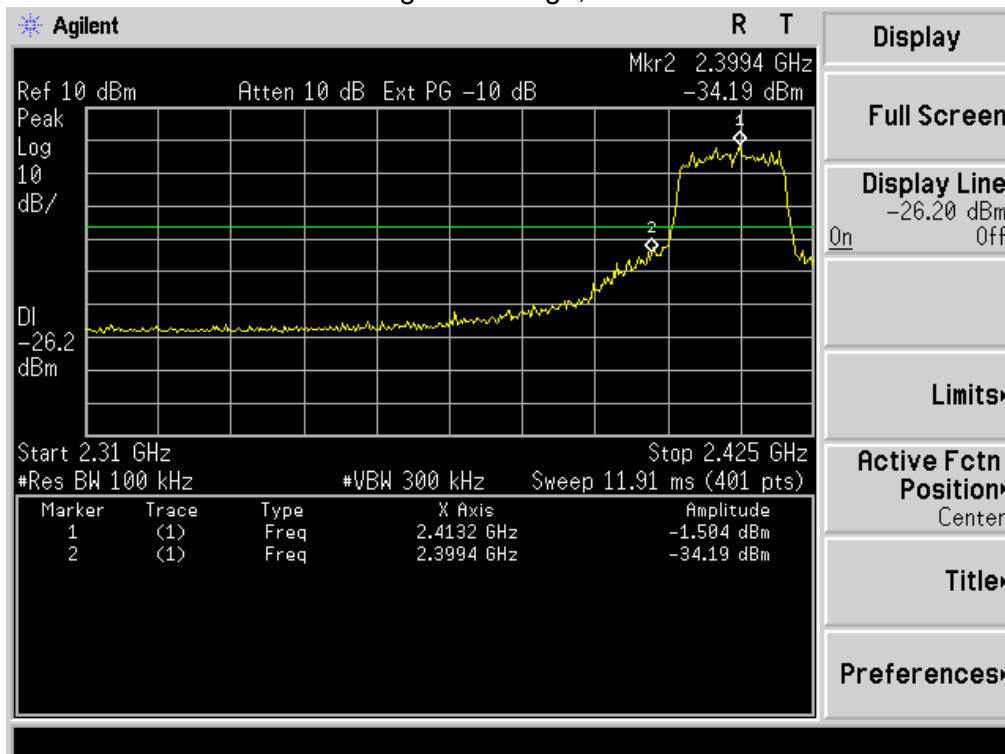

802.11g: Band Edge, Right Side

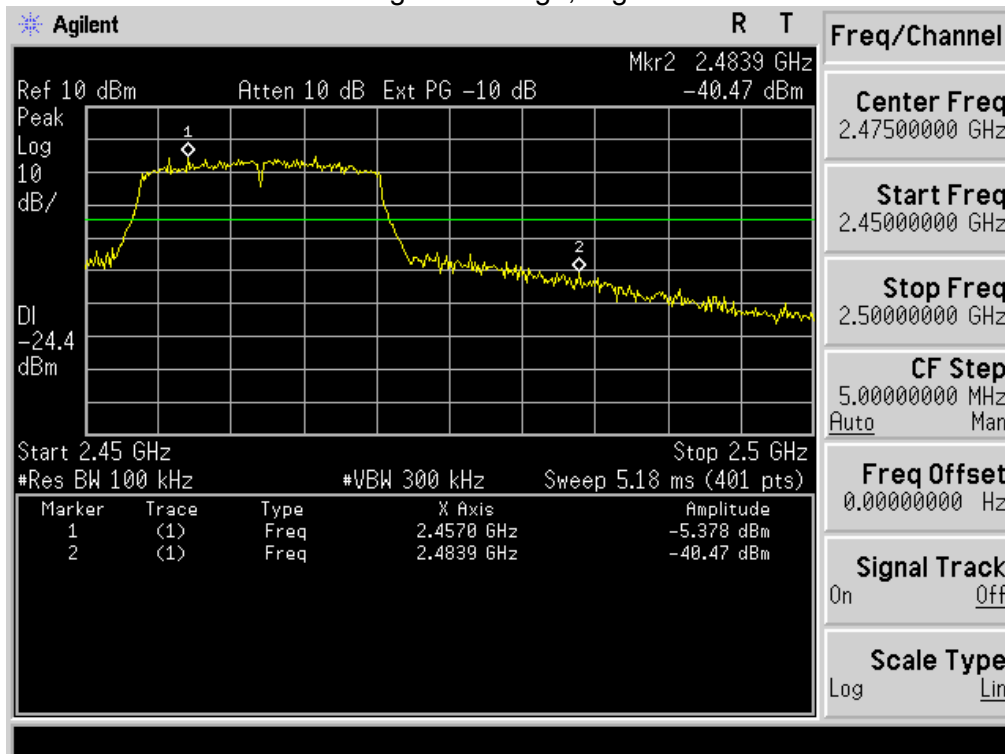

802.11n: Band Edge, Left Side

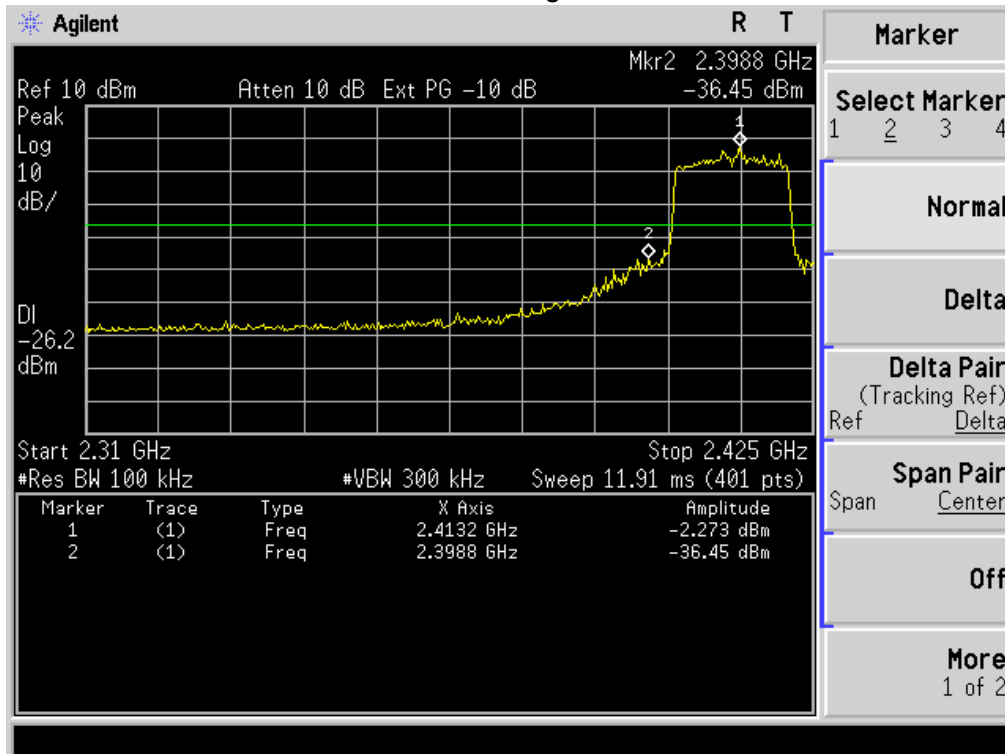

802.11n: Band Edge, Right Side

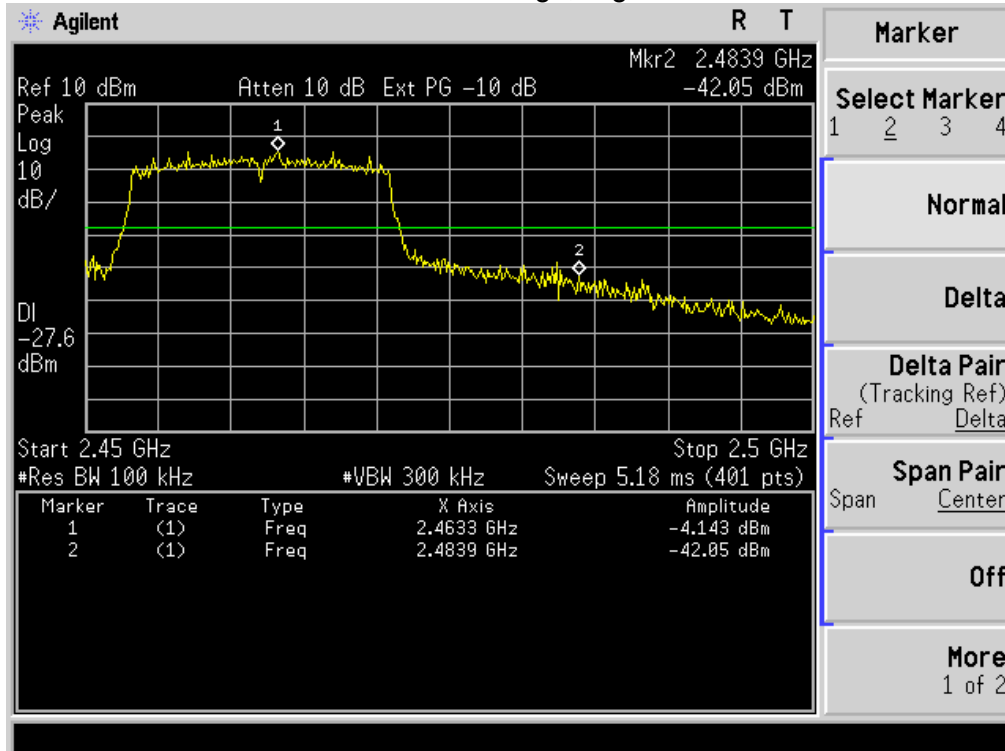

8. ANTENNA REQUIREMENT

8.1 STANDARD REQUIREMENT

15.203 requirement: For intentional device, according to 15.203: an intentional radiator shall be designed to ensure that no antenna other than that furnished by the responsible party shall be used with the device.

8.2 EUT ANTENNA

The EUT antenna is Integrated(FPCB) antenna. It comply with the standard requirement.

9. EUT TEST PHOTO

Radiated Measurement Photos

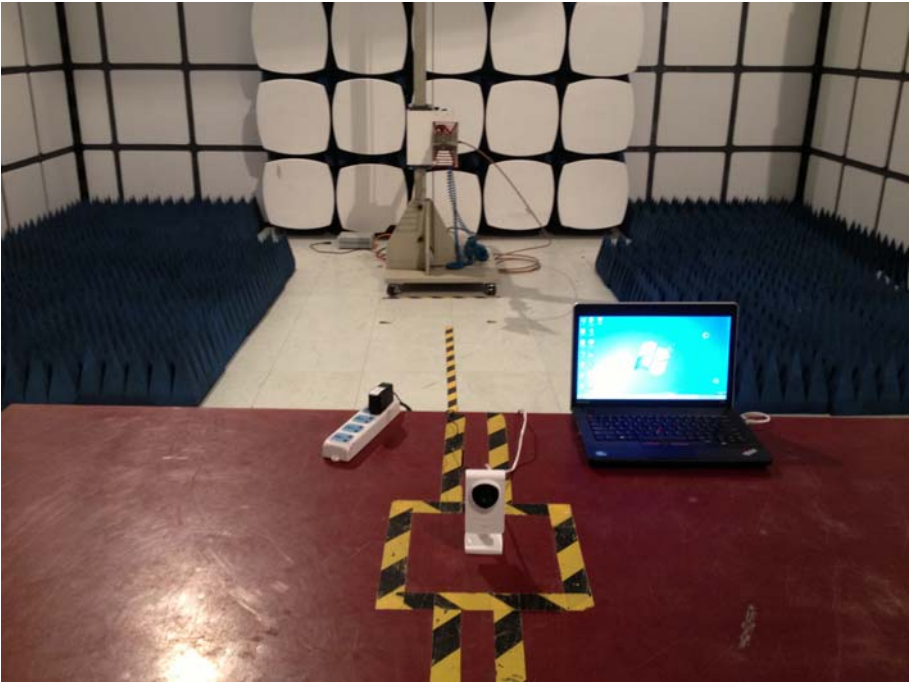
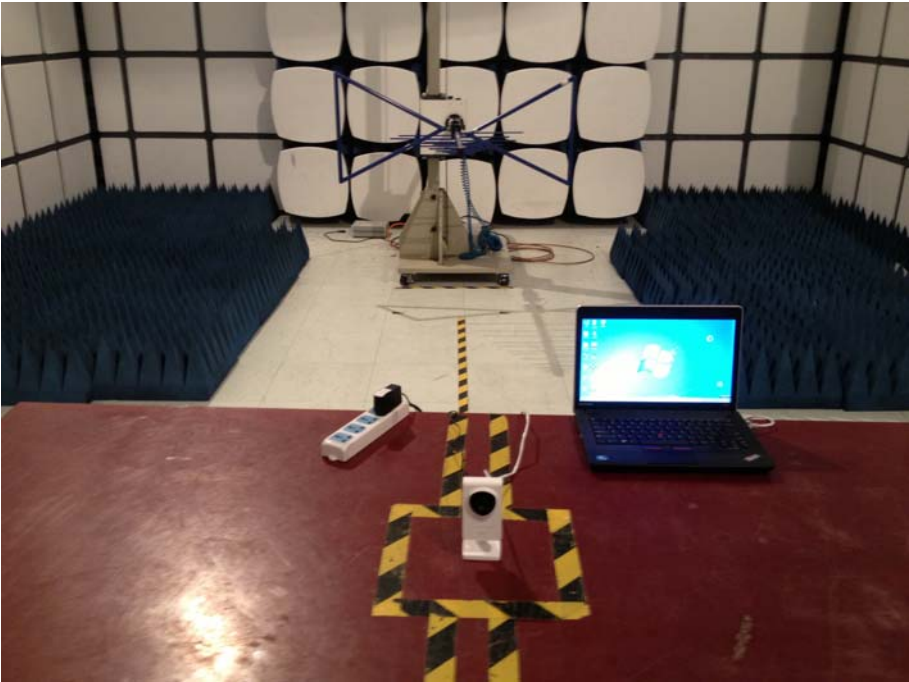

Conducted Measurement Photos

