

[4] GPIO11_USBFLG
PAGE 1. 5

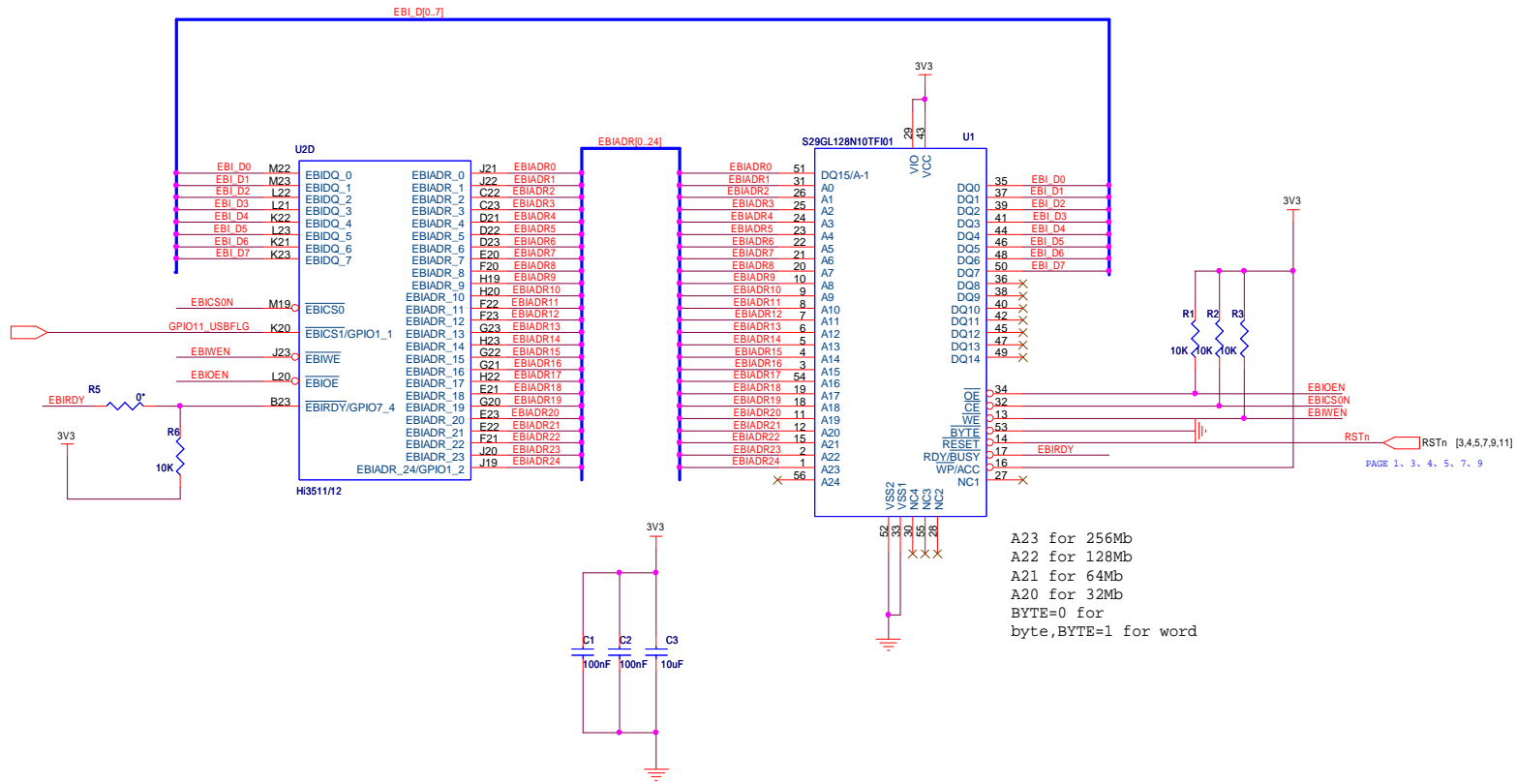

A23 for 256Mb
A22 for 128Mb
A21 for 64Mb
A20 for 32Mb
BYTE=0 for
byte, BYTE=1 for word

Title			<Title>
Size	Document Number	Rev	
A3	<Doc>	<RevCode>	
Date:	Wednesday, January 19, 2011	Sheet	1 of 12

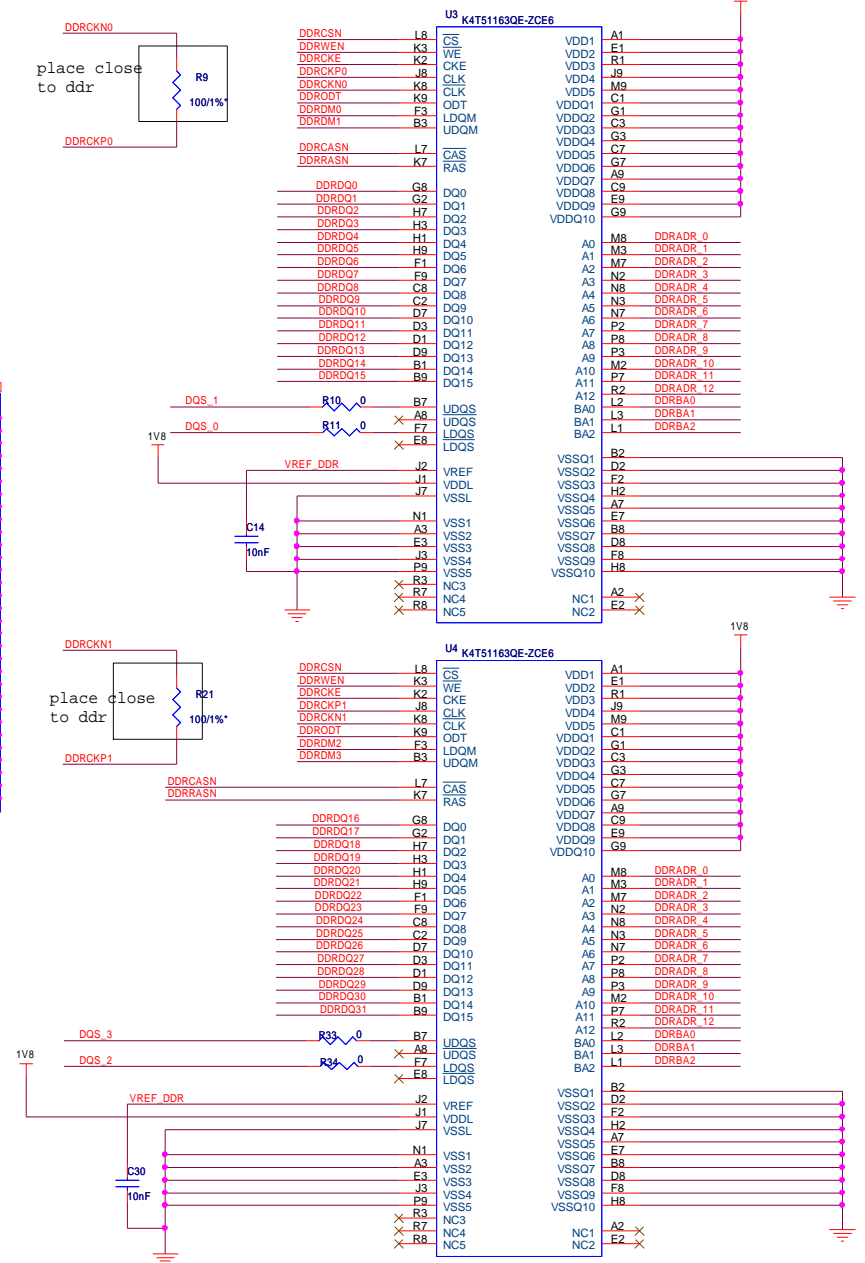
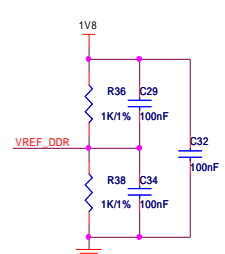
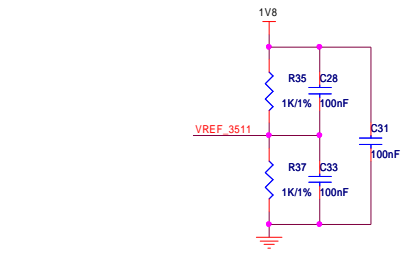
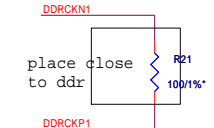
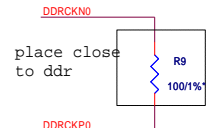
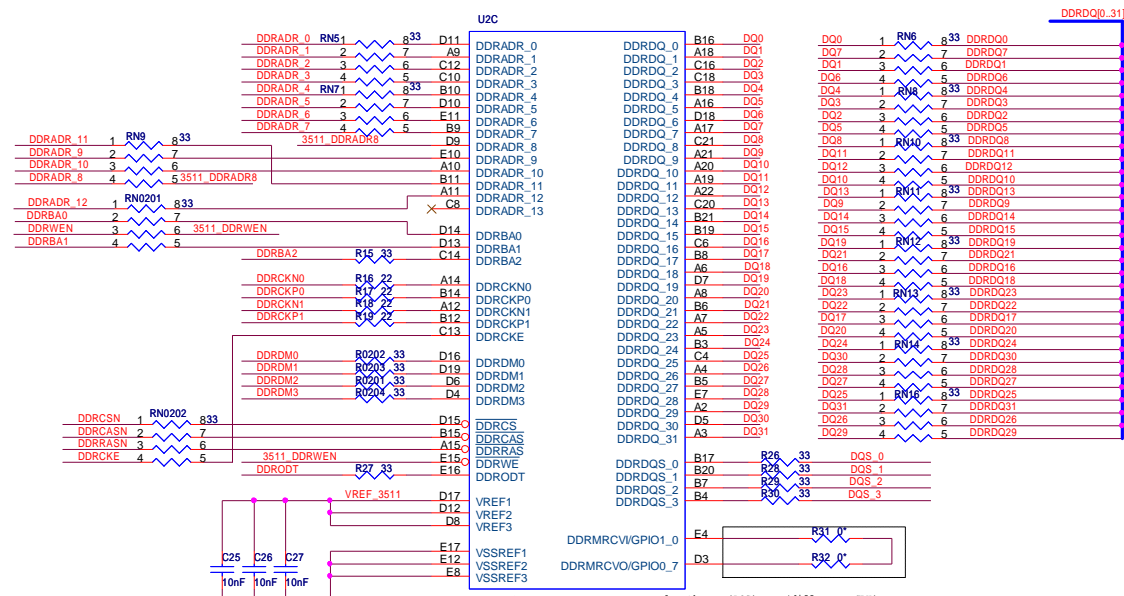
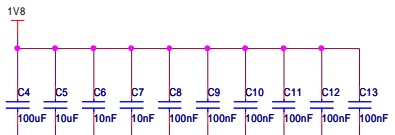
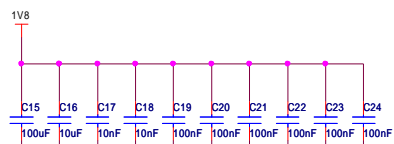

BA2 for 1Gb
16bits only
for Hi3512

Title	<Title>	
Size	Document Number	Rev
A3	<Doc>	<Rev Code>
Date:	Wednesday, April 14, 2010	Sheet 2 of 12

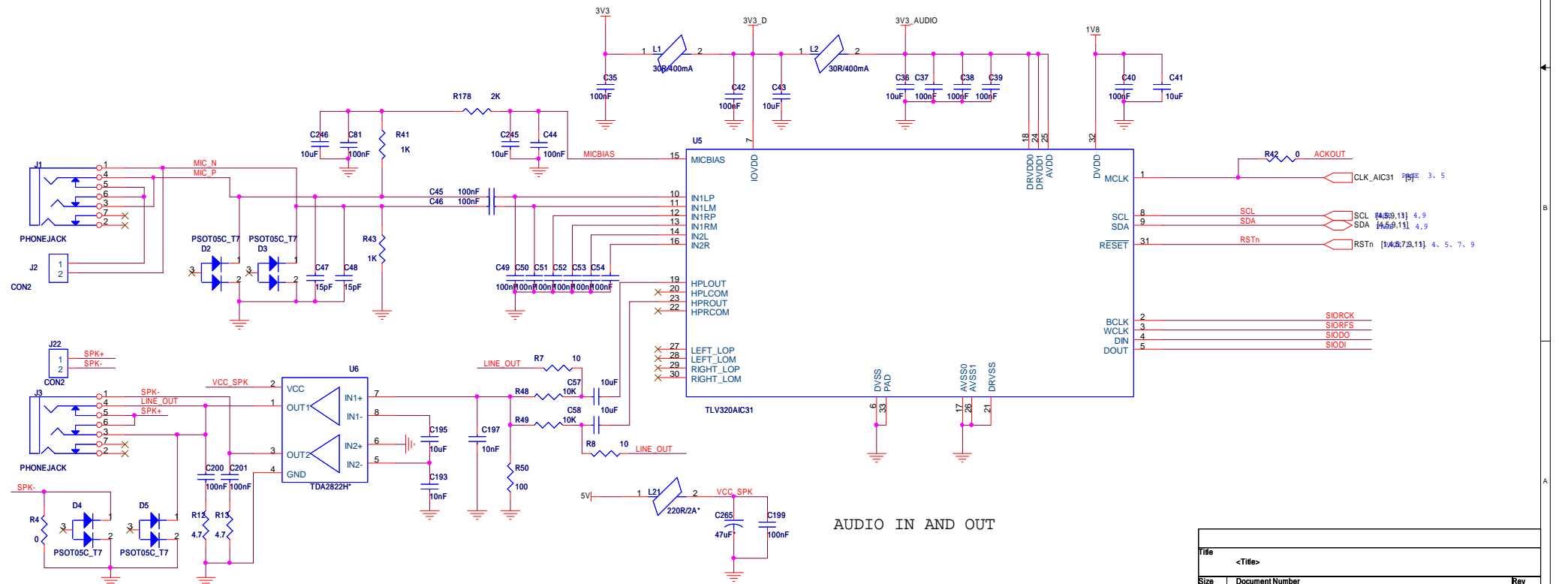
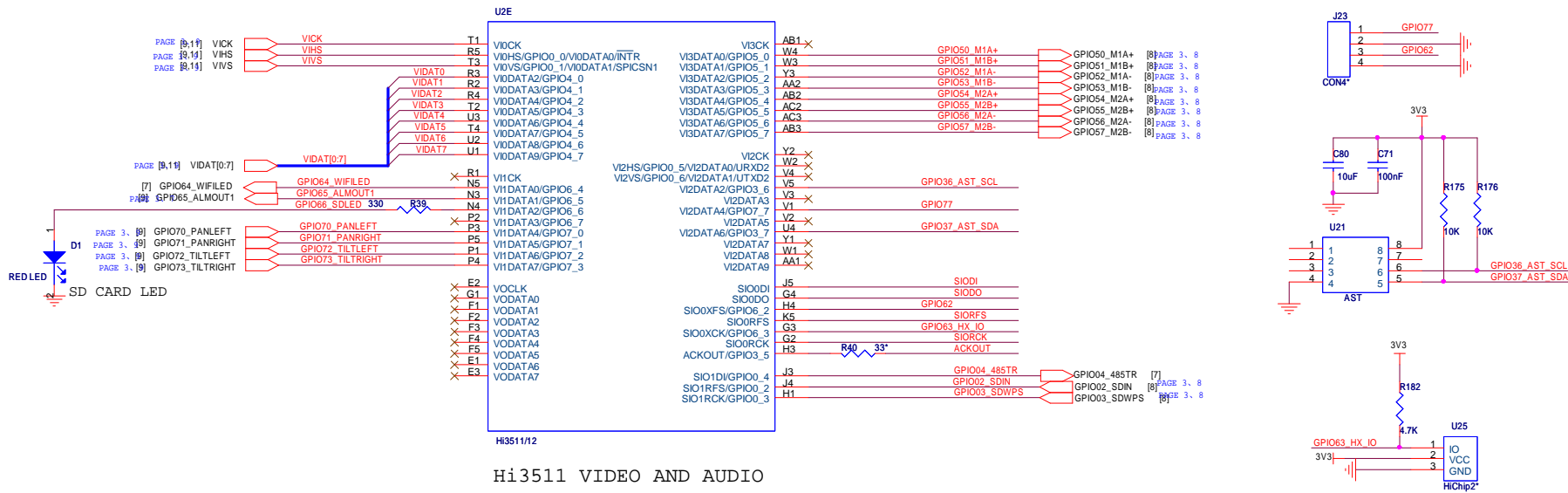

Title	<Title>	
Size	Document Number	Rev
A3	<Doc>	<RevCode>
Date:	Saturday, April 23, 2011	Sheet 3 of 12

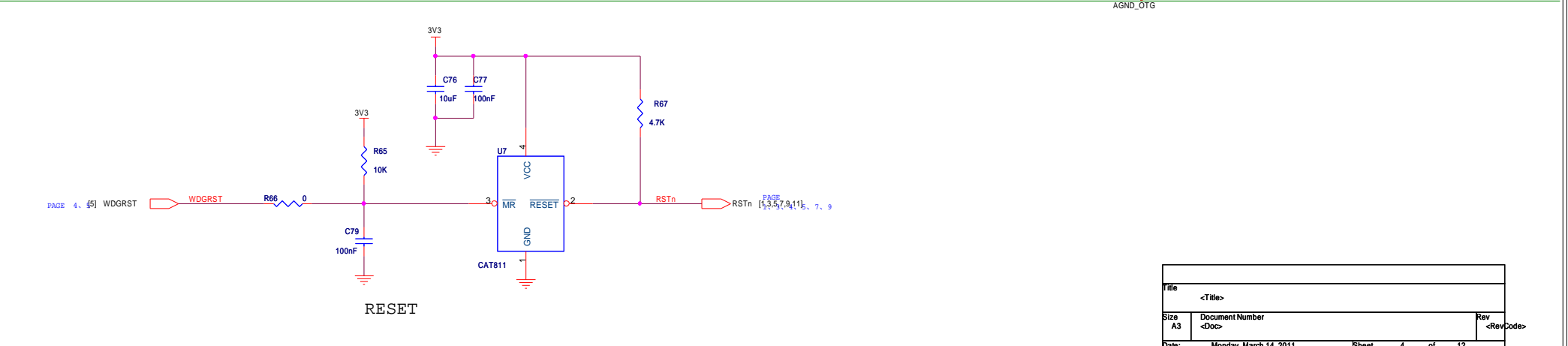
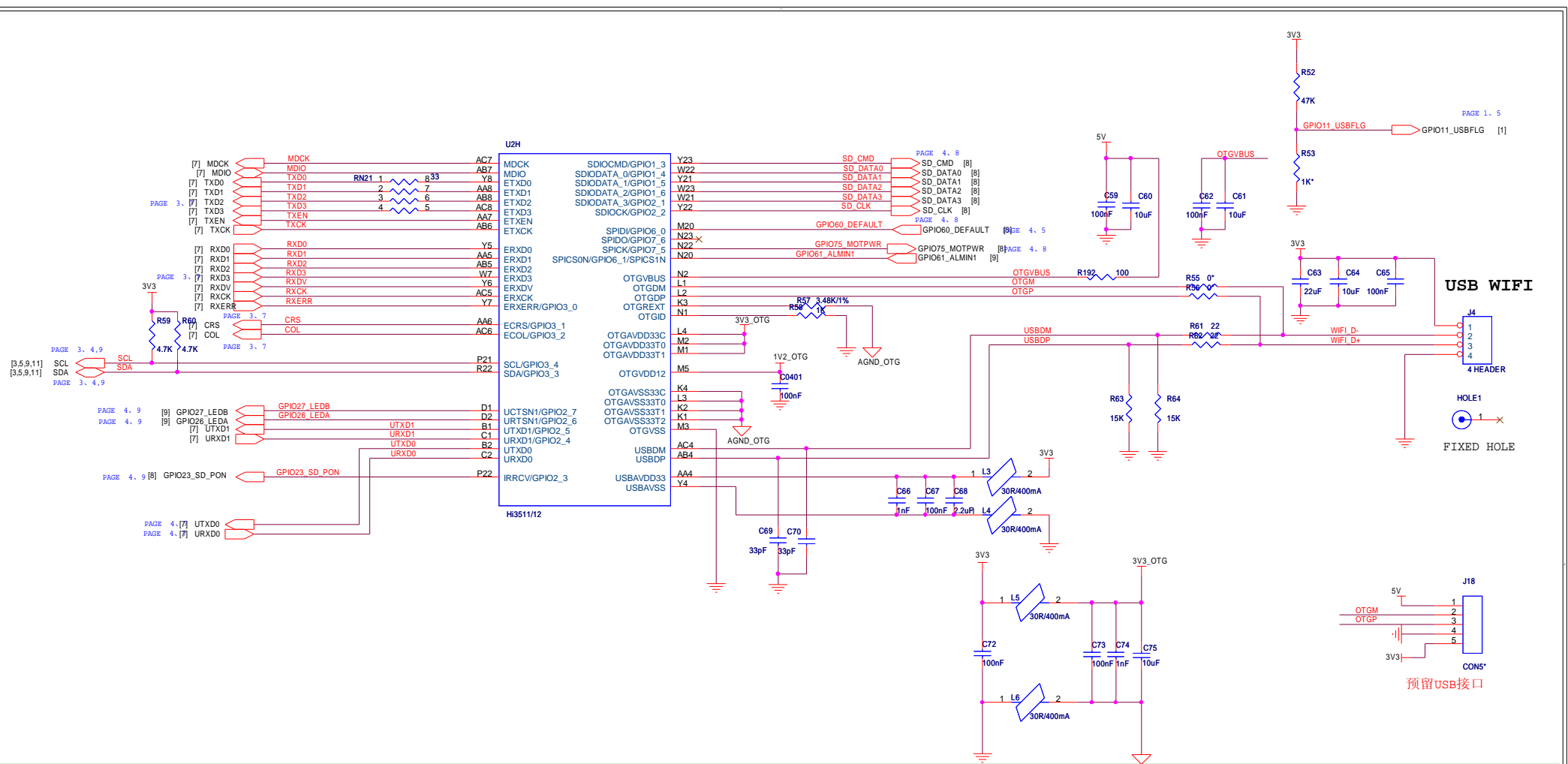

File		
<Title>		
Size	Document Number	Rev
A3	<Doc>	<RevCode>
Date:	Monday, March 14, 2011	Sheet 4 of 12

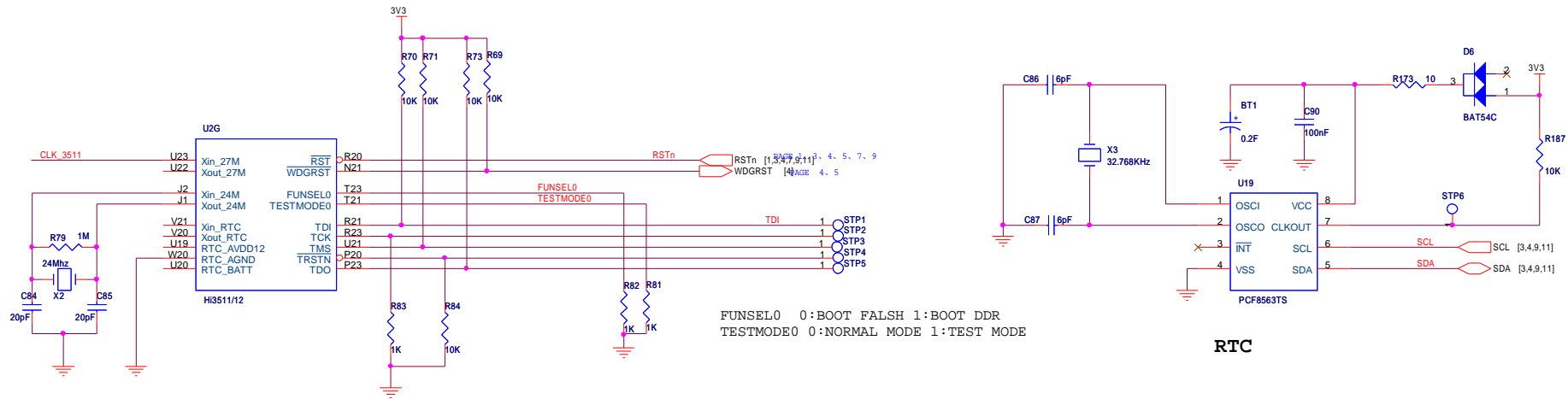

Hi3511 CLK AND JTAG

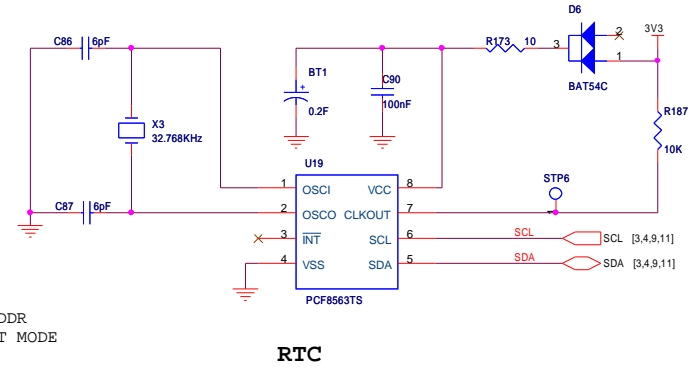

RTC

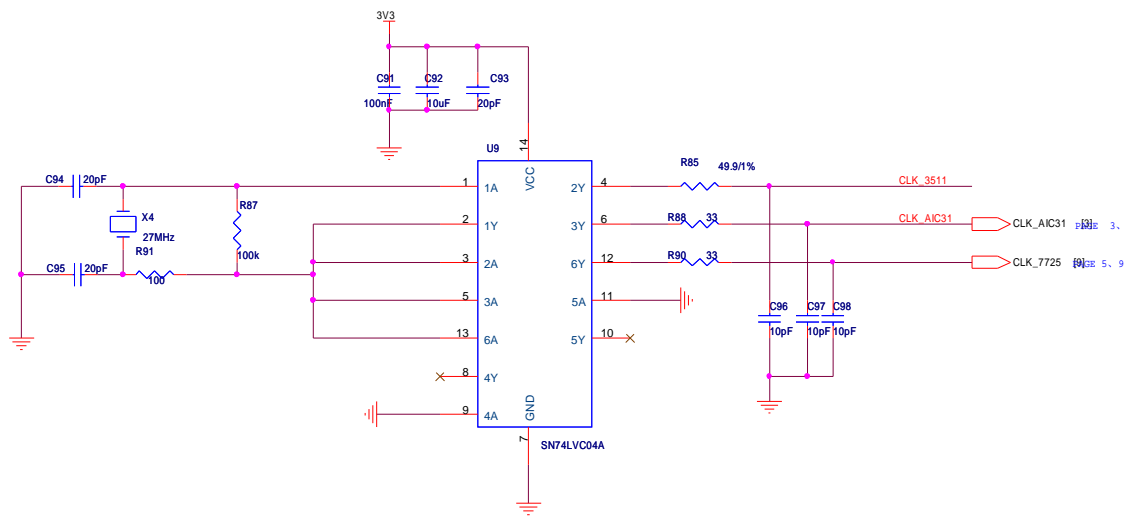

CLOCK

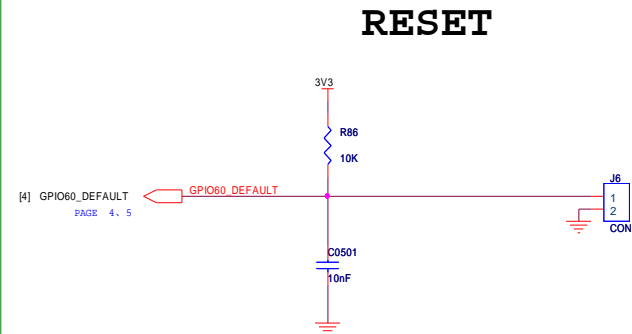

RESET

DEFAULT

Title		
<Title>		
Size	Document Number	Rev
A3	<Doc>	<RevCode>
Date:	Wednesday, January 18, 2011	Sheet 5 of 12

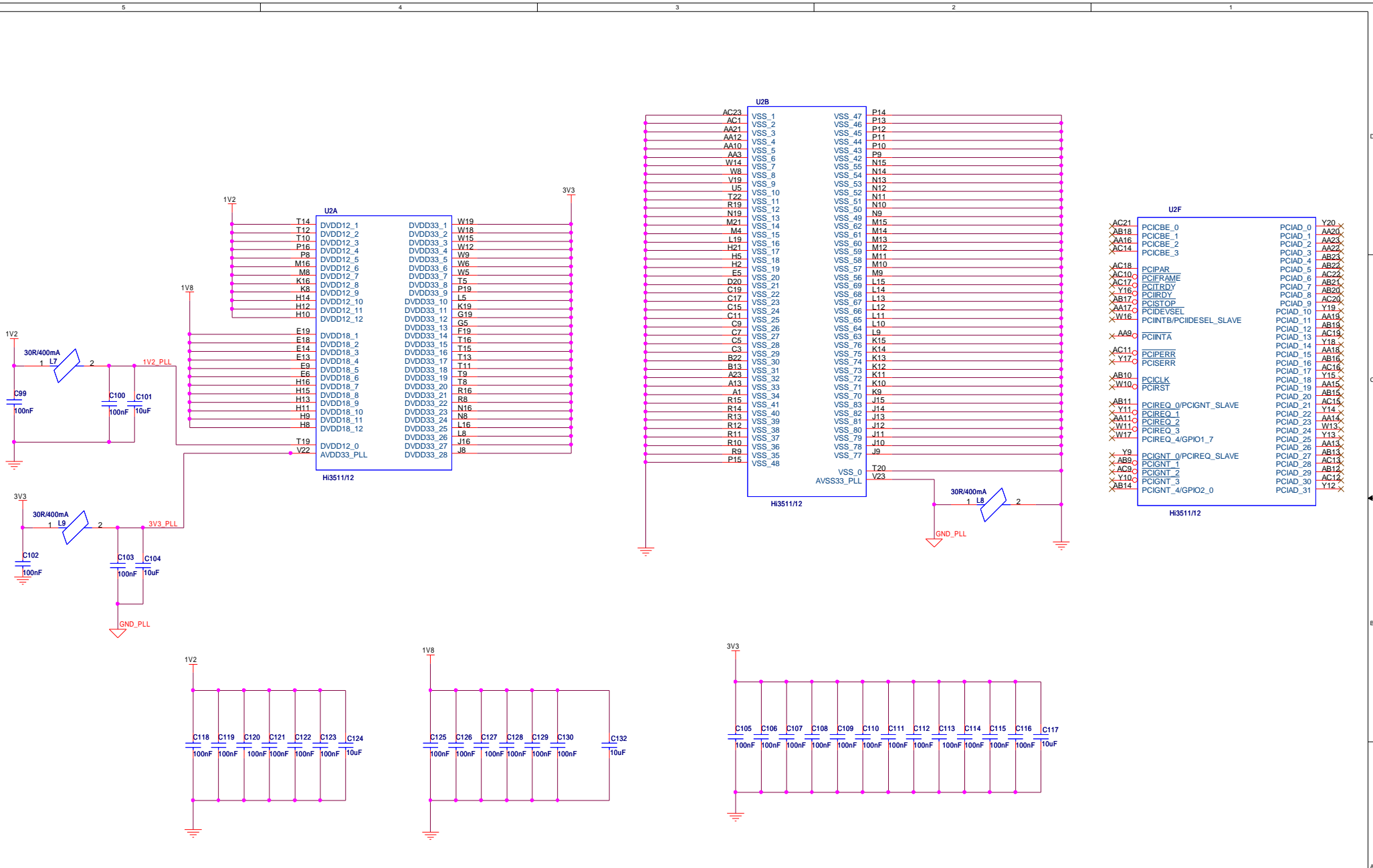

Title		
<Title>		
Size	Document Number	Rev
A3	<Doc>	<RevCode>
Date:	Tuesday, March 17, 2009	Sheet 6 of 12

FOR DIFFERENTIAL AND COMMON MODE PROTECTION

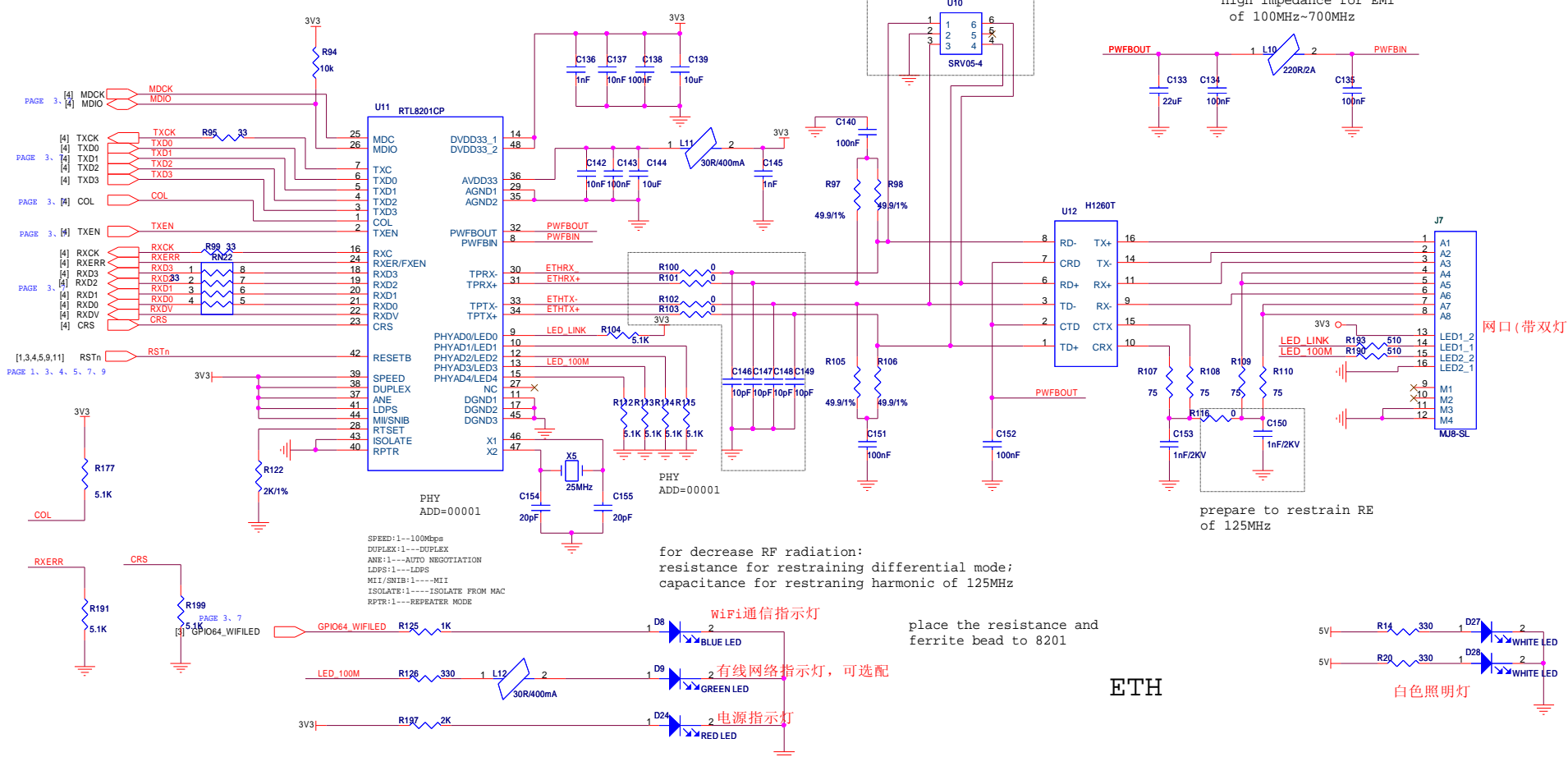

high impedance for EMI of 100MHz-700MHz

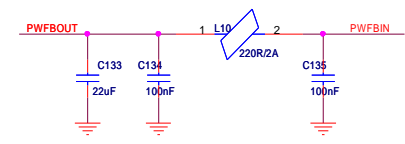

网口 (带双灯)

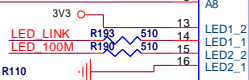

prepare to restrain RE of 125MHz

for decrease RF radiation:
resistance for restraining differential mode;
capacitance for restraining harmonic of 125MHz

place the resistance and ferrite bead to 8201

ETH

白色照明灯

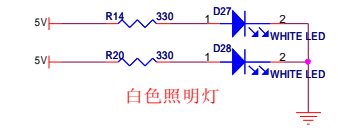

PHY ADD=00001
SPEED=1-100Mbps
DUPLEX:1---DUPLEX
ANE:1---AUTO NEGOTIATION
LDPS:1---LDPS
MII/SNIB:1---MII
ISOLATE:1---ISOLATE FROM MAC
RPTR:1---REPEATER MODE

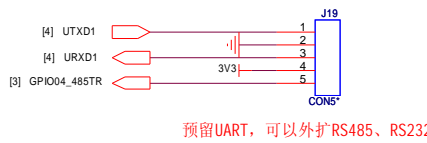
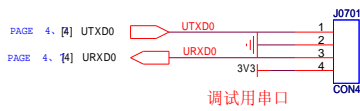
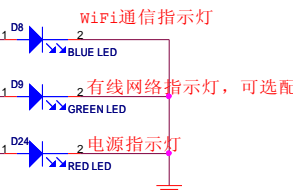

Title		<Title>
Size	Document Number	Rev
A3	<Doc>	<RevCode>
Date:	Monday, January 24, 2011	Sheet 7 of 12

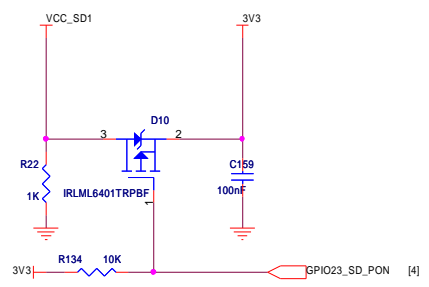
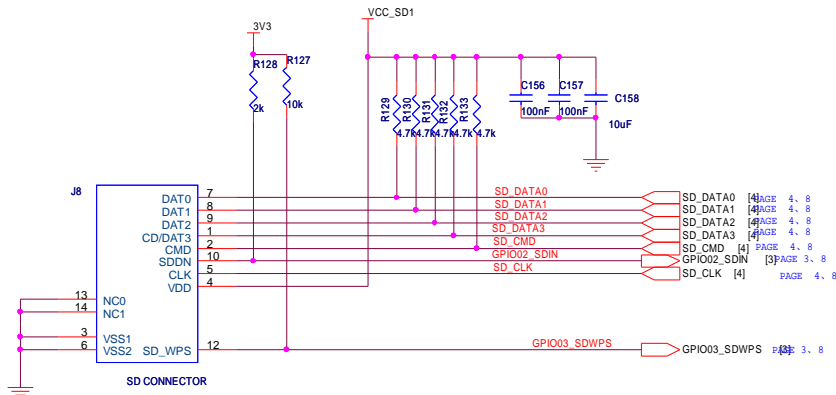

SD CARD

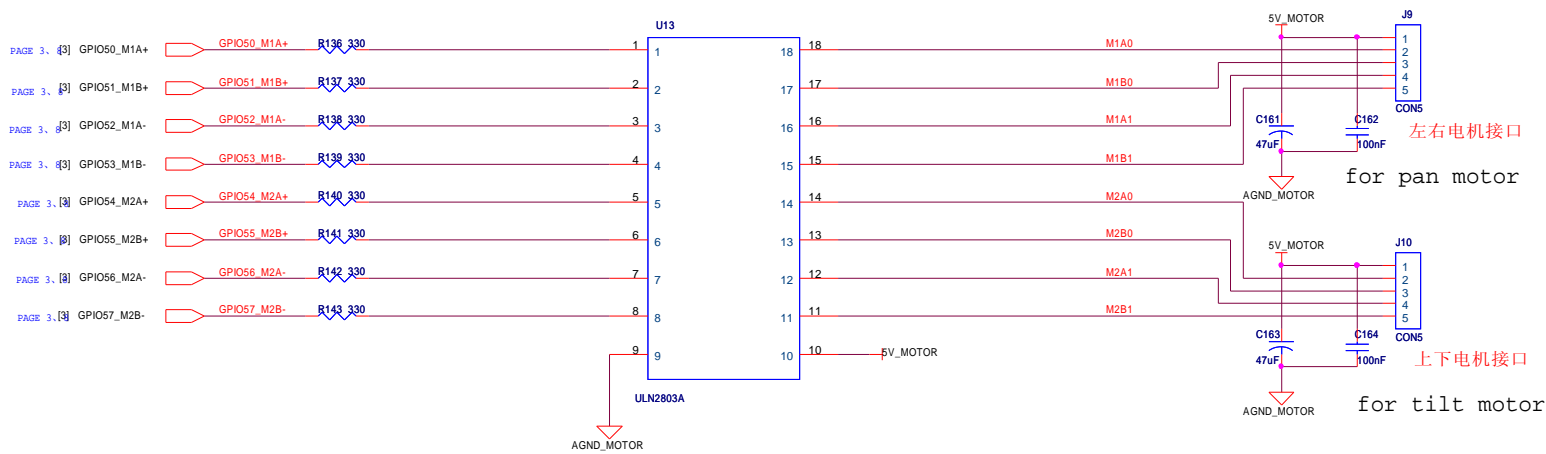

左右电机接口

for pan motor

上下电机接口

for tilt motor

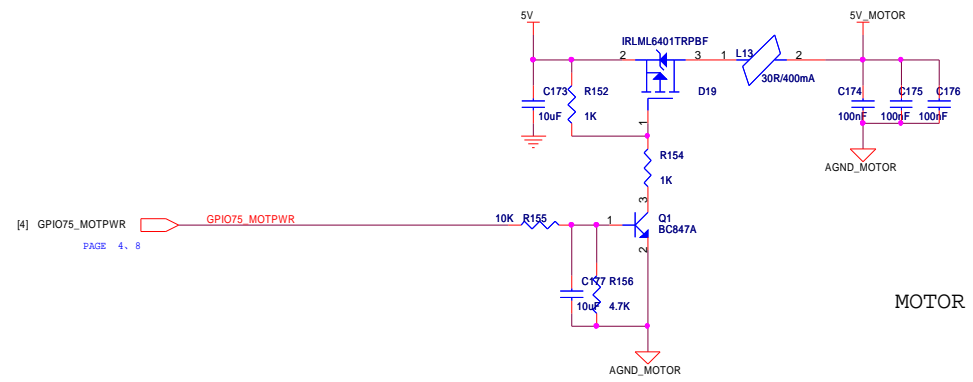

MOTOR

Title		
<Title>		
Size	Document Number	Rev
A3	<Doc>	<RevCode>
Date:	Wednesday, January 19, 2011	Sheet 8 of 12

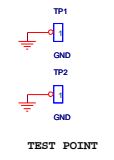
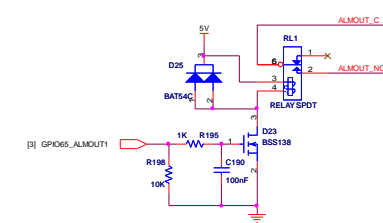
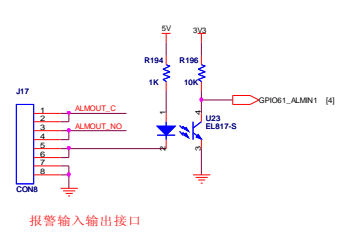
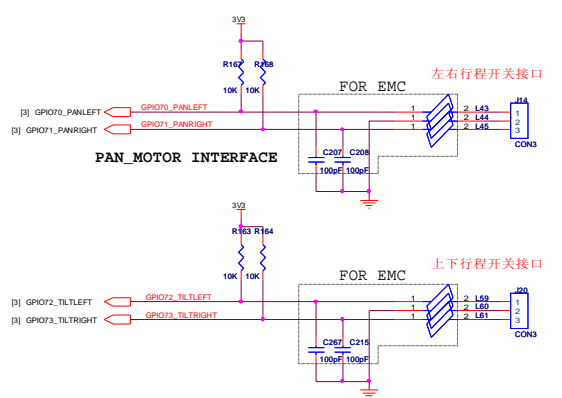
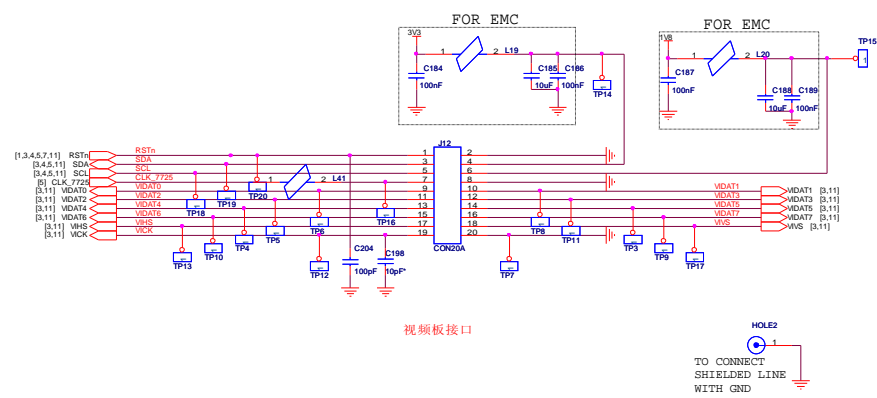
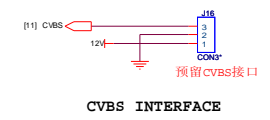
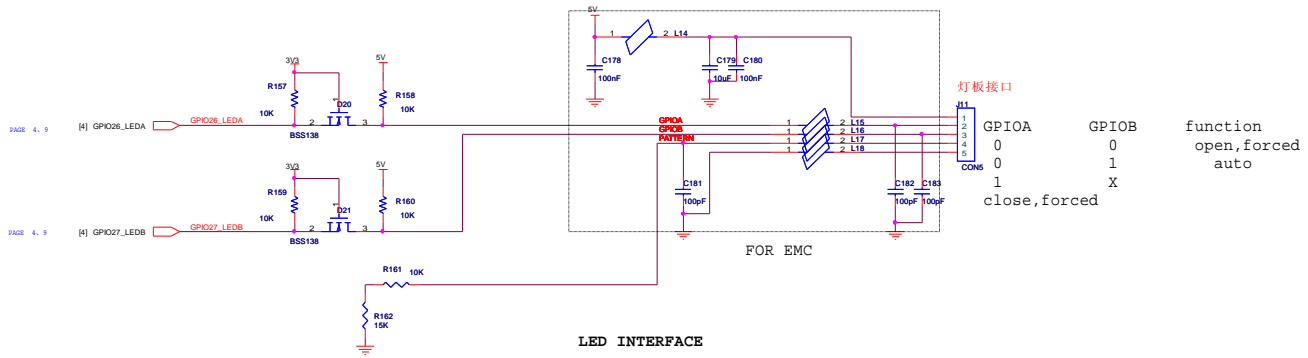

File	<Title>	Rev
Sheet	Document Number	<Doc>
Date:	Monday, March 14, 2011	Sheet 9 of 12

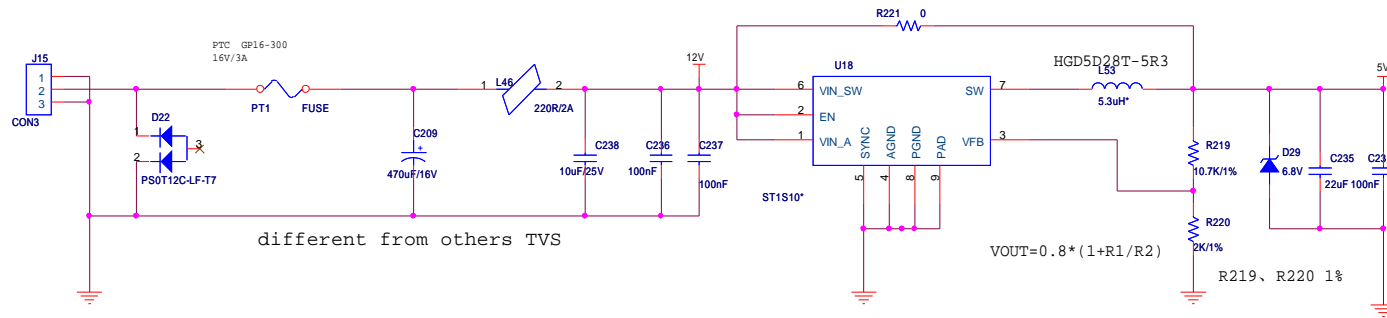

different from others TVS

$$V_{OUT} = 0.8 * (1 + R1/R2)$$

12V----5V

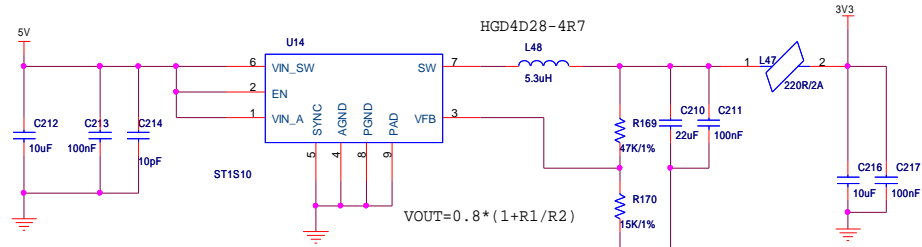

$$V_{OUT} = 0.8 * (1 + R1/R2)$$

5V----3.3V

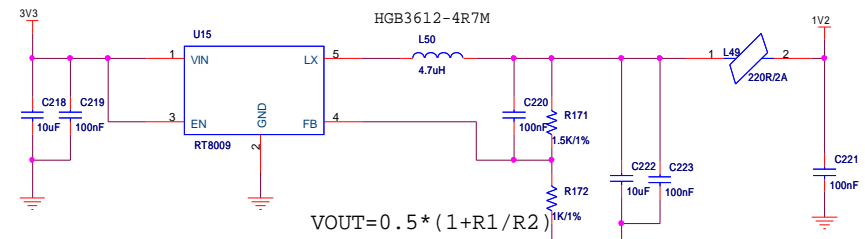

$$V_{OUT} = 0.5 * (1 + R1/R2)$$

3.3V----1.25V
Hi3511 core

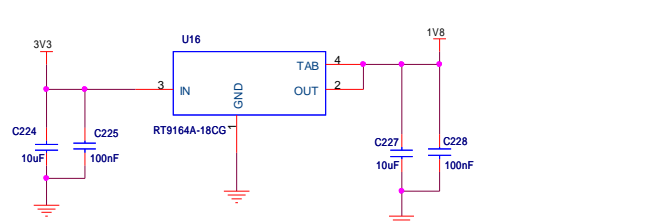

fov7720 & TLV320AIC32 core and DDR2

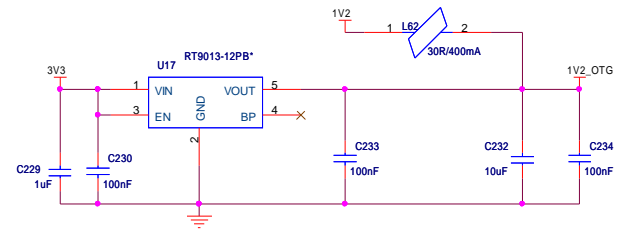

Title		
<Title>		
Size	Document Number	Rev
A3	<Doc>	<RevCode>
Date:	Friday, April 22, 2011	Sheet 10 of 12

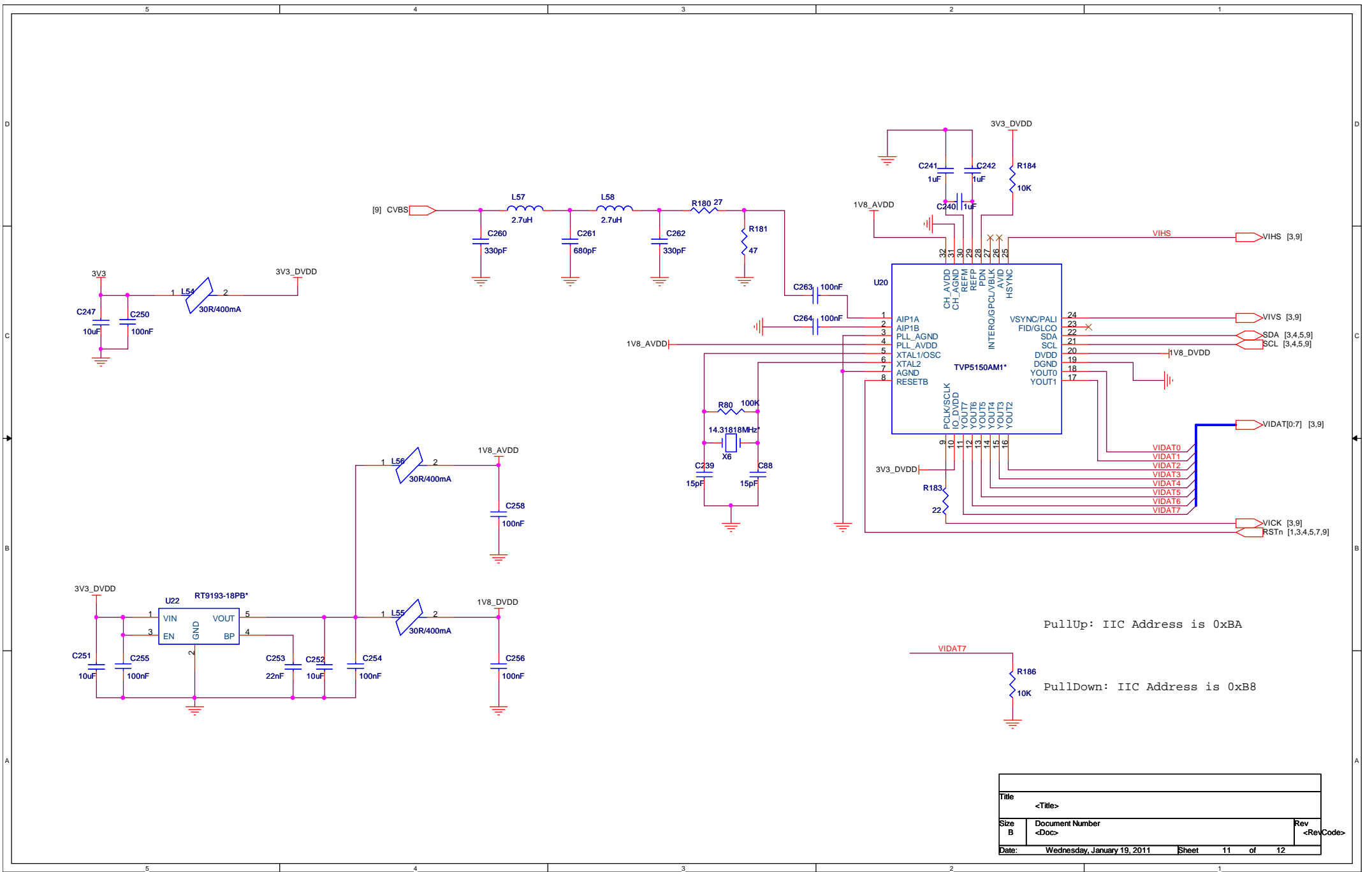

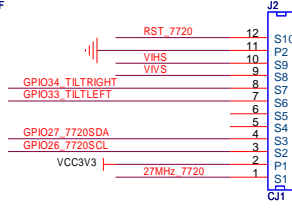
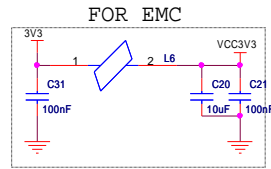
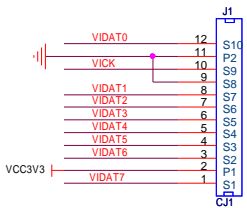
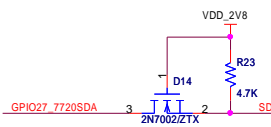
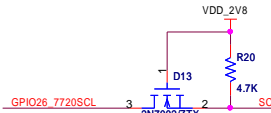
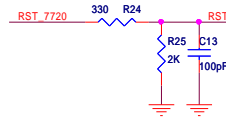
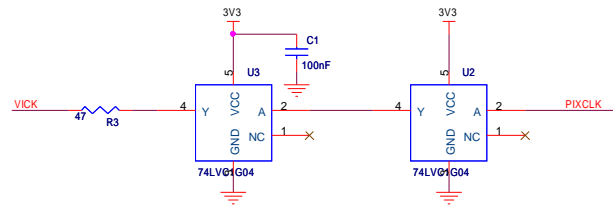
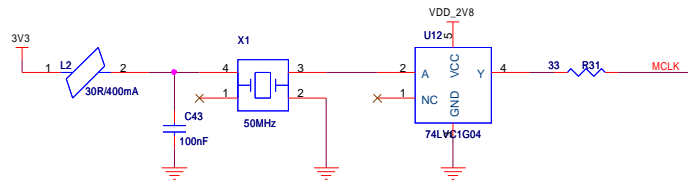
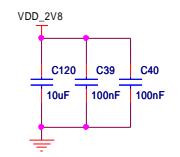
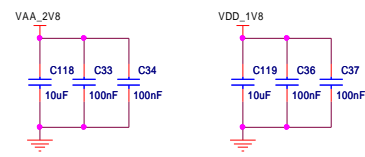
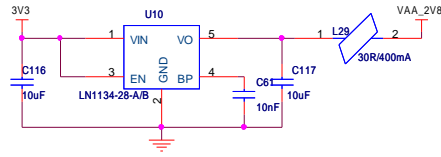
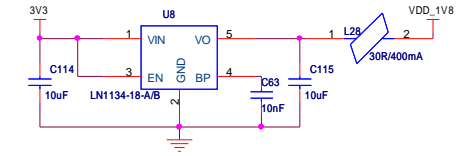
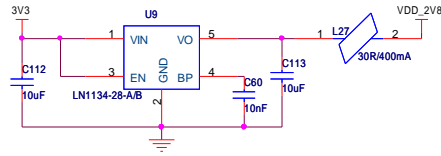
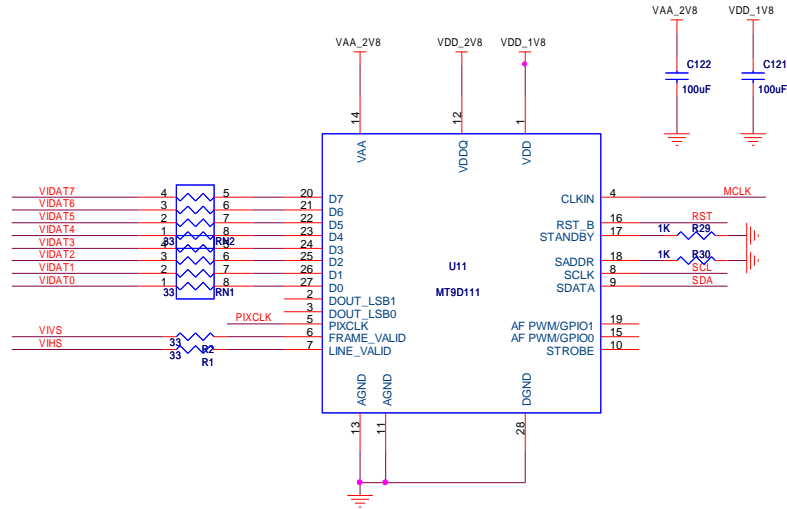

INTERFACE

Title		<Title>
Size	Document Number	Rev
A3	<Doc>	<RevCode>
Date:	Wednesday, March 16, 2011	Sheet 1 of 1

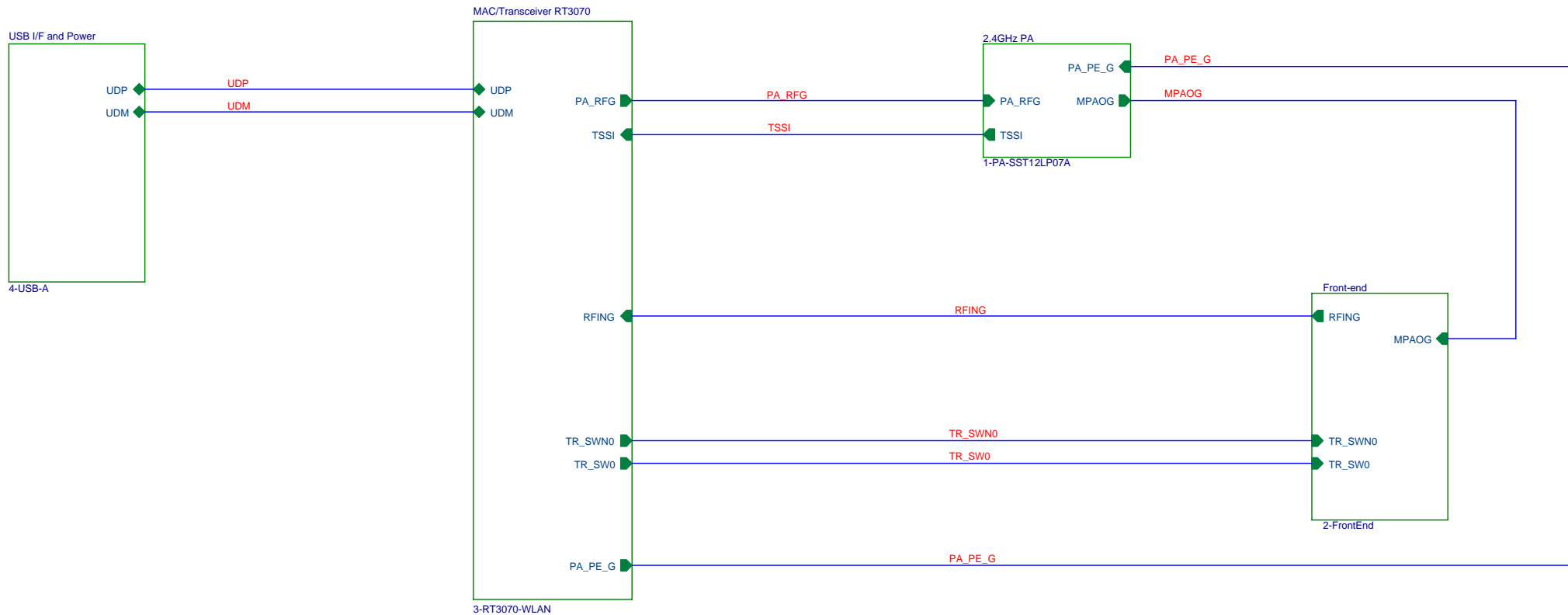

Filename:
PEN-RT3070-QFN-V33ST-A-081013.DSN

	RALINK TECHNOLOGY, CORP.	
	Title 2.4G USB Card - RT3070	
Size B	Document Number PEN-RT3070-V33ST-A.SCH	Rev 3.3
Date: Tuesday, November 25, 2008	Sheet 1 of 6	

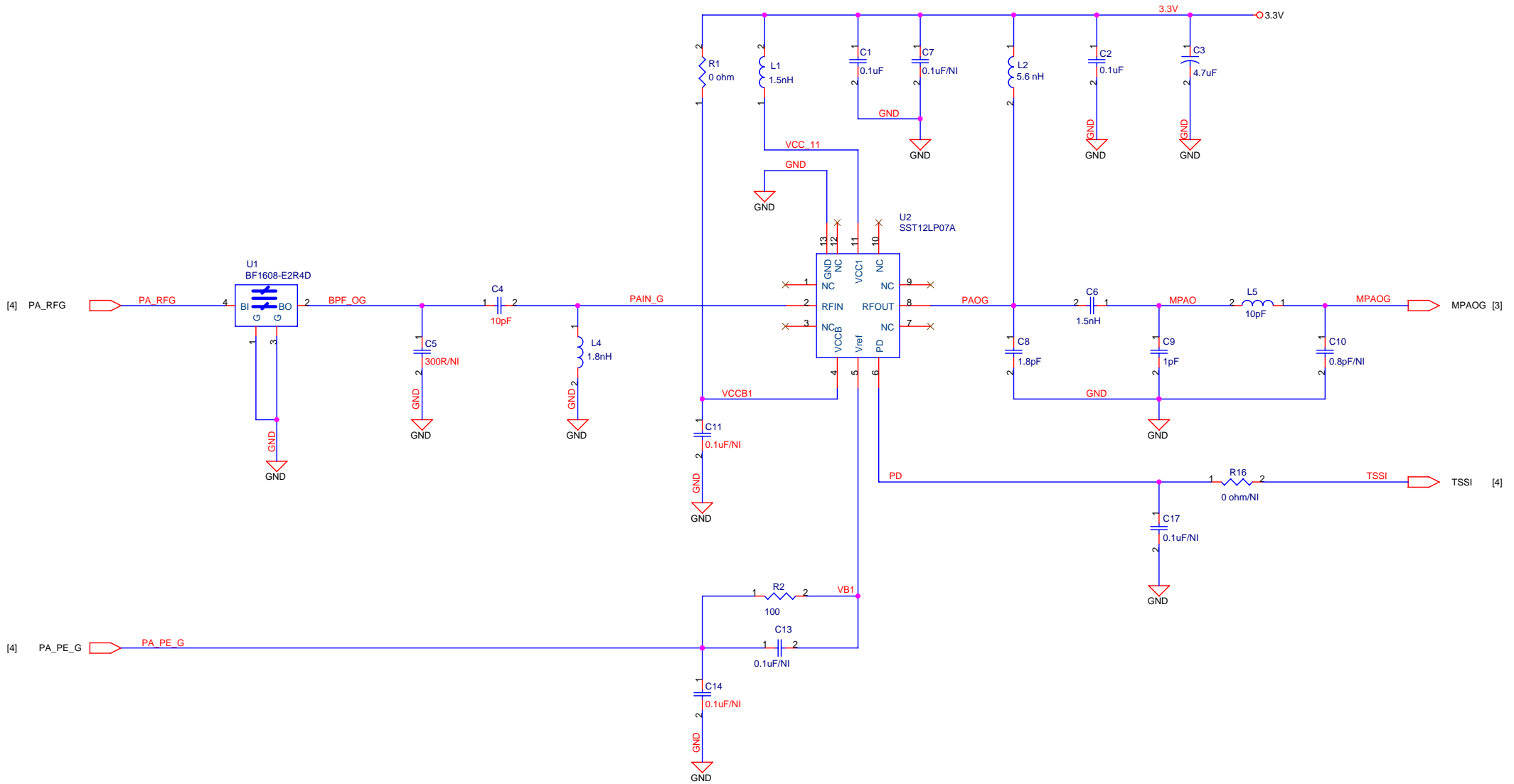

RALINK TECHNOLOGY, CORP.

Title		2.4GHz PA
Size	Document Number	1-PA-SST12LP07A.SCH
Date:	Wednesday, October 15, 2008	Sheet 2 of 6
Rev		3.3

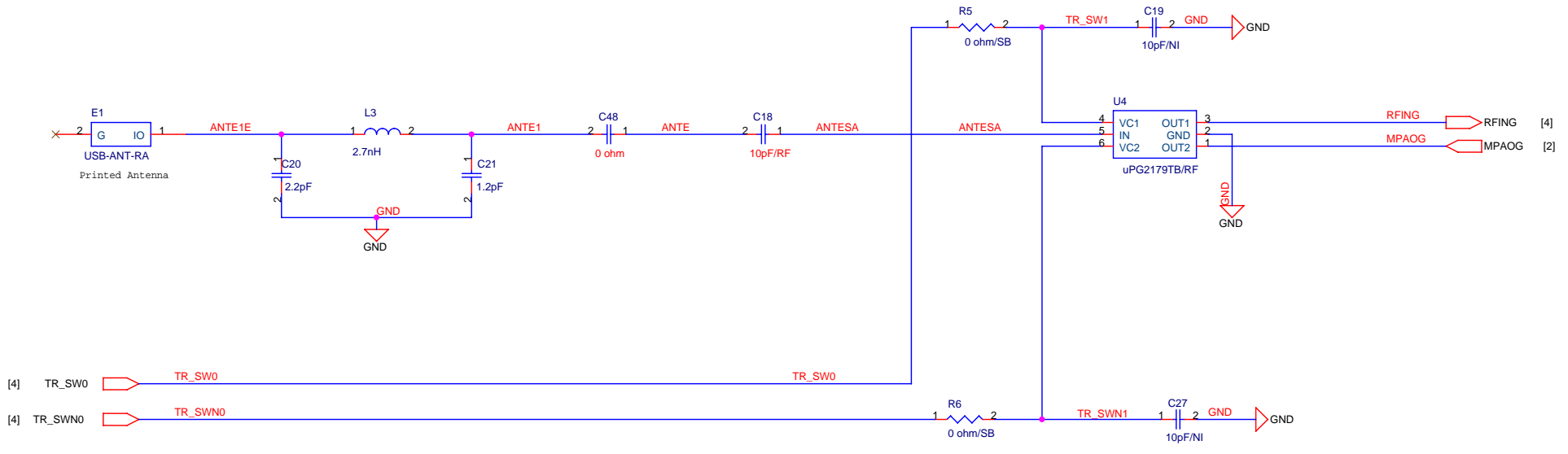

		RALINK TECHNOLOGY, CORP.	
		Title Front-End	
Size B	Document Number 2-FrontEnd.SCH		Rev 3.3
Date:	Wednesday, October 15, 2008	Sheet	3 of 6

Place RT1 close to Power Amp.

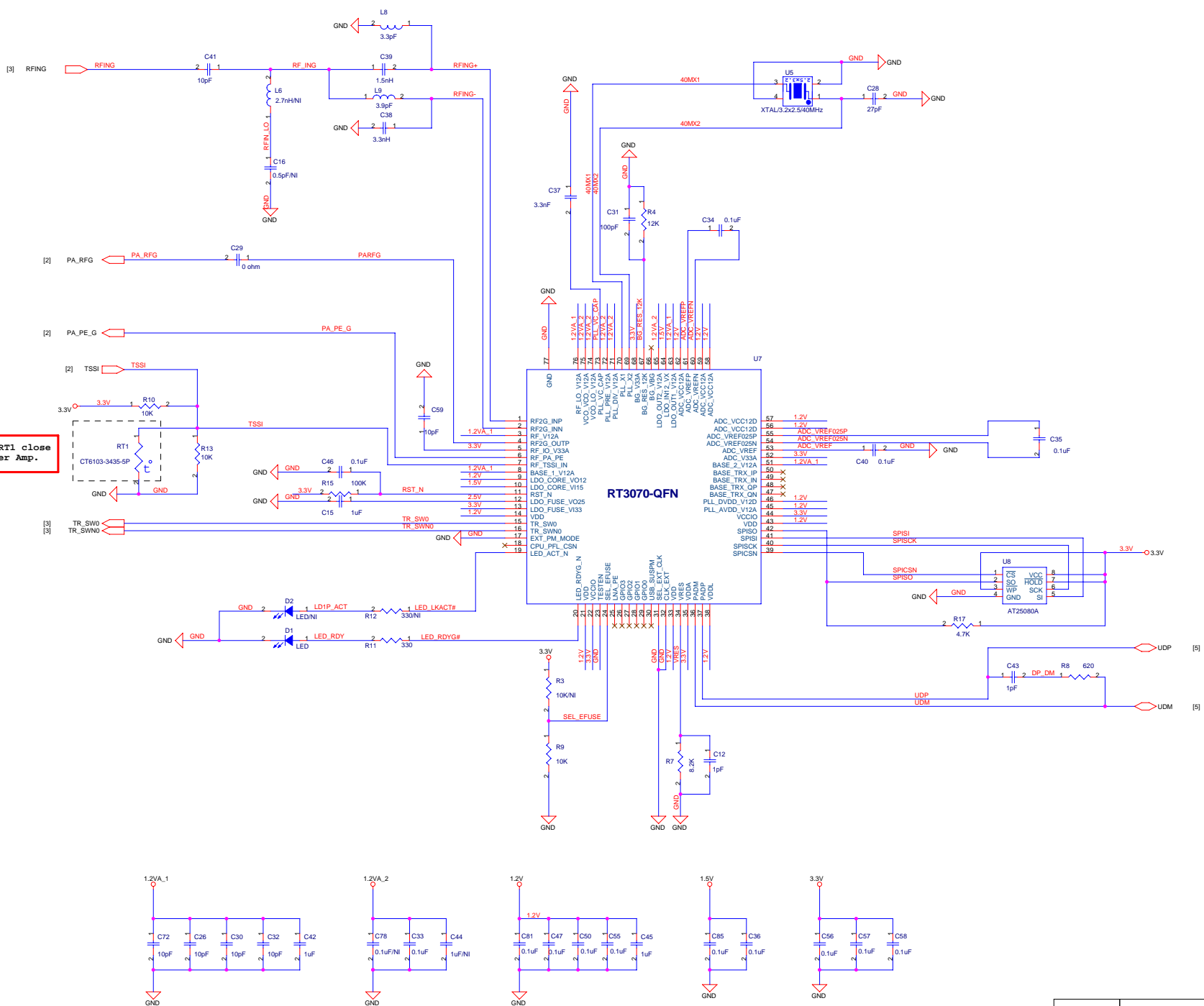

		RALINK TECHNOLOGY, CORP.	
		File	RT3070-WLAN
Size	C	Document Number	3-RT3070-WLAN.SCH
Date	Wednesday, October 15, 2008	Sheet	4 of 6
Rev	3.3		

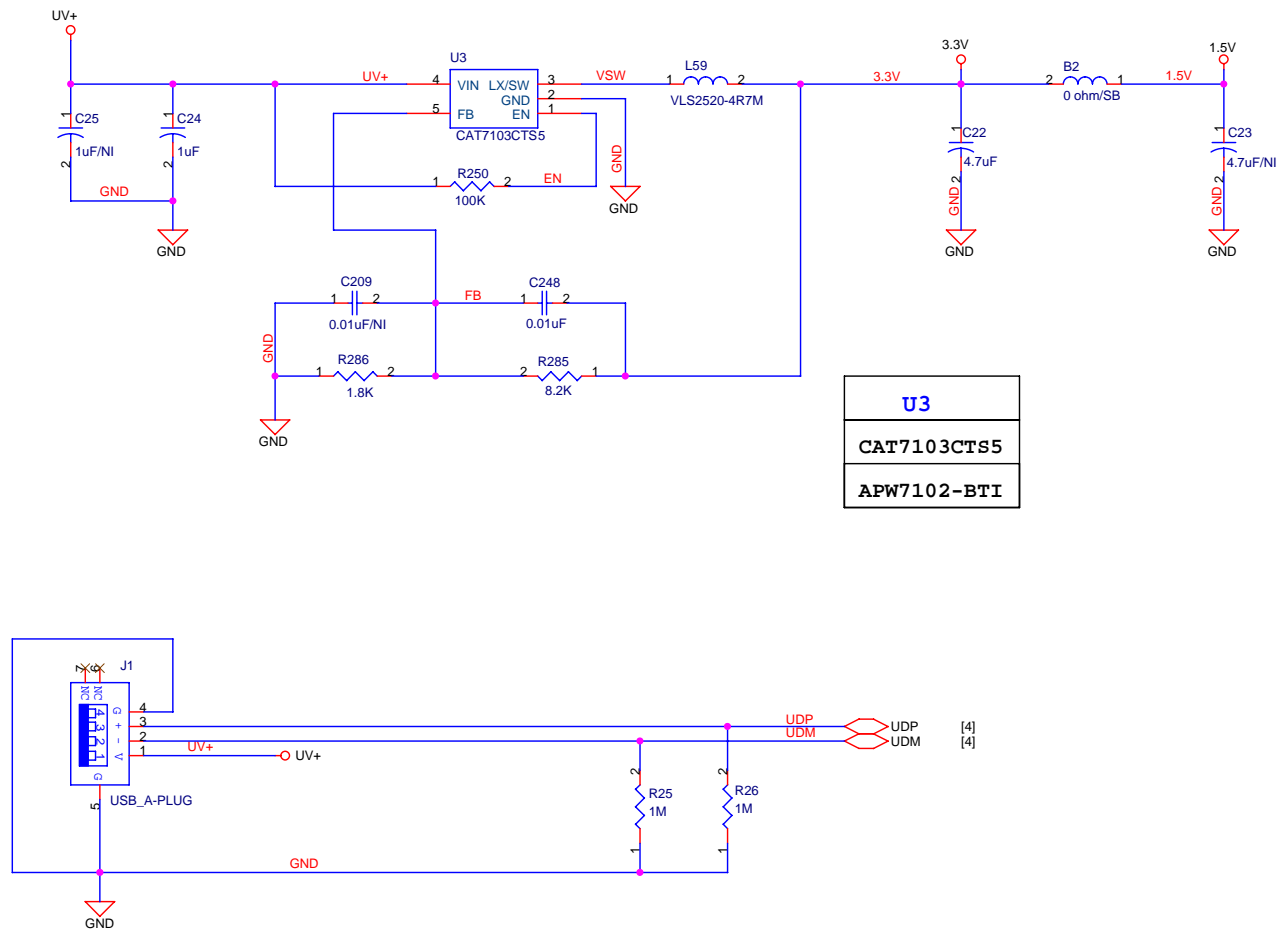

U3
CAT7103CTS5
APW7102-BTI

		RALINK TECHNOLOGY, CORP.	
		Title PEN USB Interface and Power	
Size B	Document Number 4-USB-A.SCH	Rev 3.3	
Date: Tuesday, November 25, 2008	Sheet 5	of 6	