

HI3511_IPCAMERA_VA

Title			<Title>
Size	Document Number	Rev	
A3	<Doc>	<RevCode>	
Date:	Tuesday, February 03, 2009	Sheet	12 of 12

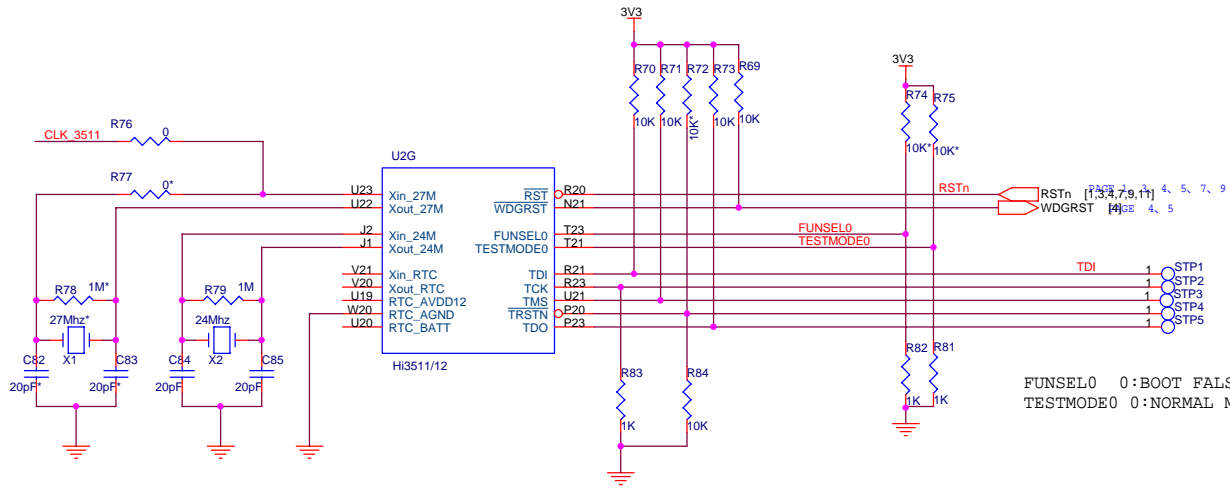

Hi3511 CLK AND JTAG

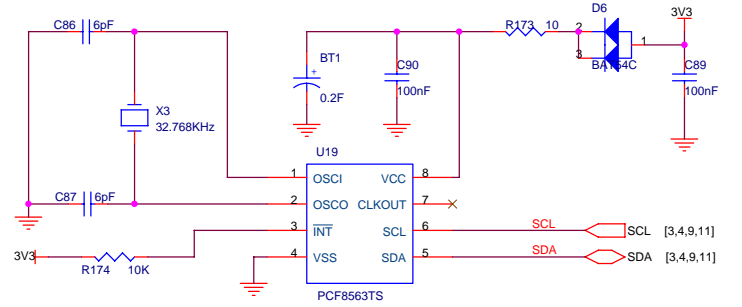

RTC

FUNSEL0 0:BOOT FALSH 1:BOOT DDR
 TESTMODE0 0:NORMAL MODE 1:TEST MODE

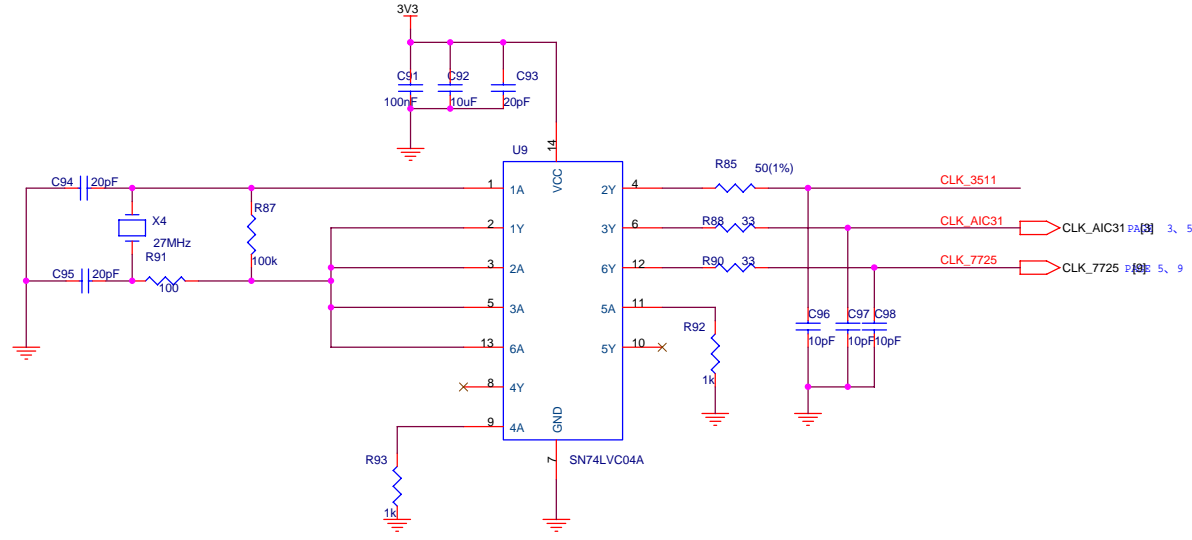

CLOCK

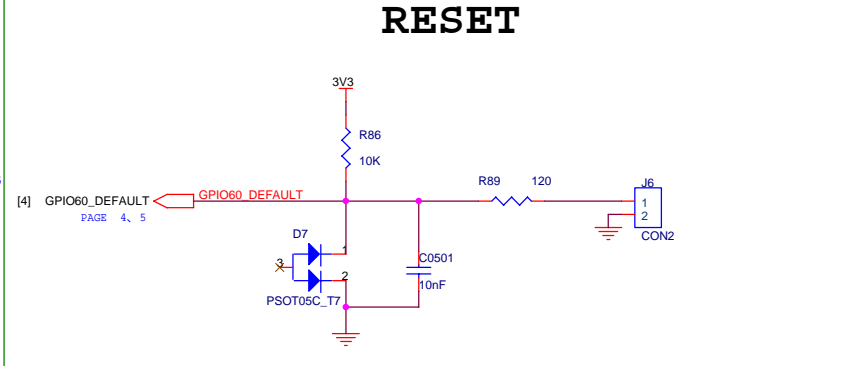

RESET

DEFAULT

Title		
<Title>		
Size	Document Number	Rev
A3	<Doc>	<RevCode>
Date:	Tuesday, March 17, 2009	Sheet 5 of 12

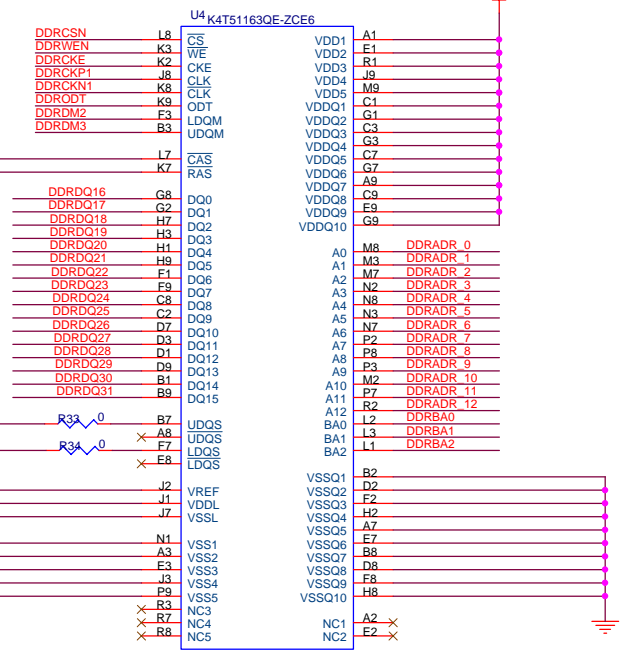
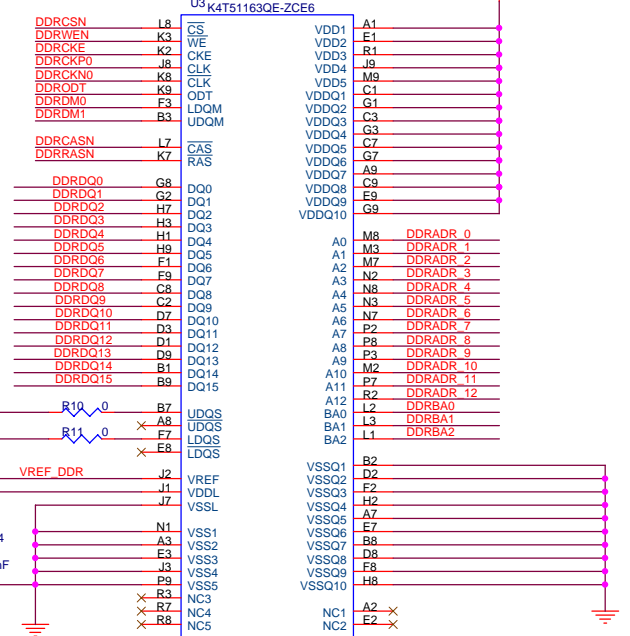
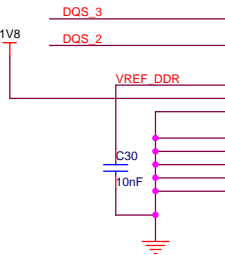
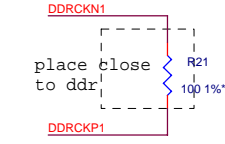
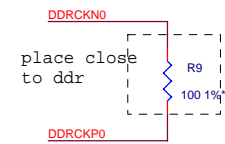
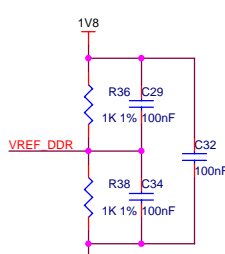
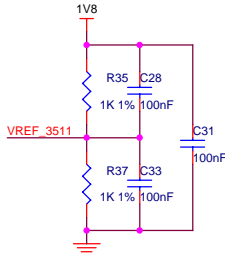
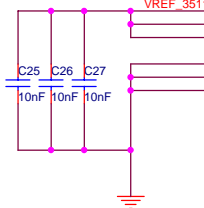
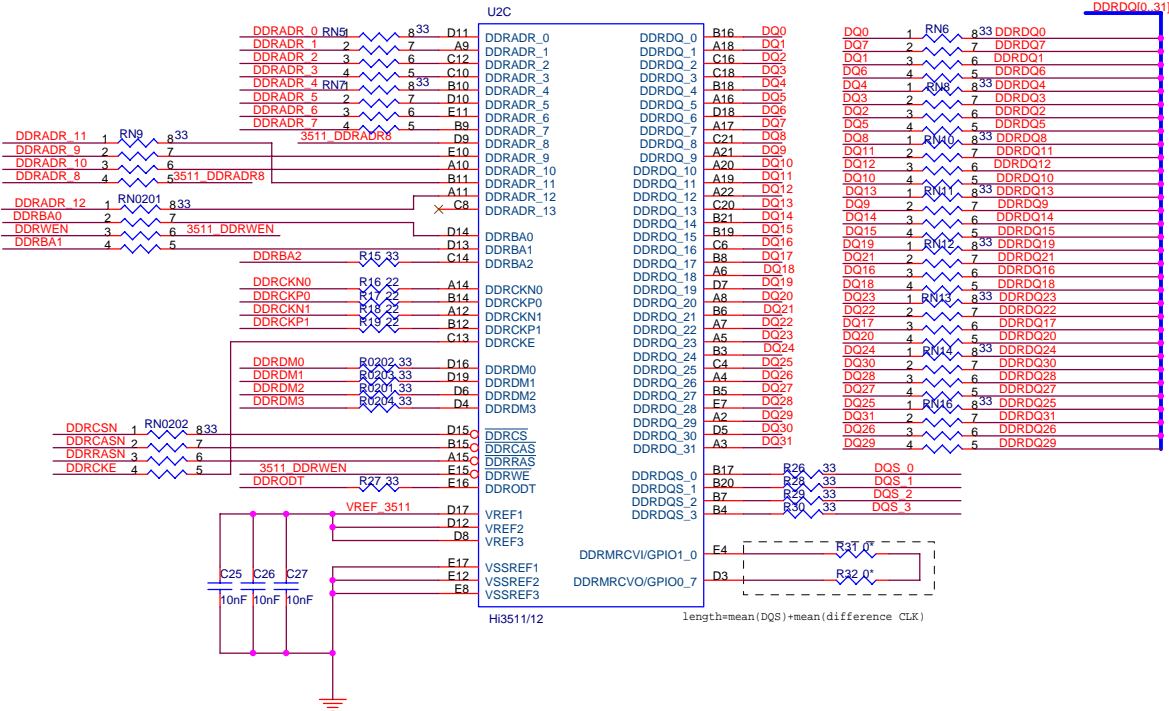
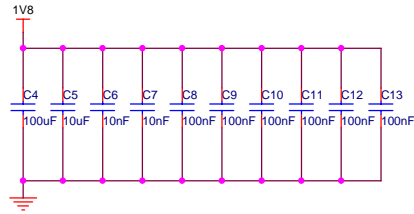
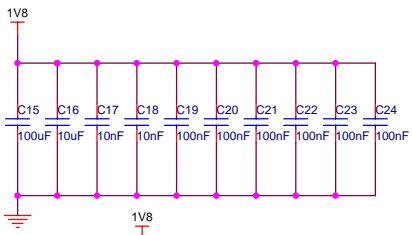

BA2 for 1Gb
16bits only
for Hi3512

Title	<Title>		Rev	<RevCode>
Size	A3	Document Number	<Doc>	
Date:	Tuesday, March 17, 2009	Sheet	2	of 12

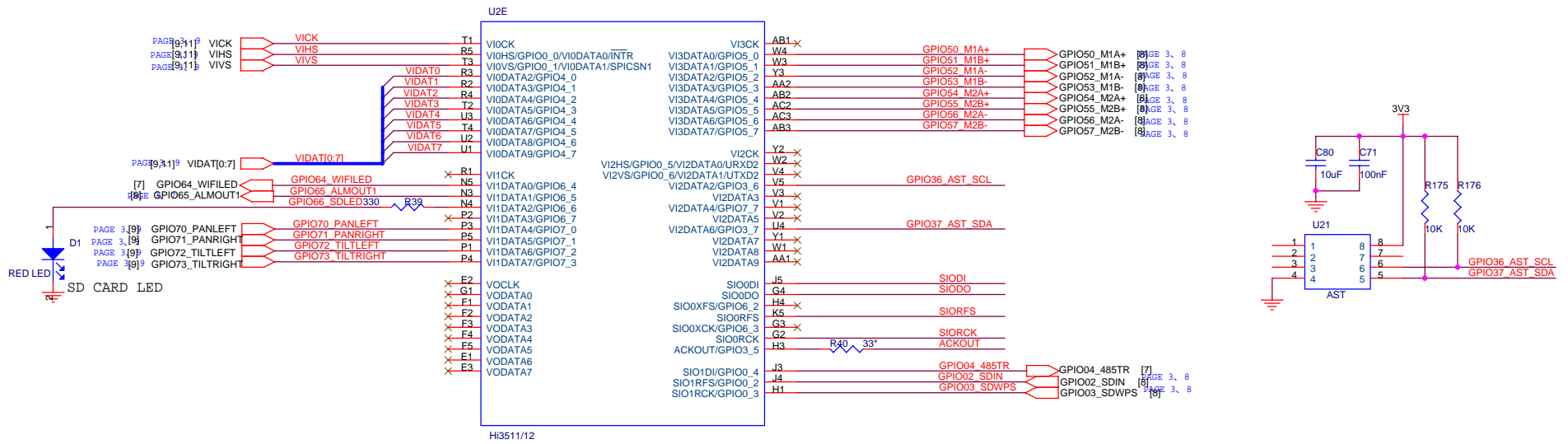

Hi3511 VIDEO AND AUDIO

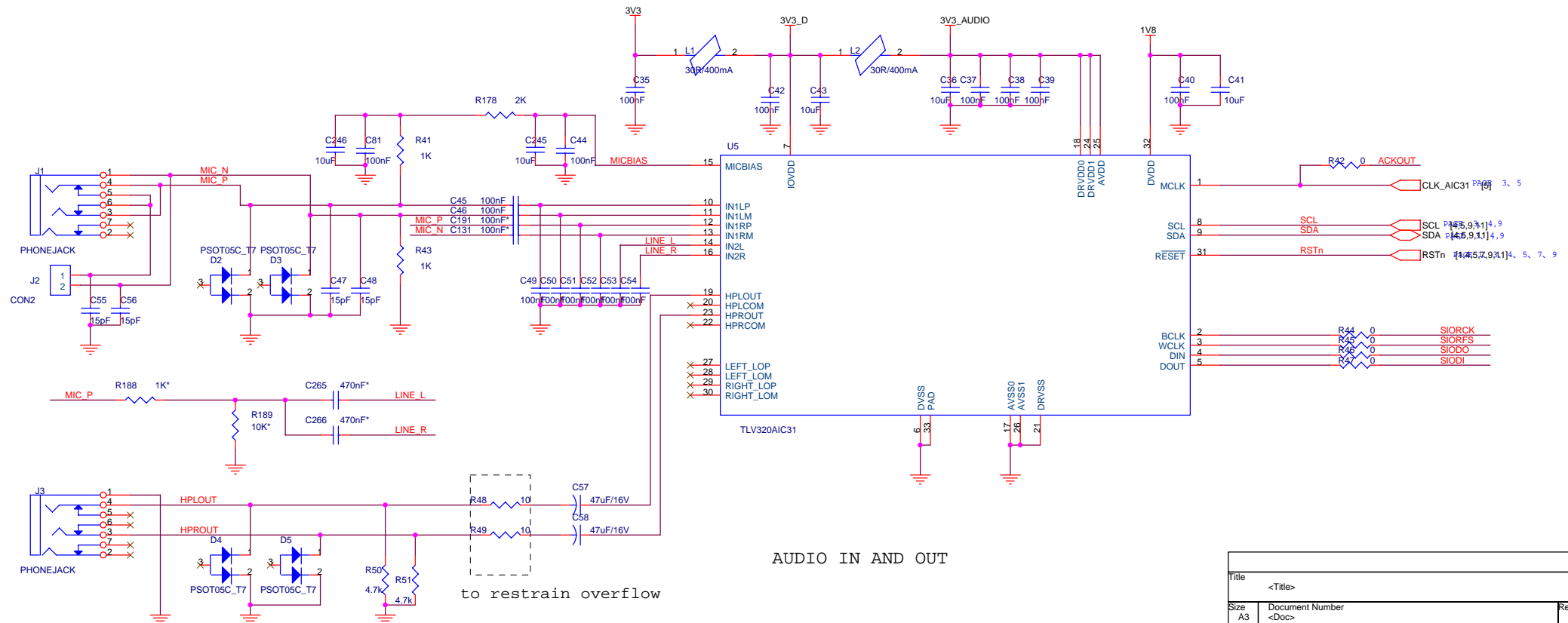

AUDIO IN AND OUT

Title			<Title>
Size	Document Number	Rev	
A3	<Doc>	<RevCode>	
Date:	Tuesday, March 17, 2009	Sheet	3 of 12

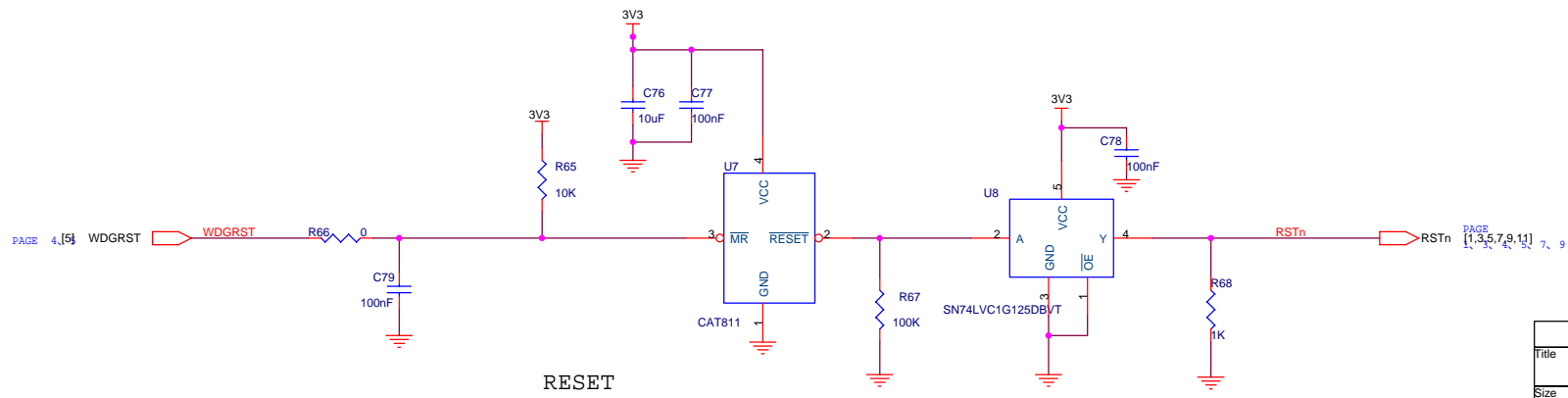
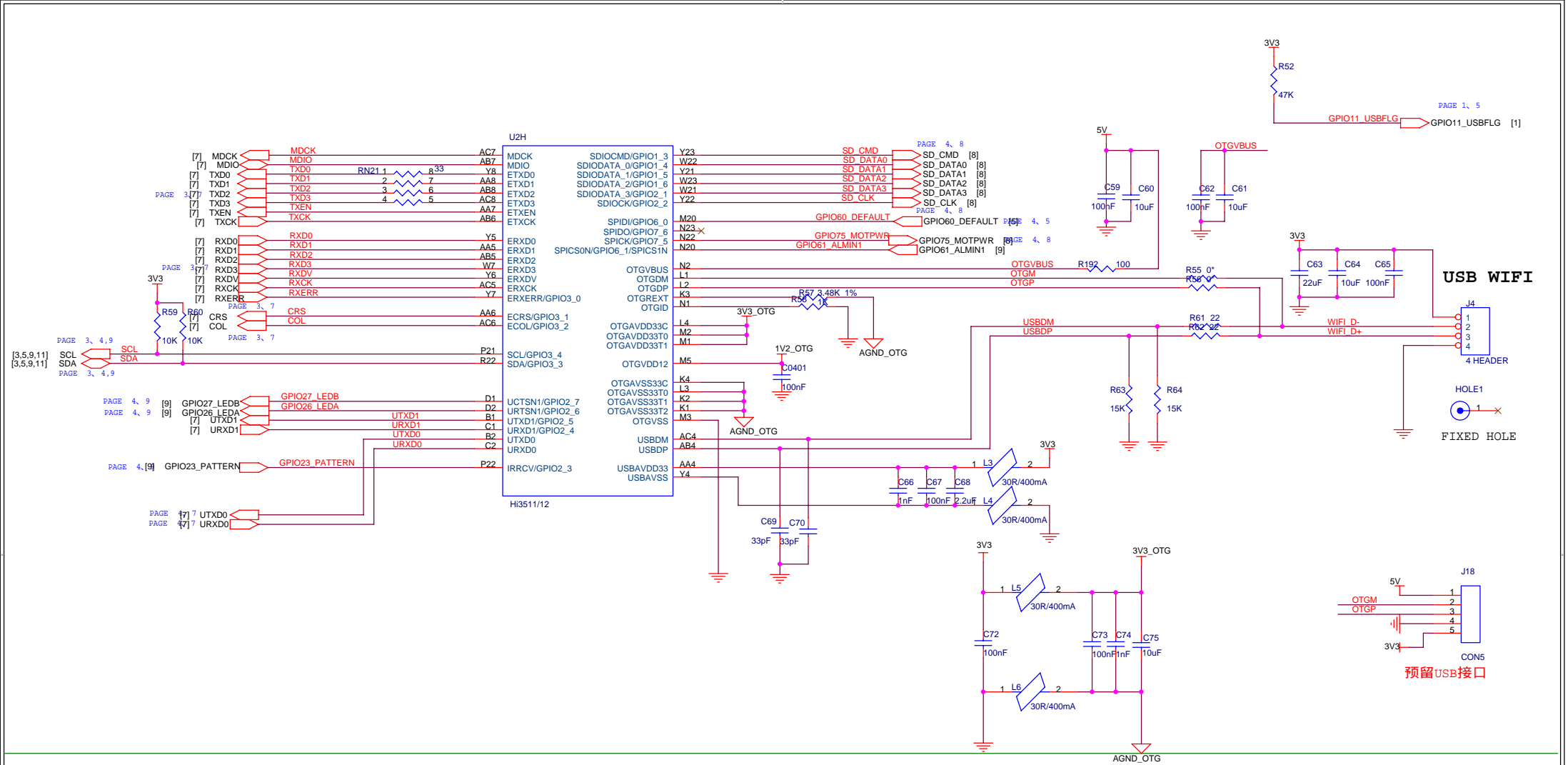

Title		<Title>
Size	A3	Document Number
Date:	Tuesday, March 17, 2009	Sheet 4 of 12
Rev	<Doc>	<Rev Code>

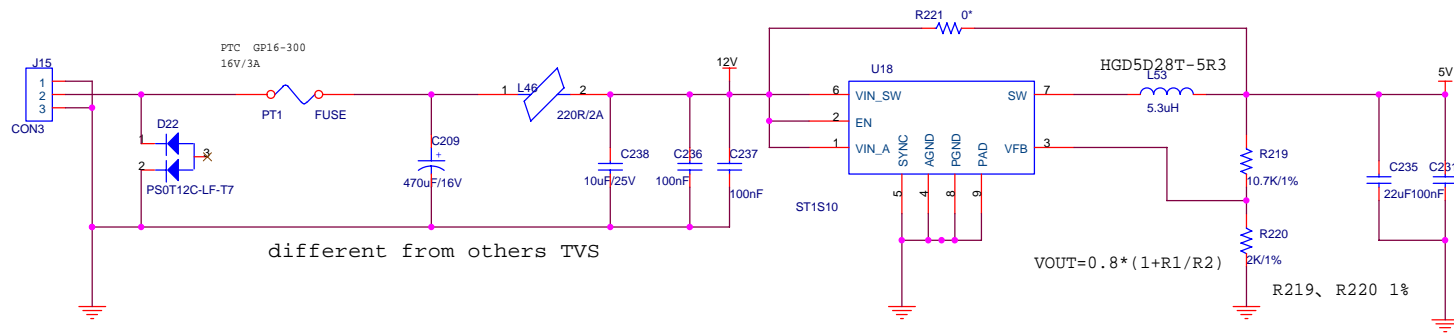

12V----5V

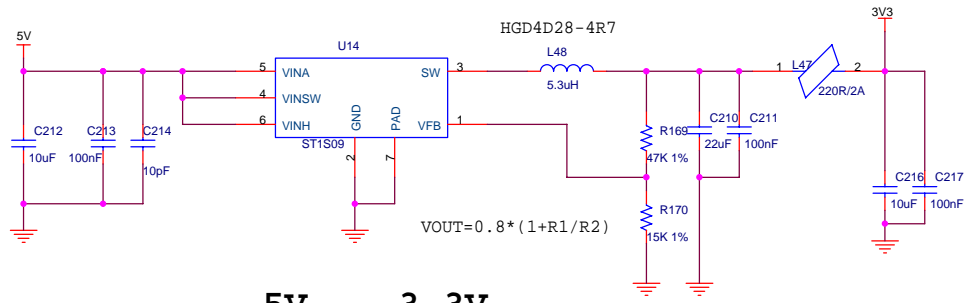

5V----3.3V

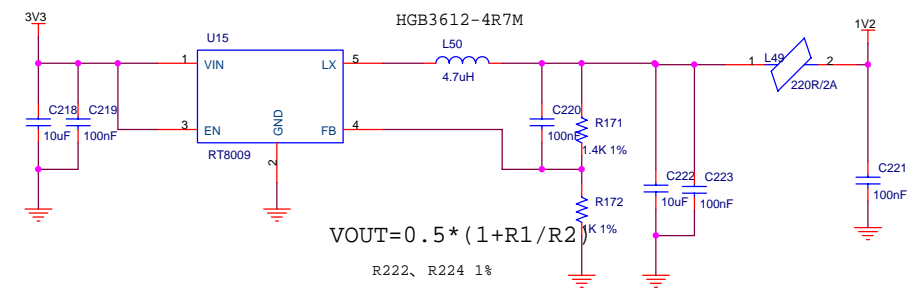

**3.3V----1.2V
Hi3511 core**

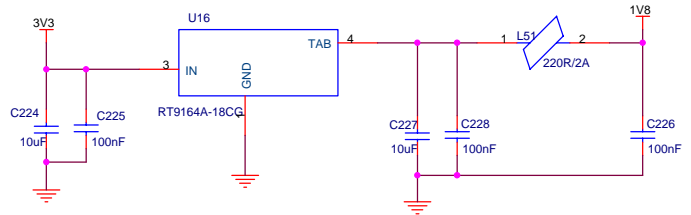

FOV7720 & TLV320AIC32 core and DDR2

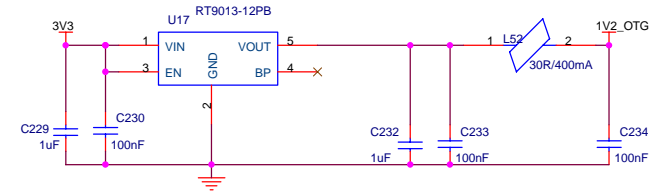

Title		
<Title>		
Size	Document Number	Rev
A3	<Doc>	<RevCode>
Date:	Wednesday, March 18, 2009	Sheet 10 of 12

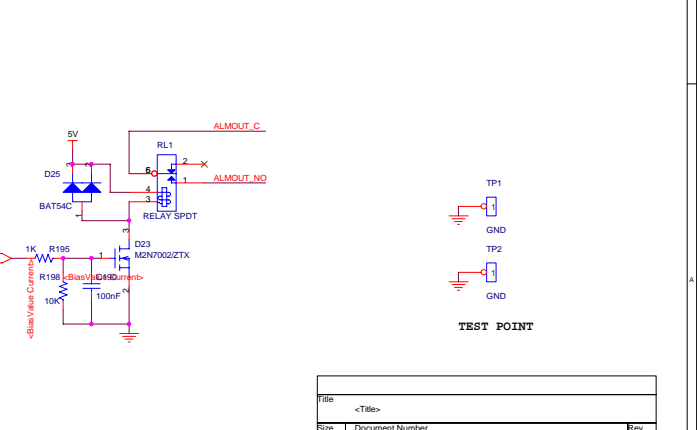
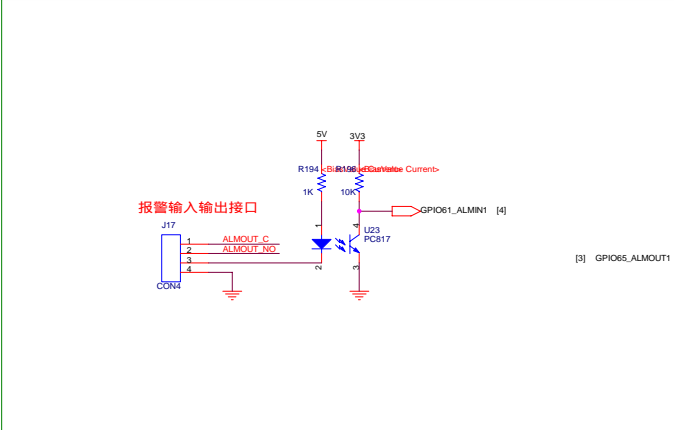
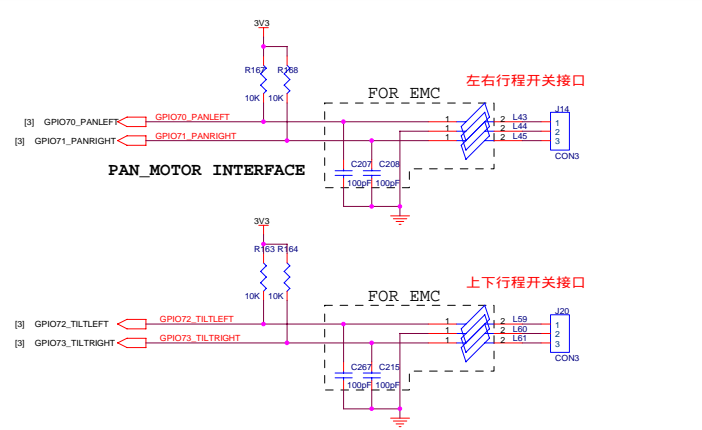
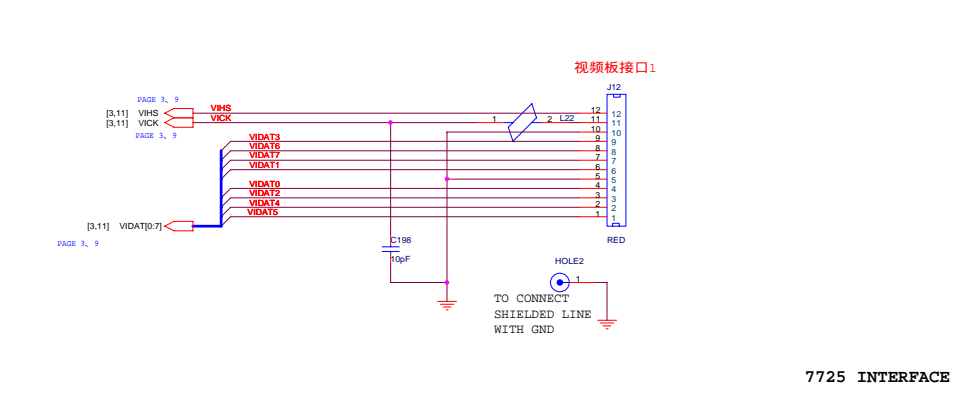
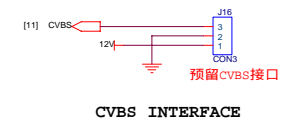
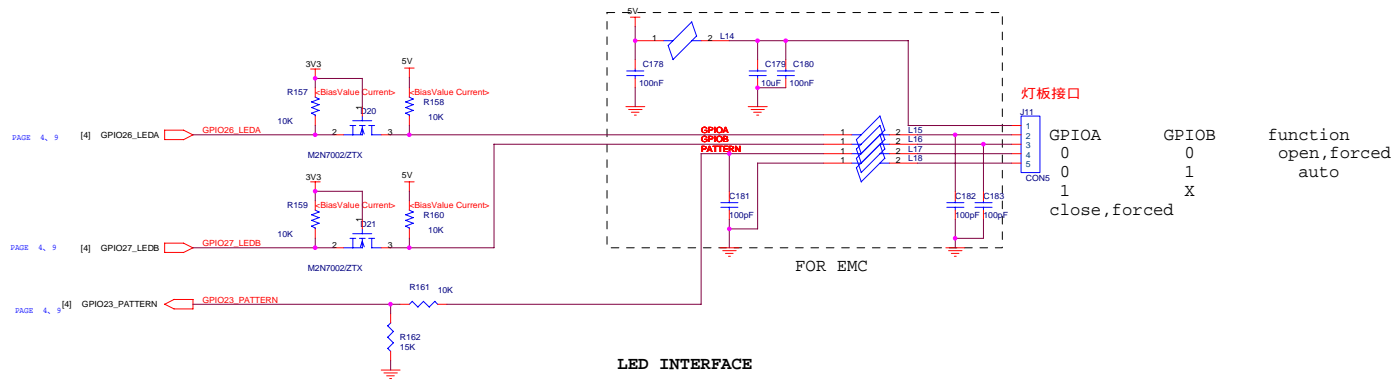

file	<Title>	Rev
Size	Document Number	<RevCode>
A2	<Doc>	
Date:	Tuesday, March 17, 2009	Sheet 9 of 12

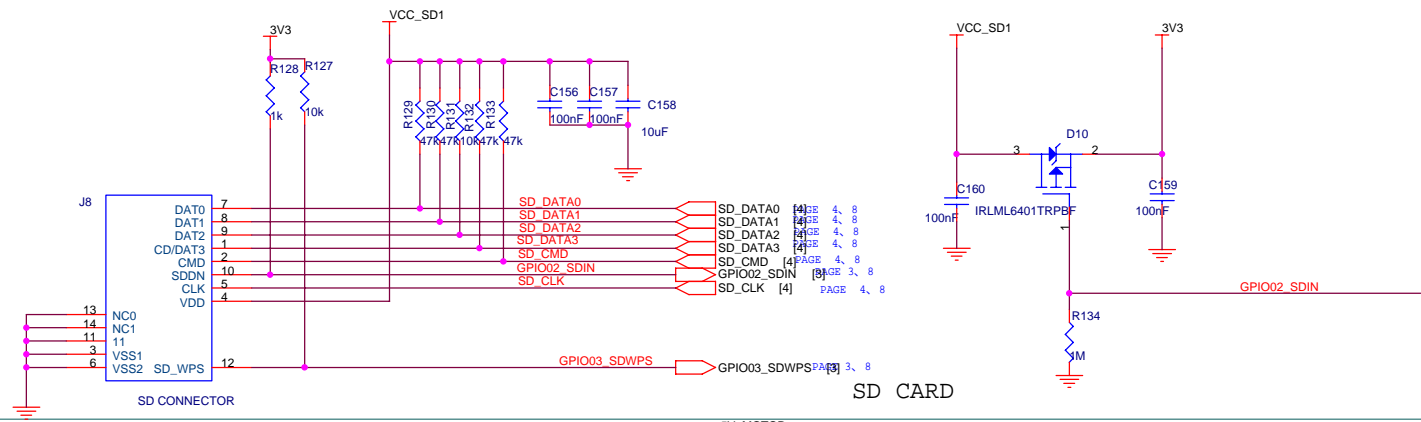

SD CARD

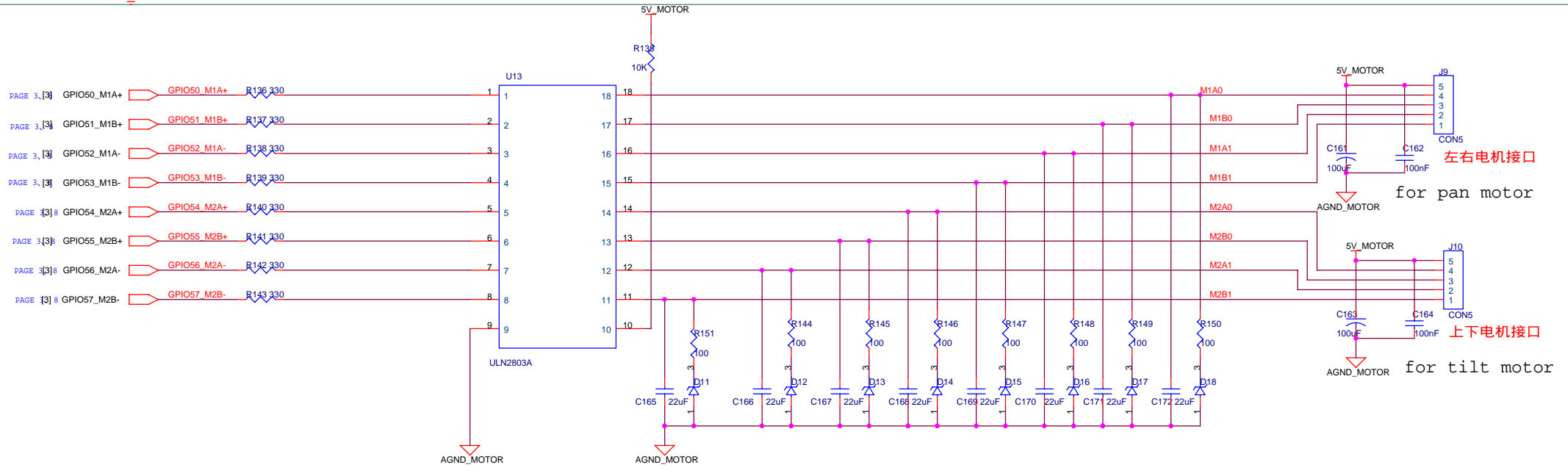

MOTOR

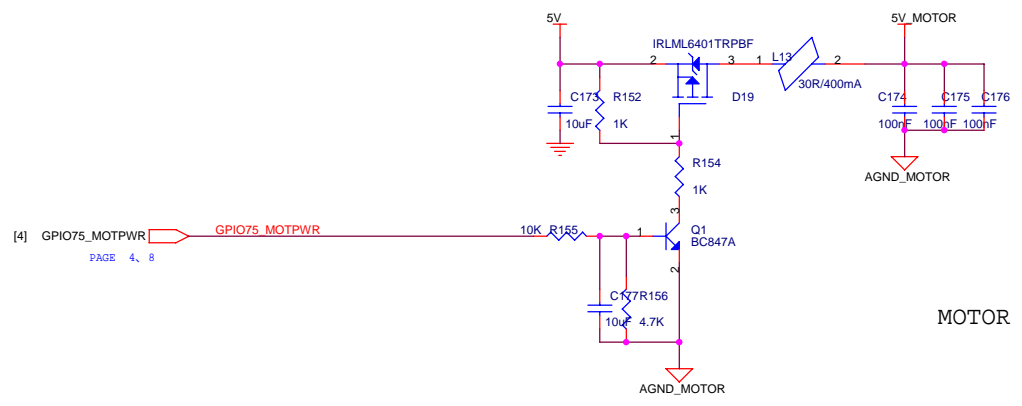

Title		
<Title>		
Size	Document Number	Rev
A3	<Doc>	<Rev Code>
Date:	Tuesday, March 17, 2009	Sheet 8 of 12

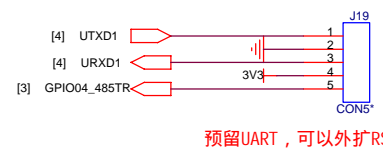
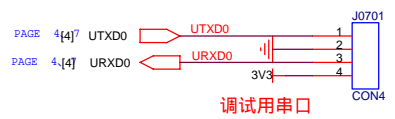
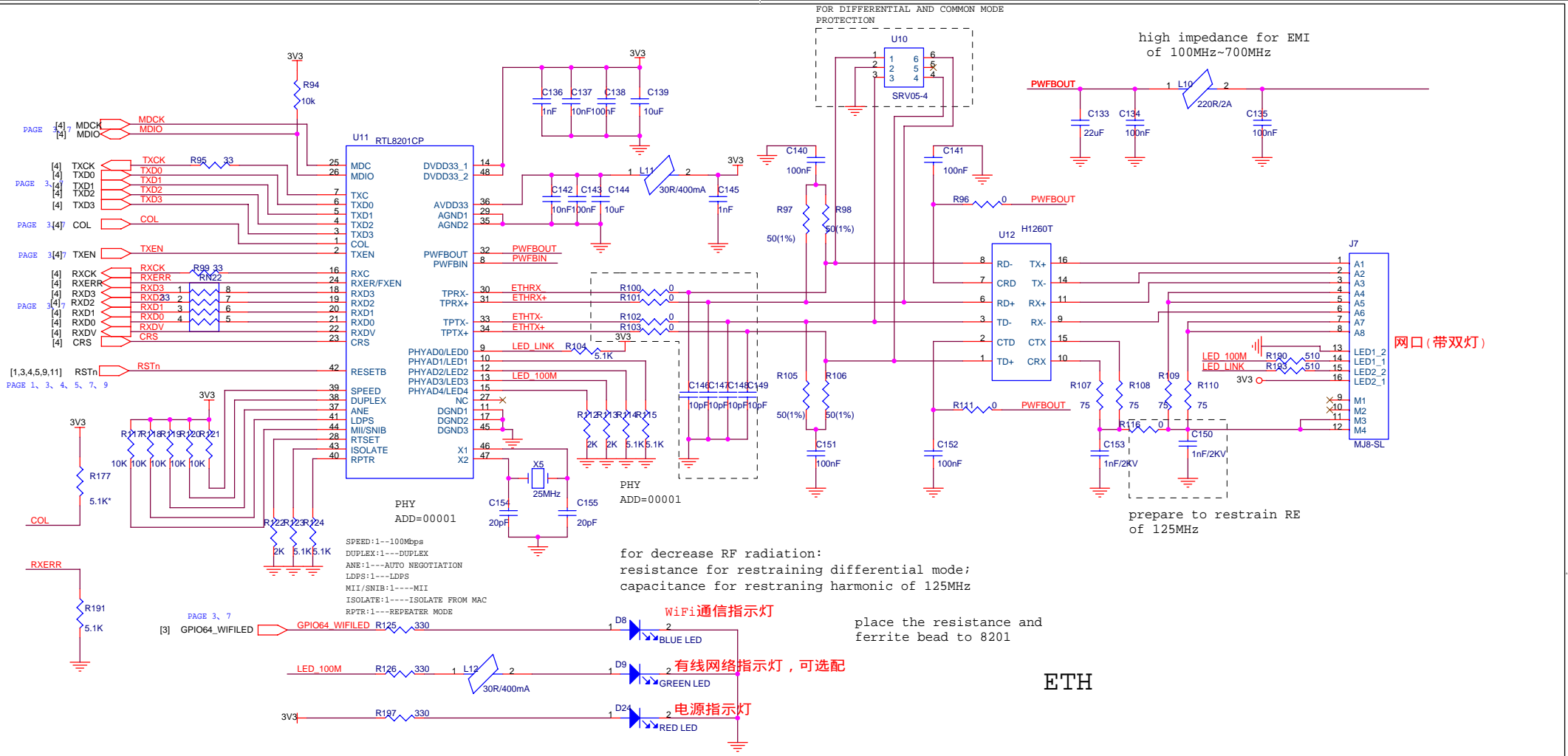

Title		
<Title>		
Size	Document Number	Rev
A3	<Doc>	<RevCode>
Date:	Wednesday, March 18, 2009	Sheet 7 of 12

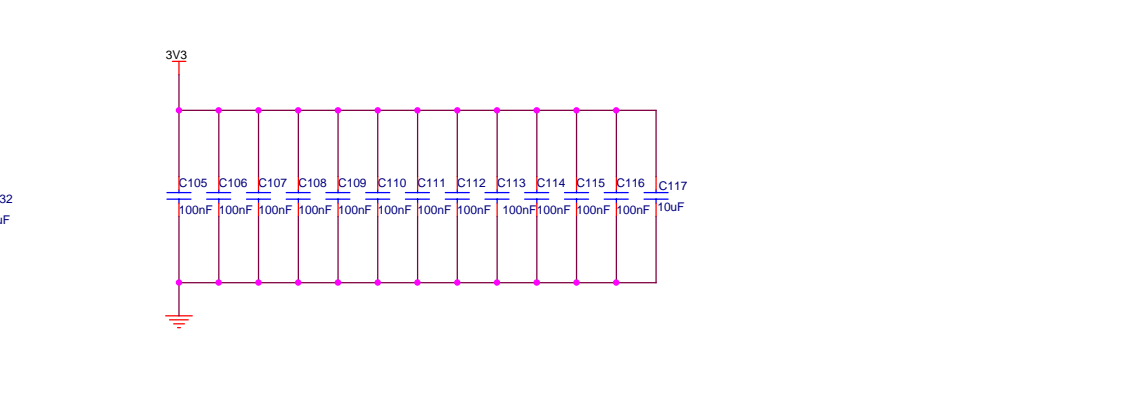
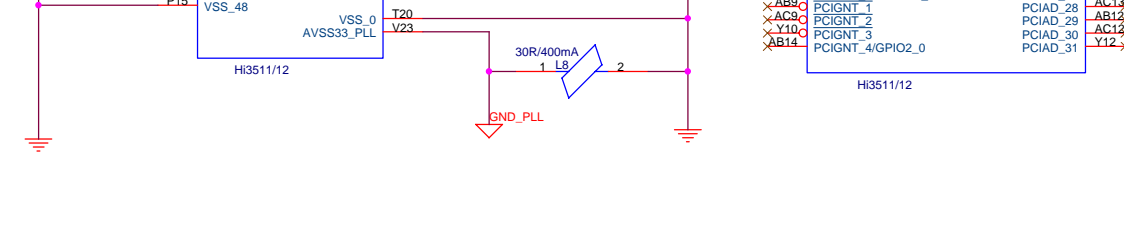
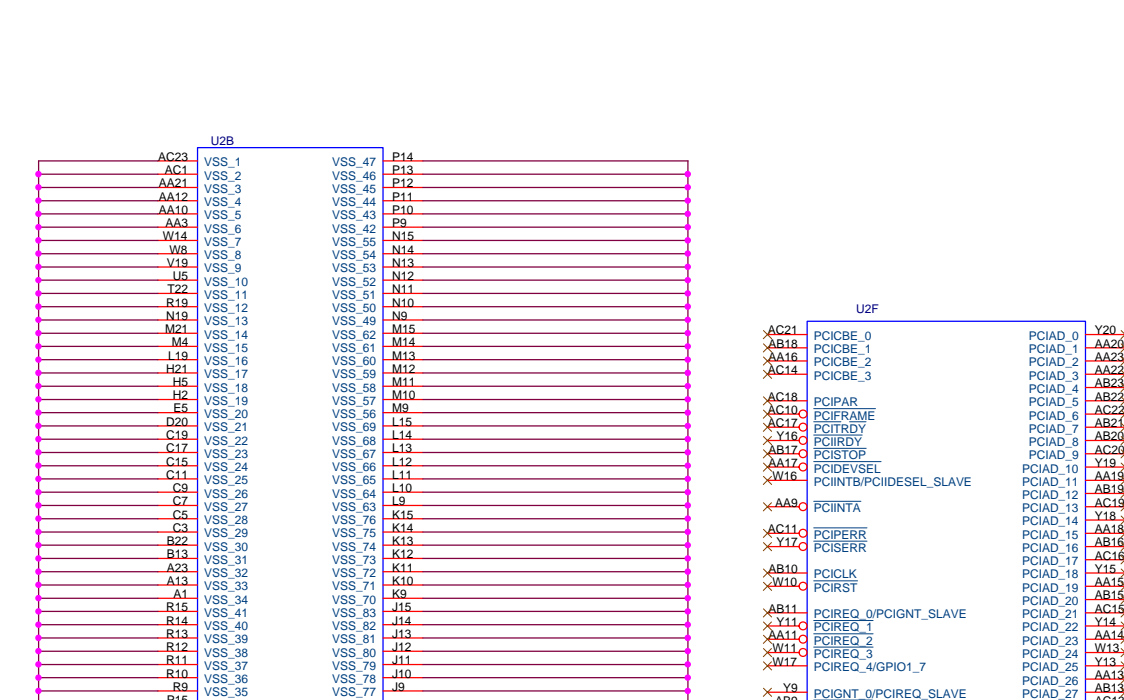
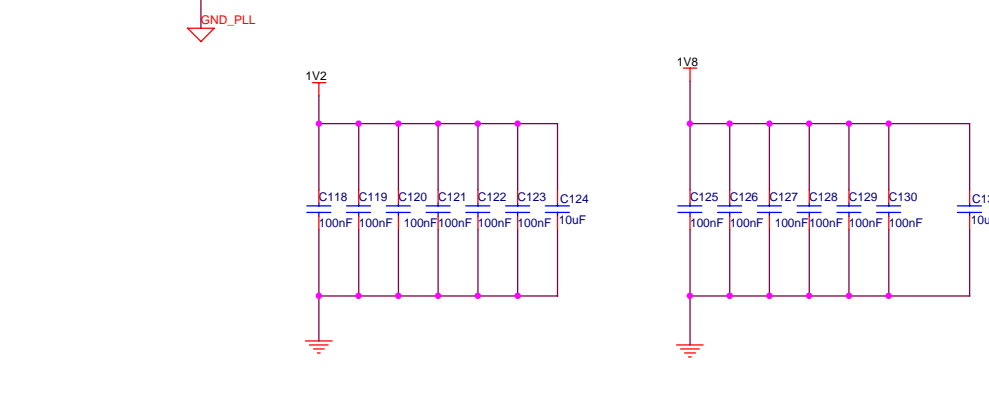
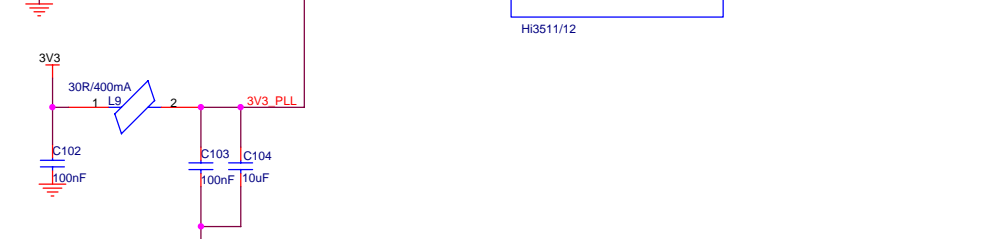
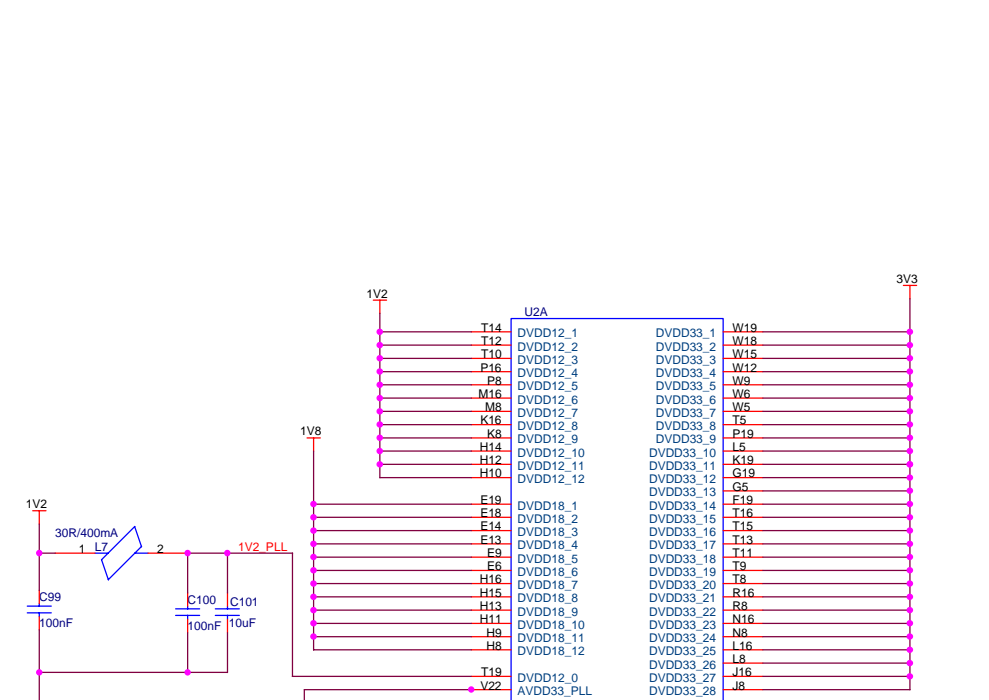

Title		
<Title>		
Size	Document Number	Rev
A3	<Doc>	<RevCode>
Date:	Tuesday, March 17, 2009	Sheet 6 of 12

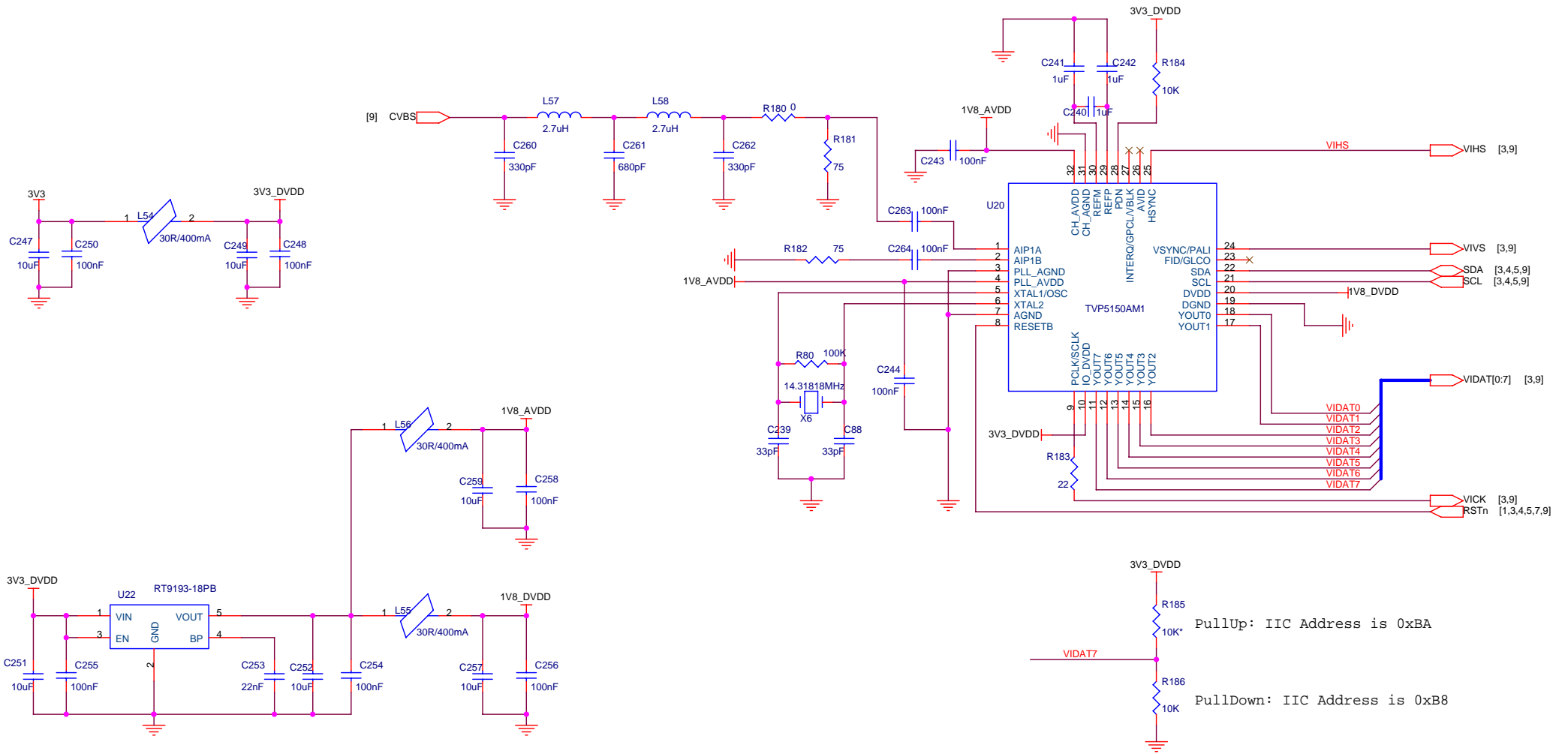

Title		
<Title>		
Size	Document Number	Rev
B	<Doc>	<Rev Code>
Date:	Tuesday, March 17, 2009	Sheet 11 of 12

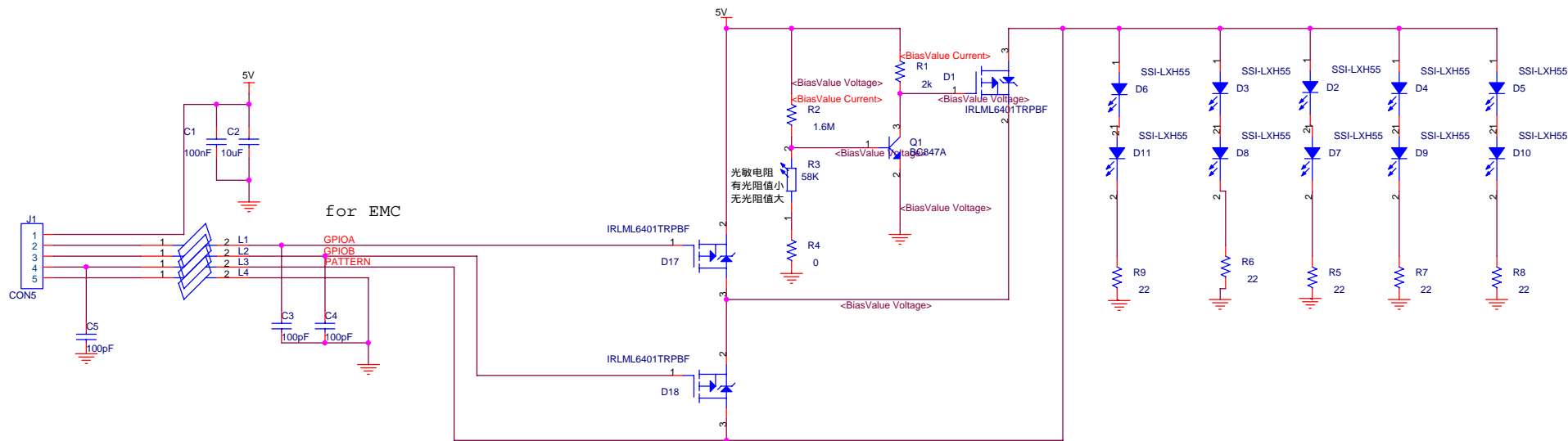

for EMC

光敏电阻
有光阻值小
无光阻值大

GPIOA	GPIOB	function
0	0	open,forced
0	1	auto
1	X	close,forced

Title <Title>		
Size A3	Document Number <Doc>	Rev <RevCode>
Date: Monday, April 06, 2009	Sheet 1	of 1

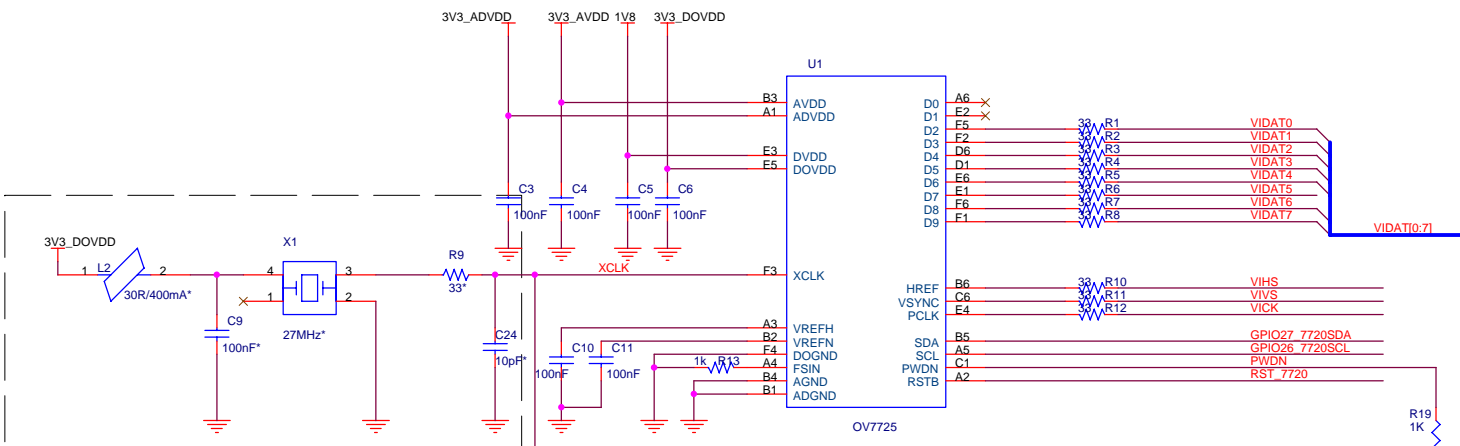

OV7725

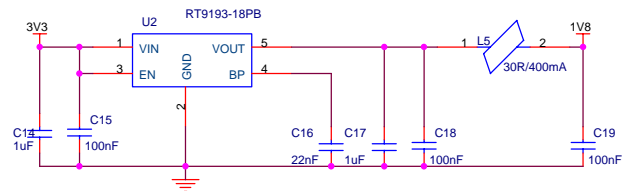
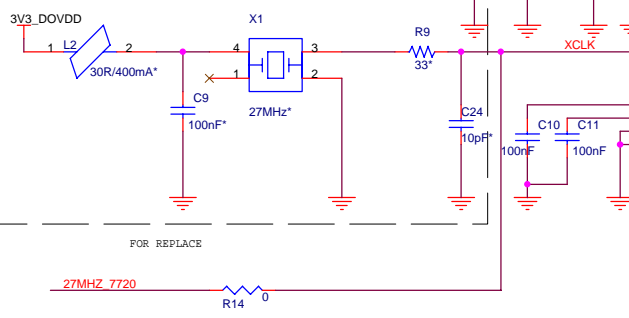
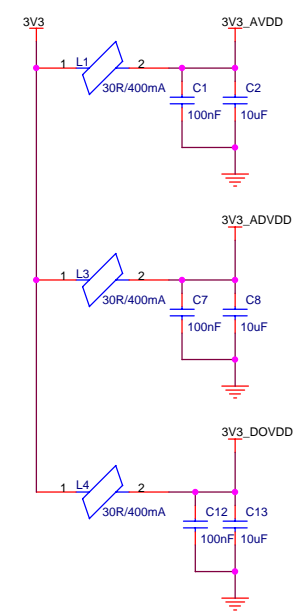

prepared for 7725 core

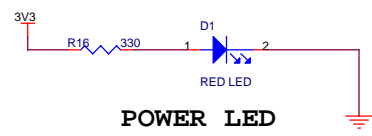

POWER LED

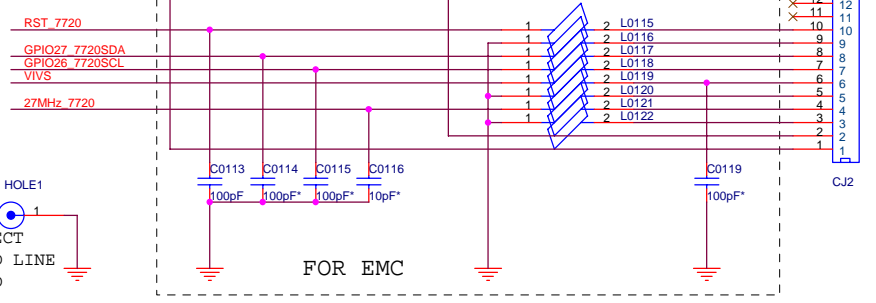
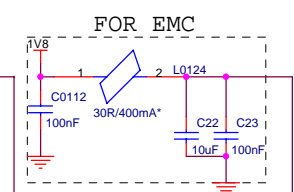
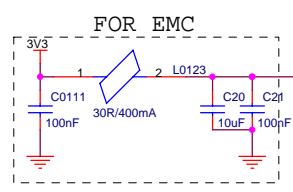
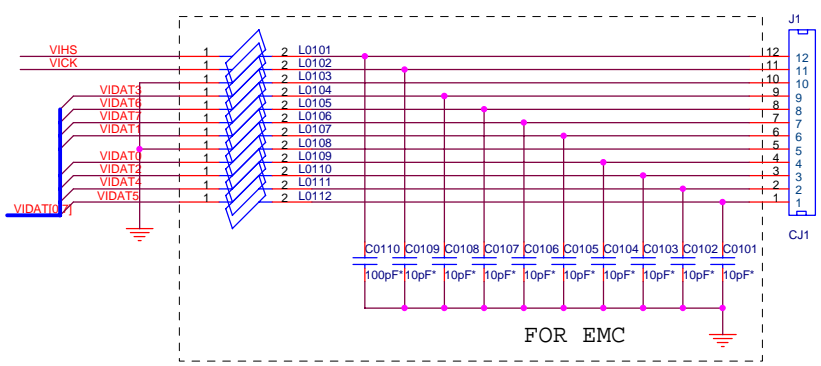

INTERFACE

Title		
<Title>		
Size	Document Number	Rev
A3	<Doc>	<RevCode>
Date:	Wednesday, March 18, 2009	Sheet 1 of 1

FOR EMC

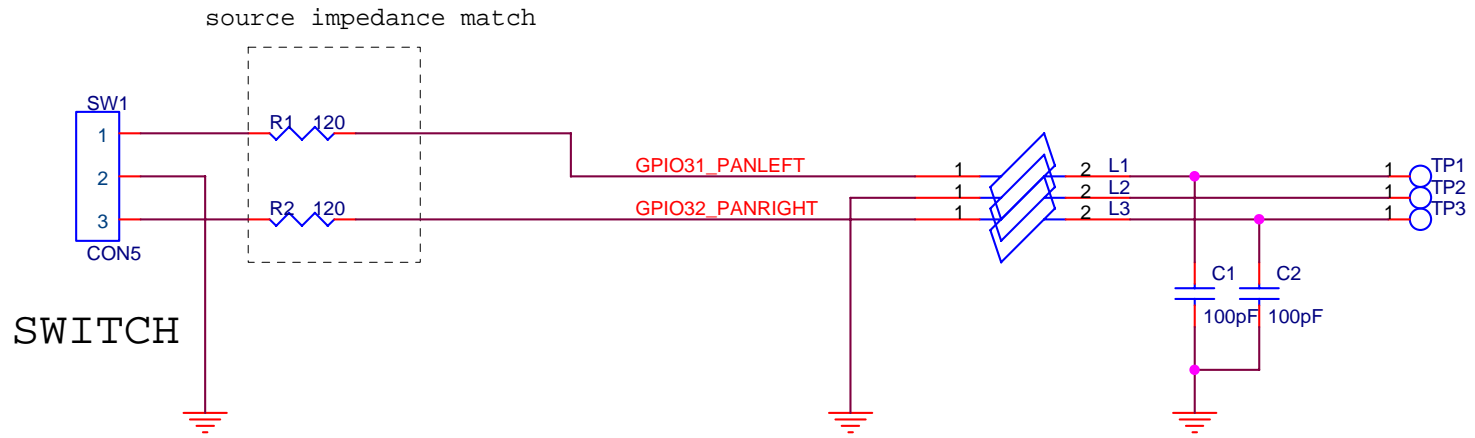

Title		
<Title>		
Size	Document Number	Rev
A	<Doc>	<RevCode>
Date:	Wednesday, March 18, 2009	Sheet 1 of 1