

# Test Report

**FCC ID:ZCB-703GC**

Date of issue: Jun. 12, 2017

Report Number:	MTi170620E114
Sample Description:	IP Camera
Model(s):	K2(703GC), Q2(622GAD), Q3(633GB), Q3S(633GBU), K1(701GA), K2S(730GCU), K3S(704GBU), W1(751GA), W2(754GB), W3(754GA)
Applicant:	Shenzhen Smarteye Digital Electronics Co., Ltd
Address:	#6 Northern Area, Shangxue S&T Industrial Park, Bantian, Longgang, Shenzhen
Date of Test:	Jun 05, 2017 –Jun 10, 2017

**Shenzhen Microtest Co., Ltd.**  
<http://www.mtitest.com>

This test report is valid for the tested samples only. It cannot be reproduced except in full without prior written consent of Shenzhen Microtest Co., Ltd.

<b>TEST RESULT CERTIFICATION</b>	
<b>Applicant's name</b> .....	Shenzhen Smarteye Digital Electronics Co., Ltd.
<b>Address</b> .....	#6 Northern Area, Shangxue S&T Industrial Park, Bantian, Longgang, Shenzhen
<b>Manufacture's Name</b> .....	Shenzhen Smarteye Digital Electronics Co., Ltd.
<b>Address</b> .....	#6 Northern Area, Shangxue S&T Industrial Park, Bantian, Longgang, Shenzhen
<b>Product description</b>	
<b>Product name</b> .....	IP Camera
<b>Model and/or type reference</b> :	K2(703GC)
<b>Serial Model</b> .....	Q2(622GAD), Q3(633GB), Q3S(633GBU), K1(701GA), 2S(730GCU), K3S(704GBU), W1(751GA), W2(754GB), W3(754GA)
<b>Standards</b> .....	FCC Part15.247
<b>Test procedure</b> .....	ANSI C63.4-2014 ; ANSI C63.10-2013

Tested by:

Ace Chai

Jun. 11, 2017

Reviewed by:

*Smith Chen*

Smith Chen

Jun. 11, 2017

Approved by:

*Tom Xue*

Tom Xue

Jun. 11, 2017

**Table of Contents**

	<b>Page</b>
<b>. SUMMARY OF TEST RESULTS</b>	<b>5</b>
TEST FACILITY	6
MEASUREMENT UNCERTAINTY	6
<b>. GENERAL INFORMATION</b>	<b>7</b>
GENERAL DESCRIPTION OF EUT	7
DESCRIPTION OF TEST MODES	9
BLOCK DIGRAM SHOWING THE CONFIGURATION OF SYSTEM TESTED	10
DESCRIPTION OF SUPPORT UNITS(CONDUCTED MODE)	11
EQUIPMENTS LIST FOR ALL TEST ITEMS	12
<b>. EMC EMISSION TEST</b>	<b>13</b>
CONDUCTED EMISSION MEASUREMENT	13
POWER LINE CONDUCTED EMISSION LIMITS	13
TEST PROCEDURE	14
DEVIATION FROM TEST STANDARD	14
TEST SETUP	14
EUT OPERATING CONDITIONS	14
TEST RESULTS	15
RADIATED EMISSION MEASUREMENT	17
RADIATED EMISSION LIMITS	17
TEST PROCEDURE	18
DEVIATION FROM TEST STANDARD	18
TEST SETUP	19
EUT OPERATING CONDITIONS	20
TEST RESULTS (BETWEEN 9KHZ – 30 MHZ)	21
TEST RESULTS (BETWEEN 30MHZ – 1GHZ)	22
TEST RESULTS (1G-25GHZ)	23
<b>. POWER SPECTRAL DENSITY TEST</b>	<b>27</b>
APPLIED PROCEDURES / LIMIT	27
TEST PROCEDURE	27
DEVIATION FROM STANDARD	27
TEST SETUP	27
EUT OPERATION CONDITIONS	27
TEST RESULTS	28
<b>. 6DB EMISSION BANDWIDTH &amp; 99% OCCUPIED BANDWIDTH</b>	<b>34</b>

**Table of Contents**

	<b>Page</b>
<b>APPLIED PROCEDURES / LIMIT</b>	<b>34</b>
<b>TEST PROCEDURE</b>	<b>34</b>
<b>DEVIATION FROM STANDARD</b>	<b>34</b>
<b>TEST SETUP</b>	<b>34</b>
<b>EUT OPERATION CONDITIONS</b>	<b>34</b>
<b>TEST RESULTS</b>	<b>35</b>
<b>. PEAK OUTPUT POWER TEST</b>	<b>41</b>
<b>APPLIED PROCEDURES / LIMIT</b>	<b>41</b>
<b>TEST PROCEDURE</b>	<b>41</b>
<b>DEVIATION FROM STANDARD</b>	<b>41</b>
<b>TEST SETUP</b>	<b>41</b>
<b>EUT OPERATION CONDITIONS</b>	<b>41</b>
<b>TEST RESULTS</b>	<b>42</b>
<b>. 100 KHZ BANDWIDTH OF FREQUENCY BAND EDGE</b>	<b>43</b>
<b>DEVIATION FROM STANDARD</b>	<b>43</b>
<b>TEST SETUP</b>	<b>43</b>
<b>EUT OPERATION CONDITIONS</b>	<b>43</b>
<b>TEST RESULTS</b>	<b>44</b>
<b>. ANTENNA REQUIREMENT</b>	<b>48</b>
<b>STANDARD REQUIREMENT</b>	<b>48</b>
<b>EUT ANTENNA</b>	<b>48</b>

## 1. SUMMARY OF TEST RESULTS

Test procedures according to the technical standards:

FCC Part15 (15.247) , Subpart C			
Standard Section	Test Item	Judgment	Remark
15.207	Conducted Emission	PASS	
15.247 (a)(2)	6dB Bandwidth	PASS	
15.247 (b)	Peak Output Power	PASS	
15.247 (c)	Radiated Spurious Emission	PASS	
15.247 (d)	Power Spectral Density	PASS	
15.205	Band Edge Emission	PASS	
15.203	Antenna Requirement	PASS	

**NOTE:**

(1) "N/A" denotes test is not applicable in this Test Report

**1.1 TEST FACILITY**

Shenzhen Toby Technology Co., Ltd.  
Add.: 10/F.,A Block, Jiada R&D Bldg., No.5 Songpingshan, Road, Science&Technology Park,  
Shenzhen, 518057  
FCC Registration No.:811562

**1.2 MEASUREMENT UNCERTAINTY**

The reported uncertainty of measurement  $y \pm U$ , where expanded uncertainty  $U$  is based on a standard uncertainty multiplied by a coverage factor of  $k=2$ , providing a level of confidence of approximately **95 %**.

No.	Item	Uncertainty
1	Conducted Emission Test	$\pm 1.38\text{dB}$
2	RF power,conducted	$\pm 0.16\text{dB}$
3	Spurious emissions,conducted	$\pm 0.21\text{dB}$
4	All emissions,radiated(<1G)	$\pm 4.68\text{dB}$
5	All emissions,radiated(>1G)	$\pm 4.89\text{dB}$
6	Temperature	$\pm 0.5^{\circ}\text{C}$
7	Humidity	$\pm 2\%$

## 2. GENERAL INFORMATION

### 2.1 GENERAL DESCRIPTION OF EUT

Equipment	IP Camera	
Trade Name	N/A	
Model Name	K2(703GC)	
Serial Model	Q2(622GAD), Q3(633GB), Q3S(633GBU), K1(701GA), 2S(730GCU), K3S(704GBU), W1(751GA), W2(754GB), W3(754GA)	
Model Difference	All of the above models are the same in internal structures, circuits, and components; Only the model name is different in appearance	
Product Description	The EUT is a IP Camera	
	Operation Frequency:	802.11b/g/n20:2412~2462 MHz
	Modulation Type:	11n: BPSK, QPSK, 16QAM, 64QAM with OFDM 11g: BPSK, QPSK, 16QAM, 64QAM, OFDM 11b: DQPSK, DBPSK, DSSS, CCK
	Bit Rate of Transmitter	802.11b:11/5.5/2/1 Mbps 802.11g:54/48/36/24/18/12/9/6Mbps 802.11n:65/52/6.5Mbps
	Number Of Channel	802.11b/g/n20:11CH
	Antenna Designation:	Please see Note 3.
	Output Power(Conducted):	802.11b: 18.73 dBm (Max.) 802.11g: 18.71 dBm (Max.) 802.11n20: 18.37 dBm (Max.)
	Antenna Gain (dBi)	3.3dBi
	Based on the application, features, or specification exhibited in User's Manual, the EUT is considered as an ITE/Computing Device. More details of EUT technical specification, please refer to the User's Manual.	
Channel List	Please refer to the Note 2.	
Adapter information:	Model:SAW06D-050-0800GD Input:100-240V AC 50/60Hz 0.3A Output:5V DC 800mA	
Battery	N/A	
Connecting I/O Port(s)	Please refer to the User's Manual	

Note:

1. For a more detailed features description, please refer to the manufacturer's specifications or the User's Manual.

2. Channel List

Channel List for 802.11b/g/n(20)							
Channel	Frequency (MHz)	Channel	Frequency (MHz)	Channel	Frequency (MHz)	Channel	Frequency (MHz)
01	2412	04	2427	07	2442	10	2457
02	2417	05	2432	08	2447	11	2462
03	2422	06	2437	09	2452		

3.

Table for Filed Antenna

Ant	Brand	Model Name	Antenna Type	Gain (dBi)
A	N/A	N/A	Integral antenna	3.3



## 2.2 DESCRIPTION OF TEST MODES

To investigate the maximum EMI emission characteristics generates from EUT, the test system was pre-scanning tested base on the consideration of following EUT operation mode or test configuration mode which possible have effect on EMI emission level. Each of these EUT operation mode(s) or test configuration mode(s) mentioned above was evaluated respectively.

Pretest Mode	Description
Mode 1	802.11b CH1/ CH6/ CH11
Mode 2	802.11g CH1/ CH6/ CH11
Mode 3	802.11n CH1/ CH6/ CH11
Mode 4	TX Mode

For Conducted Emission	
Final Test Mode	Description
Mode 4	TX Mode

For Radiated Emission	
Final Test Mode	Description
Mode 1	802.11b CH1/ CH6/ CH11
Mode 2	802.11g CH1/ CH6/ CH11
Mode 3	802.11n CH1/ CH6/ CH11

Note:

- (1) The measurements are performed at the highest, middle, lowest available channels.
- (2) The measurements are performed at all Bit Rate of Transmitter, the worst data was reported
- (3) Duty cycle > 98%

### 2.3 BLOCK DIGRAM SHOWING THE CONFIGURATION OF SYSTEM TESTED

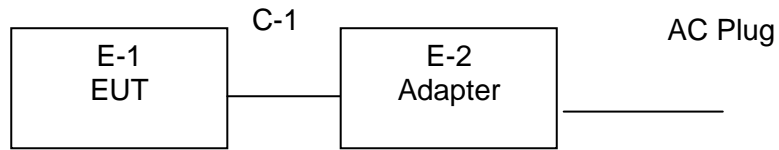

**2.4 DESCRIPTION OF SUPPORT UNITS(CONDUCTED MODE)**

The EUT has been tested as an independent unit together with other necessary accessories or support units. The following support units or accessories were used to form a representative test configuration during the tests.

Item	Equipment	Brand	Model/Type No.	Series No.	Note
E-1	IP Camera	N/A	K2(703GC)	N/A	EUT
E-2	Adapter	N/A	SAW06D-050-0800GD	N/A	

Item	Shielded Type	Ferrite Core	Length	Note
C-1	NO	NO	1.0m	
C-2	NO	NO	0.8m	

Note:

- (1) The support equipment was authorized by Declaration of Confirmation.
- (2) For detachable type I/O cable should be specified the length in cm in 『Length』 column.

## 2.5 EQUIPMENTS LIST FOR ALL TEST ITEMS

For RF conducted test:

Equipment	Manufacturer	Model	Serial No.	Calibration Due
Universal Radio Communication Tester	Rohde&schwarz	CMU200	114587	2017/11/4
Spectrum analyzer	Agilent	E4407B	MY41441082	2017/11/4
Dc Power Supply	GW	GPR-6030D	/	2017/11/4
Temperature & Humidity Chamber	GIANT FORCE	GTH-056P	GF-94454-1	2017/11/14

For RF radiated test:

Equipment	Manufacturer	Model	Serial No.	Calibration Due
Broadband TRILOG Antenna	Schwarabeck	VULB9163	9163-872	2017/11/14
Horn Antenna	Schwarzbeck	BBHA 9120 D	9120D-1145	2017/11/14
Amplifier	HP	8447D	3113A06150	2017/11/4
Amplifier	Agilent	8449B	3008A02400	2017/7/4
Test Receiver	Schwarabeck	ESPI7	100314	2017/11/4
Spectrum analyzer	Agilent	E4407B	MY41441082	2017/11/4
Signal Generator	R&S	SMT 06	832080/007	2017/11/4

Emission test:

Equipment	Manufacturer	Model	Serial No.	Calibration Due
Broadband TRILOG Antenna	Schwarabeck	VULB9163	9163-872	2017/11/14
Horn Antenna	Schwarzbeck	BBHA 9120 D	9120D-1145	2017/11/14
Amplifier	HP	8447D	3113A06150	2017/11/4
Amplifier	Agilent	8449B	3008A02400	2017/7/4
Test Receiver	Schwarabeck	ESPI7	100314	2017/11/4
Spectrum analyzer	Agilent	N9020A	MY49100060	2018/03/03
LISN	R&S	ENV216	1001131	2017/9/25

### 3. EMC EMISSION TEST

#### 3.1 CONDUCTED EMISSION MEASUREMENT

##### 3.1.1 POWER LINE CONDUCTED EMISSION Limits (Frequency Range 150KHz-30MHz)

FREQUENCY (MHz)	Class A (dBuV)		Class B (dBuV)		Standard
	Quasi-peak	Average	Quasi-peak	Average	
0.15 -0.5	79.00	66.00	66 - 56 *	56 - 46 *	CISPR
0.50 -5.0	73.00	60.00	56.00	46.00	CISPR
5.0 -30.0	73.00	60.00	60.00	50.00	CISPR

0.15 -0.5	79.00	66.00	66 - 56 *	56 - 46 *	FCC
0.50 -5.0	73.00	60.00	56.00	46.00	FCC
5.0 -30.0	73.00	60.00	60.00	50.00	FCC

Note:

- (1) The tighter limit applies at the band edges.
- (2) The limit of " \* " marked band means the limitation decreases linearly with the logarithm of the frequency in the range.

The following table is the setting of the receiver

Receiver Parameters	Setting
Attenuation	10 dB
Start Frequency	0.15 MHz
Stop Frequency	30 MHz
IF Bandwidth	9 kHz

**3.1.2 TEST PROCEDURE**

- a. The EUT was placed 0.8 meters from the horizontal ground plane with EUT being connected to the power mains through a line impedance stabilization network (LISN). All other support equipments powered from additional LISN(s). The LISN provide 50 Ohm/ 50uH of coupling impedance for the measuring instrument.
- b. Interconnecting cables that hang closer than 40 cm to the ground plane shall be folded back and forth in the center forming a bundle 30 to 40 cm long.
- c. I/O cables that are not connected to a peripheral shall be bundled in the center. The end of the cable may be terminated, if required, using the correct terminating impedance. The overall length shall not exceed 1 m.
- d. LISN at least 80 cm from nearest part of EUT chassis.
- e. For the actual test configuration, please refer to the related Item –EUT Test Photos.

**3.1.3 DEVIATION FROM TEST STANDARD**

No deviation

**3.1.4 TEST SETUP**

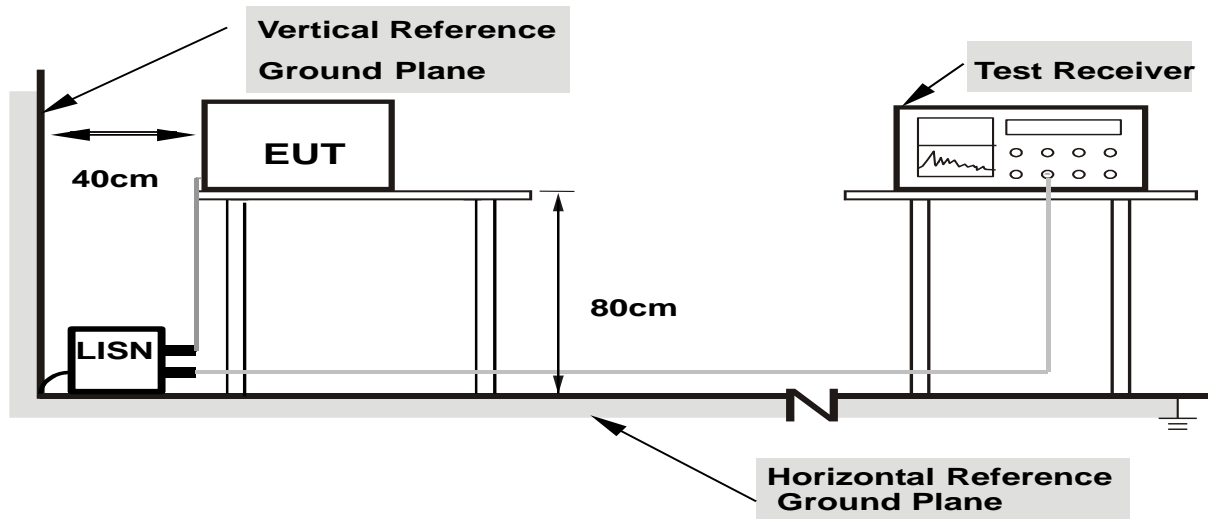

- Note: 1.Support units were connected to second LISN.**  
**2.Both of LISNs (AMN) are 80 cm from EUT and at least 80 from other units and other metal planes**

**3.1.5 EUT OPERATING CONDITIONS**

The EUT was configured for testing in a typical fashion (as a customer would normally use it). The EUT has been programmed to continuously transmit during test. This operating condition was tested and used to collect the included data.

**3.1.6 TEST RESULTS**

EUT :	IP Camera	Model Name. :	K2(703GC)
Temperature :	26 °C	Relative Humidity :	54%
Pressure :	1010hPa	Phase :	L
Test Voltage :	DC 5Vfrom adapter AC 120V/60Hz	Test Mode :	Mode 4

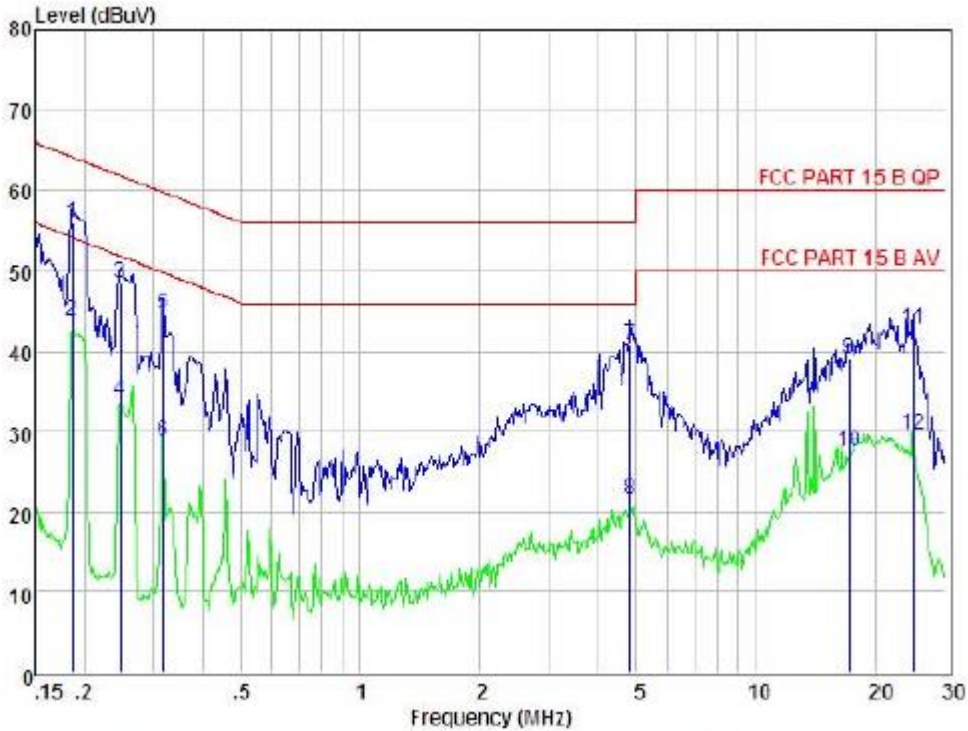

Condition : FCC PART 15 B QP      POL: LINE      Temp: 23.1°C      Hum: 48 %  
 EUT :  
 Model No :  
 Test Mode :  
 Power :  
 Test Engineer :  
 Remark :

Item	Freq MHz	Read Level dBUV	LISN Factor dB	Preamp Factor dB	Cable Loss dB	Level dBUV	Limit dBUV	Margin dBUV	Remark
1	0.186	46.28	0.03	-9.52	0.10	55.93	64.20	-8.27	QP
2	0.186	34.15	0.03	-9.52	0.10	43.80	54.20	-10.40	Average
3	0.247	38.81	0.03	-9.52	0.10	48.46	61.86	-13.40	QP
4	0.247	24.15	0.03	-9.52	0.10	33.80	51.86	-18.06	Average
5	0.317	34.93	0.03	-9.56	0.10	44.62	59.80	-15.18	QP
6	0.317	19.12	0.03	-9.56	0.10	28.81	49.80	-20.99	Average
7	4.822	30.63	0.10	-9.91	0.12	40.76	56.00	-15.24	QP
8	4.822	11.27	0.10	-9.91	0.12	21.40	46.00	-24.60	Average
9	17.291	28.64	0.28	-9.82	0.30	39.04	60.00	-20.96	QP
10	17.291	17.14	0.28	-9.82	0.30	27.54	50.00	-22.46	Average
11	24.790	31.95	0.46	-9.82	0.47	42.70	60.00	-17.30	QP
12	24.790	18.94	0.46	-9.82	0.47	29.69	50.00	-20.31	Average

Remark: Level = Read Level + LISN Factor - Preamp Factor + Cable Loss

EUT :	IP Camera	Model Name. :	K2(703GC)
Temperature :	26 °C	Relative Humidity :	54%
Pressure :	1010hPa	Phase :	N
Test Voltage :	DC 5Vfrom adapter AC 120V/60Hz	Test Mode :	Mode 4

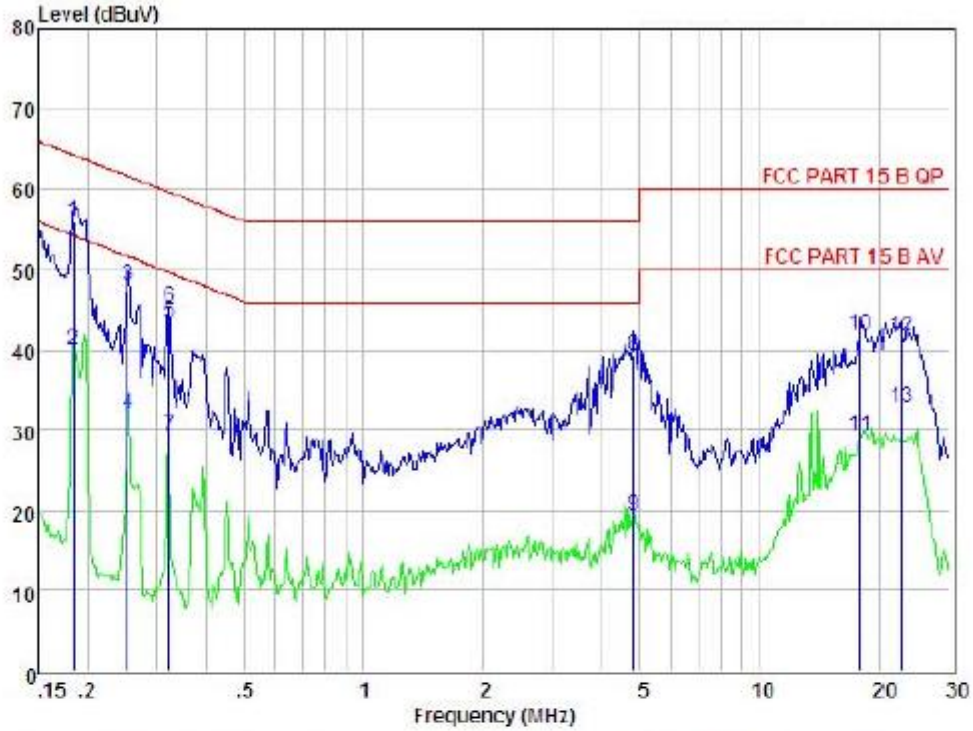

Condition : FCC PART 15 B QP      POL: NEUTRAL      Temp: 23.1°C      Hum: 49 %  
 EUT :  
 Model No :  
 Test Mode :  
 Power :  
 Test Engineer :  
 Remark :

Item	Freq MHz	Read Level dBuV	LISN Factor dB	Preamp Factor dB	Cable Loss dB	Level dBuV	Limit dBuV	Margin dBuV	Remark
1	0.184	46.34	0.03	-9.32	0.10	55.99	64.28	-8.29	QP
2	0.184	30.32	0.03	-9.32	0.10	39.97	54.28	-14.31	Average
3	0.253	38.34	0.03	-9.56	0.10	48.03	61.64	-13.61	QP
4	0.253	22.35	0.03	-9.56	0.10	32.04	51.64	-19.60	Average
5	0.322	33.60	0.03	-9.56	0.10	43.29	59.66	-16.37	QP
6	0.322	35.60	0.03	-9.56	0.10	45.29	59.66	-14.37	QP
7	0.322	19.53	0.03	-9.56	0.10	29.22	49.66	-20.44	Average
8	4.822	29.11	0.10	-9.91	0.12	39.24	56.00	-16.76	QP
9	4.822	9.26	0.10	-9.91	0.12	19.39	46.00	-26.61	Average
10	18.039	31.48	0.29	-9.82	0.32	41.91	60.00	-18.09	QP
11	18.039	18.77	0.29	-9.82	0.32	29.20	50.00	-20.80	Average
12	22.655	30.91	0.41	-9.81	0.42	41.55	60.00	-18.45	QP
13	22.655	22.14	0.41	-9.81	0.42	32.78	50.00	-17.22	Average

Remark: Level = Read Level + LISN Factor - Preamp Factor + Cable Loss



### 3.2 RADIATED EMISSION MEASUREMENT

#### 3.2.1 RADIATED EMISSION LIMITS (Frequency Range 9kHz-1000MHz)

20dBc in any 100 kHz bandwidth outside the operating frequency band. In case the emission fall within the restricted band specified on 15.205(a), then the 15.209(a) limit in the table below has to be followed.

Frequencies (MHz)	Field Strength (microrvolts/meter)	Measurement Distance (meters)
0.009~0.490	2400/F(KHz)	300
0.490~1.705	24000/F(KHz)	30
1.705~30.0	30	30
30~88	100	3
88~216	150	3
216~960	200	3
Above 960	500	3

Spectrum Parameter	Setting
Attenuation	Auto
Start Frequency	1000 MHz
Stop Frequency	10th carrier harmonic
RB / VB (emission in restricted band)	1 MHz / 1 MHz for Peak, RMS for Average

Receiver Parameter	Setting
Attenuation	Auto
Start ~ Stop Frequency	9kHz~150kHz / RB 200Hz for QP
Start ~ Stop Frequency	150kHz~30MHz / RB 9kHz for QP
Start ~ Stop Frequency	30MHz~1000MHz / RB 120kHz for QP

### 3.2.2 TEST PROCEDURE

- a. The measuring distance of at 3 m shall be used for measurements at frequency up to 1GHz. For frequencies above 1GHz, any suitable measuring distance may be used.
- b. The EUT was placed on the top of a rotating table 0.8 meters above the ground at a 3 meter open area test site. The table was rotated 360 degrees to determine the position of the highest radiation.
- c. The height of the equipment or of the substitution antenna shall be 0.8 m; the height of the test antenna shall vary between 1 m to 4 m. Both horizontal and vertical polarizations of the antenna are set to make the measurement.
- d. The initial step in collecting conducted emission data is a spectrum analyzer peak detector mode pre-scanning the measurement frequency range. Significant peaks are then marked and then Quasi Peak detector mode re-measured.
- e. If the Peak Mode measured value compliance with and lower than Quasi Peak Mode Limit, the EUT shall be deemed to meet QP Limits and then no additional QP Mode measurement performed.
- f. For the actual test configuration, please refer to the related Item –EUT Test Photos.

Note:

Both horizontal and vertical antenna polarities were tested and performed pretest to three orthogonal axis. The worst case emissions were reported

### 3.2.3 DEVIATION FROM TEST STANDARD

No deviation

### 3.2.4 TEST SETUP

#### (A) Radiated Emission Test-Up Frequency Below 30MHz

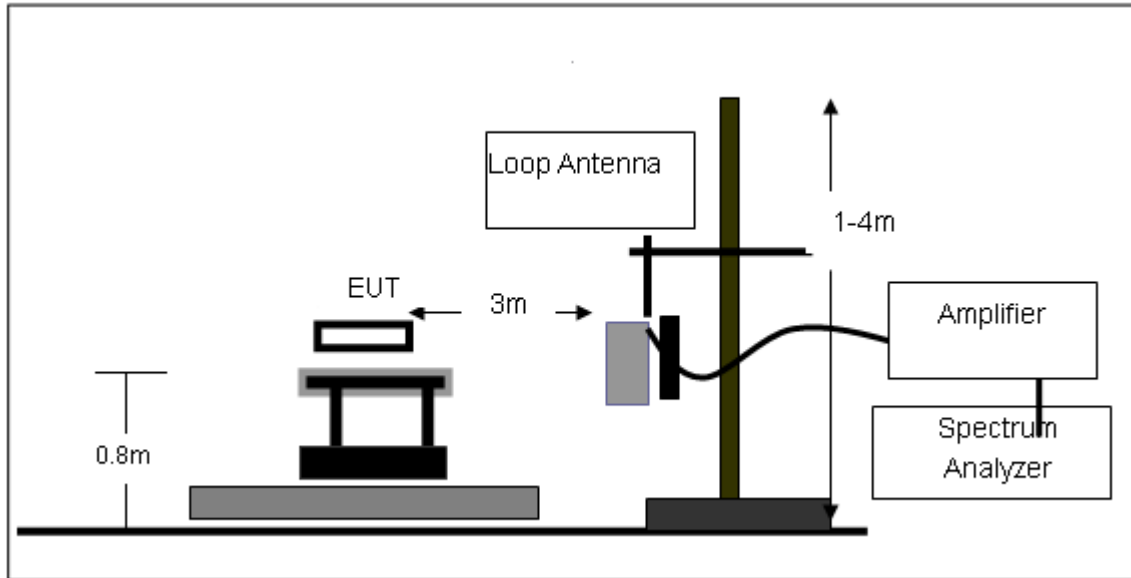

#### (B) Radiated Emission Test-Up Frequency 30MHz~1GHz

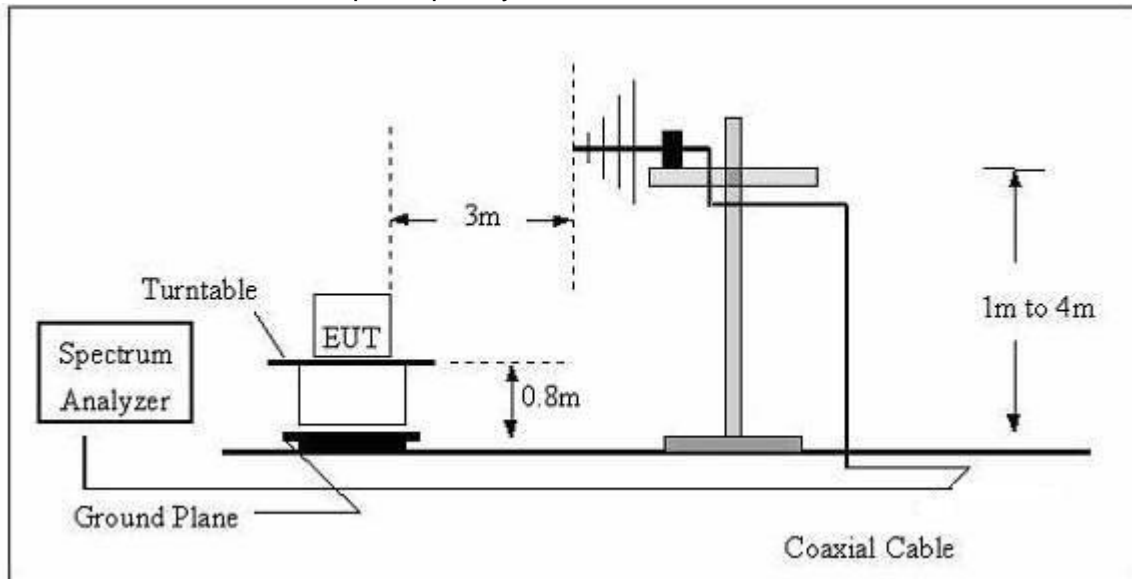

(C) Radiated Emission Test-Up Frequency Above 1GHz

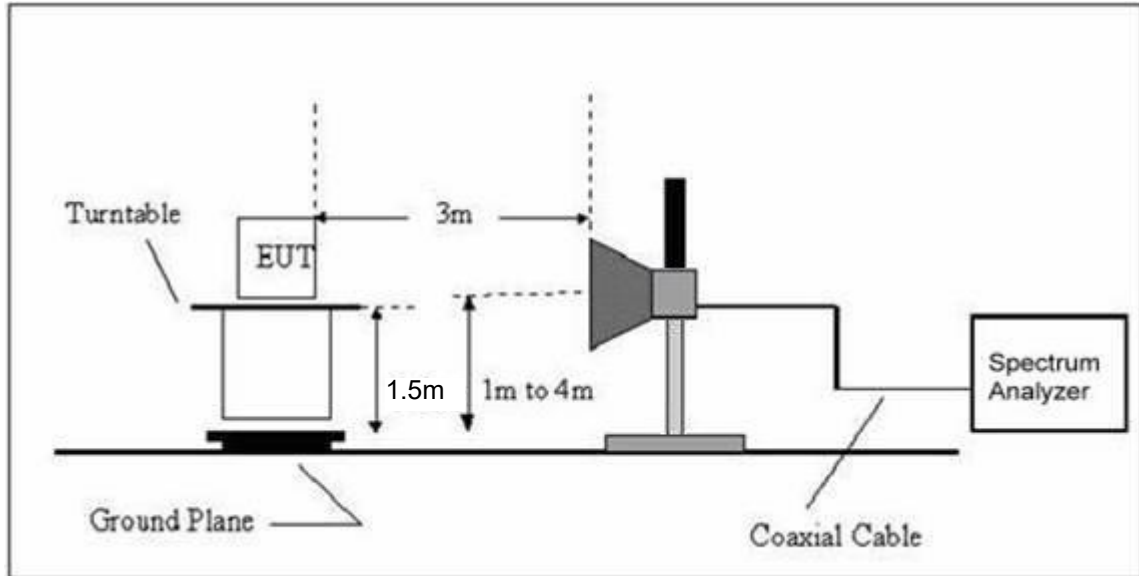

**3.2.5 EUT OPERATING CONDITIONS**

The EUT tested system was configured as the statements of 2.4 Unless otherwise a special operating condition is specified in the follows during the testing.

**3.2.6 TEST RESULTS (BETWEEN 9KHZ – 30 MHZ)**

EUT:	IP Camera	Model Name. :	K2(703GC)
Temperature:	20 °C	Relative Humidity:	48%
Pressure:	1010 hPa	Test Voltage :	DC 5Vfrom adapter AC 120V/60Hz
Test Mode :	TX	Polarization :	--

Freq.	Reading	Limit	Margin	State
(MHz)	(dBuV/m)	(dBuV/m)	(dB)	P/F
--	--	--	--	PASS
--	--	--	--	PASS

**NOTE:**

The amplitude of spurious emissions which are attenuated by more than 20dB below the permissible value has no need to be reported.

Distance extrapolation factor =  $40 \log(\text{specific distance}/\text{test distance})(\text{dB})$ ;

Limit line = specific limits(dBuv) + distance extrapolation factor.

**3.2.7 TEST RESULTS (BETWEEN 30MHZ – 1GHZ)**

EUT :	IP Camera	Model Name :	K2(703GC)
Temperature :	20 °C	Relative Humidity :	48%
Pressure:	1010 hPa	Test Voltage :	DC 5Vfrom adapter
Test Mode :	TX		

Polar (H/V)	Frequency	Meter Reading	Factor	Emission Level	Limits	Margin	Detector Type
	(MHz)	(dBuV)	(dB)	(dBuV/m)	(dBuV/m)	(dB)	
V	119.4360	16.54	12.08	28.62	43.5	14.88	QP
V	128.1129	16.29	12.2	28.49	43.5	15.01	QP
V	170.7926	20.98	10.35	31.33	43.5	12.17	QP
V	341.9786	12.21	16.19	28.4	46	17.6	QP
V	468.8761	17.67	19.69	37.36	46	8.64	QP
V	935.5462	9.09	29.42	38.51	46	7.49	QP
H	170.7923	27.12	10.35	37.47	43.5	6.03	QP
H	341.9786	25.31	16.19	41.5	46	4.5	QP
H	468.8761	21.65	19.69	41.34	46	4.66	QP
H	726.8052	14.912	26	40.912	46	5.088	QP

**Remark:**

Absolute Level= ReadingLevel+ Factor, Margin= Absolute Level- Limit

Factor = Antenna Factor + Cable Loss – Pre-amplifier.

Factor added by measurement software automatically

**3.2.8 TEST RESULTS (1G-25GHZ)**

**802.11b**

Normal Voltage

Polar (H/V)	Frequency	Meter Reading	Factor	Emission Level	Limits	Margin	Detector Type
	(MHz)	(dBuV)	(dB)	(dBuV/m)	(dBuV/m)	(dB)	
<b>Low Channel (2412 MHz)</b>							
Vertical	2491.777	59.26	-11.65	47.61	74	26.39	Pk
Horizontal	2498.247	56.16	-12.73	43.43	74	30.57	Pk
Vertical	4824.184	56.26	-3.6	52.66	74	21.34	Pk
Horizontal	4824.184	56.26	-9.23	47.03	74	26.97	Pk
Vertical	1485.838	59.96	-17.1	42.86	74	31.14	Pk
Vertical	1636.784	59.65	-16.06	43.59	74	30.41	Pk
Vertical	2095.928	58.46	-11.88	46.58	74	27.42	Pk
Horizontal	1074.301	60.19	-19.69	40.5	74	33.5	Pk
Horizontal	1483.178	59.18	-17.09	42.09	74	31.91	Pk
Horizontal	1895.832	56.2	-14.25	41.95	74	32.05	Pk
<b>Mid Channel (2437 MHz)</b>							
Vertical	2474.777	55.97	-11.65	44.32	74	29.68	Pk
Horizontal	2474.144	56.66	-9.37	47.29	74	26.71	Pk
Vertical	4874.425	56.04	-6.15	49.89	74	24.11	Pk
Horizontal	4874.979	56.04	-6.83	49.21	74	24.79	Pk
Vertical	1433.535	63.03	-17.12	45.91	74	28.09	Pk
Vertical	1636.784	60.36	-16.06	44.3	74	29.7	Pk
Vertical	2284.166	54.1	-12.83	41.27	74	32.73	Pk
Horizontal	1280.515	59.76	-17.82	41.94	74	32.06	Pk
Horizontal	1636.784	58.59	-16.06	42.53	74	31.47	Pk
Horizontal	1892.438	58.71	-14.28	44.43	74	29.57	Pk
<b>High Channel (2462 MHz)</b>							
Vertical	2453.883	56.28	-12.91	43.37	74	30.63	Pk
Horizontal	2453.839	56.28	-11.59	44.69	74	29.31	Pk
Vertical	4926.325	52.79	-9.22	43.57	74	30.43	Pk
Horizontal	4926.683	52.79	-3.64	49.15	74	24.85	Pk
Vertical	1187.688	57.31	-18.27	39.04	74	34.96	Pk
Vertical	1636.784	56.12	-16.06	40.06	74	33.94	Pk
Vertical	2084.693	53.71	-11.99	41.72	74	32.28	Pk
Horizontal	1534.540	56.37	-16.94	39.43	74	34.57	Pk
Horizontal	1786.985	56.08	-15.04	41.04	74	32.96	Pk
Horizontal	1892.438	55.96	-14.28	41.68	74	32.32	Pk

**802.11g**

Normal Voltage

Polar (H/V)	Frequency	Meter Reading	Factor	Emission Level	Limits	Margin	Detector Type
	(MHz)	(dBuV)	(dB)	(dBuV/m)	(dBuV/m)	(dB)	
<b>operation frequency:2412</b>							
V	4824.428	54.3	-3.75	50.55	74	23.45	Pk
V	4824.428	33.9	-3.75	30.15	54	23.85	AV
H	4824.529	50.48	-3.74	46.74	74	27.26	Pk
H	4824.529	34.12	-3.74	30.38	54	23.62	AV
<b>operation frequency:2437</b>							
V	4873.548	54.35	-3.75	50.6	74	23.4	Pk
V	4873.548	33.95	-3.75	30.2	54	23.8	AV
H	4875.279	50.53	-3.74	46.79	74	27.21	Pk
H	4875.279	34.17	-3.74	30.43	54	23.57	AV
<b>operation frequency:2462</b>							
V	4924.358	54.41	-3.75	50.66	74	23.34	pk
V	4924.358	34.01	-3.75	30.26	54	23.74	AV
H	4924.591	50.59	-3.74	46.85	74	27.15	pk
H	4924.591	34.23	-3.74	30.49	54	23.51	AV
<b>Remark:</b>							
Absolute Level= Reading Level+ Factor, Margin= Absolute Level - Limit							



**802.11n(20)**

Normal Voltage

Polar (H/V)	Frequency	Meter Reading	Factor	Emission Level	Limits	Margin	Detector Type
	(MHz)	(dBuV)	(dB)	(dBuV/m)	(dBuV/m)	(dB)	
<b>operation frequency:2412</b>							
V	4824.428	50.59	-3.53	47.06	74	26.94	Pk
H	4824.529	53.64	-3.54	50.1	74	23.9	Pk
<b>operation frequency:2437</b>							
V	4873.548	50.99	-3.64	47.35	74	26.65	Pk
H	4875.279	53.28	-3.64	49.64	74	24.36	Pk
<b>operation frequency:2462</b>							
V	4924.358	52.05	-3.75	48.3	74	25.7	pk
H	4924.591	50.91	-3.74	47.17	74	26.83	pk
<b>Remark:</b>							
Absolute Level= Reading Level+ Factor, Margin= Absolute Level - Limit							

Note:The PK value is less than the AV value, AV value is not required  
Factor added by measurement software automatically.

**BAND EDGE(Radiated)**

Frequency (MHz)	Meter Reading (dBμV)	Factor (dB)	Emission Level (dBμV/m)	Limits (dBμV/m)	Margin (dB)	Detector Type	Comment
<b>802.11b</b>							
2390	56.47	-13.06	43.41	74	30.59	peak	Vertical
2390	57.57	-13.06	44.51	74	29.49	peak	Horizontal
2483.5	56.9	-12.78	44.12	74	29.88	peak	Vertical
2483.5	54.03	-12.78	41.25	74	32.75	peak	Horizontal
<b>802.11g</b>							
2390	56.87	-13.06	43.81	74	30.19	peak	Vertical
2390	57.32	-13.06	44.26	74	29.74	peak	Horizontal
2483.5	57.96	-12.78	45.18	74	28.82	peak	Vertical
2483.5	58.22	-12.78	45.44	74	28.56	peak	Horizontal
<b>802.11n20</b>							
2390	57.65	-13.06	44.59	74	29.41	peak	Vertical
2390	57.96	-13.06	44.9	74	29.1	peak	Horizontal
2483.5	57.68	-12.78	44.9	74	29.1	peak	Vertical
2483.5	56.11	-12.78	43.33	74	30.67	peak	Horizontal

NOTE: The PK value is less than the AV value, AV value is not required.

## 4. POWER SPECTRAL DENSITY TEST

### 4.1 APPLIED PROCEDURES / LIMIT

FCC Part15 (15.247) , Subpart C				
Section	Test Item	Limit	Frequency Range (MHz)	Result
15.247	Power Spectral Density	8 dBm (in any 3KHz)	2400-2483.5	PASS

#### 4.1.1 TEST PROCEDURE

1. Set analyzer center frequency to DTS channel center frequency.
2. Set the span to 1.5 times the DTS channel bandwidth.
3. Set the RBW  $\geq$  3 kHz.
4. Set the VBW  $\geq$  3 x RBW.
5. Detector = peak.
6. Sweep time = auto couple.
7. Trace mode = max hold.
8. Allow trace to fully stabilize.
9. Use the peak marker function to determine the maximum amplitude level.
10. If measured value exceeds limit, reduce RBW (no less than 3 kHz) and repeat.

#### 4.1.2 DEVIATION FROM STANDARD

No deviation.

#### 4.1.3 TEST SETUP

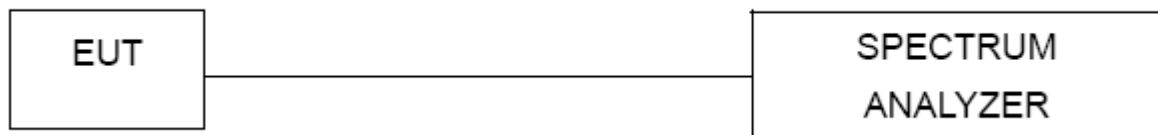

#### 4.1.4 EUT OPERATION CONDITIONS

The EUT tested system was configured as the statements of 2.1 Unless otherwise a special operating condition is specified in the follows during the testing.

**4.1.5 TEST RESULTS**

EUT :	IP Camera	Model Name :	K2(703GC)
Temperature :	25 °C	Relative Humidity :	60%
Pressure :	1015 hPa	Test Voltage :	DC 5Vfrom adapter
Test Mode :	TX b Mode /CH01, CH06, CH11		

Frequency	Power Density (dBm)	Limit (dBm)	Result
2412 MHz	-7.324	8	PASS
2437 MHz	-6.948	8	PASS
2462 MHz	-7.684	8	PASS

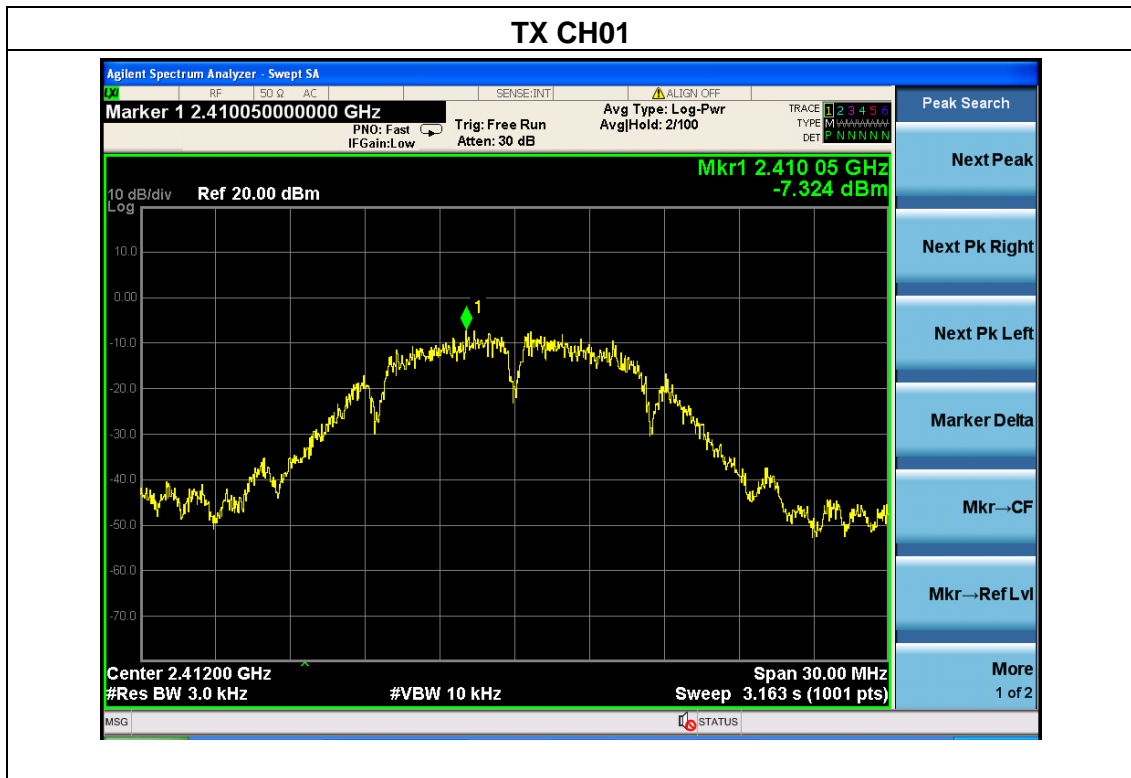

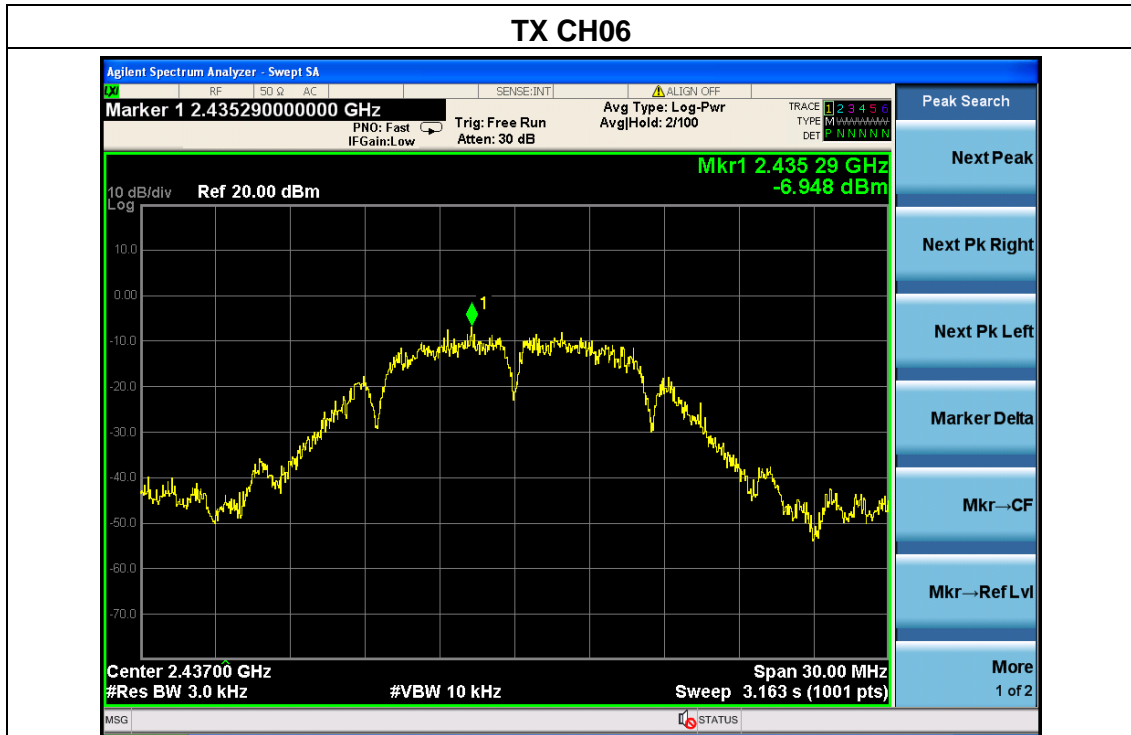

EUT :	IP Camera	Model Name :	K2(703GC)
Temperature :	25 °C	Relative Humidity :	60%
Pressure :	1015 hPa	Test Voltage :	DC 5Vfrom adapter
Test Mode :	TX g Mode /CH01, CH06, CH11		

Frequency	Power Density (dBm)	Limit (dBm)	Result
2412 MHz	-11.716	8	PASS
2437 MHz	-11.238	8	PASS
2462 MHz	-11.221	8	PASS

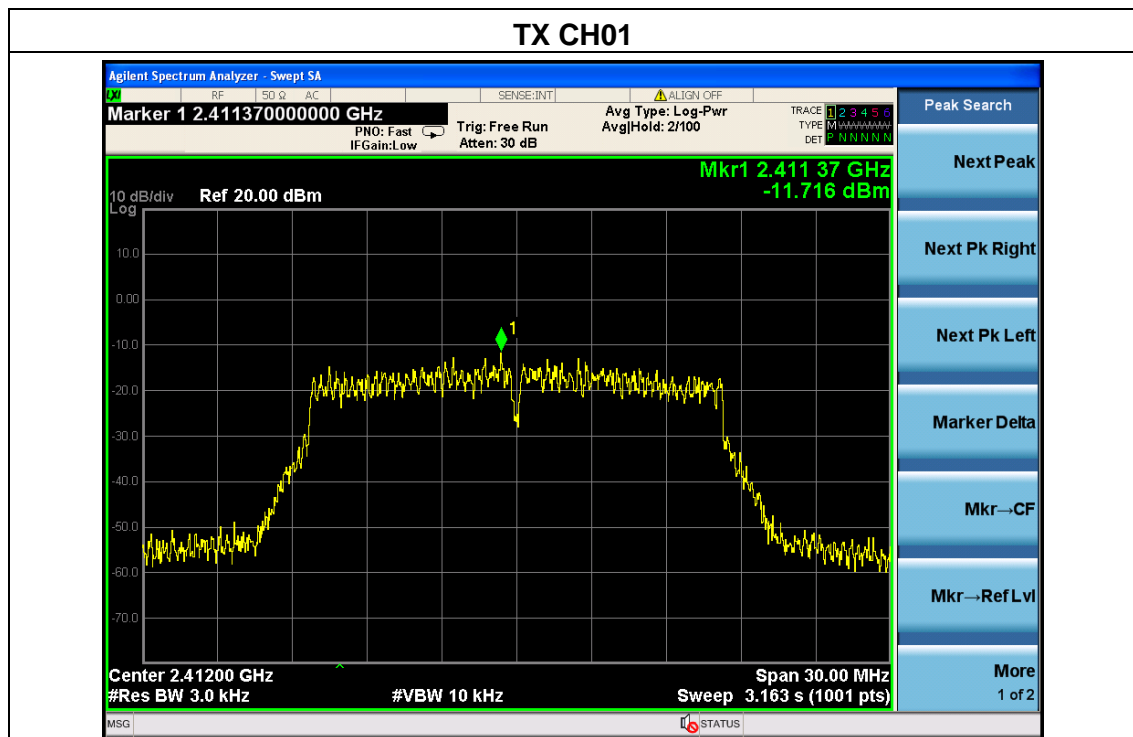

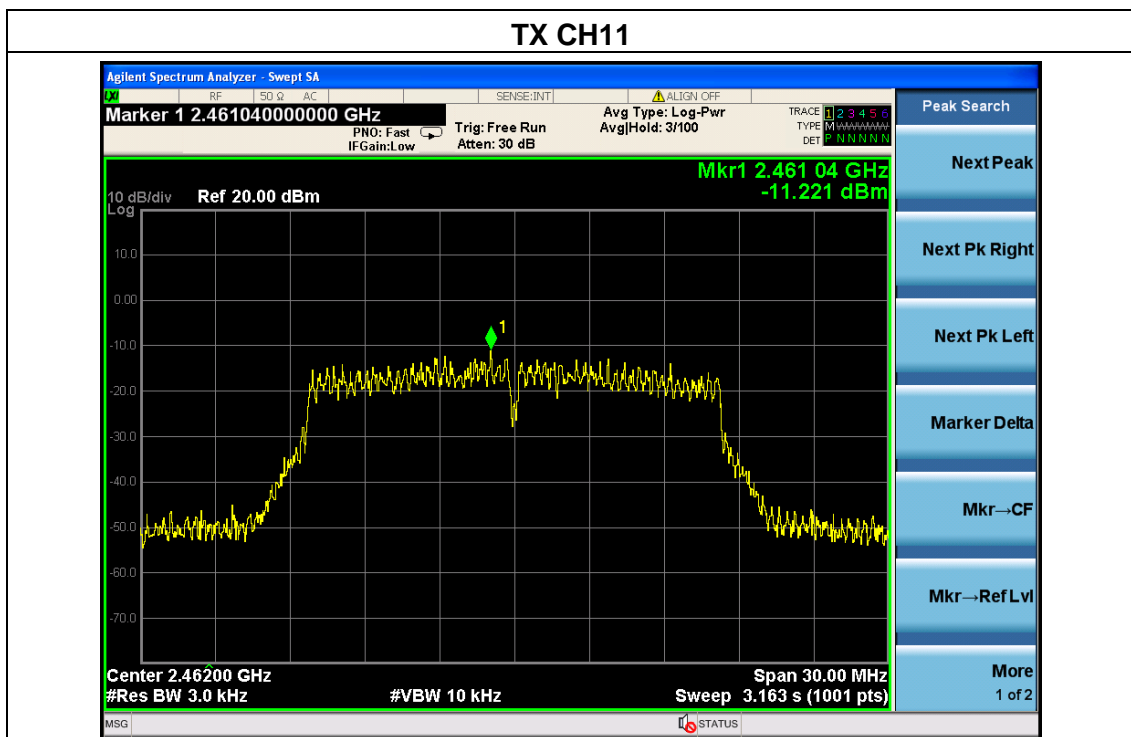
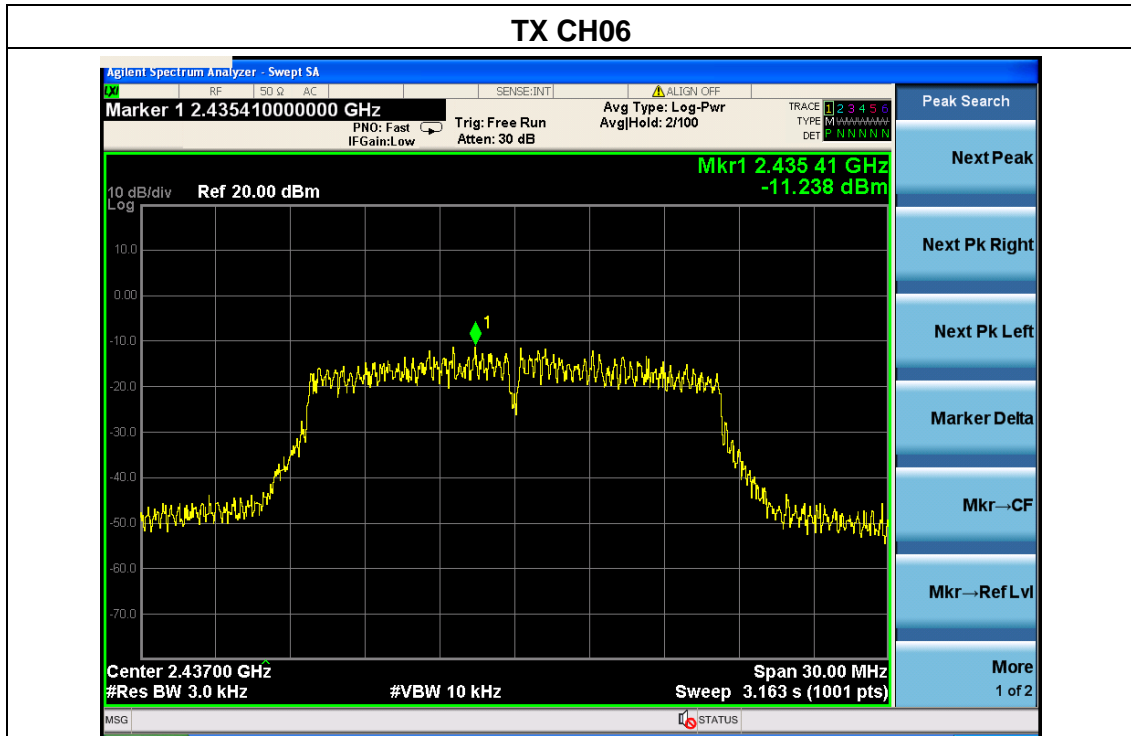

EUT :	IP Camera	Model Name :	K2(703GC)
Temperature :	25 °C	Relative Humidity :	60%
Pressure :	1015 hPa	Test Voltage :	DC 5Vfrom adapter
Test Mode :	TX n20 Mode /CH01, CH06, CH11		

Frequency	Power Density (dBm)	Limit (dBm)	Result
2412 MHz	-11.223	8	PASS
2437 MHz	-10.389	8	PASS
2462 MHz	-11.700	8	PASS

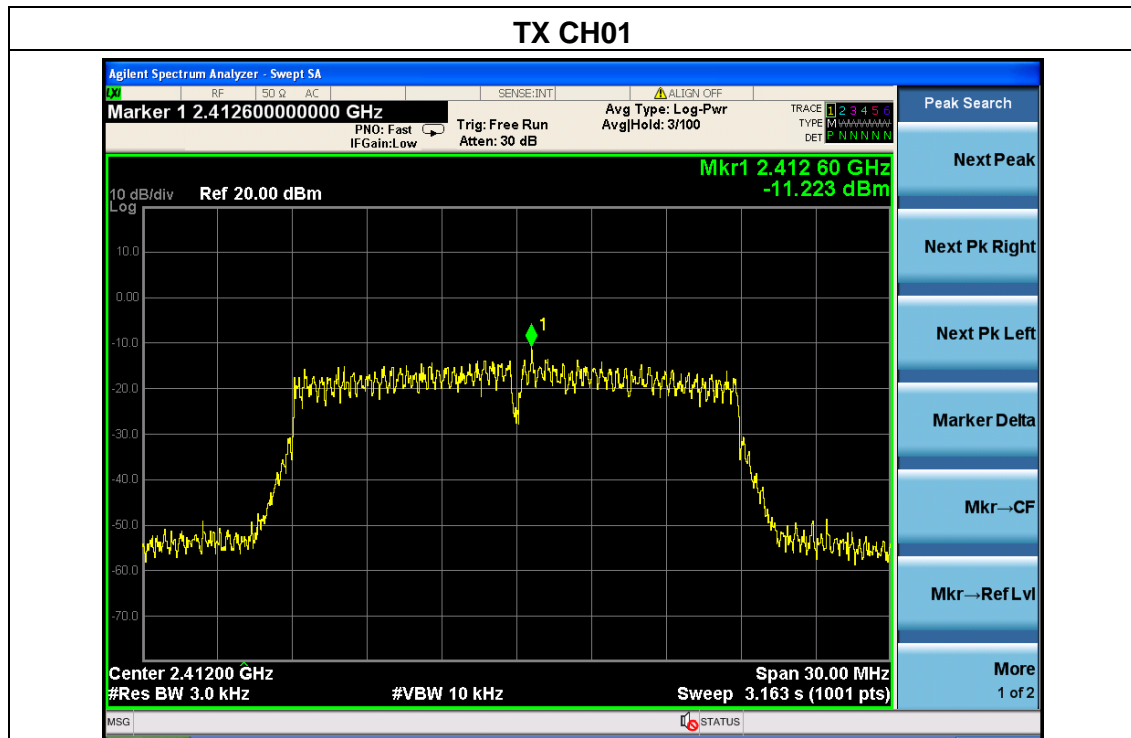



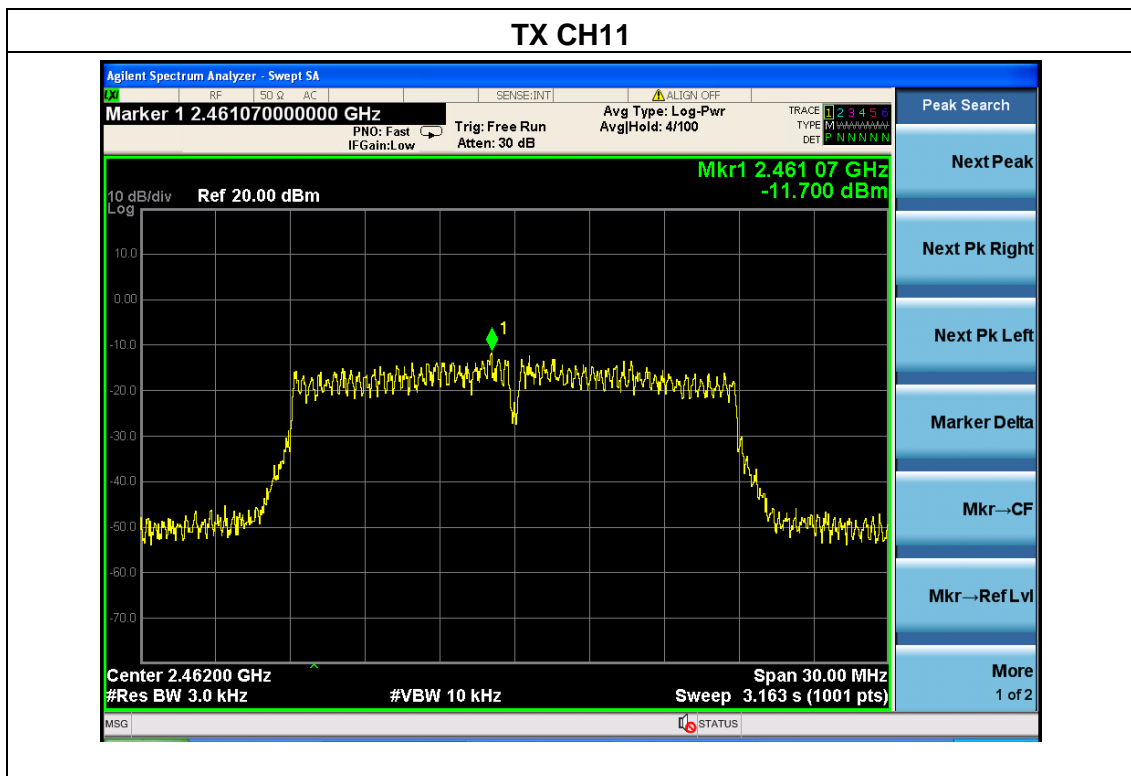
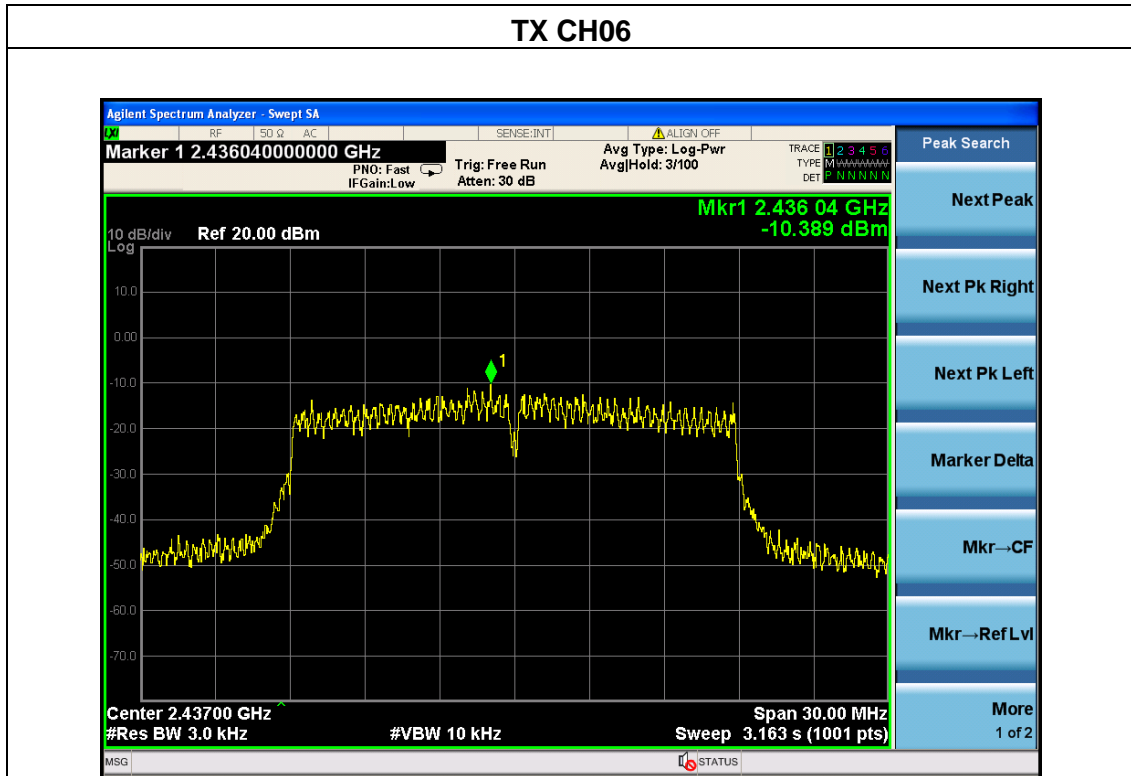

## 5. 6DB EMISSION BANDWIDTH & 99% OCCUPIED BANDWIDTH

### 5.1 APPLIED PROCEDURES / LIMIT

FCC Part15 (15.247) , Subpart C				
Section	Test Item	Limit	Frequency Range (MHz)	Result
15.247(a)(2)	Bandwidth	$\geq 500\text{KHz}$ (6dB bandwidth)	2400-2483.5	PASS

#### 5.1.1 TEST PROCEDURE

1. Set RBW= 100 kHz.
2. Set the video bandwidth (VBW)  $\geq 3 \times$  RBW.
3. Detector = Peak.
4. Trace mode = max hold.
5. Sweep = auto couple.
6. Allow the trace to stabilize.
7. Measure the maximum width of the emission that is constrained by the frequencies associated with the two outermost amplitude points (upper and lower) that are attenuated by 6 dB relative to the maximum level measured in the fundamental emission.

#### 5.1.2 DEVIATION FROM STANDARD

No deviation.

#### 5.1.3 TEST SETUP



#### 5.1.4 EUT OPERATION CONDITIONS

The EUT tested system was configured as the statements of 2.4 Unless otherwise a special operating condition is specified in the follows during the testing.

**5.1.5 TEST RESULTS**

EUT :	IP Camera	Model Name :	K2(703GC)
Temperature :	25 °C	Relative Humidity :	60%
Pressure :	1012 hPa	Test Voltage :	DC 5Vfrom adapter
Test Mode :	TX b Mode /CH01, CH06, CH11		

Channel	Frequency (MHz)	6dB bandwidth (MHz)	99% bandwidth (MHz)	Limit (kHz)	Result
Low	2412	10.08	/	500	Pass
Middle	2437	9.606	/	500	Pass
High	2462	9.144	/	500	Pass

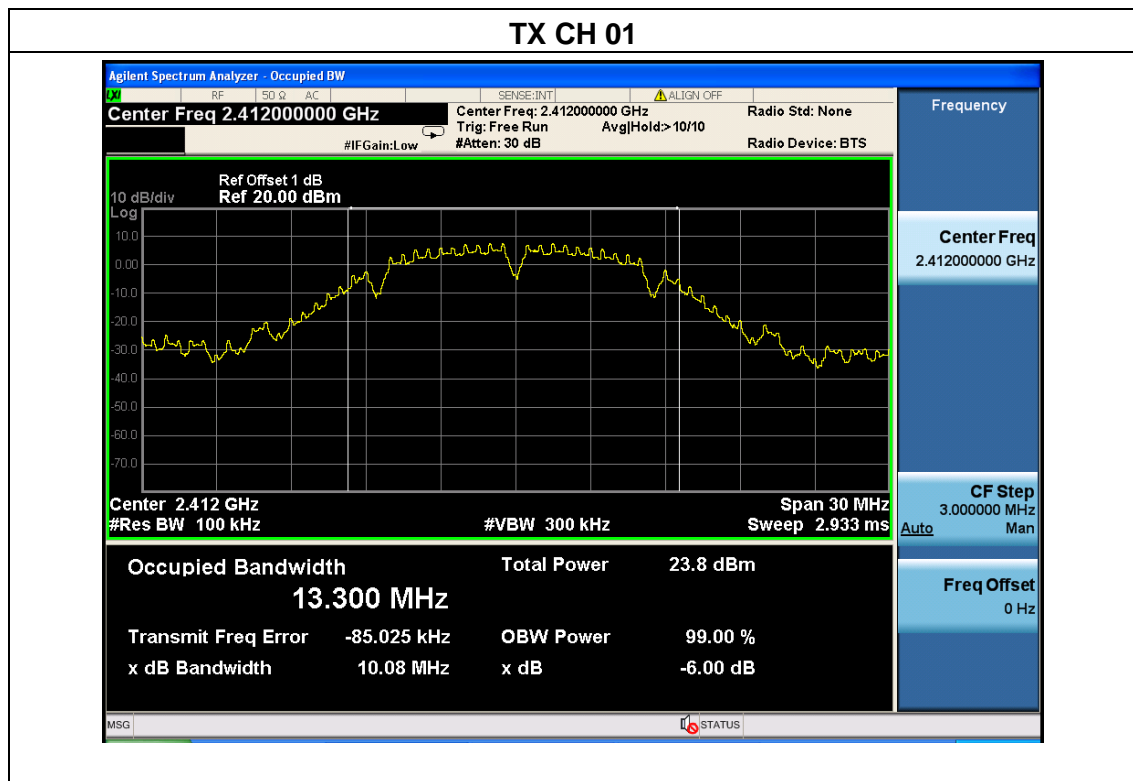

**TX CH 06**

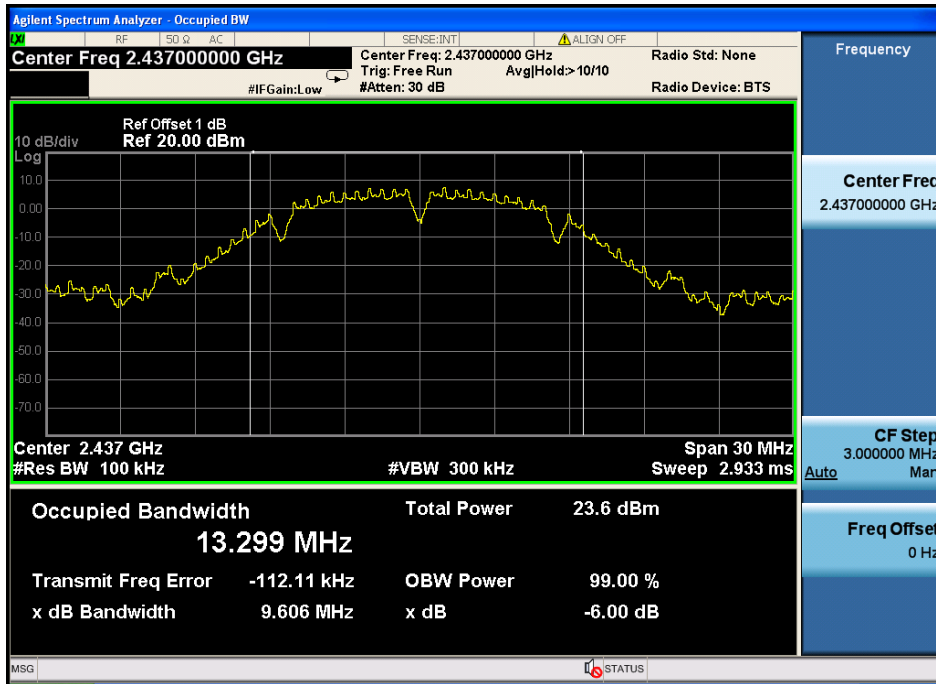

**TX CH 11**

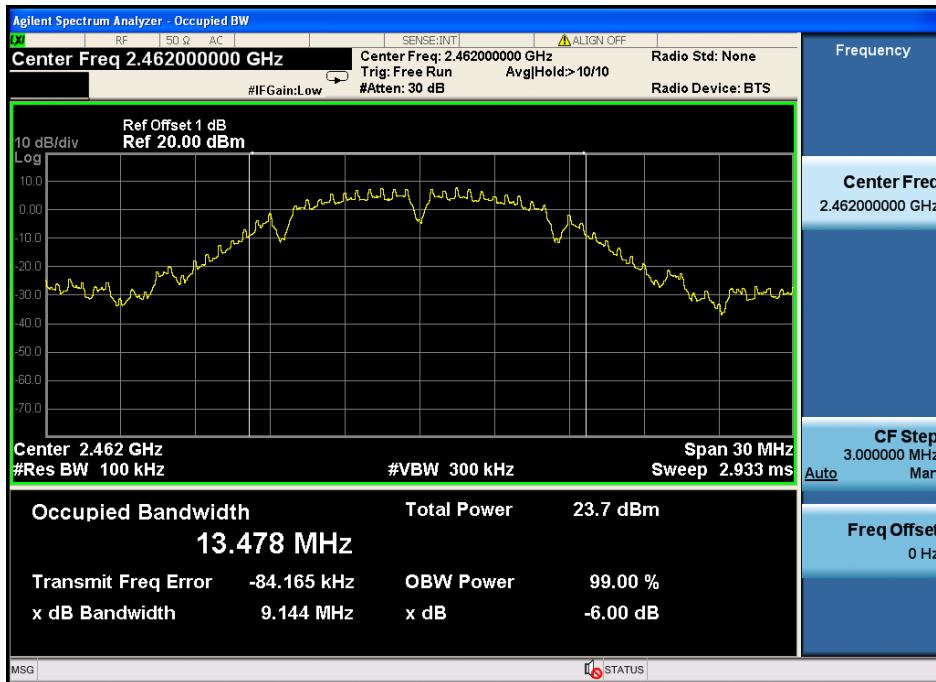

EUT :	IP Camera	Model Name :	K2(703GC)
Temperature :	25 °C	Relative Humidity :	60%
Pressure :	1012 hPa	Test Voltage :	DC 5Vfrom adapter
Test Mode :	TX g Mode /CH01, CH06, CH11		

Channel	Frequency (MHz)	6dB bandwidth (MHz)	99% bandwidth (MHz)	Limit (kHz)	Result
Low	2412	15.14	/	500	Pass
Middle	2437	15.66	/	500	Pass
High	2462	15.47	/	500	Pass

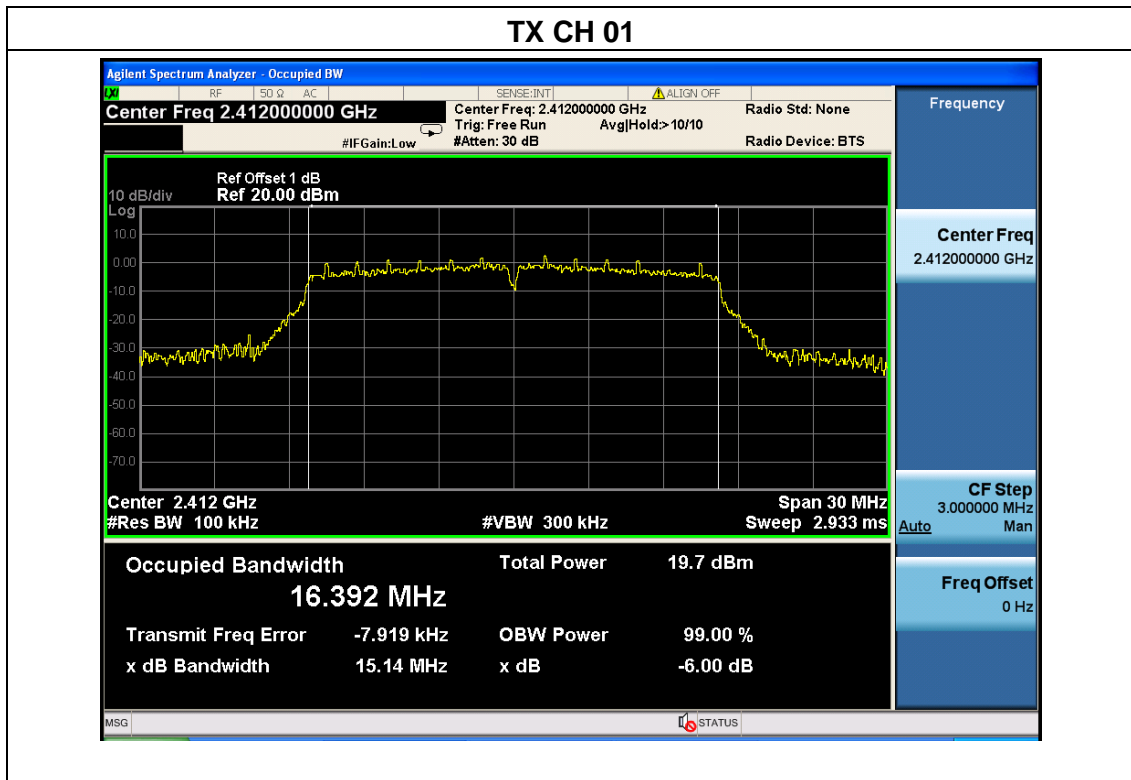

**TX CH 06**

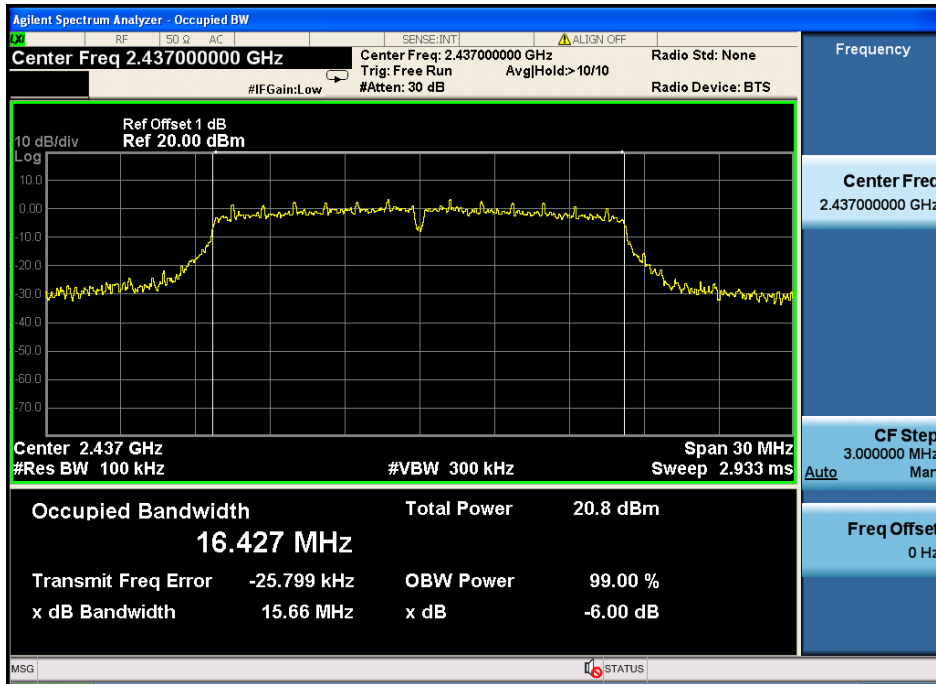

**TX CH 11**

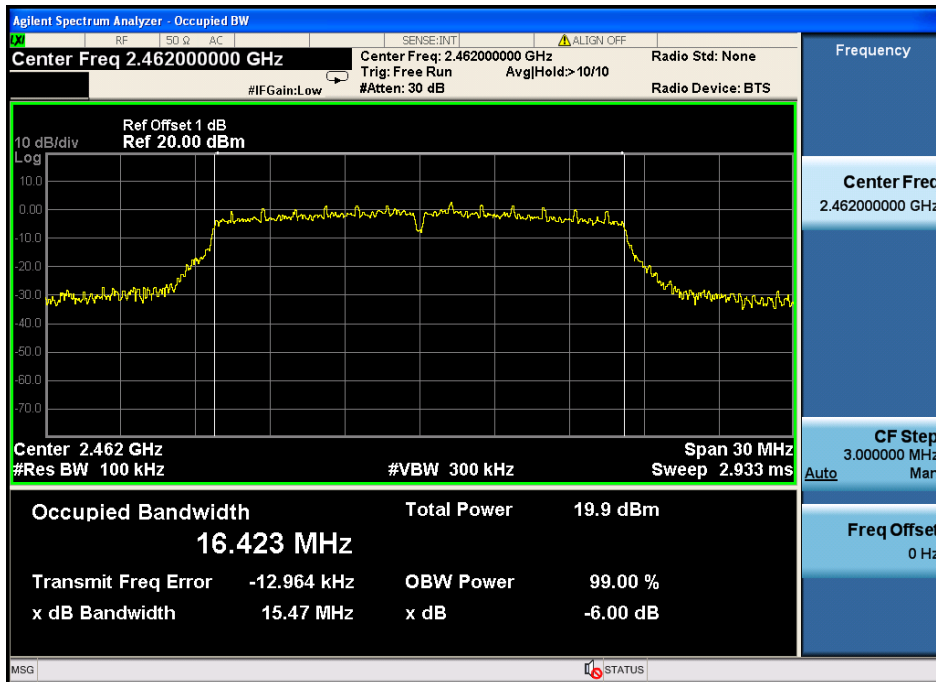

EUT :	IP Camera	Model Name :	K2(703GC)
Temperature :	25 °C	Relative Humidity :	60%
Pressure :	1012 hPa	Test Voltage :	DC 5Vfrom adapter
Test Mode :	TX n20 Mode /CH01, CH06, CH11		

Channel	Frequency (MHz)	6dB bandwidth (MHz)	99% bandwidth (MHz)	Limit (kHz)	Result
Low	2412	15.05	/	500	Pass
Middle	2437	15.16	/	500	Pass
High	2462	16.90	/	500	Pass

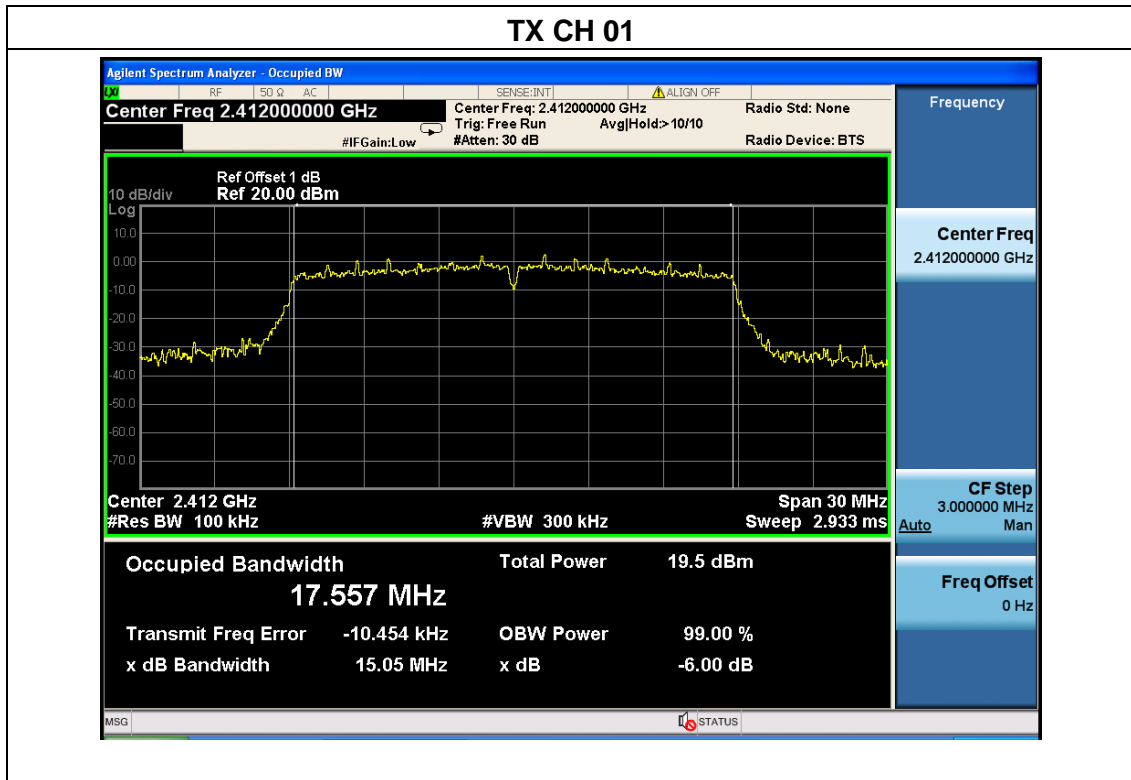

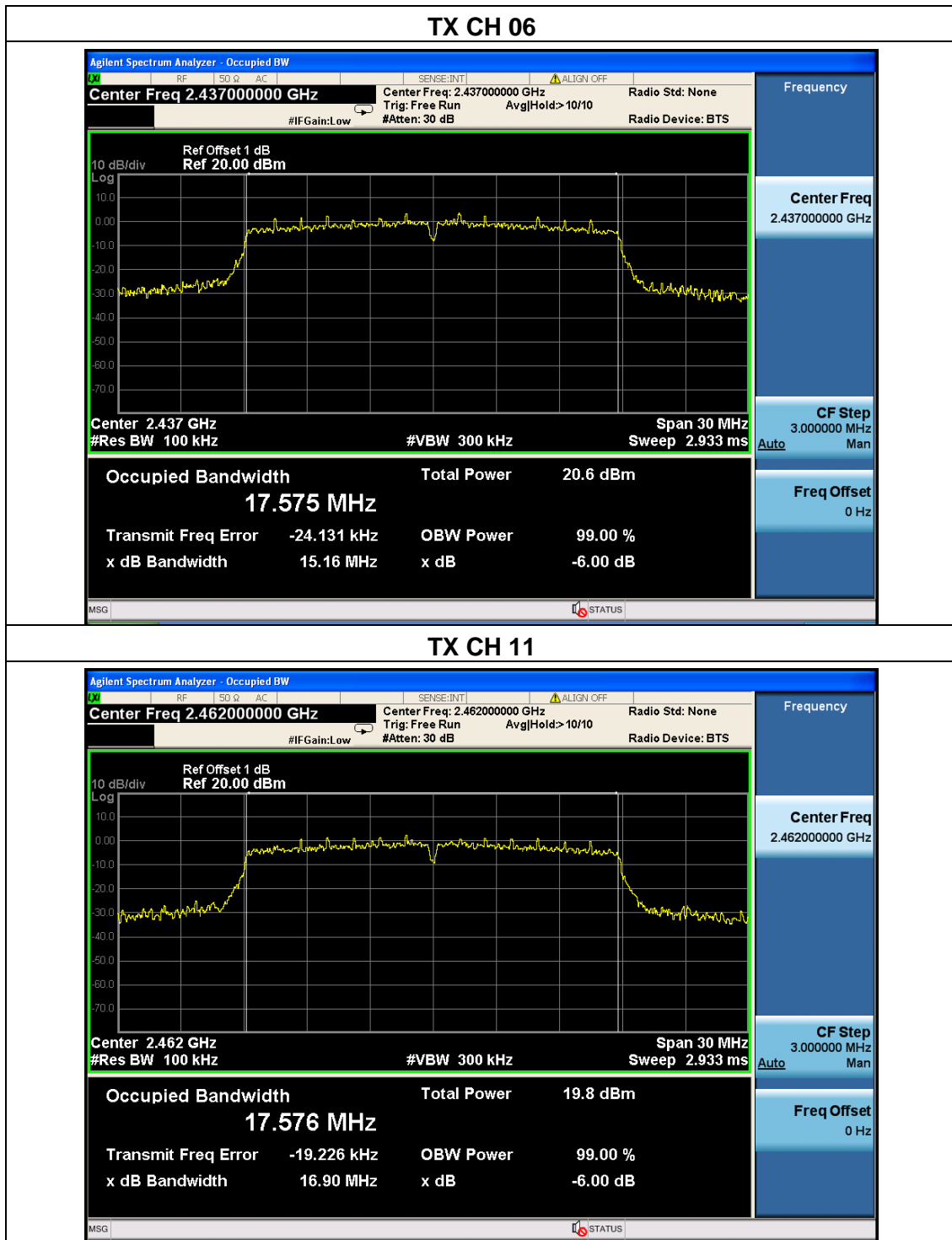



**6. PEAK OUTPUT POWER TEST**

**6.1 APPLIED PROCEDURES / LIMIT**

FCC Part15 (15.247) , Subpart C				
Section	Test Item	Limit	Frequency Range (MHz)	Result
15.247(b)(3)	Peak Output Power	1 watt or 30dBm	2400-2483.5	PASS

**6.1.1 TEST PROCEDURE**

- a. The EUT was directly connected to the Power meter

**6.1.2 DEVIATION FROM STANDARD**

No deviation.

**6.1.3 TEST SETUP**

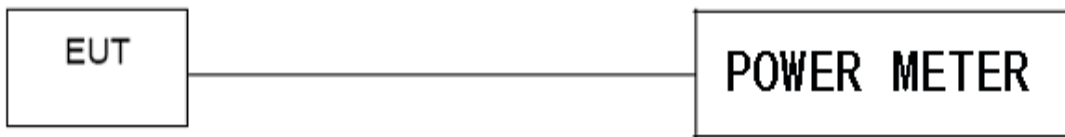

**6.1.4 EUT OPERATION CONDITIONS**

The EUT tested system was configured as the statements of 2.4 Unless otherwise a special operating condition is specified in the follows during the testing.

**6.1.5 TEST RESULTS**

EUT :	IP Camera	Model Name :	K2(703GC)
Temperature :	25 °C	Relative Humidity :	60%
Pressure :	1012 hPa	Test Voltage :	DC 5Vfrom adapter
Test Mode :	TX b/g/n Mode /CH01, CH06, CH11		

Test Channe	Frequency	Maximum Conducted Output Power(PK) (dBm)	LIMIT
	(MHz)	TX 802.11b Mode	dBm
CH01	2412	18.12	30
CH06	2437	18.35	30
CH11	2462	18.29	30
<b>TX 802.11g Mode</b>			
CH01	2412	16.56	30
CH06	2437	16.43	30
CH11	2462	16.61	30
<b>TX 802.11n20 Mode</b>			
CH01	2412	15.14	30
CH06	2437	15.24	30
CH11	2462	15.32	30

////

## 7. 100 KHZ BANDWIDTH OF FREQUENCY BAND EDGE

### APPLICABLE STANDARD

In any 100 kHz bandwidth outside the frequency band in which the spread spectrum or digitally modulated intentional radiator is operating, the radio frequency power that is produced by the intentional radiator shall be at least 20 dB below that in the 100 kHz bandwidth within the band that contains the highest level of the desired power, based on either an RF conducted or a radiated measurement, provided the transmitter demonstrates compliance with the peak conducted power limits. If the transmitter complies with the conducted power limits based on the use of RMS averaging over a time interval, as permitted under paragraph (b)(3) of this section, the attenuation required under this paragraph shall be 30 dB instead of 20 dB. Attenuation below the general limits specified in §15.209(a) is not required. In addition, radiated emissions which fall in the restricted bands, as defined in §15.205(a), must also comply with the radiated emission limits specified in §15.209(a) (see §15.205(c)).

### TEST PROCEDURE

- a) Check the calibration of the measuring instrument using either an internal calibrator or a known signal from an external generator.
- b) Position the EUT without connection to measurement instrument. Turn on the EUT and connect its antenna terminal to measurement instrument via a low loss cable. Then set it to any one measured frequency within its operating range, and make sure the instrument is operated in its linear range.
- c) Set RBW to 100 kHz and VBW of spectrum analyzer to 300 kHz with a convenient frequency span including 100 kHz bandwidth from band edge.
- d) Measure the highest amplitude appearing on spectral display and set it as a reference level. Plot the graph with marking the highest point and edge frequency.
- e) Repeat above procedures until all measured frequencies were complete.

### 7.1 DEVIATION FROM STANDARD

No deviation.

### 7.2 TEST SETUP



### 7.3 EUT OPERATION CONDITIONS

The EUT tested system was configured as the statements of 2.4 Unless otherwise a special operating condition is specified in the follows during the testing.

**7.4 TEST RESULTS**

EUT :	IP Camera	Model Name :	K2(703GC)
Temperature :	25 °C	Relative Humidity :	60%
Pressure :	1012 hPa	Test Voltage :	DC 5Vfrom adapter

Frequency Band	Delta Peak to band emission (dBc)	> Limit (dBc)	Result
802.11b mode			
Left-band	38.715	20	Pass
Right-band	58.798	20	Pass
802.11g mode			
Left-band	36.496	20	Pass
Right-band	40.503	20	Pass
802.11n20 mode			
Left-band	34.606	20	Pass
Right-band	40.231	20	Pass

802.11b: Band Edge, Left Side

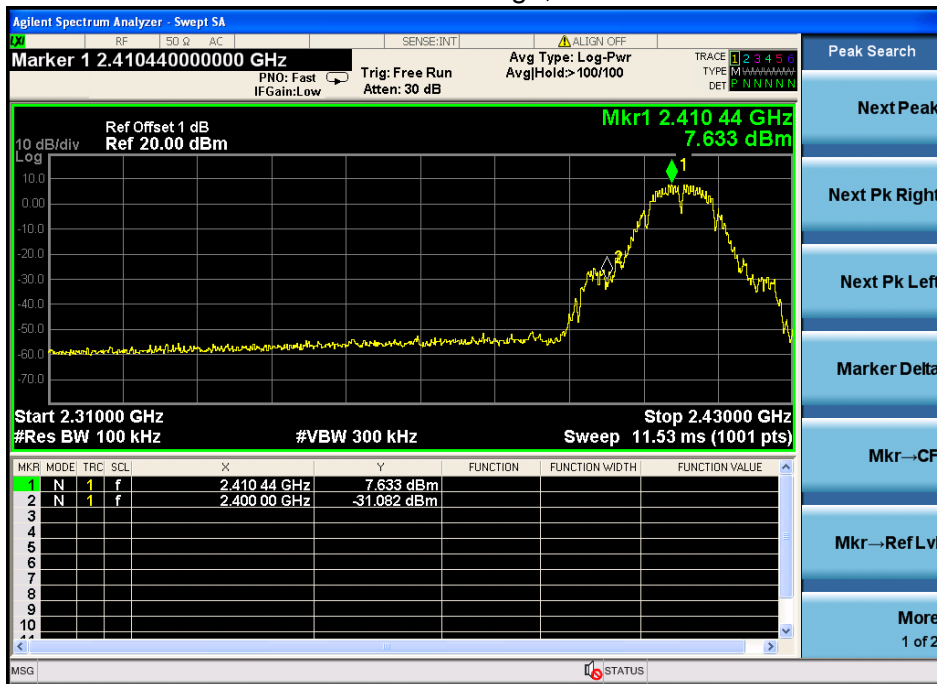

802.11b: Band Edge, Right Side



802.11g: Band Edge, Left Side



802.11g: Band Edge, Right Side

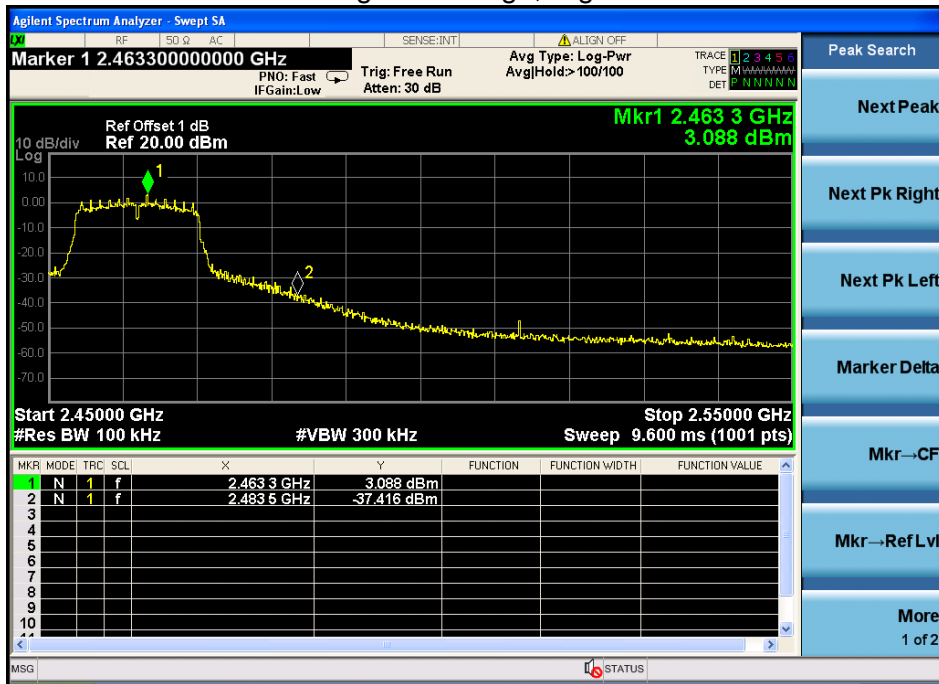

802.11n20: Band Edge, Left Side

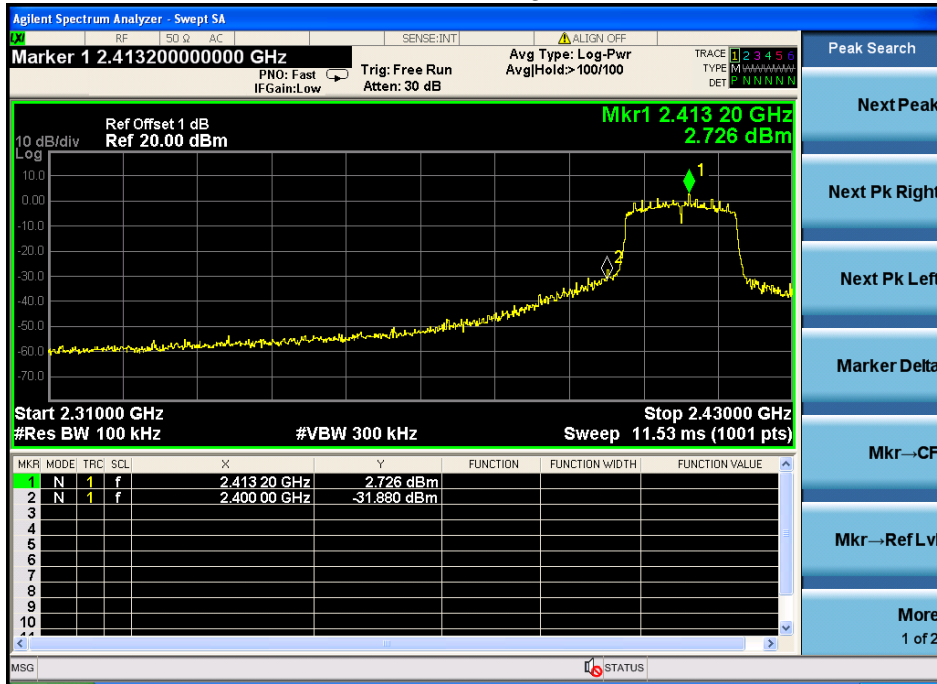

802.11n20: Band Edge, Right Side



## **8. ANTENNA REQUIREMENT**

### **8.1 STANDARD REQUIREMENT**

15.203 requirement: For intentional device, according to 15.203: an intentional radiator shall be designed to ensure that no antenna other than that furnished by the responsible party shall be used with the device.

### **8.2 EUT ANTENNA**

The EUT antenna is Chip antenna (Antenna Gain: 3.3dBi). It comply with the standard requirement. In case of replacement of broken antenna the same antenna type must be used.

**----END OF REPORT----**