

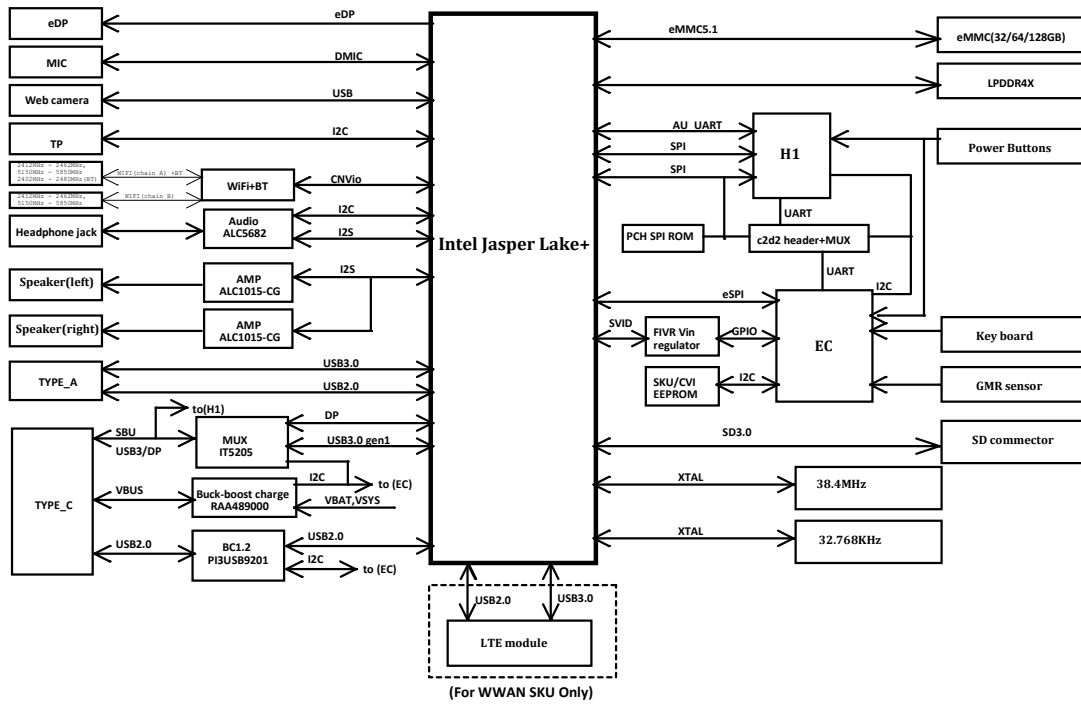

System Block Diagram





Contents

01_TABLE OF CONTENTS	26_SENSORS/MIPI/PEN/DMIC
02_SYSTEM BLOCK DIAGRAM	27_EDP
03_POWER TREE	28_WLAN
04_POWER SEQUENCING	29_EC
05_I2C MAP	30_Type A/SD
06_OTHER INFO	31_Type C
07_JSL-U42 (MEMORY)	32_USB C0: BATTERY CHARGER
08_JSL-U42 (DISPLAY/MIPI/I2C)	33_POWER: SOC RAILS 1
09_JSL-U42 (USB/PCIE)	34_POWER: SOC RAILS 2
10_JSL-U42 (CNV1/CLK/EMMC/HDA)	35_POWER: SOC RAILS 3
11_JSL-U42 (SPI/ESPI)	36_POWER: SYSTEM RAILS 1
12_JSL-U42 (PMU)	37_POWER: SYSTEM RAILS 2
13_JSL U42 (STRAPS)	38_POWER: LDOs/LOAD SWITCHES
14_JSL-U42 (CPU AND PCH POWER)	39_SUB-BOARD CONNECTORS
15_JSL-U42 (POWER DECOUPLING)	40_HOLE&BOSS
16_JSL-U42 (VSS)	41_BLANK
17_JSL-U42 (MIPI60/DEBUG)	42_Right IO board_LTE
18_LPDDR4 (CHA+B)	43_BLANK
19_LPDDR4 (CHC+D)	44_Right IO board_USB3.0
20_WP/CBI EEPROM/SPI ROM	45_Right IO board_Type C
21_H1	46_Right IO board_Charger
22_C2D2	47_Right IO board_POWER
23_STORAGE_EMMC	48_Right IO board_CONN
24_AUDIO	49_P_SENSOR
25_KB/TP/KBL/LED/BTNs/PEN	

 Huaqin Telecom Technology Co., Ltd.	
Page name: COVER PAGE	
Size: A4	Project Name: JSL
Date: Wednesday, July 14, 2021	REV: V1.0
Sheet: 1 of 47	

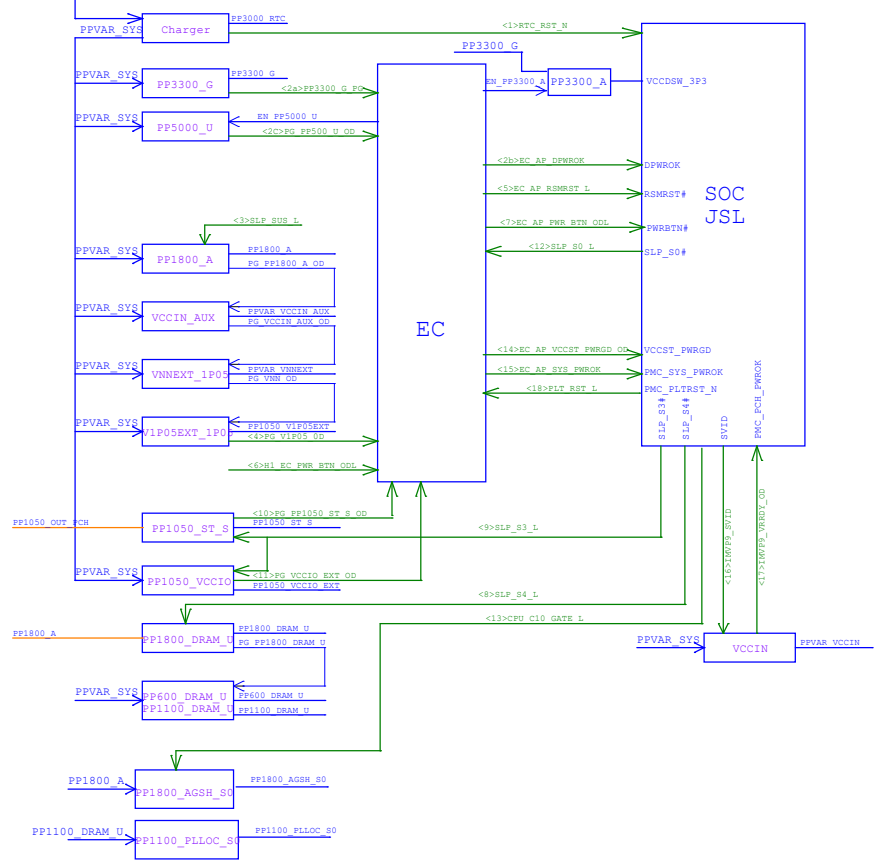
Battery&Adapter



 HUAQIN 华勤通讯		Huaqin Telecom Technology Com.,Ltd.	
Page name: COVER PAGE			
Size: A4	Project Name: JSL	REV: V1.0	
Date: Wednesday, July 14, 2021		Sheet: 5	of 47

5

4

3

2

1

D

D

C

C

B

B

A

A

5

4

3

2

1

 HUAQIN 华勤通讯		Huaqin Telecom Technology Com.,Ltd.	
Page name: COVER PAGE			
Size: A4	Project Name: JSL	REV: V1.0	
Date: Wednesday, July 14, 2021		Sheet: 6	of 47

CHA+B

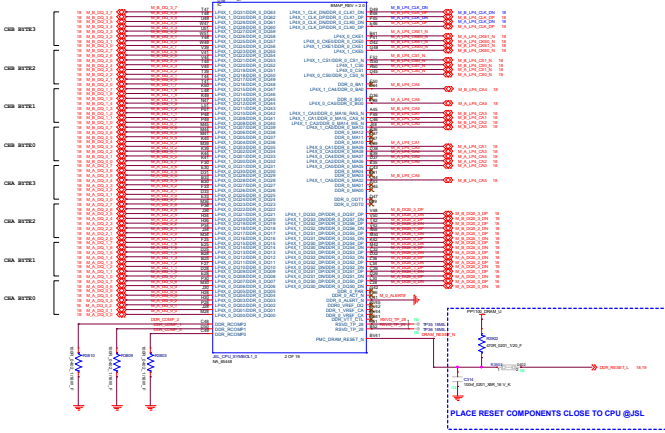

CHC+D

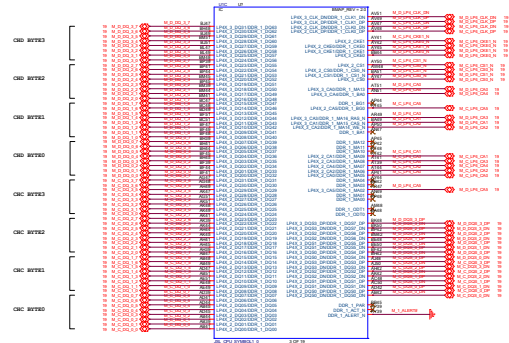

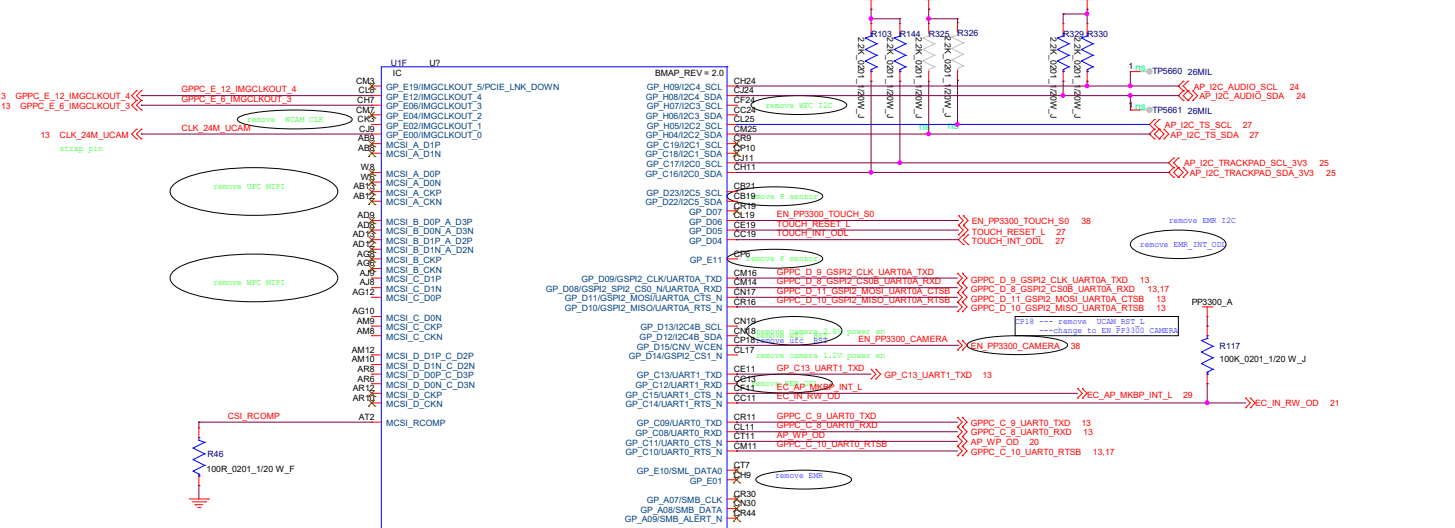
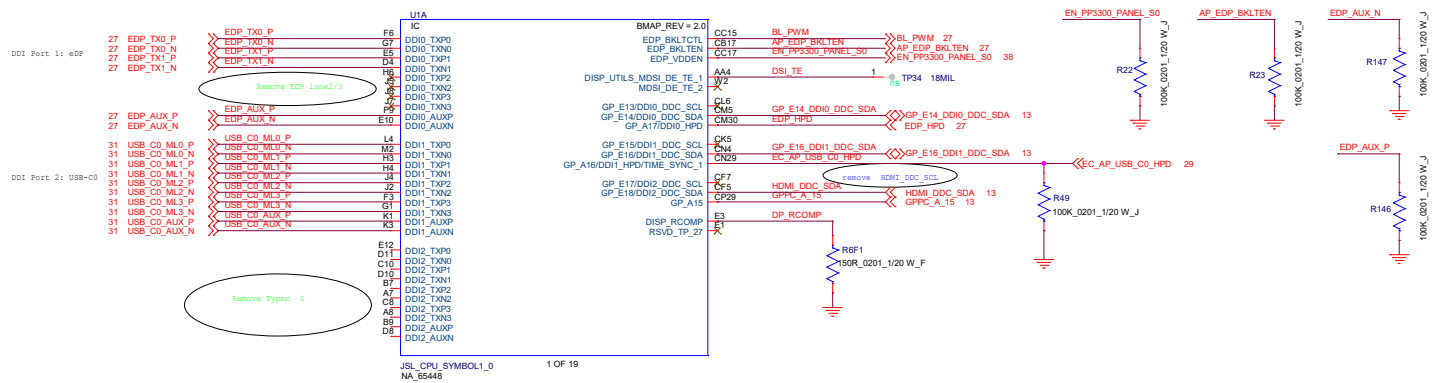

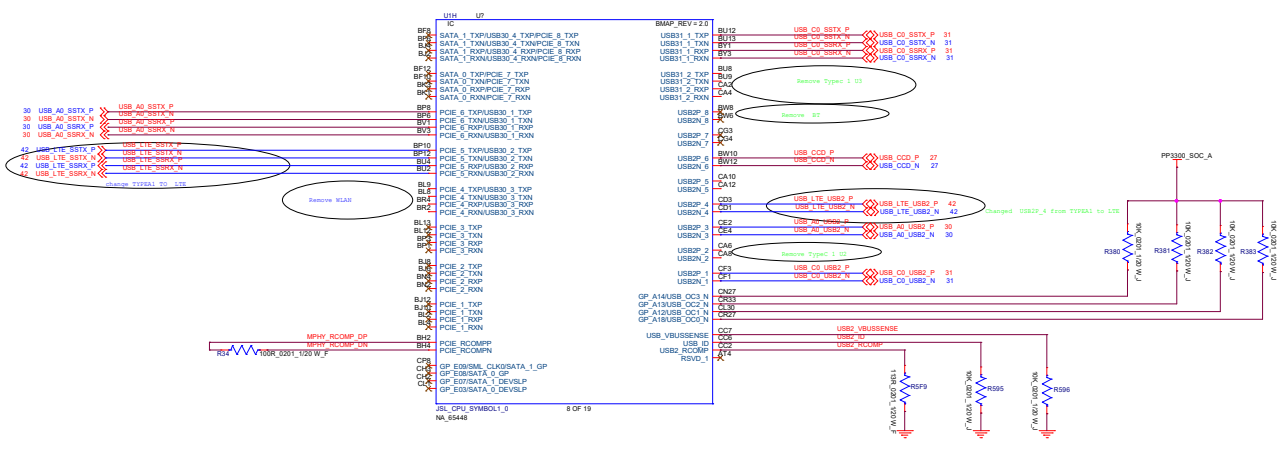

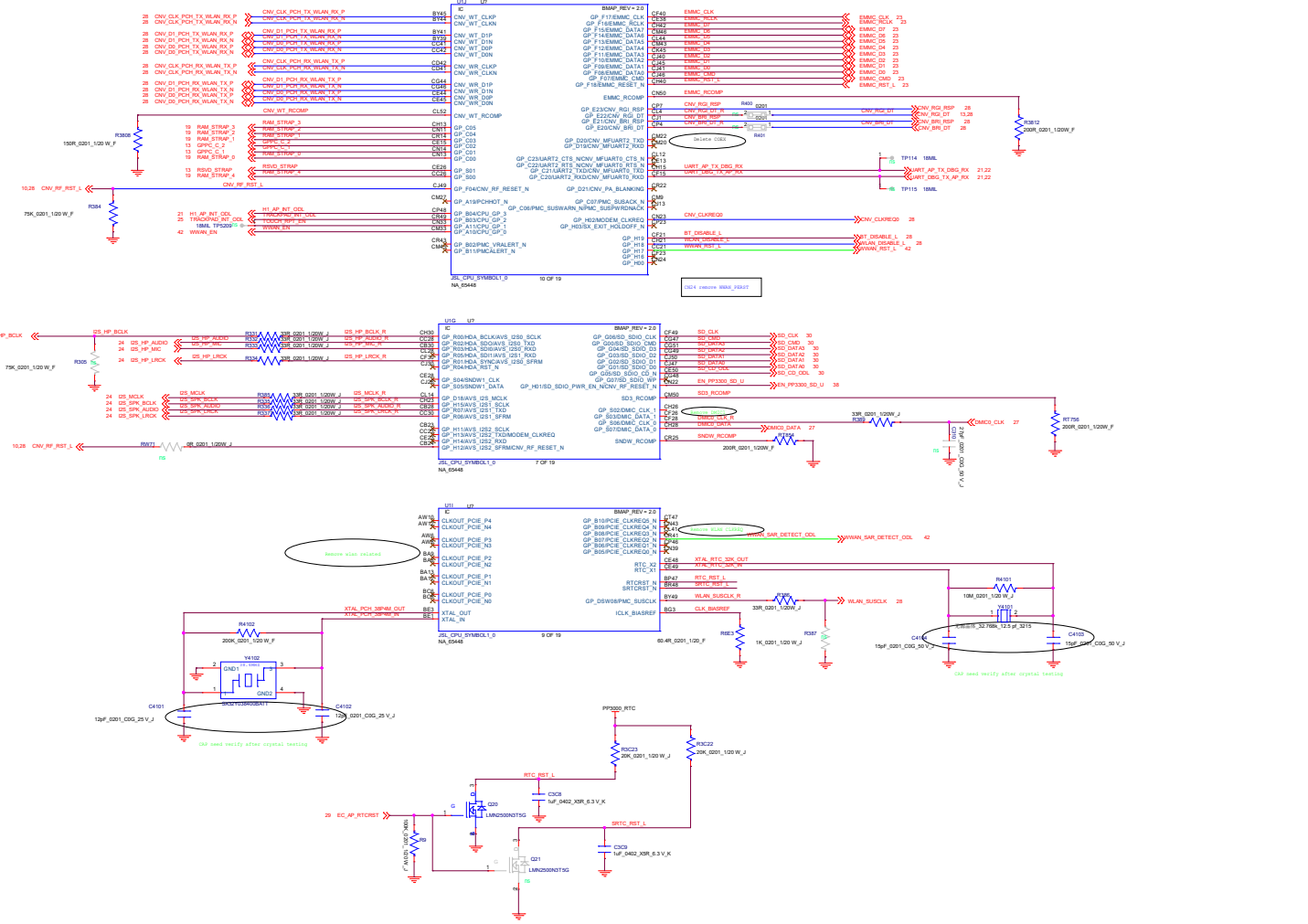

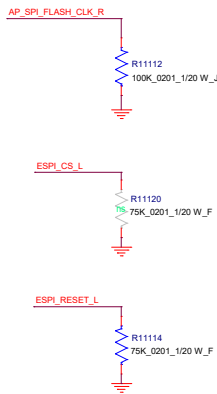
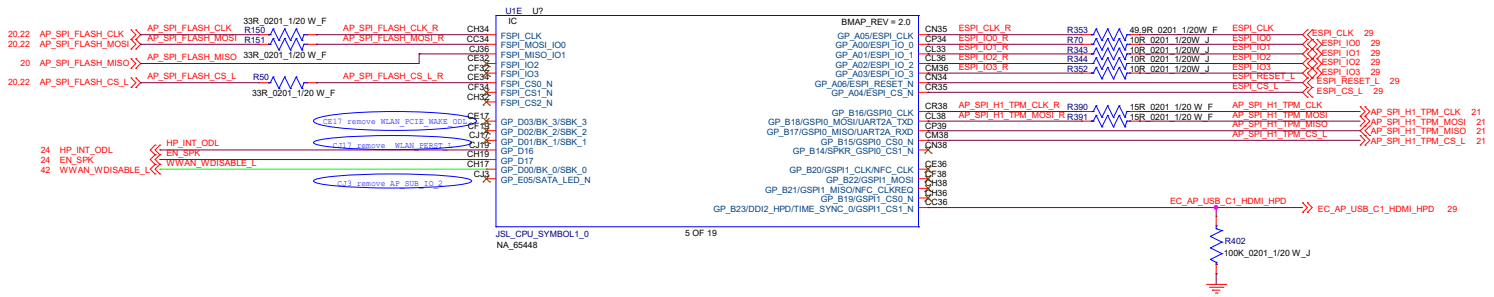

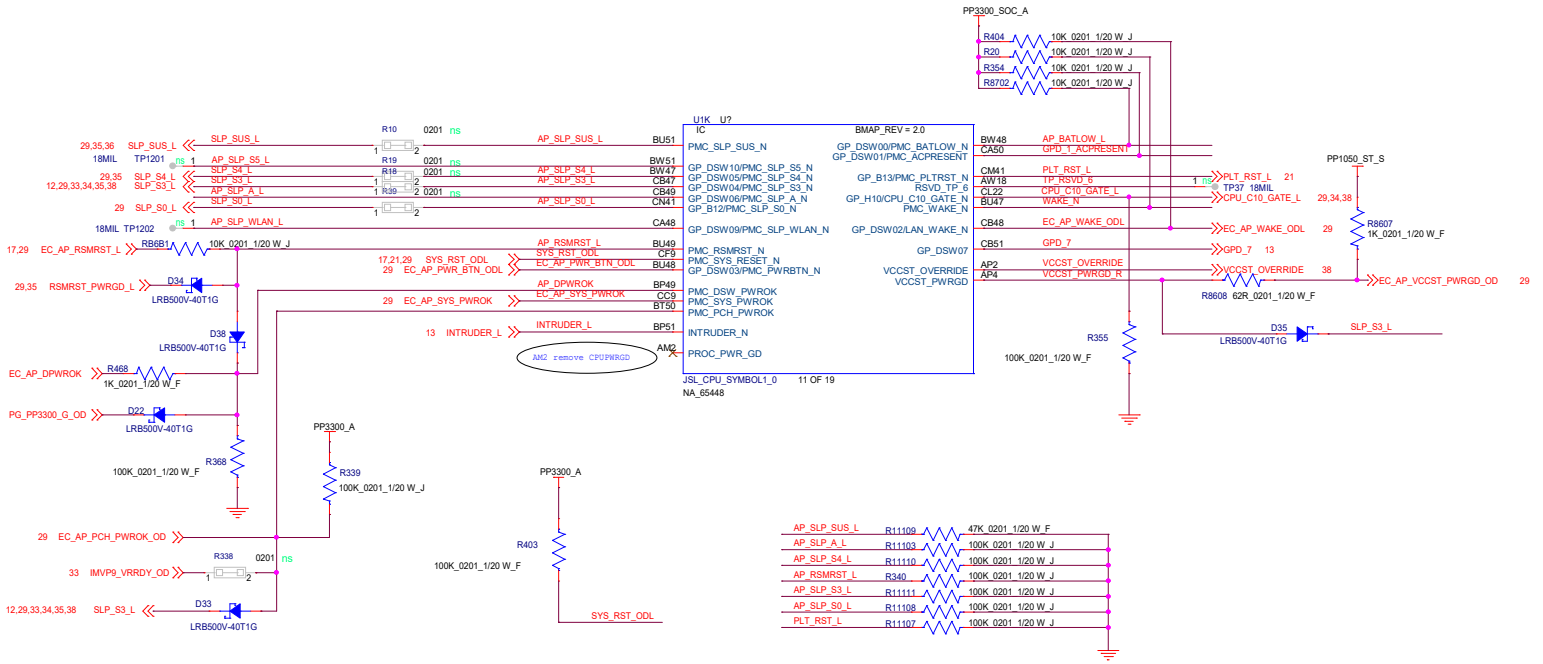

- AP_SLP_SUS_L R11108 47K_0201_120_W_F
- AP_SLP_A_L R11103 100K_0201_120_W_J
- AP_SLP_S4_L R11110 100K_0201_120_W_J
- AP_RSMRST_L R340 100K_0201_120_W_J
- AP_SLP_S3_L R11111 100K_0201_120_W_J
- AP_SLP_S0_L R11108 100K_0201_120_W_J
- PLT_RST_L R11107 100K_0201_120_W_J

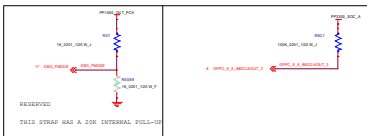
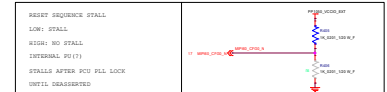
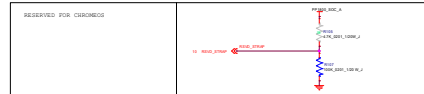
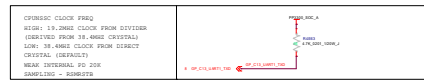
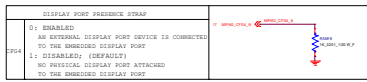

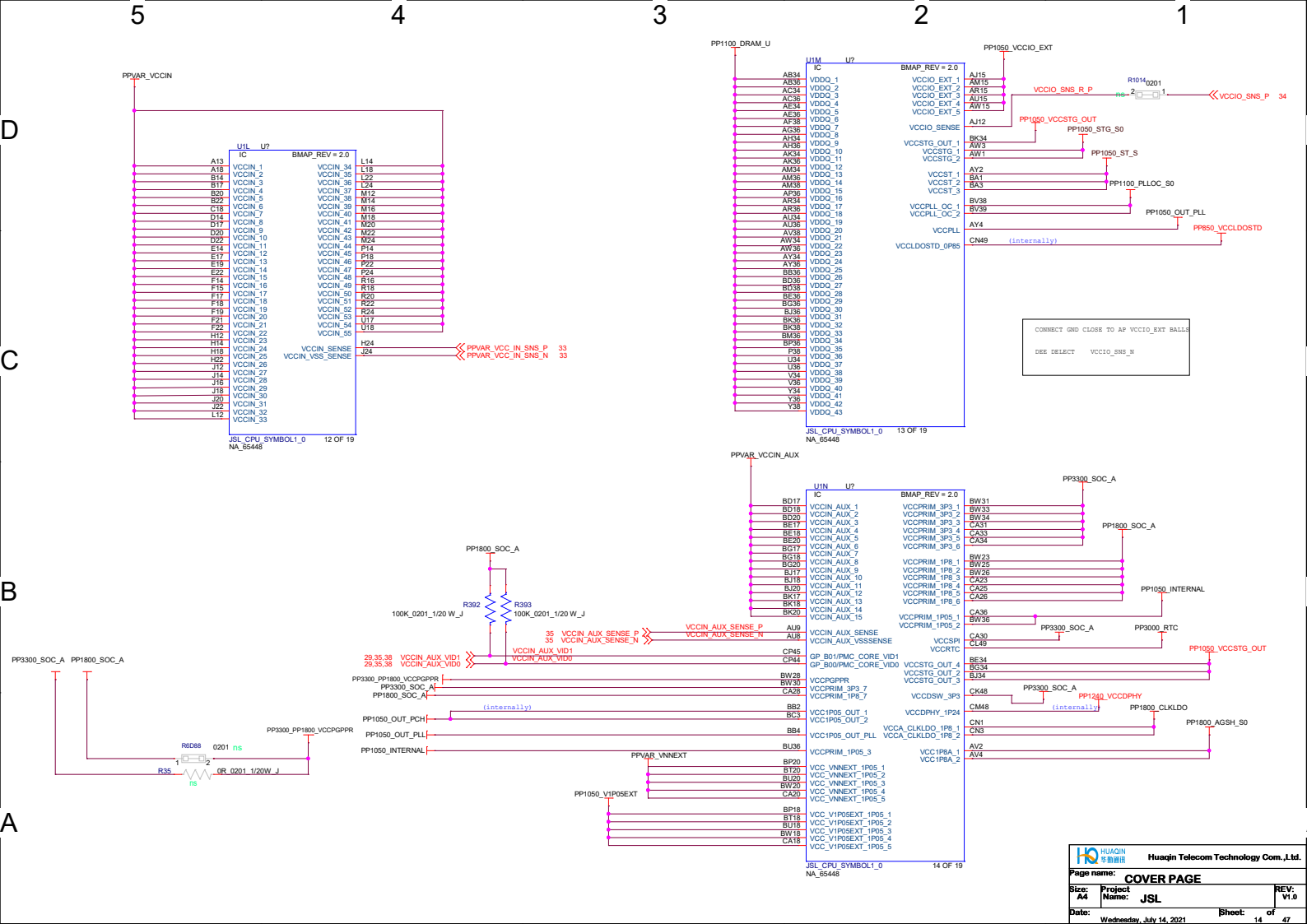

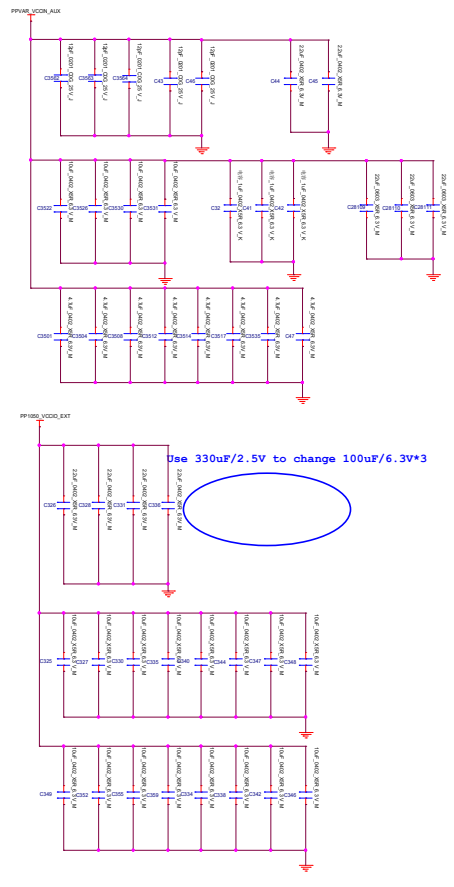
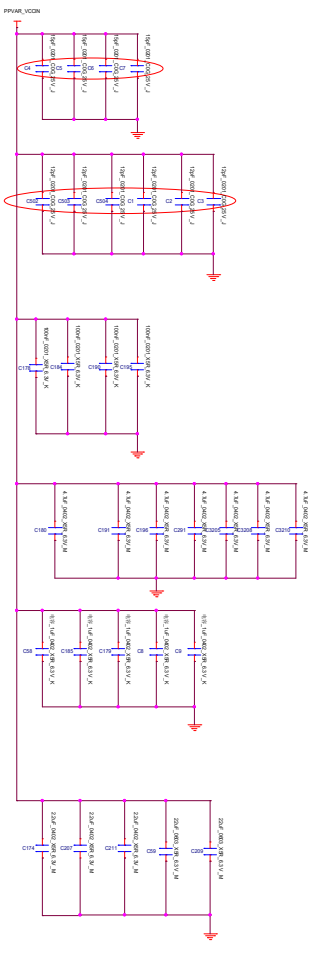
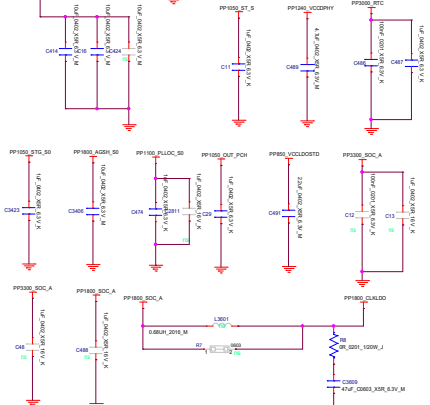
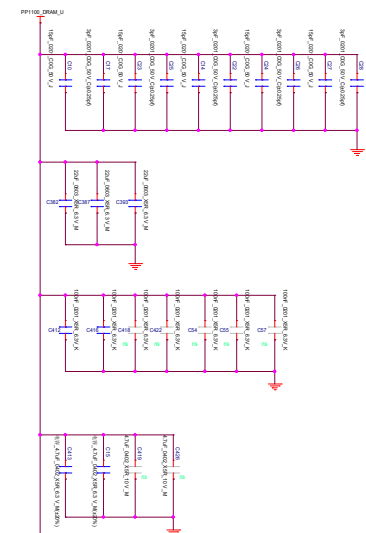

UJP U7_BMAP_REV# 2.0
VSS_1 VSS_10 AA59
VSS_2 VSS_11 AA52
VSS_3 VSS_12 AA47
VSS_4 VSS_13 AA42
VSS_5 VSS_14 AA37
VSS_6 VSS_15 AA32
VSS_7 VSS_16 AA27
VSS_8 VSS_17 AA22
VSS_9 VSS_18 AA17
VSS_10 VSS_19 AA12
VSS_11 VSS_20 AA07
VSS_12 VSS_21 AA02
VSS_13 VSS_22 AA99
VSS_14 VSS_23 AA94
VSS_15 VSS_24 AA89
VSS_16 VSS_25 AA84
VSS_17 VSS_26 AA79
VSS_18 VSS_27 AA74
VSS_19 VSS_28 AA69
VSS_20 VSS_29 AA64
VSS_21 VSS_30 AA59
VSS_22 VSS_31 AA54
VSS_23 VSS_32 AA49
VSS_24 VSS_33 AA44
VSS_25 VSS_34 AA39
VSS_26 VSS_35 AA34
VSS_27 VSS_36 AA29
VSS_28 VSS_37 AA24
VSS_29 VSS_38 AA19
VSS_30 VSS_39 AA14
VSS_31 VSS_40 AA09
VSS_32 VSS_41 AA04
VSS_33 VSS_42 AA99
VSS_34 VSS_43 AA94
VSS_35 VSS_44 AA89
VSS_36 VSS_45 AA84
VSS_37 VSS_46 AA79
VSS_38 VSS_47 AA74
VSS_39 VSS_48 AA69
VSS_40 VSS_49 AA64
VSS_41 VSS_50 AA59
VSS_42 VSS_51 AA54
VSS_43 VSS_52 AA49
VSS_44 VSS_53 AA44
VSS_45 VSS_54 AA39
VSS_46 VSS_55 AA34
VSS_47 VSS_56 AA29
VSS_48 VSS_57 AA24
VSS_49 VSS_58 AA19
VSS_50 VSS_59 AA14
VSS_51 VSS_60 AA09
VSS_52 VSS_61 AA04
VSS_53 VSS_62 AA99
VSS_54 VSS_63 AA94
VSS_55 VSS_64 AA89
VSS_56 VSS_65 AA84
VSS_57 VSS_66 AA79
VSS_58 VSS_67 AA74
VSS_59 VSS_68 AA69
VSS_60 VSS_69 AA64
VSS_61 VSS_70 AA59
VSS_62 VSS_71 AA54
VSS_63 VSS_72 AA49
VSS_64 VSS_73 AA44
VSS_65 VSS_74 AA39
VSS_66 VSS_75 AA34
VSS_67 VSS_76 AA29
VSS_68 VSS_77 AA24
VSS_69 VSS_78 AA19
VSS_70 VSS_79 AA14
VSS_71 VSS_80 AA09
VSS_72 VSS_81 AA04
VSS_73 VSS_82 AA99
VSS_74 VSS_83 AA94
VSS_75 VSS_84 AA89
VSS_76 VSS_85 AA84
VSS_77 VSS_86 AA79
VSS_78 VSS_87 AA74
VSS_79 VSS_88 AA69
VSS_80 VSS_89 AA64
VSS_81 VSS_90 AA59
VSS_82 VSS_91 AA54
VSS_83 VSS_92 AA49
VSS_84 VSS_93 AA44
VSS_85 VSS_94 AA39
VSS_86 VSS_95 AA34
VSS_87 VSS_96 AA29
VSS_88 VSS_97 AA24
VSS_89 VSS_98 AA19
VSS_90 VSS_99 AA14
VSS_91 VSS_100 AA09

UIR U7_BMAP_REV# 2.0
V44 VSS_445 VSS_378 L6
V45 VSS_444 VSS_377 L5
V46 VSS_443 VSS_376 L4
V47 VSS_442 VSS_375 L3
V48 VSS_441 VSS_374 L2
V49 VSS_440 VSS_373 L1
V50 VSS_439 VSS_372 K5
V51 VSS_438 VSS_371 K4
V52 VSS_437 VSS_369 K3
V53 VSS_436 VSS_368 K2
V54 VSS_435 VSS_367 K1
V55 VSS_434 VSS_366 J10
V56 VSS_433 VSS_365 J9
V57 VSS_432 VSS_364 J8
V58 VSS_431 VSS_363 J7
V59 VSS_430 VSS_362 J6
V60 VSS_429 VSS_361 J5
V61 VSS_428 VSS_360 J4
V62 VSS_427 VSS_359 J3
V63 VSS_426 VSS_358 J2
V64 VSS_425 VSS_357 J1
V65 VSS_424 VSS_356 H5
V66 VSS_423 VSS_355 H4
V67 VSS_422 VSS_354 H3
V68 VSS_421 VSS_353 H2
V69 VSS_420 VSS_352 H1
V70 VSS_419 VSS_351 G5
V71 VSS_418 VSS_350 G4
V72 VSS_417 VSS_349 G3
V73 VSS_416 VSS_348 G2
V74 VSS_415 VSS_347 G1
V75 VSS_414 VSS_346 F4
V76 VSS_413 VSS_345 F3
V77 VSS_412 VSS_344 F2
V78 VSS_411 VSS_343 F1
V79 VSS_410 VSS_342 E5
V80 VSS_409 VSS_341 E4
V81 VSS_408 VSS_340 E3
V82 VSS_407 VSS_339 E2
V83 VSS_406 VSS_338 E1
V84 VSS_405 VSS_337 D12
V85 VSS_404 VSS_336 D11
V86 VSS_403 VSS_335 D10
V87 VSS_402 VSS_334 D9
V88 VSS_401 VSS_333 D8
V89 VSS_400 VSS_332 D7
V90 VSS_399 VSS_331 D6
V91 VSS_398 VSS_330 D5
V92 VSS_397 VSS_329 D4
V93 VSS_396 VSS_328 D3
V94 VSS_395 VSS_327 D2
V95 VSS_394 VSS_326 D1
V96 VSS_393 VSS_325 C145
V97 VSS_392 VSS_324 C142
V98 VSS_391 VSS_323 C141
V99 VSS_390 VSS_322 C139
V100 VSS_389 VSS_321 C137
V101 VSS_388 VSS_320 C134
V102 VSS_387 VSS_319 C132
V103 VSS_386 VSS_318 C128
V104 VSS_385 VSS_317 C126
V105 VSS_384 VSS_316 C125
V106 VSS_383 VSS_315 C124
V107 VSS_382 VSS_314 C118
V108 VSS_381 VSS_313 C115
V109 VSS_380 VSS_312 CR50
V110 VSS_379 VSS_311 CR1

UIO U7_BMAP_REV# 2.0
B33 VSS_159 VSS_224 BU33
B34 VSS_160 VSS_225 BU6
B35 VSS_161 VSS_226 BU7
B36 VSS_162 VSS_227 BU47
B37 VSS_163 VSS_228 BU52
B38 VSS_164 VSS_229 BU13
B39 VSS_165 VSS_230 BU17
B40 VSS_166 VSS_231 BU2
B41 VSS_167 VSS_232 BU2
B42 VSS_168 VSS_233 BU4
B43 VSS_169 VSS_234 BU9
B44 VSS_170 VSS_235 BU42
B45 VSS_171 VSS_236 C13
B46 VSS_172 VSS_237 C16
B47 VSS_173 VSS_238 C21
B48 VSS_174 VSS_239 C28
B49 VSS_175 VSS_240 C29
B50 VSS_176 VSS_241 C34
B51 VSS_177 VSS_242 C40
B52 VSS_178 VSS_243 C50
B53 VSS_179 VSS_244 CA17
B54 VSS_180 VSS_245 CA21
B55 VSS_181 VSS_246 CA27
B56 VSS_182 VSS_247 CA52
B57 VSS_183 VSS_248 CA9
B58 VSS_184 VSS_249 C61
B59 VSS_185 VSS_250 CB26
B60 VSS_186 VSS_251 CB32
B61 VSS_187 VSS_252 CB3
B62 VSS_188 VSS_253 CB34
B63 VSS_189 VSS_254 CB36
B64 VSS_190 VSS_255 CB32
B65 VSS_191 VSS_256 CB39
B66 VSS_192 VSS_257 CB44
B67 VSS_193 VSS_258 CC45
B68 VSS_194 VSS_259 CC47
B69 VSS_195 VSS_260 CC50
B70 VSS_196 VSS_261 CC52
B71 VSS_197 VSS_262 CC52
B72 VSS_198 VSS_263 CC6
B73 VSS_199 VSS_264 CC7
B74 VSS_200 VSS_265 CE21
B75 VSS_201 VSS_266 CE24
B76 VSS_202 VSS_267 CE24
B77 VSS_203 VSS_268 CE47
B78 VSS_204 VSS_269 CE5
B79 VSS_205 VSS_270 CF13
B80 VSS_206 VSS_271 CF17
B81 VSS_207 VSS_272 CF18
B82 VSS_208 VSS_273 CF42
B83 VSS_209 VSS_274 CF52
B84 VSS_210 VSS_275 CF1
B85 VSS_211 VSS_276 CF15
B86 VSS_212 VSS_277 CH43
B87 VSS_213 VSS_278 C121
B88 VSS_214 VSS_279 C123
B89 VSS_215 VSS_280 C128
B90 VSS_216 VSS_281 C132
B91 VSS_217 VSS_282 C132
B92 VSS_218 VSS_283 C138
B93 VSS_219 VSS_284 C138
B94 VSS_220 VSS_285 C138
B95 VSS_221 VSS_285 C138
B96 VSS_222 VSS_285 C138
B97 VSS_223 VSS_285 C138
B98 VSS_224 VSS_285 C138
B99 VSS_225 VSS_285 C138
B100 VSS_226 VSS_285 C138

UIO U7_BMAP_REV# 2.0
IST_TP_1 AY17 TP_IST_1 1 ns TP12 18MIL
IST_TP_0 AW17 TP_IST_0 1 ns TP13 18MIL
IST_TRIG_0 AV16
IS1_TRIG_0 AV17
RSVD_2 AM17
RSVD_3 AM17
RSVD_4 AC18 TP_RSVD_17 1 ns TP14 18MIL
RSVD_TP_17 AC17 TP_RSVD_16 1 ns TP15 18MIL
RSVD_TP_16 AR33 TP_RSVD_18 1 ns TP16 18MIL
RSVD_TP_18 V31 TP_RSVD_20 1 ns TP17 18MIL
RSVD_TP_19 D31 TP_RSVD_19 1 ns TP18 18MIL
RSVD_TP_20 AS4 TP_RSVD_22 1 ns TP19 18MIL
RSVD_TP_22 AM33 TP_RSVD_21 1 ns TP20 18MIL
RSVD_TP_21 V25 TP_RSVD_24 1 ns TP21 18MIL
RSVD_TP_24 V23 TP_RSVD_23 1 ns TP22 18MIL
RSVD_TP_23
RSVD_19 U15
RSVD_TP_14 AK17 TP_RSVD_14 1 ns TP23 18MIL
RSVD_TP_15 U33 TP_RSVD_15 1 ns TP24 18MIL
RSVD_20 W12
RSVD_TP_17 W15
RSVD_TP_18 W15
RSVD_TP_19 W15 TP_PCH_IST_1 1 ns TP25 18MIL
PCH_IST_TP_0 BK33 TP_PCH_IST_0 1 ns TP26 18MIL
RSVD_TP_13
RSVD_TP_12 BV38
RSVD_TP_11 BV15 TP_RSVD_11 1 ns TP27 18MIL
RSVD_TP_10 BV15 TP_RSVD_10 1 ns TP28 18MIL
RSVD_TP_12 AG33 TP_RSVD_12 1 ns TP29 18MIL
RSVD_TP_12 BT34 TP_RSVD_13 1 ns TP30 18MIL
RSVD_TP_13
RSVD_TP_13 BP34 TP_RSVD_7 1 ns TP31 18MIL
RSVD_TP_8 BM34 TP_RSVD_8 1 ns TP32 18MIL
RSVD_TP_9 BT56 TP_RSVD_9 1 ns TP33 18MIL

18 OF 19
JSL_CPU_SYMBOL1_0
NA_65448

18 OF 19
JSL_CPU_SYMBOL1_0
NA_65448

1 OF 19
JSL_CPU_SYMBOL1_0
NA_65448

15 OF 19
JSL_CPU_SYMBOL1_0
NA_65448

HUAQIN 华勤通信
Huaqin Telecom Technology Com., Ltd.
Page name: COVER PAGE
Size: A4 Project Name: JSL REV: V1.0
Date: Wednesday, July 14, 2021 Sheet: 16 of 47

CHA

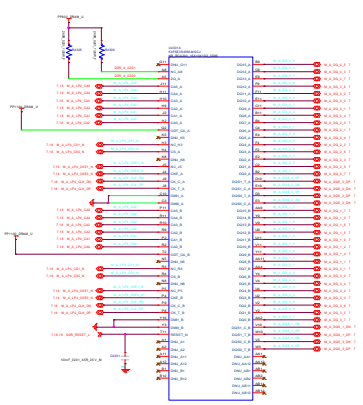
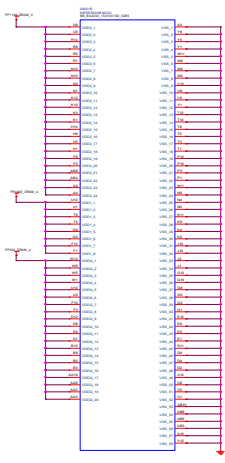

CHB

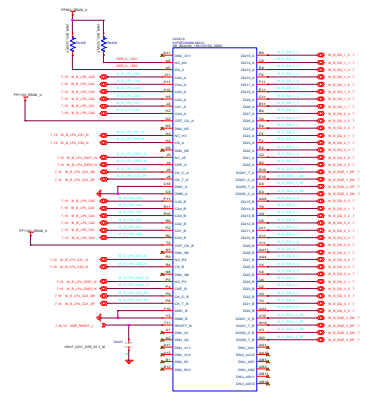

DISTRIBUTE EVENLY, 1 FOR EACH DRAM

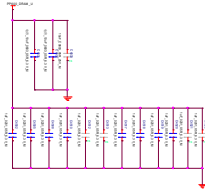

EMC CARS - PLACE <4MM FROM MEMORY VDD0, WITH EACH PAIR <12MM APART



DISTRIBUTE EVENLY FOR EACH DRAM

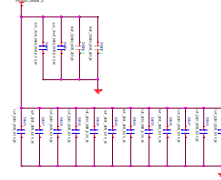

DISTRIBUTE EVENLY, 6 FOR EACH DRAM

DISTRIBUTE EVENLY FOR EACH DRAM

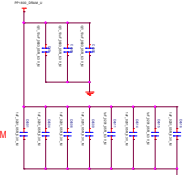

DISTRIBUTE EVENLY, 4 FOR EACH DRAM

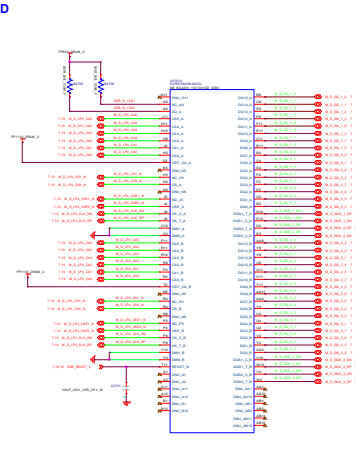
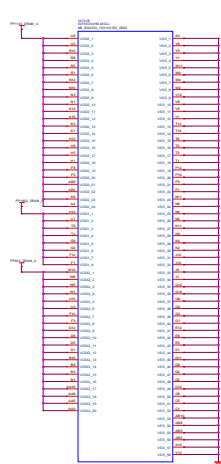
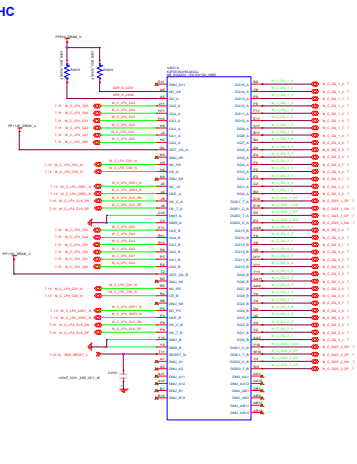
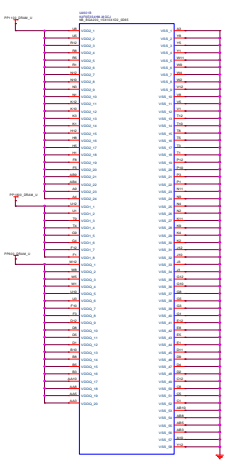

DISTRIBUTE EVENLY, 1 FOR EACH DRAM

DISTRIBUTE EVENLY, 4 FOR EACH DRAM

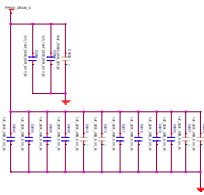

DISTRIBUTE EVENLY FOR EACH DRAM

DISTRIBUTE EVENLY, 6 FOR EACH DRAM

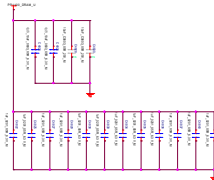

DISTRIBUTE EVENLY FOR EACH DRAM

DISTRIBUTE EVENLY, 4 FOR EACH DRAM

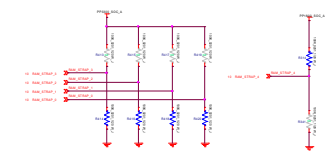
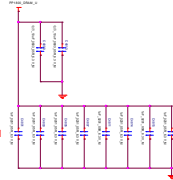

10_20 change to GT34C02B
check footprint

CBI ROM

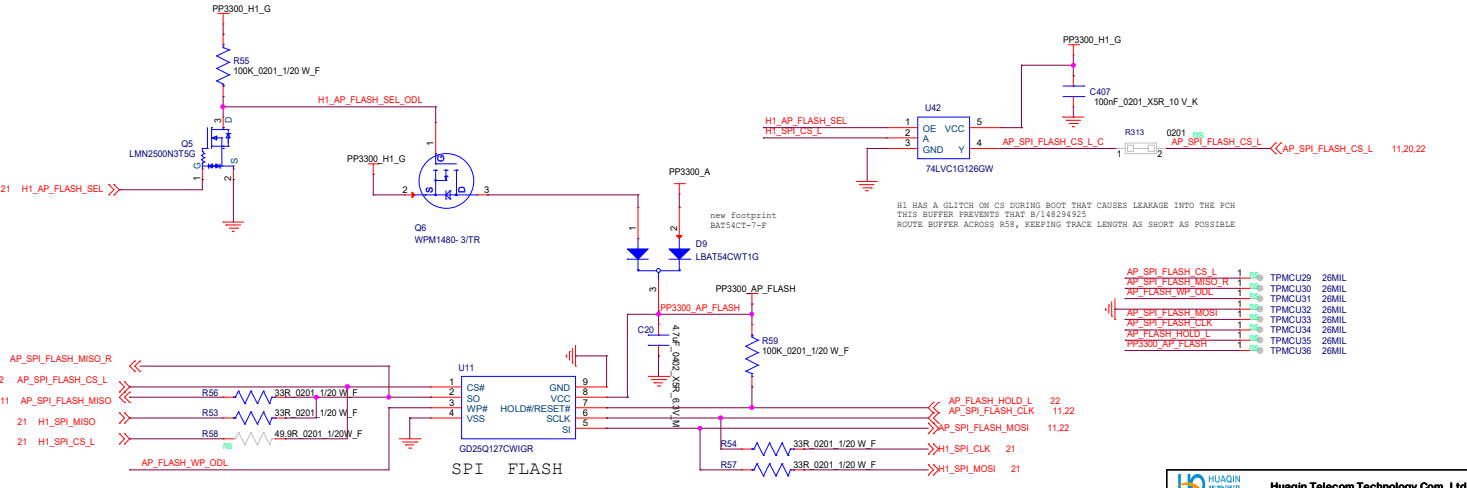
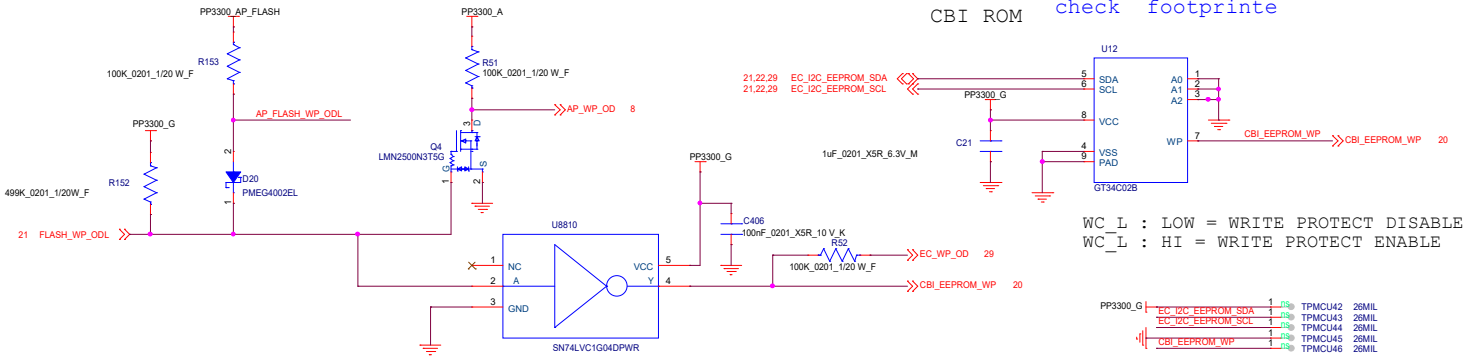

Huaqin Telecom Technology Com.,Ltd.	
COVER PAGE	
Page name:	JSL
Size: A4	Project Name: JSL
Date: Wednesday, July 14, 2021	REV: V1.0
Sheet: 20	of 47

18ML TP1 1 UART_DBG_TX_AP_RX → UART_DBG_TX_AP_RX 10.21
 18ML TP1 1 UART_AP_TX_DBG_RX → UART_AP_TX_DBG_RX 10.21

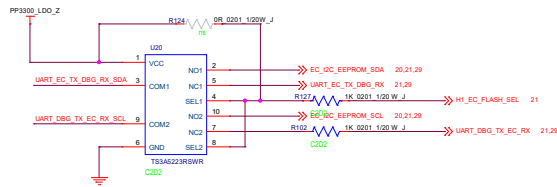
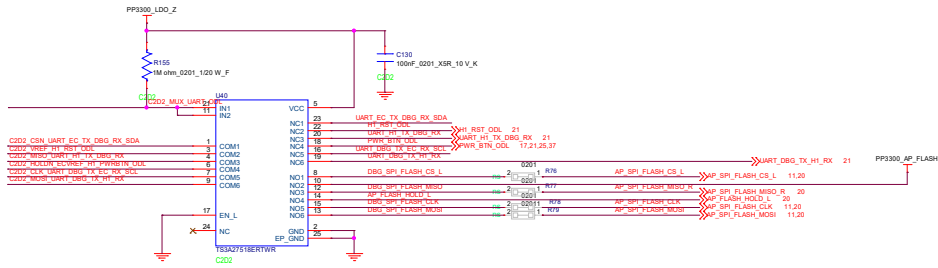
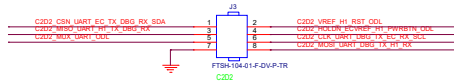

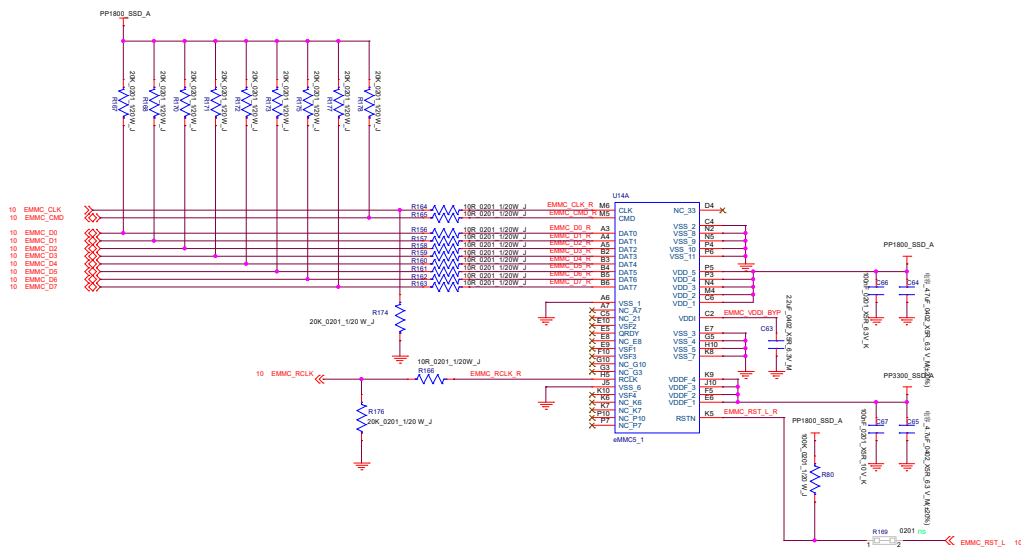

L-Speaker

R-Speaker

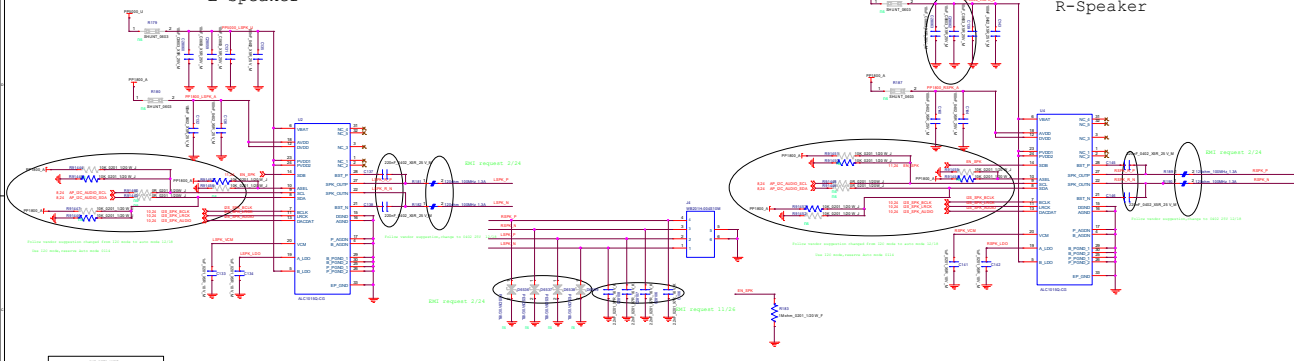

REV	DATE	BY	CHK	DESCRIPTION
1				
2				
3				
4				
5				

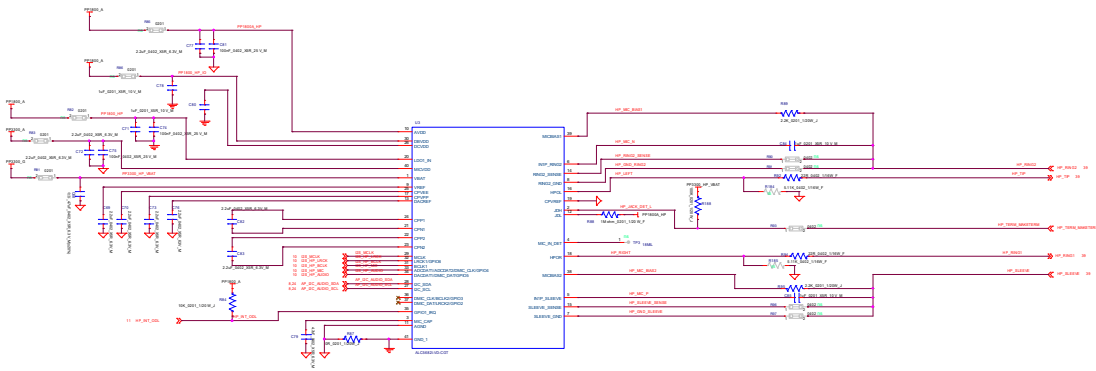

Track Pad

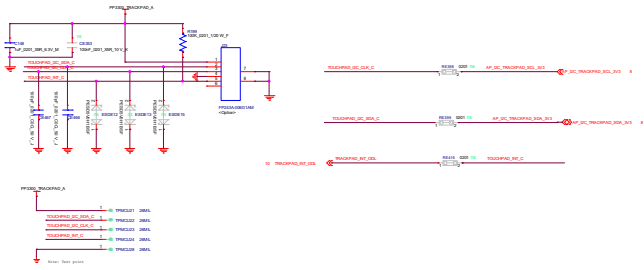

Buttons_Flip only

KB CONN

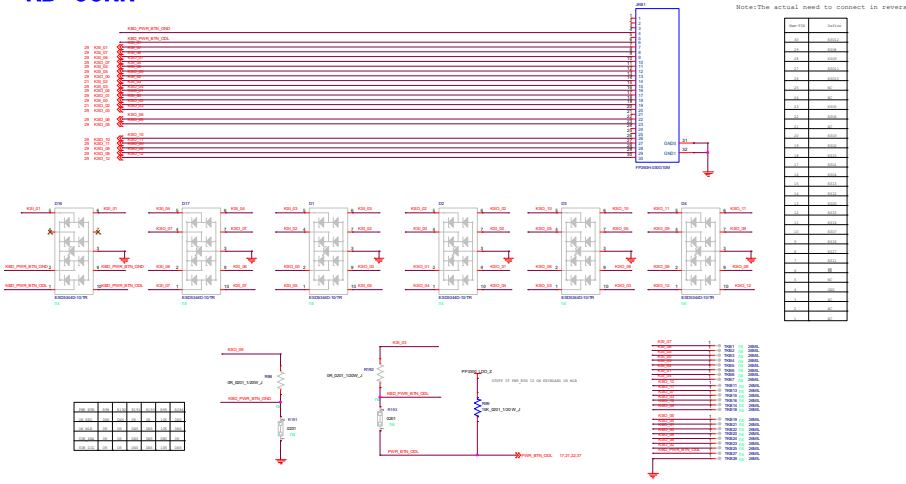

Combo LED

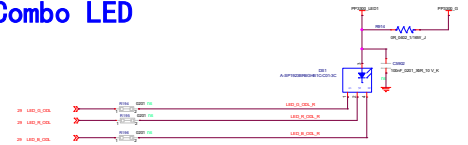

GMK Sensor change to Hall sensor

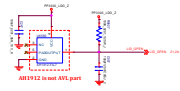

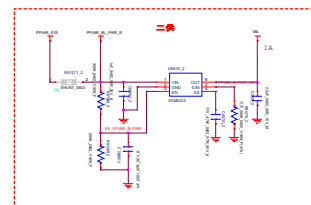
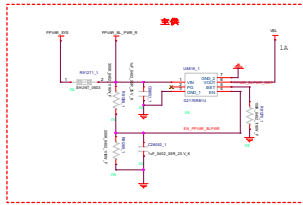
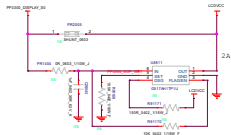
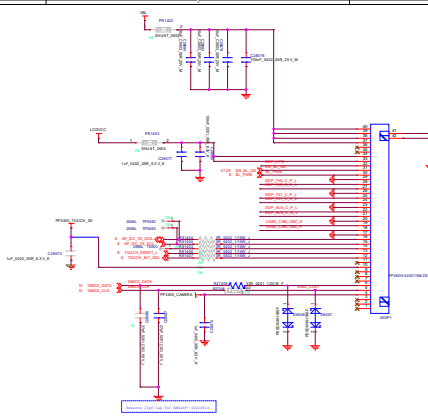
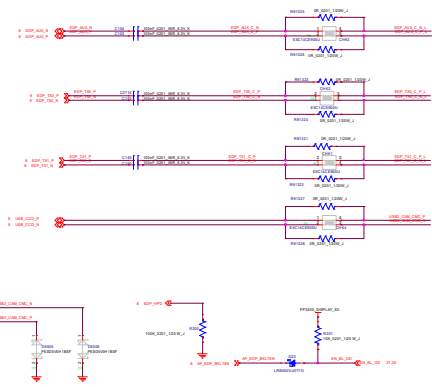

RISE TIME : < 5 MS > 0.5 MS
 RAMP OFF FALL TIME : > 5MS

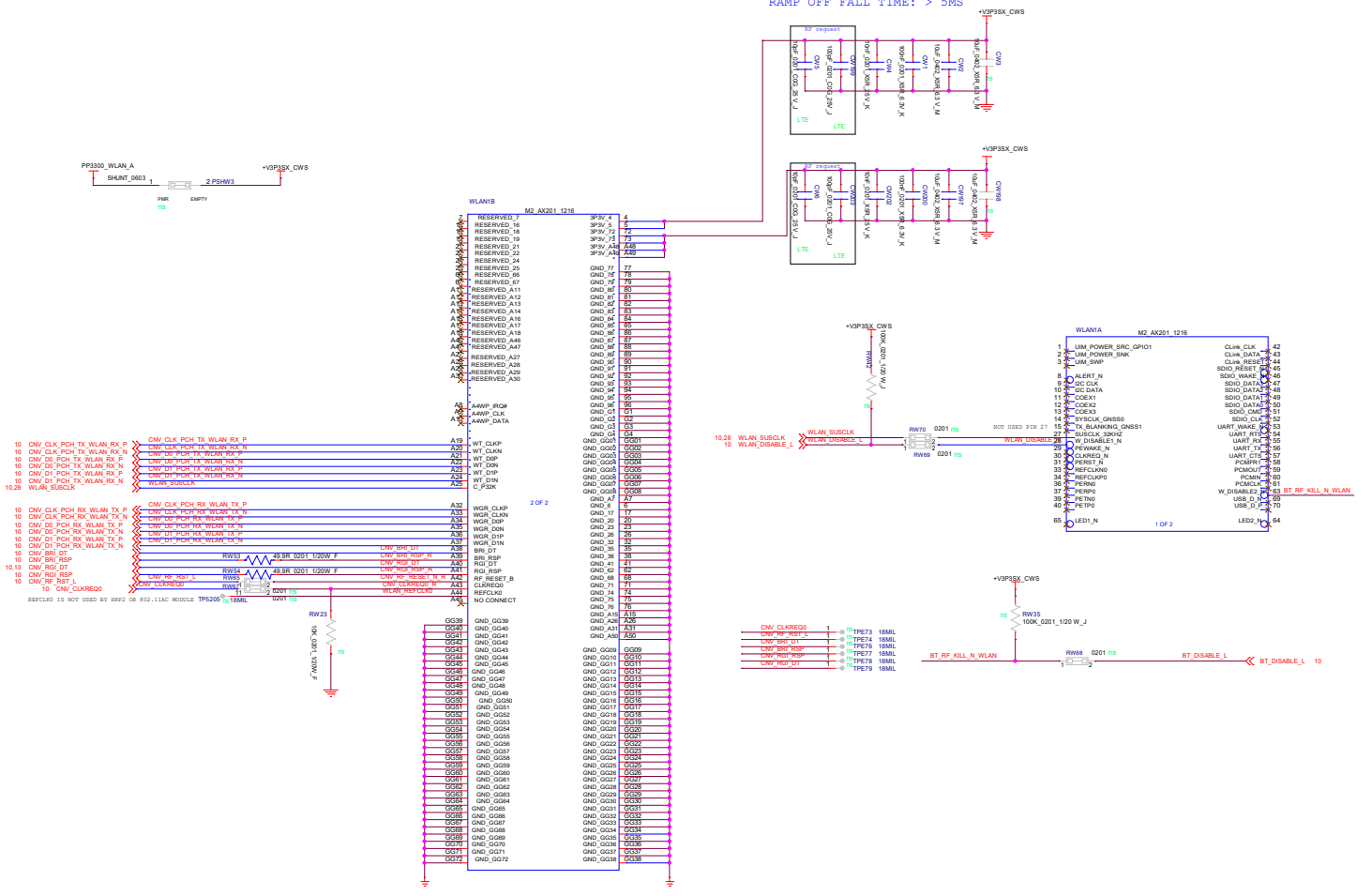

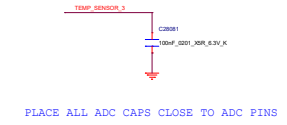
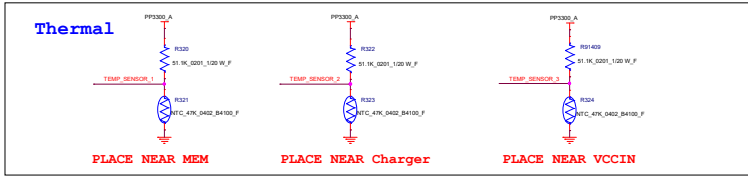
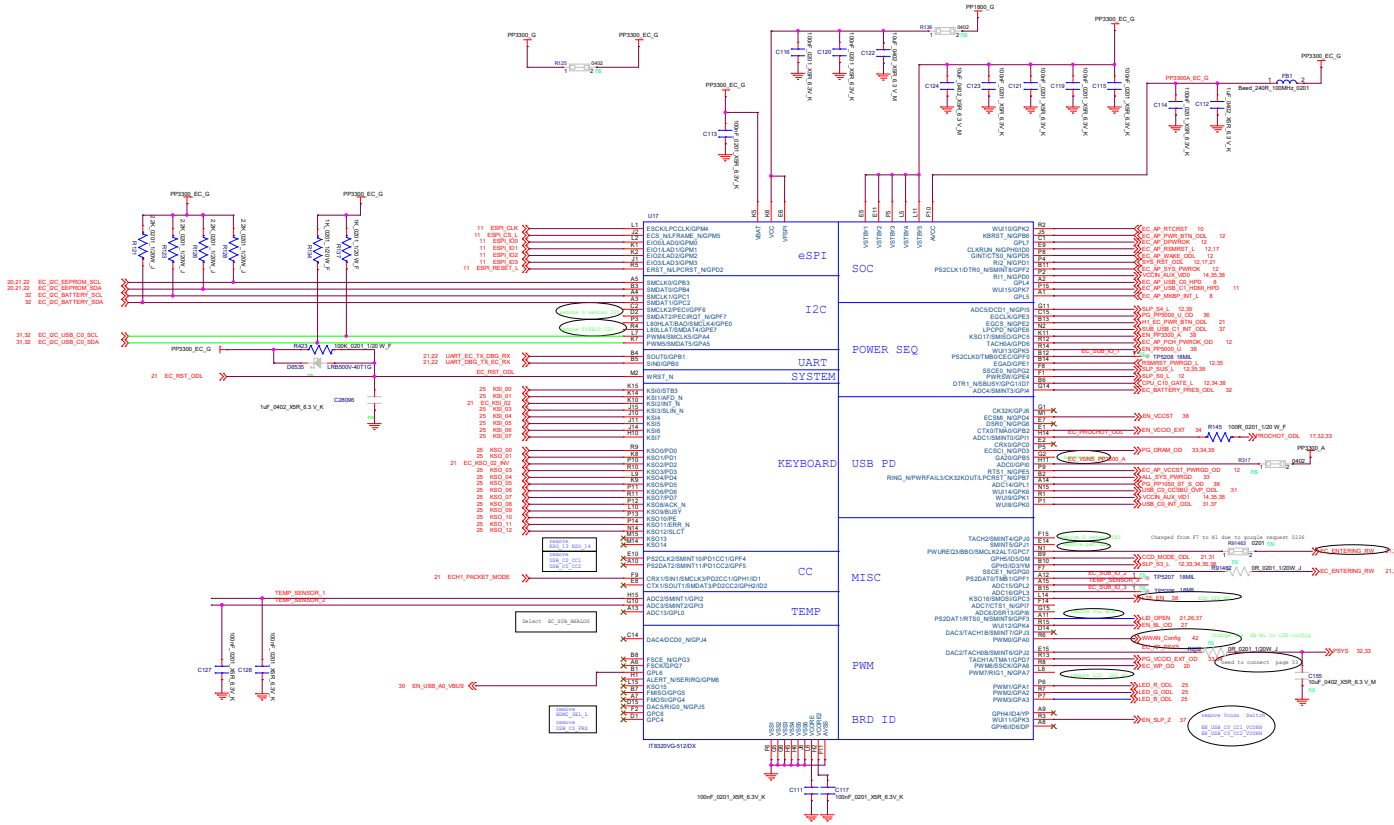

Limit TYPE RES LO(MA) HI(MA)
CSP 15.0K 1507 1 2752
SDP 1 25.5K 916 1 1075

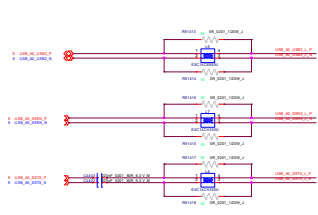

USB1 ESD

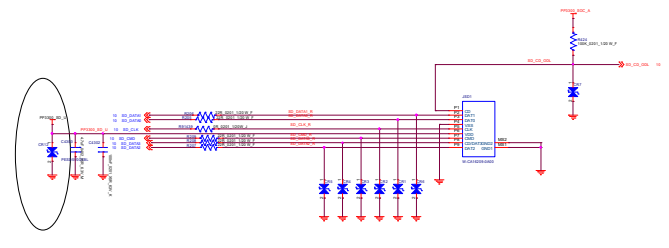
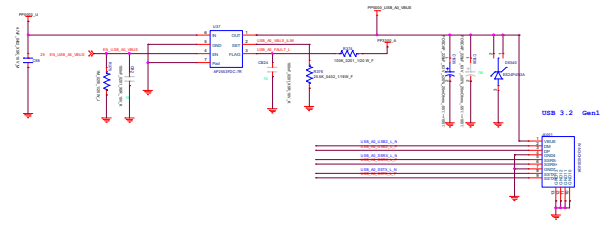
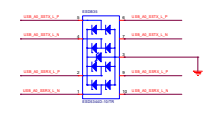

CC and SBU Protect

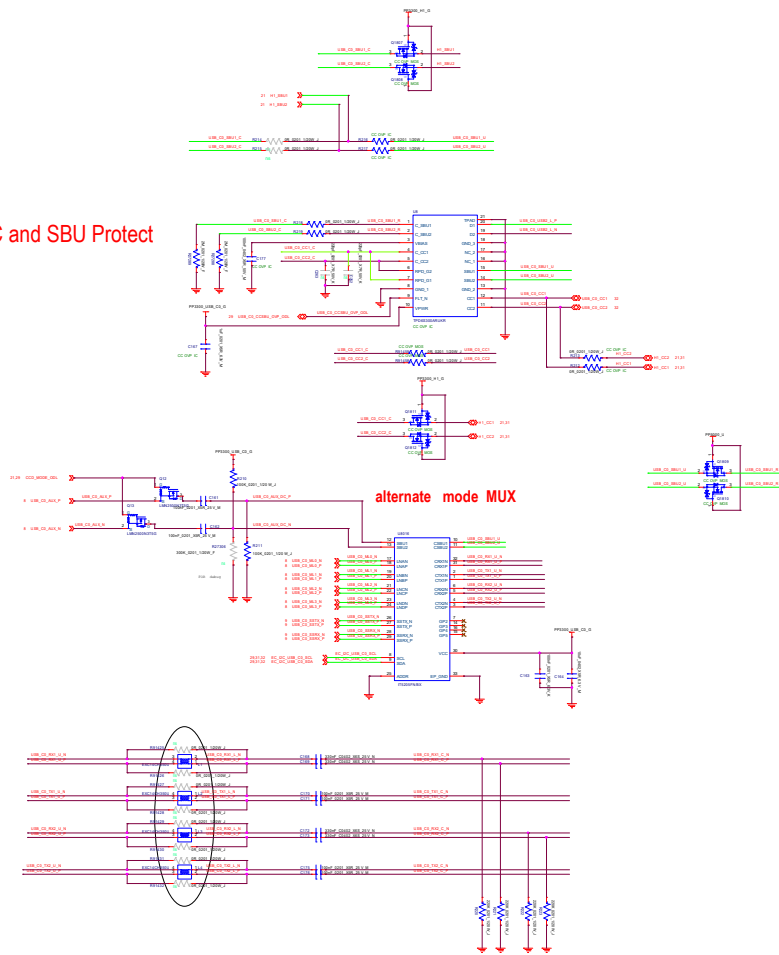

TypeC connector

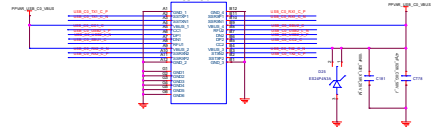

BC1.2

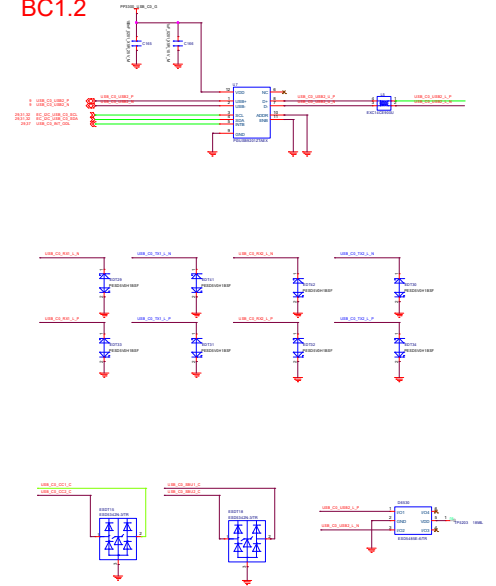

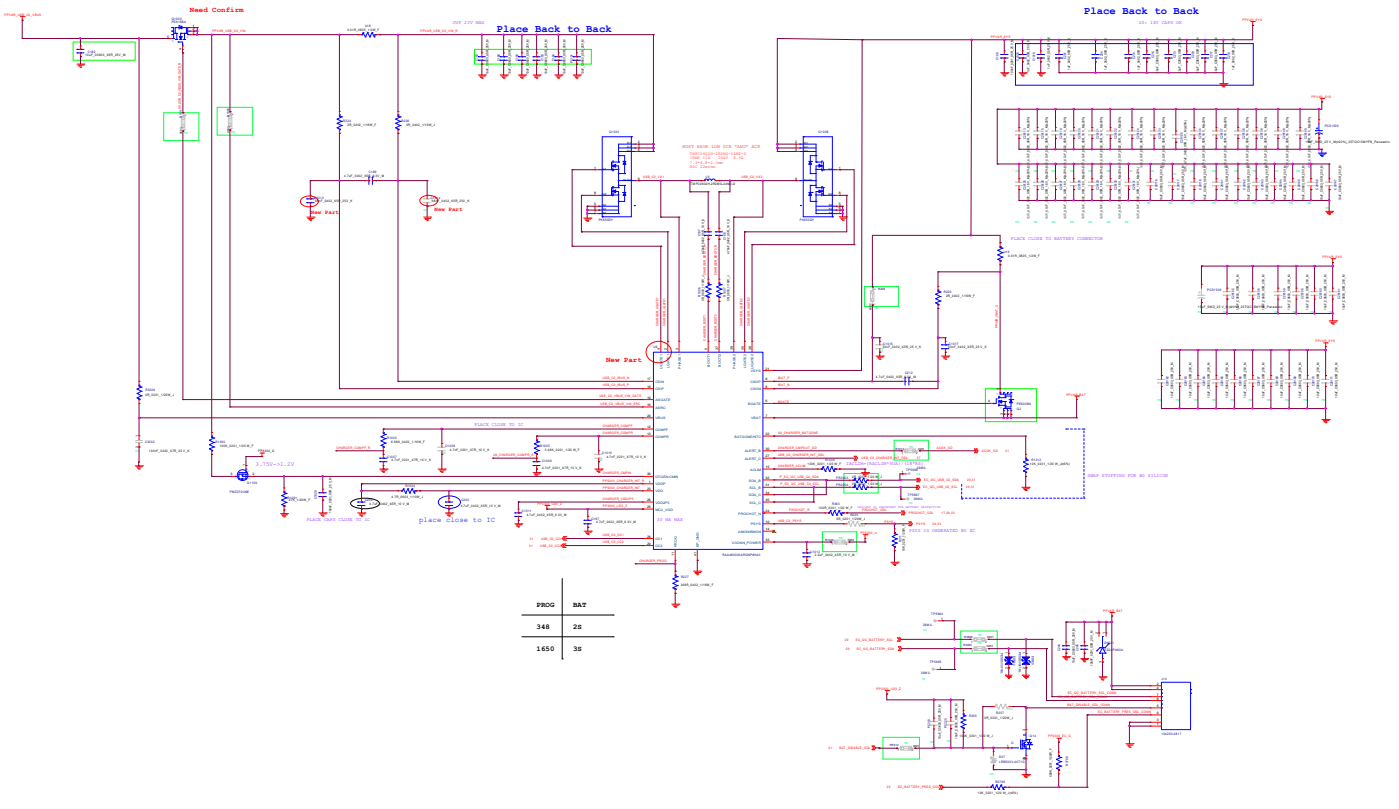

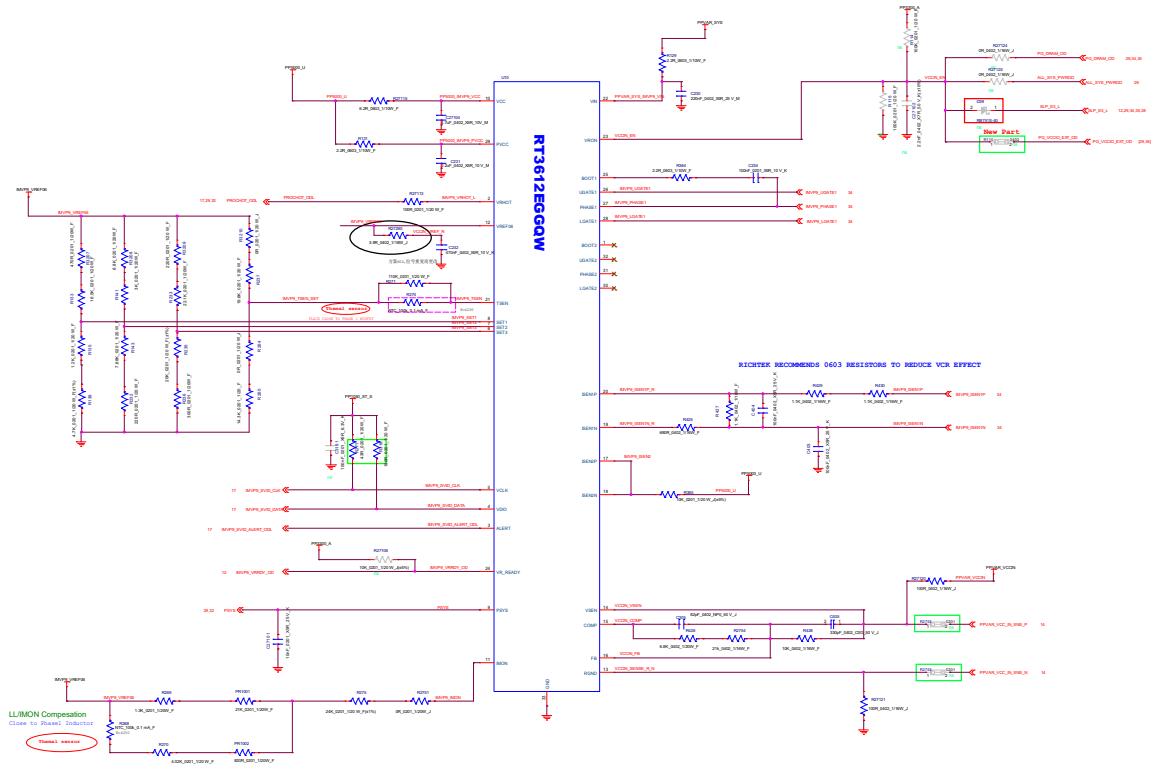

Pin	Part	Value	Notes
1	SW	10µF	Electrolytic
2	SW	10µF	Electrolytic
3	SW	10µF	Electrolytic
4	SW	10µF	Electrolytic
5	SW	10µF	Electrolytic
6	SW	10µF	Electrolytic
7	SW	10µF	Electrolytic
8	SW	10µF	Electrolytic
9	SW	10µF	Electrolytic
10	SW	10µF	Electrolytic
11	SW	10µF	Electrolytic
12	SW	10µF	Electrolytic
13	SW	10µF	Electrolytic
14	SW	10µF	Electrolytic
15	SW	10µF	Electrolytic
16	SW	10µF	Electrolytic
17	SW	10µF	Electrolytic
18	SW	10µF	Electrolytic
19	SW	10µF	Electrolytic
20	SW	10µF	Electrolytic
21	SW	10µF	Electrolytic
22	SW	10µF	Electrolytic
23	SW	10µF	Electrolytic
24	SW	10µF	Electrolytic
25	SW	10µF	Electrolytic
26	SW	10µF	Electrolytic
27	SW	10µF	Electrolytic
28	SW	10µF	Electrolytic
29	SW	10µF	Electrolytic
30	SW	10µF	Electrolytic
31	SW	10µF	Electrolytic
32	SW	10µF	Electrolytic
33	SW	10µF	Electrolytic
34	SW	10µF	Electrolytic
35	SW	10µF	Electrolytic
36	SW	10µF	Electrolytic
37	SW	10µF	Electrolytic
38	SW	10µF	Electrolytic
39	SW	10µF	Electrolytic
40	SW	10µF	Electrolytic
41	SW	10µF	Electrolytic
42	SW	10µF	Electrolytic
43	SW	10µF	Electrolytic
44	SW	10µF	Electrolytic
45	SW	10µF	Electrolytic
46	SW	10µF	Electrolytic
47	SW	10µF	Electrolytic
48	SW	10µF	Electrolytic
49	SW	10µF	Electrolytic
50	SW	10µF	Electrolytic
51	SW	10µF	Electrolytic
52	SW	10µF	Electrolytic
53	SW	10µF	Electrolytic
54	SW	10µF	Electrolytic
55	SW	10µF	Electrolytic
56	SW	10µF	Electrolytic
57	SW	10µF	Electrolytic
58	SW	10µF	Electrolytic
59	SW	10µF	Electrolytic
60	SW	10µF	Electrolytic
61	SW	10µF	Electrolytic
62	SW	10µF	Electrolytic
63	SW	10µF	Electrolytic
64	SW	10µF	Electrolytic
65	SW	10µF	Electrolytic
66	SW	10µF	Electrolytic
67	SW	10µF	Electrolytic
68	SW	10µF	Electrolytic
69	SW	10µF	Electrolytic
70	SW	10µF	Electrolytic
71	SW	10µF	Electrolytic
72	SW	10µF	Electrolytic
73	SW	10µF	Electrolytic
74	SW	10µF	Electrolytic
75	SW	10µF	Electrolytic
76	SW	10µF	Electrolytic
77	SW	10µF	Electrolytic
78	SW	10µF	Electrolytic
79	SW	10µF	Electrolytic
80	SW	10µF	Electrolytic
81	SW	10µF	Electrolytic
82	SW	10µF	Electrolytic
83	SW	10µF	Electrolytic
84	SW	10µF	Electrolytic
85	SW	10µF	Electrolytic
86	SW	10µF	Electrolytic
87	SW	10µF	Electrolytic
88	SW	10µF	Electrolytic
89	SW	10µF	Electrolytic
90	SW	10µF	Electrolytic
91	SW	10µF	Electrolytic
92	SW	10µF	Electrolytic
93	SW	10µF	Electrolytic
94	SW	10µF	Electrolytic
95	SW	10µF	Electrolytic
96	SW	10µF	Electrolytic
97	SW	10µF	Electrolytic
98	SW	10µF	Electrolytic
99	SW	10µF	Electrolytic
100	SW	10µF	Electrolytic

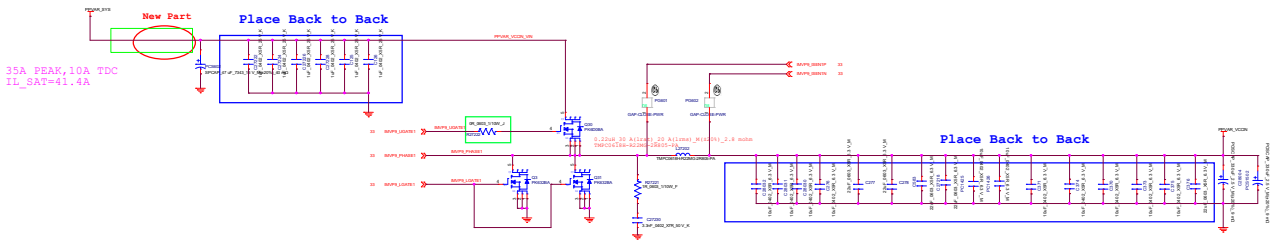

VCCIO EXT
 IPEAK=6.5A
 IL SAT=7.3A
 FSW=560KHZ

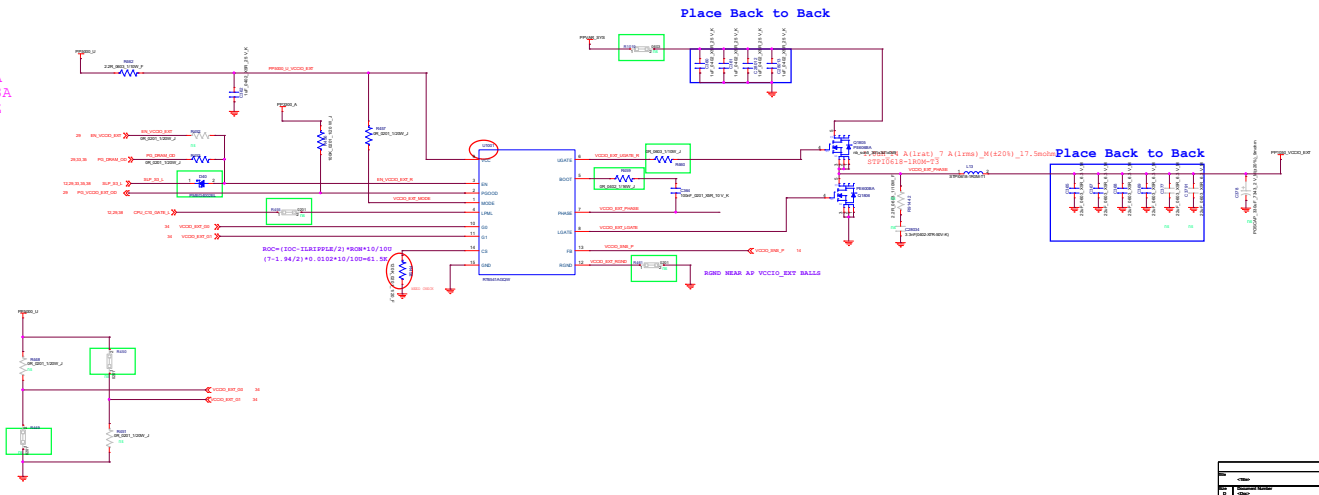

Item	Description	Quantity
1
2
3
4
5
6
7
8
9
10
11
12
13
14
15
16
17
18
19
20
21
22
23
24
25
26
27
28
29
30
31
32
33
34
35
36
37
38
39
40
41
42
43
44
45
46
47
48
49
50

24.0A PEAK I/OA

Place Back to Back

+VCCIN_AUX		
FOC	C13183	
2.2uF	4+49C1	4+49C1
15uF	4+49C1	4+49C1
22uF	49C1	34P13
47uF	E	230uF 5P

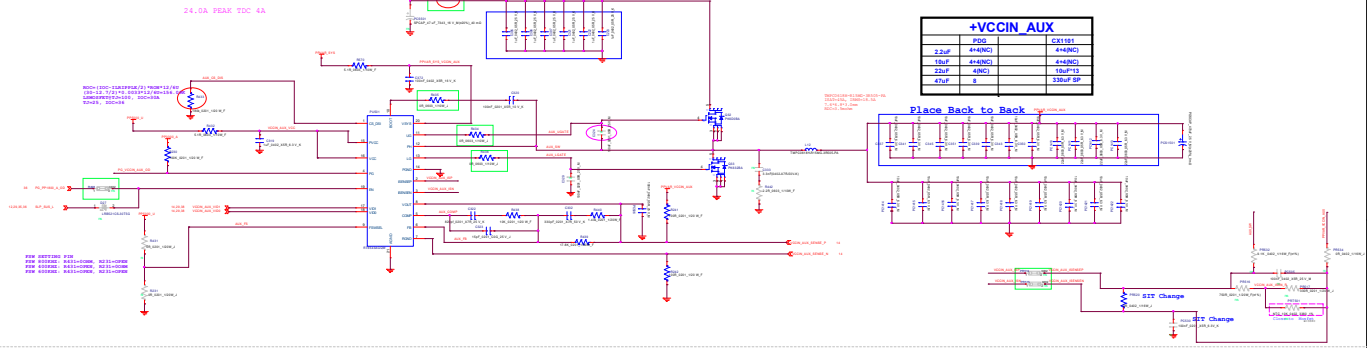

PFVAR_VNNEXT & PF1050_VI05EXT BYPASS RAILS

Place Back to Back

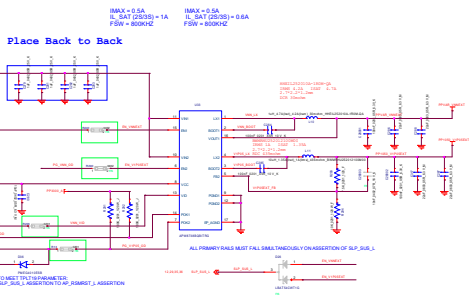

PF1800_DRAM_U

PF1100_DRAM_U

PF600_DRAM_U

NEED CHECK

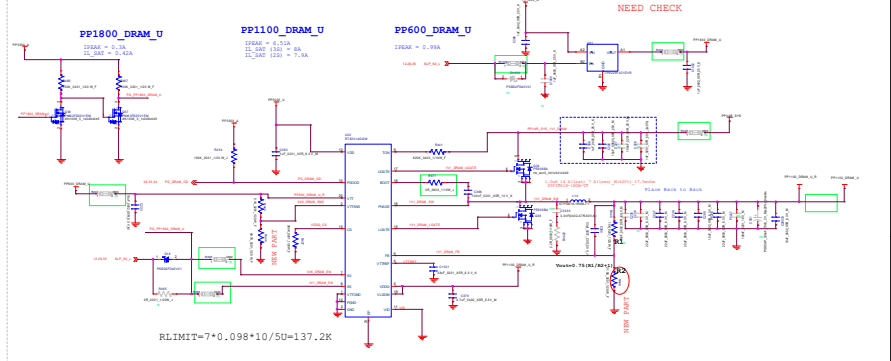

Rev	By	Date	Description
1			

PP5000_U

PEAK CURRENT: 3.3A
IL_SAT (2S): 4.90A
IL_SAT (3S): 5.74A

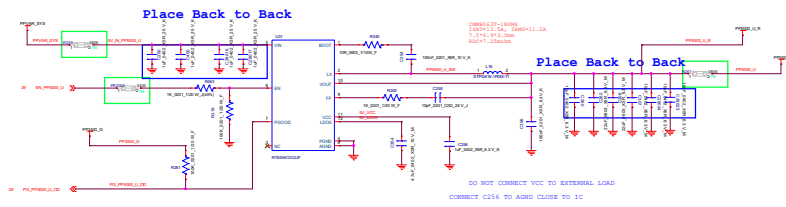

PP1800_A

IL_SAT (2S): 4.06A
PEAK CURRENT: 2.94A
IL_SAT (3S): 4.16A

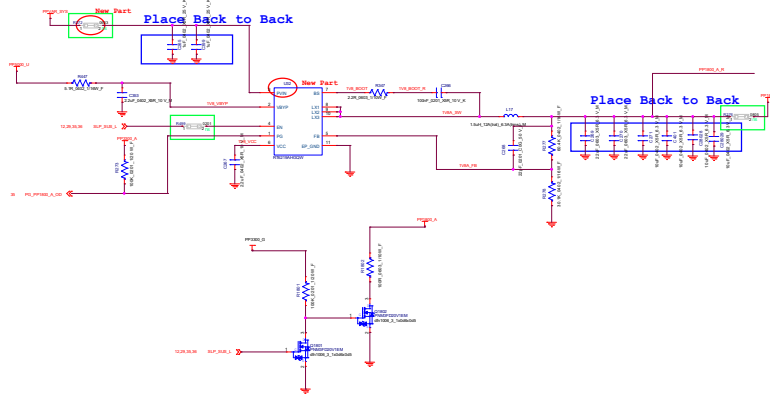

Rev	Date	By	Appr
1			

PP3300 G
 PEAK CURRENT: 4.06A
 IL SAT (2S): 6.47A
 IL SAT (3S): 6.96A

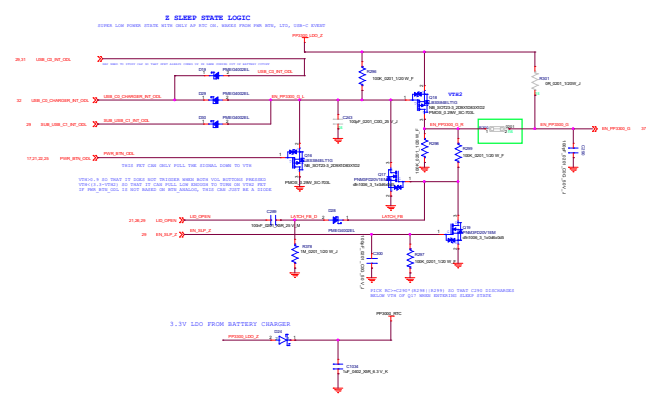
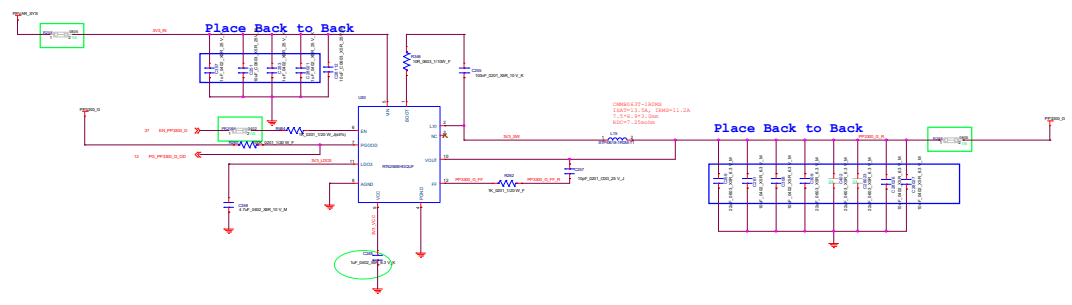

Rev	Description	Date
1	Initial Release	2023-10-27

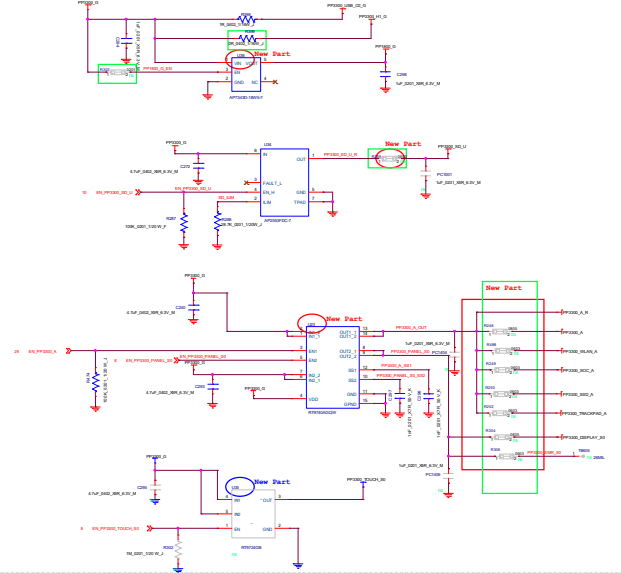

Remove WFC power

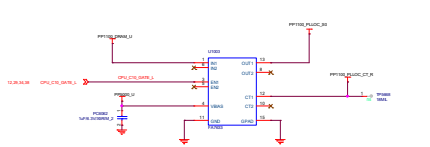
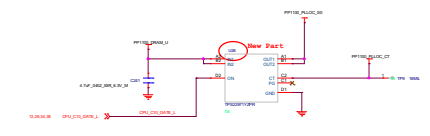
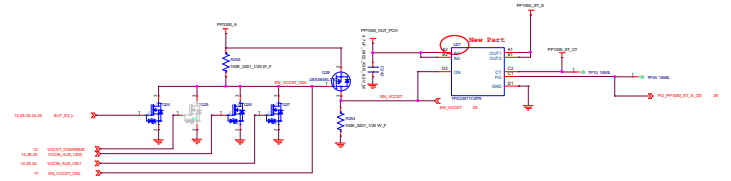
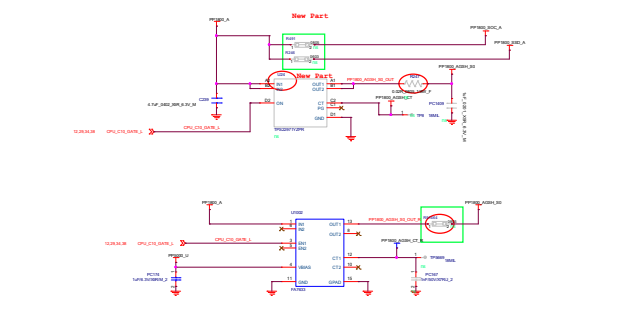
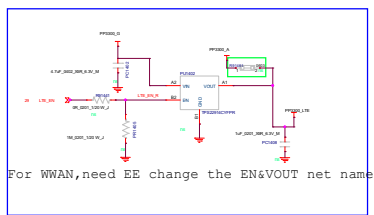
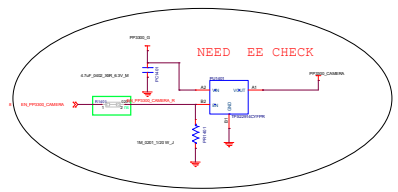

Rev	
1	Initial Release

MB to SUB connector

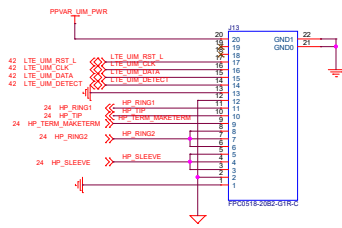

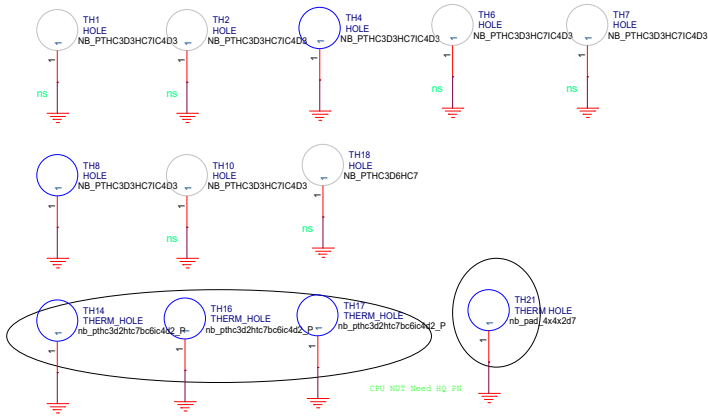

Memory

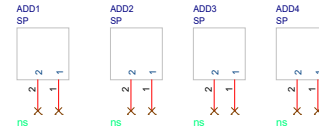
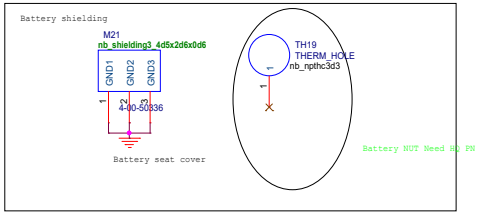
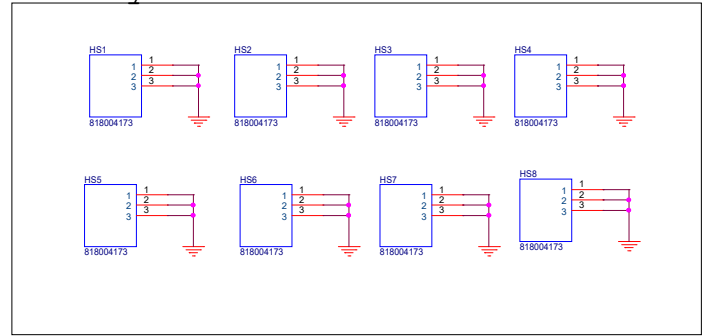

Huaqin Telecom Technology Com.,Ltd.	
Page name: COVER PAGE	
Size: A4	Project Name: JSL
Date: Wednesday, July 14, 2021	REV: V1.0 Sheet: 40 of 47

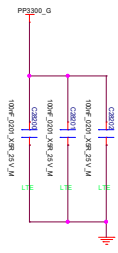
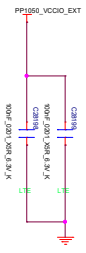
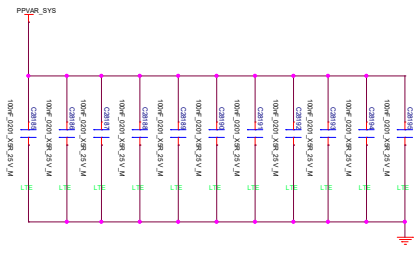
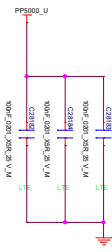
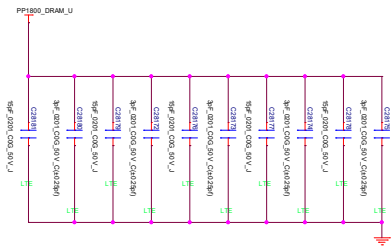

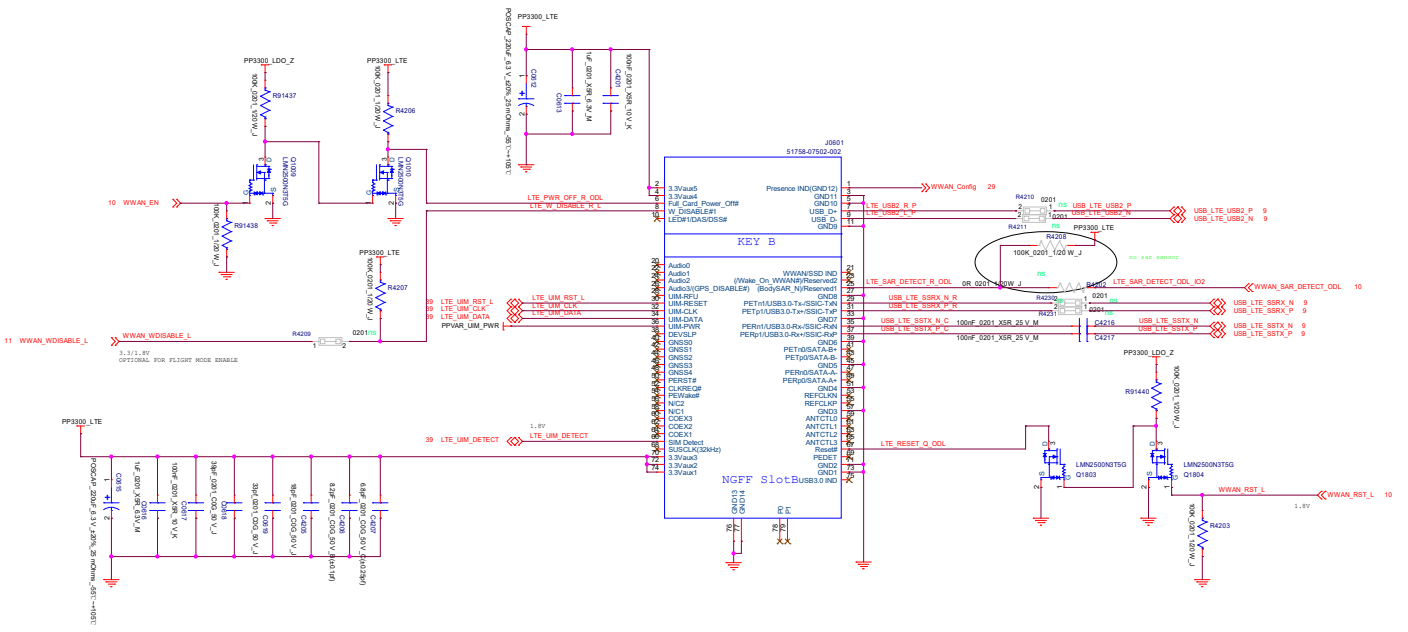

Rev	<Title>	
Doc	Doc Number	Rev
Code	Code	Code
Date	Wednesday, July 14, 2011	Sheet 42 of 47

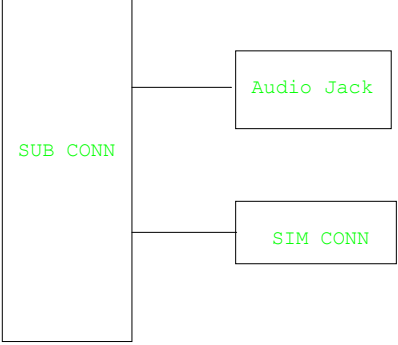

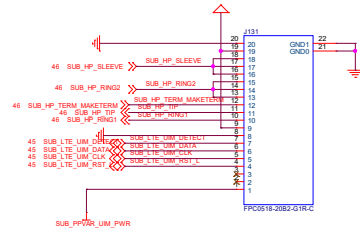

SIM Connector

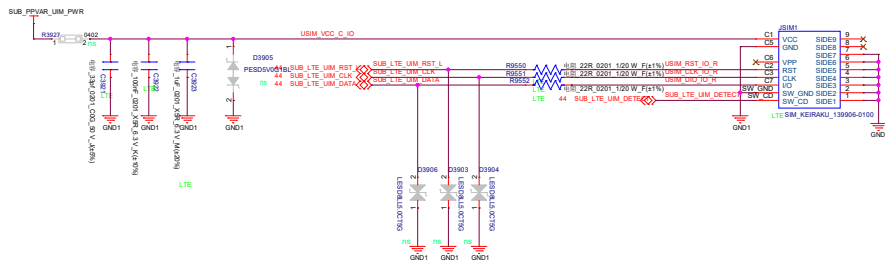

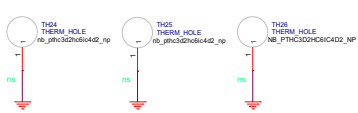
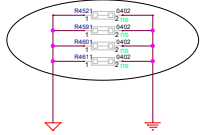
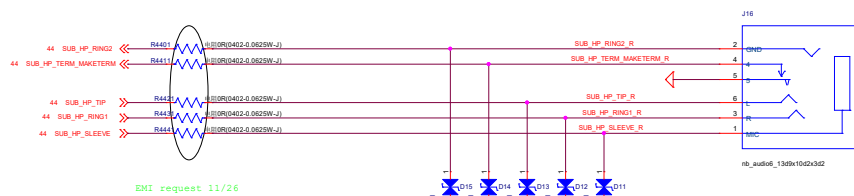

V3----->V4

EE Changelist:

- 1、 change EDP footprint,change HQ_CODE
- 2、 change C1035 stuff,C1036 not stuff
- 3、 R400/R401/R1014/R76/R77/R78/R79/R179/R180/R186/R187/R85/R86/
R83/R82/R81/PR1402/PR1403/PR2005/R91271 1/R91271 2/R125/R136/R4521/
R4591/R4601/R4611/R3927/R4210/R4211/R4230/R4231/R27208/R7/R3903/
RW65/RW67 change 0R to shortpad
- 4、 ns TH1/TH2/TH6/TH7/TH10/TH18/TH20/TH22/TH23/TH24/TH25/TH26, add PCB
- 5、 add D6507/D6508

Title		
<Title>		
Size	Document Number	Rev
A	<Doc>	<Rev Co
Date:	Wednesday, July 14, 2021	Sheet 47 of 47