



FCC PART 15C TEST REPORT No.I23Z70209-IOT03

for

Client name: Samsung Electronics Co., Ltd.

Product name: Tablet with Bluetooth, WLAN

Model name: SM-X210

With

FCC ID: ZCASM210

Hardware Version: REV1.0

Software Version: X210.001

Issued Date: 2023-08-29

Note:

The test results in this test report relate only to the devices specified in this report. This report shall not be reproduced except in full without the written approval of CTTL.

The report must not be used by the client to claim product certification, approval, or endorsement by NVLAP, NIST, or any agency of the U.S. Government.

Test Laboratory:

CTTL-Telecommunication Technology Labs, CAICT

No. 52, Huayuan North Road, Haidian District, Beijing, P. R. China 100191.

Tel:+86(0)10-62304633-2512, Fax:+86(0)10-62304633-2504

Email: ctl_terminals@caict.ac.cn, website: www.caict.ac.cn



REPORT HISTORY

Report Number	Revision	Description	Issue Date
I23Z70209-IOT03	Rev.0	1st edition	2023-08-29

CONTENTS

CONTENTS	3
1. TEST LATORATORY	5
1.1. INTRODUCTION & ACCREDITATION	5
1.2. TESTING LOCATION	5
1.3. TESTING ENVIRONMENT	6
1.4. PROJECT DATE	6
1.5. SIGNATURE	6
2. CLIENT INFORMATION	7
2.1. APPLICANT INFORMATION	7
2.2. MANUFACTURER INFORMATION	7
3. EQUIPMENT UNDER TEST (EUT) AND ANCILLARY EQUIPMENT(AE)	8
3.1. ABOUT EUT	8
3.2. INTERNAL IDENTIFICATION OF EUT USED DURING THE TEST	8
3.3. INTERNAL IDENTIFICATION OF AE USED DURING THE TEST	8
3.4. GENERAL DESCRIPTION	8
4. REFERENCE DOCUMENTS	9
4.1. DOCUMENTS SUPPLIED BY APPLICANT	9
4.2. REFERENCE DOCUMENTS FOR TESTING	9
5. LABORATORY ENVIRONMENT	9
6. SUMMARY OF TEST RESULTS	10
6.1. SUMMARY OF TEST RESULTS	10
6.2. STATEMENTS	10
6.3. TEST CONDITIONS	10
7. TEST EQUIPMENTS UTILIZED	11
8. MEASUREMENT UNCERTAINTY	12
8.1. TRANSMITTER OUTPUT POWER	12
8.2. PEAK POWER SPECTRAL DENSITY	12
8.3. OCCUPIED 6DB BANDWIDTH	12
8.4. BAND EDGES COMPLIANCE	12
8.5. SPURIOUS EMISSIONS	12
8.6. AC POWER-LINE CONDUCTED EMISSION	12
ANNEX A: MEASUREMENT RESULTS	13
A.1. MEASUREMENT METHOD	13
A.2. MAXIMUM PEAK OUTPUT POWER	14
A.2.1 ANTENNA GAIN	14
A.2.2. MAXIMUM AVERAGE OUTPUT POWER-CONDUCTED	14

A.3. PEAK POWER SPECTRAL DENSITY	17
A.4. OCCUPIED 6dB BANDWIDTH	18
A.5. TRANSMITTER SPURIOUS EMISSION	24
A.6. BAND EDGES COMPLIANCE	36
A.6.1 BAND EDGES - RADIATED	36
FIG. 10 BAND EDGES (802.11A CH149,5745MHZ).....	38
FIG. 11 BAND EDGES (802.11A CH165, 5825MHZ).....	38
FIG. 12 BAND EDGES (802.11N-HT20 CH149, 5745MHZ)	39
FIG. 13 BAND EDGES (802.11N-HT20 CH165, 5825MHZ)	39
FIG. 14 BAND EDGES (802.11N-HT40 CH151, 5755MHZ)	40
FIG. 15 BAND EDGES (802.11N-HT40 CH159, 5795MHZ)	40
FIG. 16 BAND EDGES (802.11AC-HT20 CH149, 5745MHZ)	41
FIG. 17 BAND EDGES (802.11AC-HT20 CH165, 5825MHZ)	41
FIG. 18 BAND EDGES (802.11AC-HT40 CH151, 5755MHZ)	42
FIG. 19 BAND EDGES (802.11AC-HT40 CH159, 5795MHZ)	42
FIG. 20 BAND EDGES (802.11AC-HT80 CH155, 5775MHZ)	43
FIG. 21 BAND EDGES (802.11AC-HT80 CH155, 5775MHZ)	43
A.7. AC POWERLINE CONDUCTED EMISSION.....	44
FIG.22 AC POWER LINE CONDUCTED EMISSION-802.11A.....	46
FIG.23 AC POWER LINE CONDUCTED EMISSION-IDLE	47
ANNEX B: EUT PARAMETERS.....	48
ANNEX C: ACCREDITATION CERTIFICATE	48



1. TEST LABORATORY

1.1. Introduction & Accreditation

Telecommunication Technology Labs, CAICT is an ISO/IEC 17025:2017 accredited test laboratory under American Association for Laboratory Accreditation (A2LA) with lab code 7049.01, and is also an FCC accredited test laboratory (CN5017), and ISED accredited test laboratory (CAB identifier:CN0066). The detail accreditation scope can be found on A2LA website.

1.2. Testing Location

Conducted testing Location: CTTL(huayuan North Road)

Address: No. 52, Huayuan North Road, Haidian District, Beijing,
P. R. China100191

Radiated testing Location:

CTTL (BDA)

Address: No. 18A, Kangding Street, Beijing Economic-Technology
Development Area, Beijing, 100176, P.R. China

CTTL(huayuan North Road)

Address: No. 52, Huayuan North Road, Haidian District, Beijing,
100191, P. R. China

1.3. Testing Environment

Normal Temperature: 15-35°C

Relative Humidity: 20-75%

1.4. Project date

Testing Start Date: 2023-07-24

Testing End Date: 2023-08-28

1.5. Signature



Yao Xingyu

(Prepared this test report)

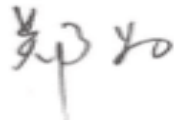

Zheng Wei

(Reviewed this test report)



Pang Shuai

(Approved this test report)



2. CLIENT INFORMATION

2.1. Applicant Information

Company Name: Samsung Electronics Co., Ltd.
Address: 19 Chapin Rd., Building D Pine Brook, NJ 07058
City: New Jersey
Postal Code: /
Country: U.S.
Telephone: +1-201-937-4203
Fax: /

2.2. Manufacturer Information

Company Name: Samsung Electronics Co., Ltd.
Address: Samsung R5, Maetan dong 129, Samsung ro
Youngtong gu, Suwon city 443 742, Korea
City: Suwon
Postal Code: /
Country: Korea
Telephone: +82 - 10 - 2722 - 4159
Fax: /

3. EQUIPMENT UNDER TEST (EUT) AND ANCILLARY

EQUIPMENT(AE)

3.1. About EUT

Description	Tablet with Bluetooth, WLAN
Model name	SM-X210
FCC ID	ZCASM210
WLAN Frequency Band	ISM Band: 5725MHz~5850MHz
Type of modulation	OFDM
Voltage	3.85V

3.2. Internal Identification of EUT used during the test

EUT ID*	IMEI	HW Version	SW Version
UT05a	2370209UT05a	REV1.0	X210.001
UT09a	2370209UT09a	REV1.0	X210.001

*EUT ID: is used to identify the test sample in the lab internally.

UT05a is used for Conduction test, UT09a is used for Radiation test.

3.3. Internal Identification of AE used during the test

AE ID*	Name	Model	Manufacturer
AE1	Battery	WT-S-W11	SCUD (Fujian) Electronics Co., Ltd.
AE2*	Adapter	EP-T1510	DONGGUAN DONGWON ELECTRONICS CO.,LTD.
AE3-1	Date Cable1 C-C	EP-DN980BWE	Guangxi Broad Telecommunication Co.,Ltd.
AE3-2	Date Cable2 C-C	EP-DN980BWE	RFTECH Co., Ltd.
AE3-3	Date Cable3 C-C	EP-DN980BWE	CRESYN HANOI Co., Ltd
AE5*	Headset	ESH61ASFWE	/

*AE ID: is used to identify the test sample in the lab internally.

*AE2 and A5 are not the AE for EUT, provided by the client for relevant tests.

3.4. General Description

Equipment Under Test (EUT) is a model of Tablet with Bluetooth, WLAN with integrated antenna. It consists of normal options: Battery and Charger.

Manual and specifications of the EUT were provided to fulfil the test.

Samples undergoing test were selected by the Client.

4. REFERENCE DOCUMENTS

4.1. Documents supplied by applicant

EUT feature information is supplied by the applicant or manufacturer, which is the basis of testing.

4.2. Reference Documents for testing

The following documents listed in this section are referred for testing.

FCC Part15	FCC CFR 47, Part 15, Subpart C and E: 15.205 Restricted bands of operation; 15.209 Radiated emission limits, general requirements; 15.407 General technical requirements	2021
ANSI C63.10	Methods of Measurement of Radio-Noise Emissions from Low-Voltage Electrical and Electronic Equipment in the Range of 9 kHz to 40 GHz	2013
KDB 558074 D01	Federal Communications Commission Office of Engineering and Technology Laboratory Division GUIDANCE FOR COMPLIANCE MEASUREMENTS ON DIGITAL TRANSMISSION SYSTEM, FREQUENCY HOPPING SPREAD SPECTRUM SYSTEM, AND HYBRID SYSTEM DEVICES OPERATING UNDER SECTION 15.247 OF THE FCC RULES	2019

5. LABORATORY ENVIRONMENT

Conducted RF performance testing is performed in shielding room.

EMC performance testing is performed in Semi-anechoic chamber.

6. SUMMARY OF TEST RESULTS

6.1. Summary of Test Results

SUMMARY OF MEASUREMENT RESULTS	Sub-clause of Part15C	Sub-clause of IC	Verdict
Maximum Peak Output Power	15.407 (a)	/	P
Peak Power Spectral Density	15.407 (a)	/	P
Occupied 6dB Bandwidth	15.407 (e)	/	P
Band Edges Compliance - Conducted& Radiated	15.407 (b)	/	P
Transmitter Spurious Emission - Conducted	15.407	/	P
Transmitter Spurious Emission - Radiated	15.407, 15.205, 15.209	/	P
AC Powerline Conducted Emission	15.107, 15.207	/	P

Please refer to **ANNEX A** for detail.

Terms used in Verdict column

P	Pass, The EUT complies with the essential requirements in the standard.
NM	Not measured, The test was not measured by CTTL
NA	Not Applicable, The test was not applicable
F	Fail, The EUT does not comply with the essential requirements in the standard

6.2. Statements

CTTL has evaluated the test cases requested by the client/matrix manufacturer as listed in section 6.1 of this report for the EUT specified in section 3 according to the standards or reference documents listed in section 4.1.

This report only deals with the WLAN function among the features described in section 3.

6.3. Test Conditions

For this report, all the test cases are tested under normal temperature and normal voltage, and also under norm humidity, the specific condition is shown as follows:

Temperature	26°C
Voltage	3.85V
Humidity	44%

7. TEST EQUIPMENTS UTILIZED

Conducted test system

No.	Equipment	Model	Serial Number	Manufacturer	Calibration Period	Calibration Due date
1	Vector Signal Analyzer	FSQ40	200089	Rohde & Schwarz	1 year	2024-07-04
2	Attenuator	10dB/2W	/	Rosenberger	/	/
3	Shielding Room	S81	/	ETS-Lindgren	/	/

Radiated emission test system

No.	Equipment	Model	Serial Number	Manufacturer	Calibration Period	Calibration Due date
1	Test Receiver	ESU26	100376	R&S	1 year	2023-09-22
2	Test Receiver	ESW44	103015	R&S	1 year	2024-01-14
3	Test Receiver	ESW44	103144	R&S	1 year	2023-10-25
4	Test Receiver	FSV40	101047	R&S	1 year	2024-06-25
5	Loop Antenna	HFH2-Z2	829324/007	R&S	1 year	2023-12-22
6	EMI Antenna	VULB9163	01177	Schwarzbeck	1 year	2023-09-03
7	EMI Antenna	3117	00139065	ETS-Lindgren	1 year	2023-10-05
8	EMI Antenna	LB-180400 -25-C-KF	21100840000 06	A-INFO	1 year	2024-03-02

AC Power Line Conducted Emission

No.	Equipment	Model	Serial Number	Manufacturer	Calibration Period	Calibration Due date
1	LISN	ENV216	101459	R&S	1 year	2024-02-29
2	Test Receiver	ESCI	100766	R&S	1 year	2024-03-30

8. Measurement Uncertainty

8.1. Transmitter Output Power

Measurement Uncertainty: 0.387dB,k=1.96

8.2. Peak Power Spectral Density

Measurement Uncertainty: 0.705dB,k=1.96

8.3. Occupied 6dB Bandwidth

Measurement Uncertainty: 60.80Hz,k=1.96

8.4. Band Edges Compliance

Measurement Uncertainty : 0.62dB,k=1.96

8.5. Spurious Emissions

Conducted (k=1.96)

Frequency Range	Uncertainty(dB)
$30\text{MHz} \leq f \leq 2\text{GHz}$	1.22
$2\text{GHz} \leq f \leq 3.6\text{GHz}$	1.22
$3.6\text{GHz} \leq f \leq 8\text{GHz}$	1.22
$8\text{GHz} \leq f \leq 12.75\text{GHz}$	1.51
$12.75\text{GHz} \leq f \leq 26\text{GHz}$	1.51
$26\text{GHz} \leq f \leq 40\text{GHz}$	1.59

Radiated (k=2)

Frequency Range	Uncertainty(dB)
9kHz-30MHz	4.92
$30\text{MHz} \leq f \leq 1\text{GHz}$	5.73
$1\text{GHz} \leq f \leq 18\text{GHz}$	5.62
$18\text{GHz} \leq f \leq 40\text{GHz}$	3.37

8.6. AC Power-line Conducted Emission

Measurement Uncertainty : 3.10dB,k=2

ANNEX A: MEASUREMENT RESULTS

A.1. Measurement Method

A.1.1. Conducted Measurements

- 1). Connect the EUT to the test system correctly.
- 2). Set the EUT to the required work mode.
- 3). Set the EUT to the required channel.
- 4). Set the spectrum analyzer to start measurement.
- 5). Record the values. Vector Signal Analyzer

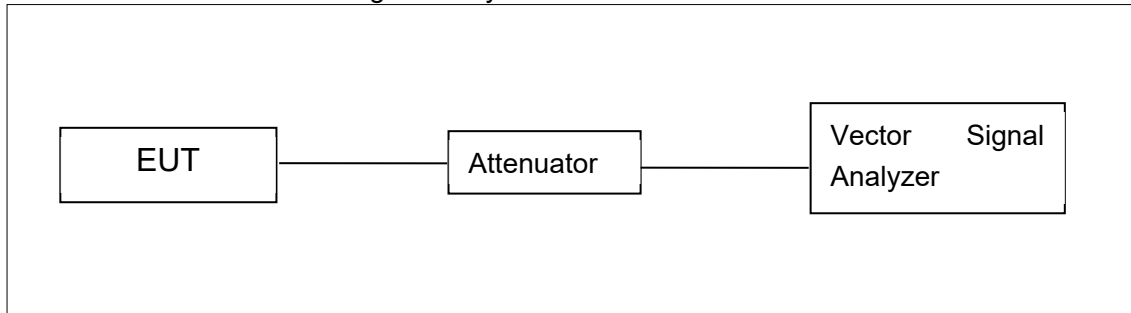

A.1.2. Radiated Emission Measurements

In the case of radiated emission, the used settings are as follows,

Sweep frequency from 30 MHz to 1GHz, RBW = 100 kHz, VBW = 300 kHz;

Sweep frequency from 1 GHz to 26GHz, RBW = 1MHz, VBW = 3MHz;

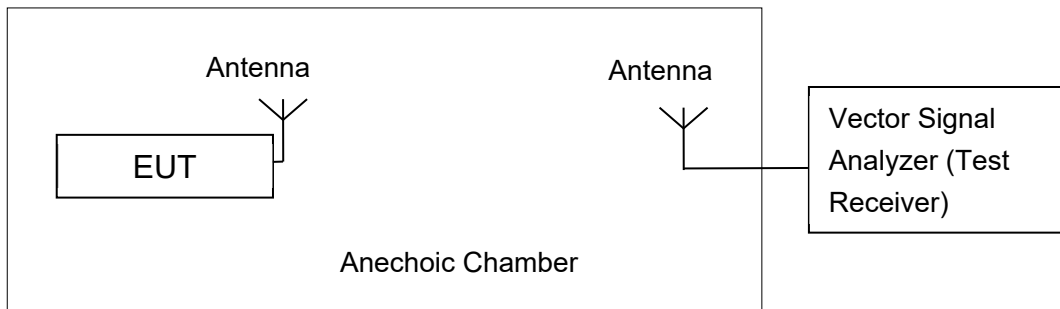

The measurement is made according to ANSI C63.10.

The radiated emission test is performed in semi-anechoic chamber. The distance from the EUT to the reference point of measurement antenna is 3m. The test is carried out on both vertical and horizontal polarization and only maximization result of both polarizations is kept. During the test, the turntable is rotated 360° and the measurement antenna is moved from 1m to 4m to get the maximization result.

A.2. Maximum Peak Output Power

Measurement Limit and Method:

Standard	Limit (dBm)
FCC CRF Part 15.407(a)	< 30

A.2.1 Antenna Gain

Antenna gain is -1.75dBi and the value is supplied by the applicant or manufacturer.

A.2.2. Maximum Average Output Power-Conducted

Measurement Results:

802.11a mode

Mode	Data Rate (Mbps)	Test Result (dBm)		
		5745MHz (Ch149)	5785MHz (Ch157)	5825MHz (Ch165)
802.11a	6	17.19	17.38	17.06
	9	16.60	/	/
	12	16.61	/	/
	18	16.12	/	/
	24	16.10	/	/
	36	15.70	/	/
	48	15.50	/	/
	54	15.08	/	/

The data rate 6Mbps is selected as worst condition, and the following cases are performed with this condition.

802.11n-HT20 mode

Mode	Data Rate (Index)	Test Result (dBm)		
		5745MHz (Ch149)	5785MHz (Ch157)	5825MHz (Ch165)
802.11n (20MHz)	MCS0	17.19	17.35	17.04
	MCS1	16.70	/	/
	MCS2	16.68	/	/
	MCS3	16.15	/	/
	MCS4	15.88	/	/
	MCS5	15.64	/	/
	MCS6	15.55	/	/
	MCS7	15.20	/	/

The data rate MSC0 is selected as worst condition, and the following cases are performed with this condition.

802.11ac-HT20 mode

Mode	Data Rate (Index)	Test Result (dBm)		
		5745MHz (Ch149)	5785MHz (Ch157)	5825MHz (Ch165)
802.11ac (20MHz)	MCS0	17.22	17.39	17.05
	MCS1	16.67	/	/
	MCS2	16.65	/	/
	MCS3	16.14	/	/
	MCS4	16.11	/	/
	MCS5	15.67	/	/
	MCS6	15.56	/	/
	MCS7	15.32	/	/
	MCS8	14.88	/	/

The data rate MSC0 is selected as worst condition, and the following cases are performed with this condition.

802.11n-HT40 mode

Mode	Data Rate (Index)	Test Result (dBm)	
		5755MHz (Ch151)	5795MHz (Ch159)
802.11n (40MHz)	MCS0	16.36	16.48
	MCS1	15.67	/
	MCS2	15.65	/
	MCS3	15.23	/
	MCS4	15.19	/
	MCS5	14.36	/
	MCS6	14.56	/
	MCS7	14.08	/

The data rate MSC0 is selected as worst condition, and the following cases are performed with this condition.

802.11ac-HT40 mode

Mode	Data Rate (Index)	Test Result (dBm)	
		5755MHz (Ch151)	5795MHz (Ch159)
802.11ac (40MHz)	MCS0	16.40	16.53
	MCS1	15.87	/
	MCS2	15.56	/
	MCS3	15.33	/
	MCS4	15.28	/
	MCS5	14.77	/
	MCS6	14.76	/
	MCS7	14.15	/

	MCS8	12.56	/
--	------	-------	---

The data rate MSC0 is selected as worst condition, and the following cases are performed with this condition.

802.11ac-HT80 mode

Mode	Data Rate (Index)	Test Result (dBm)
		5775MHz (Ch155)
802.11ac (80MHz)	MCS0	16.18
	MCS1	15.22
	MCS2	15.23
	MCS3	14.32
	MCS4	14.33
	MCS5	13.78
	MCS6	13.35
	MCS7	12.40
	MCS8	11.56

The data rate MSC0 is selected as worst condition, and the following cases are performed with this condition.

Duty Cycle

Mode	802.11a	802.11n20	802.11n40	802.11ac20	802.11ac40	802.11ac80
Duty Cycle	98%	99%	98%	99%	98%	98%

Conclusion: PASS

A.3. Peak Power Spectral Density

Measurement Limit:

Standard	Limit
FCC 47 CFR Part 15.407(a)	< 30 dBm/500 kHz

The measurement is made according to ANSI C63.10 and KDB789033 D02

Measurement Uncertainty:

Measurement Uncertainty	0.75dB
-------------------------	--------

Measurement Results:

Mode	Channel	Power Spectral Density (dBm/500kHz)	Conclusion
802.11a	149	4.50	P
	157	4.74	P
	165	4.62	P
802.11ac HT20	149	4.53	P
	157	4.80	P
	165	4.64	P
802.11ac HT40	151	0.81	P
	159	1.02	P
802.11ac HT80	155	-2.66	P

Conclusion: PASS

A.4. Occupied 6dB Bandwidth

Measurement Limit:

Standard	Limit (kHz)
FCC 47 CFR Part 15.407 (e)	≥ 500

The measurement is made according to KDB789033 D02 .

Measurement Uncertainty:

Measurement Uncertainty	60.80Hz
-------------------------	---------

Measurement Result:

Mode	Channel	Occupied 6dB Bandwidth (MHz)		conclusion
		Fig.	Value	
802.11a	149	Fig.1	15.87	P
	157	Fig.2	15.94	P
	165	Fig.3	16.01	P
802.11ac HT20	149	Fig.4	16.25	P
	157	Fig.5	16.24	P
	165	Fig.6	15.60	P
802.11ac HT40	151	Fig.7	36.25	P
	159	Fig.8	35.76	P
802.11ac HT80	155	Fig.9	75.09	P

Conclusion: PASS

Test graphs as below:

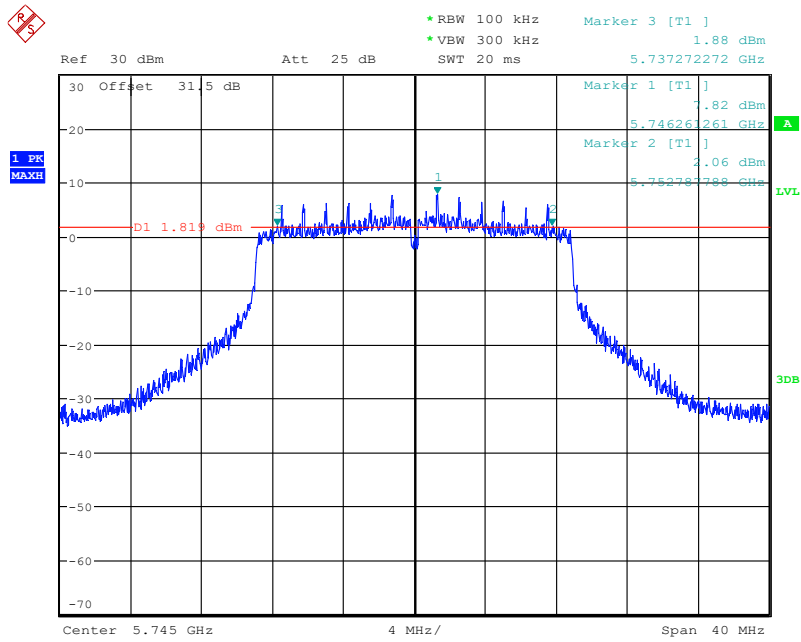

Date: 4.AUG.2023 13:03:19

Fig. 1 Occupied 6dB Bandwidth (802.11a, Ch 149)

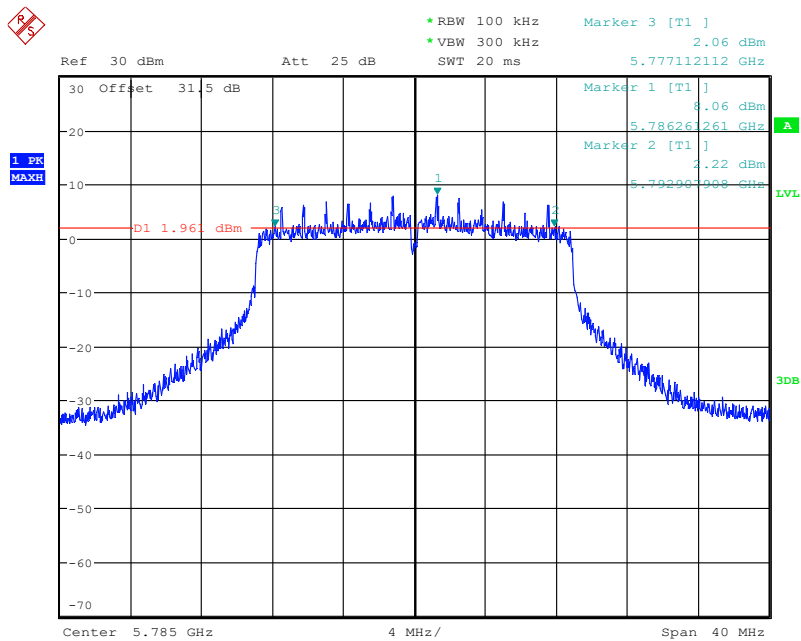

Date: 4.AUG.2023 13:03:57

Fig. 2 Occupied 6dB Bandwidth (802.11a, Ch 157)

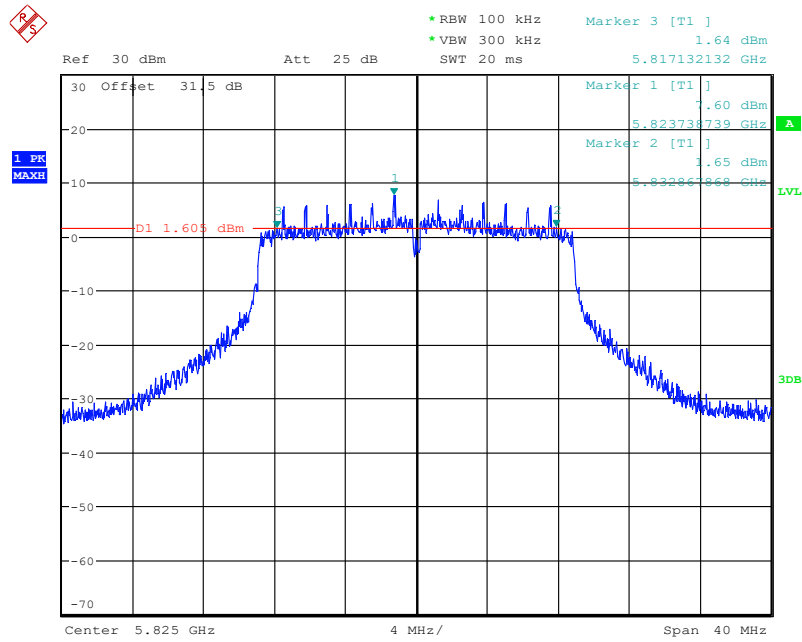

Date: 4.AUG.2023 13:04:35

Fig. 3 Occupied 6dB Bandwidth (802.11a, Ch 165)

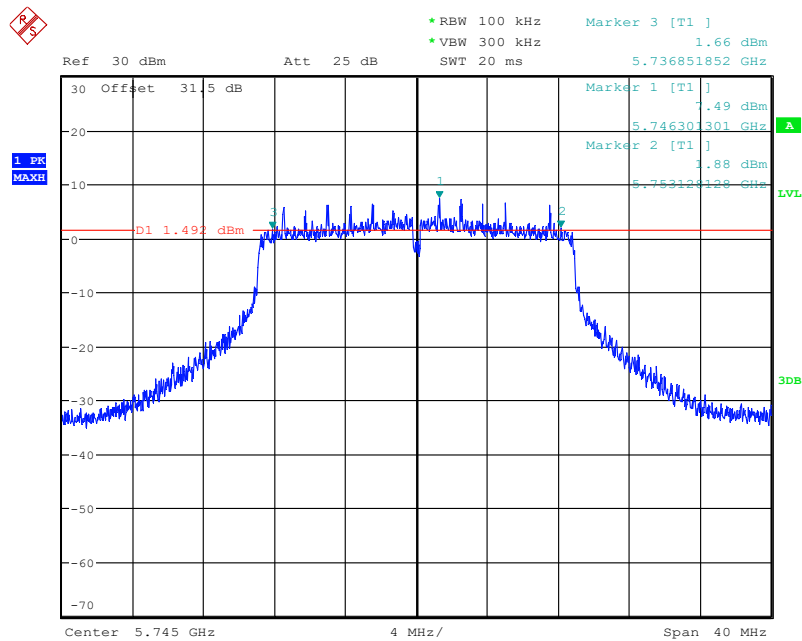

Date: 4.AUG.2023 13:07:22

Fig. 4 Occupied 6dB Bandwidth (802.11ac-HT20, Ch 149)

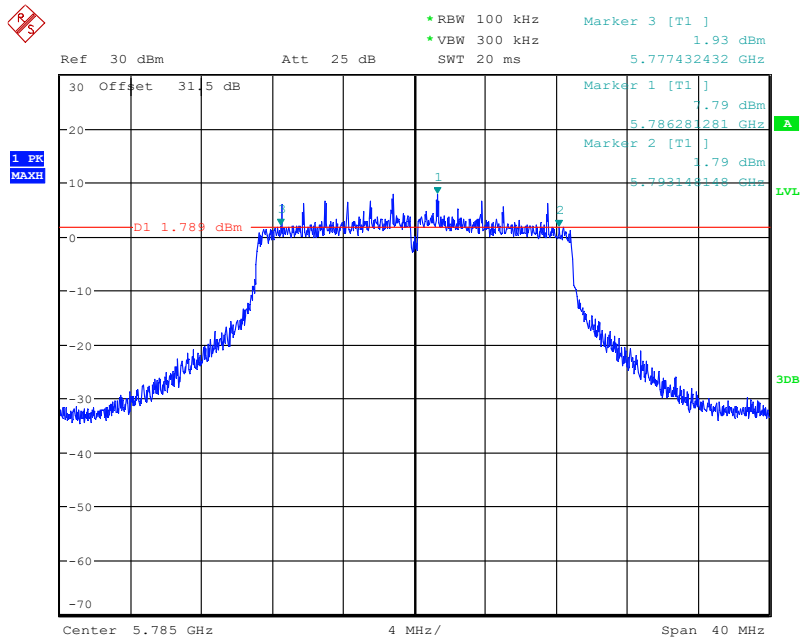

Date: 4.AUG.2023 13:08:00

Fig. 5 Occupied 6dB Bandwidth (802.11ac-HT20, Ch 157)

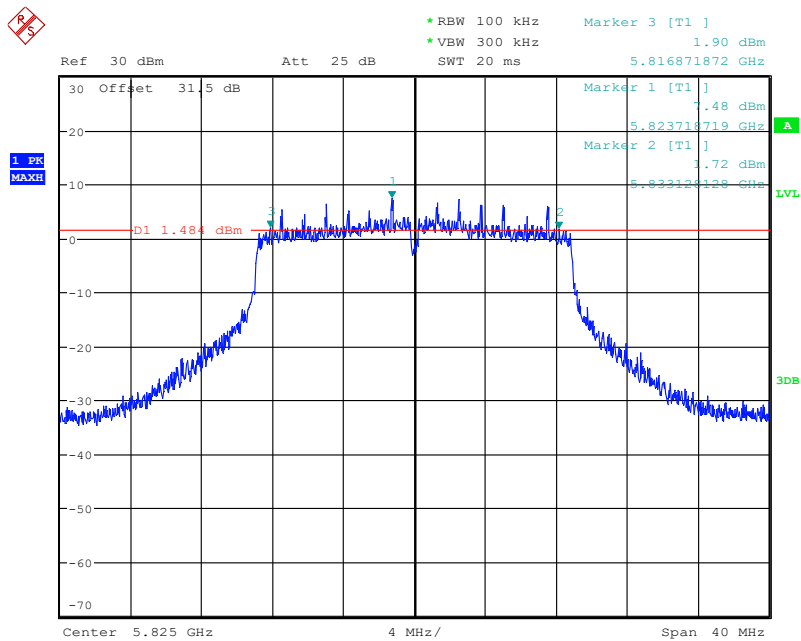

Date: 4.AUG.2023 13:08:39

Fig. 6 Occupied 6dB Bandwidth (802.11ac-HT20, Ch 165)

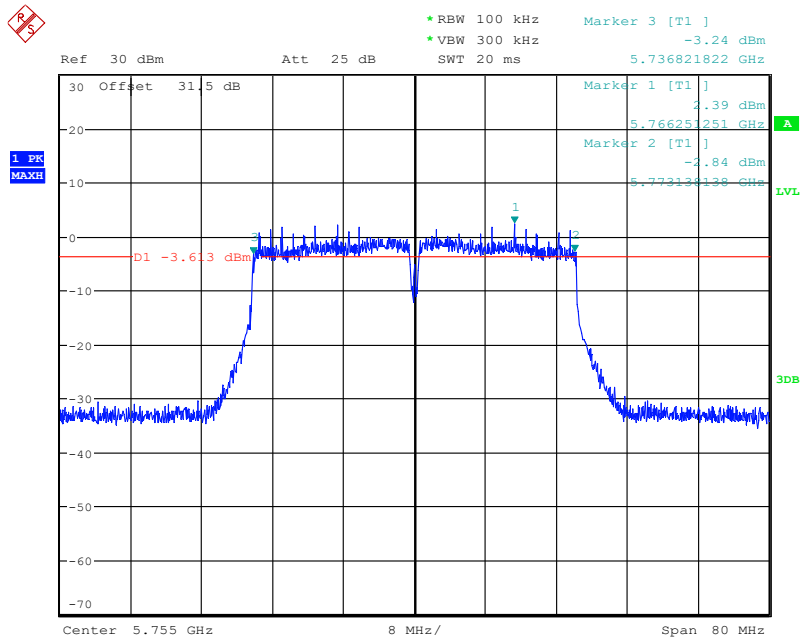

Date: 4.AUG.2023 13:10:43

Fig. 7 Occupied 6dB Bandwidth (802.11ac-HT40, Ch 151)

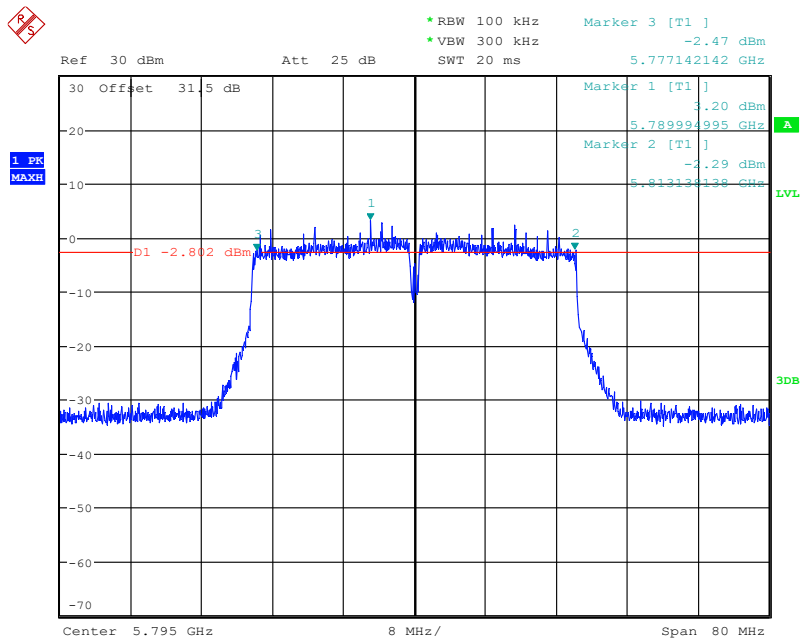

Date: 4.AUG.2023 13:11:21

Fig. 8 Occupied 6dB Bandwidth (802.11ac-HT40, Ch 159)

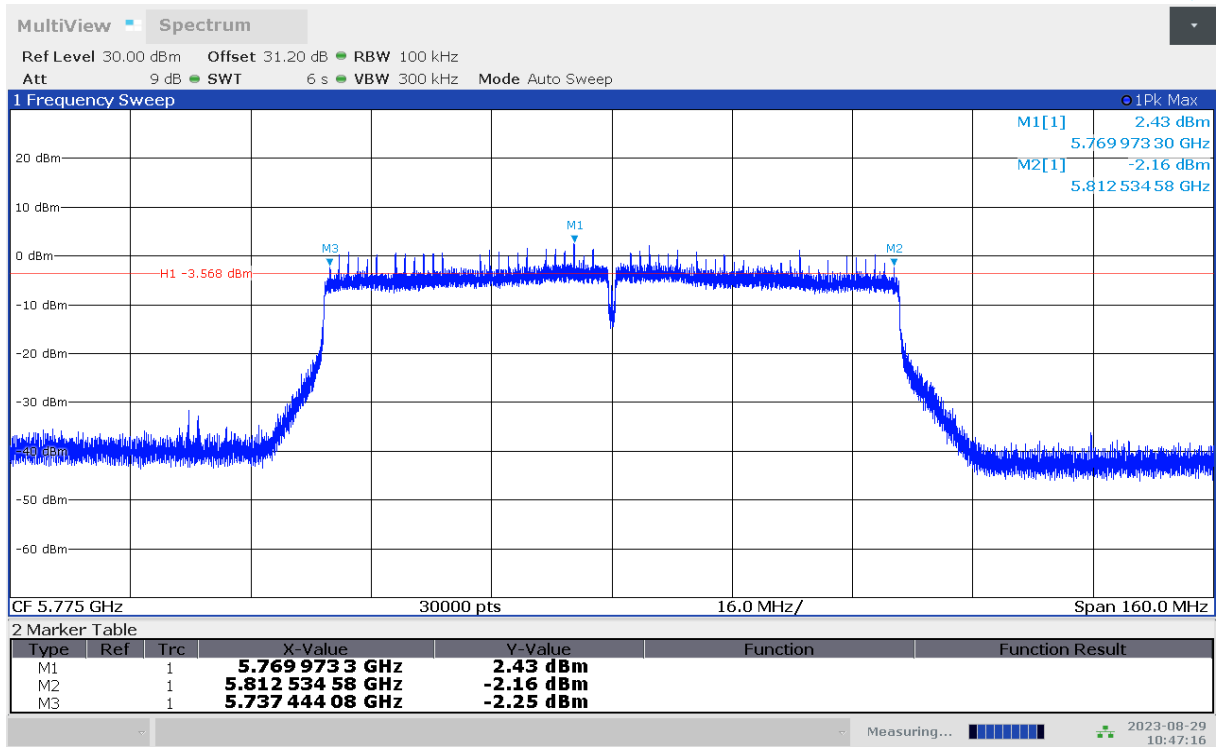

Fig. 9 Occupied 6dB Bandwidth (802.11ac-HT80, Ch 155)

A.5. Transmitter Spurious Emission

Measurement Limit:

Standard	Limit (dBm/MHz)	
FCC 47 CFR Part 15.407	at the band edge	27
	at 5 MHz above or below the band edge	15.6
	at 25 MHz above or below the band edge	10
	at 75 MHz or more above or below the band edge	-27
	Note: Increasing linearly from point to point.	

The measurement is made according to ANSI C63.10 and KDB 789033.

Radiated emissions which fall in the restricted bands, as defined in § 15.205(a), must also comply with the radiated emission limits specified in § 15.209(a) (see § 15.205(c)).

Limit in restricted band:

Frequency (MHz)	Field strength(μ V/m)	Measurement distance (m)
0.009 - 0.490	2400/F(kHz)	300
0.490 - 1.705	24000/F(kHz)	30
1.705 – 30.0	30	30

Frequency of emission (MHz)	Field strength (uV/m)	Field strength (dBuV/m)	Measurement distance (m)
30-88	100	40	3
88-216	150	43.5	3
216-960	200	46	3
Above 960	500	54	3

Set up:

Tabletop devices shall be placed on a nonconducting platform with nominal top surface dimensions 1 m by 1.5 m. For emissions testing at or below 1 GHz, the table height shall be 80 cm above the reference ground plane. For emission measurements above 1 GHz, the table height shall be 1.5 m

The EUT and transmitting antenna shall be centered on the turntable.

Test Procedure

The EUT was placed on a non-conductive table. The measurement antenna was placed at a distance of 3 meters from the EUT. The test is carried out on both vertical and horizontal polarization and only maximization result of both polarizations is kept. During the test, the turntable is rotated 360° and the measurement antenna is moved from 1m to 4m to get the maximization result. This maximization process was repeated with the EUT positioned in each of its three orthogonal orientations.

The receiver references:

Frequency of emission	RBW/VBW	Sweep Time(s)
-----------------------	---------	---------------

(MHz)		
30-1000	100kHz/300kHz	5
1000-7000	1MHz/3MHz	15
7000-18000	1MHz/3MHz	40
18000-26500	1MHz/3MHz	20

Sample Calculations

1. Convert the resultant EIRP level to an equivalent electric field strength using the following relationship:

$$E = \text{EIRP} - 20 \log(D) + 104.77$$

Where:

E is the field strength in dB μ V/m

D is the measurement distance in meters

EIRP is the equivalent isotropically radiated power in dbm

2. The measurement results are obtained as described below:

$$\text{Result} = P_{\text{Mea}} + A_{\text{Rpl}} = P_{\text{Mea}} + \text{Cable Loss} + \text{Antenna Factor}$$

A "reference path loss" is established and the A_{Rpl} is the attenuation of "reference path loss", and including the gain of receive antenna, the gain of the preamplifier, the cable loss.

P_{Mea} is the field strength recorded from the instrument.

Note:

The range of evaluated frequency is from 9 kHz to 40GHz. Measurement value showed here only up to 6 maximum emissions noted.

Measurement Results:
Average Results:
802.11a

Channel 149

Frequency (MHz)	Measurement Result (dBuV/m)	Cable Loss (dB)	Antenna Factor (dB/m)	Receiver Reading (dBuV)	Limit (dBuV/m)	Margin (dB)	Antenna Pol. (H/V)
5390.400	43.63	-23.11	34.50	32.24	54.00	10.37	V
5411.800	43.60	-23.08	34.48	32.20	54.00	10.40	V
7659.500	35.72	-32.07	35.88	31.91	54.00	18.28	H
11490.000	33.17	-31.32	38.19	26.30	54.00	20.83	H
17734.000	38.35	-25.24	41.30	22.29	54.00	15.65	H
17814.500	38.88	-24.96	41.29	22.56	54.00	15.12	H

Channel 157

Frequency (MHz)	Measurement Result (dBuV/m)	Cable Loss (dB)	Antenna Factor (dB/m)	Receiver Reading (dBuV)	Limit (dBuV/m)	Margin (dB)	Antenna Pol. (H/V)
5393.400	43.55	-23.07	34.50	32.12	54.00	10.45	V
5411.200	43.60	-23.07	34.48	32.19	54.00	10.40	V
7713.000	36.14	-32.17	35.80	32.52	54.00	17.86	H
11570.000	33.45	-31.22	38.41	26.26	54.00	20.55	H
17734.000	38.45	-25.24	41.30	22.39	54.00	15.55	V
17812.000	39.09	-24.97	41.29	22.77	54.00	14.91	V

Channel 165

Frequency (MHz)	Measurement Result (dBuV/m)	Cable Loss (dB)	Antenna Factor (dB/m)	Receiver Reading (dBuV)	Limit (dBuV/m)	Margin (dB)	Antenna Pol. (H/V)
5393.600	43.53	-23.07	34.50	32.10	54.00	10.47	V
5411.400	43.47	-23.07	34.48	32.07	54.00	10.53	V
7766.500	36.58	-31.94	35.83	32.69	54.00	17.42	H
11650.000	33.66	-30.93	38.60	25.98	54.00	20.34	V
17732.000	38.53	-25.23	41.30	22.47	54.00	15.47	V
17808.000	39.04	-24.98	41.29	22.73	54.00	14.96	V

802.11n-HT20

Channel 149

Frequency (MHz)	Measurement Result (dBuV/m)	Cable Loss (dB)	Antenna Factor (dB/m)	Receiver Reading (dBuV)	Limit (dBuV/m)	Margin (dB)	Antenna Pol. (H/V)
5395.400	43.59	-23.05	34.50	32.13	54.00	10.41	V
5404.200	43.50	-23.06	34.49	32.07	54.00	10.50	V
7660.000	35.82	-32.08	35.88	32.02	54.00	18.18	V
11490.000	33.11	-31.32	38.19	26.25	54.00	20.89	H
17720.000	38.24	-25.22	41.30	22.16	54.00	15.76	V
17770.500	38.60	-25.12	41.30	22.42	54.00	15.40	V

Channel 157

Frequency (MHz)	Measurement Result (dBuV/m)	Cable Loss (dB)	Antenna Factor (dB/m)	Receiver Reading (dBuV)	Limit (dBuV/m)	Margin (dB)	Antenna Pol. (H/V)
5389.000	43.47	-23.13	34.50	32.10	54.00	10.53	V
5394.000	43.48	-23.07	34.50	32.04	54.00	10.52	V
7713.000	36.27	-32.17	35.80	32.64	54.00	17.73	H
11570.000	33.41	-31.22	38.41	26.21	54.00	20.59	H
17750.000	38.50	-25.19	41.30	22.39	54.00	15.50	H
17831.000	39.02	-24.90	41.27	22.65	54.00	14.98	V

Channel 165

Frequency (MHz)	Measurement Result (dBuV/m)	Cable Loss (dB)	Antenna Factor (dB/m)	Receiver Reading (dBuV)	Limit (dBuV/m)	Margin (dB)	Antenna Pol. (H/V)
5395.400	43.46	-23.05	34.50	32.01	54.00	10.54	V
5415.800	43.46	-23.08	34.47	32.07	54.00	10.54	V
7766.000	36.50	-31.94	35.83	32.62	54.00	17.50	H
11650.000	33.65	-30.93	38.60	25.97	54.00	20.35	H
17733.000	38.26	-25.24	41.30	22.20	54.00	15.74	V
17809.000	38.99	-24.98	41.29	22.68	54.00	15.01	V

802.11n-HT40

Channel 151

Frequency (MHz)	Measurement Result (dBuV/m)	Cable Loss (dB)	Antenna Factor (dB/m)	Receiver Reading (dBuV)	Limit (dBuV/m)	Margin (dB)	Antenna Pol. (H/V)
5382.600	43.58	-23.20	34.50	32.28	54.00	10.42	V
5397.200	43.61	-23.04	34.50	32.15	54.00	10.39	V
7673.000	35.36	-32.16	35.85	31.67	54.00	18.64	V
11510.000	33.23	-31.30	38.23	26.30	54.00	20.77	V
17728.000	38.42	-25.23	41.30	22.35	54.00	15.58	H
17785.000	38.69	-25.07	41.30	22.45	54.00	15.31	H

Channel 159

Frequency (MHz)	Measurement Result (dBuV/m)	Cable Loss (dB)	Antenna Factor (dB/m)	Receiver Reading (dBuV)	Limit (dBuV/m)	Margin (dB)	Antenna Pol. (H/V)
5373.400	43.64	-23.32	34.50	32.46	54.00	10.36	V
5406.400	43.70	-23.06	34.49	32.27	54.00	10.30	V
7726.000	36.05	-32.12	35.80	32.37	54.00	17.95	H
11590.000	33.51	-31.15	38.47	26.19	54.00	20.49	H
17713.500	38.45	-25.20	41.30	22.36	54.00	15.55	H
17737.500	38.41	-25.24	41.30	22.35	54.00	15.59	V

802.11ac-HT20

Channel 149

Frequency (MHz)	Measurement Result (dBuV/m)	Cable Loss (dB)	Antenna Factor (dB/m)	Receiver Reading (dBuV)	Limit (dBuV/m)	Margin (dB)	Antenna Pol. (H/V)
5373.600	43.47	-23.31	34.50	32.29	54.00	10.53	V
5399.400	43.66	-23.05	34.50	32.21	54.00	10.34	V
7659.500	35.75	-32.07	35.88	31.94	54.00	18.25	H
11490.000	33.14	-31.32	38.19	26.27	54.00	20.86	V
17726.500	38.29	-25.23	41.30	22.21	54.00	15.71	H
17806.000	38.98	-24.99	41.29	22.68	54.00	15.02	V

Channel 157

Frequency (MHz)	Measurement Result (dBuV/m)	Cable Loss (dB)	Antenna Factor (dB/m)	Receiver Reading (dBuV)	Limit (dBuV/m)	Margin (dB)	Antenna Pol. (H/V)
5376.600	43.46	-23.28	34.50	32.24	54.00	10.54	V
5393.800	43.60	-23.07	34.50	32.17	54.00	10.40	V
7713.000	36.28	-32.17	35.80	32.65	54.00	17.72	V
11570.000	33.39	-31.22	38.41	26.20	54.00	20.61	V
17724.500	38.42	-25.22	41.30	22.34	54.00	15.58	H
17823.500	39.04	-24.93	41.28	22.69	54.00	14.96	H

Channel 165

Frequency (MHz)	Measurement Result (dBuV/m)	Cable Loss (dB)	Antenna Factor (dB/m)	Receiver Reading (dBuV)	Limit (dBuV/m)	Margin (dB)	Antenna Pol. (H/V)
5396.600	43.65	-23.04	34.50	32.19	54.00	10.35	V
5418.000	43.62	-23.09	34.46	32.24	54.00	10.38	V
7766.500	36.70	-31.94	35.83	32.81	54.00	17.30	H
11650.000	33.79	-30.93	38.60	26.12	54.00	20.21	V
17769.000	38.65	-25.13	41.30	22.47	54.00	15.35	V
17722.000	38.46	-25.22	41.30	22.38	54.00	15.54	V

802.11ac-HT40

Channel 151

Frequency (MHz)	Measurement Result (dBuV/m)	Cable Loss (dB)	Antenna Factor (dB/m)	Receiver Reading (dBuV)	Limit (dBuV/m)	Margin (dB)	Antenna Pol. (H/V)
5402.600	43.69	-23.05	34.49	32.25	54.00	10.31	V
5411.400	43.68	-23.07	34.48	32.28	54.00	10.32	V
7673.000	35.44	-32.16	35.85	31.75	54.00	18.56	H
11510.000	33.39	-31.30	38.23	26.46	54.00	20.61	V
15933.000	39.45	-24.94	40.73	23.65	54.00	14.55	V
17955.500	39.36	-24.72	41.20	22.87	54.00	14.64	V

Channel 159

Frequency (MHz)	Measurement Result (dBuV/m)	Cable Loss (dB)	Antenna Factor (dB/m)	Receiver Reading (dBuV)	Limit (dBuV/m)	Margin (dB)	Antenna Pol. (H/V)
5393.800	43.72	-23.07	34.50	32.29	54.00	10.28	V
5419.400	43.69	-23.09	34.46	32.32	54.00	10.31	V
7726.500	36.16	-32.11	35.80	32.47	54.00	17.84	H
11590.000	33.68	-31.15	38.47	26.35	54.00	20.32	H
15900.000	39.47	-24.81	40.70	23.59	54.00	14.53	V
17974.500	39.54	-24.77	41.20	23.10	54.00	14.46	V

802.11ac-HT80

Channel 155

Frequency (MHz)	Measurement Result (dBuV/m)	Cable Loss (dB)	Antenna Factor (dB/m)	Receiver Reading (dBuV)	Limit (dBuV/m)	Margin (dB)	Antenna Pol. (H/V)
5405.400	43.76	-23.06	34.49	32.34	54.00	10.24	V
5420.200	43.74	-23.09	34.46	32.38	54.00	10.26	V
7699.500	34.46	-32.23	35.80	30.89	54.00	19.54	H
11500.000	33.41	-31.31	38.20	26.53	54.00	20.59	H
15908.500	39.41	-24.84	40.71	23.54	54.00	14.59	V
17990.500	39.69	-24.81	41.20	23.30	54.00	14.31	V

Peak Results:
802.11a

Channel 149

Frequency (MHz)	Measurement Result (dBuV/m)	Cable Loss (dB)	Antenna Factor (dB/m)	Receiver Reading (dBuV)	Limit (dBuV/m)	Margin (dB)	Antenna Pol. (H/V)
5650.151	57.79	-22.87	34.70	45.96	68.31	10.52	V
5650.647	57.70	-22.87	34.70	45.86	68.68	10.98	V
7659.500	44.91	-32.07	35.88	41.10	74.00	29.09	H
11490.000	45.10	-31.32	38.19	38.24	74.00	28.90	H
17235.000	51.41	-24.80	41.26	34.95	68.30	16.88	V
17443.500	52.91	-24.68	41.20	36.39	68.30	15.38	V

Channel 157

Frequency (MHz)	Measurement Result (dBuV/m)	Cable Loss (dB)	Antenna Factor (dB/m)	Receiver Reading (dBuV)	Limit (dBuV/m)	Margin (dB)	Antenna Pol. (H/V)
5722.200	63.58	-22.73	34.84	51.47	68.30	4.72	H
5842.600	64.41	-23.09	35.10	52.39	68.30	3.89	V
7713.000	44.90	-32.17	35.80	41.28	74.00	29.10	H
11570.000	45.39	-31.22	38.41	38.20	74.00	28.61	V
17355.000	51.20	-24.60	41.20	34.59	68.30	17.10	H
17571.000	53.39	-24.98	41.20	37.17	68.30	14.91	H

Channel 165

Frequency (MHz)	Measurement Result (dBuV/m)	Cable Loss (dB)	Antenna Factor (dB/m)	Receiver Reading (dBuV)	Limit (dBuV/m)	Margin (dB)	Antenna Pol. (H/V)
5923.598	57.50	-23.24	35.25	45.49	69.24	11.74	H
5924.324	57.81	-23.24	35.25	45.80	68.70	10.89	H
7766.500	45.62	-31.94	35.83	41.73	68.30	22.67	V
11650.000	45.85	-30.93	38.60	38.18	74.00	28.15	V
17475.000	50.91	-24.75	41.20	34.46	68.30	17.39	V
17612.500	52.87	-25.04	41.21	36.70	68.30	15.43	H

802.11n-HT20

Channel 149

Frequency (MHz)	Measurement Result (dBuV/m)	Cable Loss (dB)	Antenna Factor (dB/m)	Receiver Reading (dBuV)	Limit (dBuV/m)	Margin (dB)	Antenna Pol. (H/V)
5651.610	58.01	-22.87	34.70	46.17	69.39	11.38	V
5652.710	57.93	-22.86	34.71	46.09	70.21	12.27	V
11490.000	44.87	-31.32	38.19	38.00	74.00	29.13	H
17235.000	51.21	-24.80	41.26	34.75	68.30	17.09	V
17286.500	53.56	-24.71	41.21	37.07	68.30	14.74	H
17321.000	53.58	-24.65	41.20	37.03	68.30	14.72	V

Channel 157

Frequency (MHz)	Measurement Result (dBuV/m)	Cable Loss (dB)	Antenna Factor (dB/m)	Receiver Reading (dBuV)	Limit (dBuV/m)	Margin (dB)	Antenna Pol. (H/V)
5718.600	60.99	-22.73	34.84	48.89	68.30	7.31	H
5859.800	60.94	-23.15	35.14	48.95	68.30	7.36	H
7713.000	44.89	-32.17	35.80	41.26	74.00	29.11	V
11570.000	45.80	-31.22	38.41	38.61	74.00	28.20	V
17355.000	52.30	-24.60	41.20	35.70	68.30	16.00	V
17518.000	53.52	-24.86	41.20	37.18	68.30	14.78	H

Channel 165

Frequency (MHz)	Measurement Result (dBuV/m)	Cable Loss (dB)	Antenna Factor (dB/m)	Receiver Reading (dBuV)	Limit (dBuV/m)	Margin (dB)	Antenna Pol. (H/V)
5924.375	56.62	-23.24	35.25	44.60	68.66	12.05	H
5924.648	56.93	-23.23	35.25	44.92	68.46	11.53	H
7766.500	46.38	-31.94	35.83	42.49	68.30	21.91	H
11650.000	46.63	-30.93	38.60	38.96	74.00	27.37	V
17475.000	50.32	-24.75	41.20	33.87	68.30	17.98	V
17513.500	53.24	-24.85	41.20	36.89	68.30	15.06	V

802.11n-HT40

Channel 151

Frequency (MHz)	Measurement Result (dBuV/m)	Cable Loss (dB)	Antenna Factor (dB/m)	Receiver Reading (dBuV)	Limit (dBuV/m)	Margin (dB)	Antenna Pol. (H/V)
5651.287	57.92	-22.87	34.70	46.08	69.15	11.23	H
5652.322	57.40	-22.86	34.70	45.56	69.92	12.51	H
11510.000	45.12	-31.30	38.23	38.19	74.00	28.88	H
17265.000	50.78	-24.75	41.23	34.30	68.30	17.52	H
17377.000	53.72	-24.56	41.20	37.08	68.30	14.58	V
17534.500	53.07	-24.90	41.20	36.77	68.30	15.23	V

Channel 159

Frequency (MHz)	Measurement Result (dBuV/m)	Cable Loss (dB)	Antenna Factor (dB/m)	Receiver Reading (dBuV)	Limit (dBuV/m)	Margin (dB)	Antenna Pol. (H/V)
5923.850	56.86	-23.24	35.25	44.85	69.05	12.19	V
5924.231	57.23	-23.24	35.25	45.21	68.77	11.54	H
7726.500	45.19	-32.11	35.80	41.50	74.00	28.81	H
11590.000	45.52	-31.15	38.47	38.20	74.00	28.48	H
17385.000	50.92	-24.54	41.20	34.27	68.30	17.38	V
17619.000	52.56	-25.06	41.22	36.39	68.30	15.74	V

802.11ac-HT20

Channel 149

Frequency (MHz)	Measurement Result (dBuV/m)	Cable Loss (dB)	Antenna Factor (dB/m)	Receiver Reading (dBuV)	Limit (dBuV/m)	Margin (dB)	Antenna Pol. (H/V)
5650.388	57.69	-22.87	34.70	45.86	68.49	10.80	H
5650.913	57.16	-22.87	34.70	45.33	68.88	11.72	H
11490.000	45.39	-31.32	38.19	38.52	74.00	28.61	H
17235.000	50.43	-24.80	41.26	33.97	68.30	17.87	H
17408.500	52.99	-24.59	41.20	36.39	68.30	15.31	H
17493.000	53.25	-24.80	41.20	36.85	68.30	15.05	H

Channel 157

Frequency (MHz)	Measurement Result (dBuV/m)	Cable Loss (dB)	Antenna Factor (dB/m)	Receiver Reading (dBuV)	Limit (dBuV/m)	Margin (dB)	Antenna Pol. (H/V)
5719.800	62.81	-22.73	34.84	50.71	68.30	5.49	H
5855.800	62.30	-23.14	35.12	50.31	68.30	6.00	H
7713.000	45.79	-32.17	35.80	42.16	74.00	28.21	V
11570.000	45.07	-31.22	38.41	37.88	74.00	28.93	H
17355.000	51.80	-24.60	41.20	35.19	68.30	16.50	H
17527.500	52.93	-24.88	41.20	36.61	68.30	15.37	H

Channel 165

Frequency (MHz)	Measurement Result (dBuV/m)	Cable Loss (dB)	Antenna Factor (dB/m)	Receiver Reading (dBuV)	Limit (dBuV/m)	Margin (dB)	Antenna Pol. (H/V)
5924.339	57.99	-23.24	35.25	45.98	68.69	10.70	H
5924.518	58.12	-23.23	35.25	46.10	68.56	10.44	V
7766.500	45.97	-31.94	35.83	42.08	74.00	28.03	V
11650.000	45.29	-30.93	38.60	37.61	74.00	28.71	H
17475.000	51.04	-24.75	41.20	34.59	68.30	17.26	H
17589.000	52.69	-25.01	41.20	36.50	68.30	15.61	H

802.11ac-HT40

Channel 151

Frequency (MHz)	Measurement Result (dBuV/m)	Cable Loss (dB)	Antenna Factor (dB/m)	Receiver Reading (dBuV)	Limit (dBuV/m)	Margin (dB)	Antenna Pol. (H/V)
5650.503	58.76	-22.87	34.70	46.93	68.57	9.81	V
5651.071	58.23	-22.87	34.70	46.40	68.99	10.76	V
7673.000	45.20	-32.16	35.85	41.51	74.00	28.80	H
11510.000	45.68	-31.30	38.23	38.75	74.00	28.32	V
17265.000	51.91	-24.75	41.23	35.43	68.30	16.39	V
17405.500	53.81	-24.58	41.20	37.19	68.30	14.49	H

Channel 159

Frequency (MHz)	Measurement Result (dBuV/m)	Cable Loss (dB)	Antenna Factor (dB/m)	Receiver Reading (dBuV)	Limit (dBuV/m)	Margin (dB)	Antenna Pol. (H/V)
5923.275	57.63	-23.24	35.25	45.62	68.30	10.67	V
5923.742	58.18	-23.24	35.25	46.16	68.30	10.12	H
7726.000	45.51	-32.12	35.80	41.83	74.00	28.49	H
11590.000	46.24	-31.15	38.47	38.91	74.00	27.76	H
17385.000	51.78	-24.54	41.20	35.12	68.30	16.52	H
17638.500	52.86	-25.09	41.24	36.71	68.30	15.44	H

802.11ac-HT80

Channel 155

Frequency (MHz)	Measurement Result (dBuV/m)	Cable Loss (dB)	Antenna Factor (dB/m)	Receiver Reading (dBuV)	Limit (dBuV/m)	Margin (dB)	Antenna Pol. (H/V)
5651.394	59.63	-22.87	34.70	47.79	69.23	9.60	H
5651.905	59.10	-22.86	34.70	47.26	69.61	10.51	V
7700.000	44.43	-32.23	35.80	40.86	74.00	29.57	H
11550.000	45.10	-31.26	38.35	38.01	74.00	28.90	V
5923.584	58.01	-23.24	35.25	45.99	69.25	11.24	H
5923.972	58.76	-23.24	35.25	46.74	68.96	10.21	V

Conclusion: PASS

Note:

1. The spurious emission above 18G is noise only.
2. All emissions below 30MHz are more than 20 dB below the limit

A.6. Band Edges Compliance

A6.1 Band Edges - Radiated

Measurement Limit:

Standard	Limit (dBm/MHz)	
FCC 47 CFR Part 15.407	at the band edge	27
	at 5 MHz above or below the band edge	15.6
	at 25 MHz above or below the band edge	10
	at 75 MHz or more above or below the band edge	-27
	Note: increasing linearly from point to point.	

Set up:

Tabletop devices shall be placed on a nonconducting platform with nominal top surface dimensions 1 m by 1.5 m and the table height shall be 1.5 m.

The EUT and transmitting antenna shall be centered on the turntable.

Test Procedure

The EUT was placed on a non-conductive table. The measurement antenna was placed at a distance of 3 meters from the EUT. The test is carried out on both vertical and horizontal polarization and only maximization result of both polarizations is kept. During the test, the turntable is rotated 360° and the measurement antenna is moved from 1m to 4m to get the maximization result. This maximization process was repeated with the EUT positioned in each of its three orthogonal orientations.

The receiver references:

Sweep frequency from 30 MHz to 1GHz, RBW = 100 kHz, VBW = 300 kHz;

Sweep frequency from 1 GHz to 26GHz, RBW = 1MHz, VBW = 3MHz

Sample Calculations

Convert the resultant EIRP level to an equivalent electric field strength using the following relationship:

$$E = \text{EIRP} - 20 \log(D) + 104.77 \quad \text{Where:}$$

E is the field strength in dB μ V/m

D is the measurement distance in meters

EIRP is the equivalent isotropically radiated power in dbm

Measurement Result:

Mode	Channel	Test Results	Conclusion
802.11a	5745 MHz	Fig.10	P
	5825 MHz	Fig.11	P
802.11n HT20	5745 MHz	Fig.12	P
	5825 MHz	Fig.13	P
802.11n HT40	5755 MHz	Fig.14	P
	5795 MHz	Fig.15	P
802.11ac HT20	5745 MHz	Fig.16	P
	5825 MHz	Fig.17	P
802.11ac HT40	5755 MHz	Fig.18	P
	5795 MHz	Fig.19	P
802.11ac HT80	5775 MHz	Fig.20 Fig.21	P

Conclusion: PASS

Test graphs as below:

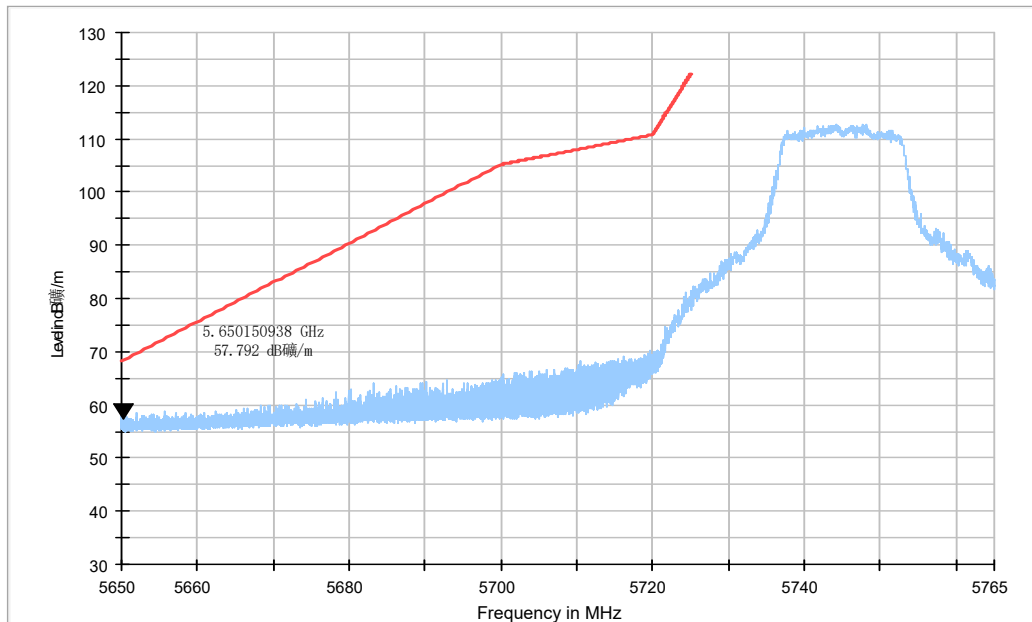

Fig. 10 Band Edges (802.11a Ch149,5745MHz)

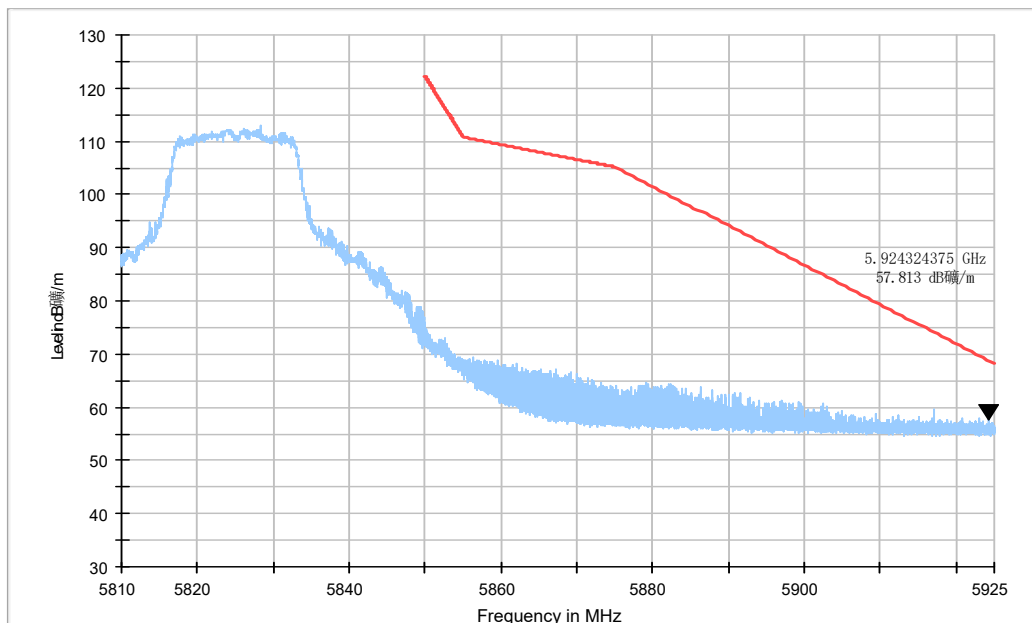

Fig. 11 Band Edges (802.11a Ch165, 5825MHz)

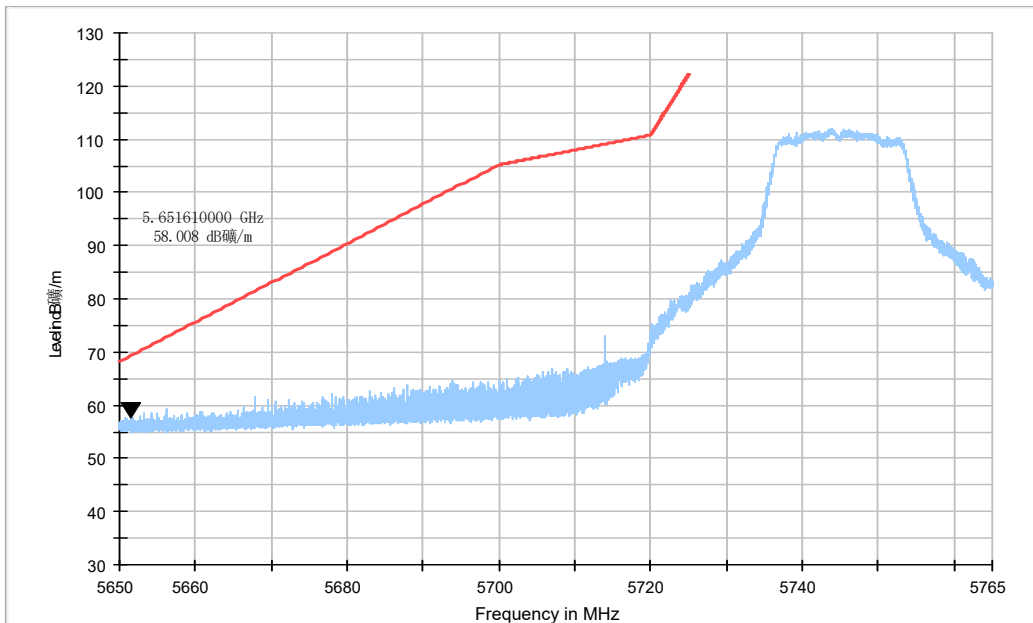

Fig. 12 Band Edges (802.11n-HT20 Ch149, 5745MHz)

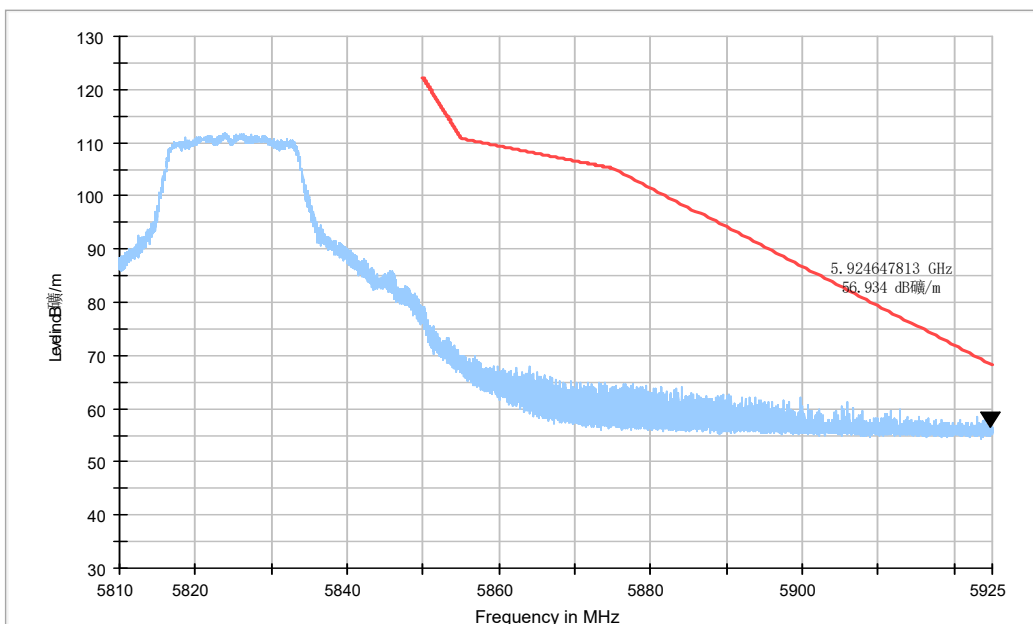

Fig. 13 Band Edges (802.11n-HT20 Ch165, 5825MHz)

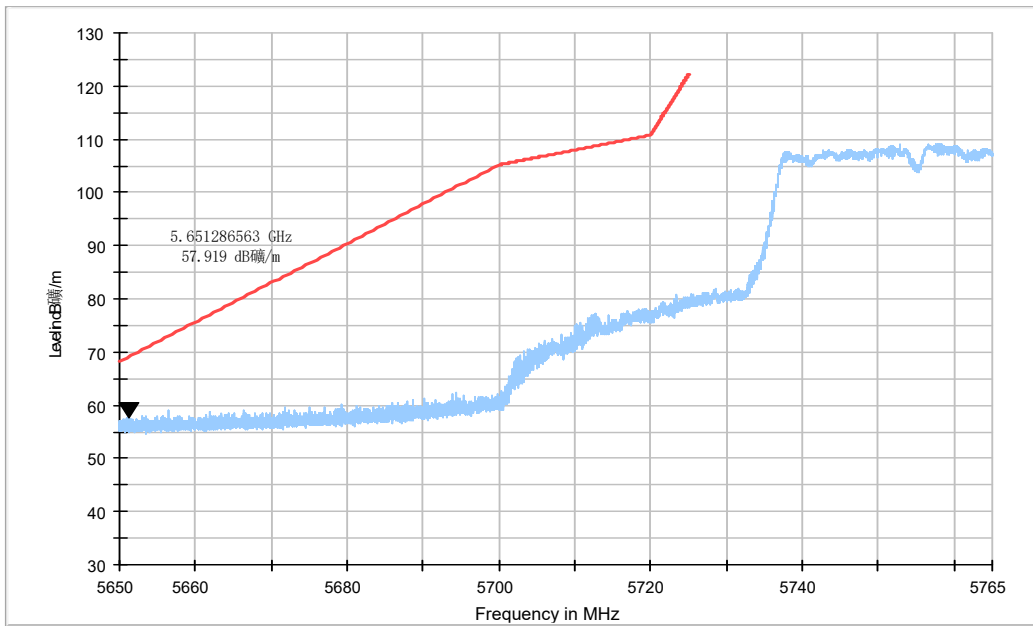

Fig. 14 Band Edges (802.11n-HT40 Ch151, 5755MHz)

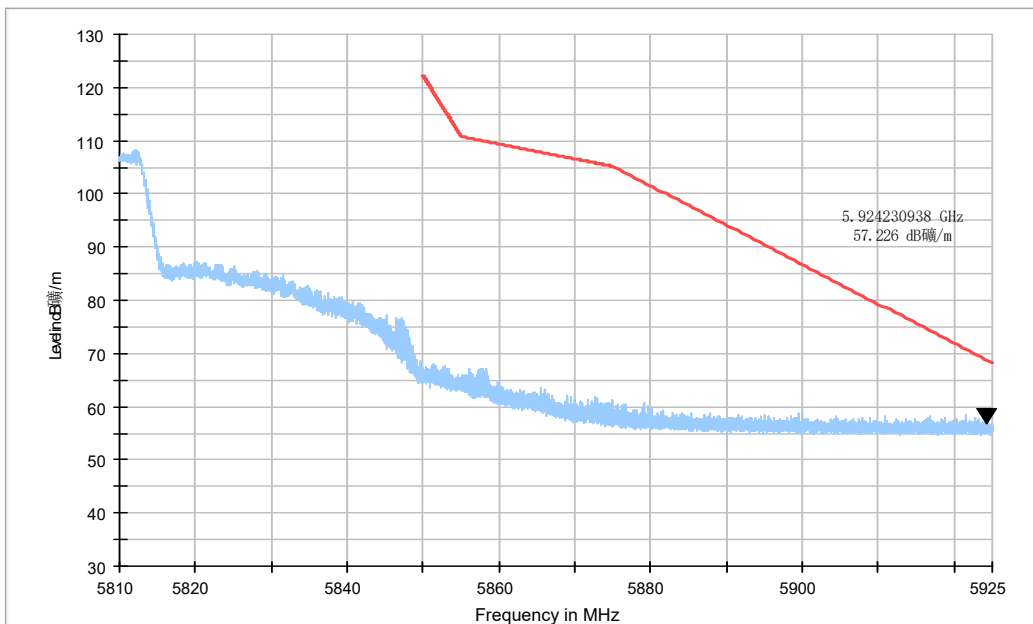

Fig. 15 Band Edges (802.11n-HT40 Ch159, 5795MHz)

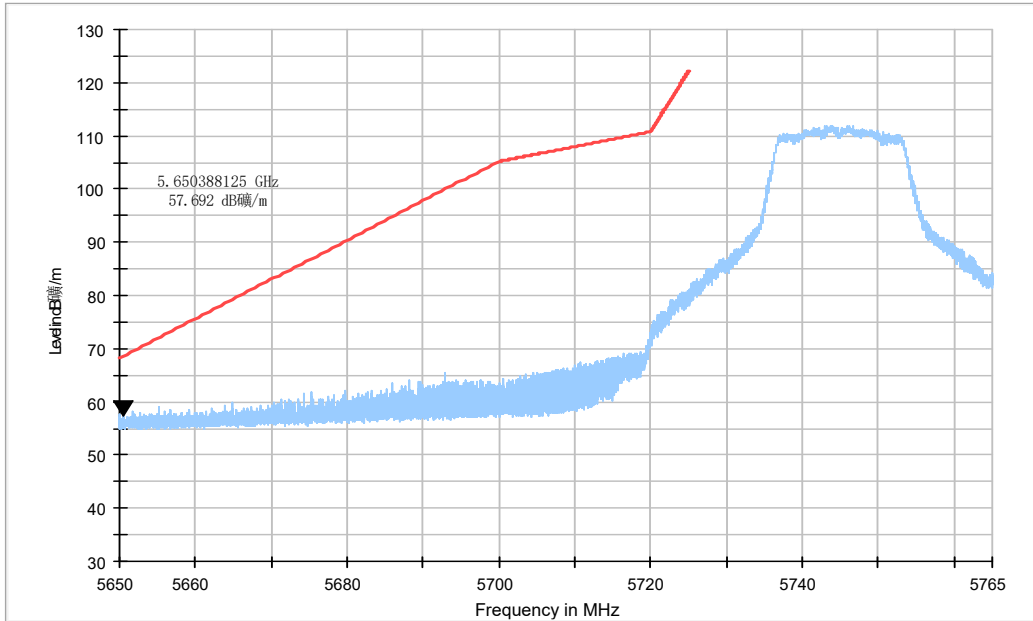

Fig. 16 Band Edges (802.11ac-HT20 Ch149, 5745MHz)

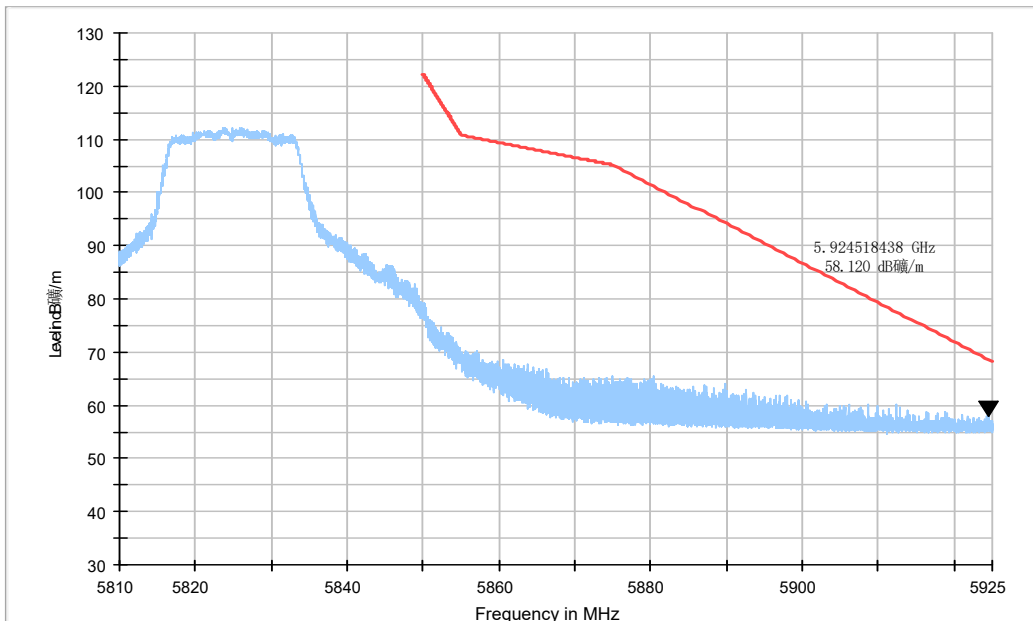

Fig. 17 Band Edges (802.11ac-HT20 Ch165, 5825MHz)

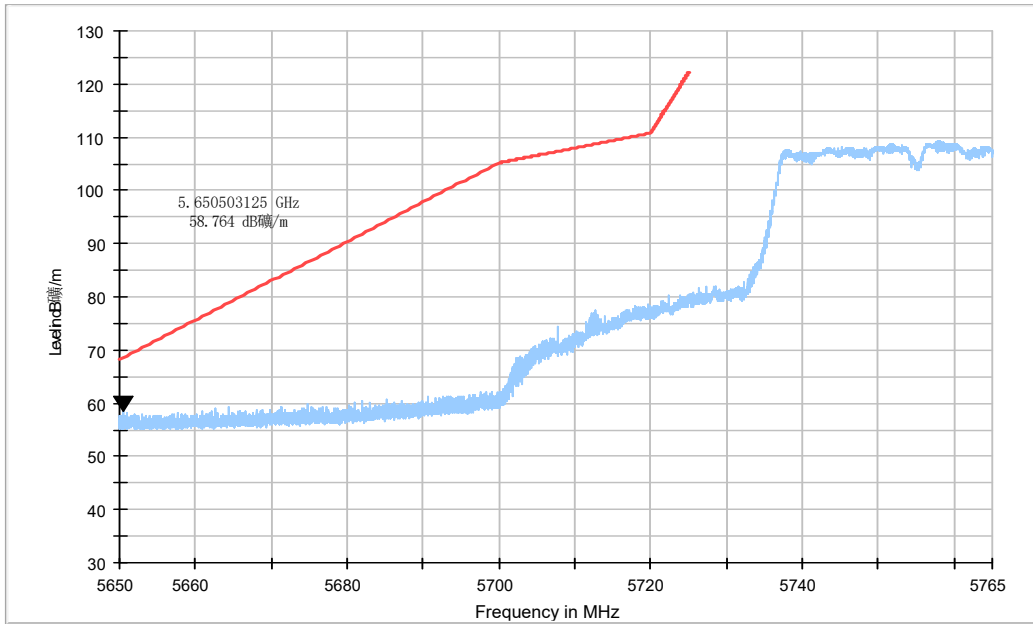

Fig. 18 Band Edges (802.11ac-HT40 Ch151, 5755MHz)

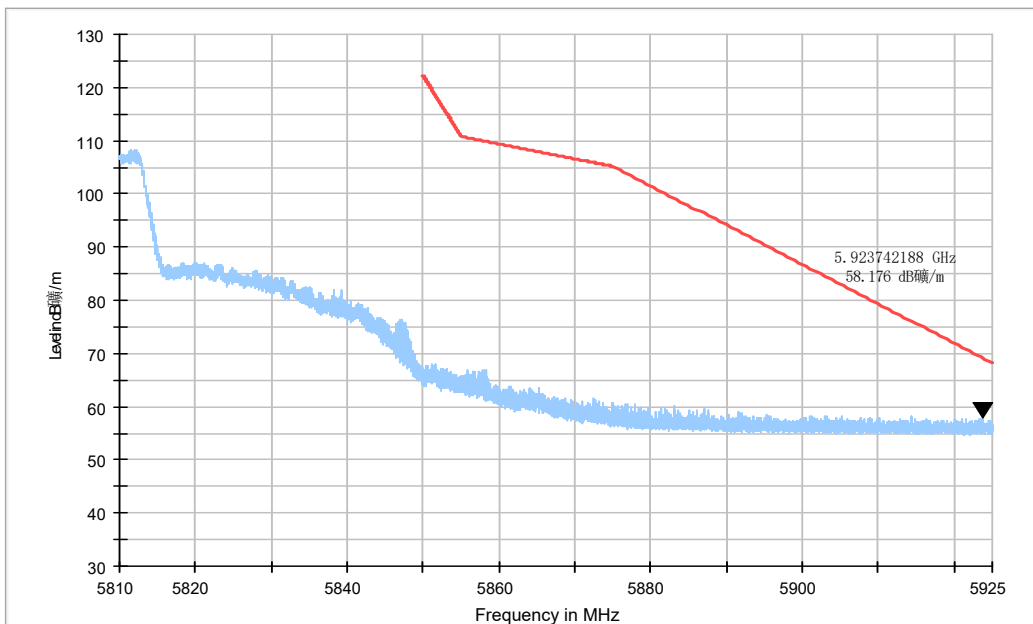

Fig. 19 Band Edges (802.11ac-HT40 Ch159, 5795MHz)

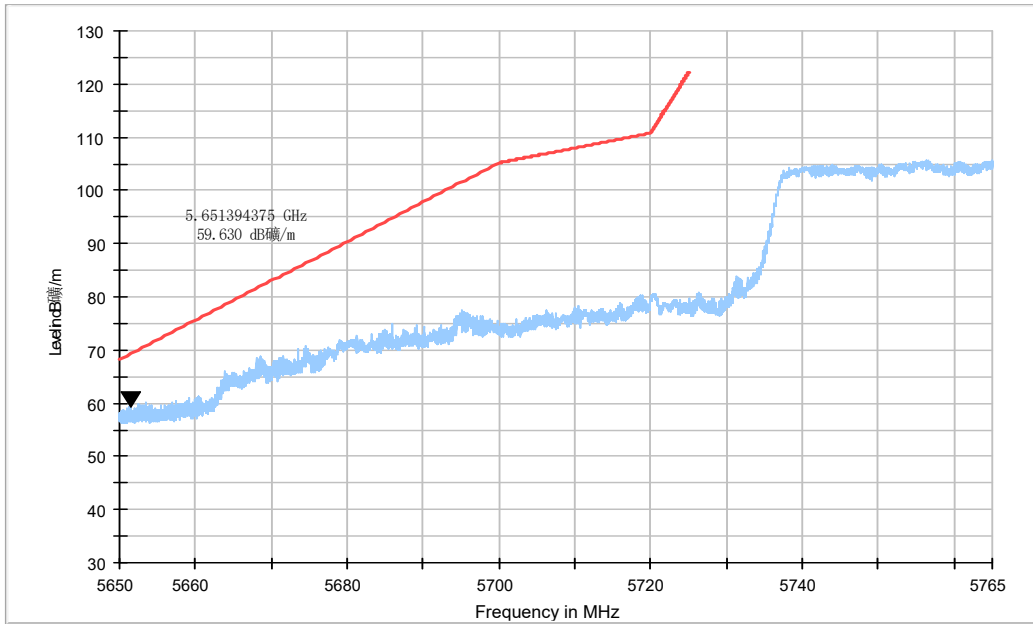

Fig. 20 Band Edges (802.11ac-HT80 Ch155, 5775MHz)

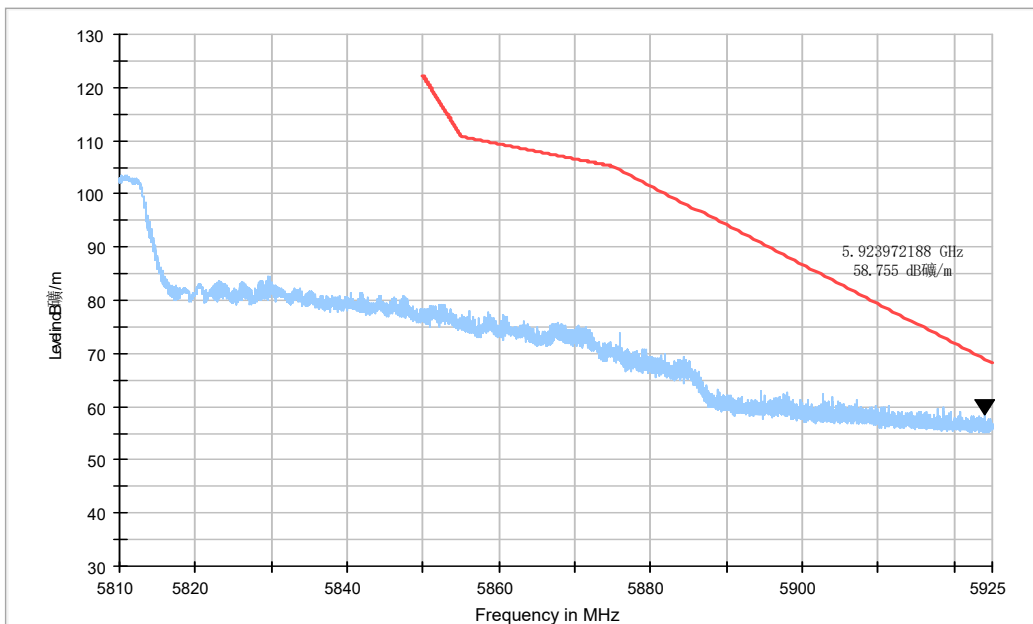

Fig. 21 Band Edges (802.11ac-HT80 Ch155, 5775MHz)

A.7. AC Powerline Conducted Emission

Summary

All AC line conducted spurious emissions are measured with a receiver connected to a grounded LISN while the EUT is operating at its maximum duty cycle, at maximum power, and at the appropriate frequencies. All data rates and modes were investigated for conducted spurious emissions. Only the conducted emissions of the configuration that produced the worst case emissions are reported in this section

Method of Measurement:

See Clause 6.2 of ANSI C63.10 specifically.

See Clause 4 and Clause 5 of ANSI C63.10 generally.

The conducted emissions from the AC port of the EUT are measured in a shielding room. The EUT is connected to a Line Impedance Stabilization Network (LISN). An overview sweep with peak detection was performed. The measurements were performed with a quasi-peak detector and if required, an average detector.

The conducted emission measurements were made with the following detector of the test receiver: Quasi-Peak / Average Detector.

The measurement bandwidth is:

Frequency of Emission (MHz)	RBW/IF bandwidth
0.15-30	9kHz

Test Condition:

Voltage (V)	Frequency (Hz)
120	60

Measurement Setup

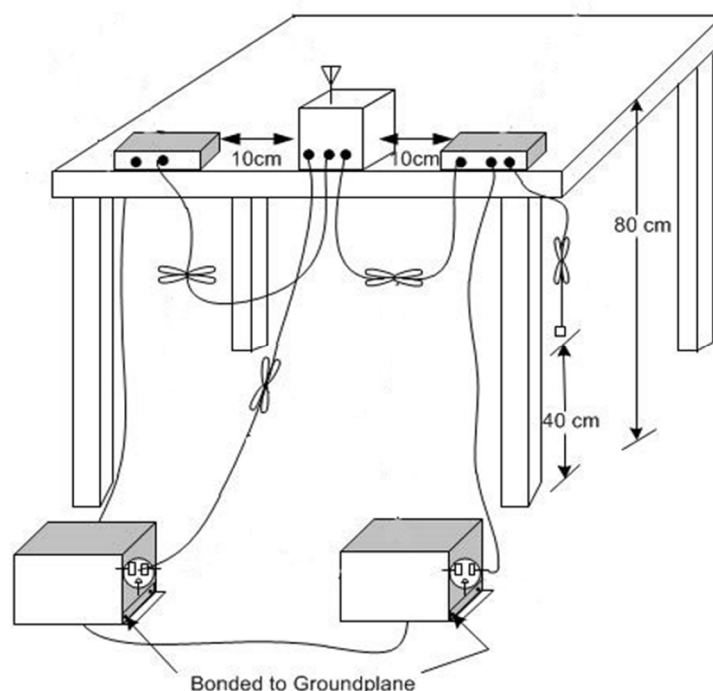

Measurement Result and limit:

WLAN (Quasi-peak Limit)

Frequency range (MHz)	Quasi-peak Limit (dB μ V)	Result (dB μ V)		Conclusion
		With charger		
		802.11a	Idle	
0.15 to 0.5	66 to 56	Fig.22	Fig.23	P
0.5 to 5	56			
5 to 30	60			

NOTE: The limit decreases linearly with the logarithm of the frequency in the range 0.15 MHz to 0.5 MHz.

WLAN (Average Limit)

Frequency range (MHz)	Average Limit (dB μ V)	Result (dB μ V)		Conclusion
		With charger		
		802.11a	Idle	
0.15 to 0.5	56 to 46	Fig.22	Fig.23	P
0.5 to 5	46			
5 to 30	50			

NOTE: The limit decreases linearly with the logarithm of the frequency in the range 0.15 MHz to 0.5 MHz.

Conclusion: PASS

Test graphs as below:

Traffic:

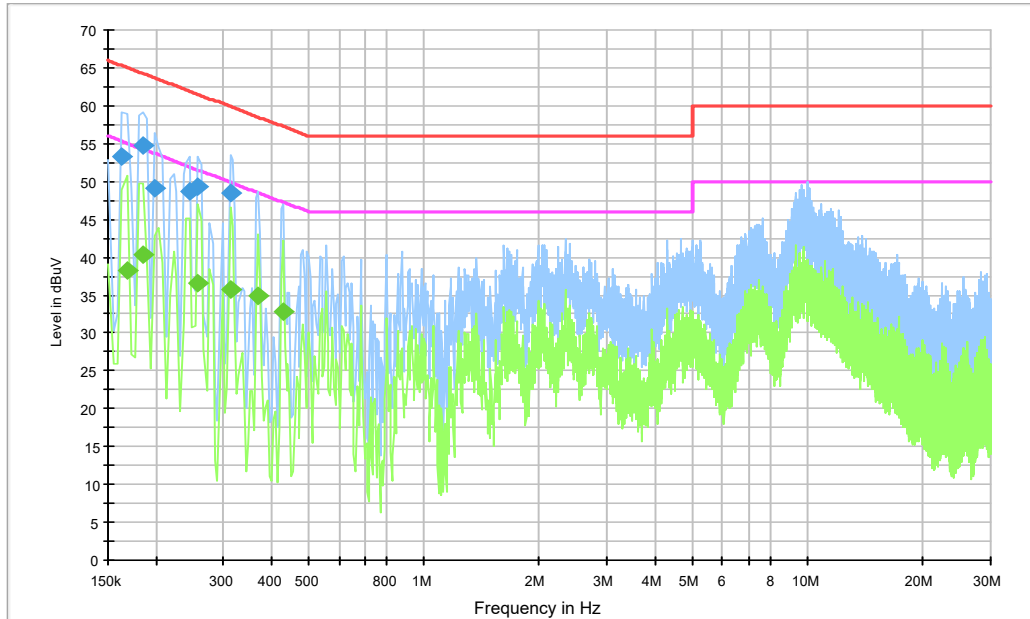

Fig.22 AC Power line Conducted Emission-802.11a

Note1: The graphic result above is the maximum of the measurements for both phase line and neutral line.

Final Result 1

Frequency (MHz)	QuasiPeak (dB μ V)	Meas. Time (ms)	Bandwidth (kHz)	Filter	Line	Corr. (dB)	Margin (dB)	Limit (dB μ V)
0.163500	53.3	2000.0	9.000	Off	N	19.5	12.0	65.3
0.186000	54.7	2000.0	9.000	Off	L1	19.5	9.5	64.2
0.199500	49.2	2000.0	9.000	Off	N	19.4	14.5	63.6
0.244500	48.7	2000.0	9.000	Off	L1	19.5	13.2	61.9
0.258000	49.3	2000.0	9.000	Off	N	19.4	12.2	61.5
0.312000	48.4	2000.0	9.000	Off	N	19.5	11.5	59.9

Final Result 2

Frequency (MHz)	Average (dB μ V)	Meas. Time (ms)	Bandwidth (kHz)	Filter	Line	Corr. (dB)	Margin (dB)	Limit (dB μ V)
0.168000	38.1	2000.0	9.000	Off	N	19.5	16.9	55.1
0.186000	40.4	2000.0	9.000	Off	N	19.5	13.8	54.2
0.258000	36.5	2000.0	9.000	Off	N	19.4	15.0	51.5
0.312000	35.7	2000.0	9.000	Off	N	19.5	14.2	49.9
0.370500	34.9	2000.0	9.000	Off	N	19.5	13.6	48.5
0.429000	32.7	2000.0	9.000	Off	N	19.5	14.6	47.3

Idle:

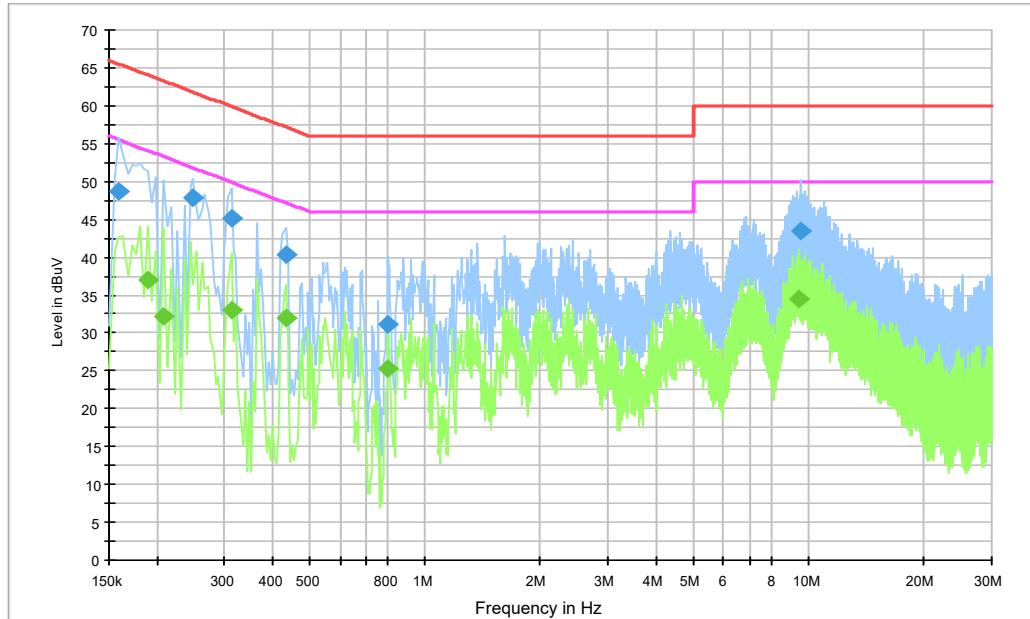

Fig.23 AC Power line Conducted Emission-Idle

Note1: The graphic result above is the maximum of the measurements for both phase line and neutral line.

Final Result 1

Frequency (MHz)	QuasiPeak (dB μ V)	Meas. Time (ms)	Bandwidth (kHz)	Filter	Line	Corr. (dB)	Margin (dB)	Limit (dB μ V)
0.159000	48.7	2000.0	9.000	Off	N	19.5	16.9	65.5
0.249000	47.8	2000.0	9.000	Off	N	19.4	14.0	61.8
0.312000	45.2	2000.0	9.000	Off	N	19.5	14.7	59.9
0.433500	40.3	2000.0	9.000	Off	N	19.5	16.9	57.2
0.802500	31.2	2000.0	9.000	Off	N	19.5	24.8	56.0
9.501000	43.4	2000.0	9.000	Off	N	19.7	16.6	60.0

Final Result 2

Frequency (MHz)	Average (dB μ V)	Meas. Time (ms)	Bandwidth (kHz)	Filter	Line	Corr. (dB)	Margin (dB)	Limit (dB μ V)
0.190500	37.1	2000.0	9.000	Off	N	19.5	17.0	54.0
0.208500	32.2	2000.0	9.000	Off	L1	19.4	21.1	53.3
0.312000	33.0	2000.0	9.000	Off	N	19.5	16.9	49.9
0.433500	32.0	2000.0	9.000	Off	N	19.5	15.1	47.2
0.802500	25.3	2000.0	9.000	Off	L1	19.5	20.7	46.0
9.388500	34.5	2000.0	9.000	Off	L1	19.7	15.5	50.0

ANNEX B: EUT parameters

Disclaimer: The antenna gain provided by the client may affect the validity of the measurement results in this report, and the client shall bear the impact and consequences arising therefrom.

ANNEX C: Accreditation Certificate



Accredited Laboratory

A2LA has accredited

TELECOMMUNICATION TECHNOLOGY LABS, CAICT
Beijing, People's Republic of China

for technical competence in the field of
Electrical Testing

This laboratory is accredited in accordance with the recognized International Standard ISO/IEC 17025:2017 General requirements for the competence of testing and calibration laboratories. This accreditation demonstrates technical competence for a defined scope and the operation of a laboratory quality management system (refer to joint ISO-ILAC-IAF Communiqué dated April 2017).



Presented this 26th day of June 2023.



Mr. Trace McInturf, Vice President, Accreditation Services
For the Accreditation Council
Certificate Number 7049.01
Valid to July 31, 2024

For the tests to which this accreditation applies, please refer to the laboratory's Electrical Scope of Accreditation.

*** END OF REPORT BODY ***