

Type and shape of antenna	IFA Antenna
Directional characteristics	Omni-directional
Deflection Characteristics of Antenna	Linear
Type of connection with transmitter	antenna shrapnel
Manufacturer	Huizhou Speed Wireless Technology Co., LTD Kunshan Innowave Communication Technology Co., LTD
Measuring Organization	Huizhou Speed Wireless Technology Co., LTD Kunshan Innowave Communication Technology Co., LTD

1.EUT Reference Setup

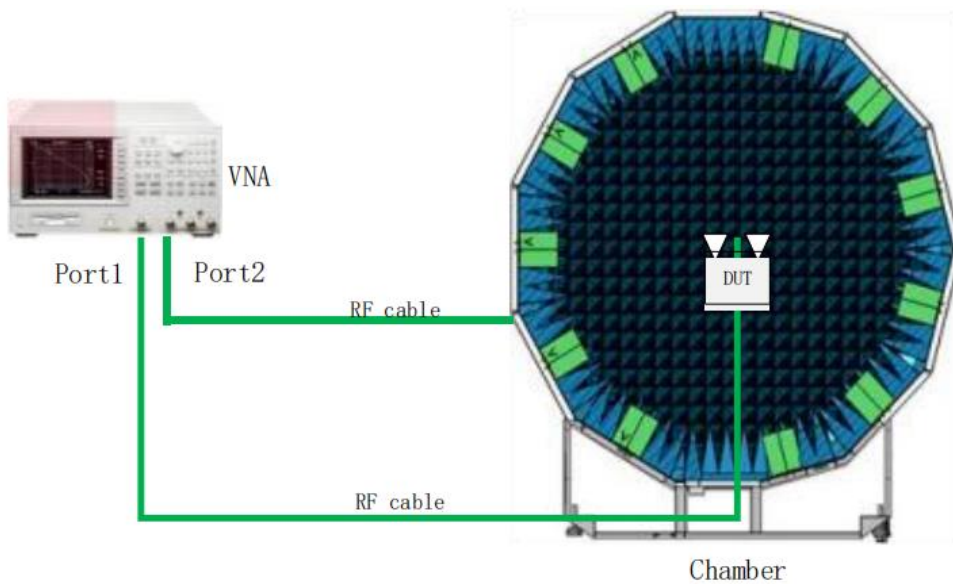

Tester	Fujunfei/XieQing
Actual date of testing	2024-07-31
Test description	Use an anechoic chamber to measure the radiation pattern and antenna gain. The GTS laboratory operates at 0.6-5.9GHz. The chamber's reflection level in the range of 0.6GHz to 5.9 GHz is typically ≤ 25 dB. Standard dipoles are used to calibrate for path loss and magnetic ring lines are used to suppress feeder emissions, so we can measure antenna gain.

Test Equipment List

Name of test equipment	Model	Manufacturer	Cal.Due Date	Calibtation Interval
Pattern Measurement Software	General Test	Ray Zone 1800	NA	NA
Network Analyzer	Agilent	E5071B	2025-05-09	One year

2. Antenna distribution

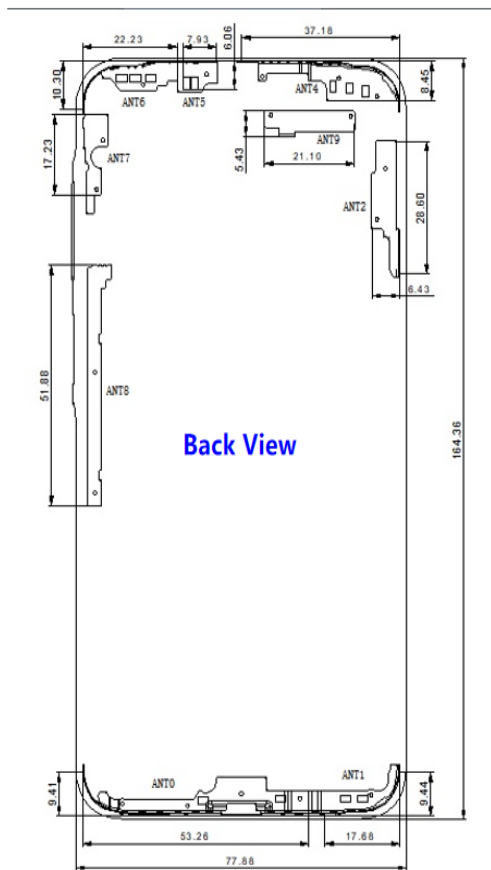

ANT		Single Band
ANT0	TX&RX	GSM 850/900, WCDMA B5/8 Single Band: LTE B5/8/12/17/20/26/28, NR n5/8/26/28 DL CA: LTE B5/7/8/12/17/20/26/28/38/40/41, NR n5/7/8/26/28/40 UL CA: LTE B8/20, NR n28 NSA: LTE B5/7/8/12/20/26/28/38/40/41, NR n5/8/26/28
	RX	LTE B7/38/40/41 NR n7/40/41
ANT1	TX&RX	GSM 1800/1900, WCDMA B1/2/4 Single Band: LTE B2/4/66, NR n66 DL CA: LTE B1/2/3/4/66, NR n1/3/66 UL CA: LTE B1/3 NSA: LTE B1/2/3/4/66
	RX	LTE B1/3 NR n1/3
ANT2	RX	LTE B1/3/4/7/38/41 NR n1/3/7/41/77/78
ANT4	TX&RX	Single Band: LTE B1/3/7/38/40/41, NR n1/3/7/40/41 DL CA: LTE B1/7/40/41, NR n3/41 UL CA: LTE B1/3/7, CA_3C/70/38C/40C, NR n41 NSA: LTE B1/2/3/4/7/20/38/40/41/66, NR n1/3/7/40/41/66
	RX	GSM 850/900/1800/1900, WCDMA B1/2/4/5/8 LTE B1/2/3/4/5/7/8/12/17/20/26/28/38/40/41/66 NR n1/3/5/7/8/26/28/40/41/66
ANT5	TX&RX	Single Band: NR n77/78 DL CA: NR n77/78 NSA: NR n77/78
ANT6	TX&RX	WiFi 2.4G/5G BT
	RX	GPS
ANT7	RX	LTE B1/3/4/7/38/41 NR n1/3/7/41/77/78
ANT8	RX	ENDC B20-n28:LTE B20 DRX/NR N28 DRX
ANT9	RX	NR n77/78

3. Antenna Pattern

ANT0+1

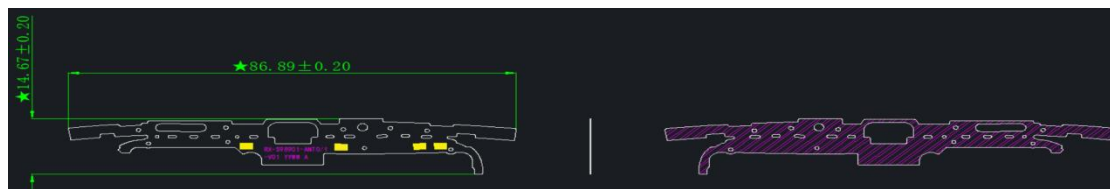

Front

Back

ANT2

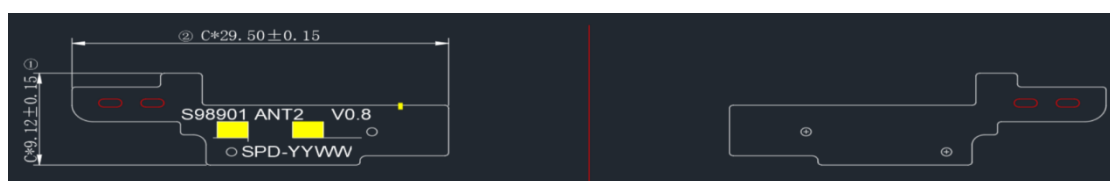

Front

Back

ANT4

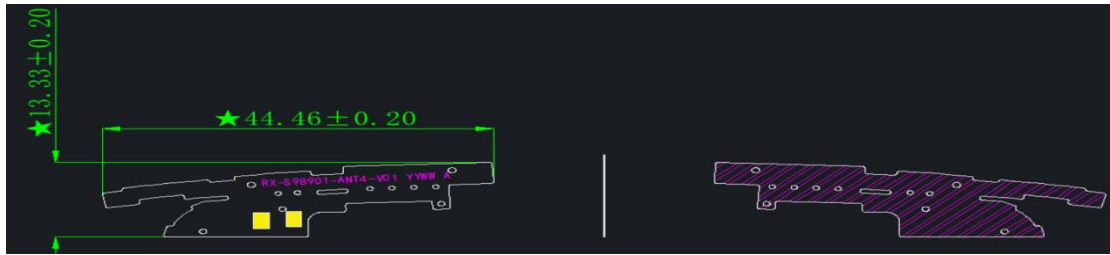

Front

Back

ANT5+6

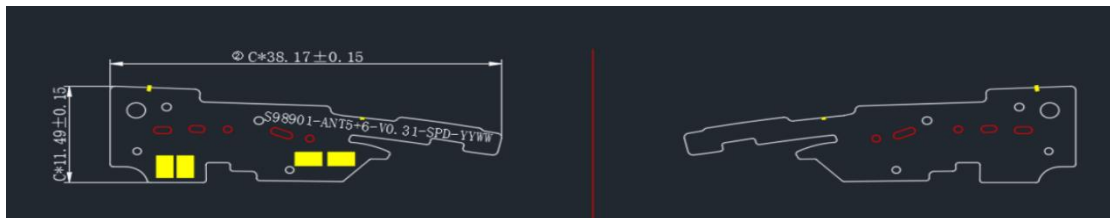

Front

Back

ANT7

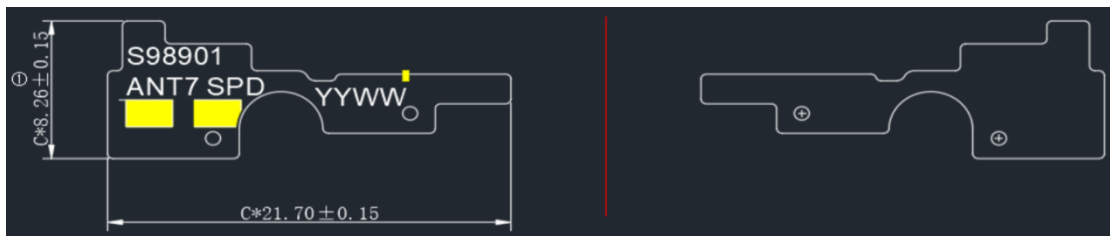

Front

Back

ANT8

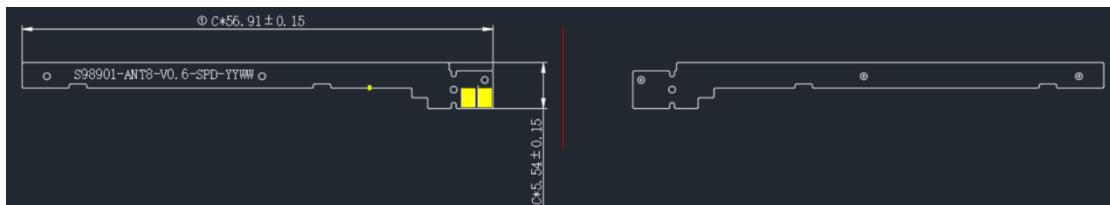

Front

Back

ANT9

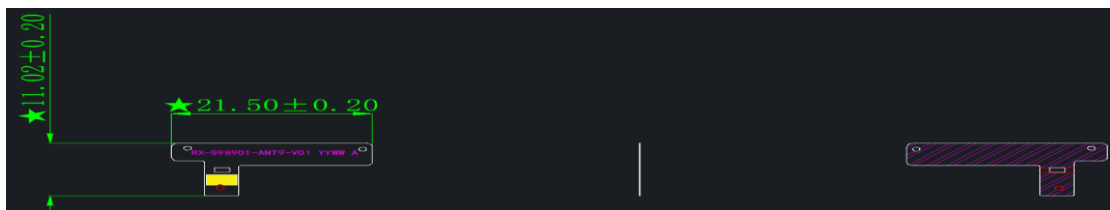

Front

Back

4. Antenna Gain

	Test band	Gain(ANT0)	Gain(ANT1)	Gain(ANT2)	Gain(ANT4)	Gain(ANT7)	Gain(ANT8)
GSM	B5(850)	-1.5	/	/	-2.3	/	/
	B8(900)	-1.4	/	/	-3.1	/	/
	B3(1800)	/	0.3	/	0.8	/	/
	B2(1900)	/	0.4	/	0.3	/	/
WCDMA	B1(W2100)	/	-0.5	/	-0.2	/	/
	B2(W1900)	/	0.4	/	0.3	/	/
	B4(W1700)	/	0.5	/	0.2	/	/
	B5(W850)	-1.5	/	/	-2.3	/	/
	B8(W900)	-1.4	/	/	-3.1	/	/
LTE	B1	/	0.5	-6.4	0.2	-3.8	/
	B2	/	0.4	/	0.3	/	/
	B3	/	0.3	-7.8	0.8	-4.3	/
	B4	/	0.5	-6.4	0.2	-3.8	/
	B5	-1.5	/	/	-2.3	/	/
	B7	0.5	/	-3.3	0.1	-1.1	/
	B8	-1.4	/	/	-3.1	/	/
	B12	-2.0	/	/	-3.7	/	/
	B17	-2.0	/	/	-3.7	/	/
	B20	-1.7	/	/	-3.8	/	-7.1
	B26	-1.5	/	/	-2.3	/	/
	B28	-2.0	/	/	-3.3	/	/
	B38	-0.5	/	-3.3	-0.1	-1.1	/
	B40	0.3	/	/	0.6	/	/
B41	0.5	/	-3.3	0.1	-1.1	/	
B66	/	0.5	/	0.2	/	/	

	Test band	Gain(ANT0)	Gain(ANT1)	Gain(ANT2)	Gain(ANT4)	Gain(ANT7)	Gain(ANT8)
NR	N1	/	0.5	-6.4	0.2	-3.8	/
	N3	/	0.3	-7.8	0.8	-4.3	/
	N5	-1.5	/	/	-2.3	/	/
	N7	0.5	/	-3.3	0.1	-1.1	/
	N8	-1.4	/	/	-3.1	/	/
	N26	-1.5	/	/	-2.3	/	/
	N28	-2.0	/	/	-3.3	/	-7.1
	N40	0.3	/	/	0.6	/	/
	N41	0.5	/	-3.3	0.1	-1.1	/
N66	/	0.5	/	0.2	/	/	

	Test band	Gain(ANT2)	Gain(ANT5)	Gain(ANT7)	Gain(ANT9)
NR	N77	-1.5	-0.5	-2.0	-3.3
	N78	-1.5	-0.5	-2.0	-3.3

	Test band	Gain(ANT6)
WIFI	2.4G	-1.9
BT	BT	-1.9
WIFI	5G	-2.0
GPS	GPS	0.6

5.3D map

ANTO

700MHz

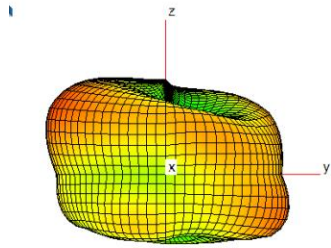

750MHz

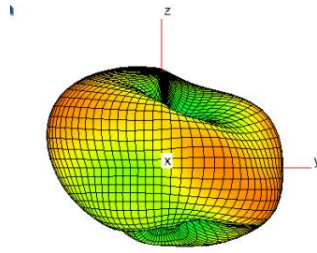

790MHz

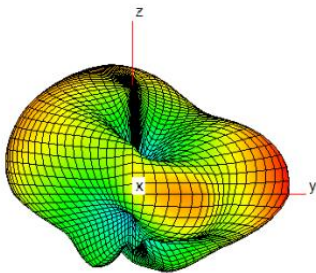

800MHz

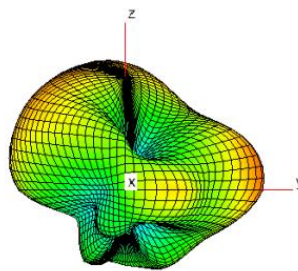

820MHz

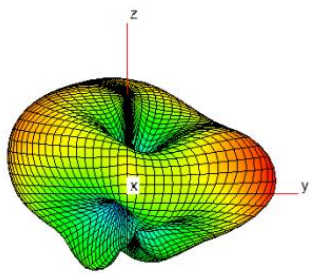

860MHz

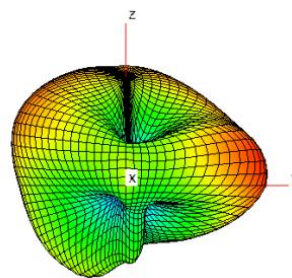

880MHz

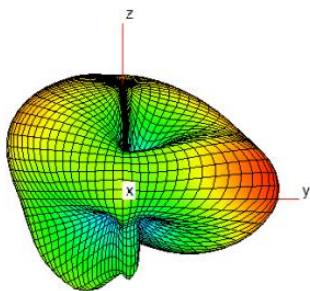

960MHz

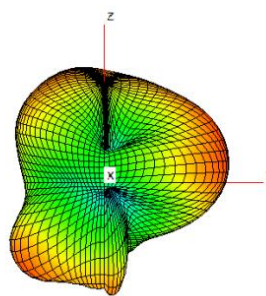

2300MHz

2400MHz

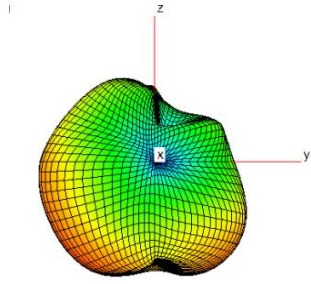

2500MHz

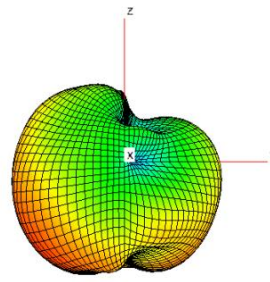

2700MHz

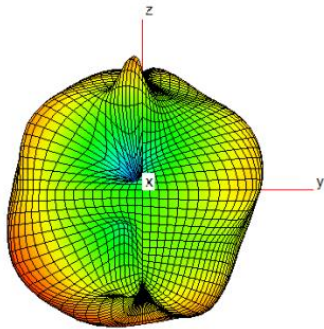

ANT1

1710MHz

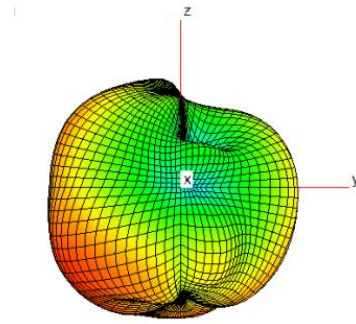

1850MHz

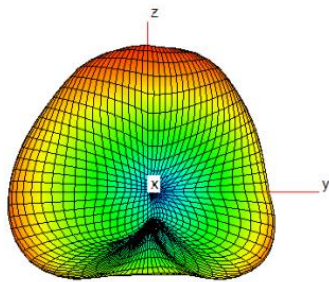

1880MHz

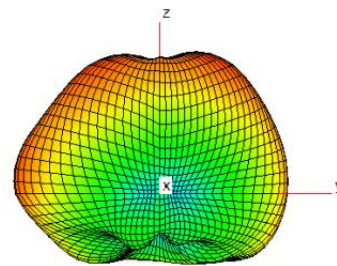

1920MHz

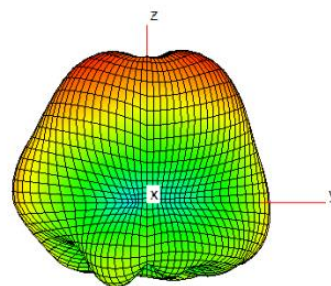
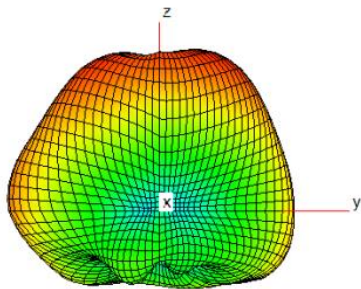

1990MHz

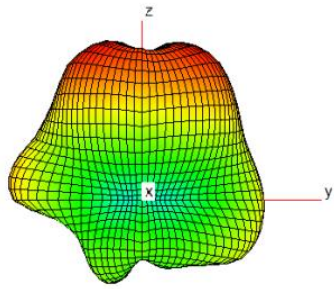

2200MHz

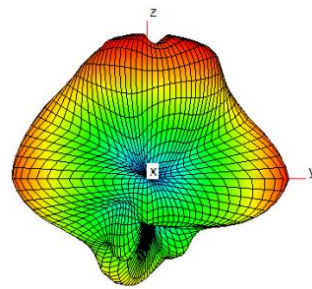

ANT2

1805MHz

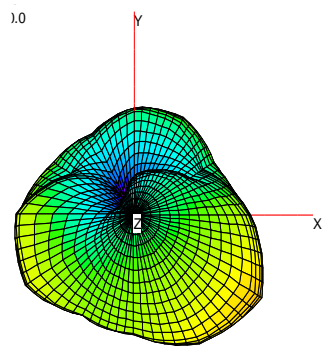

1880MHz

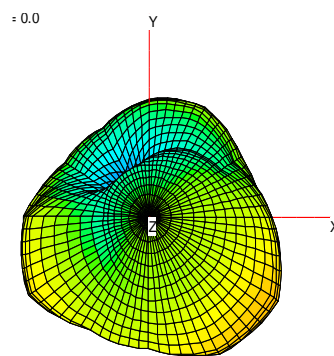

1930MHz

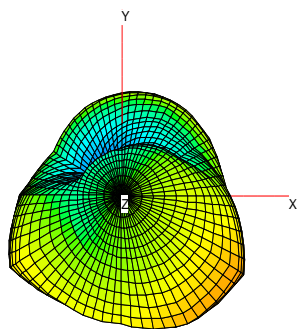

1990MHz

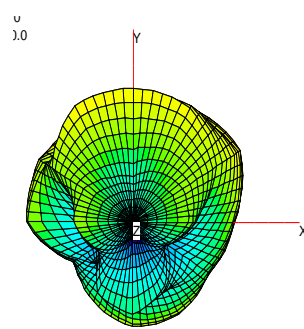

2110MHz

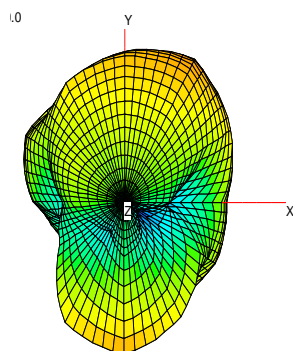

2200MHz

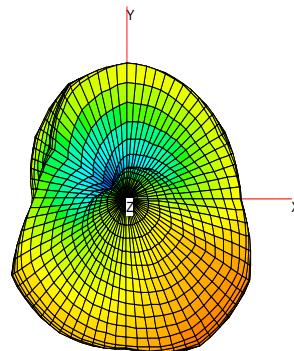

2300MHz

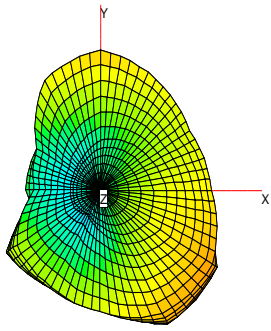

2500MHz

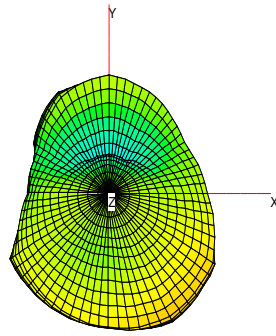

2580MHz

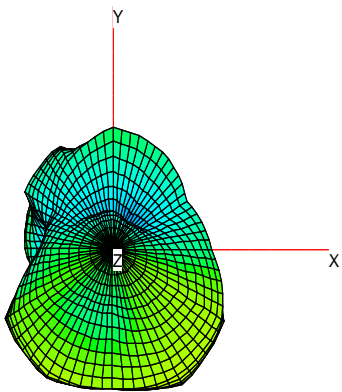

2690MHz

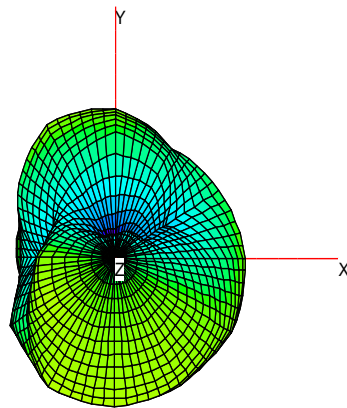

3300MHz

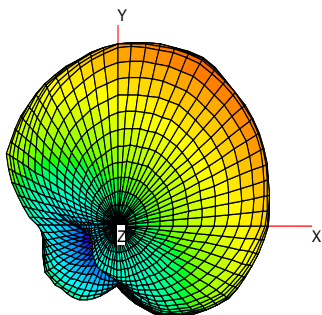

4200MHz

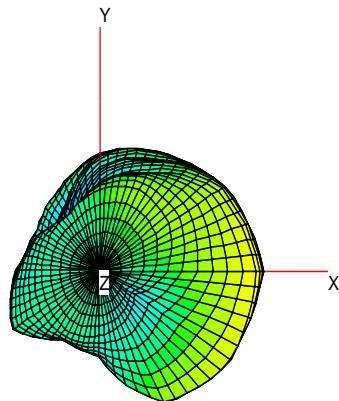

ANT4

700MHz

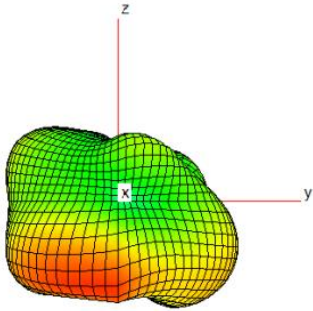

730MHz

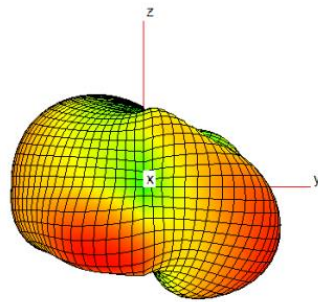

790MHz

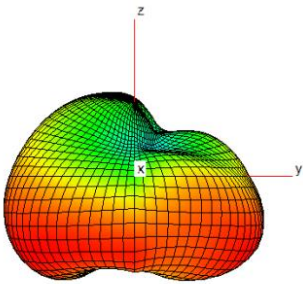

800MHz

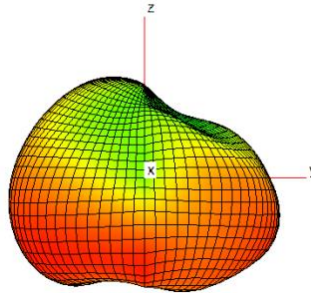

820MHz

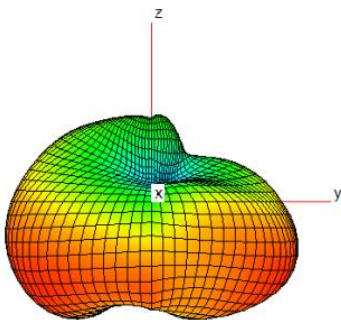

850MHz

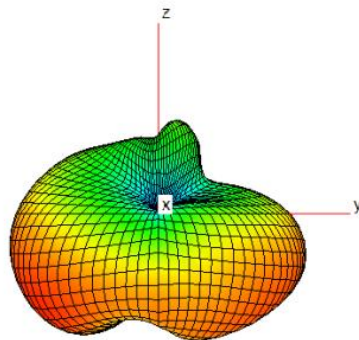

890MHz

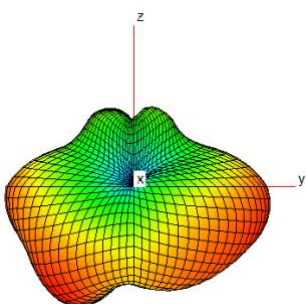

930MHz

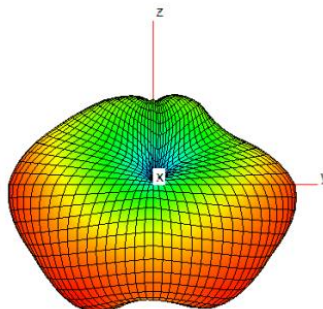

960MHz

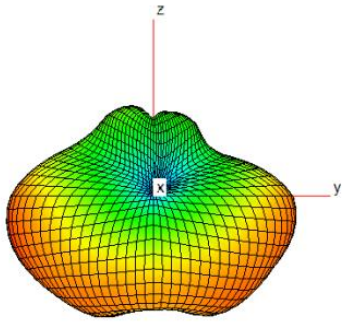

1710MHz

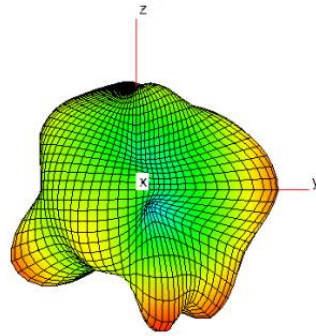

1850MHz

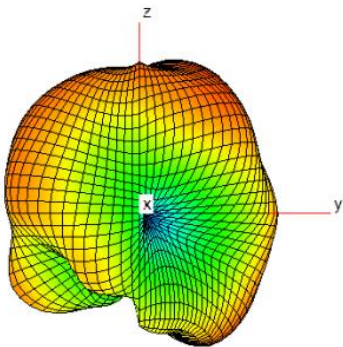

1880MHz

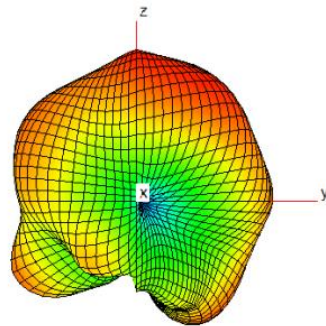

1920MHz

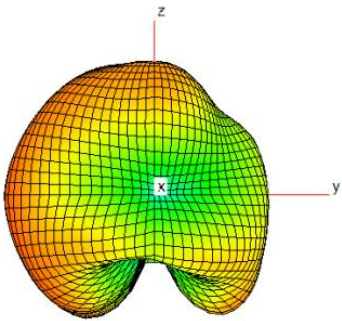

1990MHz

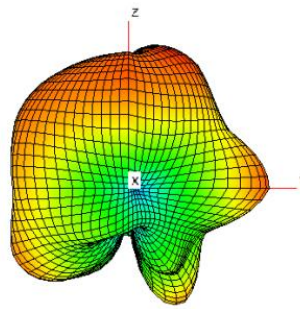

2170MHz

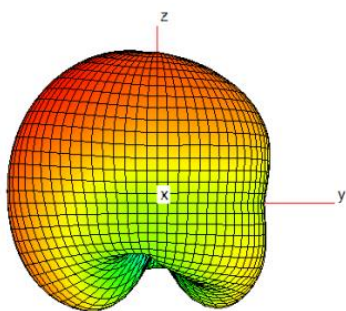

2200MHz

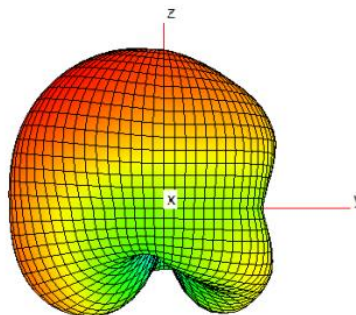

2300MHz

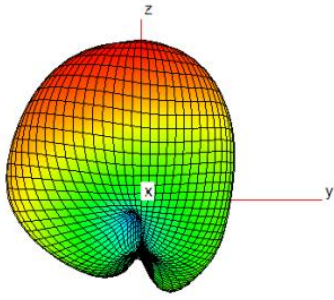

2400MHz

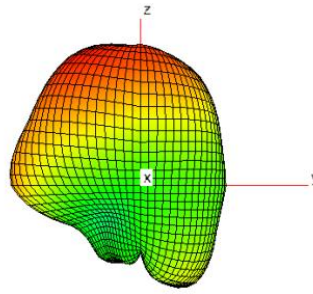

2500MHz

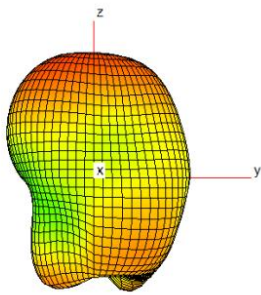

2700MHz

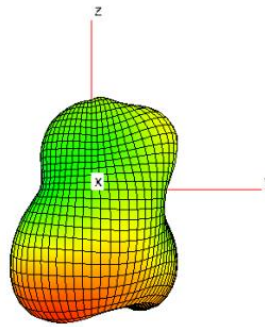

ANT5

3300MHz

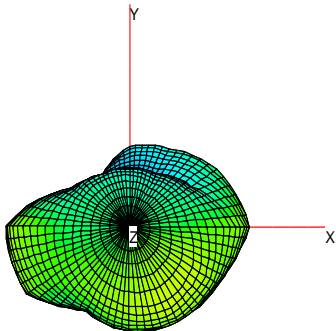

4200MHz

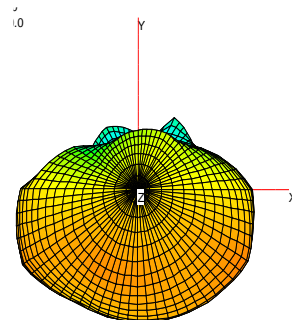

ANT6

1575MHz

2400MHz

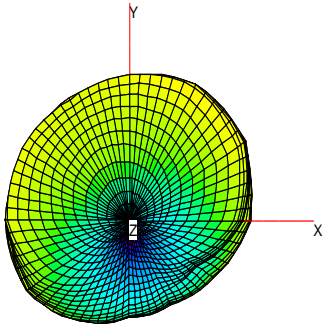

2500MHz

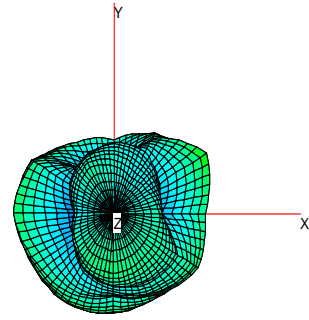

5150MHz

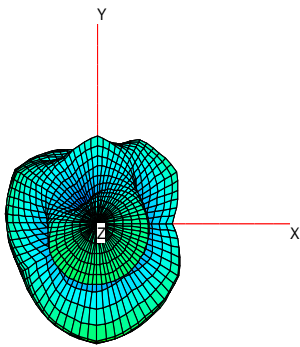

5500MHz

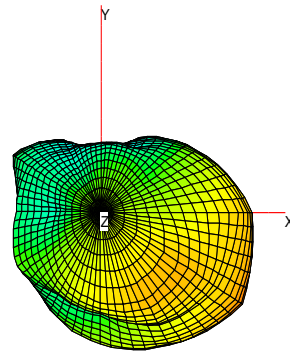

5850MHz

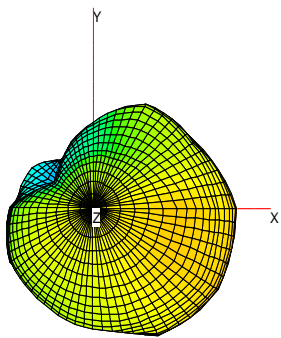

ANT7

1805MHz

= 0.0

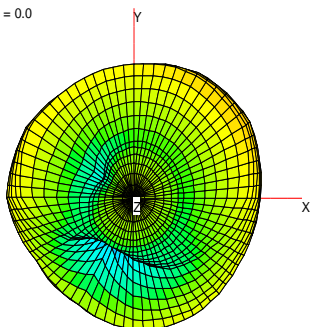

i = 0.0
)

1880MHz

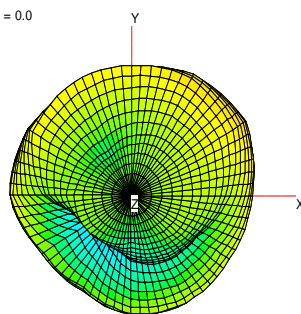

1930MHz

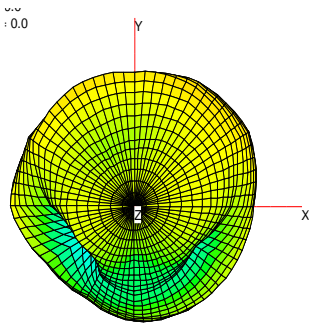

1990MHz

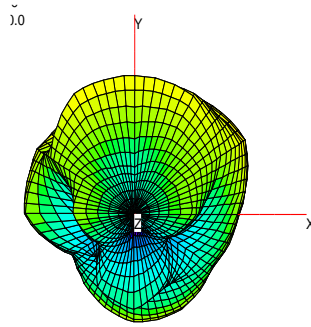

2110MHz

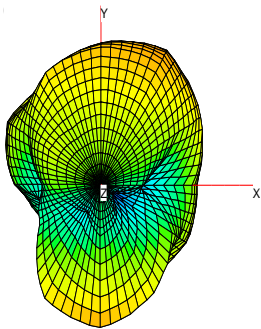

2200MHz

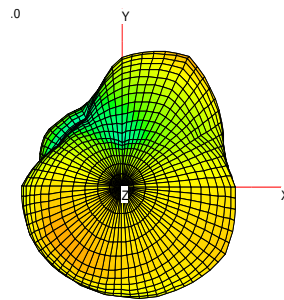

2500MHz

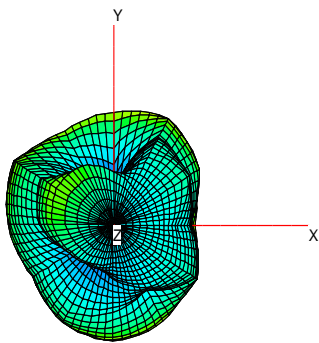

2580MHz

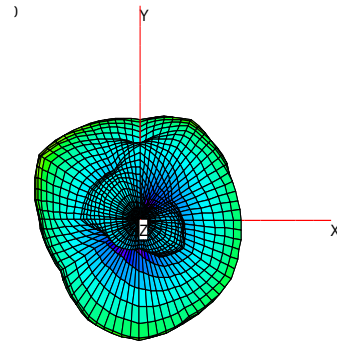

2690MHz

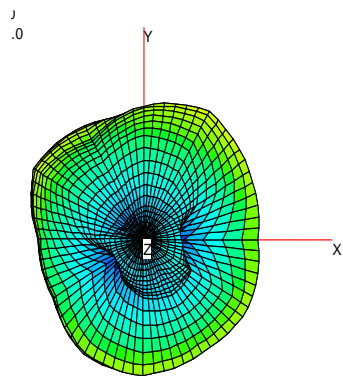

3300MHz

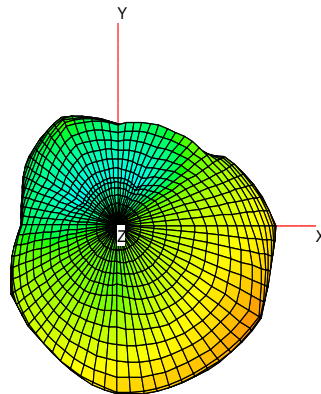

3750MHz

4200MHz

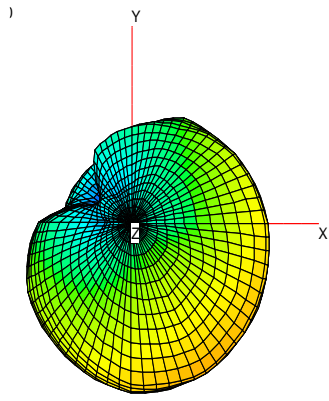

ANT8

740MHz

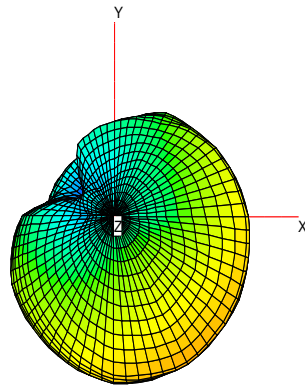

820MHz

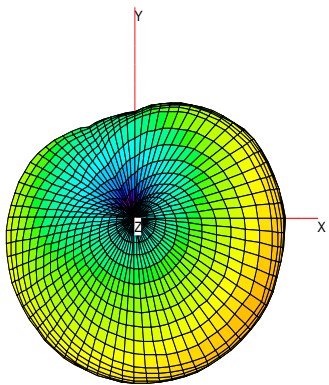

ANT9

3300MHz

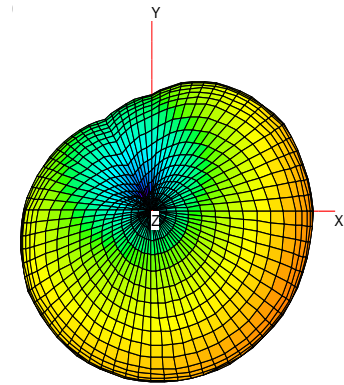

3500MHz

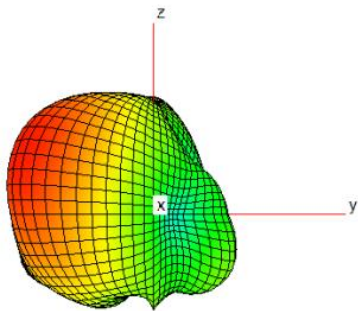

3800MHz

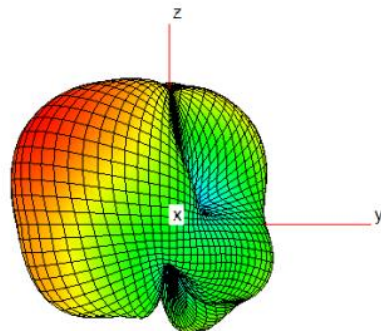

4200MHz

