



FCC PART 15C TEST REPORT No.I19Z70333-IOT14

for

Samsung Electronics. Co., Ltd.

Mobile phone

Model name: SM-A015A,SM-A015AZ

FCC ID: ZCASMA015A

With

Hardware Version: REV3.0

Software Version: A015A.001(A015AUCU0ATAC),

A015AZ.001(A015AZUCE0ATA1)

Issued Date: 2020-02-16

Note:

The test results in this test report relate only to the devices specified in this report. This report shall not be reproduced except in full without the written approval of CTTL.

The report must not be used by the client to claim product certification, approval, or endorsement by NVLAP, NIST, or any agency of the U.S.Government.

Test Laboratory:

CTTL-Telecommunication Technology Labs, CAICT

No. 52, Huayuan North Road, Haidian District, Beijing, P. R. China 100191.

Tel:+86(0)10-62304633-2512, Fax:+86(0)10-62304633-2504

Email: cttl_terminals@caict.ac.cn, website: www.caict.ac.cn



REPORT HISTORY

Report Number	Revision	Description	Issue Date
I19Z70333-IOT14	Rev.0	1st edition	2020-02-16

CONTENTS

CONTENTS	3
1. TEST LABORATORY	5
1.1. INTRODUCTION & ACCREDITATION	5
1.2. TESTING LOCATION	5
1.3. TESTING ENVIRONMENT	5
1.1. PROJECT DATE	5
1.2. SIGNATURE	5
2. CLIENT INFORMATION	6
2.1. APPLICANT INFORMATION	6
2.2. MANUFACTURER INFORMATION	6
3. EQUIPMENT UNDER TEST (EUT) AND ANCILLARY EQUIPMENT(AE)	7
3.1. ABOUT EUT	7
3.2. INTERNAL IDENTIFICATION OF EUT USED DURING THE TEST	7
3.3. INTERNAL IDENTIFICATION OF AE USED DURING THE TEST	7
3.4. GENERAL DESCRIPTION	8
4. REFERENCE DOCUMENTS	8
4.1. DOCUMENTS SUPPLIED BY APPLICANT	8
4.2. REFERENCE DOCUMENTS FOR TESTING	8
5. LABORATORY ENVIRONMENT	8
6. SUMMARY OF TEST RESULTS	9
6.1. SUMMARY OF TEST RESULTS	9
6.2. STATEMENTS	9
6.3. TEST CONDITIONS	9
7. TEST EQUIPMENTS UTILIZED	10
8. MEASUREMENT UNCERTAINTY	11
8.1. TRANSMITTER OUTPUT POWER	11
8.2. PEAK POWER SPECTRAL DENSITY	11
8.3. OCCUPIED 6DB BANDWIDTH	11
8.4. BAND EDGES COMPLIANCE	11
8.5. SPURIOUS EMISSIONS	11
8.6. AC POWER-LINE CONDUCTED EMISSION	12
ANNEX A: MEASUREMENT RESULTS	12
A.1. MEASUREMENT METHOD	12
A.2. MAXIMUM AVERAGE OUTPUT POWER-CONDUCTED	13
A.3. PEAK POWER SPECTRAL DENSITY	15
A.4. OCCUPIED 6DB BANDWIDTH	16

A.5. TRANSMITTER SPURIOUS EMISSION	24
A.5.1 TRANSMITTER SPURIOUS EMISSION - CONDUCTED	24
A.5.2 TRANSMITTER SPURIOUS EMISSION - RADIATED.....	55
A.6. BAND EDGES COMPLIANCE	63
A6.1 BAND EDGES - CONDUCTED.....	63
A6.2 BAND EDGES - RADIATED.....	70
FIG. 83 BAND EDGES (802.11A, 5745MHZ)	71
FIG. 84 BAND EDGES (802.11A, 5825MHZ)	71
FIG. 85 BAND EDGES (802.11N-HT20, 5745MHZ).....	72
FIG. 86 BAND EDGES (802.11N-HT20, 5825MHZ).....	72
FIG. 87 BAND EDGES (802.11AC-HT20, 5745MHZ).....	73
FIG. 88 BAND EDGES (802.11AC-HT20, 5825MHZ).....	73
FIG. 89 BAND EDGES (802.11N-HT40, 5755MHZ).....	74
FIG. 90 BAND EDGES (802.11N-HT40, 5795MHZ).....	74
FIG. 91 BAND EDGES (802.11AC-HT40, 5755MHZ).....	75
FIG. 92 BAND EDGES (802.11AC-HT40, 5795MHZ).....	75
FIG. 93 BAND EDGES (802.11AC-HT80, 5775MHZ).....	76
FIG. 94 BAND EDGES (802.11AC-HT80, 5775MHZ).....	76
A.7. AC POWERLINE CONDUCTED EMISSION.....	77
FIG. 95 AC POWERLINE CONDUCTED EMISSION-802.11A	78
FIG. 96 AC POWERLINE CONDUCTED EMISSION-IDLE.....	79
ANNEX B: ACCREDITATION CERTIFICATE.....	80

1. TEST LABORATORY

1.1. Introduction & Accreditation

Telecommunication Technology Labs, CAICT is an ISO/IEC 17025:2005 accredited test laboratory under NATIONAL VOLUNTARY LABORATORY ACCREDITATION PROGRAM (NVLAP) with lab code 600118-0, and is also an FCC accredited test laboratory (CN5017), and ISED accredited test laboratory (CN0066). The detail accreditation scope can be found on NVLAP website.

1.2. Testing Location

Conducted testing Location: CTTL(huayuan North Road)

Address: No. 52, Huayuan North Road, Haidian District, Beijing,
P. R. China100191

Radiated testing Location: CTTL(huayuan North Road)

Address: No. 52, Huayuan North Road, Haidian District, Beijing,
P. R. China100191

Radiated testing Location: CTTL(BDA)

Address: No.18A, Kangding Street, Beijing Economic-Technology
Development Area, Beijing, P. R. China 100176

1.3. Testing Environment

Normal Temperature: -10-55℃

Relative Humidity: 25-75%

1.1. Project date

Testing Start Date: 2019-12-02

Testing End Date: 2020-02-16

1.2. Signature



Xie Fangfang

(Prepared this test report)

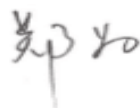

Zheng Wei

(Reviewed this test report)



Hu Xiaoyu

(Approved this test report)

2. CLIENT INFORMATION

2.1. Applicant Information

Company Name: Samsung Electronics. Co., Ltd.
R5, A Tower 22 Floor A-1,(Maetan dong)
Address: 129,Samsung-ro,Yeongtong-gu, Suwon-Si, Gyeonggi-do 16677,
Korea
City: /
Postal Code: /
Country: Korea
Telephone: +82-10-4376-0326
Fax: /

2.2. Manufacturer Information

Company Name: Samsung Electronics. Co., Ltd.
R5, A Tower 22 Floor A-1,(Maetan dong)
Address: 129,Samsung-ro,Yeongtong-gu, Suwon-Si, Gyeonggi-do 16677,
Korea
City: /
Postal Code: /
Country: Korea
Telephone: +82-10-4376-0326
Fax: /

3. EQUIPMENT UNDER TEST (EUT) AND ANCILLARY

EQUIPMENT(AE)

3.1. About EUT

Description	Mobile phone
Model name	SM-A015A,SM-A015AZ
FCC ID	ZCASMA015A
WLAN Frequency Range	ISM Band: 5725MHz~5850MHz
Type of modulation	OFDM
Voltage	3.85V

3.2. Internal Identification of EUT used during the test

EUT ID*	SN or IMEI	HW Version	SW Version
EUT3	351766110007292	REV3.0	A015A.001(A015AUCU0ATAC), A015AZ.001(A015AZUCE0ATA1)
EUT2	351766110010882	REV3.0	A015A.001(A015AUCU0ATAC), A015AZ.001(A015AZUCE0ATA1)

*EUT ID: is used to identify the test sample in the lab internally.

3.3. Internal Identification of AE used during the test

AE ID*	Description	SN
AE1	Battery	/
AE3	Charger	/
AE6	USB Cable	/
AE1		
Model	QL1695	
Manufacturer	Ningde Amperex Technology Limited	
Capacitance	/	
Nominal voltage	3.85 V	
AE3		
Model	EP-TA50JWE	
Manufacturer	DongYang E&P Inc.	
Length of cable	/	
AE6		
Model	ECB-DU68WE	
Manufacturer	SHENGHUA	
Length of cable	/	

*AE ID: is used to identify the test sample in the lab internally.

3.4. General Description

Equipment Under Test (EUT) is a model of Mobile phone with integrated antenna. It consists of normal options: Battery and Charger.

Manual and specifications of the EUT were provided to fulfil the test.

Samples undergoing test were selected by the Client.

4. REFERENCE DOCUMENTS

4.1. Documents supplied by applicant

EUT feature information is supplied by the applicant or manufacturer, which is the basis of testing.

4.2. Reference Documents for testing

The following documents listed in this section are referred for testing.

FCC Part15	FCC CFR 47, Part 15, Subpart C and E: 15.205 Restricted bands of operation; 15.209 Radiated emission limits, general requirements; 15.407 General technical requirements	2018
ANSI C63.10	Methods of Measurement of Radio-Noise Emissions from Low-Voltage Electrical and Electronic Equipment in the Range of 9 kHz to 40 GHz	2013
UNII: KDB 789033 D02	General U-NII Test Procedures New Rules v02r01	2017-12
KDB 558074 D01	Federal Communications Commission Office of Engineering and Technology Laboratory Division GUIDANCE FOR COMPLIANCE MEASUREMENTS ON DIGITAL TRANSMISSION SYSTEM, FREQUENCY HOPPING SPREAD SPECTRUM SYSTEM, AND HYBRID SYSTEM DEVICES OPERATING UNDER SECTION 15.247 OF THE FCC RULES	2019

5. LABORATORY ENVIRONMENT

Conducted RF performance testing is performed in shielding room.

EMC performance testing is performed in Semi-anechoic chamber.

6. SUMMARY OF TEST RESULTS

6.1. Summary of Test Results

SUMMARY OF MEASUREMENT RESULTS	Sub-clause of Part15C	Sub-clause of IC	Verdict
Maximum Peak Output Power	15.407 (a)	/	P
Peak Power Spectral Density	15.407 (a)	/	P
Occupied 6dB Bandwidth	15.407 (e)	/	P
Band Edges Compliance - Conducted& Radiated	15.407 (b)	/	P
Transmitter Spurious Emission - Conducted	15.407	/	P
Transmitter Spurious Emission - Radiated	15.407, 15.205, 15.209	/	P
AC Powerline Conducted Emission	15.107, 15.207	/	P

Please refer to **ANNEX A** for detail.

Terms used in Verdict column

P	Pass, The EUT complies with the essential requirements in the standard.
NM	Not measured, The test was not measured by CTTL
NA	Not Applicable, The test was not applicable
F	Fail, The EUT does not comply with the essential requirements in the standard

6.2. Statements

CTTL has evaluated the test cases requested by the client/matrix manufacturer as listed in section 6.1 of this report for the EUT specified in section 3 according to the standards or reference documents listed in section 4.1.

This report only deals with the WLAN function among the features described in section 3.

6.3. Test Conditions

For this report, all the test cases are tested under normal temperature and normal voltage, and also under norm humidity, the specific condition is shown as follows:

Temperature 26°C
 Voltage 3.85V
 Humidity 44%

7. TEST EQUIPMENTS UTILIZED

Conducted test system

No.	Equipment	Model	Serial Number	Manufacturer	Calibration Period	Calibration Due date
1	Vector Signal Analyzer	FSQ40	200089	Rohde & Schwarz	1 year	2020-05-15
2	Test Receiver	ENV216	101200	Rohde & Schwarz	1 year	2020-04-27
3	LISN	ESCI	100344	Rohde & Schwarz	1 year	2021-02-14
4	Shielding Room	S81	/	ETS-Lindgren	/	/

Radiated emission test system

No.	Equipment	Model	Serial Number	Manufacturer	Calibration Period	Calibration Due date
1	Test Receiver	ESU26	100235	R&S	1 year	2020-02-27
2	BiLog Antenna	VULB9163	1222	Schwarzbeck	1 year	2020-03-14
3	Dual-Ridge Waveguide Horn Antenna	3117	00139065	ETS-Lindgren	3 years	2020-11-10
4	Dual-Ridge Waveguide Horn Antenna	3116	2663	ETS-Lindgren	3 years	2020-06-18
5	Vector Signal Analyzer	FSV	101047	Rohde & Schwarz	1 year	2020-05-16

8. Measurement Uncertainty

8.1. Transmitter Output Power

Measurement Uncertainty: 0.387dB,k=1.96

8.2. Peak Power Spectral Density

Measurement Uncertainty: 0.705dB,k=1.96

8.3. Occupied 6dB Bandwidth

Measurement Uncertainty: 60.80Hz,k=1.96

8.4. Band Edges Compliance

Measurement Uncertainty : 0.62dB,k=1.96

8.5. Spurious Emissions

Conducted (k=1.96)

Frequency Range	Uncertainty(dB)
$30\text{MHz} \leq f \leq 2\text{GHz}$	1.22
$2\text{GHz} \leq f \leq 3.6\text{GHz}$	1.22
$3.6\text{GHz} \leq f \leq 8\text{GHz}$	1.22
$8\text{GHz} \leq f \leq 12.75\text{GHz}$	1.51
$12.75\text{GHz} \leq f \leq 26\text{GHz}$	1.51
$26\text{GHz} \leq f \leq 40\text{GHz}$	1.59

Radiated (k=2)

Frequency Range	Uncertainty(dB)
9kHz-30MHz	/
$30\text{MHz} \leq f \leq 1\text{GHz}$	5.40

$1\text{GHz} \leq f \leq 18\text{GHz}$	4.32
$18\text{GHz} \leq f \leq 40\text{GHz}$	5.26

8.6. AC Power-line Conducted Emission

Measurement Uncertainty : 3.08dB,k=2

ANNEX A: MEASUREMENT RESULTS

A.1. Measurement Method

A.1.1. Conducted Measurements

- 1). Connect the EUT to the test system correctly.
- 2). Set the EUT to the required work mode.
- 3). Set the EUT to the required channel.
- 4). Set the spectrum analyzer to start measurement.
- 5). Record the values. Vector Signal Analyzer

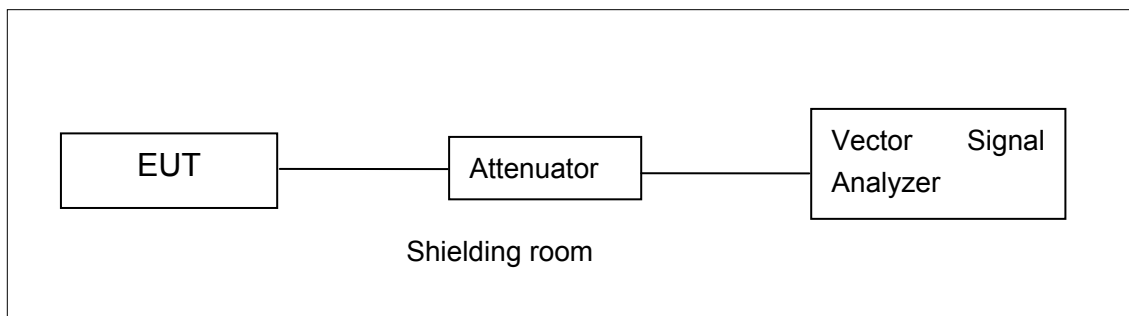

A.1.2. Radiated Emission Measurements

In the case of radiated emission, the used settings are as follows,

Sweep frequency from 30 MHz to 1GHz, RBW = 100 kHz, VBW = 300 kHz;

Sweep frequency from 1 GHz to 26GHz, RBW = 1MHz, VBW = 10Hz;

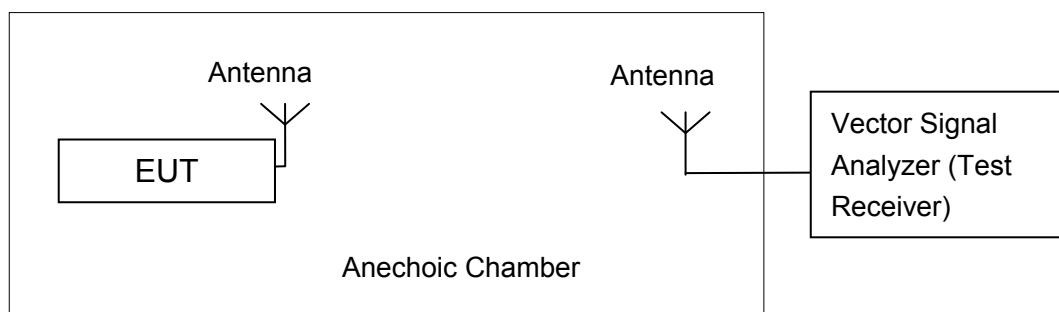

The measurement is made according to ANSI C63.10.

The radiated emission test is performed in semi-anechoic chamber. The distance from the EUT to the reference point of measurement antenna is 3m. The test is carried out on both vertical and horizontal polarization and only maximization result of both polarizations is kept. During the test,

the turntable is rotated 360° and the measurement antenna is moved from 1m to 4m to get the maximization result.

A.2. Maximum Average Output Power-Conducted

Method of Measurement: See ANSI C63.10-clause 12.3.2.2 Method SA-1

Measurement Limit and Method:

Standard	Limit (dBm)
FCC CRF Part 15.407(a)	< 30

Measurement Results:

Measurement Results:

Duty cycle:

802.11a mode	802.11n-HT20 mode	802.11ac-HT20 mode	802.11n-HT40 mode	802.11ac-HT40 mode	802.11ac-HT80 mode
6Mbps	MCS0	MCS0	MCS0	MCS0	MCS0
99.00%	99.00%	99.00%	98.00%	98.00%	96.00%

802.11a mode

Mode	Data Rate (Mbps)	Test Result (dBm)		
		5745MHz (Ch149)	5785MHz (Ch157)	5825MHz (Ch165)
802.11a	6	15.90	15.84	15.61

The data rate 6Mbps is selected as worse condition, and the following cases are performed with this condition.

802.11n-HT20 mode

Mode	Data Rate (Index)	Test Result (dBm)		
		5745MHz (Ch149)	5785MHz (Ch157)	5825MHz (Ch165)
802.11n (20MHz)	MCS0	15.92	15.90	15.66

The data rate MCS0 is selected as worse condition, and the following cases are performed with this condition.

802.11ac-HT20 mode

Mode	Data Rate	Test Result (dBm)
------	-----------	-------------------

	(Index)	5745MHz (Ch149)	5785MHz (Ch157)	5825MHz (Ch165)
802.11ac (20MHz)	MCS0	15.96	15.90	15.67

The data rate MCS0 is selected as worse condition, and the following cases are performed with this condition.

802.11n-HT40 mode

Mode	Data Rate (Index)	Test Result (dBm)	
		5755MHz (Ch151)	5795MHz (Ch159)
802.11n (40MHz)	MCS0	15.96	16.10

The data rate MCS0 is selected as worse condition, and the following cases are performed with this condition.

802.11ac-HT40 mode

Mode	Data Rate (Index)	Test Result (dBm)	
		5755MHz (Ch151)	5795MHz (Ch159)
802.11ac (40MHz)	MCS0	15.93	16.08

The data rate MCS0 is selected as worse condition, and the following cases are performed with this condition.

802.11ac-HT80 mode

Mode	Data Rate (Index)	Test Result (dBm)
		5775MHz (Ch155)
802.11ac (80MHz)	MCS0	15.99

The data rate MCS0 is selected as worse condition, and the following cases are performed with this condition.

Conclusion: PASS

A.3. Peak Power Spectral Density

Measurement Limit:

Standard	Limit
FCC 47 CFR Part 15.407(a)	< 30 dBm/500 kHz

The measurement is made according to ANSI C63.10 and KDB789033 D02

Measurement Uncertainty:

Measurement Uncertainty	0.75dB
-------------------------	--------

Measurement Results:

Mode	Channel	Power Spectral Density (dBm/500kHz)	Conclusion
802.11a	149	5.91	P
	157	6.17	P
	165	5.45	P
802.11n HT20	149	6.12	P
	157	6.83	P
	165	6.35	P
802.11ac HT20	149	5.48	P
	157	6.66	P
	165	6.57	P
802.11n HT40	151	9.68	P
	159	7.97	P
802.11ac HT40	151	3.10	P
	159	4.43	P
802.11ac HT80	155	0.15	P

Conclusion: PASS

A.4. Occupied 6dB Bandwidth

Measurement Limit:

Standard	Limit (kHz)
FCC 47 CFR Part 15.407 (e)	≥ 500

The measurement is made according to KDB789033 D02 .

Measurement Uncertainty:

Measurement Uncertainty	60.80Hz
-------------------------	---------

Measurement Result:

Mode	Channel	Occupied 6dB Bandwidth (MHz)		conclusion
		Fig.	Value	
802.11a	149	Fig.1	16.50	P
	157	Fig.2	16.35	P
	165	Fig.3	16.40	P
802.11n HT20	149	Fig.4	17.55	P
	157	Fig.5	17.60	P
	165	Fig.6	17.55	P
802.11ac HT20	149	Fig.7	17.55	P
	157	Fig.8	17.65	P
	165	Fig.9	17.60	P
802.11n HT40	151	Fig.10	31.28	P
	159	Fig.11	35.12	P
802.11ac HT40	151	Fig.12	34.32	P
	159	Fig.13	35.12	P
802.11ac HT80	155	Fig.14	75.04	P

Conclusion: PASS

Test graphs as below:

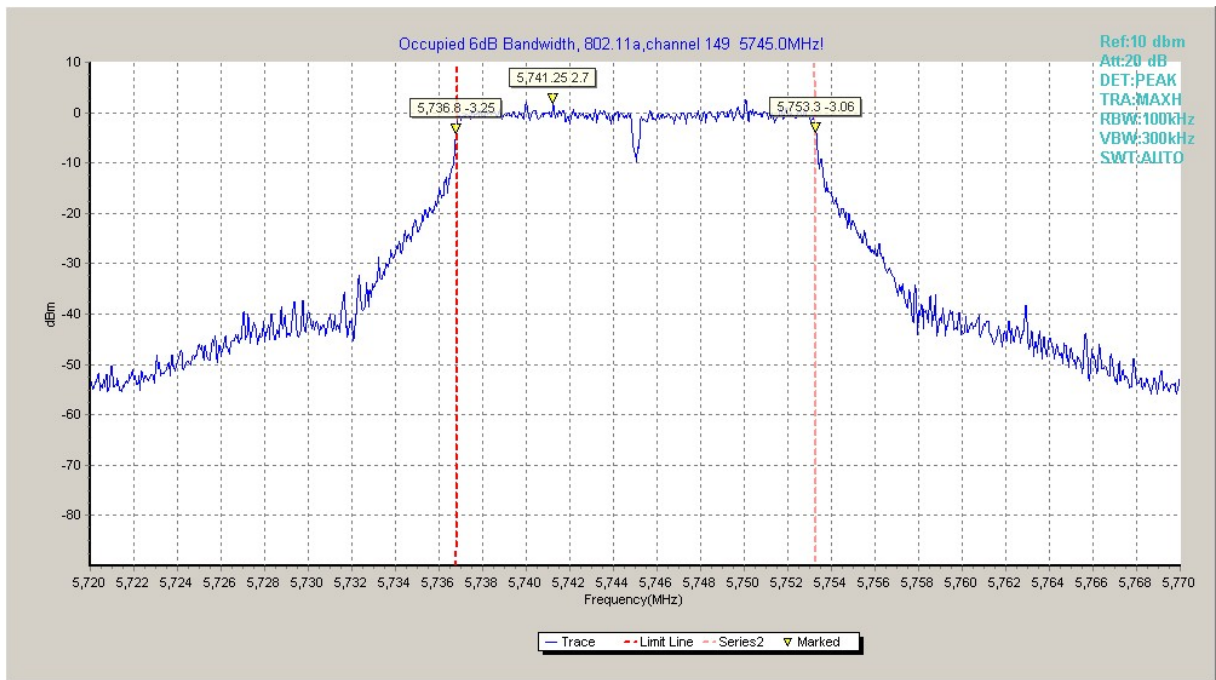

Fig. 1 Occupied 6dB Bandwidth (802.11a, Ch 149)

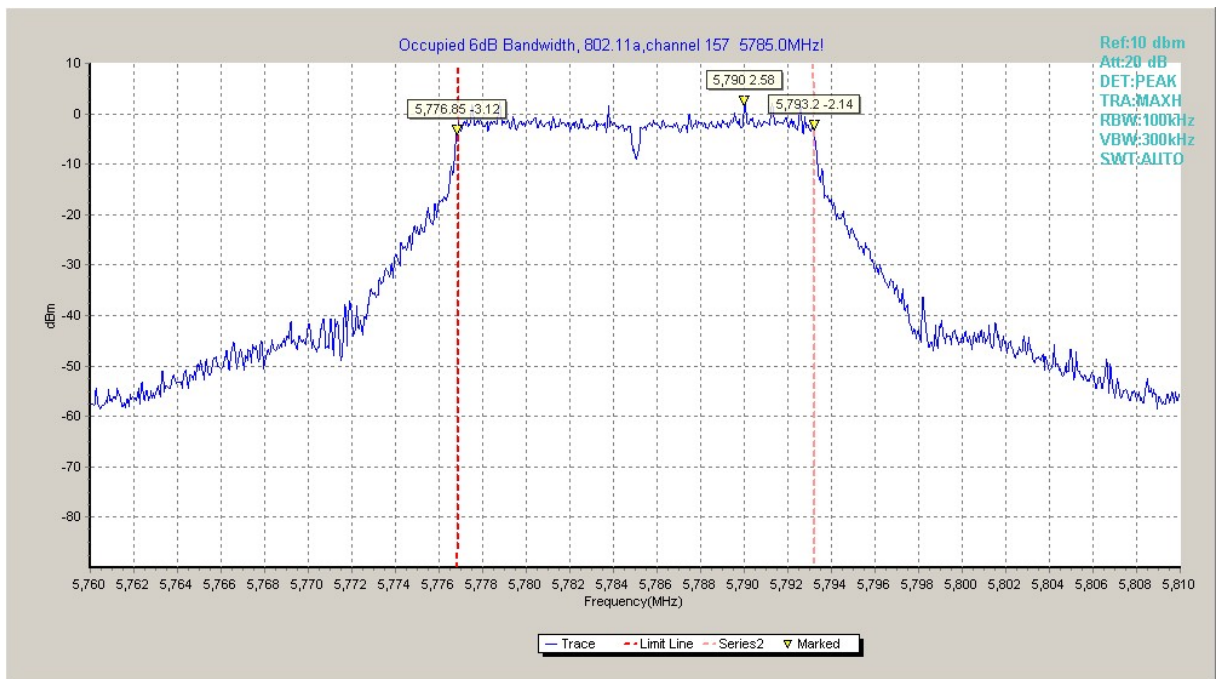

Fig. 2 Occupied 6dB Bandwidth (802.11a, Ch 157)

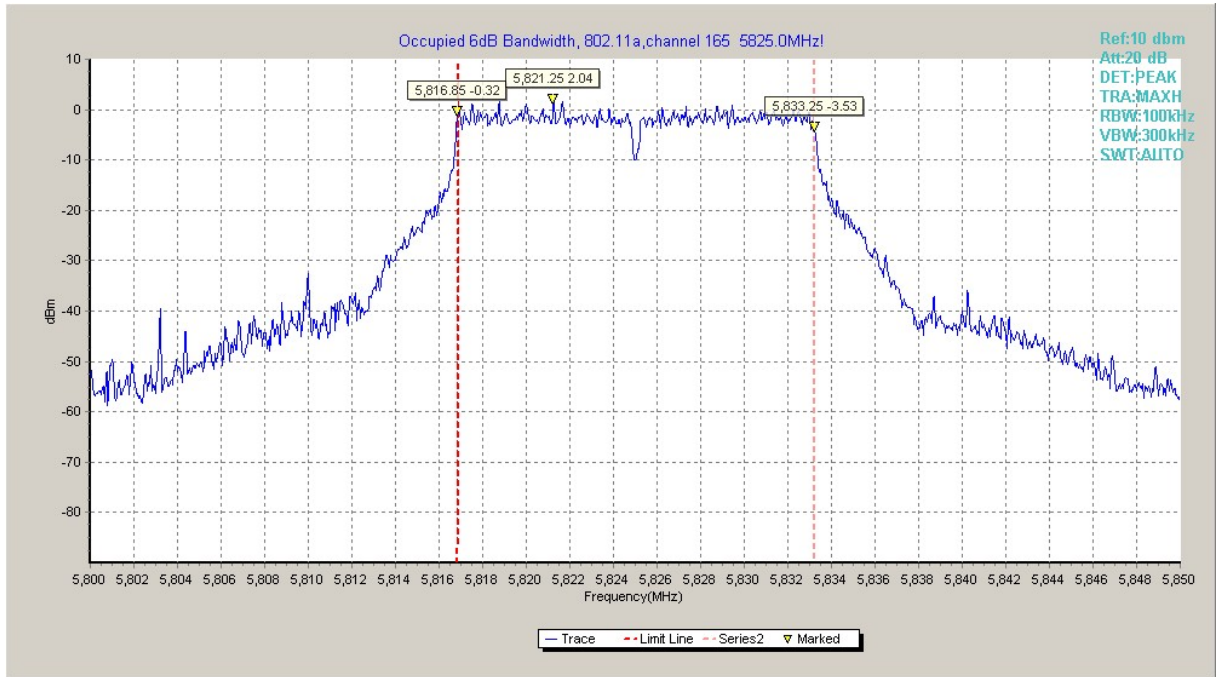

Fig. 3 Occupied 6dB Bandwidth (802.11a, Ch 165)

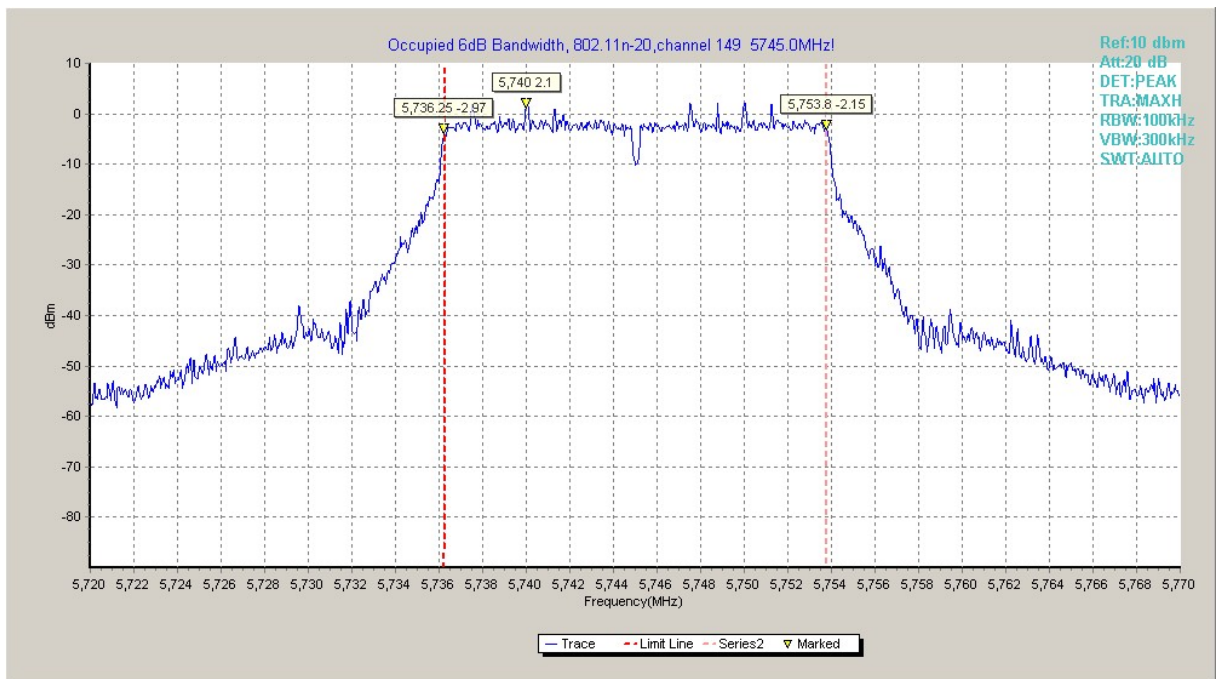

Fig. 4 Occupied 6dB Bandwidth (802.11n-HT20, Ch 149)

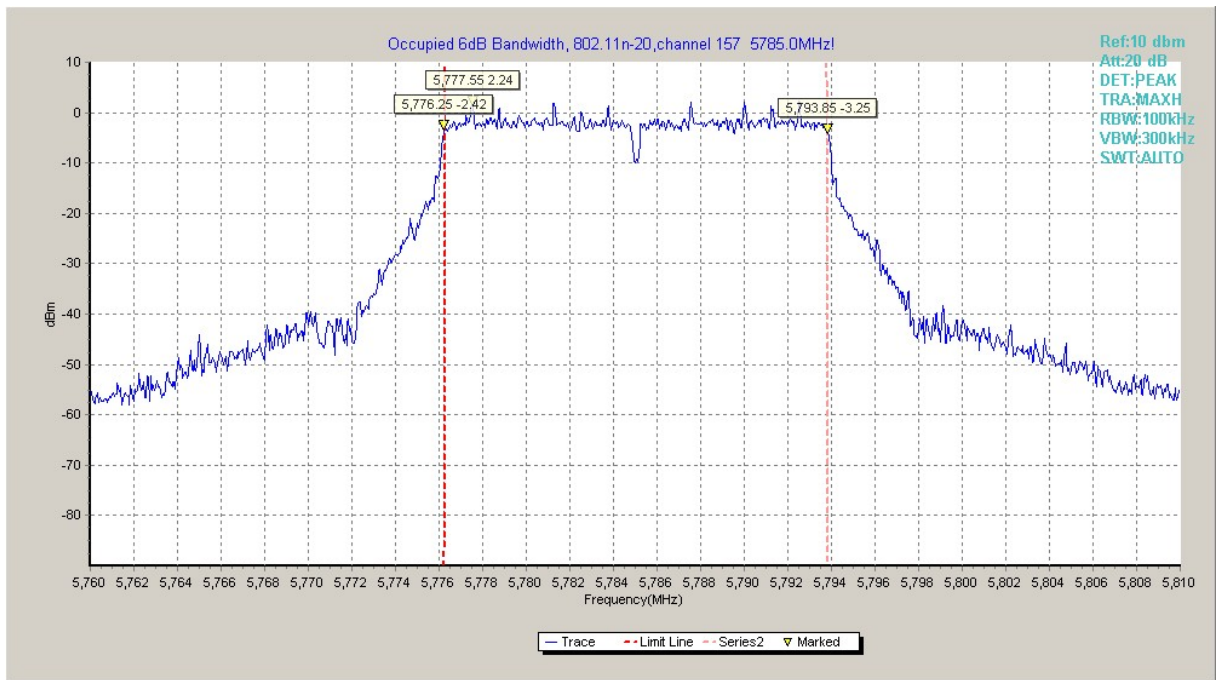

Fig. 5 Occupied 6dB Bandwidth (802.11n-HT20, Ch 157)

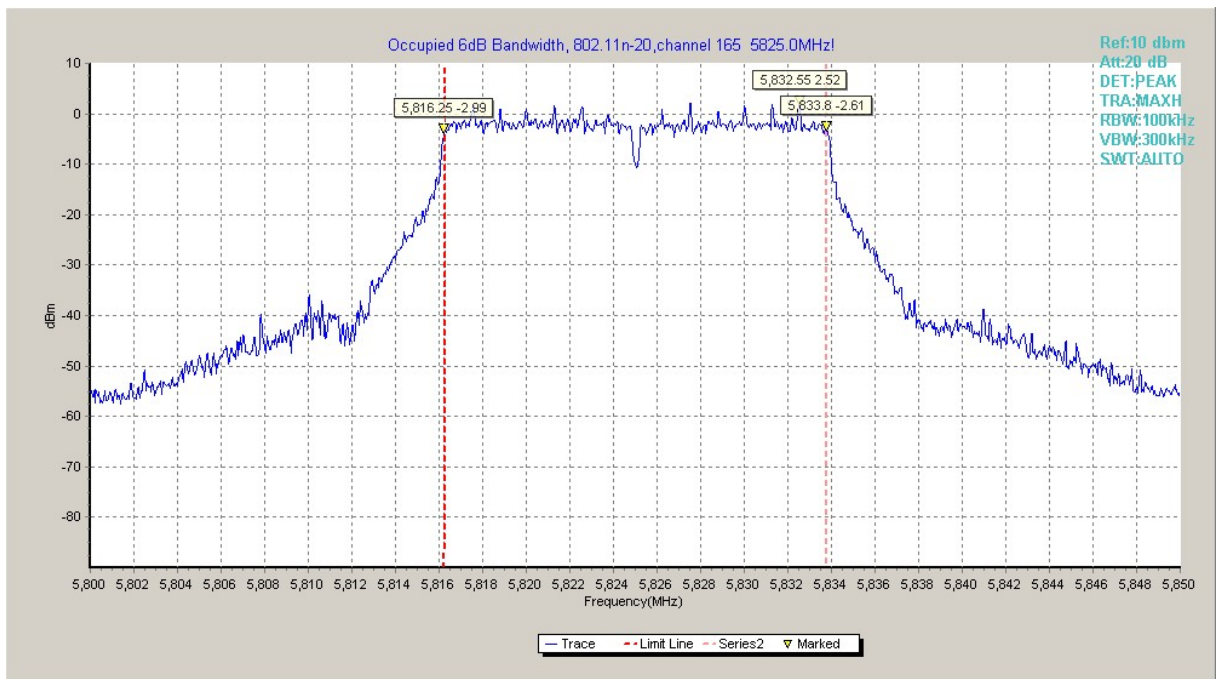

Fig. 6 Occupied 6dB Bandwidth (802.11n-HT20, Ch 165)

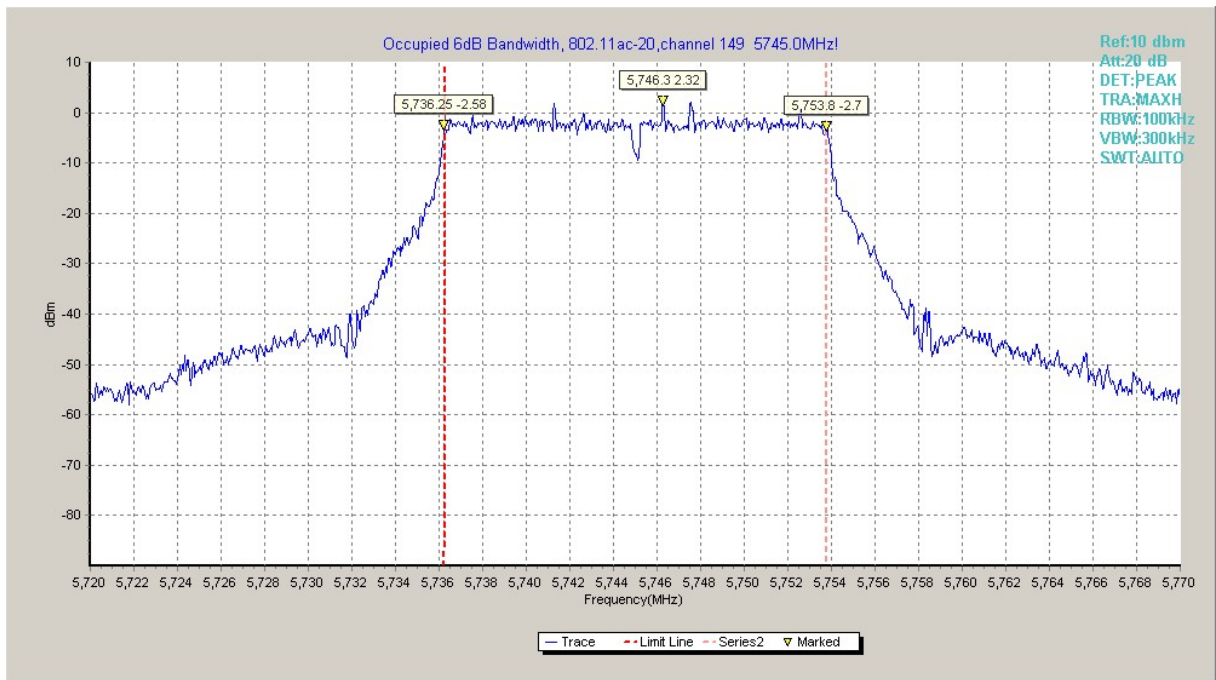

Fig. 7 Occupied 6dB Bandwidth (802.11ac-HT20, Ch 149)

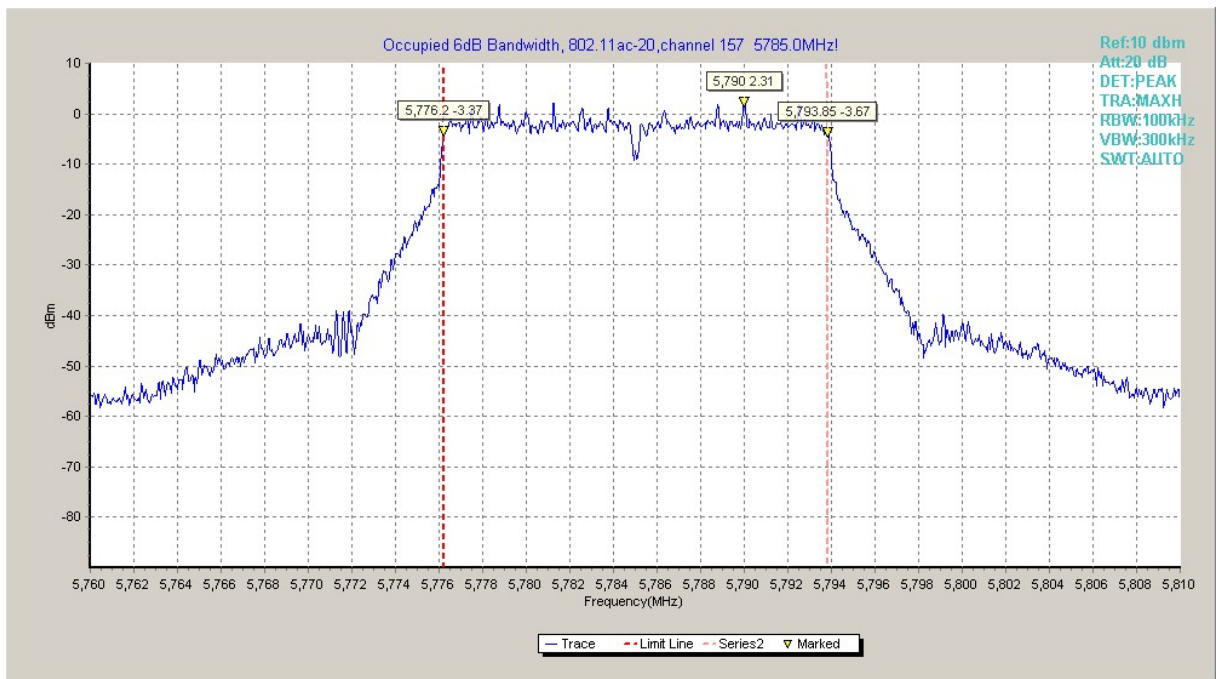

Fig. 8 Occupied 6dB Bandwidth (802.11ac-HT20, Ch 157)

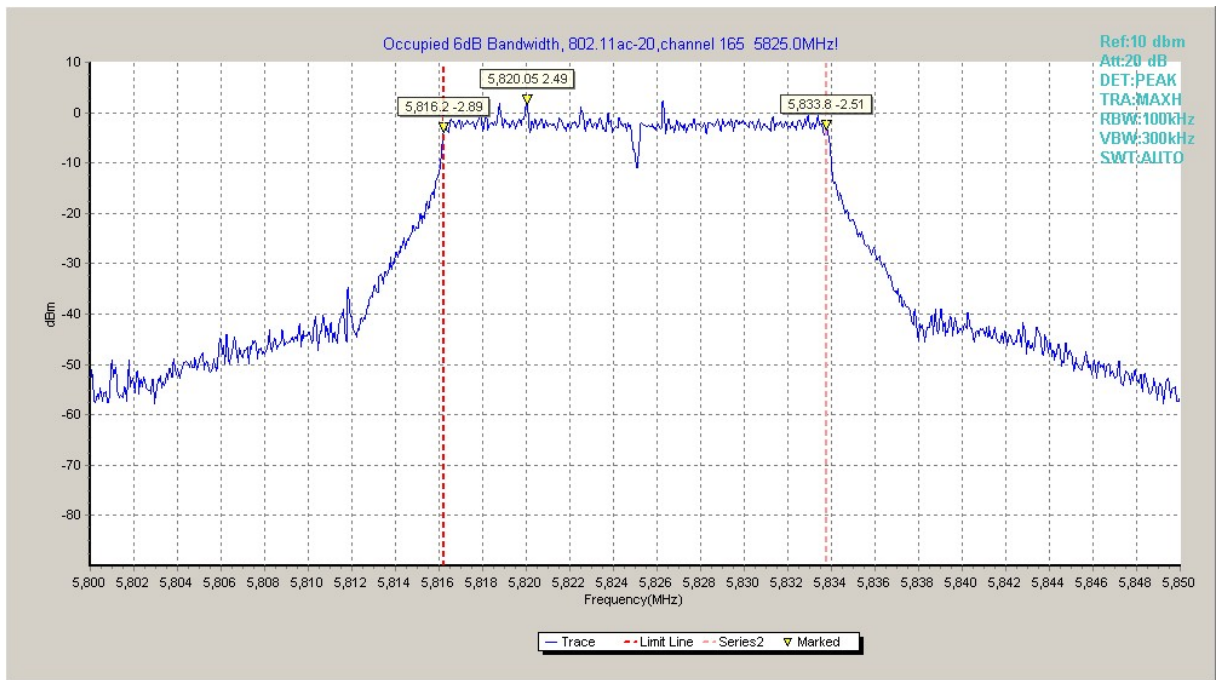

Fig. 9 Occupied 6dB Bandwidth (802.11ac-HT20, Ch 165)

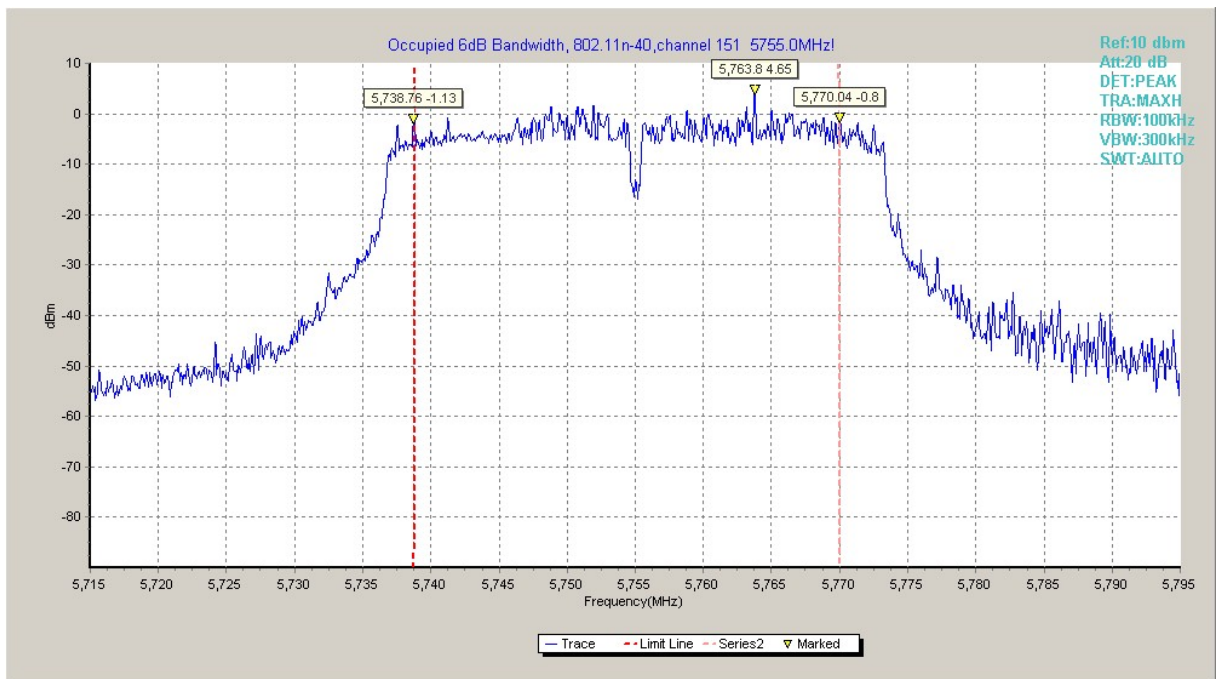

Fig. 10 Occupied 6dB Bandwidth (802.11n-HT40, Ch 151)

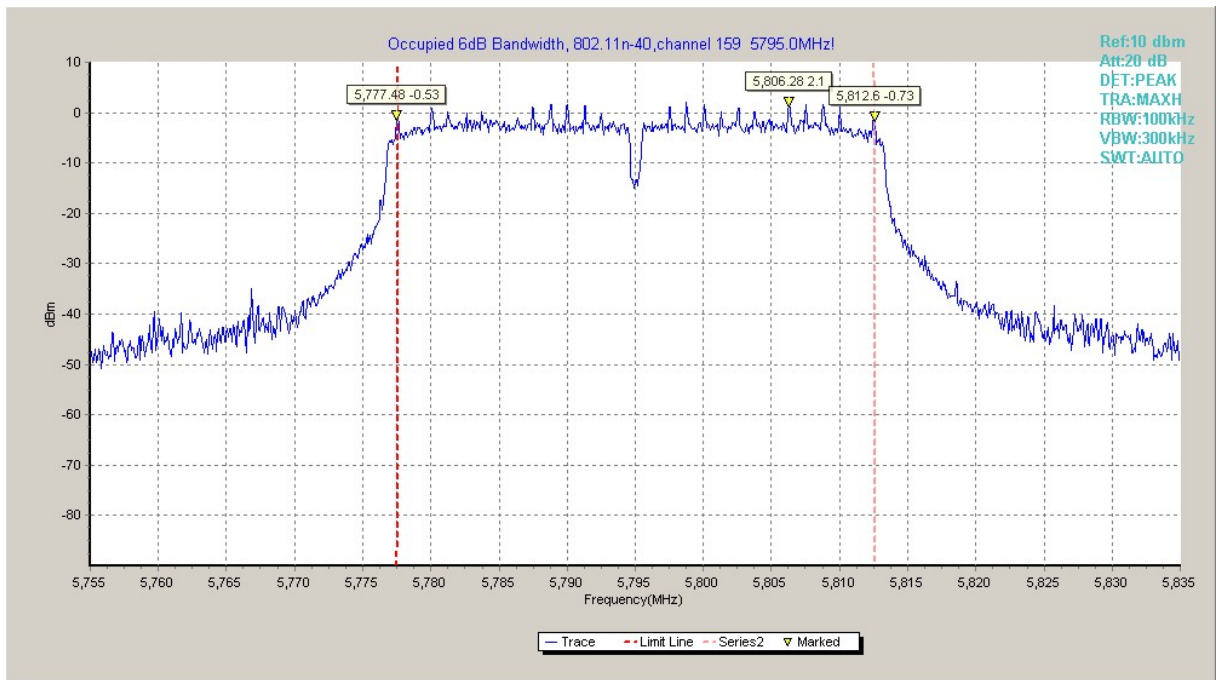

Fig. 11 Occupied 6dB Bandwidth (802.11n-HT40, Ch 159)

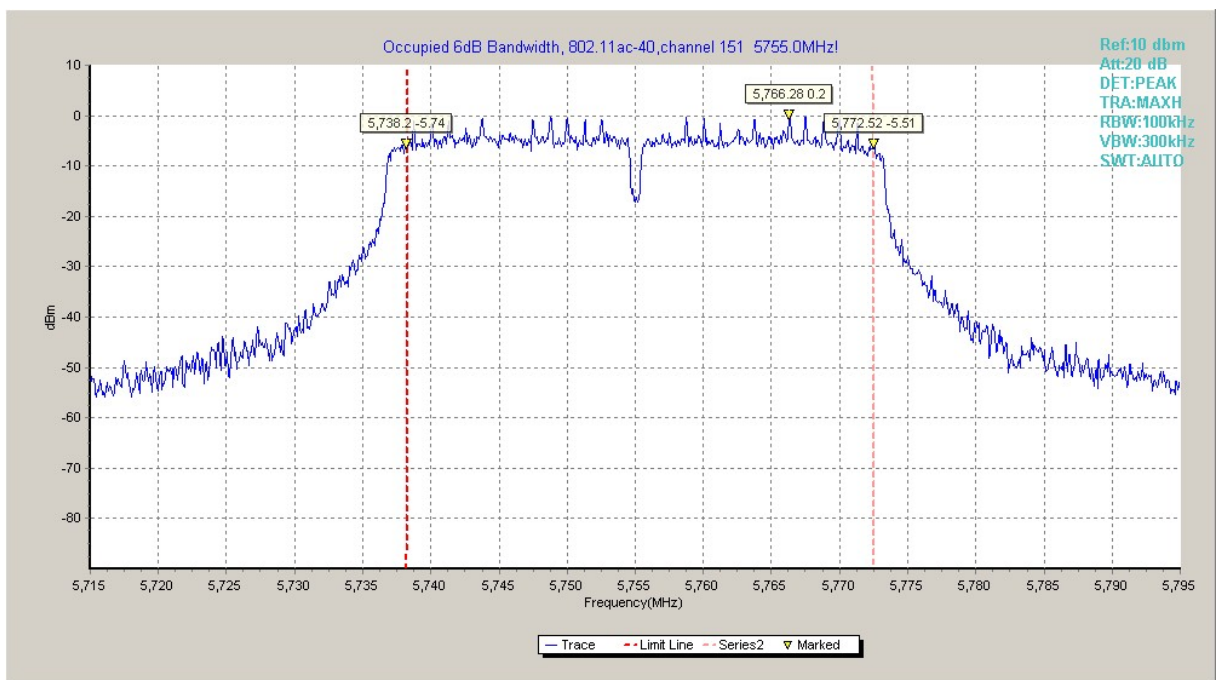

Fig. 12 Occupied 6dB Bandwidth (802.11ac-HT40, Ch 151)

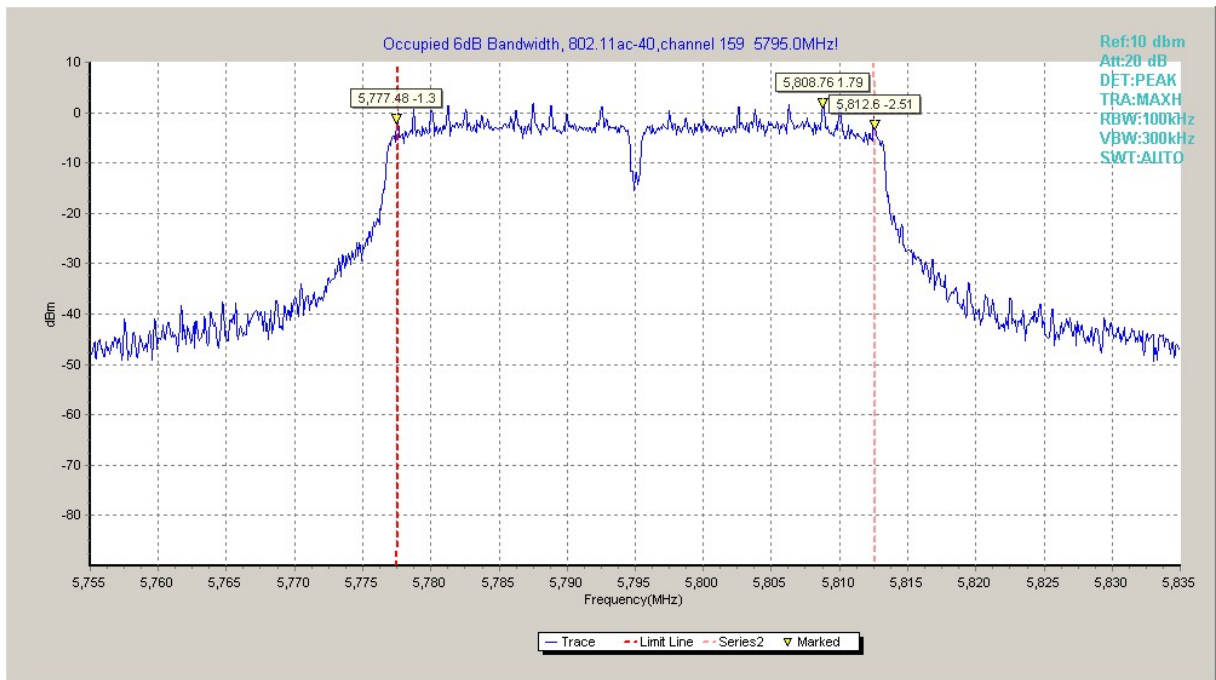

Fig. 13 Occupied 6dB Bandwidth (802.11ac-HT40, Ch 159)

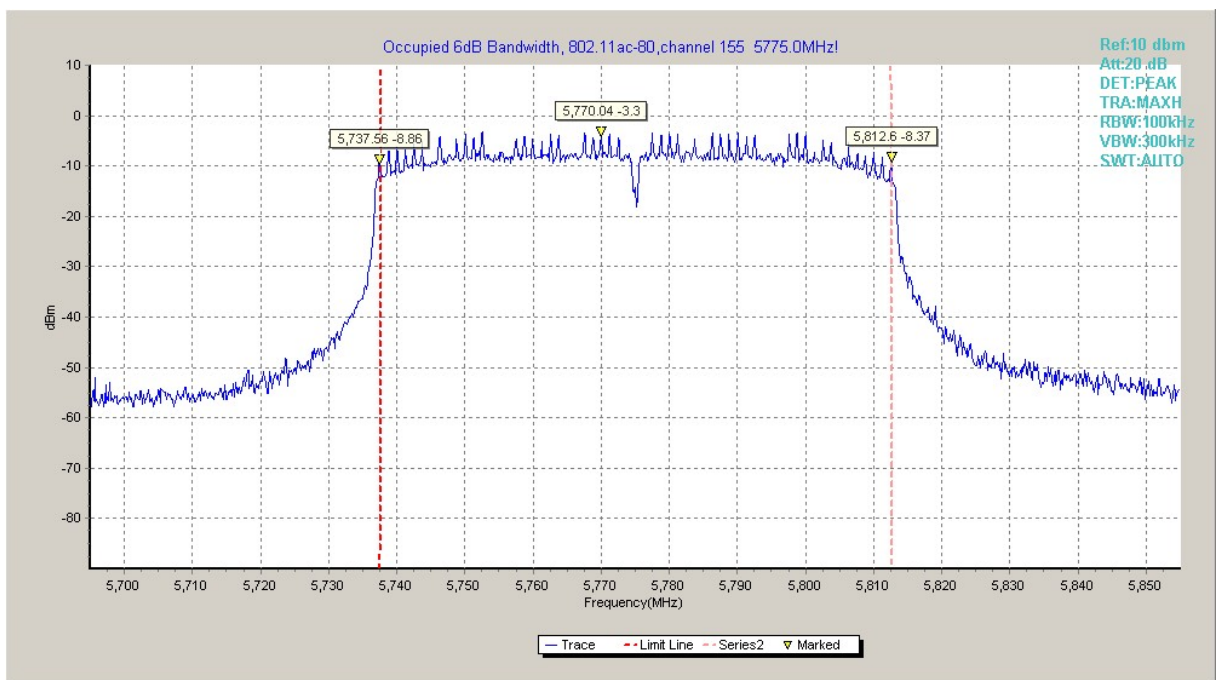

Fig. 14 Occupied 6dB Bandwidth (802.11ac-HT80, Ch 155)

A.5. Transmitter Spurious Emission

Measurement Limit:

Standard	Frequency (MHz)	Limit (dBm/MHz)
FCC 47 CFR Part 15.407	5725MHz~5850MHz	< -27

The measurement is made according to ANSI C63.10 .

In addition, radiated emissions which fall in the restricted bands, as defined in § 15.205(a), must also comply with the radiated emission limits specified in § 15.209(a) (see § 15.205(c)).

Frequency of emission (MHz)	Field strength(uV/m)	Field strength(dBuV/m)
30-88	100	40
88-216	150	43.5
216-960	200	46
Above 960	500	54

Measurement Uncertainty:

Frequency Range	Uncertainty(dB)
30MHz ≤ f ≤ 2GHz	0.63
2GHz ≤ f ≤ 3.6GHz	0.82
3.6GHz ≤ f ≤ 8GHz	1.55
8GHz ≤ f ≤ 20GHz	1.86
20GHz ≤ f ≤ 22GHz	1.90
22GHz ≤ f ≤ 26GHz	2.20

A.5.1 Transmitter Spurious Emission - Conducted

Measurement Results:

802.11a mode

MODE	Channel	Frequency Range	Test Results	Conclusion
802.11a	149	30 MHz ~ 1 GHz	Fig.15	P
		1 GHz ~ 12 GHz	Fig.16	P
		12 GHz ~ 25 GHz	Fig.17	P
		25 GHz ~ 40 GHz	Fig.18	P
	157	30 MHz ~ 1 GHz	Fig.19	P
		1 GHz ~ 12 GHz	Fig.20	P
		12 GHz ~ 25 GHz	Fig.21	P
		25 GHz ~ 40 GHz	Fig.22	P
	165	30 MHz ~ 1 GHz	Fig.23	P
		1 GHz ~ 12 GHz	Fig.24	P
		12 GHz ~ 25 GHz	Fig.25	P
		25 GHz ~ 40 GHz	Fig.26	P

802.11n-HT20 mode

MODE	Channel	Frequency Range	Test Results	Conclusion
802.11n HT20	149	30 MHz ~ 1 GHz	Fig.27	P
		1 GHz ~ 12 GHz	Fig.28	P
		12 GHz ~ 25 GHz	Fig.29	P
		25 GHz ~ 40 GHz	Fig.30	P
	157	30 MHz ~ 1 GHz	Fig.31	P
		1 GHz ~ 12 GHz	Fig.32	P
		12 GHz ~ 25 GHz	Fig.33	P
		25 GHz ~ 40 GHz	Fig.34	P
	165	30 MHz ~ 1 GHz	Fig.35	P
		1 GHz ~ 12 GHz	Fig.36	P
		12 GHz ~ 25 GHz	Fig.37	P
		25 GHz ~ 40 GHz	Fig.38	P

802.11ac-HT20 mode

MODE	Channel	Frequency Range	Test Results	Conclusion
802.11ac HT20	149	30 MHz ~ 1 GHz	Fig.39	P
		1 GHz ~ 12 GHz	Fig.40	P
		12 GHz ~ 25 GHz	Fig.41	P
		25 GHz ~ 40 GHz	Fig.42	P
	157	30 MHz ~ 1 GHz	Fig.43	P
		1 GHz ~ 12 GHz	Fig.44	P
		12 GHz ~ 25 GHz	Fig.45	P
		25 GHz ~ 40 GHz	Fig.46	P
	165	30 MHz ~ 1 GHz	Fig.47	P
		1 GHz ~ 12 GHz	Fig.48	P
		12 GHz ~ 25 GHz	Fig.49	P
		25 GHz ~ 40 GHz	Fig.50	P

802.11n-HT40 mode

MODE	Channel	Frequency Range	Test Results	Conclusion
802.11n HT40	151	30 MHz ~ 1 GHz	Fig.51	P
		1 GHz ~ 12 GHz	Fig.52	P
		12 GHz ~ 25 GHz	Fig.53	P
		25 GHz ~ 40 GHz	Fig.54	P
	159	30 MHz ~ 1 GHz	Fig.55	P
		1 GHz ~ 12 GHz	Fig.56	P
		12 GHz ~ 25 GHz	Fig.57	P
		25 GHz ~ 40 GHz	Fig.58	P

802.11ac-HT40 mode

MODE	Channel	Frequency Range	Test Results	Conclusion
802.11ac HT40	151	30 MHz ~ 1 GHz	Fig.59	P
		1 GHz ~ 12 GHz	Fig.60	P
		12 GHz ~ 25 GHz	Fig.61	P
		25 GHz ~ 40 GHz	Fig.62	P
	159	30 MHz ~ 1 GHz	Fig.63	P
		1 GHz ~ 12 GHz	Fig.64	P
		12 GHz ~ 25 GHz	Fig.65	P
		25 GHz ~ 40 GHz	Fig.66	P

802.11ac-HT80 mode

MODE	Channel	Frequency Range	Test Results	Conclusion
802.11ac HT80	155	30 MHz ~ 1 GHz	Fig.67	P
		1 GHz ~ 12 GHz	Fig.68	P
		12 GHz ~ 25 GHz	Fig.69	P
		25 GHz ~ 40 GHz	Fig.70	P

Conclusion: PASS

Test graphs as below:

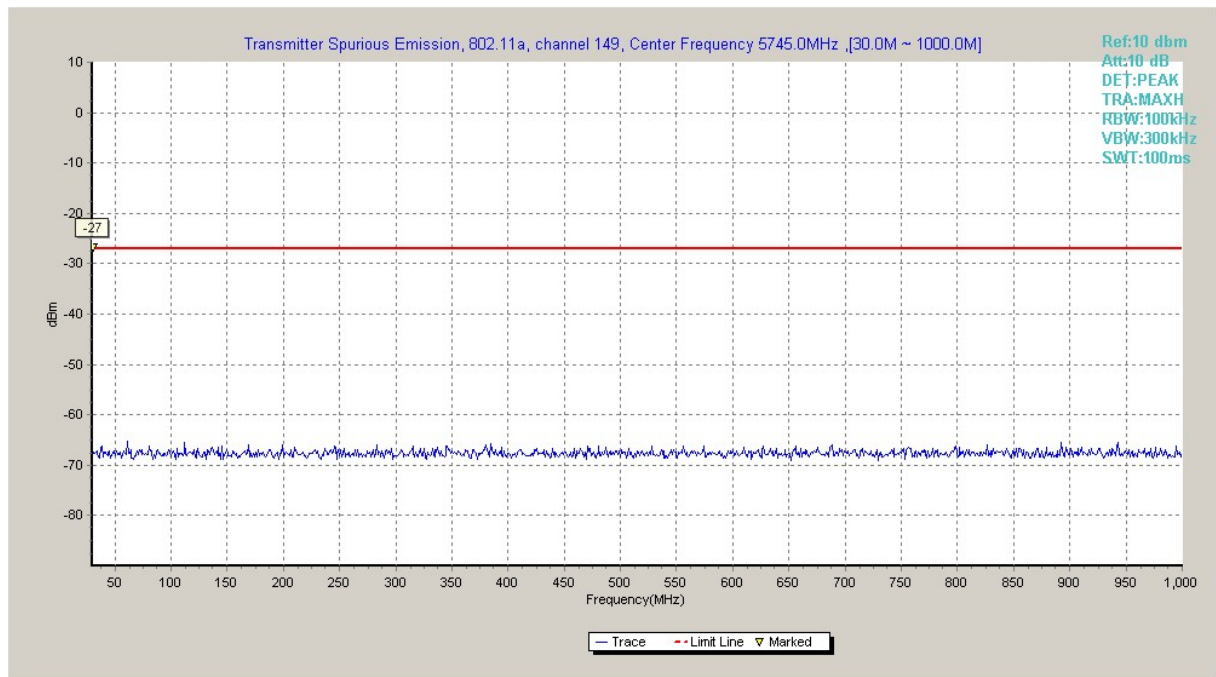

Fig. 15 Conducted Spurious Emission (802.11a, Ch149, 30 MHz-1 GHz)

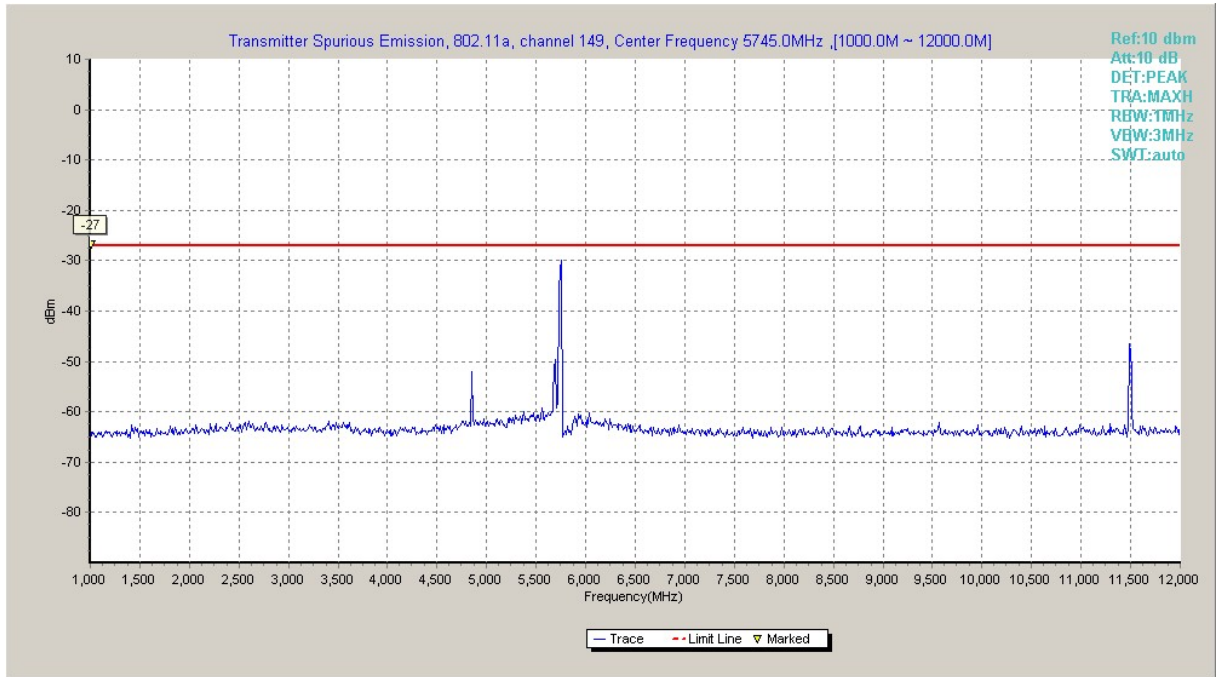

Fig. 16 Conducted Spurious Emission (802.11a, Ch149, 1 GHz -12 GHz)

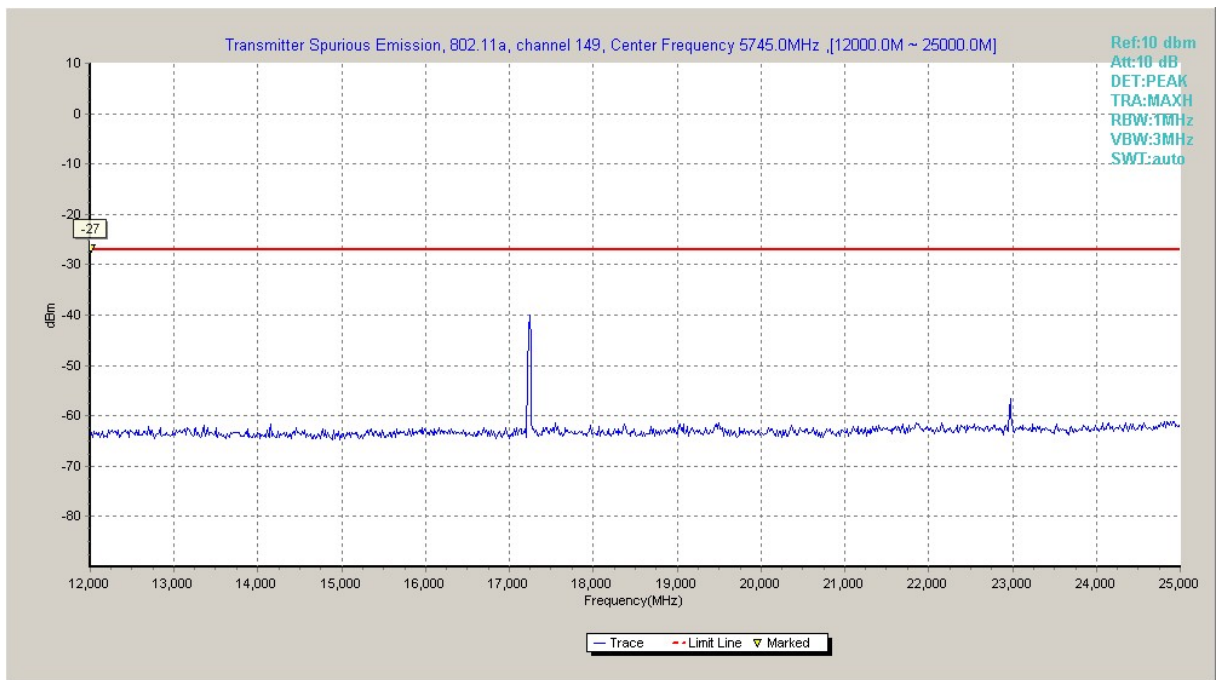

Fig. 17 Conducted Spurious Emission (802.11a, Ch149, 12 GHz-25 GHz)

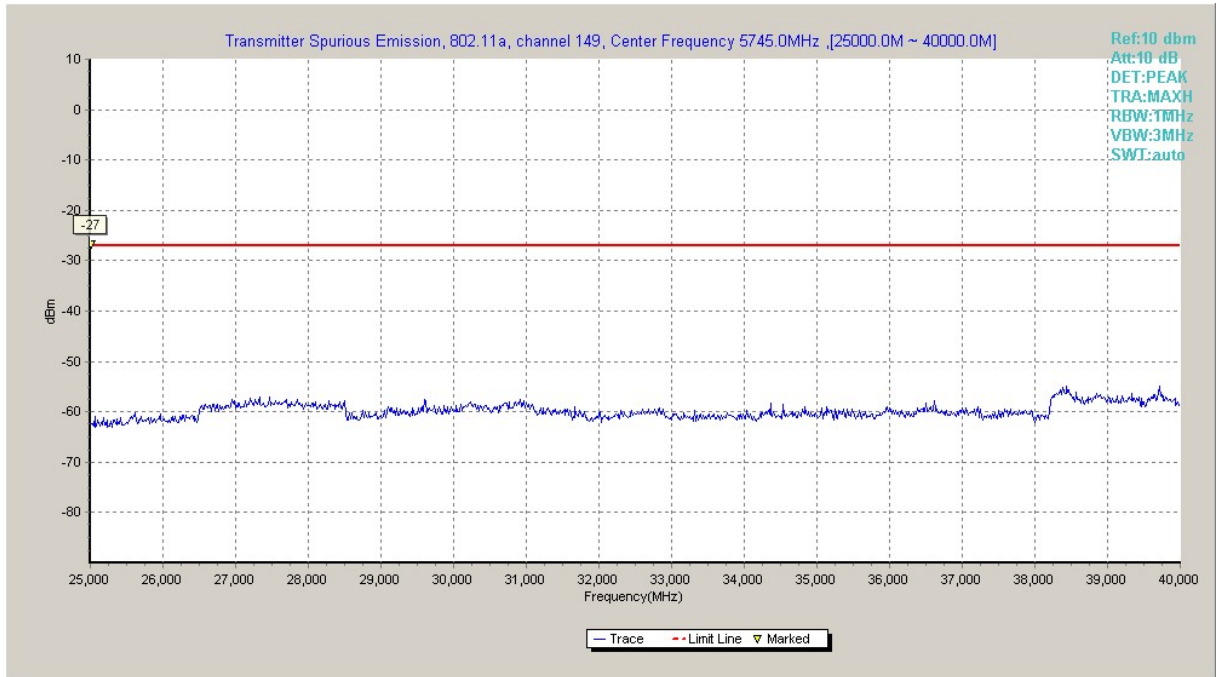

Fig. 18 Conducted Spurious Emission (802.11a, Ch149, 25 GHz-40 GHz)

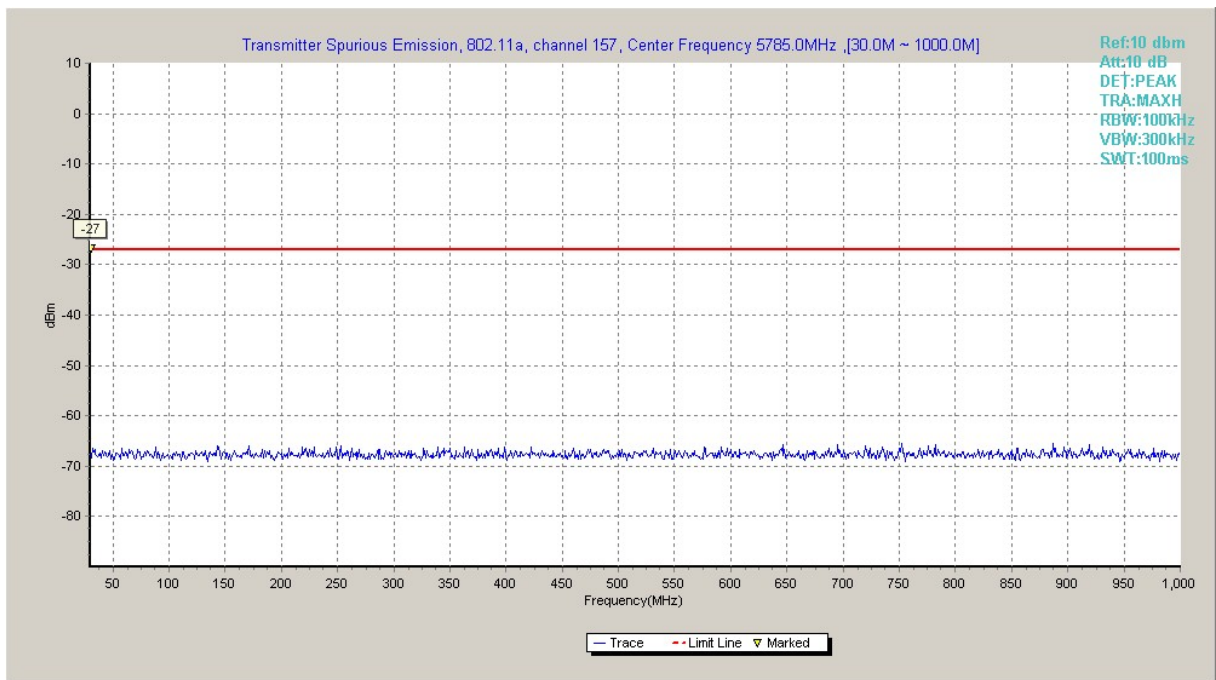

Fig. 19 Conducted Spurious Emission (802.11a, Ch157, 30 MHz-1 GHz)

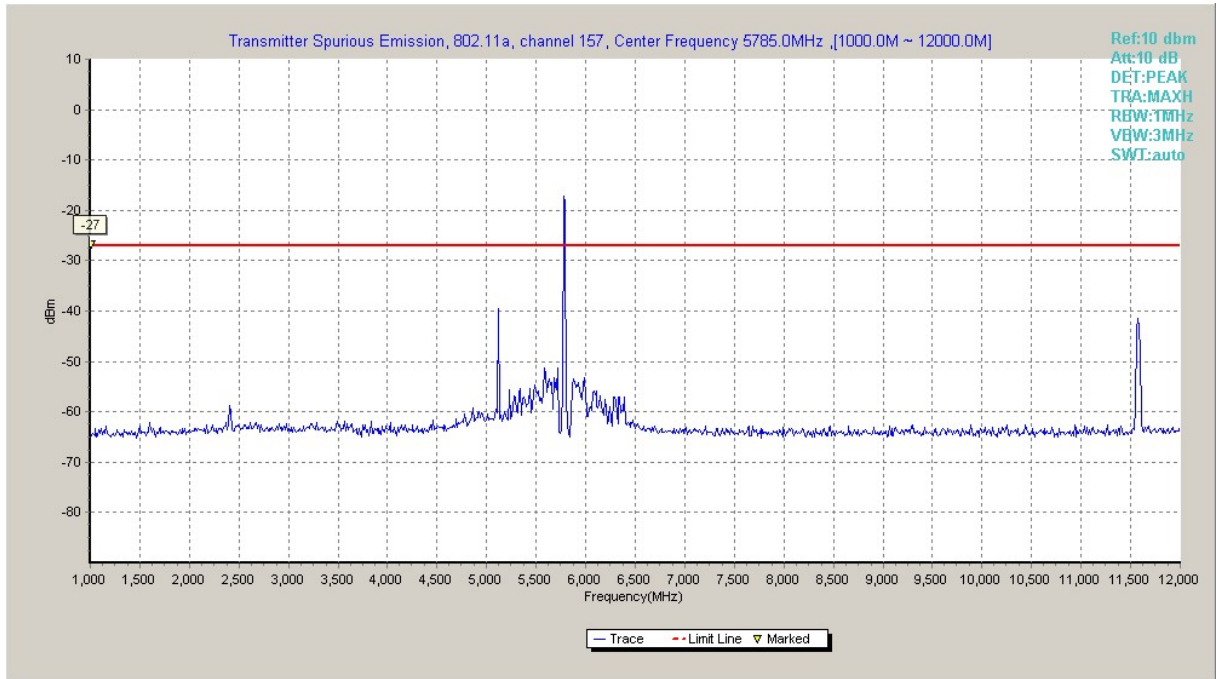

Fig. 20 Conducted Spurious Emission (802.11a, Ch157, 1 GHz -12 GHz)

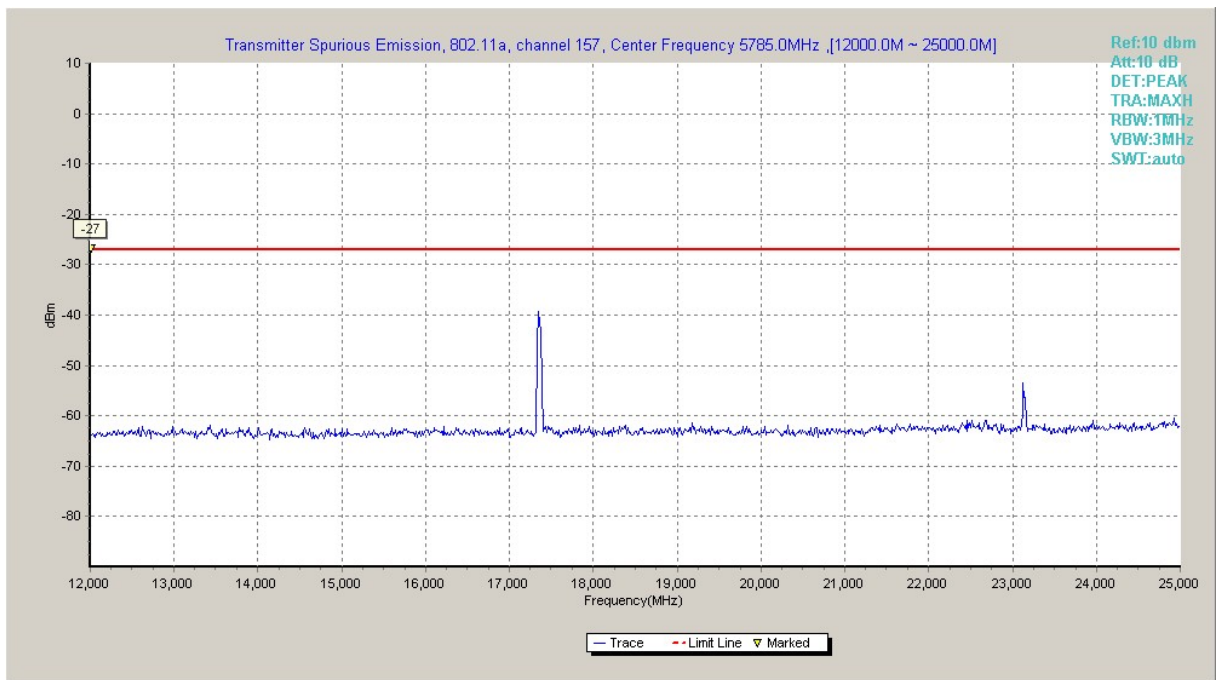

Fig. 21 Conducted Spurious Emission (802.11a, Ch157, 12 GHz-25 GHz)

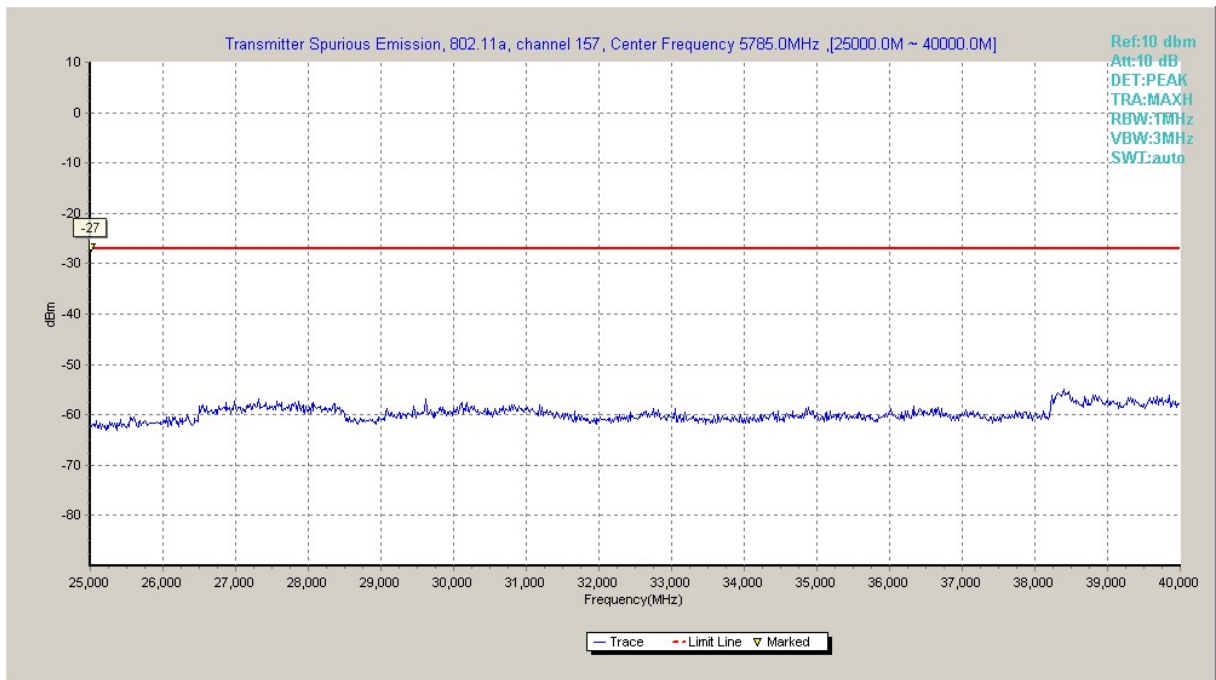

Fig. 22 Conducted Spurious Emission (802.11a, Ch157, 25 GHz-40 GHz)

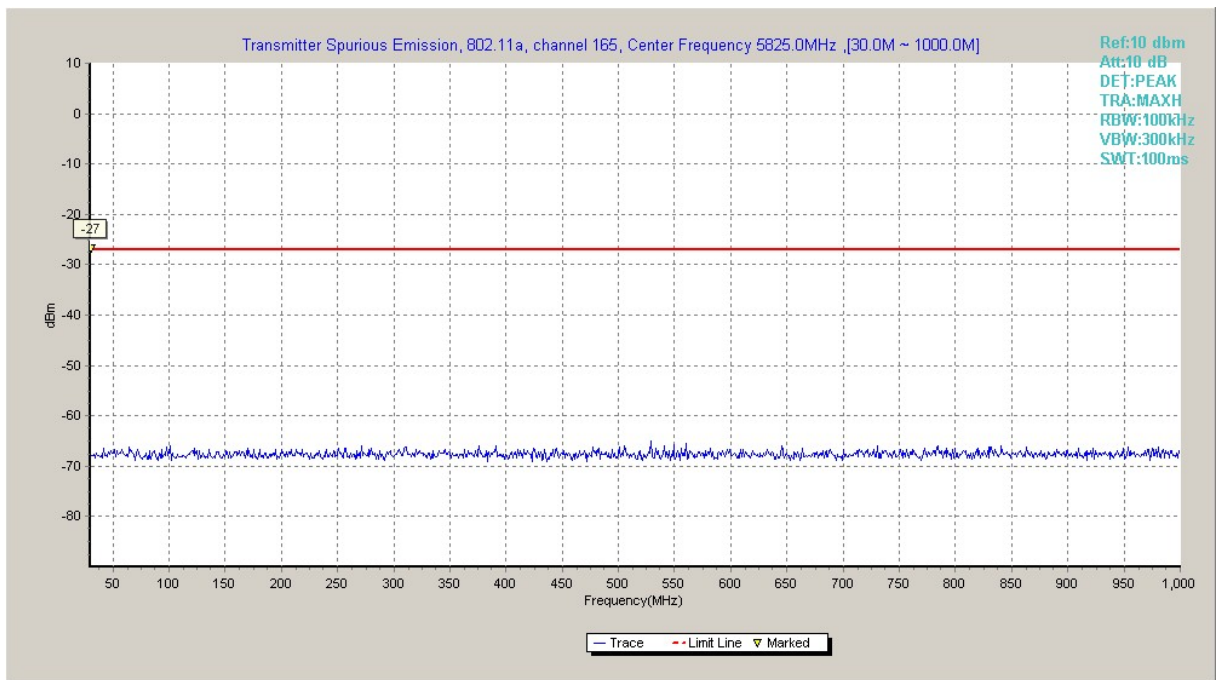

Fig. 23 Conducted Spurious Emission (802.11a, Ch165, 30 MHz-1 GHz)

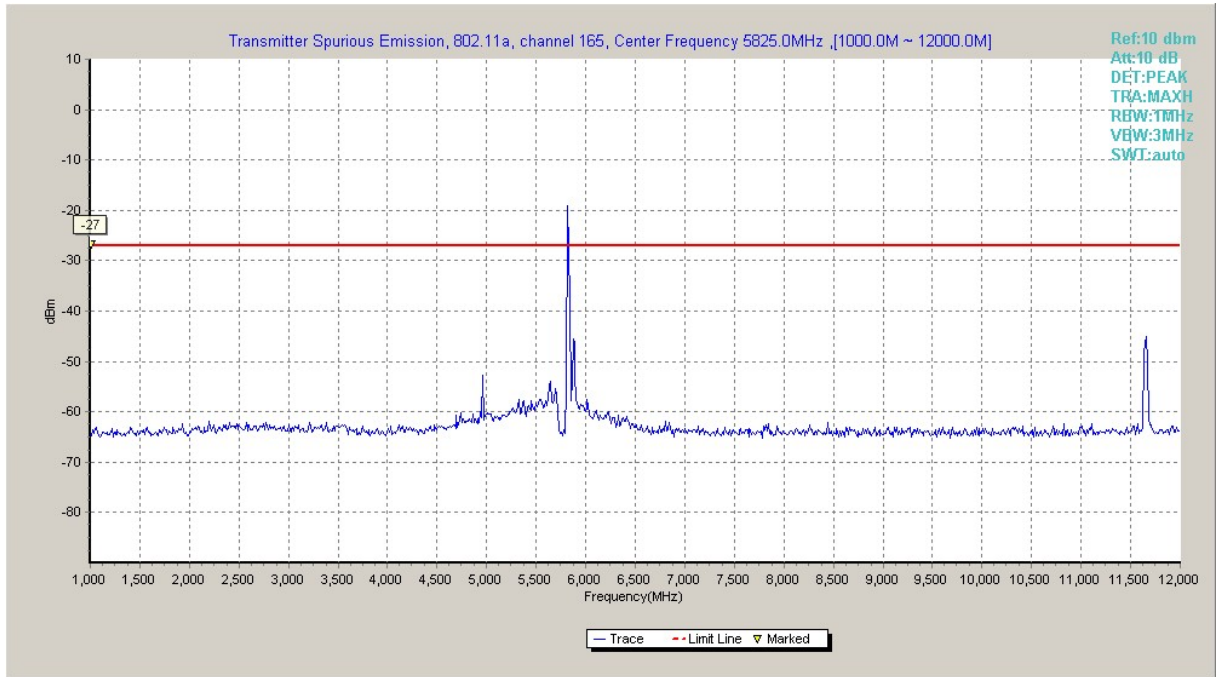

Fig. 24 Conducted Spurious Emission (802.11a, Ch165, 1 GHz -12 GHz)

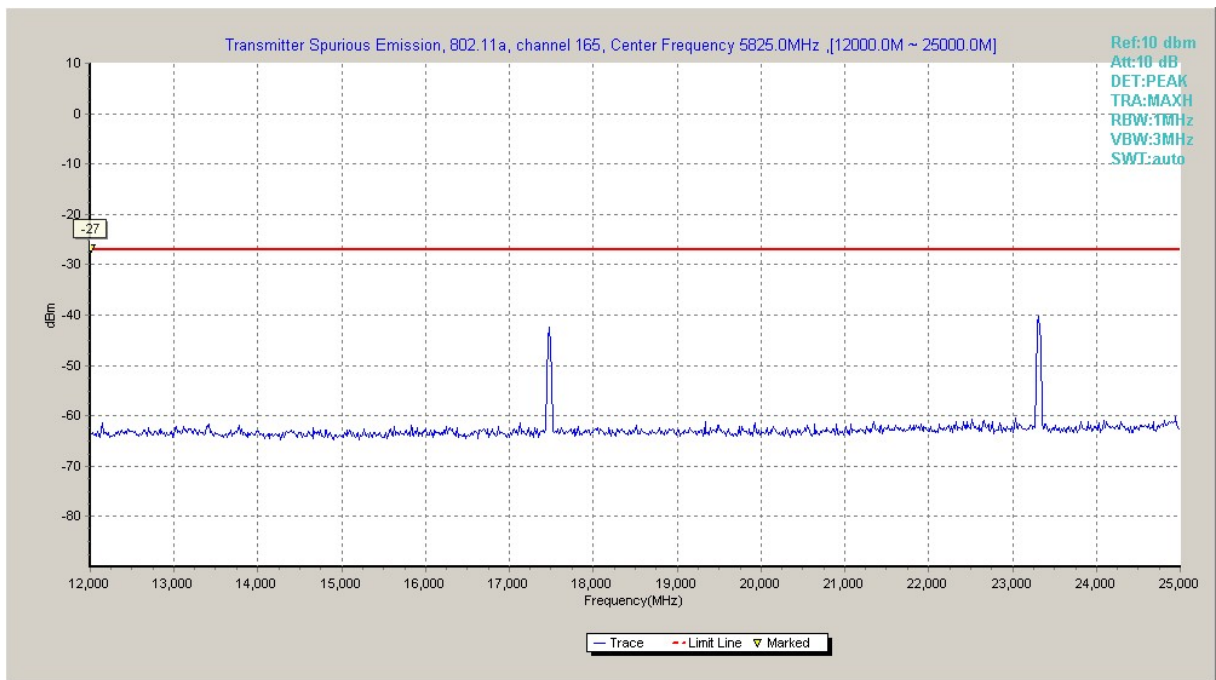

Fig. 25 Conducted Spurious Emission (802.11a, Ch165, 12 GHz-25 GHz)

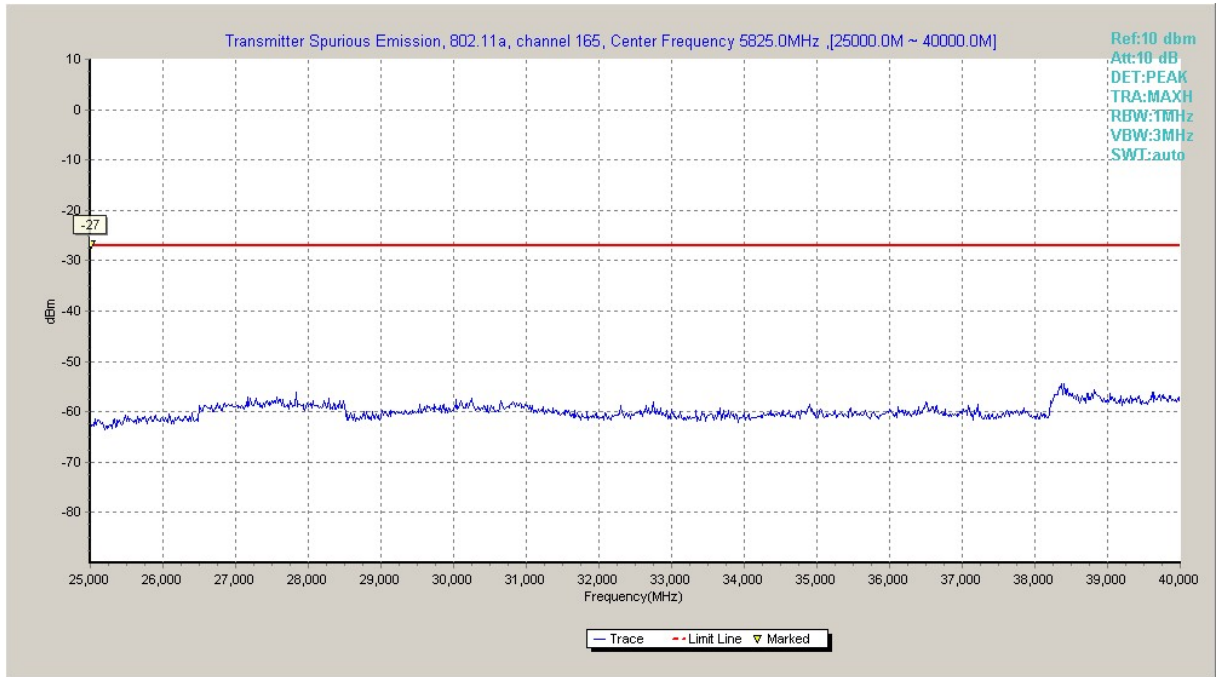

Fig. 26 Conducted Spurious Emission (802.11a, Ch165, 25 GHz-40 GHz)

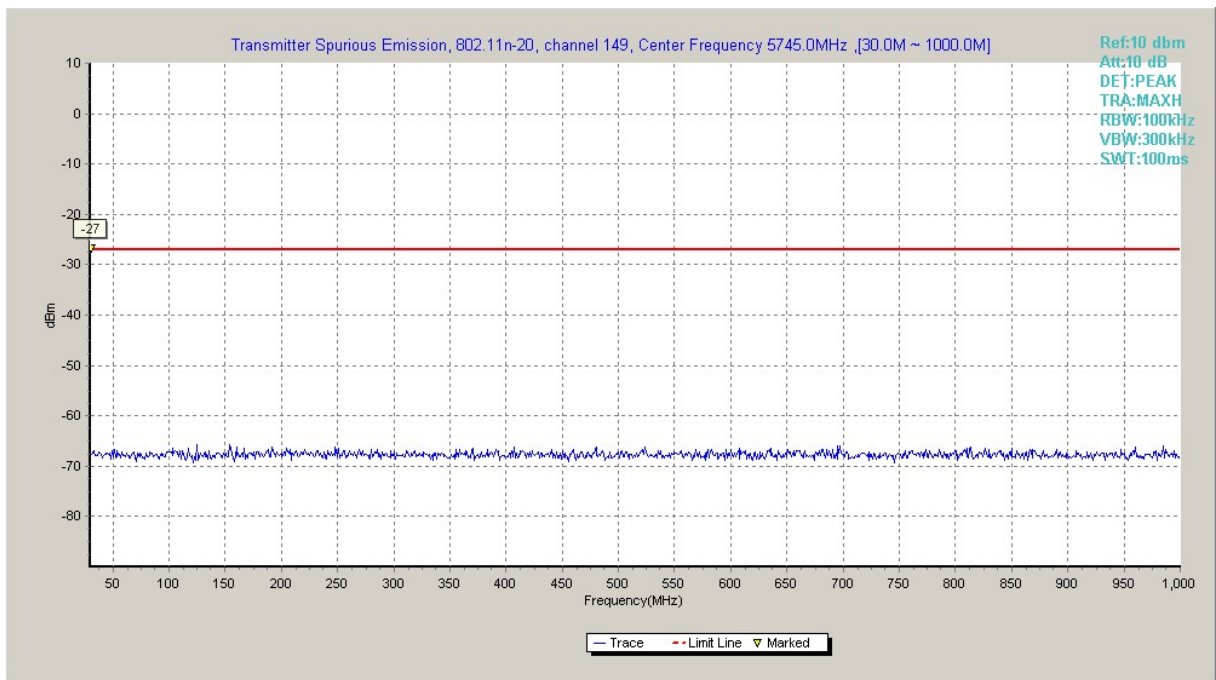

Fig. 27 Conducted Spurious Emission (802.11n-HT20, Ch149, 30 MHz-1 GHz)

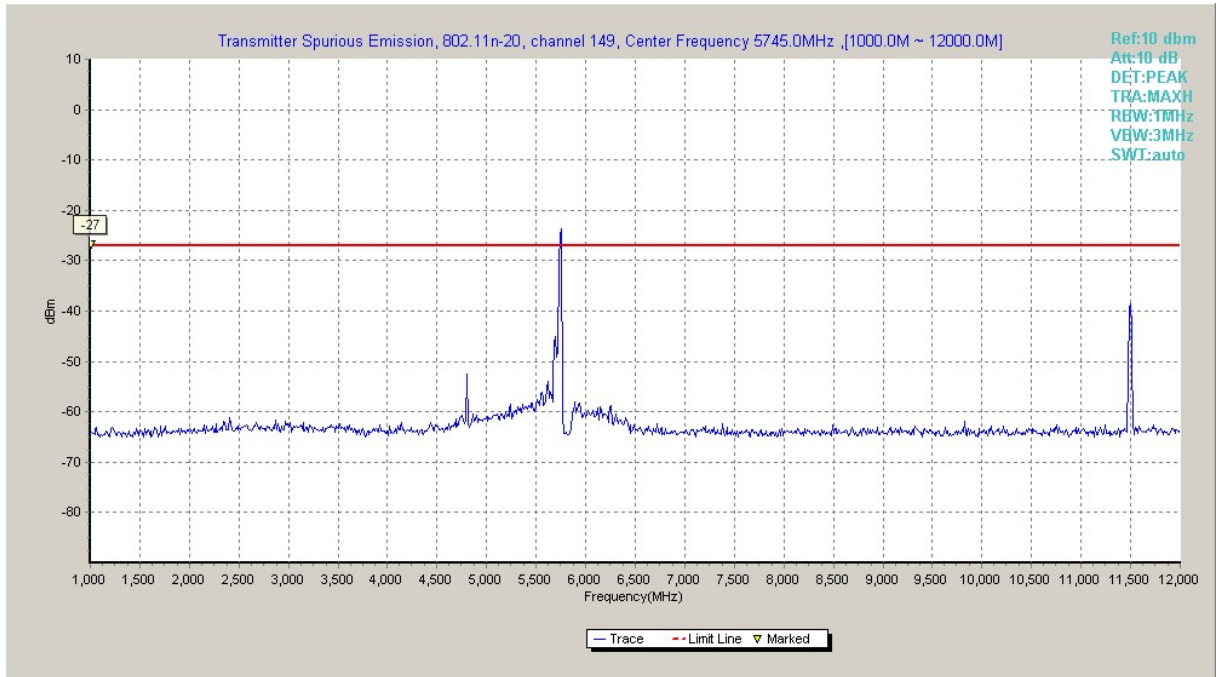

Fig. 28 Conducted Spurious Emission (802.11n-HT20, Ch149, 1 GHz -12 GHz)

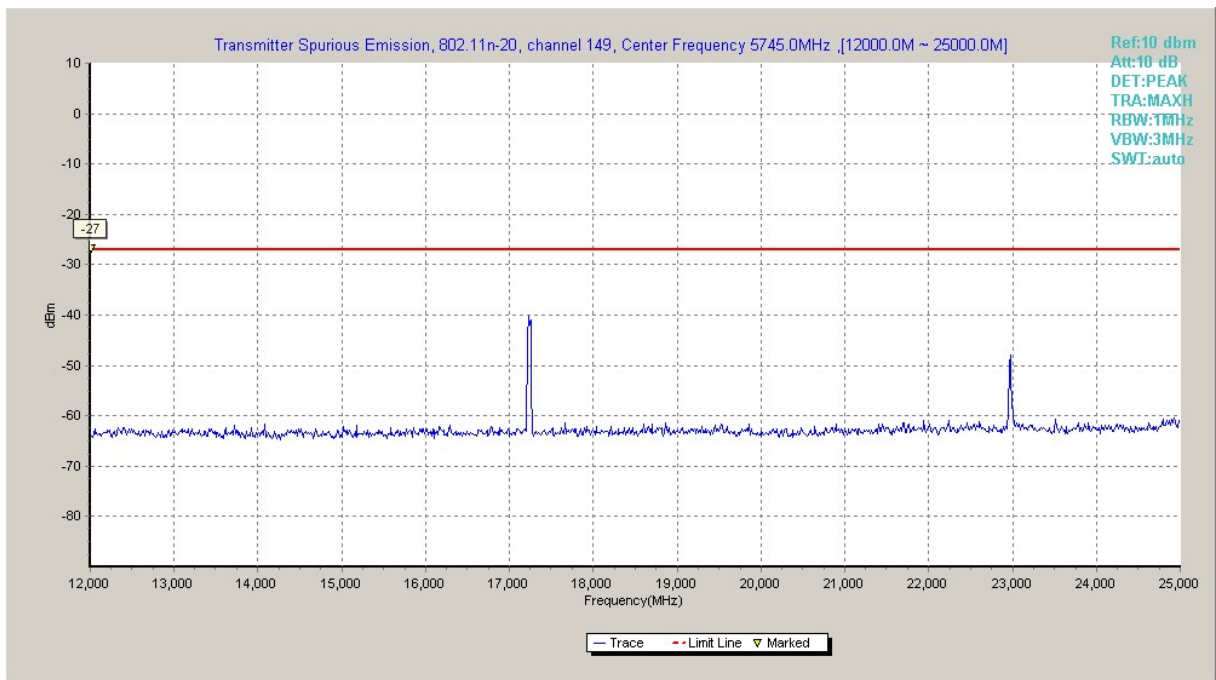

Fig. 29 Conducted Spurious Emission (802.11n-HT20, Ch149, 12 GHz-25 GHz)

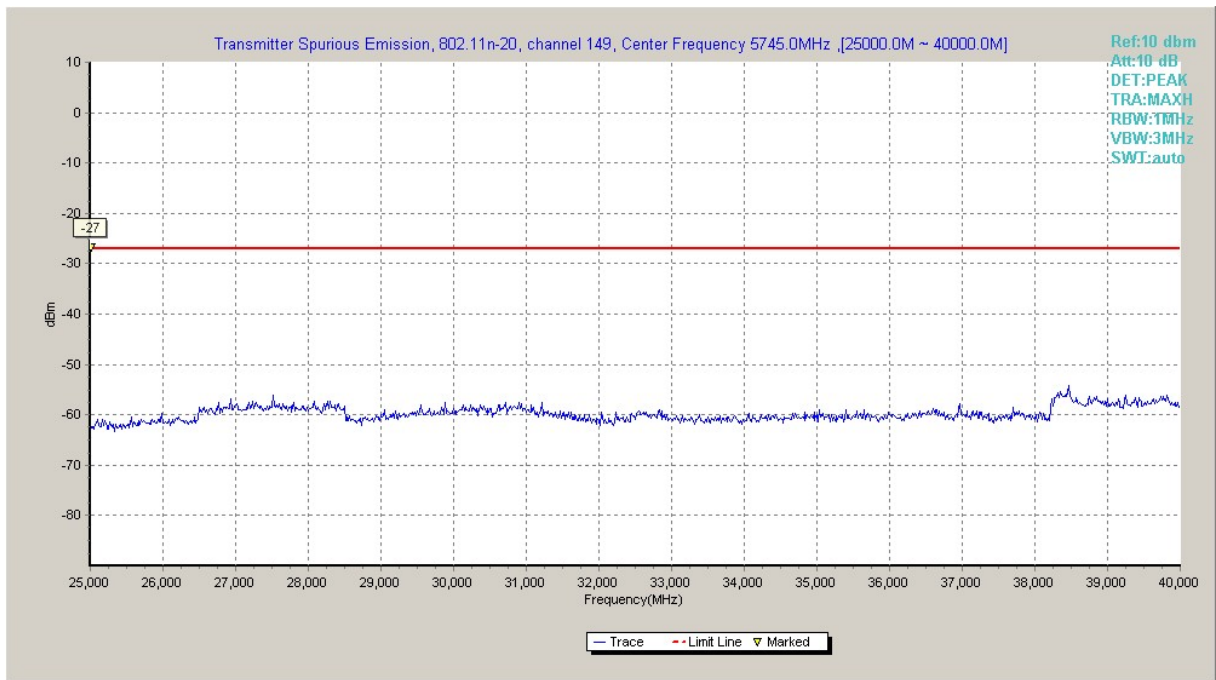

Fig. 30 Conducted Spurious Emission (802.11n-HT20, Ch149, 25 GHz-40 GHz)

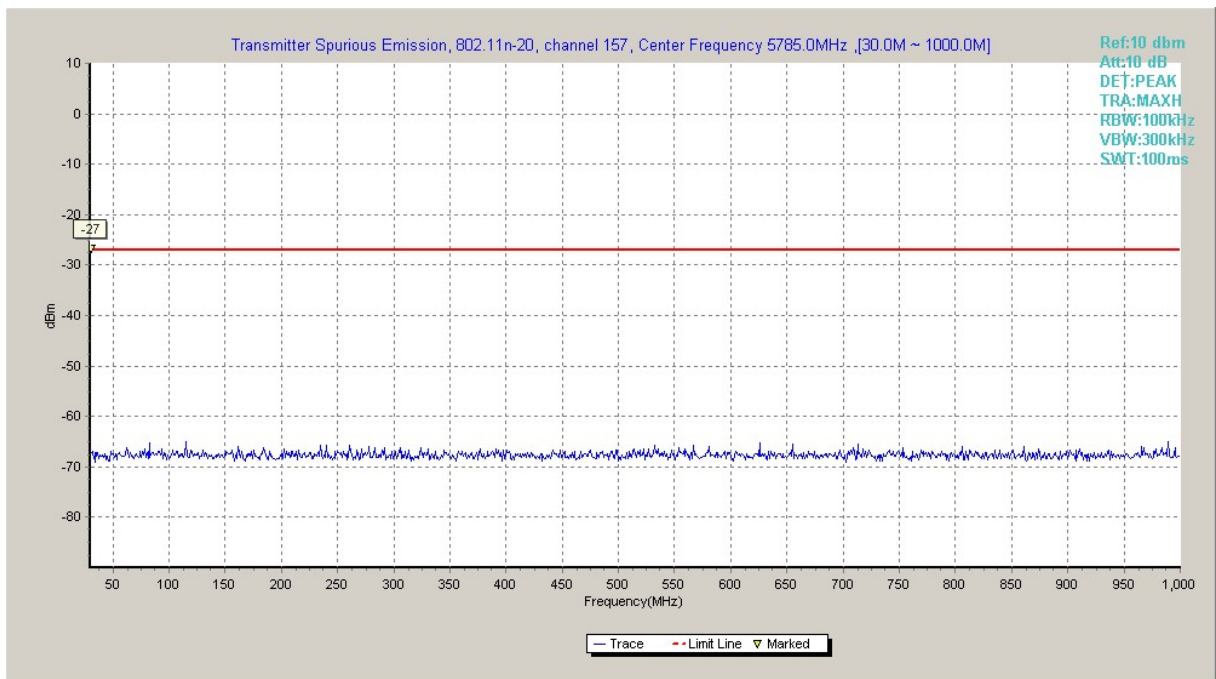

Fig. 31 Conducted Spurious Emission (802.11n-HT20, Ch157, 30 MHz-1 GHz)

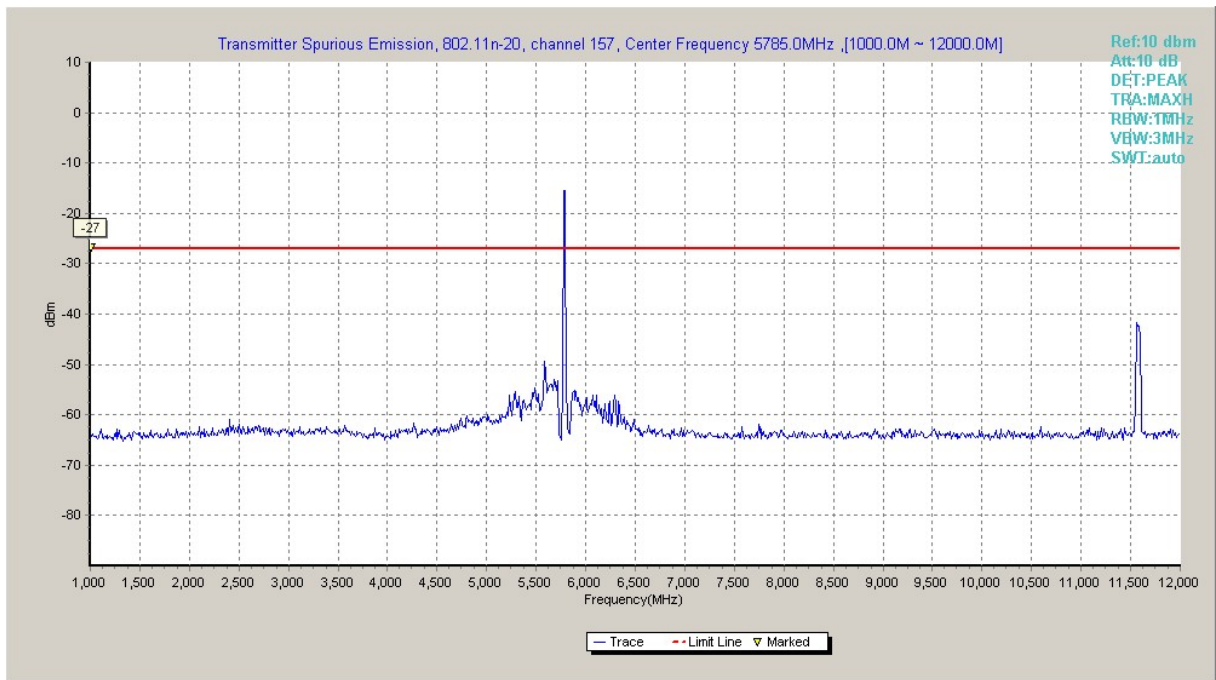

Fig. 32 Conducted Spurious Emission (802.11n-HT20, Ch157, 1 GHz -12 GHz)

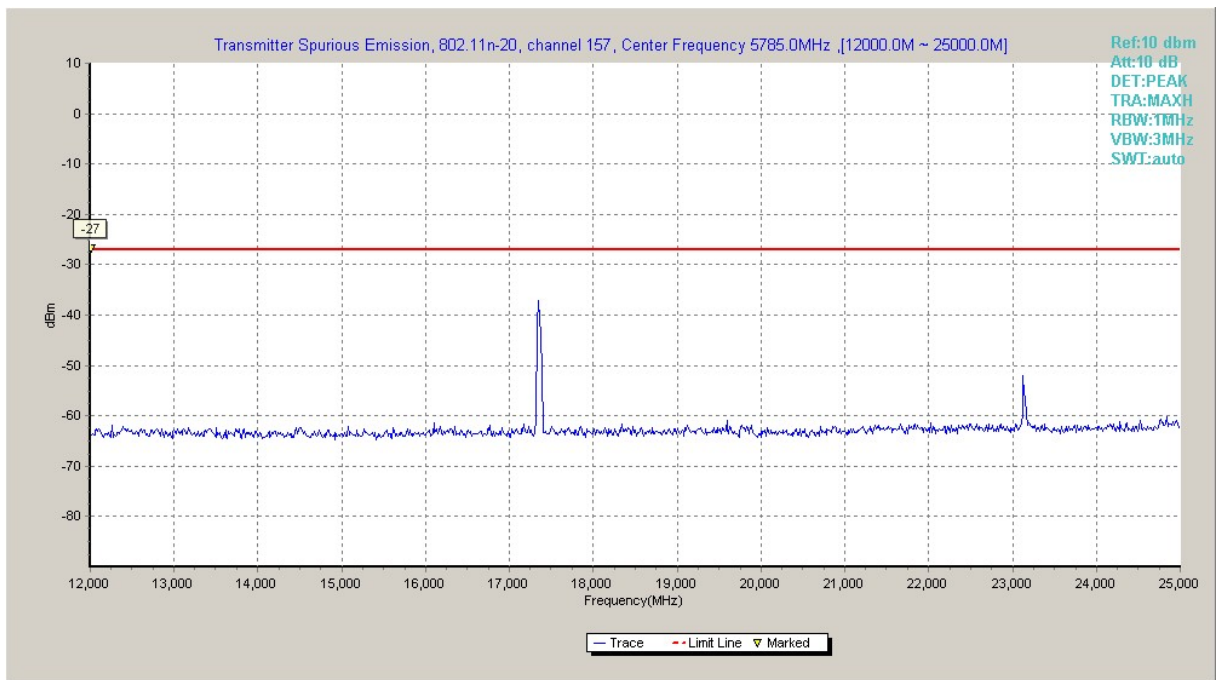

Fig. 33 Conducted Spurious Emission (802.11n-HT20, Ch157, 12 GHz-25 GHz)

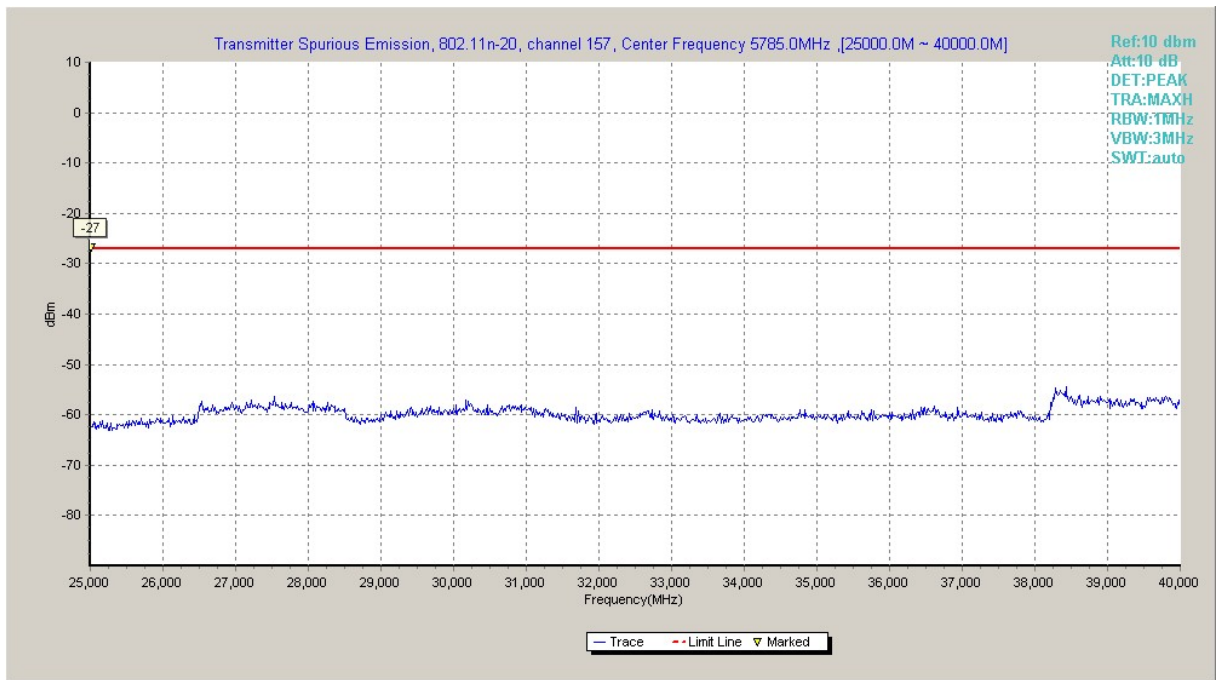

Fig. 34 Conducted Spurious Emission (802.11n-HT20, Ch157, 25 GHz-40 GHz)

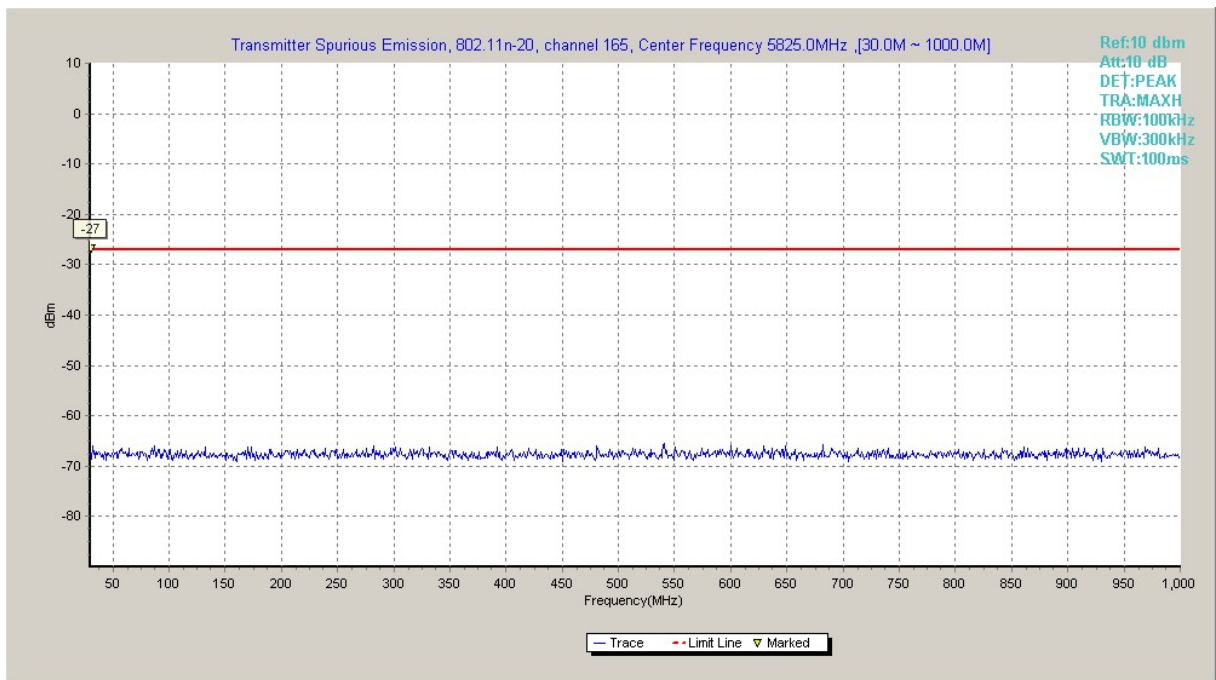

Fig. 35 Conducted Spurious Emission (802.11n-HT20, Ch165, 30 MHz-1 GHz)

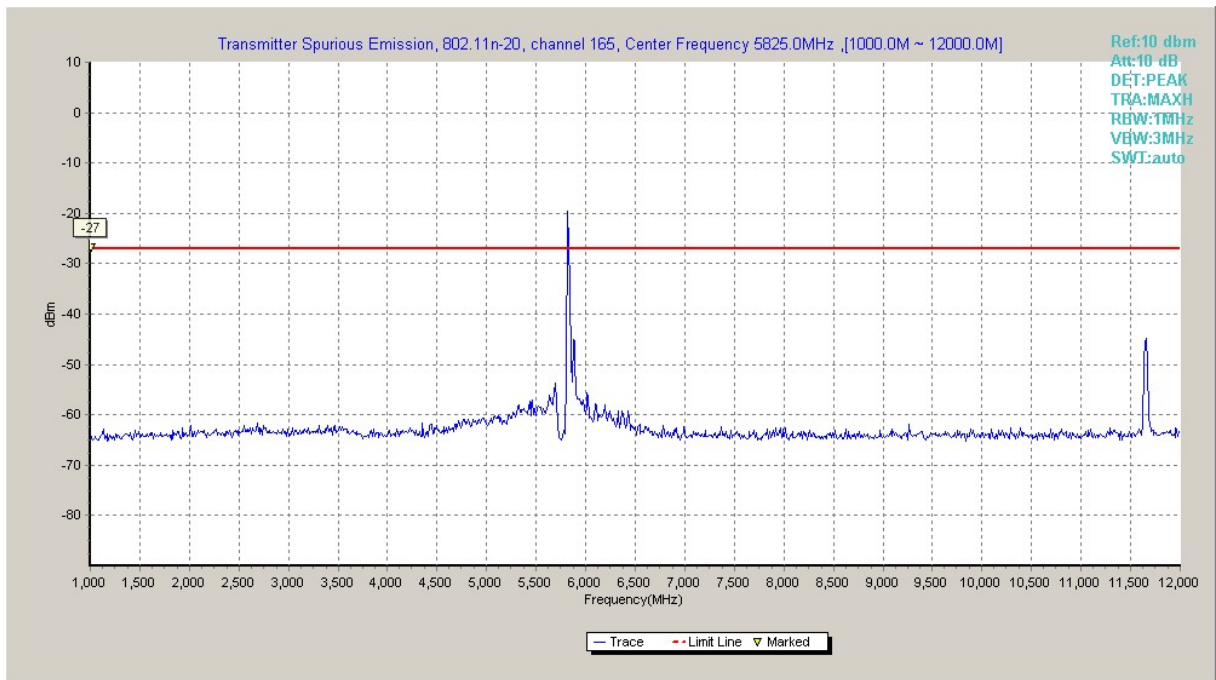

Fig. 36 Conducted Spurious Emission (802.11n-HT20, Ch165, 1 GHz -12 GHz)

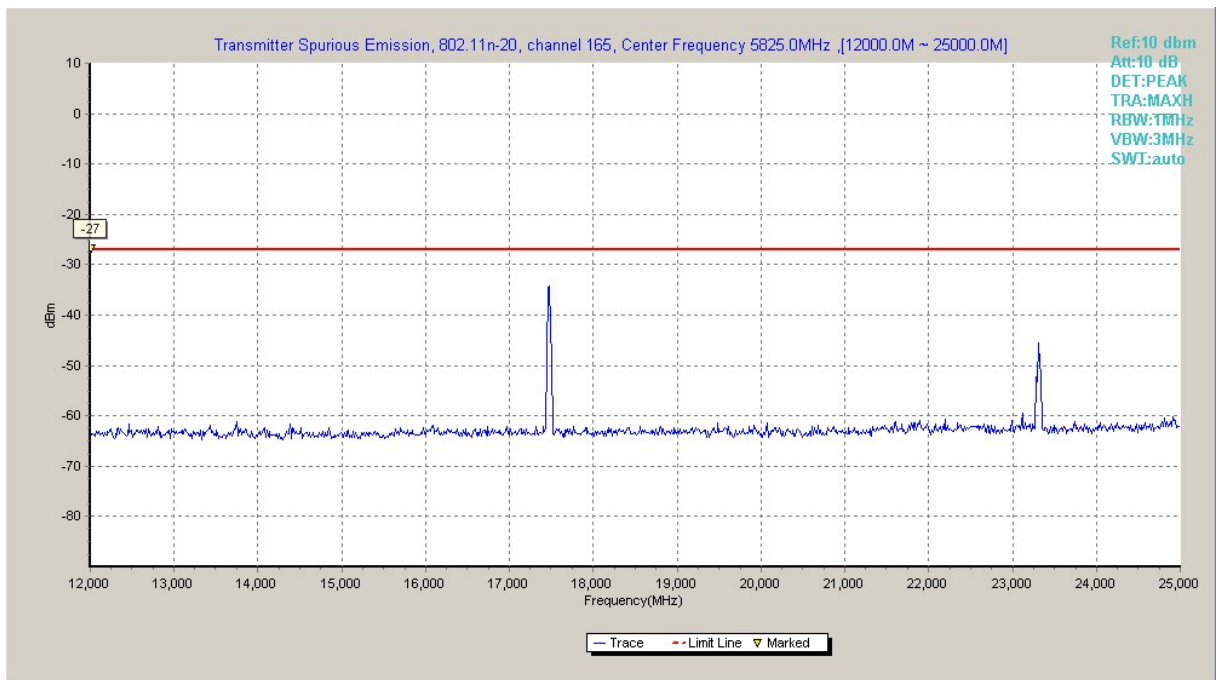

Fig. 37 Conducted Spurious Emission (802.11n-HT20, Ch165, 12 GHz-25 GHz)

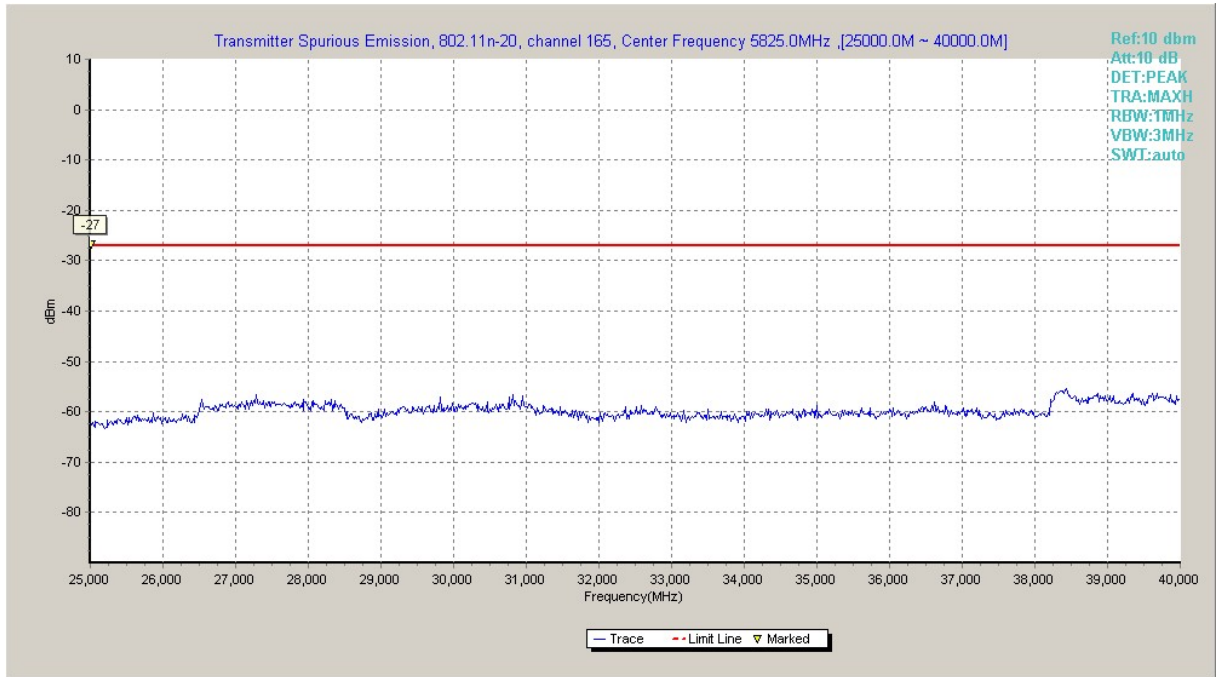

Fig. 38 Conducted Spurious Emission (802.11n-HT20, Ch165, 25 GHz-40 GHz)

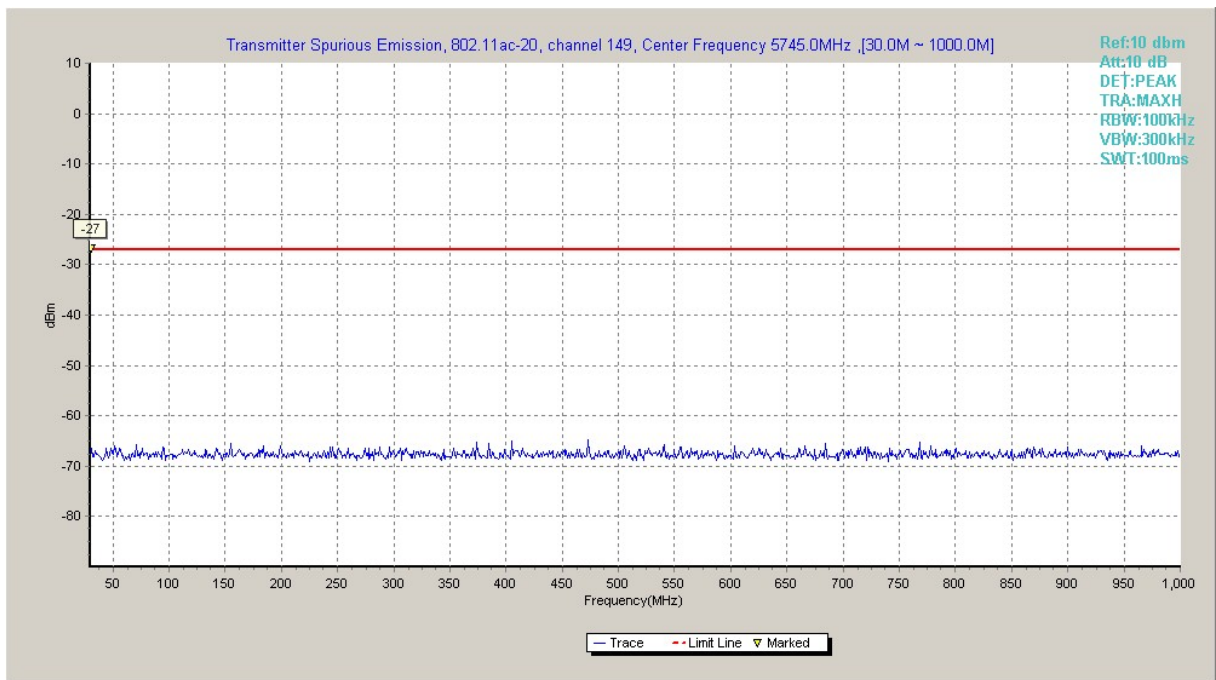

Fig. 39 Conducted Spurious Emission (802.11ac-HT20, Ch149, 30 MHz-1 GHz)

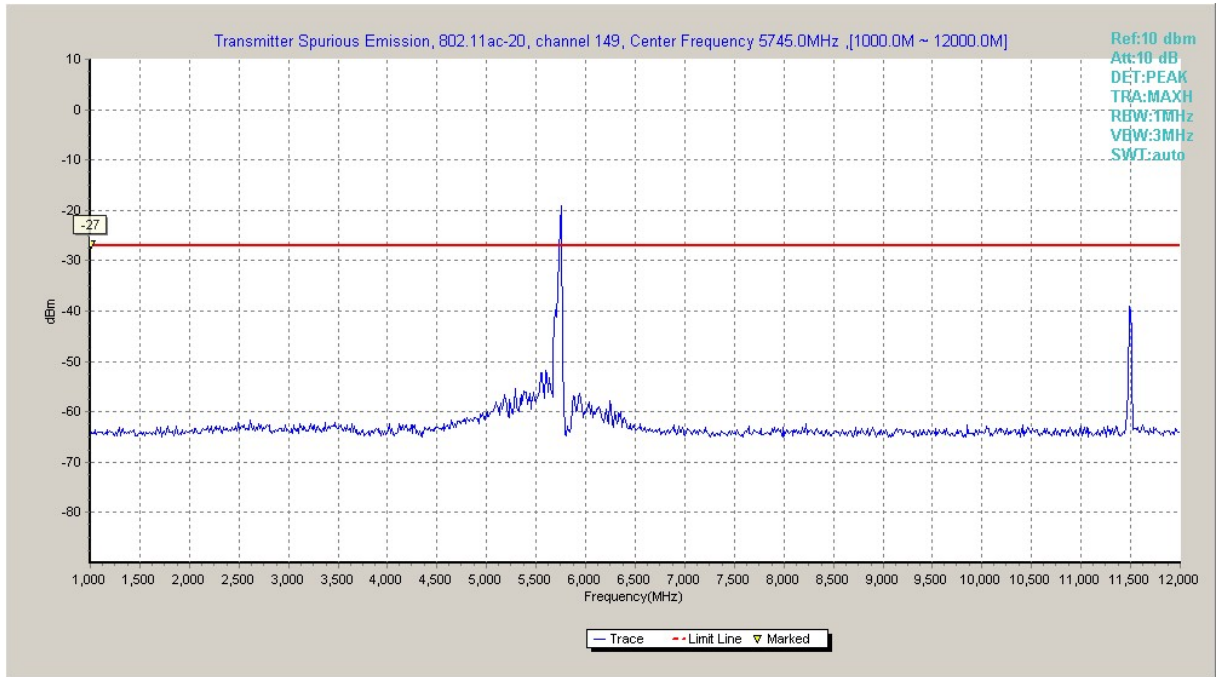

Fig. 40 Conducted Spurious Emission (802.11ac-HT20, Ch149, 1 GHz -12 GHz)

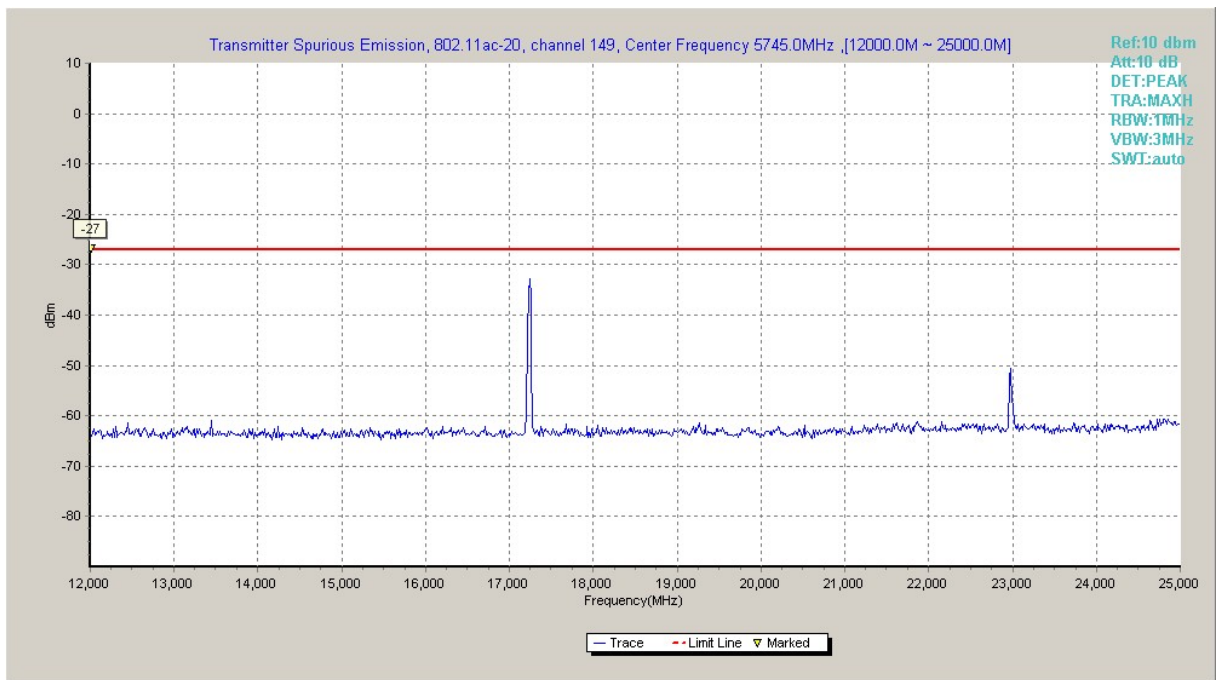

Fig. 41 Conducted Spurious Emission (802.11ac-HT20, Ch149, 12 GHz-25 GHz)

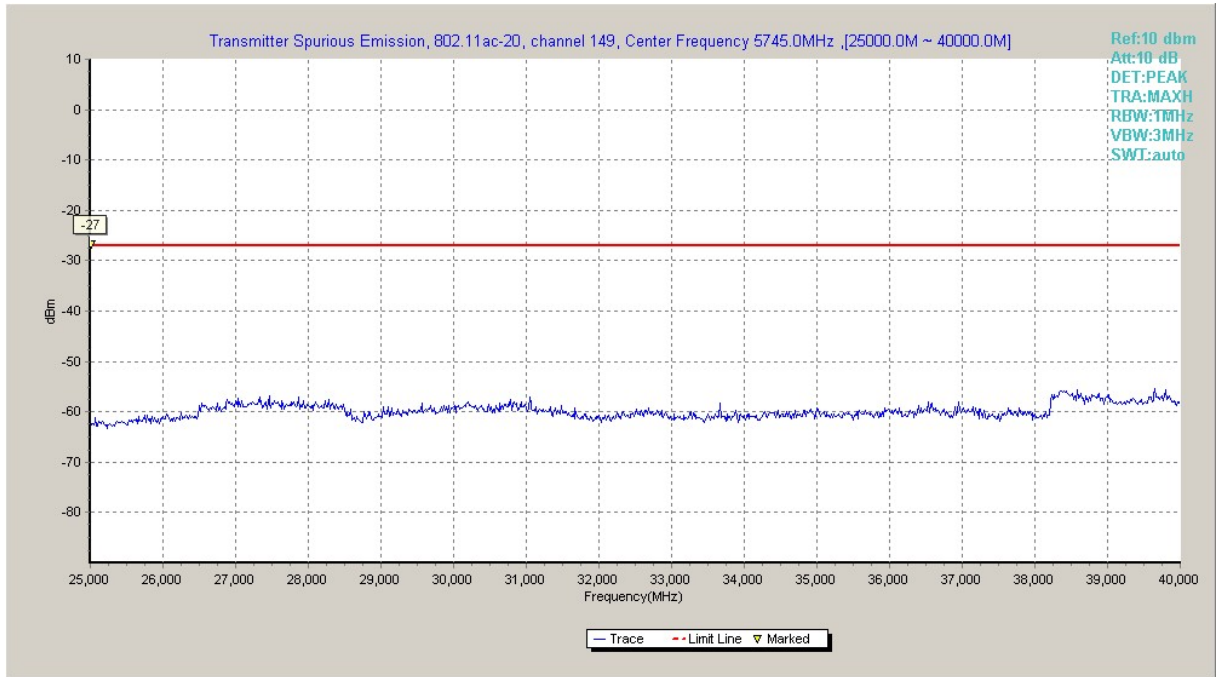

Fig. 42 Conducted Spurious Emission (802.11ac-HT20, Ch149, 25 GHz-40 GHz)

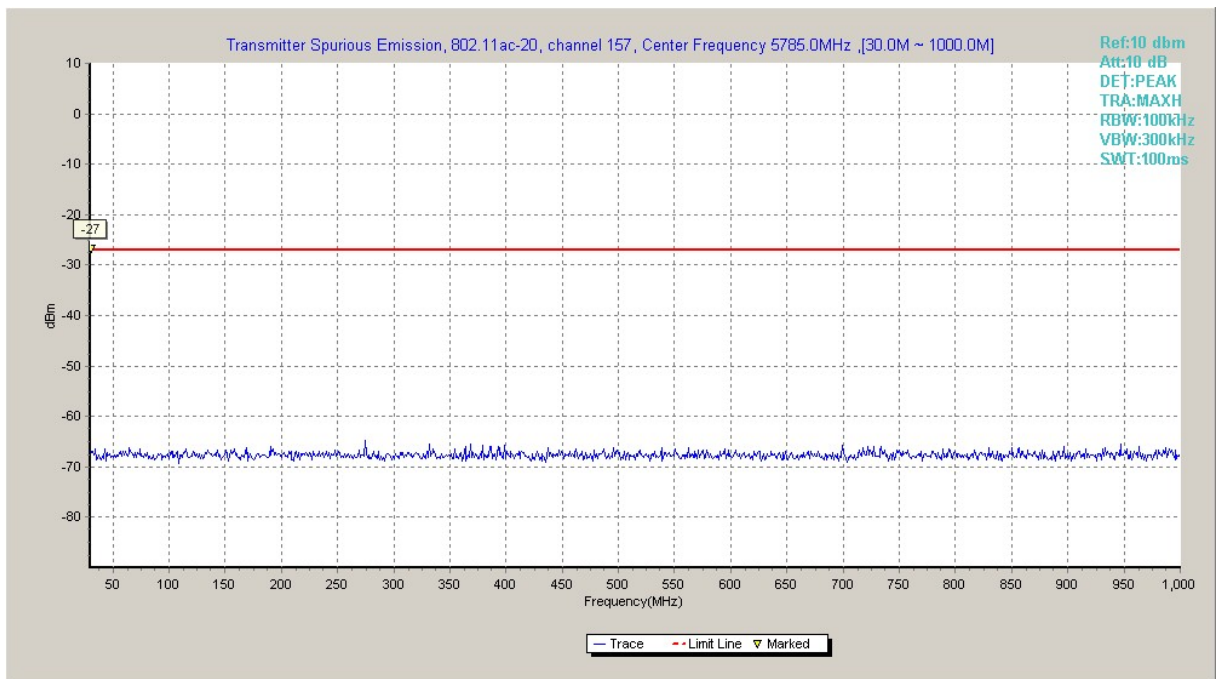

Fig. 43 Conducted Spurious Emission (802.11ac-HT20, Ch157, 30 MHz-1 GHz)