



FCC PART 15C TEST REPORT No.23T04Z70647-15

for

Samsung Electronics Co., Ltd.

Notebook PC

**Model Name: NP750XGL,NP750XGP,NP751XGL,
NP751XGP,NP754XGL,NP754XGP,NP750XGK,NP750XGQ,NP754XGK,
NP751XGK,NP751XGQ,NP754XGQ**

With

FCC ID: ZCANP750XGL

Hardware Version: REV1.0

Software Version: Windows 11

Issued Date: 2024-01-16

Note:

The test results in this test report relate only to the devices specified in this report. This report shall not be reproduced except in full without the written approval of CTTL.

Test Laboratory:

CTTL, Telecommunication Technology Labs, CAICT

No.52, HuayuanNorth Road, Haidian District, Beijing, P. R. China 100191.

Tel:+86(0)10-62304633-2512,Fax:+86(0)10-62304633-2504

Email:cttl_terminals@caict.ac.cn, website: www.chinattl.com

©Copyright. All rights reserved by CTTL.



REPORT HISTORY

Report Number	Revision	Description	Issue Date
23T04Z70647-15	Rev.0	1st edition	2024-01-16

CONTENTS

1. TEST LABORATORY	4
1.1. INTRODUCTION & ACCREDITATION	4
1.2. TESTING LOCATION	4
1.3. TESTING ENVIRONMENT	4
1.4. PROJECT DATA	4
1.5. SIGNATURE	4
2. CLIENT INFORMATION.....	5
2.1. APPLICANT INFORMATION	5
2.2. MANUFACTURER INFORMATION	5
3. PRODUCT INFORMATION	6
3.1. ABOUT EUT	6
3.2. INTERNAL IDENTIFICATION OF EUT	6
3.3. INTERNAL IDENTIFICATION OF AE.....	6
3.4. GENERAL DESCRIPTION.....	7
3.5. TEST CONFIGURATION	7
3.6. INTERPRETATION OF THE TEST ENVIRONMENT.....	7
4. REFERENCE DOCUMENTS.....	8
4.1. DOCUMENTS SUPPLIED BY APPLICANT	8
4.2. REFERENCE DOCUMENTS FOR TESTING.....	8
5. TEST RESULTS	9
5.1. SUMMARY OF TEST RESULTS	9
5.2. STATEMENTS.....	9
5.3. TEST CONDITIONS	9
6. TEST FACILITIES UTILIZED.....	10
7. MEASUREMENT UNCERTAINTY	11
ANNEX A: EUT PARAMETERS	12
ANNEX B: ANTENNA REQUIREMENTS	12
ANNEX C: DETAILED TEST RESULTS.....	13
C.1. RADIATED SPURIOUS EMISSION	13
C.2. AC POWERLINE CONDUCTED EMISSION	33

1. Test Laboratory

1.1. Introduction & Accreditation

Telecommunication Technology Labs, CAICT is an ISO/IEC 17025:2017 accredited test laboratory under American Association for Laboratory Accreditation (A2LA) with lab code 7049.01, and is also an FCC accredited test laboratory (CN1349), and ISED accredited test laboratory (CAB identifier:CN0066). The detail accreditation scope can be found on A2LA website.

1.2. Testing Location

Location: CTTL (Huayuan North Road)

Address: No. 52 Huayuan North Road, Haidian District, Beijing 100191, P.R. China

1.3. Testing Environment

Normal Temperature: 15-35°C

Relative Humidity: 20-75%

1.4. Project data

Testing Start Date: 2023-12-23

Testing End Date: 2024-01-04

1.5. Signature



Wang Xue

(Prepared this test report)



Zhang Ying

(Reviewed this test report)



Zhang Xia

Deputy Director of the laboratory

(Approved this test report)



2. Client Information

2.1. Applicant Information

Company Name: Samsung Electronics Co., Ltd.
Address: 19 Chapin Rd., Building D Pine Brook, NJ 07058
Contact: Jenni Chun
Email: j1.chun@samsung.com
Telephone: +1-201-937-4203
Fax: /

2.2. Manufacturer Information

Company Name: Samsung Electronics Co., Ltd.
Address: Samsung R5, Maetan dong 129, Samsung ro Youngtong gu, Suwon city 443 742, Korea
Contact: Minji Son
Email: minji28.son@samsung.com
Telephone: +82-10-3130-2080
Fax: /

3. PRODUCT INFORMATION

3.1. About EUT

Description	Notebook PC
Model name	NP750XGL,NP750XGP,NP751XGL,NP751XGP,NP754XGL,NP754XGP,NP750XGK,NP750XGQ,NP754XGK,NP751XGK,NP751XGQ,NP754XGQ
FCC ID	ZCANP750XGL

Note: Components list, please refer to documents of the manufacturer; it is also included in the original test record of T CTTL-Telecommunication Technology Labs, CAICT

3.2. Internal Identification of EUT

EUT ID*	SN or IMEI	HW Version	SW Version
EUT1	2370647UT11a	REV1.0	Windows 11
EUT2	2370647UT21a	REV1.0	Windows 11

*EUT ID: is used to identify the test sample in the lab internally.

3.3. Internal Identification of AE

AE ID*	Description	SN	Remarks
AE1	Travel Adapter	/	/
AE2	Travel Adapter	/	/
AE3	battery	/	/

AE1

Model	/
Manufacturer	SOLUM CO.,LTD.
Length of cable	/

AE2

Model	/
Manufacturer	DONGYANG
Length of cable	/

AE3

Model	/
Manufacturer	/

*AE ID: is used to identify the test sample in the lab internally.

3.4. General Description

The Equipment under Test (EUT) was a Notebook PC with Bluetooth, Bluetooth Low Energy and 802.11 a/b/g/n/ac/ax capabilities in the 2.4 GHz and 5 GHz bands.

Manual and specifications of the EUT were provided to fulfil the test.

Samples undergoing test were selected by the Client.

For more EUT information please refer to the manufacturer's specifications or user's manual.

3.5. Test Configuration

Test Mode	Transmitting Frequency (MHz)		
GFSK	2402(CH0)	2441 (CH39)	2480 (CH78)
$\pi/4$ DQPSK	2402(CH0)	2441 (CH39)	2480 (CH78)
8DPSK	2402(CH0)	2441 (CH39)	2480 (CH78)

For Bluetooth mode the EUT can transmit only at CHAIN A RF output.

The software DRTU provided by client to enable the EUT under transmission condition continuously at specific channel frequencies individually.

3.6. Interpretation of the Test Environment

For the test methods, the test environment uncertainty figures correspond to an expansion factor $k=2$.

Measurement Uncertainty

Parameter	Uncertainty
temperature	0.48°C
humidity	2 %
DC voltages	0.003V

4. Reference Documents

4.1. Documents supplied by applicant

EUT parameters, referring to Annex A for detailed information, is supplied by the client or manufacturer, which is the basis of testing.

4.2. Reference Documents for testing

The following documents listed in this section are referred for testing.

Reference	Title	Version
FCC Part15	FCC CFR 47, Part 15, Subpart C: 15.205 Restricted bands of operation; 15.209 Radiated emission limits, general requirements; 15.247 Operation within the bands 902-928MHz, 2400-2483.5 MHz, and 5725-5850 MHz.	2021
ANSI C63.10	American National Standard of Procedures for Compliance Testing of Unlicensed Wireless Devices Federal Communications Commission Office of Engineering and Technology Laboratory Division GUIDANCE FOR COMPLIANCE MEASUREMENTS ON	2013
KDB 558074 D01	DIGITAL TRANSMISSION SYSTEM, FREQUENCY HOPPING SPREAD SPECTRUM SYSTEM, AND HYBRID SYSTEM DEVICES OPERATING UNDER SECTION 15.247 OF THE FCC RULES	2019

Note: The test methods have no deviation with standards.

5. Test Results

5.1. Summary of Test Results

Abbreviations used in this clause:

- P** Pass, The EUT complies with the essential requirements in the standard.
- F** Fail, The EUT does not comply with the essential requirements in the standard
- NA** Not Applicable, The test was not applicable
- NP** Not Performed, The test was not performed by CTTL

SUMMARY OF MEASUREMENT RESULTS	Sub-clause of Part15C	Verdict
Radiated Spurious Emission	15.247, 15.205, 15.209	P
AC Power line Conducted Emission	15.107, 15.207	P

Please refer to **ANNEX C** for detail.

The measurement is made according to ANSI C63.10.

Note: the other RF conducted test items are included in test report number: BL-SZ23A0865-601, which issued by Shenzhen BALUN Technology Co., Ltd. on Jan.15, 2024

5.2. Statements

CTTL has evaluated the test cases requested by the applicant /manufacturer as listed in section 5.1 of this report for the EUT specified in section 3 according to the standards or reference documents listed in section 4.2

5.3. Test Conditions

T nom	Normal Temperature
T min	Low Temperature
T max	High Temperature
V nom	Normal Voltage

For this report, if the test cases listed above are tested under normal temperature and normal voltage, and also under norm humidity, the specific condition is shown as follows:

Temperature	T nom	15-35℃
Voltage	V nom	15.4V
Humidity	H nom	20-75%

6. Test Facilities Utilized

Radiated emission test system

No.	Equipment	Model	Manufacturer	Serial Number	Calibration Period	Calibration Due date
1	Test Receiver	ESW44	R&S	103023	13 Months	2024-07-08
2	EMI Antenna	VULB 9163	SCHWARZBECK	01222	13 Months	2024-02-28
3	EMI Antenna	3115	ETS-Lindgren	6914	13 Months	2024-06-07
4	EMI Antenna	3116	ETS-Lindgren	2661	13 Months	2024-02-28

AC Power Line Conducted Emission

No.	Equipment	Model	Manufacturer	Serial Number	Calibration Period	Calibration Due date
1	LISN	ENV216	R&S	101200	1 year	2024-06-05
2	Test Receiver	ESCI	R&S	100344	1 year	2024-02-21

7. Measurement Uncertainty

Radiated Spurious Emission

Measurement Uncertainty:

Frequency Range	Uncertainty(dBm) (k=2)
9kHz-30MHz	4.92
$30\text{MHz} \leq f \leq 1\text{GHz}$	4.72
$1\text{GHz} \leq f \leq 18\text{GHz}$	4.84
$18\text{GHz} \leq f \leq 40\text{GHz}$	5.12

AC Power-line Conducted Emission

Measurement Uncertainty (k=2)	3.08dB
-------------------------------	--------

ANNEX A: EUT parameters

Disclaimer: The antenna gain and setting power provided by the client may affect the validity of the measurement results in this report, and the client shall bear the impact and consequences arising therefrom.

ANNEX B: Antenna Requirements

According to FCC 47 CFR § 15.203:

“An intentional radiator antenna shall be designed to ensure that no antenna other than that furnished by the responsible party can be used with the device. The use of a permanently attached antenna or of an antenna that uses a unique coupling to the intentional radiator shall be considered sufficient to comply with the provisions of this section.”

- (1) The antennas of the EUT are permanently attached.
- (2) The EUT complies with the requirement of §15.203

ANNEX C: Detailed Test Results

C.1. Radiated Spurious Emission

Specification Reference

FCC 47 CFR Part 15.247, 15.205, 15.209

Method of Measurement

The measurement is made according to ANSI C63.10

The radiated emission test is performed in semi-anechoic chamber. The EUT was placed on a non-conductive table with 80cm above the ground plane for measurement below 1GHz and 1.5m above the ground plane for measurement above 1GHz. The measurement antenna was placed at a distance of 3 meters from the EUT. The test is carried out on both vertical and horizontal polarization and only maximization result of both polarizations is kept. During the test, the turntable is rotated from 0° to 360° and the measurement antenna is moved from 1m to 4m to get the maximization result. The maximization process was repeated with the EUT positioned in each of its three orthogonal orientations.

Measurement Limit

Standard	Limit
FCC 47 CFR Part 15.247, 15.205, 15.209	20dB below peak output power

In addition, radiated emissions which fall in the restricted bands, as defined in § 15.205(a), must also comply with the radiated emission limits specified in § 15.209(a) (see § 15.205(c)).

Limit in restricted band

Frequency (MHz)	Field strength(μ V/m)	Measurement distance (m)
0.009 - 0.490	2400/F(kHz)	300
0.490 - 1.705	24000/F(kHz)	30
1.705 – 30.0	30	30

Frequency of emission (MHz)	Field strength (μ V/m)	Field strength (dBuV/m)	Measurement distance (m)
30-88	100	40	3
88-216	150	43.5	3
216-960	200	46	3
Above 960	500	54	3

Note: When performing measurements at a distance other than that specified, the results shall be extrapolated to the specified distance using an extrapolation factor.

Test setup

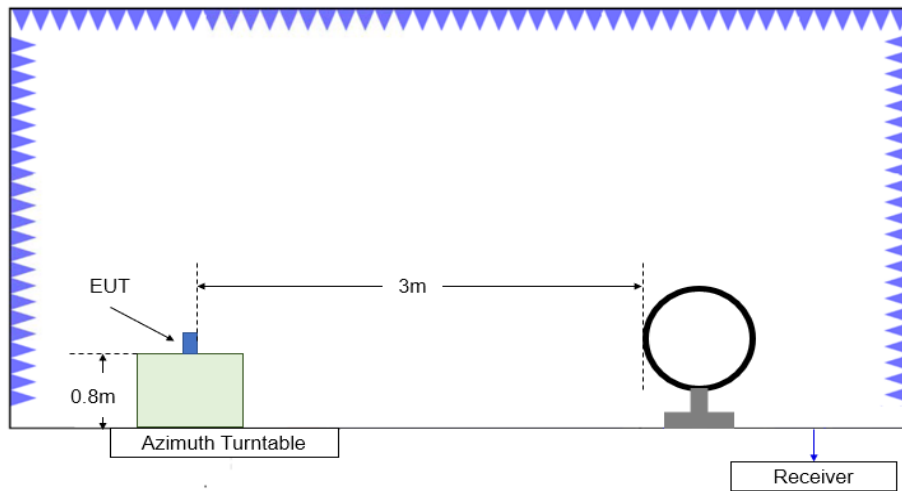

Test Site Diagram (9kHz-30MHz)

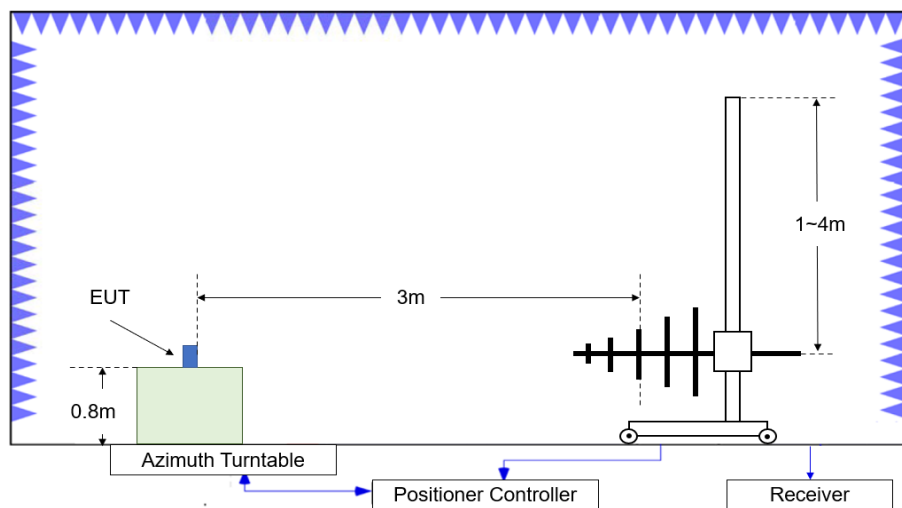

Test Site Diagram (30MHz-1GHz)

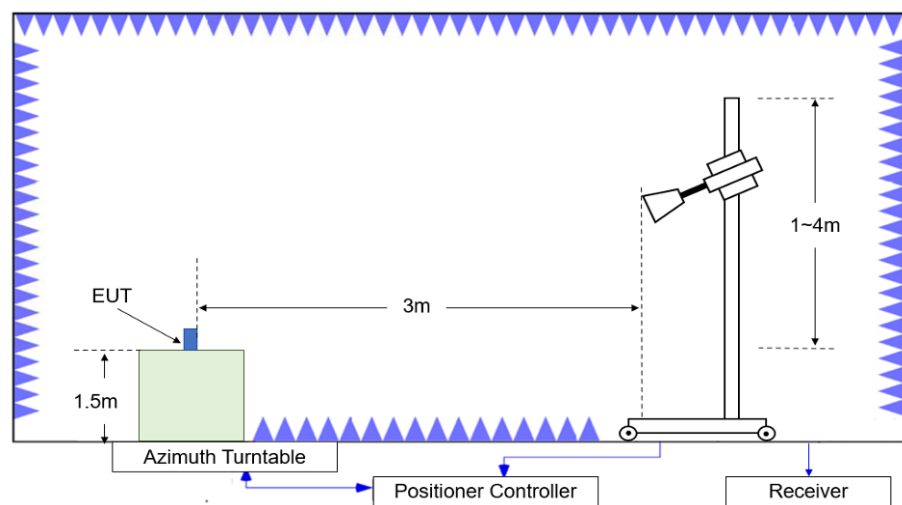

Test Site Diagram (1GHz-40GHz)

Test Procedures

Radiated unwanted emissions from the EUT were measured according to ANSI C63.10-2013 (ANSI C63.10-2020).

Test setting

Frequency of emission (MHz)	RBW/VBW	Sweep Time(s)
30-1000	100kHz/300kHz	5
1000-3000	1MHz/3MHz	15
3000-18000	1MHz/3MHz	40
18000-26500	1MHz/3MHz	20

Sample Calculation

A "reference path loss" is established and the A_{Rpl} is the attenuation of "reference path loss", and including the gain of receive antenna, the gain of the preamplifier, the cable loss.

P_{Mea} is the field strength recorded from the instrument.

The measurement results are obtained as described below:

Result= $P_{Mea}+A_{Rpl}= P_{Mea}+Cable\ Loss+Antenna\ Factor$

Test note

1. Investigation has been done on all modes and modulations/data rates. Only the radiated emissions of the configuration that produced the worst case emissions are reported in this section.
2. Spurious emissions for all channels were investigated and almost the same below 1GHz. According to FCC 47 CFR §15.31, emission levels are not report much lower than the limit by over 20dB
3. Measurement frequencies were performed from 9 kHz to the 10th harmonic of highest fundamental frequency or 40GHz, whichever is lower.

Test Result

Radiated Spurious Emission- above 1GHz

EUT ID: EUT1

Peak Measurement results

GFSK Ch 0

Frequency (MHz)	Measurement Result (dBuV/m)	Cable Loss (dB)	Antenna Factor (dB/m)	Receiver Reading (dBuV)	Limit (dBuV/m)	Margin (dB)	Antenna Pol. (H/V)
17898.500	49.46	-29.40	46.00	32.86	74.00	24.54	H
14700.000	44.87	-30.00	41.50	33.37	74.00	29.13	H
12036.000	41.80	-32.20	39.00	35.10	74.00	32.20	V
8851.000	39.59	-34.50	37.80	36.29	74.00	34.41	H
7308.000	38.05	-35.40	36.60	36.85	74.00	35.95	H
2377.200	57.13	-19.80	28.20	48.73	74.00	16.87	V

GFSK Ch 39

Frequency (MHz)	Measurement Result (dBuV/m)	Cable Loss (dB)	Antenna Factor (dB/m)	Receiver Reading (dBuV)	Limit (dBuV/m)	Margin (dB)	Antenna Pol. (H/V)
17866.500	49.09	-29.40	46.00	32.49	74.00	24.91	V
14763.000	44.56	-30.40	41.20	33.76	74.00	29.44	V
12365.000	41.78	-32.30	39.00	35.18	74.00	32.22	H
9608.500	39.66	-34.30	37.60	36.36	74.00	34.34	V
7968.500	37.81	-35.40	36.80	36.41	74.00	36.19	V
3755.500	34.48	-37.70	32.30	39.88	74.00	39.52	V

GFSK Ch 78

Frequency (MHz)	Measurement Result (dBuV/m)	Cable Loss (dB)	Antenna Factor (dB/m)	Receiver Reading (dBuV)	Limit (dBuV/m)	Margin (dB)	Antenna Pol. (H/V)
17889.500	48.88	-29.40	46.00	32.28	74.00	25.12	V
13920.000	44.50	-30.60	41.40	33.70	74.00	29.50	V
12812.000	41.72	-31.50	39.80	33.42	74.00	32.28	V
9608.500	39.94	-34.30	37.60	36.64	74.00	34.06	V
7792.000	37.67	-35.60	36.50	36.77	74.00	36.33	V
2490.000	54.09	-19.70	28.20	45.59	74.00	19.91	V

$\pi/4$ DQPSK Ch 0

Frequency (MHz)	Measurement Result (dBuV/m)	Cable Loss (dB)	Antenna Factor (dB/m)	Receiver Reading (dBuV)	Limit (dBuV/m)	Margin (dB)	Antenna Pol. (H/V)
17946.000	49.38	-29.40	46.00	32.78	74.00	24.62	V
14680.000	44.74	-30.00	41.50	33.24	74.00	29.26	H
12998.000	41.60	-31.90	40.10	33.40	74.00	32.40	V
9331.500	40.59	-34.10	37.80	36.89	74.00	33.41	V
7931.000	39.02	-35.40	36.80	37.62	74.00	34.98	H
2380.600	55.63	-19.80	28.20	47.23	74.00	18.37	V

 $\pi/4$ DQPSK Ch 39

Frequency (MHz)	Measurement Result (dBuV/m)	Cable Loss (dB)	Antenna Factor (dB/m)	Receiver Reading (dBuV)	Limit (dBuV/m)	Margin (dB)	Antenna Pol. (H/V)
17877.500	49.85	-29.40	46.00	33.25	74.00	24.15	V
14668.500	45.10	-30.00	41.50	33.60	74.00	28.90	V
12421.500	41.01	-31.90	38.90	34.01	74.00	32.99	V
9199.500	40.65	-34.70	37.70	37.65	74.00	33.35	V
7903.000	37.60	-35.20	36.70	36.10	74.00	36.40	V
4947.000	34.52	-37.60	33.30	38.82	74.00	39.48	V

 $\pi/4$ DQPSK Ch 78

Frequency (MHz)	Measurement Result (dBuV/m)	Cable Loss (dB)	Antenna Factor (dB/m)	Receiver Reading (dBuV)	Limit (dBuV/m)	Margin (dB)	Antenna Pol. (H/V)
17984.500	49.84	-29.40	46.00	33.24	74.00	24.16	V
14667.000	44.99	-30.00	41.50	33.49	74.00	29.01	V
12524.000	41.69	-32.10	39.10	34.69	74.00	32.31	V
9607.500	40.21	-34.30	37.60	36.91	74.00	33.79	V
7418.500	37.98	-35.10	36.60	36.48	74.00	36.02	V
2493.600	56.52	-19.70	28.20	48.02	74.00	17.48	V

8DPSK Ch 0

Frequency (MHz)	Measurement Result (dBuV/m)	Cable Loss (dB)	Antenna Factor (dB/m)	Receiver Reading (dBuV)	Limit (dBuV/m)	Margin (dB)	Antenna Pol. (H/V)
17922.000	49.16	-29.40	46.00	32.56	74.00	24.84	V
14723.500	44.77	-30.20	41.40	33.67	74.00	29.23	V
12917.500	41.51	-31.50	40.00	33.01	74.00	32.49	V
9608.000	40.37	-34.30	37.60	37.07	74.00	33.63	V
7991.000	37.76	-35.40	36.90	36.26	74.00	36.24	V
2385.700	58.41	-19.80	28.20	50.01	74.00	15.59	V

8DPSK Ch 39

Frequency (MHz)	Measurement Result (dBuV/m)	Cable Loss (dB)	Antenna Factor (dB/m)	Receiver Reading (dBuV)	Limit (dBuV/m)	Margin (dB)	Antenna Pol. (H/V)
17853.000	49.85	-29.40	46.00	33.25	74.00	24.15	V
14704.000	45.60	-30.20	41.40	34.50	74.00	28.40	H
12102.500	42.76	-32.60	38.90	36.46	74.00	31.24	H
8552.000	40.59	-34.30	37.40	37.49	74.00	33.41	H
7669.500	39.55	-35.50	36.30	38.75	74.00	34.45	H
4952.000	36.45	-37.40	33.60	40.25	74.00	37.55	H

8DPSK Ch 78

Frequency (MHz)	Measurement Result (dBuV/m)	Cable Loss (dB)	Antenna Factor (dB/m)	Receiver Reading (dBuV)	Limit (dBuV/m)	Margin (dB)	Antenna Pol. (H/V)
17926.500	50.10	-29.40	46.00	33.50	74.00	23.90	H
14391.000	45.98	-30.30	41.90	34.38	74.00	28.02	H
12986.000	42.41	-31.90	40.10	34.21	74.00	31.59	H
9484.000	41.37	-34.60	37.70	38.27	74.00	32.63	V
7948.000	38.52	-35.40	36.80	37.12	74.00	35.48	H
2499.700	54.66	-19.70	28.20	46.16	74.00	19.34	V

Average Measurement results
GFSK Ch 0

Frequency (MHz)	Measurement Result (dBuV/m)	Cable Loss (dB)	Antenna Factor (dB/m)	Receiver Reading (dBuV)	Limit (dBuV/m)	Margin (dB)	Antenna Pol. (H/V)
17891.000	40.67	-29.40	46.00	24.07	54.00	13.33	H
14697.500	36.67	-30.00	41.50	25.17	54.00	17.33	V
11933.000	32.52	-32.40	39.00	25.92	54.00	21.48	H
9608.500	32.21	-34.30	37.60	28.91	54.00	21.79	V
7339.000	29.55	-35.90	36.60	28.85	54.00	24.45	H
2337.600	42.40	-19.60	28.20	33.80	54.00	11.60	H

GFSK Ch 39

Frequency (MHz)	Measurement Result (dBuV/m)	Cable Loss (dB)	Antenna Factor (dB/m)	Receiver Reading (dBuV)	Limit (dBuV/m)	Margin (dB)	Antenna Pol. (H/V)
17903.000	40.50	-29.40	46.00	23.90	54.00	13.50	V
14679.500	35.68	-30.00	41.50	24.18	54.00	18.32	V
9607.500	33.53	-34.30	37.60	30.23	54.00	20.47	V
12916.500	32.62	-31.50	40.00	24.12	54.00	21.38	V
7944.000	28.81	-35.40	36.80	27.41	54.00	25.19	V
3811.000	25.51	-38.00	32.50	31.01	54.00	28.49	H

GFSK Ch 78

Frequency (MHz)	Measurement Result (dBuV/m)	Cable Loss (dB)	Antenna Factor (dB/m)	Receiver Reading (dBuV)	Limit (dBuV/m)	Margin (dB)	Antenna Pol. (H/V)
17884.000	40.45	-29.40	46.00	23.85	54.00	13.55	V
14694.500	35.75	-30.00	41.50	24.25	54.00	18.25	V
9608.500	33.35	-34.30	37.60	30.05	54.00	20.65	V
12907.000	32.98	-31.50	40.00	24.48	54.00	21.02	V
7930.500	28.53	-35.40	36.80	27.13	54.00	25.47	V
2499.400	42.37	-19.70	28.20	33.87	54.00	11.63	H

$\pi/4$ DQPSK Ch 0

Frequency (MHz)	Measurement Result (dBuV/m)	Cable Loss (dB)	Antenna Factor (dB/m)	Receiver Reading (dBuV)	Limit (dBuV/m)	Margin (dB)	Antenna Pol. (H/V)
17895.000	40.49	-29.40	46.00	23.89	54.00	13.51	V
14197.000	35.94	-30.20	41.70	24.44	54.00	18.06	V
12832.500	33.17	-31.90	39.90	25.17	54.00	20.83	V
9607.500	32.20	-34.30	37.60	28.90	54.00	21.80	V
7953.000	29.10	-35.40	36.80	27.70	54.00	24.90	V
2349.300	42.45	-19.60	28.20	33.85	54.00	11.55	H

 $\pi/4$ DQPSK Ch 39

Frequency (MHz)	Measurement Result (dBuV/m)	Cable Loss (dB)	Antenna Factor (dB/m)	Receiver Reading (dBuV)	Limit (dBuV/m)	Margin (dB)	Antenna Pol. (H/V)
17884.500	40.45	-29.40	46.00	23.85	54.00	13.55	V
14663.500	36.00	-30.00	41.50	24.50	54.00	18.00	V
9608.000	34.00	-34.30	37.60	30.70	54.00	20.00	V
12353.000	33.03	-32.30	39.00	26.43	54.00	20.97	V
7707.500	29.22	-35.90	36.30	28.82	54.00	24.78	V
4932.000	26.09	-37.60	33.30	30.39	54.00	27.91	V

 $\pi/4$ DQPSK Ch 78

Frequency (MHz)	Measurement Result (dBuV/m)	Cable Loss (dB)	Antenna Factor (dB/m)	Receiver Reading (dBuV)	Limit (dBuV/m)	Margin (dB)	Antenna Pol. (H/V)
17880.500	40.91	-29.40	46.00	24.31	54.00	13.09	V
14677.500	37.26	-30.00	41.50	25.76	54.00	16.74	V
12376.000	32.78	-32.30	39.00	26.18	54.00	21.22	V
9608.500	31.88	-34.30	37.60	28.58	54.00	22.12	V
7963.500	29.15	-35.40	36.80	27.75	54.00	24.85	H
2485.900	42.98	-19.70	28.20	34.48	54.00	11.02	V

8DPSK Ch 0

Frequency (MHz)	Measurement Result (dBuV/m)	Cable Loss (dB)	Antenna Factor (dB/m)	Receiver Reading (dBuV)	Limit (dBuV/m)	Margin (dB)	Antenna Pol. (H/V)
17867.000	40.38	-29.40	46.00	23.78	54.00	13.62	H
14713.000	36.42	-30.20	41.40	25.32	54.00	17.58	V
12365.000	32.98	-32.30	39.00	26.38	54.00	21.02	H
9607.500	32.14	-34.30	37.60	28.84	54.00	21.86	V
7524.500	29.18	-35.10	36.40	27.88	54.00	24.82	H
2341.100	42.39	-19.60	28.20	33.79	54.00	11.61	V

8DPSK Ch 39

Frequency (MHz)	Measurement Result (dBuV/m)	Cable Loss (dB)	Antenna Factor (dB/m)	Receiver Reading (dBuV)	Limit (dBuV/m)	Margin (dB)	Antenna Pol. (H/V)
17889.000	40.71	-29.40	46.00	24.11	54.00	13.29	V
14189.000	37.24	-30.20	41.70	25.74	54.00	16.76	H
11882.000	33.82	-32.40	39.10	27.12	54.00	20.18	H
9502.000	32.37	-34.60	37.70	29.27	54.00	21.63	H
7207.000	30.43	-35.40	36.20	29.63	54.00	23.57	H
4948.500	27.51	-37.60	33.30	31.81	54.00	26.49	H

8DPSK Ch 78

Frequency (MHz)	Measurement Result (dBuV/m)	Cable Loss (dB)	Antenna Factor (dB/m)	Receiver Reading (dBuV)	Limit (dBuV/m)	Margin (dB)	Antenna Pol. (H/V)
17890.000	40.85	-29.40	46.00	24.25	54.00	13.15	V
14668.000	36.34	-30.00	41.50	24.84	54.00	17.66	V
12916.000	33.20	-31.50	40.00	24.70	54.00	20.80	H
9608.500	31.88	-34.30	37.60	28.58	54.00	22.12	V
7956.500	30.00	-35.40	36.80	28.60	54.00	24.00	V
2485.000	42.70	-19.70	28.20	34.20	54.00	11.30	V

Note: the spurious emission above 18G is noise only. No emissions were found within 20dB of the limit below 1GHz.

Radiated Spurious Emission- above 1GHz
EUT ID: EUT2

Peak Measurement results
GFSK Ch 0

Frequency (MHz)	Measurement Result (dBuV/m)	Cable Loss (dB)	Antenna Factor (dB/m)	Receiver Reading (dBuV)	Limit (dBuV/m)	Margin (dB)	Antenna Pol. (H/V)
17997.000	50.73	-29.40	46.00	34.13	74.00	23.27	H
14203.000	46.29	-30.20	41.70	34.79	74.00	27.71	V
12900.500	43.45	-31.50	40.00	34.95	74.00	30.55	H
9960.500	41.39	-34.10	38.00	37.59	74.00	32.61	H
7926.500	39.82	-35.40	36.80	38.42	74.00	34.18	V
2386.900	51.69	-19.80	28.20	43.29	74.00	22.31	H

GFSK Ch 39

Frequency (MHz)	Measurement Result (dBuV/m)	Cable Loss (dB)	Antenna Factor (dB/m)	Receiver Reading (dBuV)	Limit (dBuV/m)	Margin (dB)	Antenna Pol. (H/V)
17849.500	49.10	-29.40	46.00	32.50	74.00	24.90	V
14056.000	45.49	-31.10	41.60	34.99	74.00	28.51	H
12997.000	42.07	-31.90	40.10	33.87	74.00	31.93	V
9763.500	41.26	-33.80	38.00	37.06	74.00	32.74	V
7424.500	37.98	-35.10	36.60	36.48	74.00	36.02	H
4758.500	36.16	-37.50	33.10	40.56	74.00	37.84	V

GFSK Ch 78

Frequency (MHz)	Measurement Result (dBuV/m)	Cable Loss (dB)	Antenna Factor (dB/m)	Receiver Reading (dBuV)	Limit (dBuV/m)	Margin (dB)	Antenna Pol. (H/V)
17914.000	48.94	-29.40	46.00	32.34	74.00	25.06	H
14701.000	45.14	-30.00	41.50	33.64	74.00	28.86	H
12370.000	42.10	-32.30	39.00	35.50	74.00	31.90	V
8702.000	39.46	-34.40	37.70	36.16	74.00	34.54	V
7895.000	38.22	-35.20	36.70	36.72	74.00	35.78	H
2490.100	51.92	-19.70	28.20	43.42	74.00	22.08	H

$\pi/4$ DQPSK Ch 0

Frequency (MHz)	Measurement Result (dBuV/m)	Cable Loss (dB)	Antenna Factor (dB/m)	Receiver Reading (dBuV)	Limit (dBuV/m)	Margin (dB)	Antenna Pol. (H/V)
17913.000	50.67	-29.40	46.00	34.07	74.00	23.33	V
14720.000	46.22	-30.20	41.40	35.12	74.00	27.78	H
10594.500	43.25	-33.50	38.30	38.45	74.00	30.75	H
9349.000	40.82	-34.10	37.80	37.12	74.00	33.18	H
7975.500	39.76	-35.40	36.90	38.26	74.00	34.24	H
2362.800	51.67	-19.60	28.20	43.07	74.00	22.33	V

 $\pi/4$ DQPSK Ch 39

Frequency (MHz)	Measurement Result (dBuV/m)	Cable Loss (dB)	Antenna Factor (dB/m)	Receiver Reading (dBuV)	Limit (dBuV/m)	Margin (dB)	Antenna Pol. (H/V)
17874.500	48.80	-29.40	46.00	32.20	74.00	25.20	H
14556.000	44.77	-29.00	41.90	31.87	74.00	29.23	V
12013.500	41.35	-32.70	39.00	35.05	74.00	32.65	H
9189.000	39.10	-34.70	37.70	36.10	74.00	34.90	V
7925.500	37.97	-35.40	36.80	36.57	74.00	36.03	V
4078.000	37.76	-38.00	32.20	43.56	74.00	36.24	H

 $\pi/4$ DQPSK Ch 78

Frequency (MHz)	Measurement Result (dBuV/m)	Cable Loss (dB)	Antenna Factor (dB/m)	Receiver Reading (dBuV)	Limit (dBuV/m)	Margin (dB)	Antenna Pol. (H/V)
17871.000	48.86	-29.40	46.00	32.26	74.00	25.14	H
14668.500	44.54	-30.00	41.50	33.04	74.00	29.46	V
12850.000	42.14	-31.90	39.90	34.14	74.00	31.86	H
9483.500	40.32	-34.60	37.70	37.22	74.00	33.68	V
7388.500	38.55	-35.10	36.60	37.05	74.00	35.45	V
2491.400	51.39	-19.70	28.20	42.89	74.00	22.61	V

8DPSK Ch 0

Frequency (MHz)	Measurement Result (dBuV/m)	Cable Loss (dB)	Antenna Factor (dB/m)	Receiver Reading (dBuV)	Limit (dBuV/m)	Margin (dB)	Antenna Pol. (H/V)
17912.000	50.31	-29.40	46.00	33.71	74.00	23.69	H
14686.500	46.37	-30.00	41.50	34.87	74.00	27.63	H
12914.000	43.11	-31.50	40.00	34.61	74.00	30.89	V
9506.000	41.27	-33.80	37.60	37.47	74.00	32.73	V
7963.500	38.89	-35.40	36.80	37.49	74.00	35.11	H
2343.900	52.27	-19.60	28.20	43.67	74.00	21.73	V

8DPSK Ch 39

Frequency (MHz)	Measurement Result (dBuV/m)	Cable Loss (dB)	Antenna Factor (dB/m)	Receiver Reading (dBuV)	Limit (dBuV/m)	Margin (dB)	Antenna Pol. (H/V)
17891.500	49.71	-29.40	46.00	33.11	74.00	24.29	V
14200.000	44.76	-30.20	41.70	33.26	74.00	29.24	V
12893.000	41.68	-31.50	40.00	33.18	74.00	32.32	H
9479.500	39.76	-34.60	37.70	36.66	74.00	34.24	H
5995.000	38.79	-36.80	34.50	41.09	74.00	35.21	V
4772.000	36.26	-37.50	33.10	40.66	74.00	37.74	V

8DPSK Ch 78

Frequency (MHz)	Measurement Result (dBuV/m)	Cable Loss (dB)	Antenna Factor (dB/m)	Receiver Reading (dBuV)	Limit (dBuV/m)	Margin (dB)	Antenna Pol. (H/V)
17874.000	49.22	-29.40	46.00	32.62	74.00	24.78	H
14206.500	45.88	-30.20	41.70	34.38	74.00	28.12	H
12593.500	42.14	-32.20	39.30	35.04	74.00	31.86	H
8720.500	40.11	-34.80	37.90	37.01	74.00	33.89	V
7460.000	38.23	-35.50	36.50	37.23	74.00	35.77	V
2492.800	51.80	-19.70	28.20	43.30	74.00	22.20	H

Average Measurement results
GFSK Ch 0

Frequency (MHz)	Measurement Result (dBuV/m)	Cable Loss (dB)	Antenna Factor (dB/m)	Receiver Reading (dBuV)	Limit (dBuV/m)	Margin (dB)	Antenna Pol. (H/V)
17869.500	41.52	-29.40	46.00	24.92	54.00	12.48	H
14688.000	37.55	-30.00	41.50	26.05	54.00	16.45	H
11889.000	34.66	-32.40	39.10	27.96	54.00	19.34	H
9012.500	32.19	-34.30	37.80	28.69	54.00	21.81	H
7946.000	30.58	-35.40	36.80	29.18	54.00	23.42	V
2346.800	39.92	-19.60	28.20	31.32	54.00	14.08	H

GFSK Ch 39

Frequency (MHz)	Measurement Result (dBuV/m)	Cable Loss (dB)	Antenna Factor (dB/m)	Receiver Reading (dBuV)	Limit (dBuV/m)	Margin (dB)	Antenna Pol. (H/V)
17982.500	40.06	-29.40	46.00	23.46	54.00	13.94	V
14698.000	36.19	-30.00	41.50	24.69	54.00	17.81	H
9763.500	33.66	-33.80	38.00	29.46	54.00	20.34	V
11895.000	32.52	-32.40	39.10	25.82	54.00	21.48	H
7541.000	29.46	-35.50	36.30	28.66	54.00	24.54	H
4936.500	27.59	-37.60	33.30	31.89	54.00	26.41	H

GFSK Ch 78

Frequency (MHz)	Measurement Result (dBuV/m)	Cable Loss (dB)	Antenna Factor (dB/m)	Receiver Reading (dBuV)	Limit (dBuV/m)	Margin (dB)	Antenna Pol. (H/V)
17994.000	40.13	-29.40	46.00	23.53	54.00	13.87	H
14702.000	35.80	-30.00	41.50	24.30	54.00	18.20	H
12991.000	32.64	-31.90	40.10	24.44	54.00	21.36	V
9920.500	31.08	-33.80	37.90	26.98	54.00	22.92	V
7524.500	29.27	-35.10	36.40	27.97	54.00	24.73	V
2489.700	40.31	-19.70	28.20	31.81	54.00	13.69	H

$\pi/4$ DQPSK Ch 0

Frequency (MHz)	Measurement Result (dBuV/m)	Cable Loss (dB)	Antenna Factor (dB/m)	Receiver Reading (dBuV)	Limit (dBuV/m)	Margin (dB)	Antenna Pol. (H/V)
17877.500	42.15	-29.40	46.00	25.55	54.00	11.85	V
14696.500	37.44	-30.00	41.50	25.94	54.00	16.56	V
12368.500	34.14	-32.30	39.00	27.54	54.00	19.86	H
9607.500	32.92	-34.30	37.60	29.62	54.00	21.08	V
7525.000	30.15	-35.50	36.30	29.35	54.00	23.85	H
2355.700	39.62	-19.60	28.20	31.02	54.00	14.38	V

 $\pi/4$ DQPSK Ch 39

Frequency (MHz)	Measurement Result (dBuV/m)	Cable Loss (dB)	Antenna Factor (dB/m)	Receiver Reading (dBuV)	Limit (dBuV/m)	Margin (dB)	Antenna Pol. (H/V)
17986.000	39.91	-29.40	46.00	23.31	54.00	14.09	V
14688.500	35.94	-30.00	41.50	24.44	54.00	18.06	V
12949.000	32.27	-31.40	40.00	23.67	54.00	21.73	V
9478.000	30.33	-34.60	37.70	27.23	54.00	23.67	V
7994.000	28.98	-35.40	36.90	27.48	54.00	25.02	H
3138.000	26.35	-38.00	31.00	33.35	54.00	27.65	H

 $\pi/4$ DQPSK Ch 78

Frequency (MHz)	Measurement Result (dBuV/m)	Cable Loss (dB)	Antenna Factor (dB/m)	Receiver Reading (dBuV)	Limit (dBuV/m)	Margin (dB)	Antenna Pol. (H/V)
17903.500	40.38	-29.40	46.00	23.78	54.00	13.62	V
14697.500	36.06	-30.00	41.50	24.56	54.00	17.94	V
12356.500	33.12	-32.30	39.00	26.52	54.00	20.88	H
8768.500	30.59	-34.20	37.90	26.89	54.00	23.41	V
7994.000	29.77	-35.40	36.90	28.27	54.00	24.23	H
2488.000	40.21	-19.70	28.20	31.71	54.00	13.79	V

8DPSK Ch 0

Frequency (MHz)	Measurement Result (dBuV/m)	Cable Loss (dB)	Antenna Factor (dB/m)	Receiver Reading (dBuV)	Limit (dBuV/m)	Margin (dB)	Antenna Pol. (H/V)
17912.500	41.90	-29.40	46.00	25.30	54.00	12.10	H
14666.000	37.68	-30.00	41.50	26.18	54.00	16.32	V
11900.000	34.10	-32.40	39.10	27.40	54.00	19.90	V
9608.500	32.82	-34.30	37.60	29.52	54.00	21.18	V
7962.500	30.57	-35.40	36.80	29.17	54.00	23.43	V
2341.900	39.91	-19.60	28.20	31.31	54.00	14.09	V

8DPSK Ch 39

Frequency (MHz)	Measurement Result (dBuV/m)	Cable Loss (dB)	Antenna Factor (dB/m)	Receiver Reading (dBuV)	Limit (dBuV/m)	Margin (dB)	Antenna Pol. (H/V)
17999.000	40.33	-29.40	46.00	23.73	54.00	13.67	H
14695.000	35.77	-30.00	41.50	24.27	54.00	18.23	H
12997.500	33.03	-31.90	40.10	24.83	54.00	20.97	V
8729.500	30.73	-34.80	37.90	27.63	54.00	23.27	V
7938.000	28.84	-35.40	36.80	27.44	54.00	25.16	V
3138.000	27.36	-38.00	31.00	34.36	54.00	26.64	H

8DPSK Ch 78

Frequency (MHz)	Measurement Result (dBuV/m)	Cable Loss (dB)	Antenna Factor (dB/m)	Receiver Reading (dBuV)	Limit (dBuV/m)	Margin (dB)	Antenna Pol. (H/V)
17894.500	40.50	-29.40	46.00	23.90	54.00	13.50	V
14675.500	35.99	-30.00	41.50	24.49	54.00	18.01	H
11903.000	33.29	-32.40	39.10	26.59	54.00	20.71	V
8736.500	31.17	-34.80	37.90	28.07	54.00	22.83	V
7799.000	29.42	-35.60	36.50	28.52	54.00	24.58	H
2487.600	40.68	-19.70	28.20	32.18	54.00	13.32	V

Note: the spurious emission above 18G is noise only. No emissions were found within 20dB of the limit below 1GHz.

Conclusion: Pass

Band Edges Compliance– Radiated
EUT ID: EUT1

Mode	Channel	Frequency Range	Test Results	Conclusion
GFSK	0	2.31GHz ~2.45GHz	Fig.1	P
	78	2.45GHz ~2.5GHz	Fig.2	P

Mode	Channel	Frequency Range	Test Results	Conclusion
$\pi/4$ DQPSK	0	2.31GHz ~2.43GHz	Fig.3	P
	78	2.45GHz ~2.5GHz	Fig.4	P

Mode	Channel	Frequency Range	Test Results	Conclusion
8DPSK	0	2.31GHz ~2.45GHz	Fig.5	P
	78	2.45GHz ~2.5GHz	Fig.6	P

EUT ID: EUT2

Mode	Channel	Frequency Range	Test Results	Conclusion
GFSK	0	2.31GHz ~2.45GHz	Fig.7	P
	78	2.45GHz ~2.5GHz	Fig.8	P

Mode	Channel	Frequency Range	Test Results	Conclusion
$\pi/4$ DQPSK	0	2.31GHz ~2.43GHz	Fig.9	P
	78	2.45GHz ~2.5GHz	Fig.10	P

Mode	Channel	Frequency Range	Test Results	Conclusion
8DPSK	0	2.31GHz ~2.45GHz	Fig.11	P
	78	2.45GHz ~2.5GHz	Fig.12	P

Conclusion: PASS

Test graphs as below

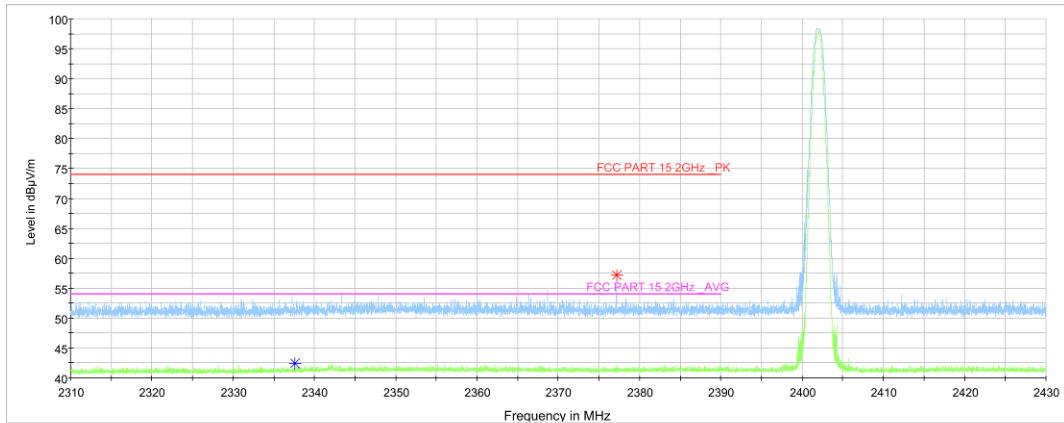

Fig.1. Frequency Band Edges: GFSK, Channel 0, Hopping Off, 2.31 GHz – 2.45GHz

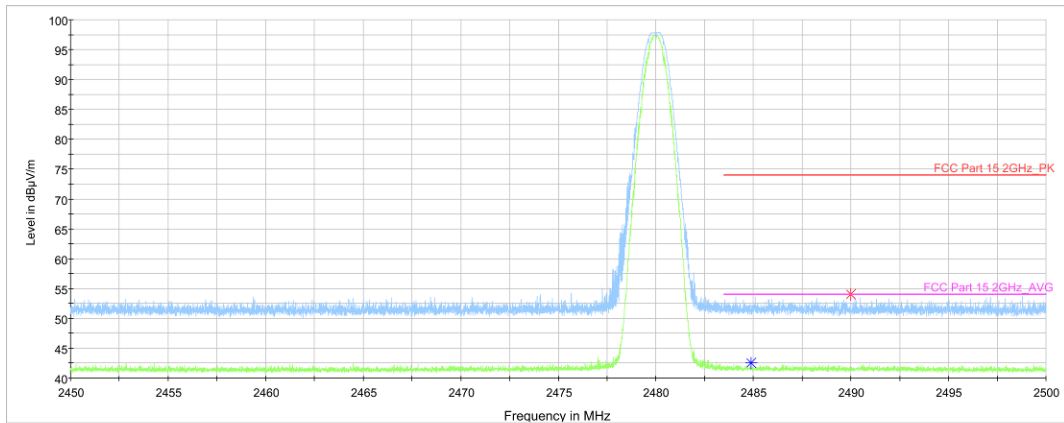

Fig.2. Frequency Band Edges: GFSK, Channel 78, Hopping Off, ch11, 2.45 GHz - 2.50GHz

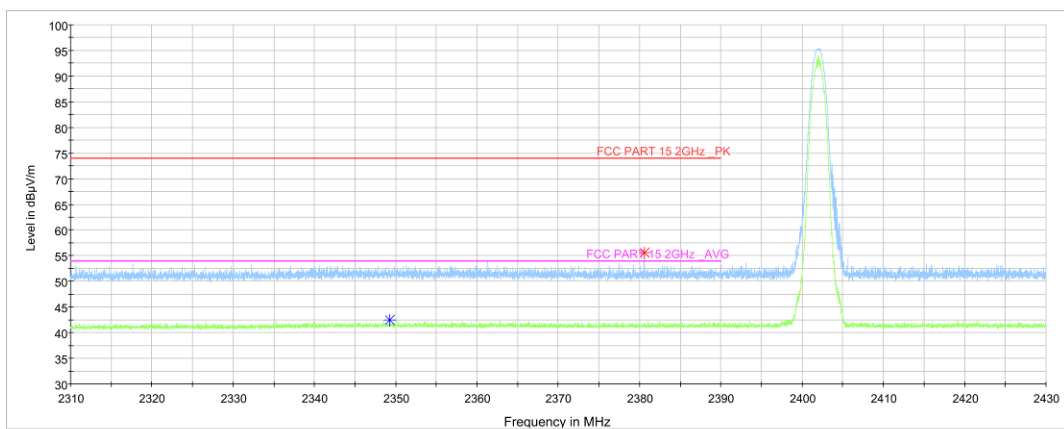

Fig.3. Frequency Band Edges: $\pi/4$ DQPSK, Channel 0, Hopping Off, 2.31 GHz - 2.45GHz

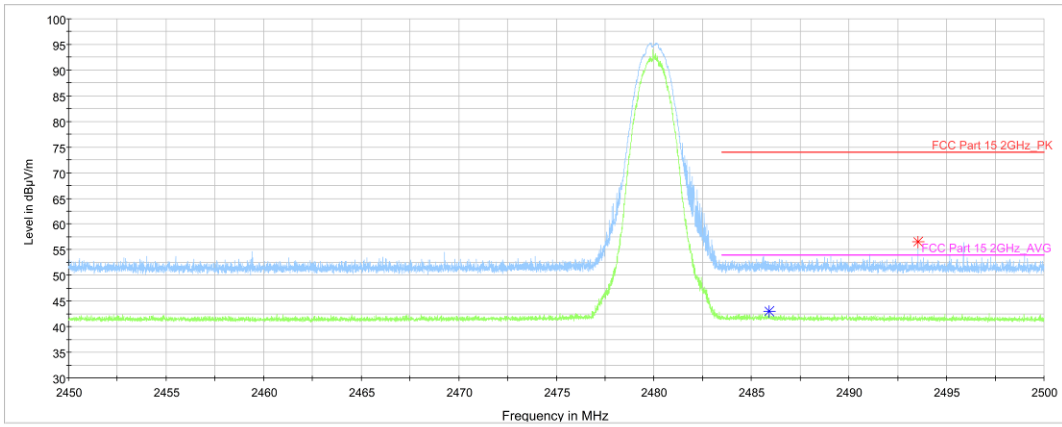

Fig.4. Frequency Band Edges: $\pi/4$ DQPSK, Channel 78, Hopping Off, 2.45 GHz - 2.50GHz

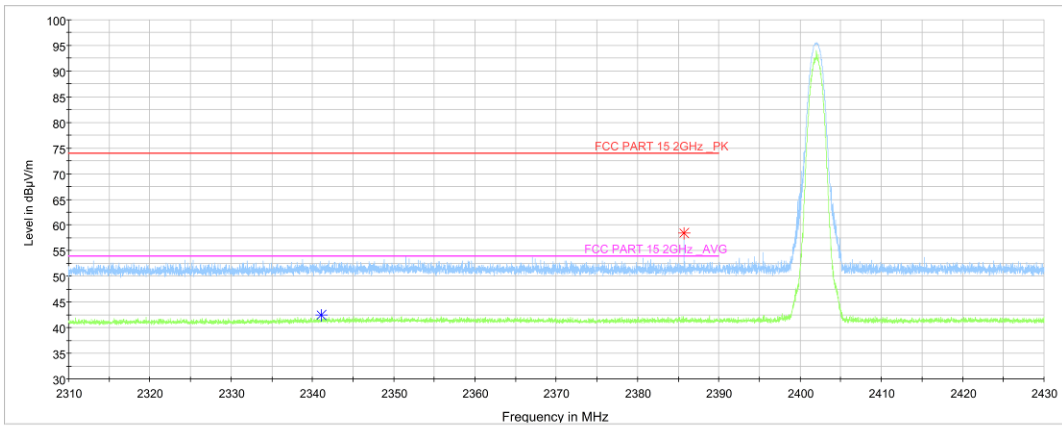

Fig.5. Frequency Band Edges: 8DPSK, Channel 0, 2.31 GHz - 2.45GHz

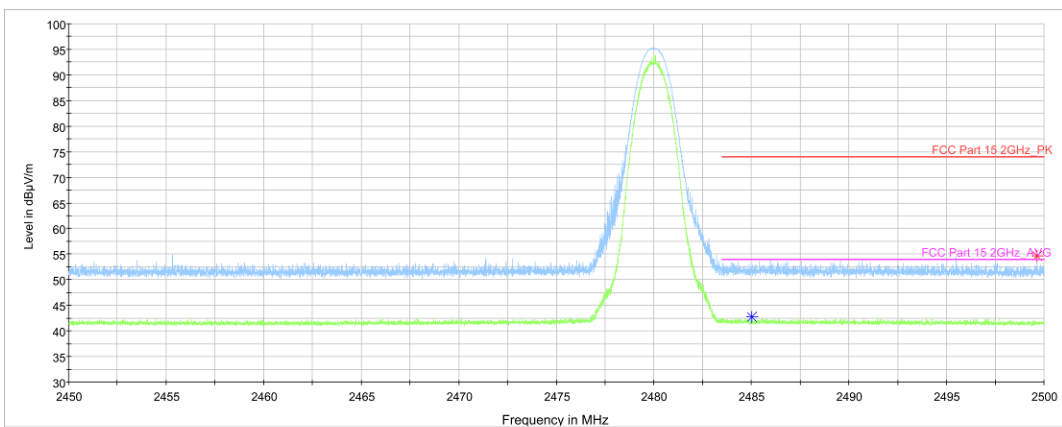

Fig.6. Frequency Band Edges: 8DPSK, Channel 78, 2.45 GHz - 2.50GHz

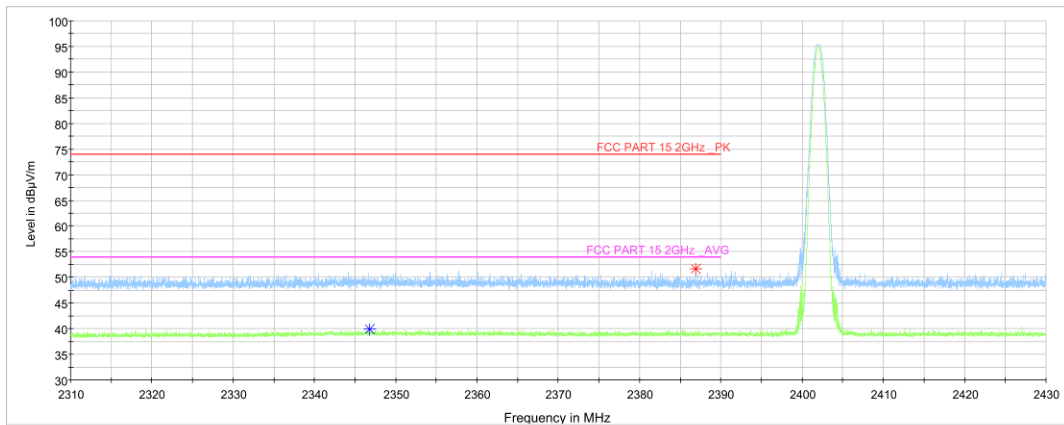

Fig.7. Frequency Band Edges: GFSK, Channel 0, Hopping Off, 2.31 GHz – 2.45GHz

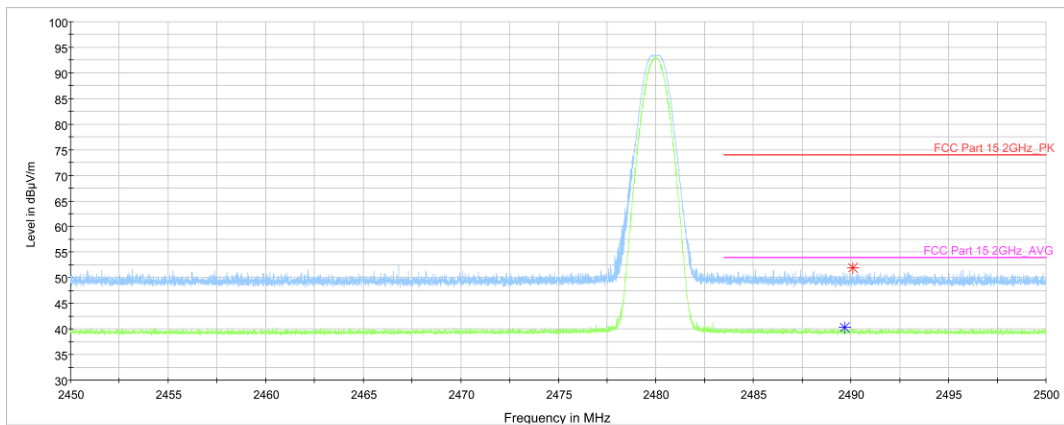

Fig.8. Frequency Band Edges: GFSK, Channel 78, Hopping Off, ch11, 2.45 GHz - 2.50GHz

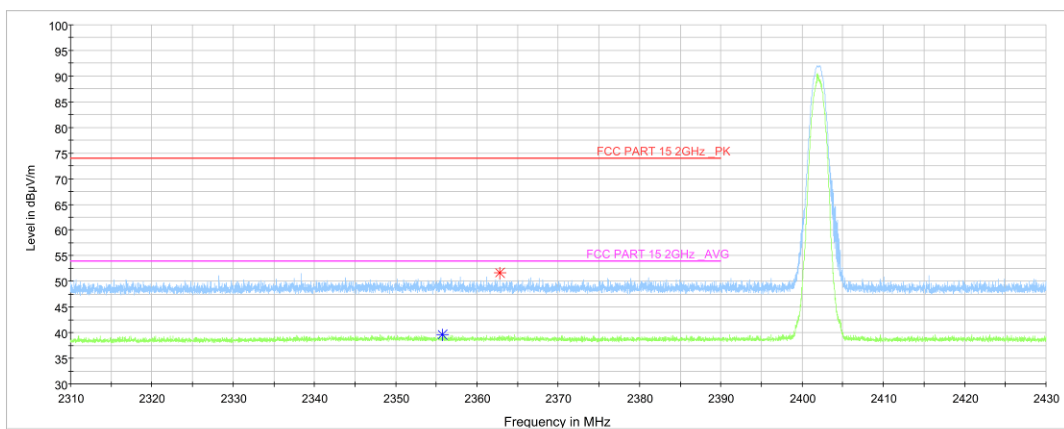

Fig.9. Frequency Band Edges: $\pi/4$ DQPSK, Channel 0, Hopping Off, 2.31 GHz - 2.45GHz

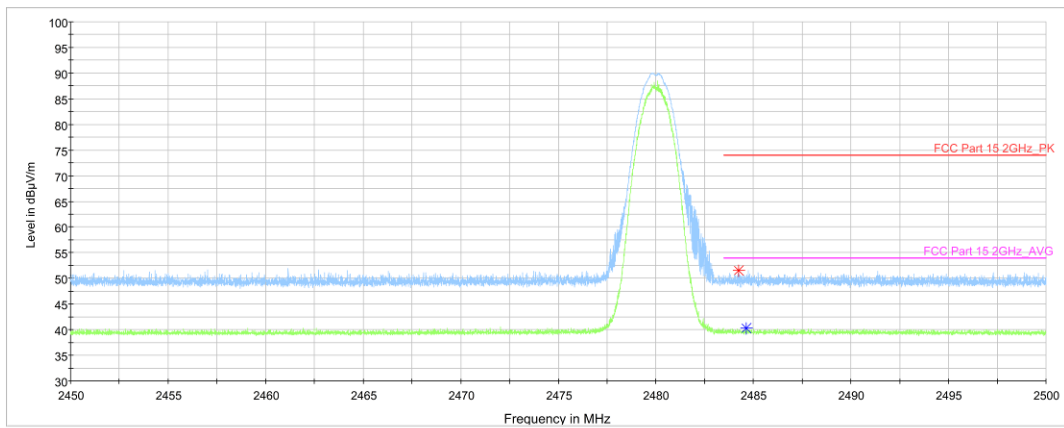

Fig.10. Frequency Band Edges: $\pi/4$ DQPSK, Channel 78, Hopping Off, 2.45 GHz - 2.50GHz

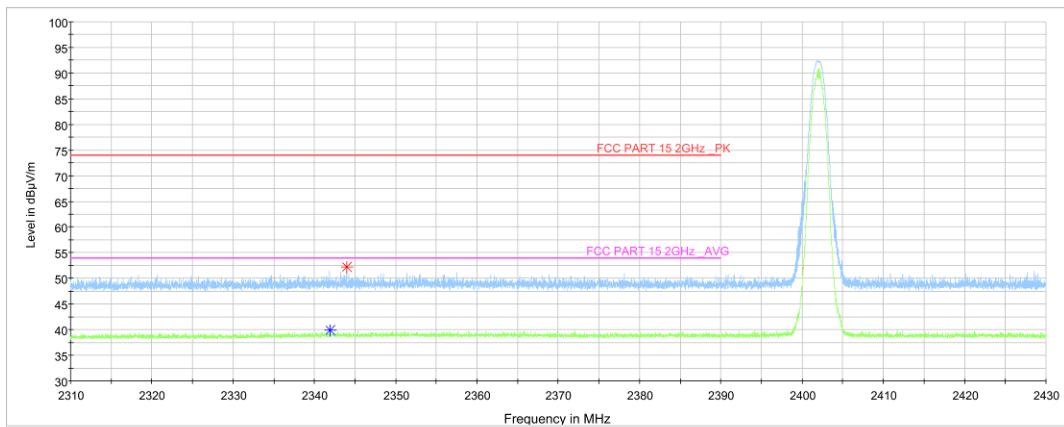

Fig.11. Frequency Band Edges: 8DPSK, Channel 0, 2.31 GHz - 2.45GHz

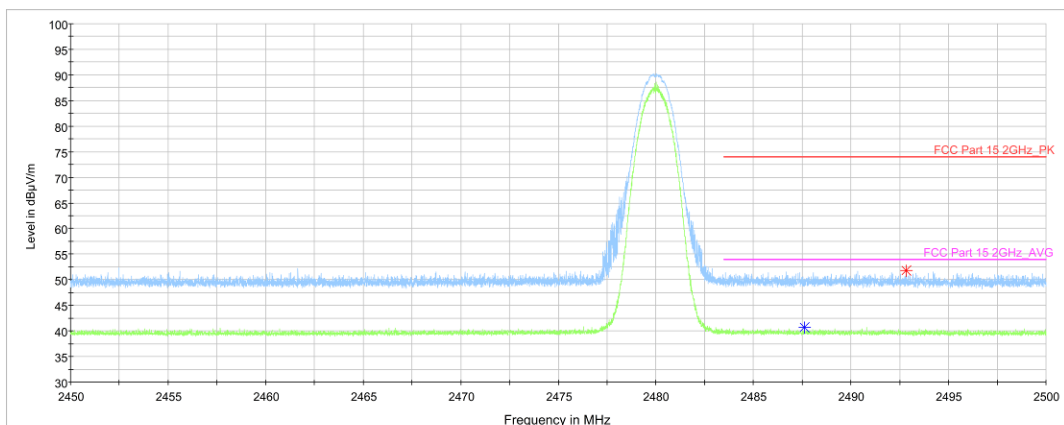

Fig.12. Frequency Band Edges: 8DPSK, Channel 78, 2.45 GHz - 2.50GHz

C.2. AC Powerline Conducted Emission

Specification Reference

FCC 47 CFR Part 15.207, 15.107

Summary

All AC line conducted spurious emissions are measured with a receiver connected to a grounded LISN while the EUT is operating at its maximum duty cycle, at maximum power, and at the appropriate frequencies. All data rates and modes were investigated for conducted spurious emissions. Only the conducted emissions of the configuration that produced the worst case emissions are reported in this section

Method of Measurement

See Clause 6.2 of ANSI C63.10 specifically.

See Clause 4 and Clause 5 of ANSI C63.10 generally.

The conducted emissions from the AC port of the EUT are measured in a shielding room. The EUT is connected to a Line Impedance Stabilization Network (LISN). An overview sweep with peak detection was performed. The measurements were performed with a quasi-peak detector and if required, an average detector.

The conducted emission measurements were made with the following detector of the test receiver: Quasi-Peak / Average Detector.

The measurement bandwidth is:

Frequency of Emission (MHz)	RBW/IF bandwidth
0.15-30	9kHz

Test Condition

Voltage (V)	Frequency (Hz)
120	60

Measurement Setup

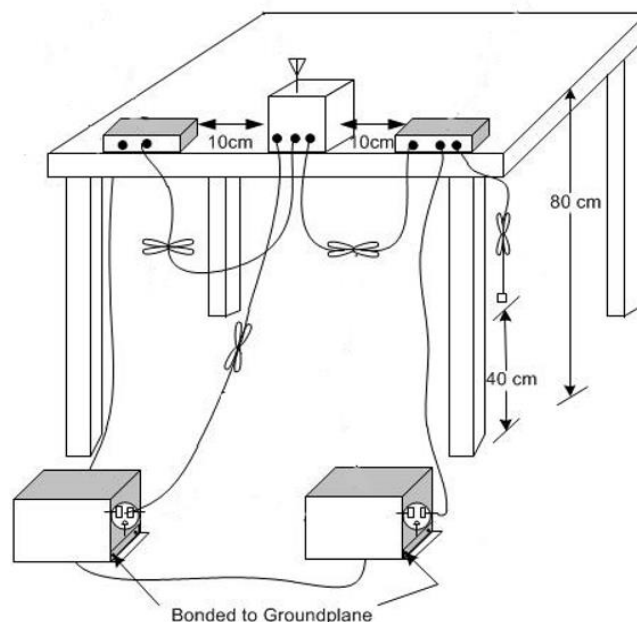

Measurement Result and limit

Bluetooth (Quasi-peak Limit)

Frequency range (MHz)	Quasi-peak Limit (dB μ V)	Result (dB μ V)		Conclusion
		EUT 1 With charger		
		Bluetooth	Idle	
0.15 to 0.5	66 to 56	Fig.C.2.1	Fig.C.2.2	P
0.5 to 5	56			
5 to 30	60			

NOTE: The limit decreases linearly with the logarithm of the frequency in the range 0.15 MHz to 0.5 MHz.

Bluetooth (Average Limit)

Frequency range (MHz)	Average Limit (dB μ V)	Result (dB μ V)		Conclusion
		EUT 1 With charger		
		Bluetooth	Idle	
0.15 to 0.5	56 to 46	Fig.C.2.1	Fig.C.2.2	P
0.5 to 5	46			
5 to 30	50			

NOTE: The limit decreases linearly with the logarithm of the frequency in the range 0.15 MHz to 0.5 MHz.

Bluetooth (Quasi-peak Limit)

Frequency range (MHz)	Quasi-peak Limit (dB μ V)	Result (dB μ V)		Conclusion
		EUT 2 With charger		
		Bluetooth	Idle	
0.15 to 0.5	67 to 56	Fig.C.2.3	Fig.C.2.4	P
0.5 to 5	56			
5 to 30	60			

NOTE: The limit decreases linearly with the logarithm of the frequency in the range 0.15 MHz to 0.5 MHz.

Bluetooth (Average Limit)

Frequency range (MHz)	Average Limit (dB μ V)	Result (dB μ V)		Conclusion
		EUT 2 With charger		
		Bluetooth	Idle	
0.15 to 0.5	56 to 46	Fig.C.2.3	Fig.C.2.4	P
0.5 to 5	46			
5 to 30	50			

NOTE: The limit decreases linearly with the logarithm of the frequency in the range 0.15 MHz to 0.5 MHz.

Note: all modes have been tested and the worst results shown here.

Conclusion: Pass

Test graphs as below:

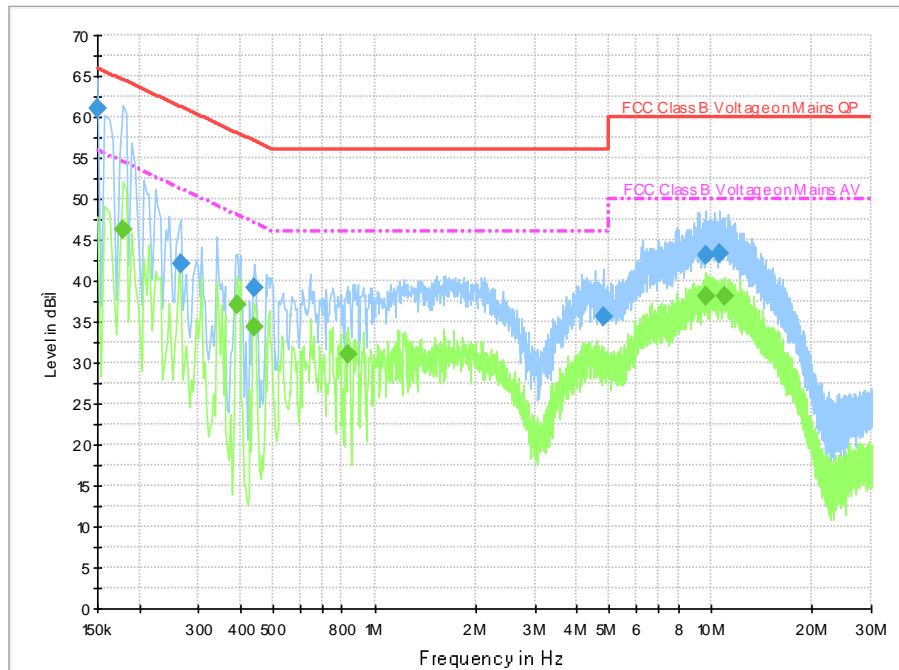

Fig.C.2.1 AC Power line Conducted Emission- Bluetooth

Note: The graphic result above is the maximum of the measurements for both phase line and neutral line.

Final Result 1

Frequency (MHz)	QuasiPeak (dBμV)	Meas. Time	Bandwidth (kHz)	Filter	Line	Corr. (dB)	Margin (dB)	Limit (dBμV)	Comment
0.150000	61.0	2000.0	9.000	On	N	20.0	5.0	66.0	
0.266000	42.2	2000.0	9.000	On	L1	19.7	19.1	61.2	
0.438000	39.1	2000.0	9.000	On	N	19.7	18.0	57.1	
4.774000	35.7	2000.0	9.000	On	N	19.6	20.3	56.0	
9.654000	43.2	2000.0	9.000	On	N	19.6	16.8	60.0	
10.602000	43.4	2000.0	9.000	On	N	19.7	16.6	60.0	

Final Result 2

Frequency (MHz)	CAverage (dBμV)	Meas. Time	Bandwidth (kHz)	Filter	Line	Corr. (dB)	Margin (dB)	Limit (dBμV)	Comment
0.178000	46.3	2000.0	9.000	On	L1	19.7	8.3	54.6	
0.390000	37.2	2000.0	9.000	On	L1	19.7	10.9	48.1	
0.438000	34.4	2000.0	9.000	On	N	19.7	12.7	47.1	
0.830000	31.1	2000.0	9.000	On	N	19.7	14.9	46.0	
9.654000	38.2	2000.0	9.000	On	N	19.6	11.8	50.0	
11.026000	38.2	2000.0	9.000	On	N	19.7	11.8	50.0	

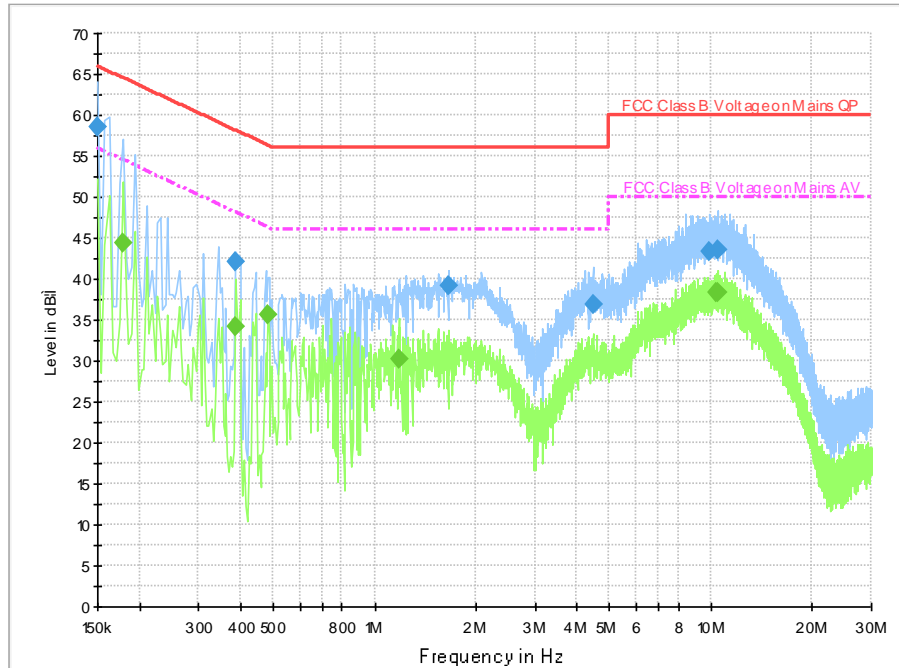

Fig.C.2.2 AC Power line Conducted Emission-Idle

Note: The graphic result above is the maximum of the measurements for both phase line and neutral line.

Final Result 1

Frequency (MHz)	QuasiPeak (dB μ V)	Meas. Time	Bandwidth (kHz)	Filter	Line	Corr. (dB)	Margin (dB)	Limit (dB μ V)	Comment
0.150000	58.5	2000.0	9.000	On	L1	20.0	7.5	66.0	
0.386000	42.1	2000.0	9.000	On	L1	19.7	16.1	58.1	
1.662000	39.1	2000.0	9.000	On	N	19.6	16.9	56.0	
4.454000	36.9	2000.0	9.000	On	N	19.6	19.1	56.0	
9.954000	43.3	2000.0	9.000	On	N	19.7	16.7	60.0	
10.538000	43.5	2000.0	9.000	On	N	19.7	16.5	60.0	

Final Result 2

Frequency (MHz)	CAverage (dB μ V)	Meas. Time	Bandwidth (kHz)	Filter	Line	Corr. (dB)	Margin (dB)	Limit (dB μ V)	Comment
0.178000	44.3	2000.0	9.000	On	L1	19.7	10.3	54.6	
0.386000	34.3	2000.0	9.000	On	L1	19.7	13.9	48.1	
0.482000	35.6	2000.0	9.000	On	L1	19.7	10.7	46.3	
1.178000	30.3	2000.0	9.000	On	N	19.6	15.7	46.0	
10.374000	38.3	2000.0	9.000	On	N	19.7	11.7	50.0	
10.538000	38.3	2000.0	9.000	On	N	19.7	11.7	50.0	

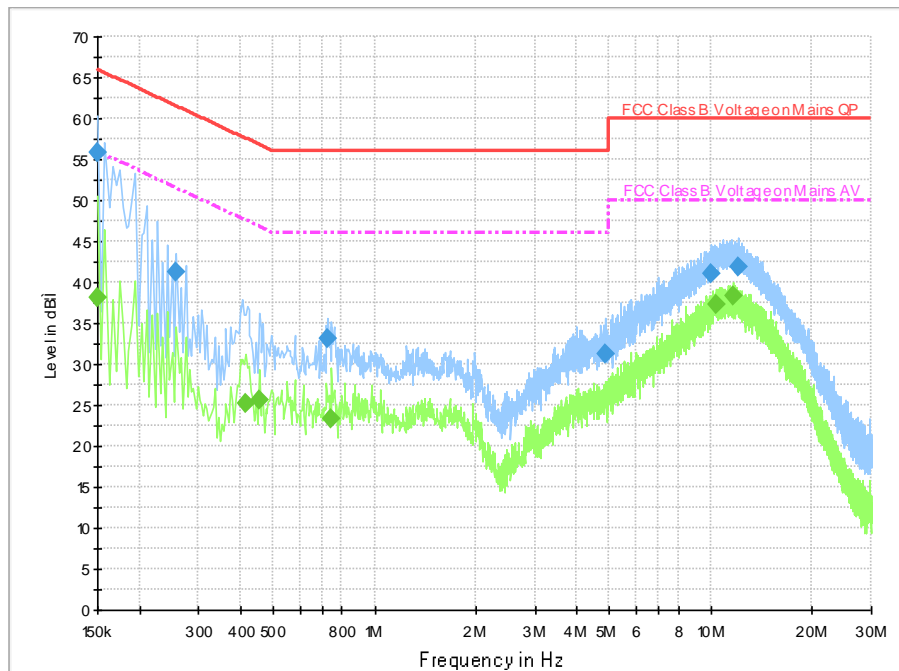

Fig.C.2.3 AC Power line Conducted Emission- Bluetooth

Note: The graphic result above is the maximum of the measurements for both phase line and neutral line.

Final Result 1

Frequency (MHz)	QuasiPeak (dBμV)	Meas. Time	Bandwidth (kHz)	Filter	Line	Corr. (dB)	Margin (dB)	Limit (dBμV)	Comment
0.150000	55.8	2000.0	9.000	On	L1	20.0	10.2	66.0	
0.258000	41.3	2000.0	9.000	On	L1	19.7	20.2	61.5	
0.726000	33.1	2000.0	9.000	On	L1	19.7	22.9	56.0	
4.882000	31.2	2000.0	9.000	On	L1	19.6	24.8	56.0	
10.026000	41.1	2000.0	9.000	On	L1	19.7	18.9	60.0	
12.078000	41.9	2000.0	9.000	On	L1	19.7	18.1	60.0	

Final Result 2

Frequency (MHz)	CAverage (dBμV)	Meas. Time	Bandwidth (kHz)	Filter	Line	Corr. (dB)	Margin (dB)	Limit (dBμV)	Comment
0.150000	38.0	2000.0	9.000	On	L1	20.0	18.0	56.0	
0.414000	25.2	2000.0	9.000	On	L1	19.7	22.4	47.6	
0.454000	25.7	2000.0	9.000	On	L1	19.7	21.1	46.8	
0.746000	23.3	2000.0	9.000	On	L1	19.7	22.7	46.0	
10.322000	37.3	2000.0	9.000	On	L1	19.7	12.7	50.0	
11.638000	38.4	2000.0	9.000	On	L1	19.7	11.6	50.0	

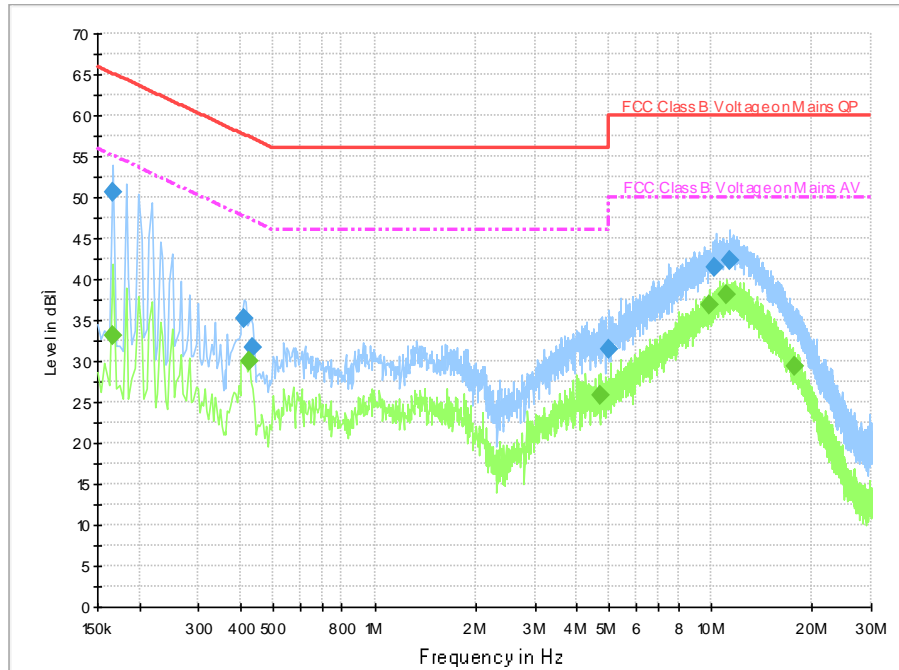

Fig.C.2.4 AC Power line Conducted Emission-Idle

Note: The graphic result above is the maximum of the measurements for both phase line and neutral line.

Final Result 1

Frequency (MHz)	QuasiPeak (dB μ V)	Meas. Time	Bandwidth (kHz)	Filter	Line	Corr. (dB)	Margin (dB)	Limit (dB μ V)	Comment
0.166000	50.7	2000.0	9.000	On	L1	19.8	14.5	65.2	
0.410000	35.2	2000.0	9.000	On	L1	19.7	22.5	57.6	
0.434000	31.7	2000.0	9.000	On	L1	19.7	25.4	57.2	
4.994000	31.4	2000.0	9.000	On	L1	19.6	24.6	56.0	
10.290000	41.6	2000.0	9.000	On	L1	19.7	18.4	60.0	
11.418000	42.2	2000.0	9.000	On	L1	19.7	17.8	60.0	

Final Result 2

Frequency (MHz)	CAverage (dB μ V)	Meas. Time	Bandwidth (kHz)	Filter	Line	Corr. (dB)	Margin (dB)	Limit (dB μ V)	Comment
0.166000	33.2	2000.0	9.000	On	L1	19.8	22.0	55.2	
0.426000	30.0	2000.0	9.000	On	L1	19.7	17.4	47.3	
4.718000	25.9	2000.0	9.000	On	L1	19.6	20.1	46.0	
9.950000	36.8	2000.0	9.000	On	L1	19.7	13.2	50.0	
11.190000	38.0	2000.0	9.000	On	L1	19.7	12.0	50.0	
17.838000	29.4	2000.0	9.000	On	L1	19.7	20.6	50.0	

END OF REPORT