

REVISIONS RECORD					
ZONE	DESCRIPTION	REV.	DATE	ECN. NO.	REDACTOR
	ADD FCC/CE declares label	V02	20110502		Nita Chen

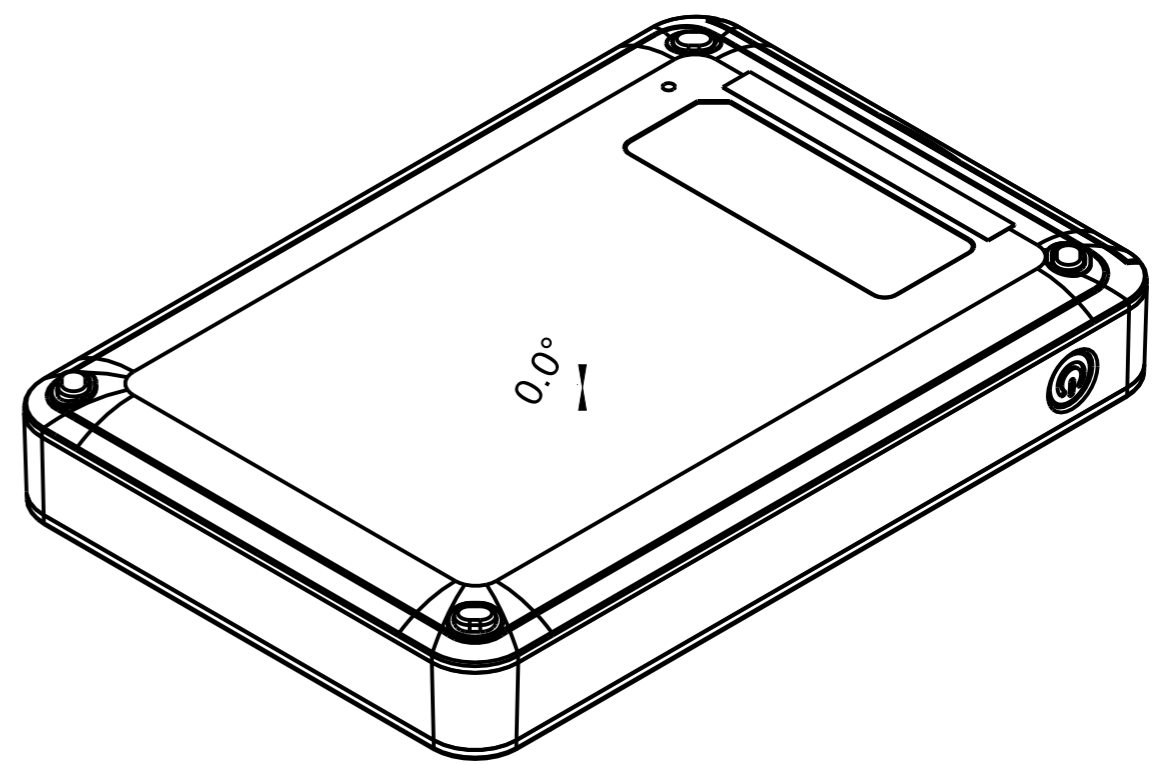
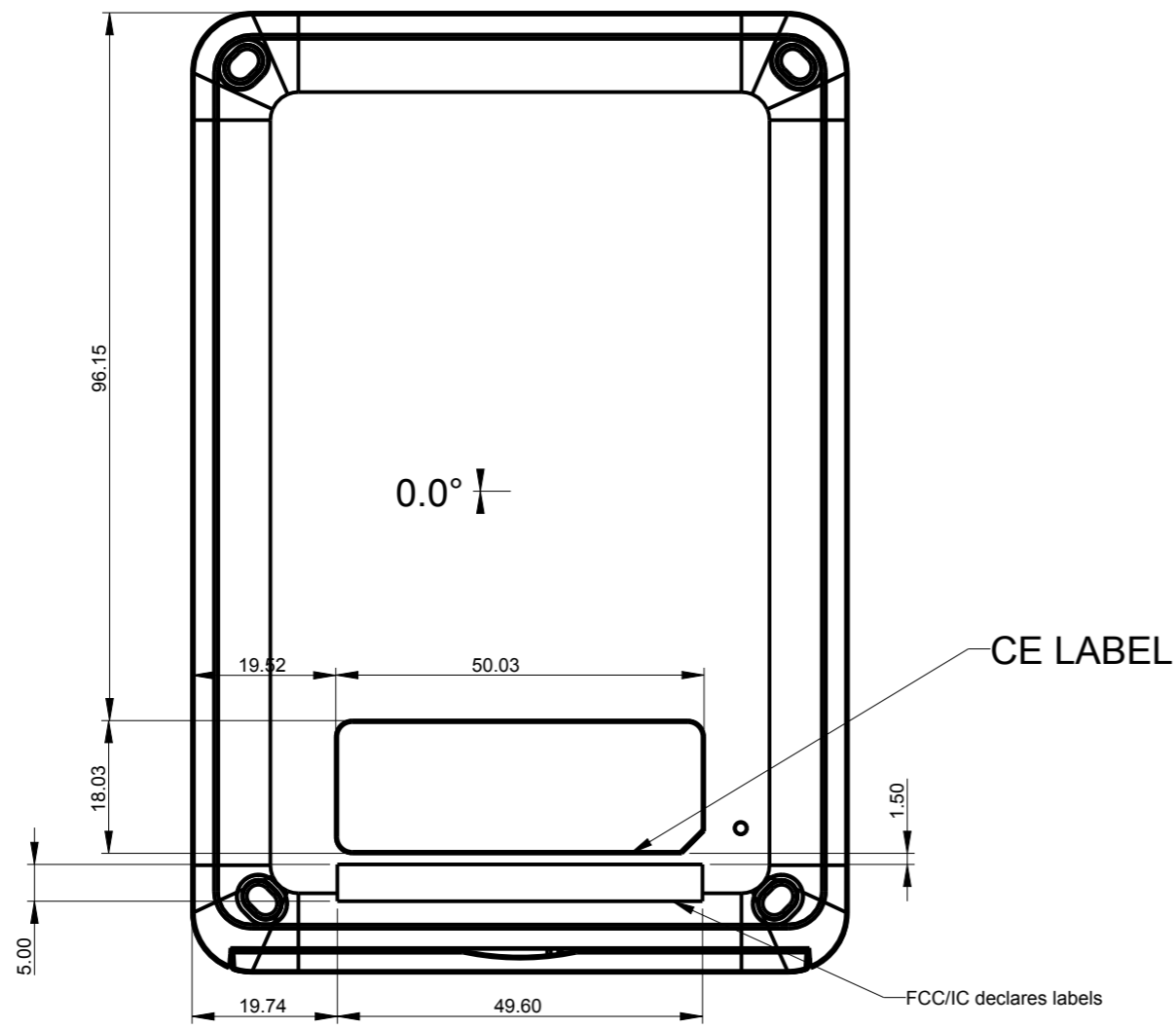

TOLERANCE UNLESS OTHERWISE SPECIFIED (±)	
< 3mm	0.05
3 ~ 15mm	0.08
15 ~ 30mm	0.1
30 ~ 70mm	0.15
70 ~ 120mm	0.2
> 120mm	0.3
ANGLE	1.0

FOXLINK		CHENG UEI PRECISION INDUSTRY CO.,LTD	
<ul style="list-style-type: none"> ■ = CRITICAL DIM ● = TOOLING DIM ▲ = PROCESS DIM (Cpk) MAT'L.: SEE NOTES ⊗ = DIMENSION ID 	INTENDED USE: CE LABEL POSITION	TITLE: CE LABEL POSITION	
	APPD.: Alan Lee	DWG. NO.:	
	CHKD.: Kenny Lee	SCALE: 1	PAGE 1 / 1
	DR.: Nita Chen	UNIT: mm	REV.: V02

Drawing name : ME_SATELLITEW_CE_LABEL / Model name : SATELLITE