

TEST REPORT

REPORT NUMBER: B15X50050-FCC-RF_Rev2

ON

Type of Equipment: Ilium X400 Smart Phone
Type of Designation: Ilium X400
Manufacturer: Shenzhen fortuneship technology, LTD

ACCORDING TO

FCC CFR Part 2, FREQUENCY ALLOCATIONS AND RADIO TREATY MATTERS; GENERAL RULES AND REGULATIONS; e-CFR, Mar 17, 2015

PART 22, PUBLIC MOBILE SERVICES , e-CFR, Mar 17, 2015

PART 24, PERSONAL COMMUNICATIONS SERVICES, e-CFR, Mar 17, 2015

KDB971168 D01 Power Meas License Digital Systems v02r01, June 7, 2013

China Telecommunication Technology Labs.

Month date, year

APR, 9, 2015

Signature



He Guili
Director

FCC ID: ZC4X400
Report Date: 2015-04-09

Test Firm Name: China Telecommunication Technology Labs
Registration Number: 840587

Statement

The measurements shown in this report were made in accordance with the procedures described on test pages. All reported tests were carried out on a sample equipment to demonstrate limited compliance with FCC CFR 47 Parts 2, 22, 24. The sample tested was found to comply with the requirements defined in the applied rules.

CONTENTS

1 GENERAL INFORMATION	4
1.1 NOTES	4
1.2 TESTERS	5
1.3 TESTING LABORATORY INFORMATION	6
1.4 DETAILS OF APPLICANT OR MANUFACTURER.....	7
2 TEST ITEM.....	8
2.1 GENERAL INFORMATION	8
2.2 OUTLINE OF EUT.....	8
2.3 MODIFICATIONS INCORPORATED IN EUT	8
2.4 EQUIPMENT CONFIGURATION	8
2.5 OTHER INFORMATION.....	8
3 SUMMARY OF TEST RESULTS	9
4 TEST RESULTS	11
4.1 RADIATED SPURIOUS EMISSION	11
4.2 OCCUPIED BANDWIDTH.....	18
4.3 FREQUENCY STABILITY OVER TEMPERATURE VARIATION	33
4.4 FREQUENCY STABILITY OVER VOLTAGE VARIATION.....	36
4.5 CONDUCTED RF POWER OUTPUT.....	39
4.6 CONDUCTED SPURIOUS EMISSION.....	44
4.7 BAND EDGE.....	82
4.8 ERP AND EIRP	92
ANNEX A EXTERNAL PHOTOS	99
ANNEX B INTERNAL PHOTOS	99
ANNEX C DEVIATIONS FROM PRESCRIBED TEST METHODS	99

1 General Information

1.1 Notes

All reported tests were carried out on a sample equipment to demonstrate limited compliance with FCC CFR 47 Parts 2, 22, 24.

The test results of this test report relate exclusively to the item(s) tested as specified in section 2.

The following deviation from, additions to, or exclusions from the test specifications have been made. See Annex C.

China Telecommunication Technology Labs. (CTTL) authorizes the applicant or manufacturer (see section 1.4) to reproduce this report provided, and the test report may only be reproduced or published in full. Reproduction or publication of extracts from the report requires the prior written approval of CTTL Mr. He Guili.

Any use which a third party makes of this report, or any reliance on or decisions to be made based on it, are the responsibility of such third parties. CTTL accepts no responsibility for damages, if any, suffered by any third party as a result of decisions made or actions based on this report.

1.2 Testers

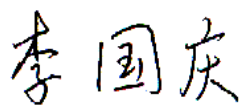
Name: Li Guoqing
Position: Engineer
Department: Department of EMC test
Date: 2015-02-03 to 2015-4-09
Signature: 

Editor of this test report:

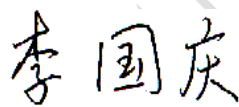
Name: Li Guoqing
Position: Engineer
Department: Department of EMC test
Date: 2015-04-09
Signature: 

Technical responsibility for area of testing:

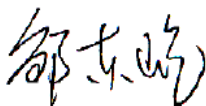
Name: Zou Dongyi
Position: Manager
Department: Department of EMC test
Date: 2015-04-09
Signature: 

1.3 Testing Laboratory information

1.3.1 Location

Name: China Telecommunication Technology Labs.
Address: No. 11, Yue Tan Nan Jie, Xi Cheng District
BEIJING
P. R. CHINA, 100083
Tel: +86 10 68094053
Fax: +86 10 68011404
Email: emc@chinattl.com

1.3.2 Details of accreditation status

Accredited by: China National Accreditation Service for Conformity
Assessment (CNAS)
Registration number: CNAS Registration No. CNAS L0570
Standard: ISO/IEC 17025:2005

1.3.3 Test location, where different from section 1.3.1

Name: -----
Street: -----
City: -----
Country: -----
Telephone: -----
Fax: -----
Postcode: -----

1.4 Details of applicant or manufacturer

1.4.1 Applicant

Name: Coroporativo Lanix S.A. de C.V
Address: Carrterera internacional Hermosillo-Nogales Km 8.5
Country: Mexico
Telephone: 6621090811
Fax: --
Contact: Oscar Guzman
Telephone: 6621090811
Email: Oguzman@lanix.ciim

1.4.2 Manufacturer (if different from applicant in section 1.4.1)

Name: Shenzhen fortuneship technology.,LTD
Address: 6th Floor,Kingson Building, New Energ Innovation
Industrial Park, No.1Chuangsheng Road, Nanshan District,
Shenzhen P.R.China
City: Shenzhen
Country: China

1.4.3 Manufactory (if different from applicant in section 1.4.1)

Name: Shenzhen fortuneship technology, LTD
Address: 6th Floor, Kingson Building,New Energ Innovation
Industrial Park, No.1Chuangsheng Road, Nanshan District,
Shenzhen P.R.China
City: Shenzhen
Country: China

2 Test Item

2.1 General Information

Manufacturer: Shenzhen fortuneship technology.LTD
 Name: Ilium X400 Smart Phone
 Model Number: Ilium X400
 Serial Number: --
 Production Status: Product
 Receipt date of test item: 2015-02-02

2.2 Outline of EUT

E.U.T. is a GSM850/ PCS1900 bands and UMTS/HSDPA/HSUPA FDD II/V bands Terminal Equipment with Bluetooth and wifi.

2.3 Modifications Incorporated in EUT

The EUT has not been modified from what is described by the brand name and unique type identification stated above.

2.4 Equipment Configuration

Equipment configuration list:

Item	Generic Description	Manufacturer	Type	Serial No.	Remarks
A	Mobile Phone	Shenzhen fortuneship technology.LTD	Ilium X400	--	None
B	Battery	None	None	--	None
C	Adaptor	None	None	--	None

2.5 Other Information

--

3 Summary of Test Results

A brief summary of the tests carried out is shown as following.

GSM/GPRS/EGPRS mode:		
Specification Clause	Name of Test	Result
2.1051, 24.238, 2.1053,22.917	Radiated Spurious Emission	Pass
2.1049,22.917(b), 24.238(b)	Occupied Bandwidth	*Note 1
2.1055,22.355, 24.235	Frequency Stability over Temperature Variation	Pass
2.1055,22.355, 24.235	Frequency Stability over Voltage Variation	Pass
2.1046,22.913(a),24.2 32(c)	Conducted RF Power Output	Pass
2.1051,22.917, 24.238	Conducted spurious emissions	Pass
2.1051,24.238, 2.1053, 22.917	Band Edge	Pass
22.913(a), 22.232(b)	ERP and EIRP	Pass
Note 1: No applicable performance criteria.		

WCDMA/HSUPA/HSDPA mode:		
Specification Clause	Name of Test	Result
2.1051, 24.238, 2.1053,22.917	Radiated Spurious Emission	Pass
2.1049,22.917(b), 24.238(b)	Occupied Bandwidth	*Note 2
2.1055,22.355, 24.235	Frequency Stability over Temperature Variation	Pass
2.1055,22.355, 24.235	Frequency Stability over Voltage Variation	Pass
2.1046,22.913(a),24.2 32(c)	Conducted RF Power Output	Pass
2.1051,22.917, 24.238	Conducted spurious emissions	Pass
2.1051,24.238, 2.1053, 22.917	Band Edge	Pass
22.913(a), 24.232(b)	ERP and EIRP	Pass
Note 2: No applicable performance criteria.		

Test equipment Used:						
Asset Number	Description	Manufacturer	Model Number	Serial Number	Cal Due	State
7805	EMI Test Receiver	R/S	ESIB26	100211	2016-03-03	Normal
7330	Ultra Broadband Antenna	R/S	VULB 9160	vulb9160-3252	2015-11-24	Normal
7330	Double-Ridged Horn Antenna	R/S	HF906	100038	2016-01-14	Normal
713	Fully-Anechoic Chamber	ETS	11.8m×6.5m×6.3m	--	2015-11-16	Normal
7330-2	Radio Communications Analyzer	Anritsu	MT8820B	6200772659	2016-01-27	Normal
7330-2	Radio Communications Analyzer	Anritsu	MT8820c	6201026477	2015-08-04	Normal
7330	Signal Generator	R/S	SMY02	100024	2015-10-12	Normal

4 Test Results

4.1 Radiated Spurious Emission

Specifications:	2.1051, 22.917, 2.1053, 22.917
Date of Tests	2015-02-03-2015-03-17
Test conditions:	Ambient Temperature:15°C-35°C Relative Humidity:30%-60% Air pressure: 86-106kPa
Operation Mode	TX on, channel 190 and 661 for GSM/GPRS/EGPRS mode, channel 9400, and 4182 for WCDMA/HSUPA/HSDPA mode.
Test Results:	Pass

Limit Level Construction:

Part 22:

According to Part 22.917(a), i.e., Out of band emissions, the power of any emission outside of the authorized operating frequency ranges must be attenuated below the transmitting power (P) by a factor of at least $43 + 10 \log(P)$ dB, so the limit level is:

$$P(\text{dBm}) - (43 + 10 \log(P)) \text{ dB} = -13\text{dBm}$$

Part 24:

According to Part 24.238 (a), i.e., Out of band emissions, the power of any emission outside of the authorized operating frequency ranges must be attenuated below the transmitting power (P) by a factor of at least $43 + 10 \log(P)$ dB, so the limit level is:

$$P(\text{dBm}) - (43 + 10 \log(P)) \text{ dB} = -13\text{dBm}$$

Test Setup:

The EUT was placed in an anechoic chamber. The Wireless Communications Test Set was used to set the TX channel and power level and modulate the TX signal with different bit patterns.

Test Method:

The measurement method is substitution method accordance with section 2.2.12 of ANSI/TIA-603-C: *Land Mobile FM or PM Communications Equipment Measurement and Performance Standards*.

- (a) Connect the equipment as illustrated and measure the spurious emissions as the method as above.

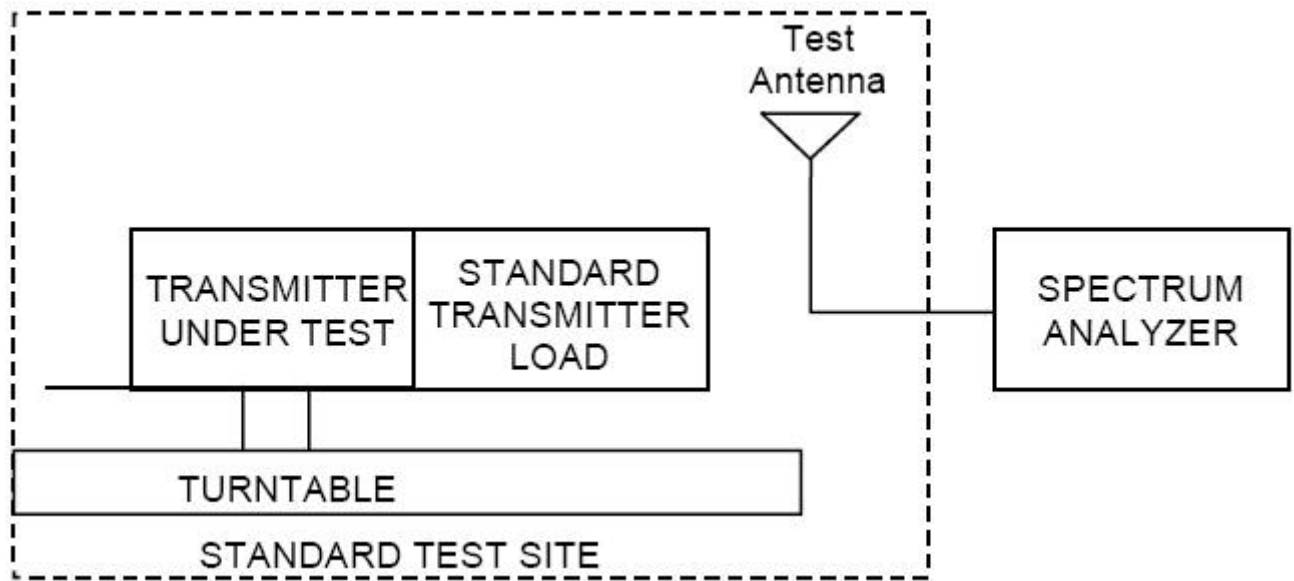

(b) Reconnect the equipment as illustrated.

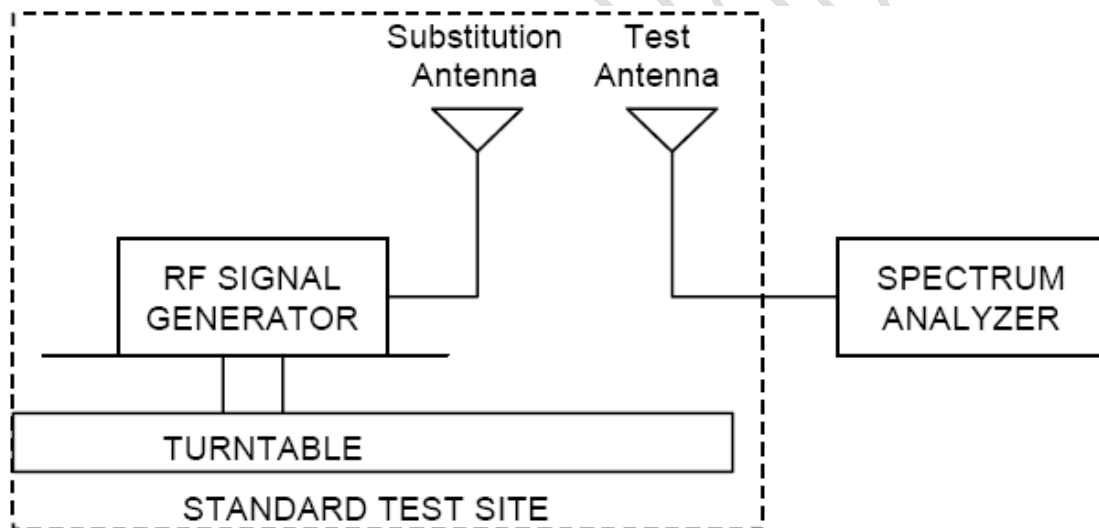

(c) Remove the transmitter and replace it with a substitution antenna. The center of the substitution antenna should be approximately at the same location as the center of the transmitter.

(d) Feed the substitution antenna at the transmitter end with a signal generator connected to the antenna by means of a non-radiating cable. With the antennas at both ends horizontally polarized, and with the signal generator tuned to a particular spurious frequency, raise and lower the test antenna to obtain a maximum reading at the spectrum analyzer. Adjust the level of the signal generator output until the previously recorded maximum reading for this set of conditions is obtained. This should be done carefully repeating the adjustment of the test antenna and generator output.

(e) Repeat step d) with both antennas vertically polarized for each spurious frequency.

(f) Calculate power in dBm into a reference ideal half-wave dipole antenna by reducing the readings obtained in steps d) and e) by the power loss in the cable between the generator and the antenna, and further corrected for the gain of the substitution antenna used

relative to an ideal half-wave dipole antenna by the following formula:

$$P_d(\text{dBm}) = P_g(\text{dBm}) - \text{cable loss (dB)} + \text{antenna gain (dB)}$$

where:

P_d is the dipole equivalent power and

P_g is the generator output power into the substitution antenna.

TTL Test Report

Test Data (GSM channel 190 GMSK Mode)

Frequency [MHz]	Generator output power(P _g) [dBm]	Cable loss [dB]	Antenna Gain [dB]	Spurious Emission Power (P _d) [dBm]	Antenna Polarization [H/V]
1672.8	-20.63	4.7	9.4	-15.93	V
2509.2	-18.99	5.9	10.6	-14.29	V
3345.6	-35.32	6.8	12.6	-29.52	V
4182.0	-36.88	7.8	12.6	-32.08	V
5018.4	-32.86	7.5	12.7	-27.66	V
1672.8	-19.48	4.7	9.4	-14.78	H
2509.2	-20.87	5.9	10.6	-16.17	H
3345.6	-35.98	6.8	12.6	-30.18	H
4182.0	-35.25	7.8	12.6	-30.45	H
5018.4	-32.29	7.5	12.7	-27.09	H

Test Data (GSM channel 661 GMSK Mode)

Frequency [MHz]	Generator output power(P _g) [dBm]	Cable loss [dB]	Antenna Gain [dB]	Spurious Emission Power (P _d) [dBm]	Antenna Polarization [H/V]
3760.0	-44.29	7.3	12.6	-38.99	V
5840.0	-52.23	1.1	13.1	-40.23	V
7520.0	-35.08	0.8	11.5	-24.38	V
9400.0	-40.67	0.8	12.0	-29.47	V
11280.0	-33.72	0.3	11.5	-22.52	V
3760.0	-44.10	7.3	12.6	-38.80	H
5840.0	-52.78	1.1	13.1	-40.78	H
7520.0	-35.48	0.8	11.5	-24.78	H
9400.0	-38.26	0.8	12.0	-27.06	H
11280.0	-38.35	0.3	11.5	-27.15	H

Test Data (EGPRS channel 190 8PSK Mode)

Frequency [MHz]	Generator output power(P _g) [dBm]	Cable loss [dB]	Antenna Gain [dB]	Spurious Emission Power (P _d) [dBm]	Antenna Polarization [H/V]
1672.8	-21.39	4.7	9.4	-16.69	V
2509.2	-19.67	5.9	10.6	-14.97	V
3345.6	-49.98	6.8	12.6	-44.18	V
4182.0	-59.54	7.8	12.6	-54.74	V
5018.4	-50.88	7.5	12.7	-45.68	V
1672.8	-19.43	4.7	9.4	-14.73	H
2509.2	-19.83	5.9	10.6	-15.13	H
3345.6	-51.02	6.8	12.6	-45.22	H
4182.0	-51.73	7.8	12.6	-46.93	H
5018.4	-55.75	7.5	12.7	-50.55	H

Test Data (EGPRS channel 661 8PSK Mode)

Frequency [MHz]	Generator output power(P _g) [dBm]	Cable loss [dB]	Antenna Gain [dB]	Spurious Emission Power (P _d) [dBm]	Antenna Polarization [H/V]
3760.0	-48.97	7.3	12.6	-43.67	V
5840.0	-54.29	1.1	13.1	-42.29	V
7520.0	-49.93	0.8	11.5	-39.23	V
9400.0	-47.45	0.8	12.0	-36.25	V
11280.0	-50.03	0.3	11.5	-38.83	V
3760.0	-44.34	7.3	12.6	-39.04	H
5840.0	-53.96	1.1	13.1	-41.96	H
7520.0	-41.5	0.8	11.5	-30.8	H
9400.0	-50.67	0.8	12.0	-39.47	H
11280.0	-50.98	0.3	11.5	-39.78	H

Test Data (WCDMA channel 9400 QPSK Mode)

Frequency [MHz]	Generator output power(P _g) [dBm]	Cable loss [dB]	Antenna Gain [dB]	Spurious Emission Power (P _d) [dBm]	Antenna Polarization [H/V]
3760.0	-33.81	7.3	12.6	-28.51	V
5840.0	-49.86	1.1	13.1	-37.86	V
7520.0	-40.73	0.8	11.5	-30.03	V
9400.0	-47.89	0.8	12.0	-36.69	V
11280.0	-49.67	0.3	11.5	-38.47	V
3760.0	-30.86	7.3	12.6	-25.56	H
5840.0	-49.64	1.1	13.1	-37.64	H
7520.0	-43.57	0.8	11.5	-32.87	H
9400.0	-46.73	0.8	12.0	-35.53	H
11280.0	-49.32	0.3	11.5	-38.12	H

Test Data (WCDMA channel 4182 QPSK Mode)

Frequency [MHz]	Generator output power(P _g) [dBm]	Cable loss [dB]	Antenna Gain [dB]	Spurious Emission Power (P _d) [dBm]	Antenna Polarization [H/V]
1672.8	-19.1	4.7	9.4	-14.40	V
2509.2	-18.43	5.9	10.6	-13.73	V
3345.6	-48.9	6.8	12.6	-43.10	V
4182.0	-41.78	7.8	12.6	-36.98	V
5018.4	-50.23	7.5	12.7	-45.03	V
1672.8	-18.93	4.7	9.4	-14.23	H
2509.2	-18.87	5.9	10.6	-14.17	H
3345.6	-43.22	6.8	12.6	-37.42	H
4182.0	-38.06	7.8	12.6	-33.26	H
5018.4	-48.95	7.5	12.7	-43.75	H

Test Data (HSDPA/HSUPA channel 9400 16QAM Mode)

Frequency [MHz]	Generator output power(P _g) [dBm]	Cable loss [dB]	Antenna Gain [dB]	Spurious Emission Power (P _d) [dBm]	Antenna Polarization [H/V]
3760.0	-33.23	7.3	12.6	-27.93	V
5840.0	-50.73	1.1	13.1	-38.73	V
7520.0	-45.21	0.8	11.5	-34.51	V
9400.0	-49.98	0.8	12.0	-38.78	V
11280.0	-49.45	0.3	11.5	-38.25	V
3760.0	-32.96	7.3	12.6	-27.66	H
5840.0	-49.6	1.1	13.1	-37.6	H
7520.0	-43.01	0.8	11.5	-32.31	H
9400.0	-50.23	0.8	12.0	-39.03	H
11280.0	-49.93	0.3	11.5	-38.73	H

Test Data (HSDPA/HSUPA channel 4182 16QAM Mode)

Frequency [MHz]	Generator output power(P _g) [dBm]	Cable loss [dB]	Antenna Gain [dB]	Spurious Emission Power (P _d) [dBm]	Antenna Polarization [H/V]
1672.8	-19.52	4.7	9.4	-14.82	V
2509.2	-18.59	5.9	10.6	-13.89	V
3345.6	-41.79	6.8	12.6	-35.99	V
4182.0	-38.83	7.8	12.6	-34.03	V
5018.4	-54.56	7.5	12.7	-49.36	V
1672.8	-19.74	4.7	9.4	-15.04	H
2509.2	-19.13	5.9	10.6	-14.43	H
3345.6	-42.87	6.8	12.6	-37.07	H
4182.0	-40.53	7.8	12.6	-35.73	H
5018.4	-53.12	7.5	12.7	-47.92	H

4.2 Occupied bandwidth

Specifications:	2.1049,22.917(b),24.238(b)
Date of Test	2015-02-07-2015-02-09
Test conditions:	Ambient Temperature:15°C-35°C Relative Humidity:30%-60% Air pressure: 86-106kPa
Operation Mode	TX on, channel 128, 190, 251 and 512, 661, 810 for GSM/GPRS/EGPRS mode, channel 4132, 4182, 4233 and 9262, 9400, 9538 for WCDMA/HSUPA/HSDPA mode.
Test Results:	--

Test Setup

During the test, the EUT was controlled via the Wireless Communications Test Set to ensure max power transmission and proper modulation and measured by spectrum analyzer.

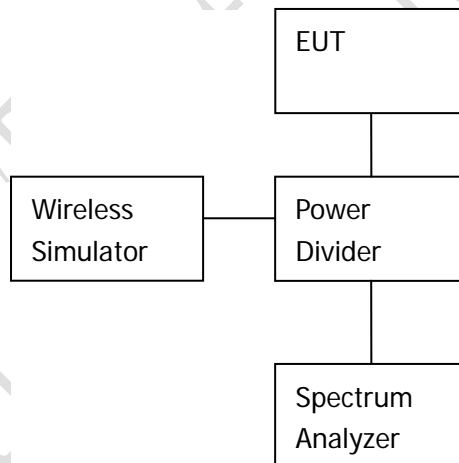

Test Method

The 99% occupied bandwidth was calculated from the spectrum analyzer. Markers in the spectrum analyzer were then placed between the calculated frequencies to show the calculated 99% power band.

Note:

None

Test Data:

GSM/GPRS/EDGE mode

	EUT channel no.	99% occupied bandwidth [kHz]
GMSK	128 (824.2MHz)	243.58
	190 (836.4MHz)	246.79
	251 (848.8MHz)	243.58
	512 (1850.2MHz)	240.38
	661 (1880 MHz)	243.58
	810 (1909.8 MHz)	243.58
8PSK	128 (824.2MHz)	243.58
	190 (836.4MHz)	243.58
	251 (848.8MHz)	243.58
	512 (1850.2MHz)	246.79
	661 (1880 MHz)	243.58
	810 (1909.8 MHz)	246.79

Graphical results for GSM/GPRS/EDGE mode:

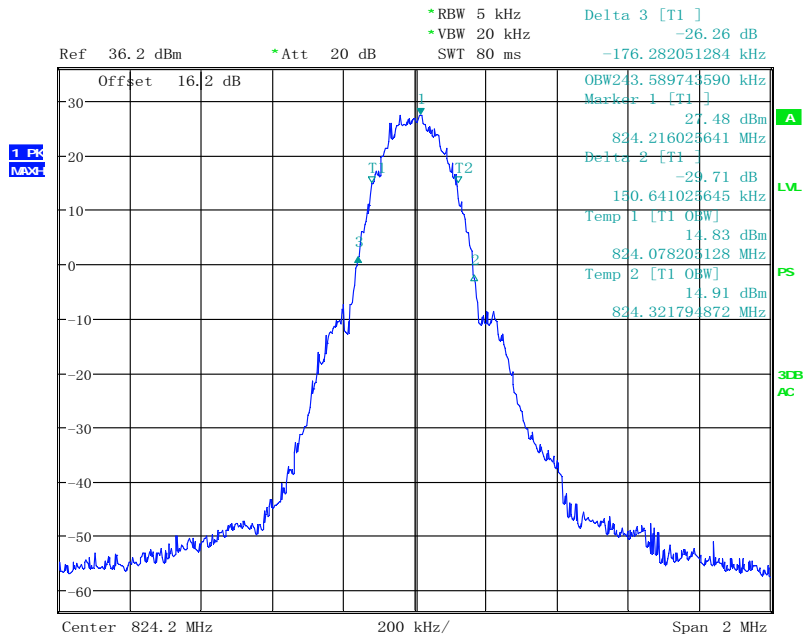

Date: 7. FEB. 2015 11:18:10

GMSK Channel 128

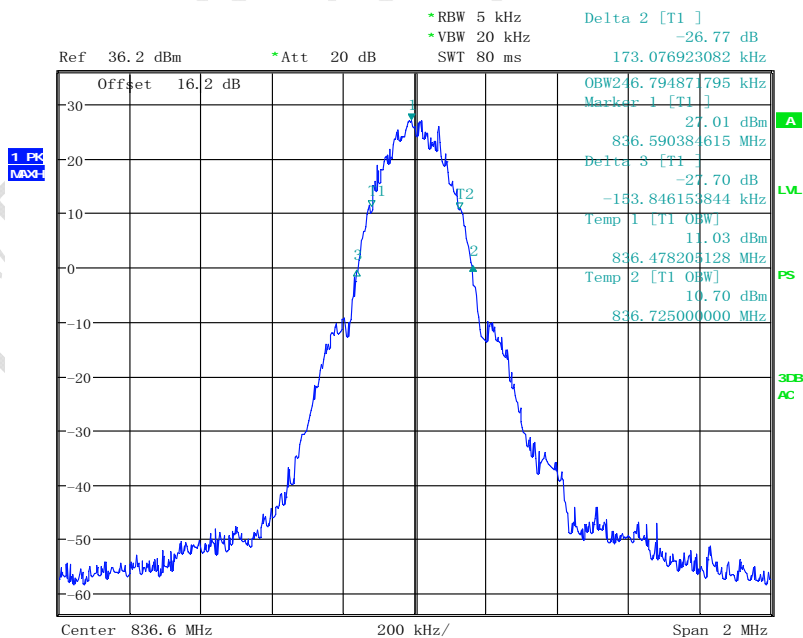

Date: 7. FEB. 2015 11:18:46

GMSK Channel 190

FCC Parts 2, 22, 24
Equipment: Ilium X400

REPORT NO.: B15X50050-FCC-RF_Rev2

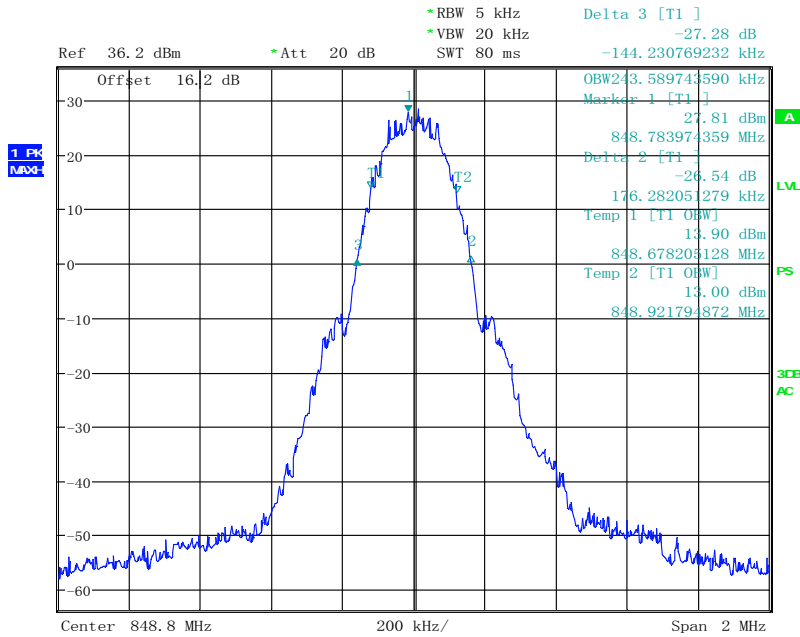

Date: 7. FEB. 2015 11:20:01

GMSK Channel 251

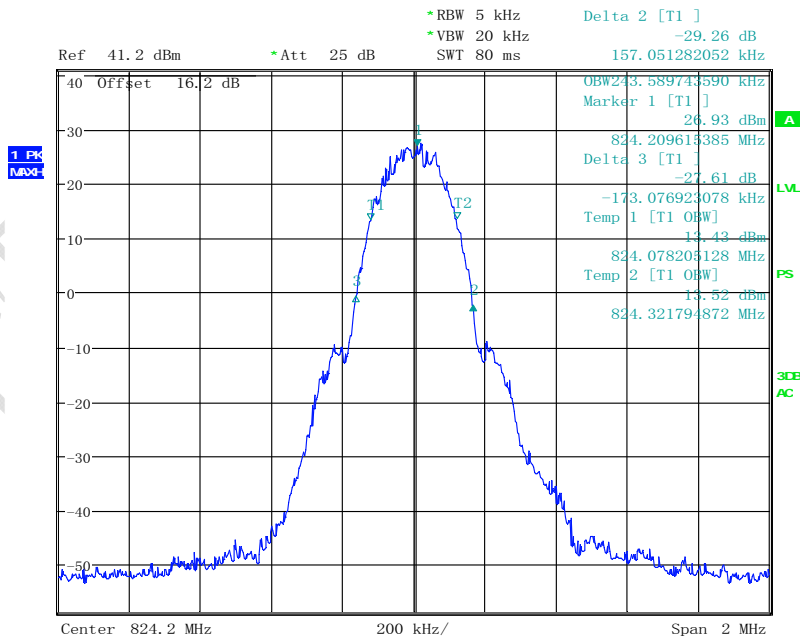

Date: 7. FEB. 2015 11:03:05

8PSK Channel 128

FCC Parts 2, 22, 24
Equipment: Ilium X400

REPORT NO.: B15X50050-FCC-RF_Rev2

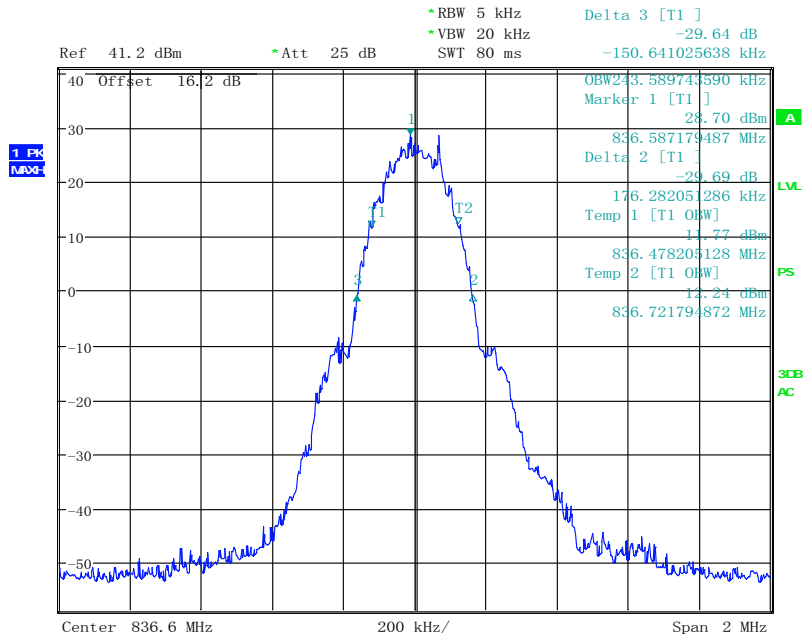

Date: 7. FEB. 2015 11:04:08

8PSK Channel 190

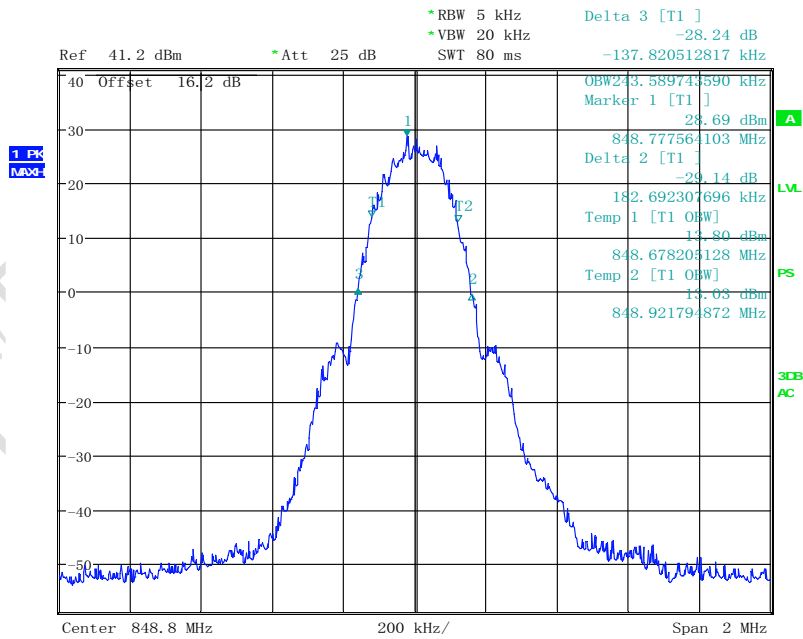

Date: 7. FEB. 2015 11:05:02

8PSK Channel 251

FCC Parts 2, 22, 24
Equipment: Ilium X400

REPORT NO.: B15X50050-FCC-RF_Rev2

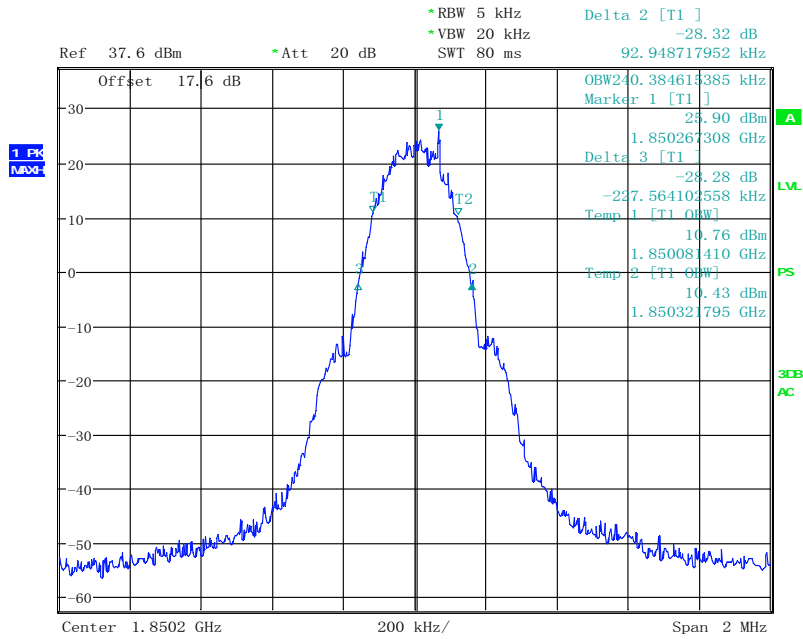

Date: 7. FEB. 2015 11:47:13

GMSK Channel 512

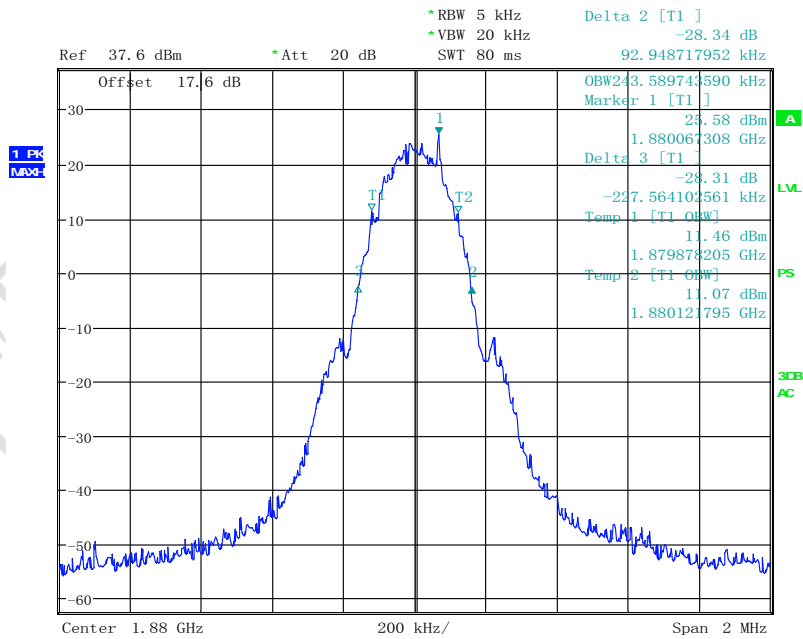

Date: 7. FEB. 2015 11:46:26

GMSK Channel 661

FCC Parts 2, 22, 24
Equipment: Ilium X400

REPORT NO.: B15X50050-FCC-RF_Rev2

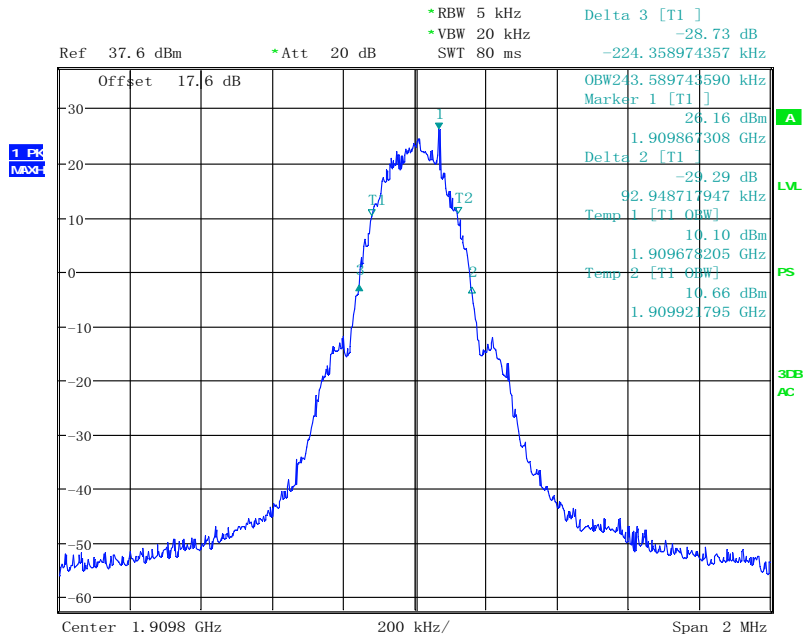

Date: 7. FEB. 2015 11:45:31

GMSK Channel 810

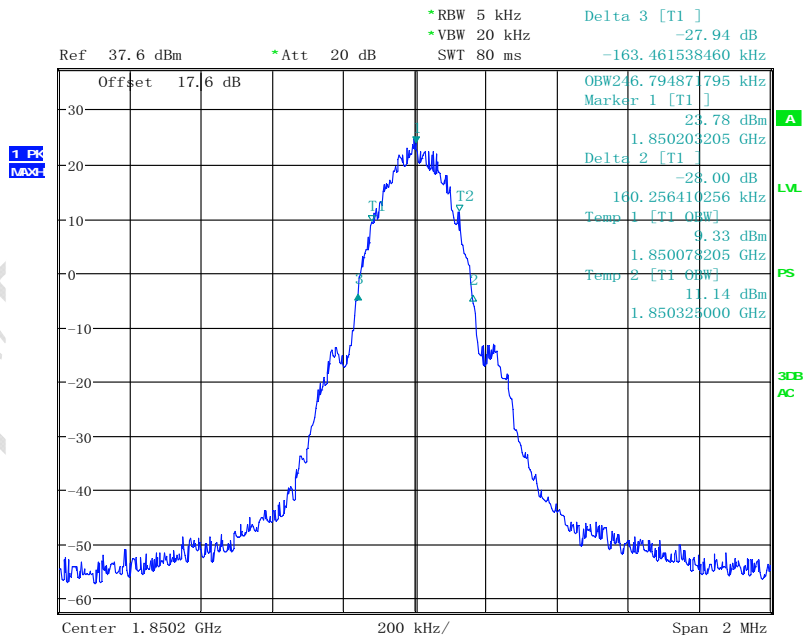

Date: 7. FEB. 2015 11:36:43

8PSK Channel 512

FCC Parts 2, 22, 24
Equipment: Ilium X400

REPORT NO.: B15X50050-FCC-RF_Rev2

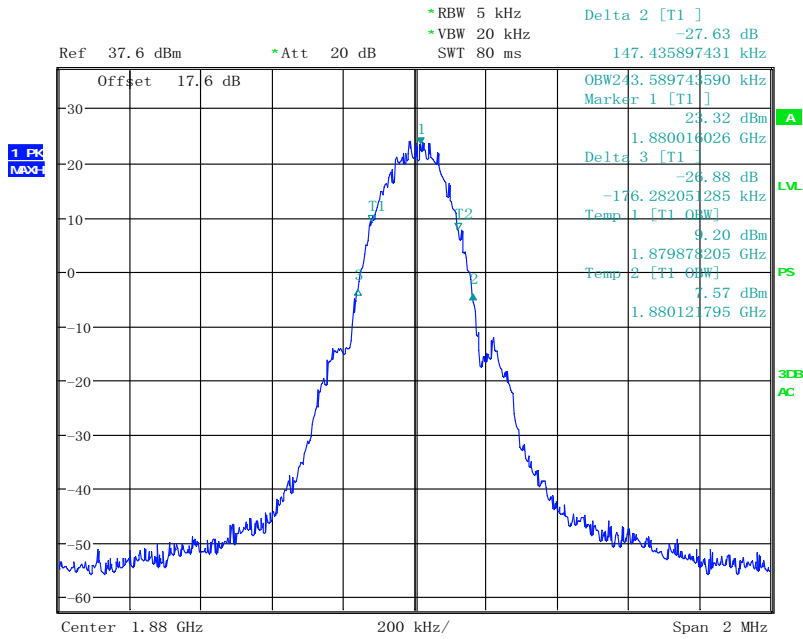

Date: 7.FEB.2015 11:37:27

8PSK Channel 661

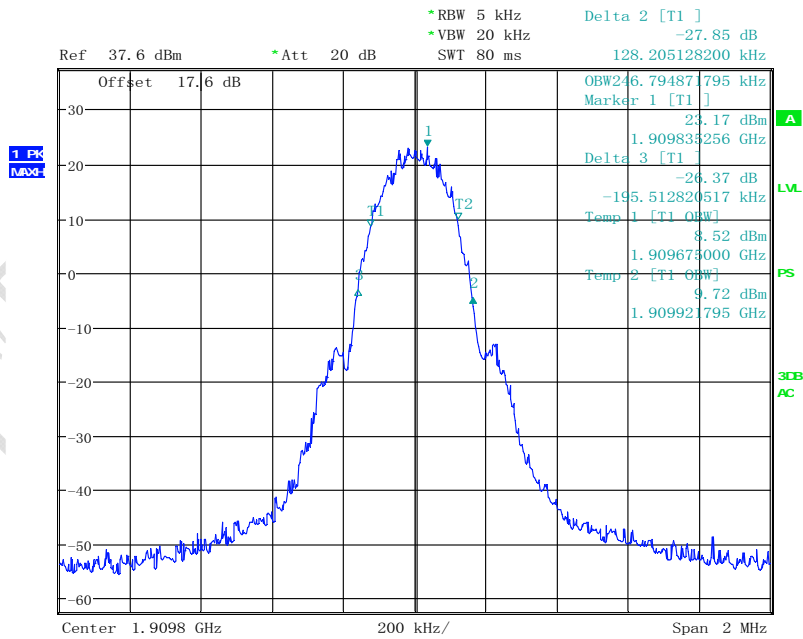

Date: 7.FEB.2015 11:38:23

8PSK Channel 810

WCDMA/HSDPA/HSUPA mode

	EUT channel no.	99% occupied bandwidth [MHz]
QPSK	4132 (826.4MHz)	4.1666
	4182 (836.4MHz)	4.1666
	4233 (846.6MHz)	4.1666
	9262 (1852.4MHz)	4.1987
	9400 (1880 MHz)	4.1666
	9538 (1907.5 MHz)	4.1666
16QAM	4132 (826.4MHz)	4.1666
	4182 (836.4MHz)	4.1666
	4233 (846.6MHz)	4.1666
	9262 (1852.4MHz)	4.1666
	9400 (1880 MHz)	4.1666
	9538 (1907.5 MHz)	4.1666

Graphical results for WCDMA/HSDPA/HSUPA mode:

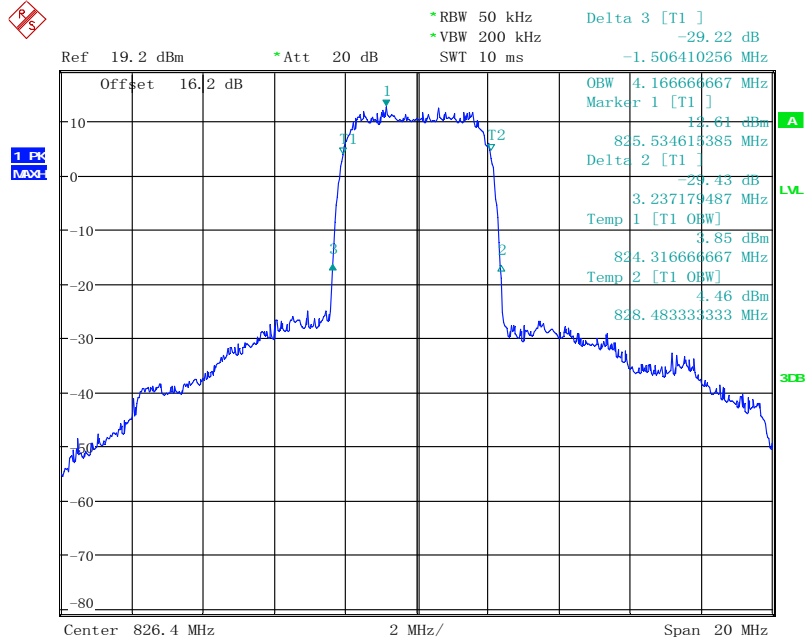

Date: 9. FEB. 2015 08:46:31

QPSK Channel 4132

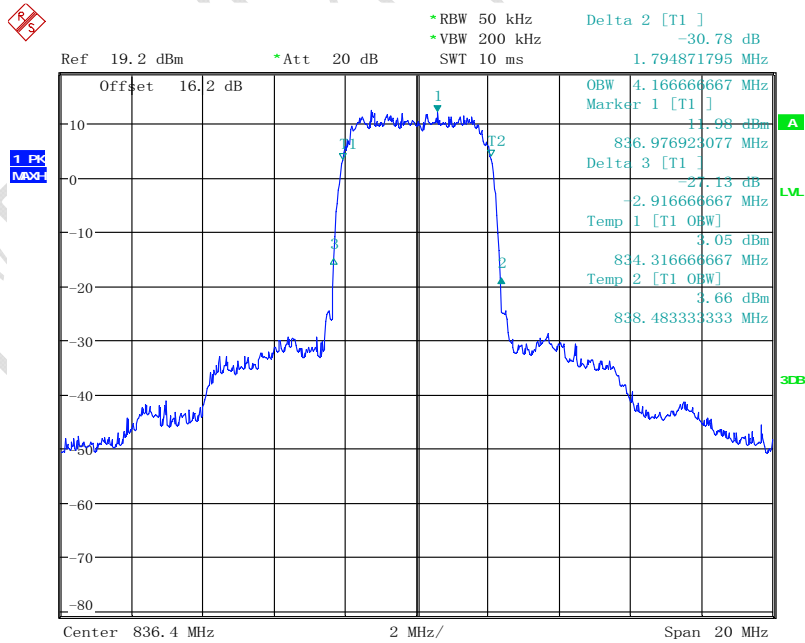

Date: 9. FEB. 2015 08:47:36

QPSK Channel 4182

FCC Parts 2, 22, 24
Equipment: Ilium X400

REPORT NO.: B15X50050-FCC-RF_Rev2

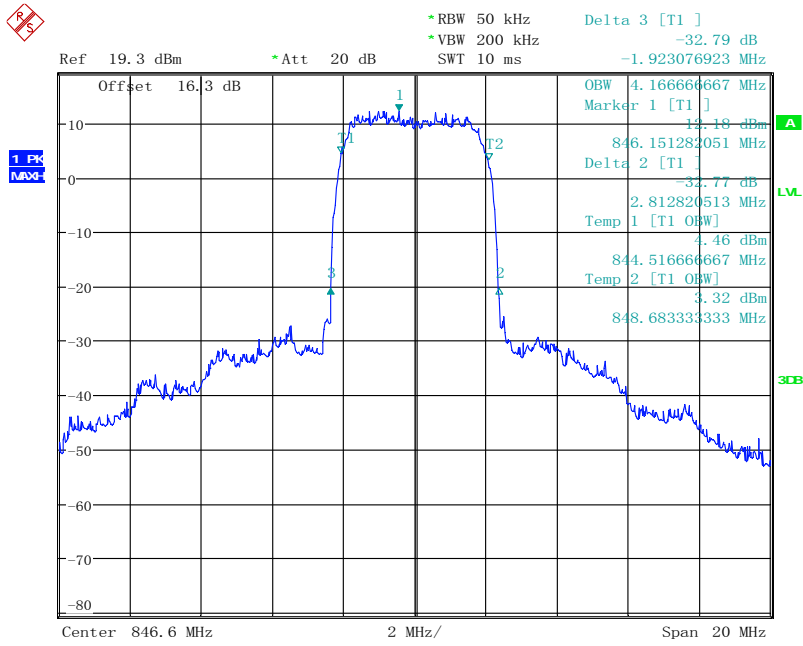

Date: 9.FEB.2015 08:49:10

QPSK Channel 4233

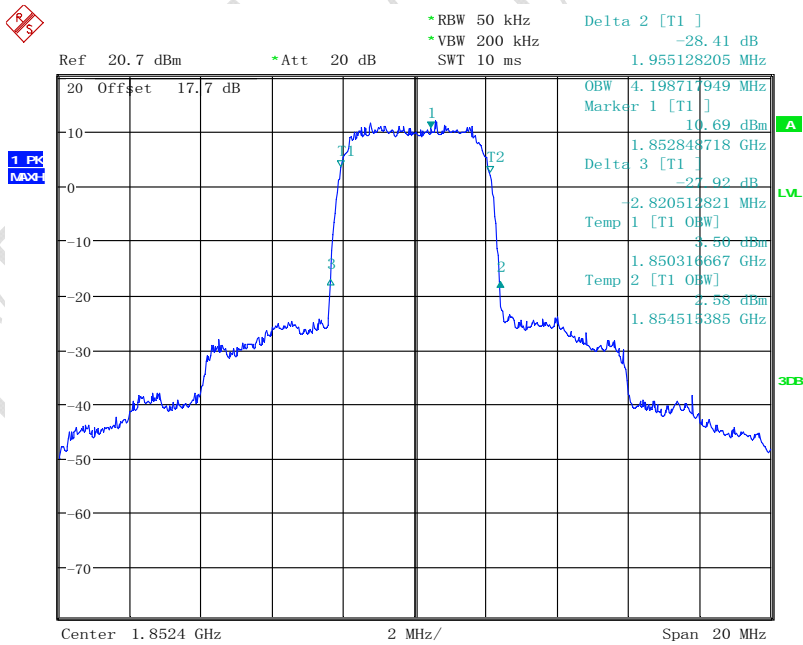

Date: 9.FEB.2015 07:53:54

QPSK Channel 9262

FCC Parts 2, 22, 24
Equipment: Ilium X400

REPORT NO.: B15X50050-FCC-RF_Rev2

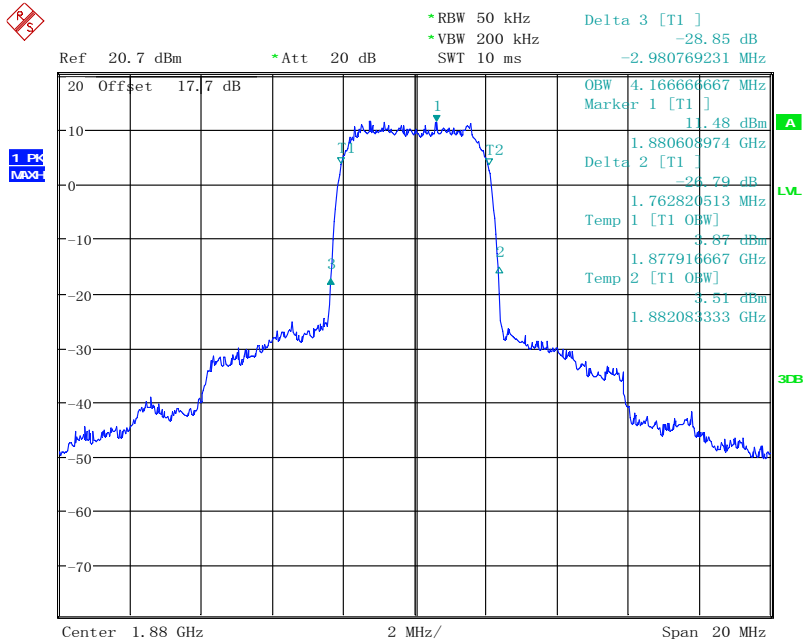

Date: 9.FEB.2015 07:54:45

QPSK Channel 9400

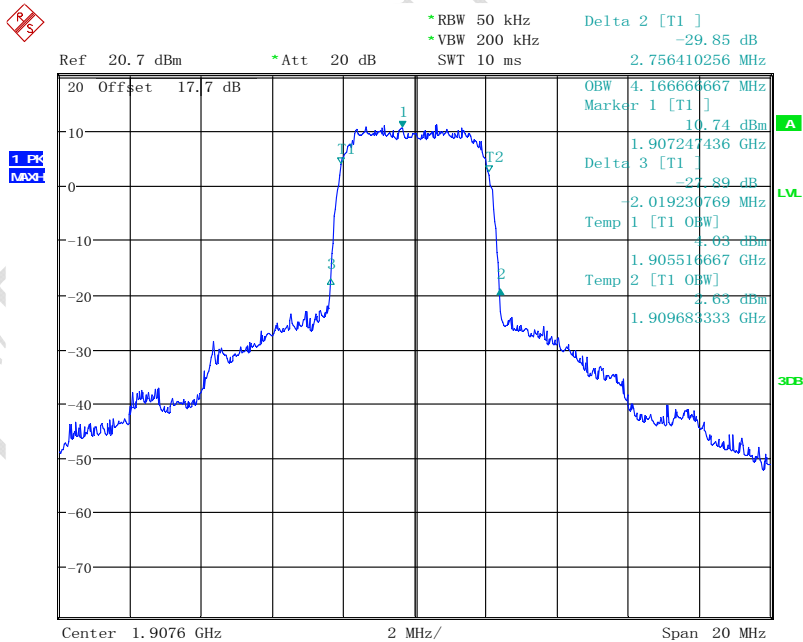

Date: 9.FEB.2015 07:55:31

QPSK Channel 9538

FCC Parts 2, 22, 24
Equipment: Ilium X400

REPORT NO.: B15X50050-FCC-RF_Rev2

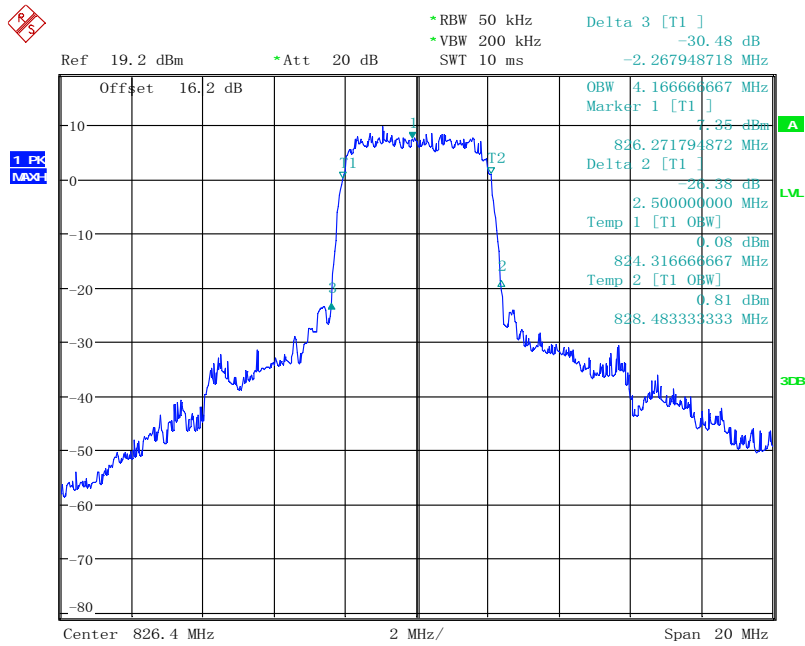

Date: 9.FEB.2015 08:51:59

16QAM Channel 4132

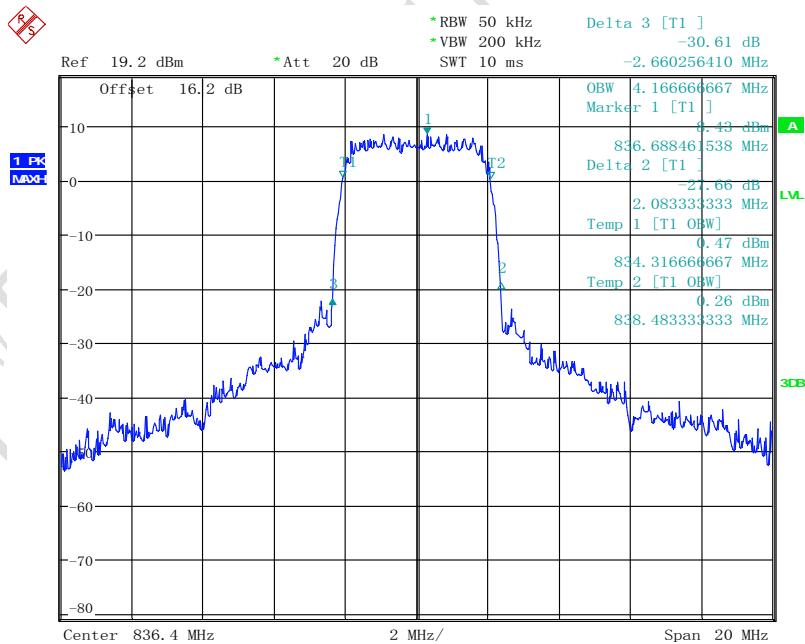

Date: 9.FEB.2015 08:52:35

16QAM Channel 4182

FCC Parts 2, 22, 24
Equipment: Ilium X400

REPORT NO.: B15X50050-FCC-RF_Rev2

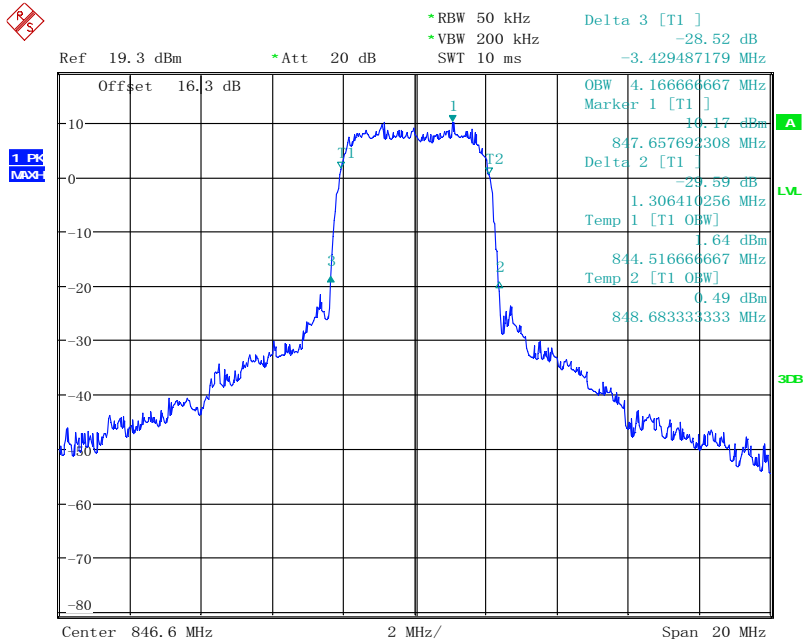

Date: 9.FEB.2015 10:51:07

16QAM Channel 4233

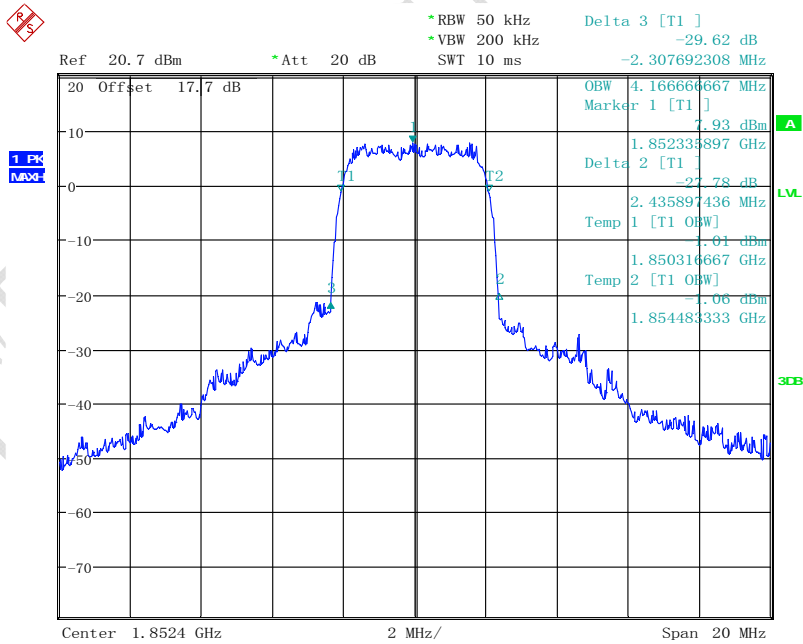

Date: 9.FEB.2015 07:59:47

16QAM Channel 9262

FCC Parts 2, 22, 24
Equipment: Ilium X400

REPORT NO.: B15X50050-FCC-RF_Rev2

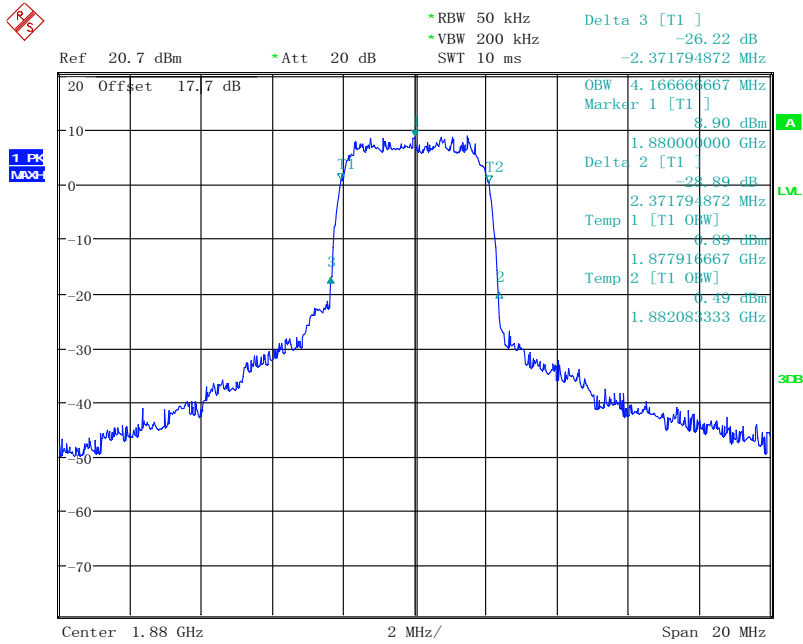

Date: 9.FEB.2015 08:00:45

16QAM Channel 9400

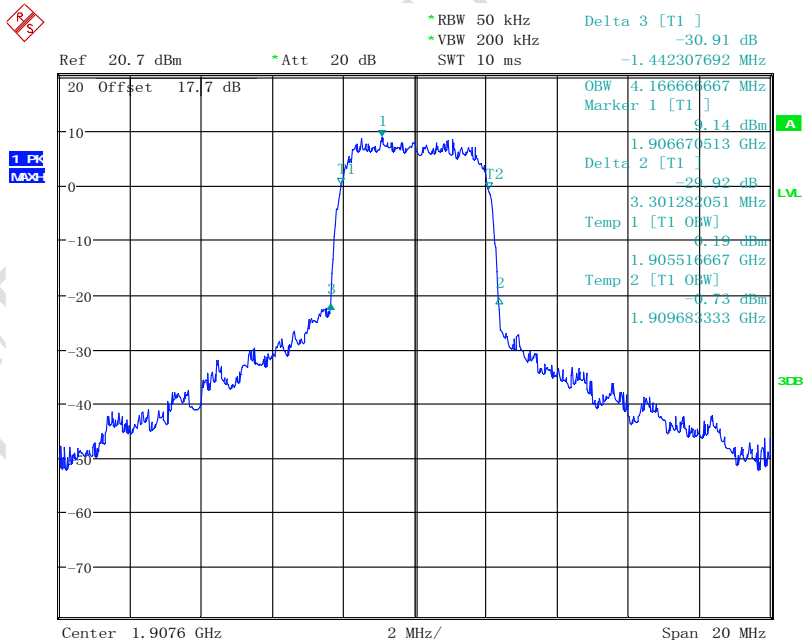

Date: 9.FEB.2015 08:01:43

16QAM Channel 9538

4.3 Frequency Stability over Temperature Variation

Specifications:	2.1055,22.355,24.235
Date of Test	2015-02-08-2015-02-10
Test conditions:	Ambient Temperature:-30°C-50°C Relative Humidity:30%-60% Air pressure: 86-106kPa
Operation Mode	TX on, channel 190 and 661 for GSM/GPRS/EGPRS mode, channel 4182, and 9400 for WCDMA/HSUPA/HSDPA mode.
Test Results:	Pass

Limit	
Frequency deviation [ppm]	±2.5

Test Setup

The EUT was placed in a temperature chamber, demonstrated as figure T. The Wireless Telecommunications Test Set was used to set the Tx channel and power level, modulate the TX signal with different bit patterns and measure the frequency of Tx.

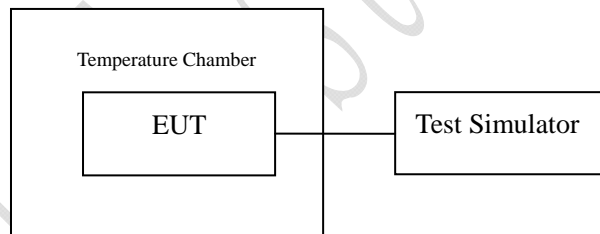

Figure T: setup for measurement of frequency stability over temperature variation

Test Method

1. The EUT was turned off and placed in the temperature chamber.
2. The temperature of the chamber was set to -30°C and allowed to stabilize.
3. The EUT temperature was allowed to stabilize for 45 minutes.
4. The EUT was turned on and set to transmit with Wireless Telecommunications Test Set.
5. The maximum transmit frequency deviation during one minute period was measured by Wireless Communications Test Set.
6. The steps 3-5 were repeated for -30°C, -20°C, -10°C, 0°C, 10°C, 20°C, 30°C, 40°C and 50°C.

Test data:

GSM/GPRS/EDGE 850 band mode

	Temperature[°C]	Offset[Hz]	Offset[ppm]	Remarks
GMSK	-30	35	0.04183	Pass
	-20	26	0.03107	Pass
	-10	16	0.01912	Pass
	0	-29	-0.03466	Pass
	10	42	0.05020	Pass
	20	19	0.02271	Pass
	30	27	0.03227	Pass
	40	34	0.04064	Pass
	50	26	0.03107	Pass
8PSK	-30	27	0.03227	Pass
	-20	-19	-0.02271	Pass
	-10	34	0.04064	Pass
	0	43	0.05139	Pass
	10	29	0.03466	Pass
	20	18	0.02151	Pass
	30	-25	-0.02988	Pass
	40	-23	-0.02749	Pass
	50	30	0.03585	Pass

GSM/GPRS/EDGE 1900 band mode

	Temperature[°C]	Offset[Hz]	Offset[ppm]	Remarks
GMSK	-30	28	0.01489	Pass
	-20	32	0.01702	Pass
	-10	45	0.02393	Pass
	0	-33	-0.01755	Pass
	10	25	0.01329	Pass
	20	12	0.00638	Pass
	30	-21	-0.01117	Pass
	40	40	0.02127	Pass
	50	29	0.01542	Pass
8PSK	-30	19	0.01010	Pass
	-20	41	0.02180	Pass
	-10	35	0.01861	Pass
	0	-27	-0.01436	Pass
	10	33	0.01755	Pass
	20	38	0.02021	Pass
	30	26	0.01383	Pass
	40	-29	-0.01543	Pass
	50	17	0.00904	Pass

WCDMA/HSDPA/HSUPA FDD 850MHz band mode:

	Temperature[°C]	Offset[Hz]	Offset[ppm]	Remarks
QPSK	-30	46	0.05499	Pass
	-20	34	0.04065	Pass
	-10	37	0.04423	Pass
	0	-29	-0.03467	Pass
	10	27	0.03228	Pass
	20	33	0.03945	Pass
	30	25	0.02989	Pass
	40	41	0.04902	Pass
	50	-26	-0.03109	Pass
16QAM	-30	35	0.04184	Pass
	-20	47	0.05619	Pass
	-10	24	0.02869	Pass
	0	29	0.03467	Pass
	10	-21	-0.02511	Pass
	20	-26	-0.03109	Pass
	30	43	0.05141	Pass
	40	22	0.02630	Pass
	50	40	0.04782	Pass

WCDMA/HSDPA/HSUPA FDD 1900MHz band mode:

	Temperature[°C]	Offset[Hz]	Offset[ppm]	Remarks
QPSK	-30	23	0.01223	Pass
	-20	45	0.02393	Pass
	-10	32	0.01702	Pass
	0	28	0.01489	Pass
	10	-21	-0.01117	Pass
	20	-17	-0.00904	Pass
	30	37	0.01968	Pass
	40	29	0.01542	Pass
	50	42	0.02234	Pass
16QAM	-30	25	0.01329	Pass
	-20	33	0.01755	Pass
	-10	-19	-0.01011	Pass
	0	42	0.02234	Pass
	10	31	0.01648	Pass
	20	36	0.01914	Pass
	30	-29	-0.01543	Pass
	40	37	0.01968	Pass
	50	28	0.01489	Pass

4.4 Frequency Stability over Voltage Variation

Specifications:	2.1055,22.355,24.235
Date of Test	2015-02-10-2015-02-12
Test conditions:	Ambient Temperature:15°C-35°C Relative Humidity:30%-60% Air pressure: 86-106kPa
Operation Mode	TX on, channel 190 and 661 for GSM/GPRS/EGPRS mode, channel 4182, and 9400 for WCDMA/HSUPA/HSDPA mode.
Test Results:	Pass

Limit	
Frequency deviation [ppm]	±2.5

Test Setup

The EUT was placed in a shielding chamber and powered by an adjustable power supply, demonstrated as figure V. A Wireless Telecommunications Test Set was used to set the TX channel and power level, modulate the TX signal with different bit patterns and measure the frequency of TX.

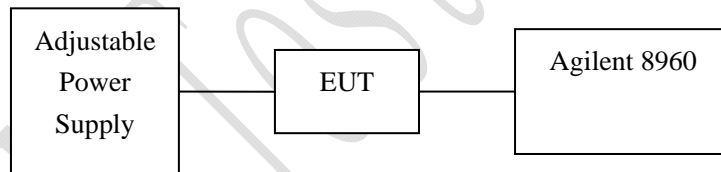

Figure V: test setup for measurement of frequency stability over voltage variation

Test Method

The EUT was powered by the adjustable power supply. The frequency stability is measured by the Wireless Telecommunications Test Set.

Test data:

GSM/GPRS/EDGE 850MHz band GMSK mode

Voltage (V)	Offset[Hz]	Offset[ppm]	Remarks
4.5	29	0.03466	Pass
5.0	17	0.02032	Pass
5.5	19	0.02271	Pass

GSM/GPRS/EDGE 850MHz band 8PSK mode

Voltage (V)	Offset[Hz]	Offset[ppm]	Remarks
4.5	27	0.03227	Pass
5.0	24	0.02868	Pass
5.5	26	0.03107	Pass

GSM/GPRS/EDGE 1900MHz band GMSK mode

Voltage (V)	Offset[Hz]	Offset[ppm]	Remarks
4.5	54	0.02872	Pass
5.0	48	0.02553	Pass
5.5	50	0.02659	Pass

GSM/GPRS/EDGE 1900MHz band 8PSK mode

Voltage (V)	Offset[Hz]	Offset[ppm]	Remarks
4.5	44	0.02340	Pass
5.0	20	0.01063	Pass
5.5	22	0.01170	Pass

WCDMA/HSDPA/HSUPA FDD 850MHz band QPSK mode:

Voltage (V)	Offset[Hz]	Offset[ppm]	Remarks
4.5	26	0.03108	Pass
5.0	-8	-0.00956	Pass
5.5	-9	-0.01076	Pass

WCDMA/HSDPA/HSUPA FDD 850MHz band 16QAM mode:

Voltage (V)	Offset[Hz]	Offset[ppm]	Remarks
4.5	19	0.02271	Pass
5.0	15	0.01793	Pass
5.5	30	0.03586	Pass

WCDMA/HSDPA/HSUPA FDD 1900MHz band QPSK mode:

Voltage (V)	Offset[Hz]	Offset[ppm]	Remarks
4.5	13	0.00691	Pass
5.0	14	0.00744	Pass
5.5	34	0.01808	Pass

WCDMA/HSDPA/HSUPA FDD 1900MHz band 16QAM mode:

Voltage (V)	Offset[Hz]	Offset[ppm]	Remarks
4.5	27	0.01436	Pass
5.0	18	0.00957	Pass
5.5	36	0.01914	Pass

TTL Test Report

4.5 Conducted RF Power Output

Specifications:	2.1046,22.913(a),24.232(c)
Date of Tests	2015-02-07-2015-04-09
Test conditions:	Ambient Temperature:15°C-35°C Relative Humidity:30%-60% Air pressure: 86-106kPa
Operation Mode	TX on, channel 128, 190, 251 and 512, 661, 810 for GSM/GPRS/EGPRS mode, channel 4132, 4182, 4233 and 9262, 9400, 9538 for WCDMA/HSUPA/HSDPA mode.
Test Results:	Pass

Limit Level Construction: ERP: According to Part 22.913(a) and 24.232(c), the ERP of mobile transmitters and auxiliary test transmitters must not exceed 7 Watts.	
Limits for ERP	
Frequency range	Limit Level (ERP)
TX channel	7W or 38.5dBm

Test Setup:

During the test, the EUT was controlled via the Wireless Communications Test Set to ensure max power transmission and proper modulation and measured by spectrum analyzer.

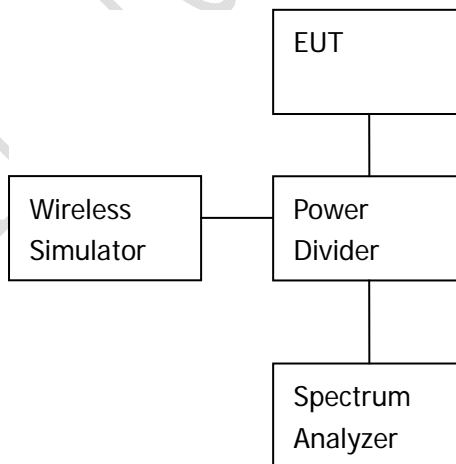

Test Method

- 1) The EUT was coupled to the spectrum analyzer and the base station simulator through a power divider. The lost of the cables the test system is calibrated to correct the readings.
- 2) The spectrum analyzer was set to Maxpeak Detector function and Maximum hold mode.
- 3) The resolution bandwidth of the spectrum analyzer was comparable to the emission bandwidth.

Note:

None

Test Results:

GSM 850 band GSM mode

Channel No.	Maximum output power (PK) [dBm]			
	128 (824.2MHz)	30.4		
190 (836.6MHz)	30.4			
251 (848.8MHz)	30.5			

GSM 850 band GPRS mode

Channel No.	Maximum output power (PK) [dBm]			
	1TS	2TS	3TS	4TS
128 (824.2MHz)	30.3	29.4	27.4	27.0
190 (836.6MHz)	30.4	29.4	27.5	27.0
251 (848.8MHz)	30.5	29.5	27.6	27.0

GSM 850 band EGPRS(GMSK) mode

Channel No.	Maximum output power (PK) [dBm]			
	1TS	2TS	3TS	4TS
128 (824.2MHz)	30.4	29.4	27.4	27.0
190 (836.6MHz)	30.5	29.4	27.5	27.0
251 (848.8MHz)	30.5	29.5	27.6	27.0

GSM 850 band EGPRS(8PSK) mode

Channel No.	Maximum output power (PK) [dBm]			
	1TS	2TS	3TS	4TS
128 (824.2MHz)	28.5	27.6	25.5	25.0
190 (836.6MHz)	28.6	27.7	25.6	25.1
251 (848.8MHz)	28.6	27.8	25.6	25.1

GSM 1900 band GSM mode

Channel No.	Maximum output power (PK) [dBm]
512 (1850.2MHz)	27.9
661 (1880.0MHz)	27.7
810 (1909.8MHz)	27.4

GSM 1900 band GPRS mode

Channel No.	Maximum output power (PK) [dBm]			
	1TS	2TS	3TS	4TS
512 (1850.2MHz)	27.9	26.7	24.8	24.4
661 (1880.0MHz)	27.8	26.5	24.6	24.2
810 (1909.8MHz)	27.4	26.2	24.3	23.9

GSM 1900 band EGPRS(GMSK) mode

Channel No.	Maximum output power (PK) [dBm]			
	1TS	2TS	3TS	4TS
512 (1850.2MHz)	27.9	26.7	24.8	24.3
661 (1880.0MHz)	27.8	26.5	24.6	24.2
810 (1909.8MHz)	27.4	26.2	24.4	23.9

GSM 1900 band EGPRS(8PSK) mode

Channel No.	Maximum output power (PK) [dBm]			
	1TS	2TS	3TS	4TS
512 (1850.2MHz)	26.9	25.8	24.0	23.6
661 (1880.0MHz)	26.7	25.7	23.8	23.4
810 (1909.8MHz)	26.5	25.6	23.7	23.2

WCDMA V band mode

		Maximum output power (PK) [dBm]		
mode	3GPP Subtest	4132	4182	4233
RMC	--	22.36	22.42	22.25
HSDPA	1	21.61	21.51	21.38
	2	21.19	21.05	20.95
	3	19.59	19.45	19.35
	4	19.59	19.44	19.29
HSUPA (QPSK)	1	19.62	19.36	19.44
	2	19.64	19.48	19.35
	3	19.68	19.41	19.44
	4	19.64	19.47	19.41
	5	19.61	19.40	19.42
HSUPA (16QAM)	1	19.54	19.23	19.28
	2	19.52	19.38	19.25
	3	19.53	19.31	19.34
	4	19.49	19.33	19.31
	5	19.51	19.29	19.33

WCDMA II band mode

		Maximum output power (PK) [dBm]		
mode	3GPP Subtest	9262	9400	9538
RMC	--	22.48	22.41	22.29
HSDPA	1	21.50	21.24	21.17
	2	21.18	20.86	20.83
	3	19.61	19.29	19.27
	4	19.51	19.22	19.25
HSUPA (QPSK)	1	19.53	19.25	19.23
	2	19.32	19.05	19.11
	3	19.48	19.19	19.16
	4	19.37	19.14	19.13
	5	19.20	19.16	19.12
HSUPA (16QAM)	1	19.31	19.15	19.17
	2	19.27	19.07	19.07
	3	19.35	19.09	19.06
	4	19.26	19.11	19.10
	5	19.15	19.08	19.06

4.6 Conducted Spurious Emission

Specifications:	2.1051,22.917,24.238
Date of Tests	2015-02-07-2015-02-09
Test conditions:	Ambient Temperature:15°C-35°C Relative Humidity:30%-60% Air pressure: 86-106kPa
Operation Mode	TX on, channel 128, 190, 251 and 512, 661, 810 for GSM/GPRS/EGPRS mode, channel 4132, 4182, 4233 and 9262, 9400, 9538 for WCDMA/HSUPA/HSDPA mode.
Test Results:	Pass

Limit Level Construction:

According to Part 24.238 (a), i.e., Out of band emissions. The power of any emission outside of the authorized operating frequency ranges must be attenuated below the transmitting power (P) by a factor of at least $43 + 10 \log(P)$ dB, so the limit level is:
 $P(\text{dBm}) - (43 + 10 \log(P)) \text{ dB} = -13\text{dBm}$

Limits for Radiated spurious emissions(UE)

Frequency range	Limit Level /Resolution Bandwidth
30 MHz to 20000 MHz	-13dBm/1MHz

Test Setup:

During the test, the EUT was controlled via the Wireless Communications Test Set to ensure max power transmission and proper modulation and measured by spectrum analyzer.

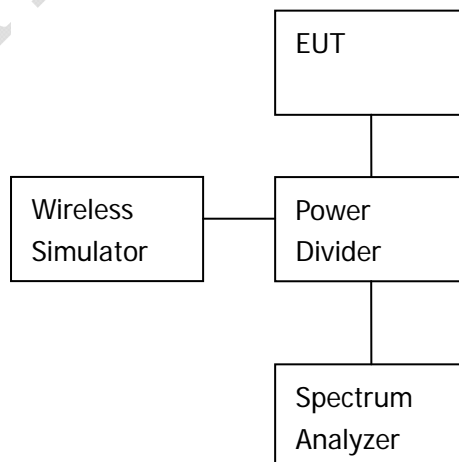

Test Method

The measurement was performed accordance with section 2.2.13 of ANSI/TIA-603-B-2002: *Land Mobile FM or PM Communications Equipment Measurement and Performance Standards*.

The following steps outline the procedure used to measure the conducted emissions from the EUT.

1. Determine frequency range for measurements: From CFR 2.1057 the spectrum should be investigated from the lowest radio frequency generated in the equipment up to at least the 10th harmonic of the carrier frequency.

Note:

None

Graphical results :

GMSK, Low channel, 824.200 MHz, 30MHz to 1GHz

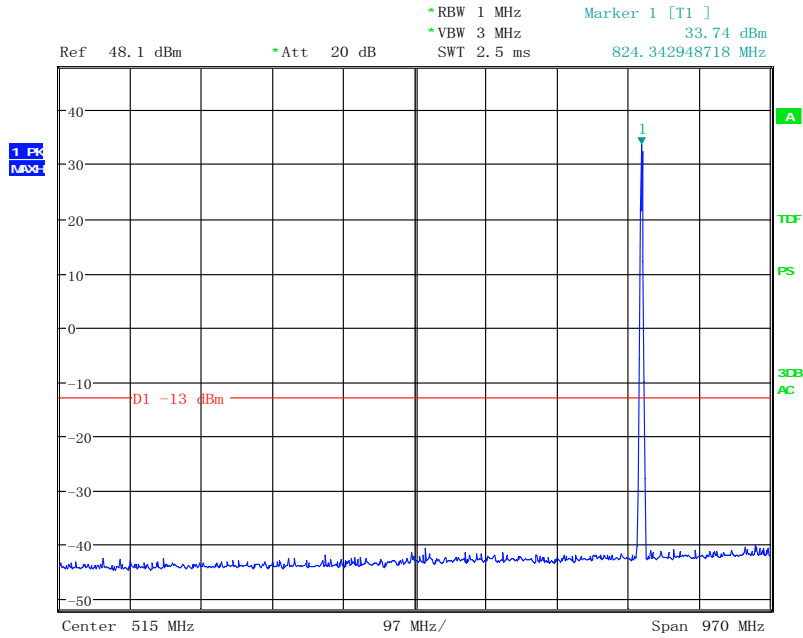

Date: 7. FEB. 2015 11:16:04

Note: The strong emission shown in each case is the carrier signal.

GMSK, Low channel, 824.200 MHz, 1GHz to 10GHz

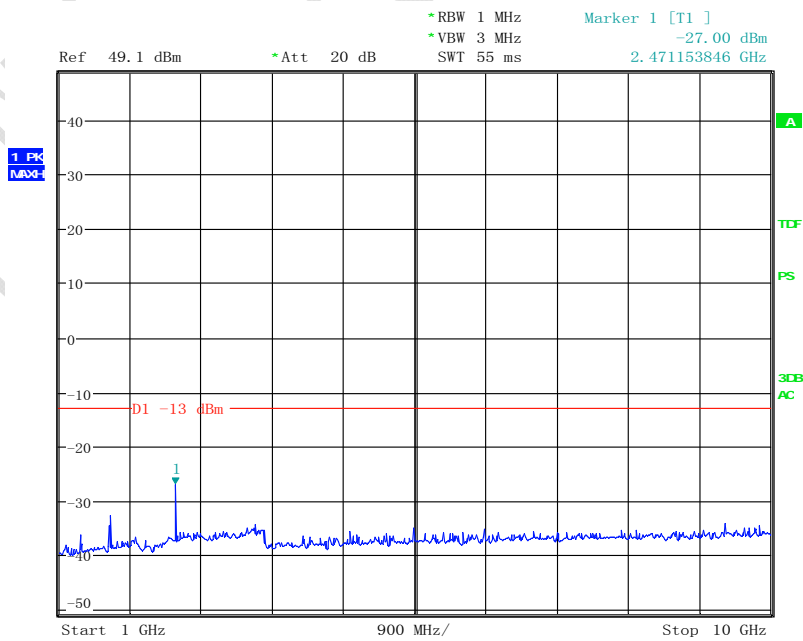

Date: 7. FEB. 2015 09:46:53

FCC Parts 2, 22, 24
Equipment: Ilium X400

REPORT NO.: B15X50050-FCC-RF_Rev2

GMSK, Low channel, 824.200 MHz, 10GHz to 20GHz

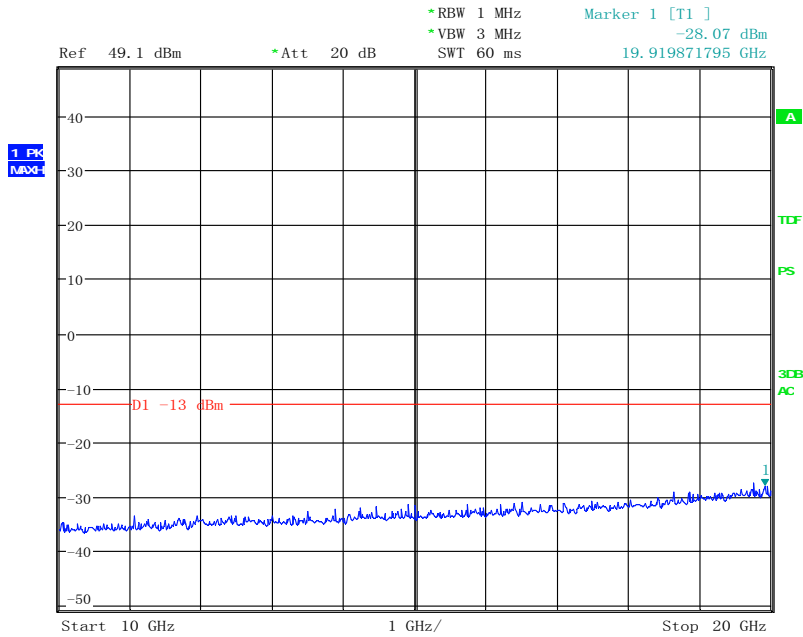

Date: 7.FEB.2015 09:47:09

GMSK, Mid Channel, 836.6 MHz, 30MHz to 1GHz

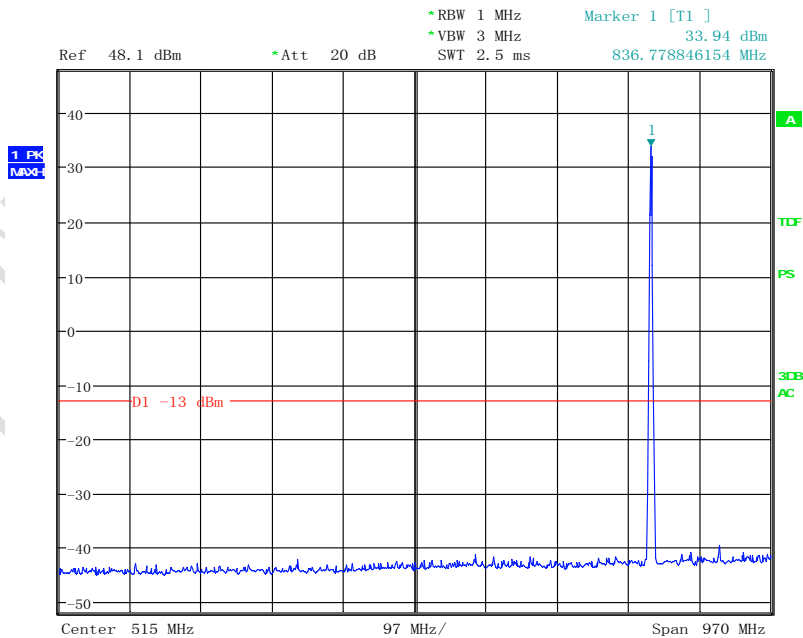

Date: 7.FEB.2015 11:16:19

Note: The strong emission shown in each case is the carrier signal.

FCC Parts 2, 22, 24
Equipment: Ilium X400

REPORT NO.: B15X50050-FCC-RF_Rev2

GMSK, Mid Channel, 836.6 MHz, 1GHz to 10GHz

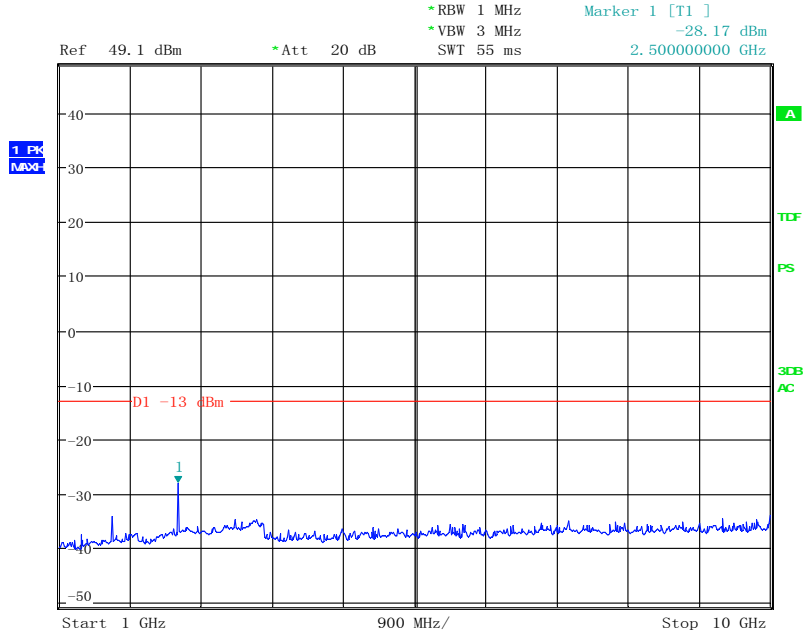

Date: 7.FEB.2015 09:49:24

GMSK, Mid Channel, 836.6 MHz, 10GHz to 20GHz

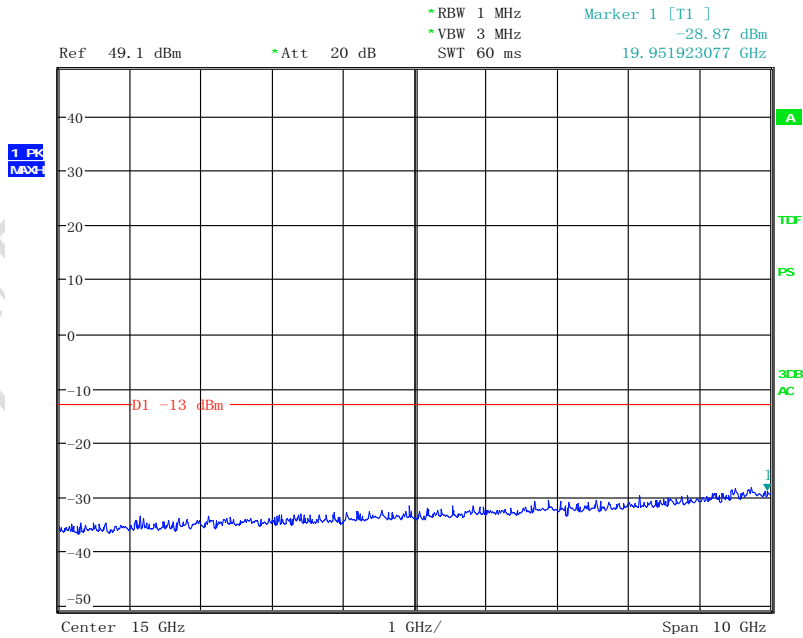

Date: 7.FEB.2015 09:49:40

FCC Parts 2, 22, 24
Equipment: Ilium X400

REPORT NO.: B15X50050-FCC-RF_Rev2

GMSK, High Channel, 848.8 MHz, 30MHz to 1GHz

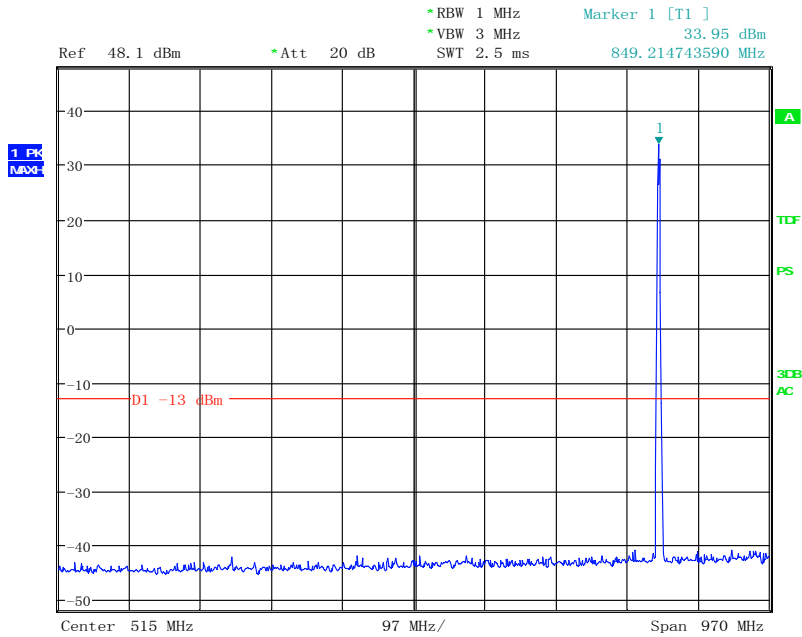

Date: 7.FEB.2015 11:16:34

Note: The strong emission shown in each case is the carrier signal.

GMSK, High Channel, 848.8 MHz, 1GHz to 10GHz

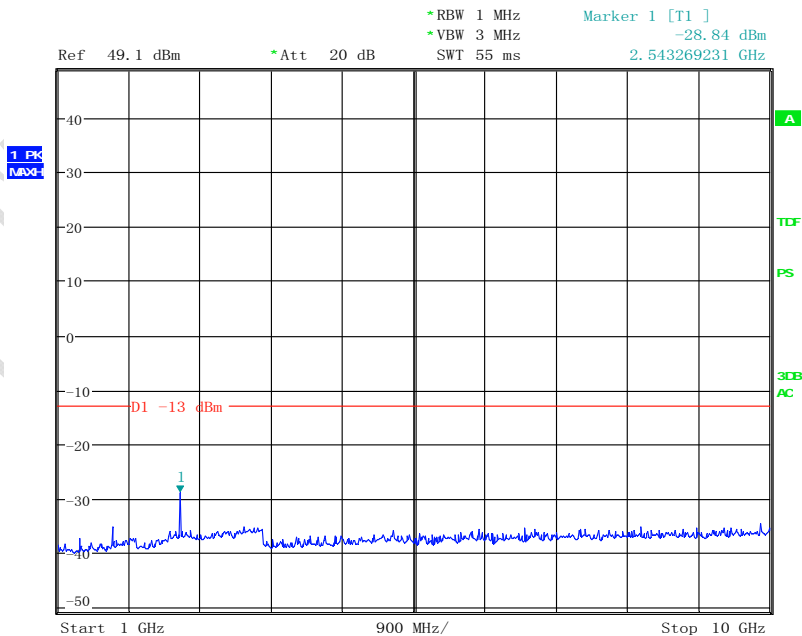

Date: 7.FEB.2015 09:50:33

FCC Parts 2, 22, 24
Equipment: Ilium X400

REPORT NO.: B15X50050-FCC-RF_Rev2

GMSK, High Channel, 848.8 MHz, 10GHz to 20GHz

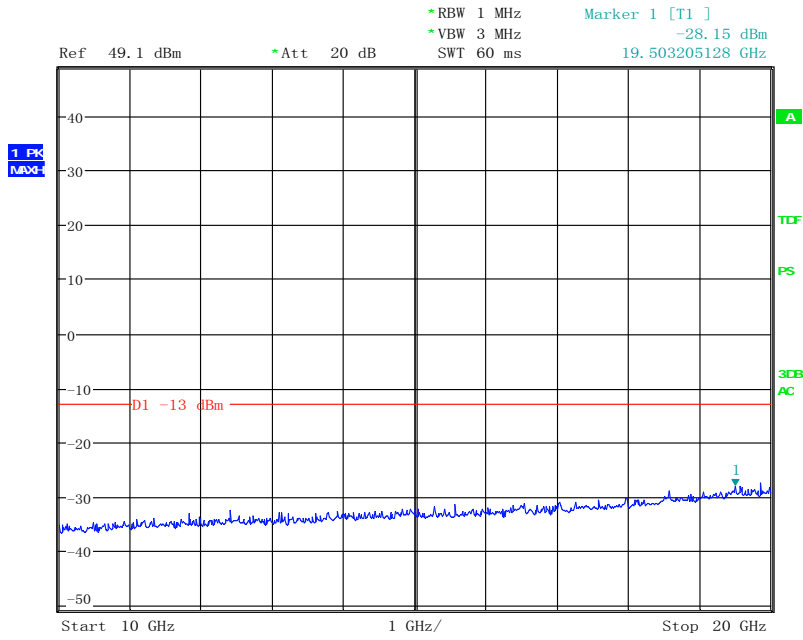

Date: 7.FEB.2015 09:50:54

8PSK, Low channel, 824.200 MHz, 30MHz to 1GHz

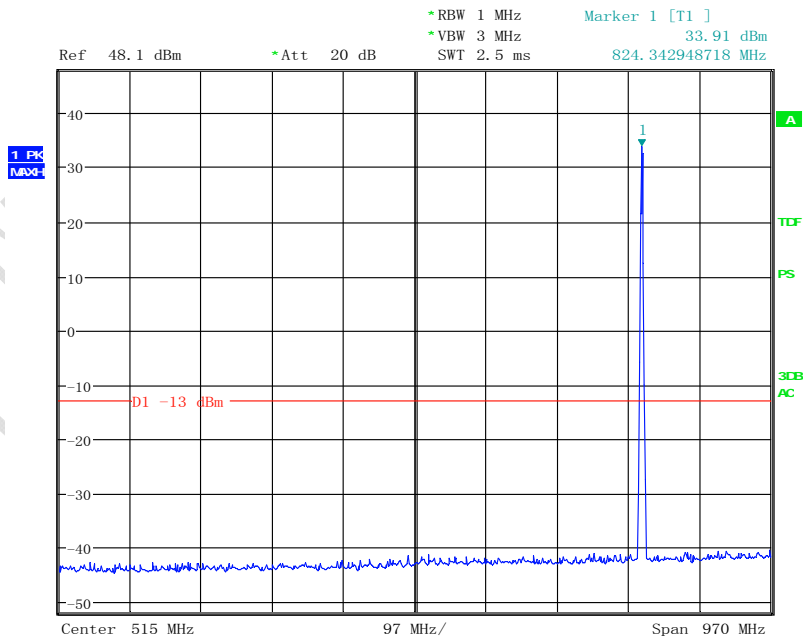

Date: 7.FEB.2015 11:13:13

Note: The strong emission shown in each case is the carrier signal.

FCC Parts 2, 22, 24
Equipment: Ilium X400

REPORT NO.: B15X50050-FCC-RF_Rev2

8PSK, Low channel, 824.200 MHz, 1GHz to 10GHz

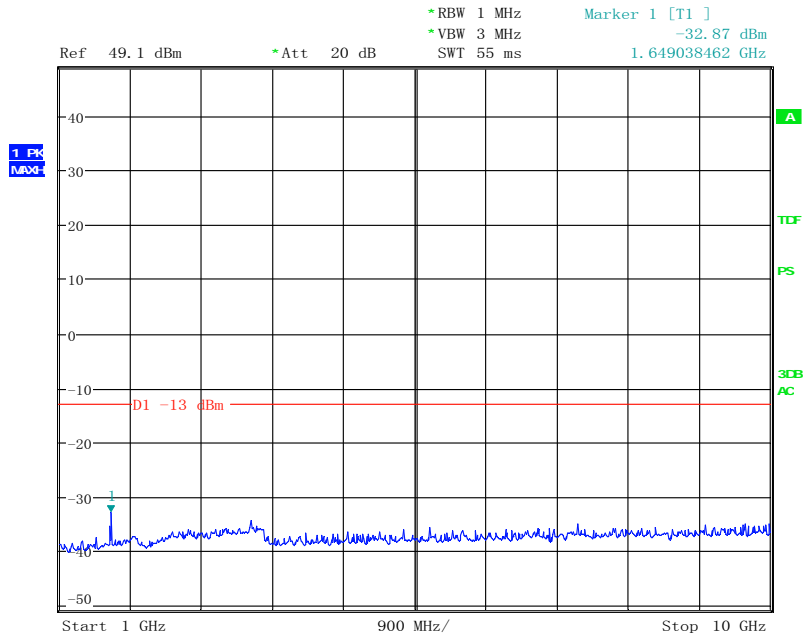

Date: 7. FEB. 2015 09:52:23

8PSK, Low channel, 824.200 MHz, 10GHz to 20GHz

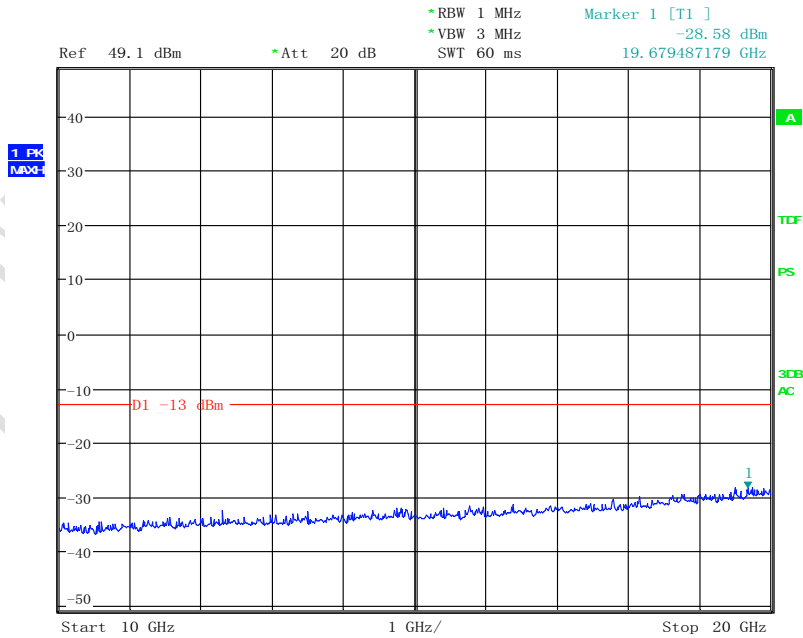

Date: 7. FEB. 2015 09:52:45

FCC Parts 2, 22, 24
Equipment: Ilium X400

REPORT NO.: B15X50050-FCC-RF_Rev2

8PSK, Mid Channel, 836.6 MHz, 30MHz to 1GHz

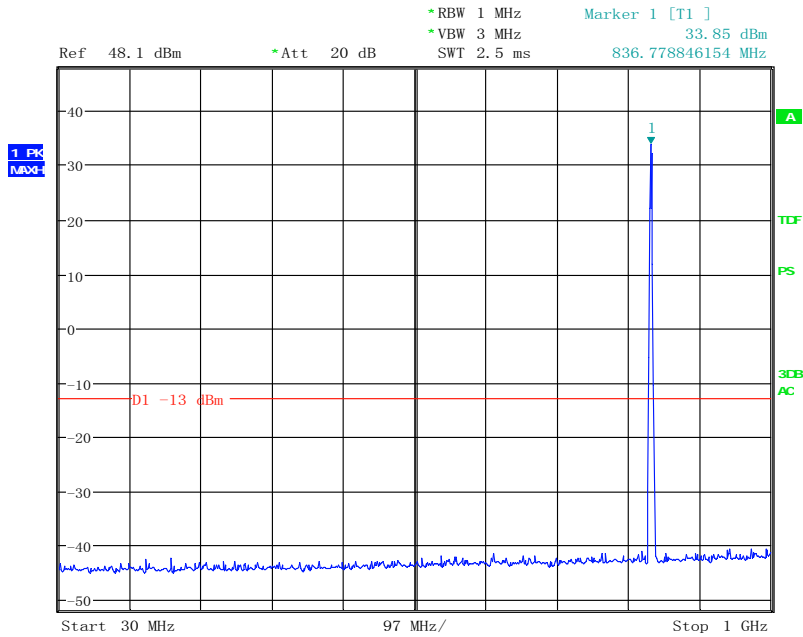

Date: 7.FEB.2015 11:14:21

Note: The strong emission shown in each case is the carrier signal.

8PSK, Mid Channel, 836.6 MHz, 1GHz to 10GHz

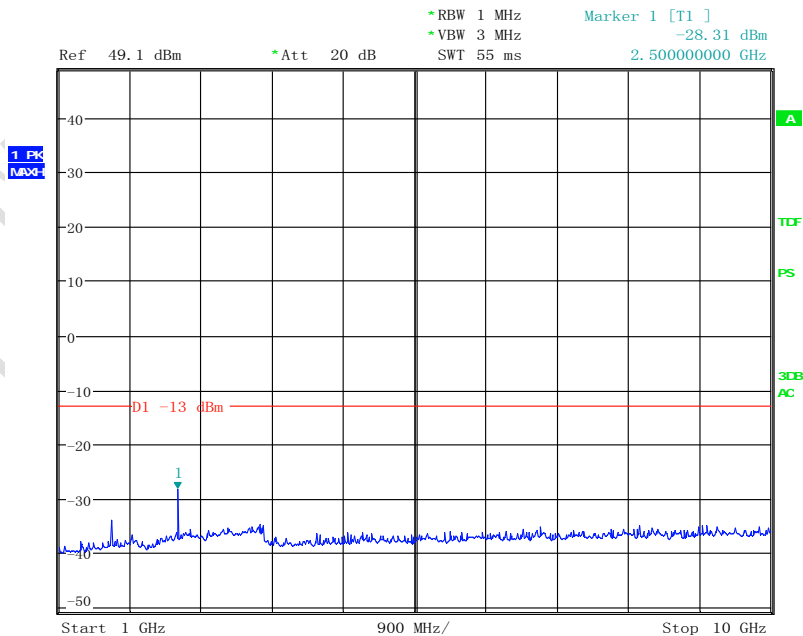

Date: 7.FEB.2015 09:53:41

FCC Parts 2, 22, 24
Equipment: Ilium X400

REPORT NO.: B15X50050-FCC-RF_Rev2

8PSK, Mid Channel, 836.6 MHz, 10GHz to 20GHz

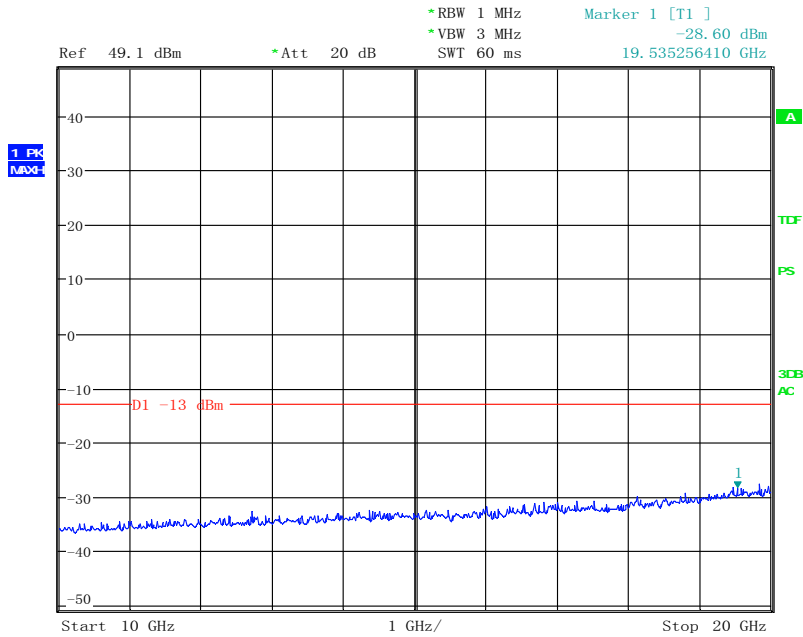

Date: 7.FEB.2015 09:53:55

8PSK, High Channel, 848.8 MHz, 30MHz to 1GHz

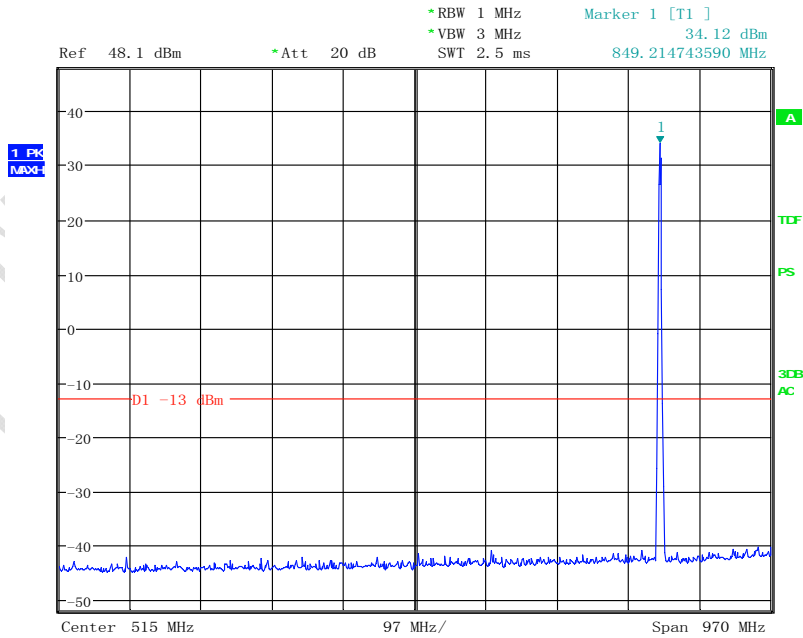

Date: 7.FEB.2015 11:14:43

Note: The strong emission shown in each case is the carrier signal.

FCC Parts 2, 22, 24
Equipment: Ilium X400

REPORT NO.: B15X50050-FCC-RF_Rev2

8PSK, High Channel, 848.8 MHz, 1GHz to 10GHz

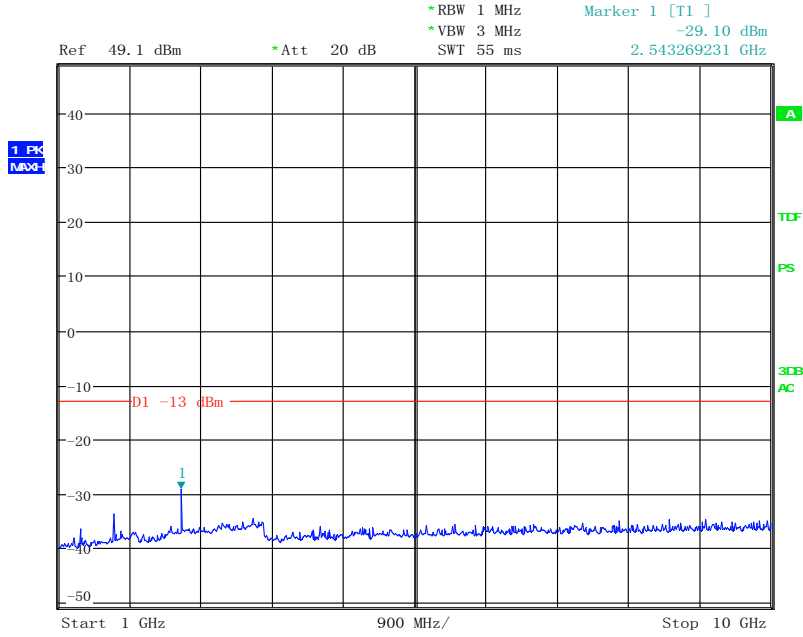

Date: 7.FEB.2015 09:54:54

8PSK, High Channel, 848.8 MHz, 10GHz to 20GHz

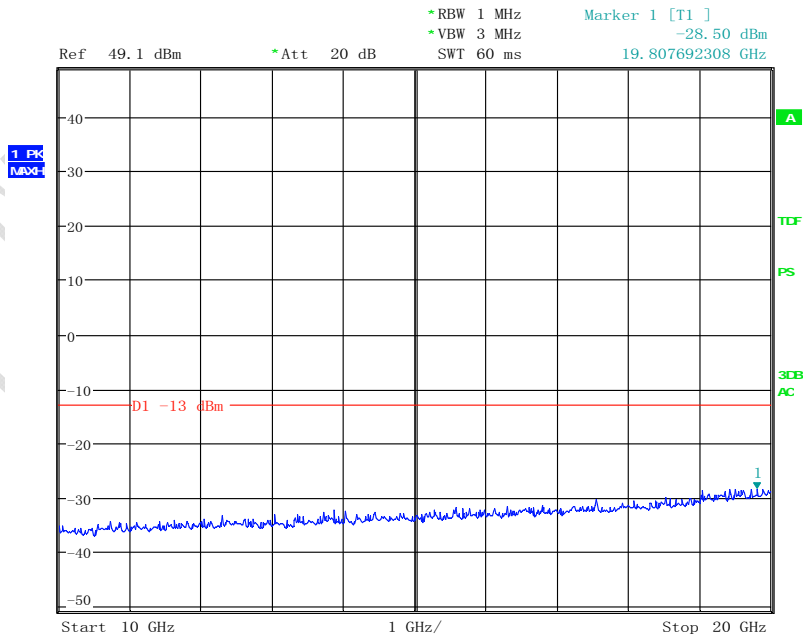

Date: 7.FEB.2015 09:55:08

FCC Parts 2, 22, 24
Equipment: Ilium X400

REPORT NO.: B15X50050-FCC-RF_Rev2

GMSK, Low channel, 1850.2 MHz, 30MHz to 1GHz

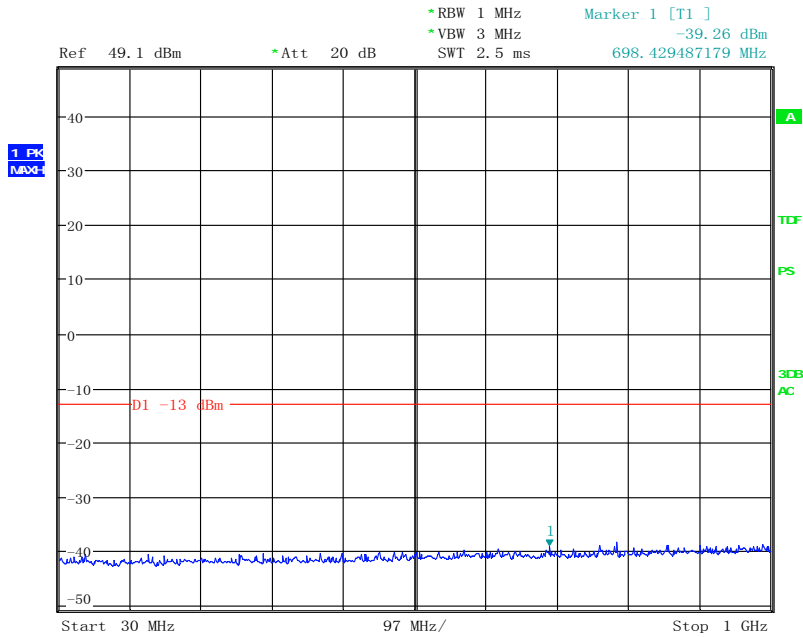

Date: 7.FEB.2015 09:41:40

GMSK, Low channel, 1850.2 MHz, 1GHz to 10GHz

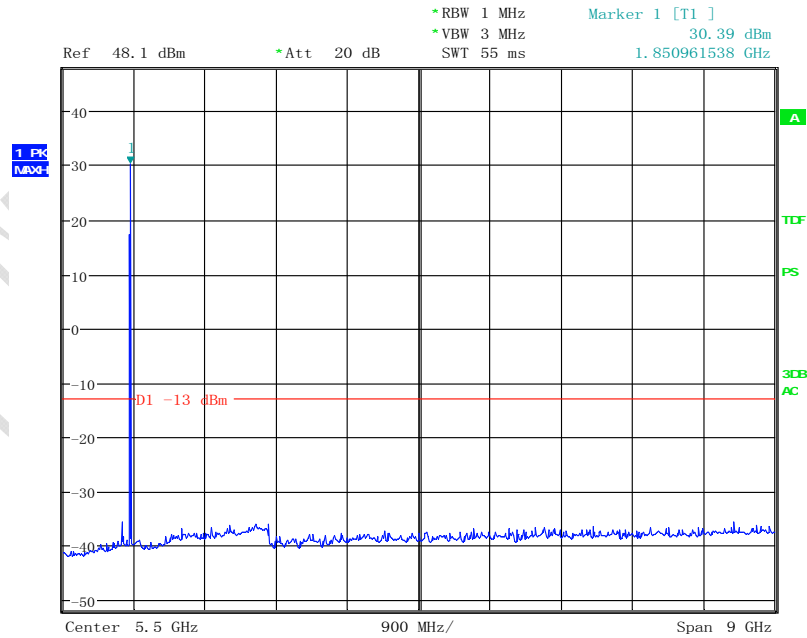

Date: 7.FEB.2015 11:41:28

Note: The strong emission shown is the carrier signal.

FCC Parts 2, 22, 24
Equipment: Ilium X400

REPORT NO.: B15X50050-FCC-RF_Rev2

GMSK, Low channel, 1850.2 MHz, 10GHz to 20GHz

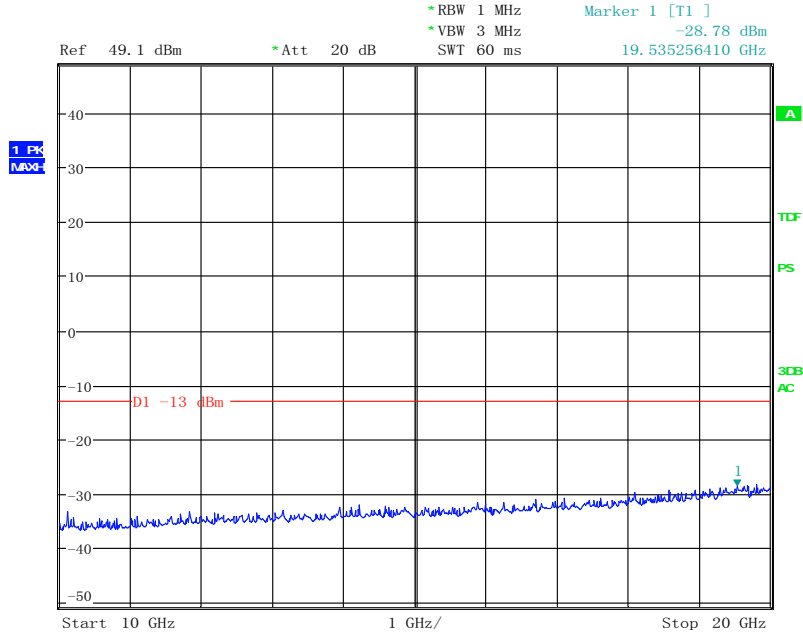

Date: 7.FEB.2015 09:42:20

GMSK, Middle channel, 1880.0 MHz, 30MHz to 1GHz

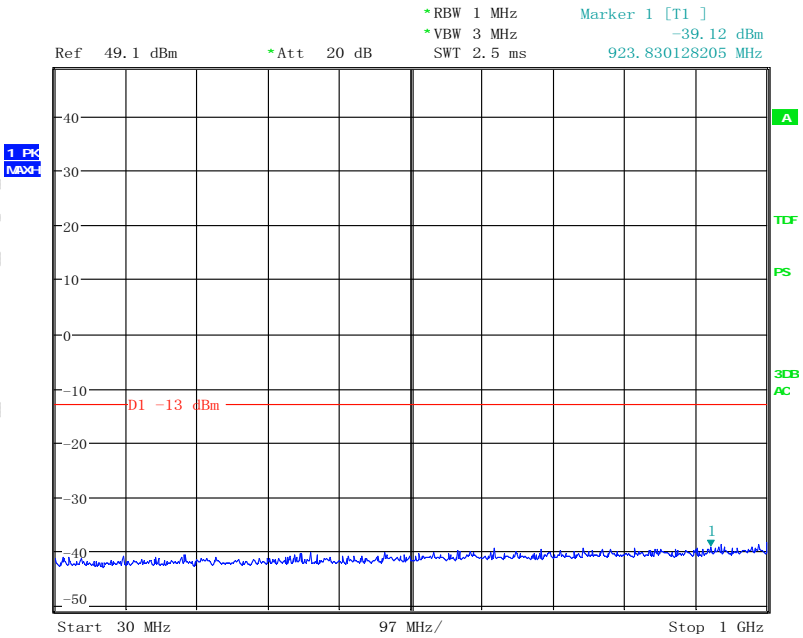

Date: 7.FEB.2015 09:42:47

FCC Parts 2, 22, 24
Equipment: Ilium X400

REPORT NO.: B15X50050-FCC-RF_Rev2

GMSK, Middle channel, 1880.0 MHz, 1GHz to 10GHz

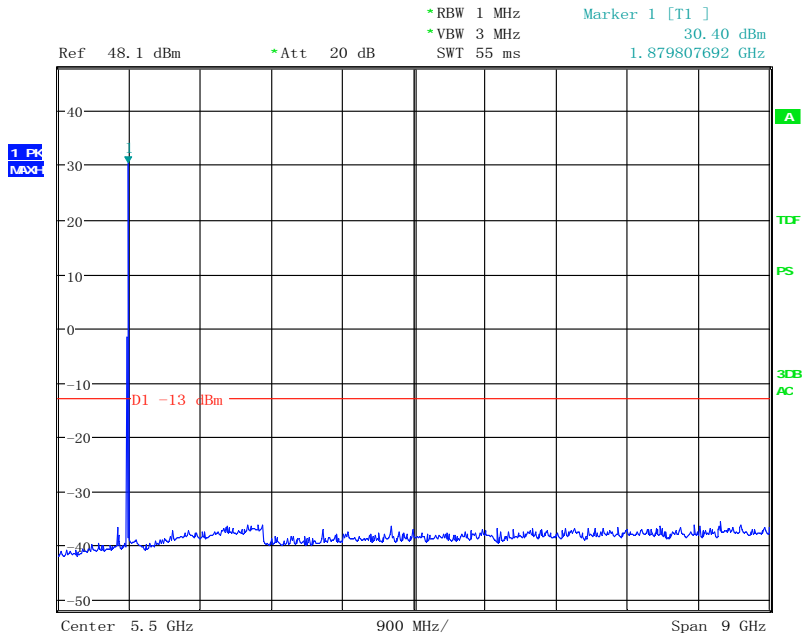

Date: 7. FEB. 2015 11:41:53

Note: The strong emission shown is the carrier signal.

GMSK, Middle channel, 1880.0 MHz, 10GHz to 20GHz

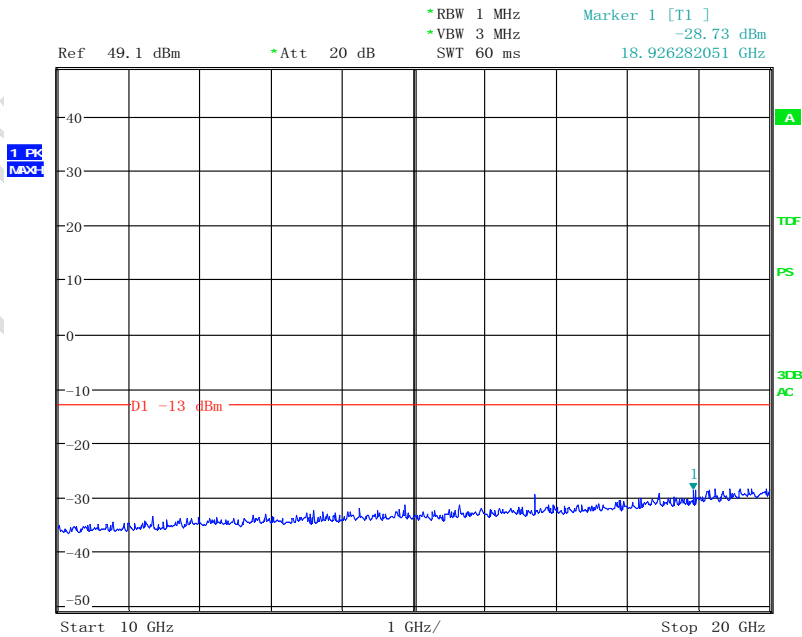

Date: 7. FEB. 2015 09:43:33

FCC Parts 2, 22, 24
Equipment: Ilium X400

REPORT NO.: B15X50050-FCC-RF_Rev2

GMSK, High channel, 1909.8 MHz, 30MHz to 1GHz

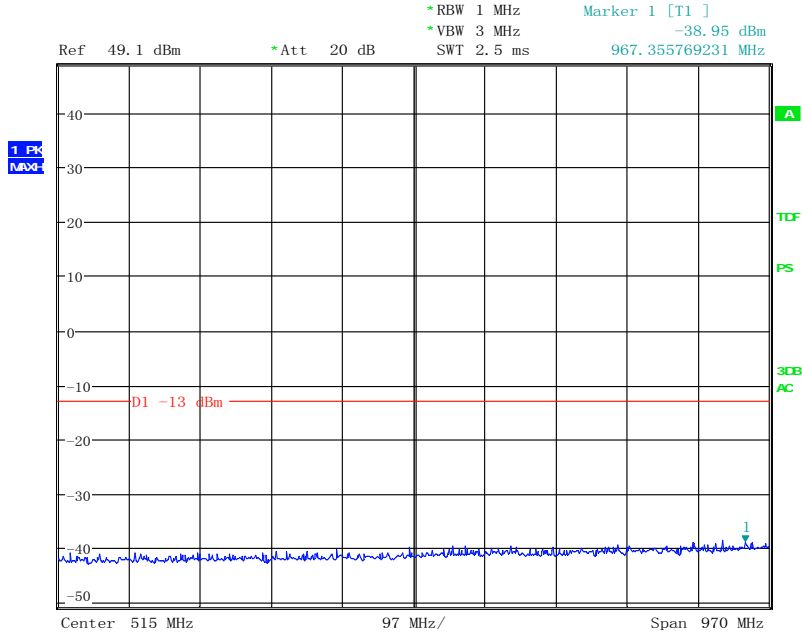

Date: 7.FEB.2015 09:44:02

GMSK, High channel, 1909.8 MHz, 1GHz to 10GHz

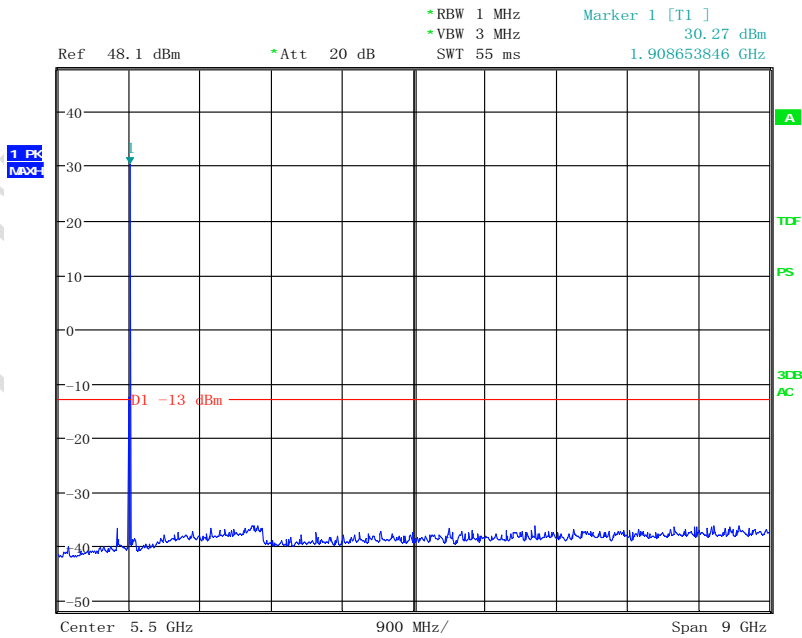

Date: 7.FEB.2015 11:42:11

Note: The strong emission shown is the carrier signal.

FCC Parts 2, 22, 24
Equipment: Ilium X400

REPORT NO.: B15X50050-FCC-RF_Rev2

GMSK, High channel, 1909.8 MHz, 10GHz to 20GHz

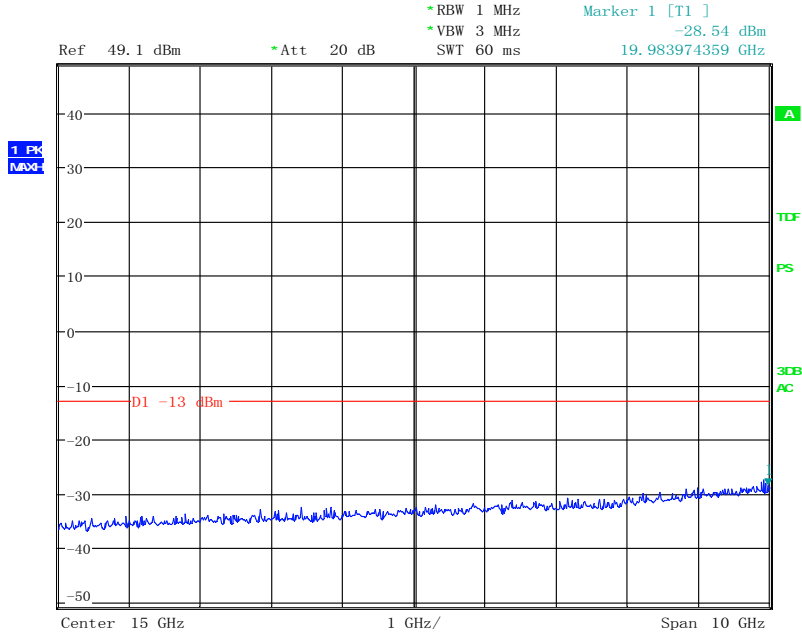

Date: 7.FEB.2015 09:44:45

8PSK, Low channel, 1850.2 MHz, 30MHz to 1GHz

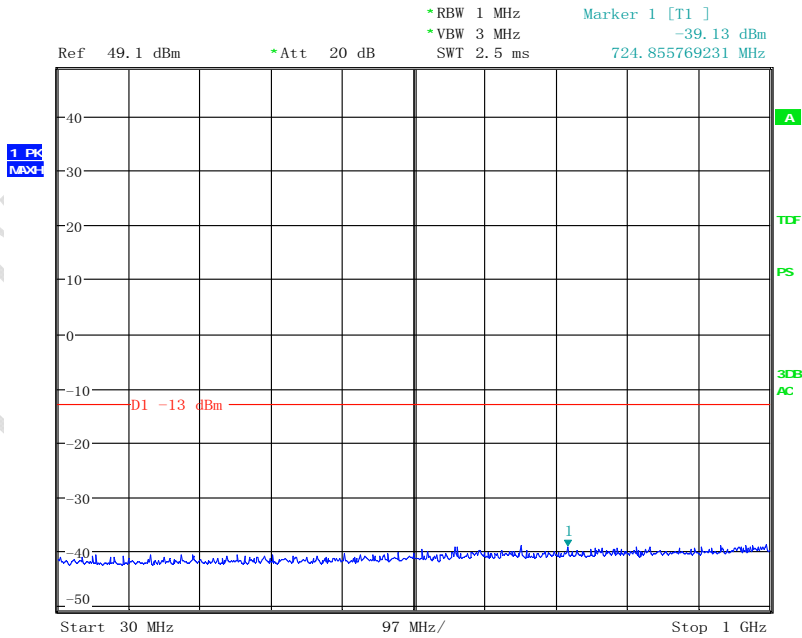

Date: 7.FEB.2015 09:33:55

FCC Parts 2, 22, 24
Equipment: Ilium X400

REPORT NO.: B15X50050-FCC-RF_Rev2

8PSK, Low channel, 1850.2 MHz, 1GHz to 10GHz

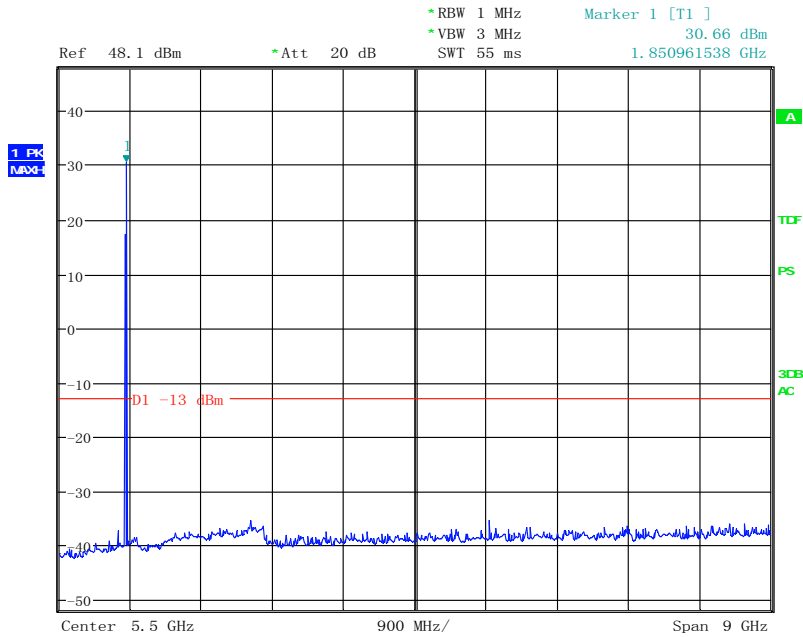

Date: 7.FEB.2015 11:40:39

Note: The strong emission shown is the carrier signal.

8PSK, Low channel, 1850.2 MHz, 10GHz to 20GHz

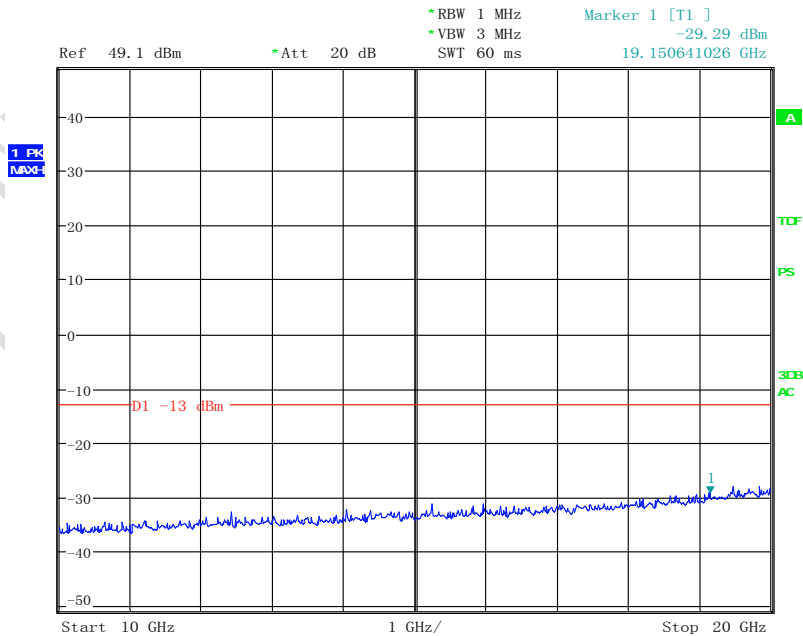

Date: 7.FEB.2015 09:34:58

8PSK, Middle channel, 1880.0 MHz, 30MHz to 1GHz

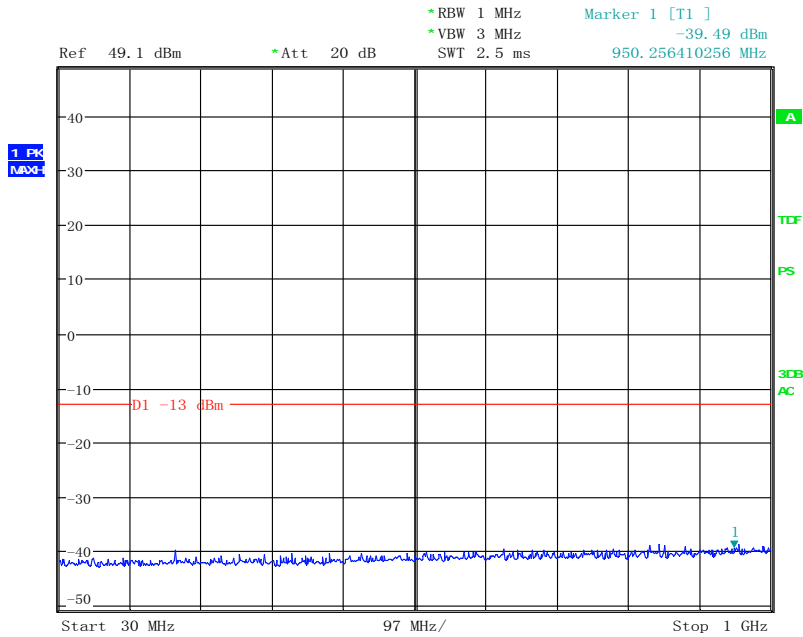

Date: 7.FEB.2015 09:39:52

8PSK, Middle channel, 1880.0 MHz, 1GHz to 10GHz

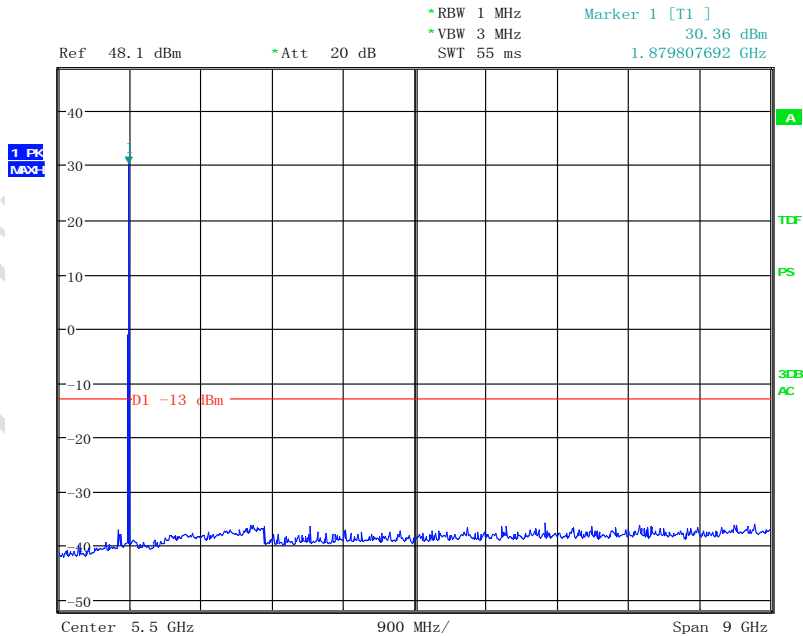

Date: 7.FEB.2015 11:40:22

Note: The strong emission shown is the carrier signal.

FCC Parts 2, 22, 24
Equipment: Ilium X400

REPORT NO.: B15X50050-FCC-RF_Rev2

8PSK, Middle channel, 1880.0 MHz, 10GHz to 20GHz

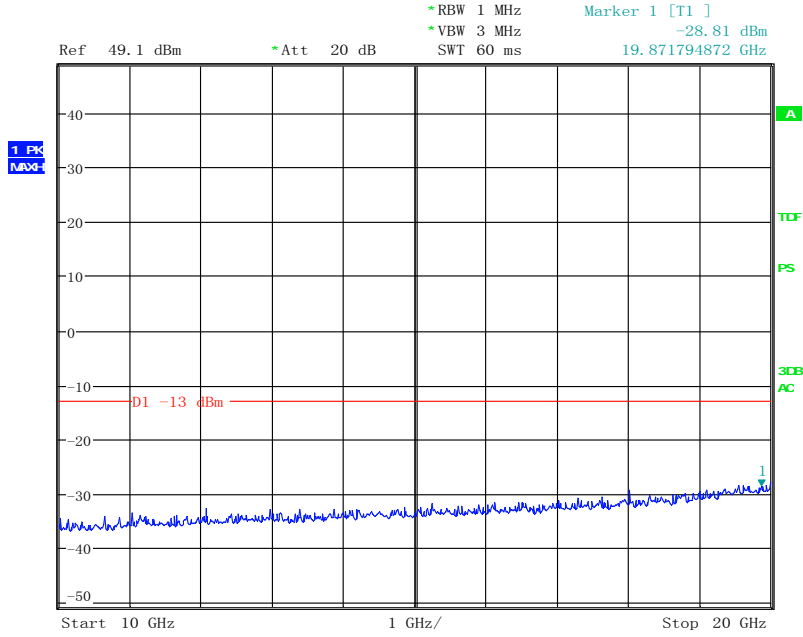

Date: 7.FEB.2015 09:40:32

8PSK, High channel, 1909.8 MHz, 30MHz to 1GHz

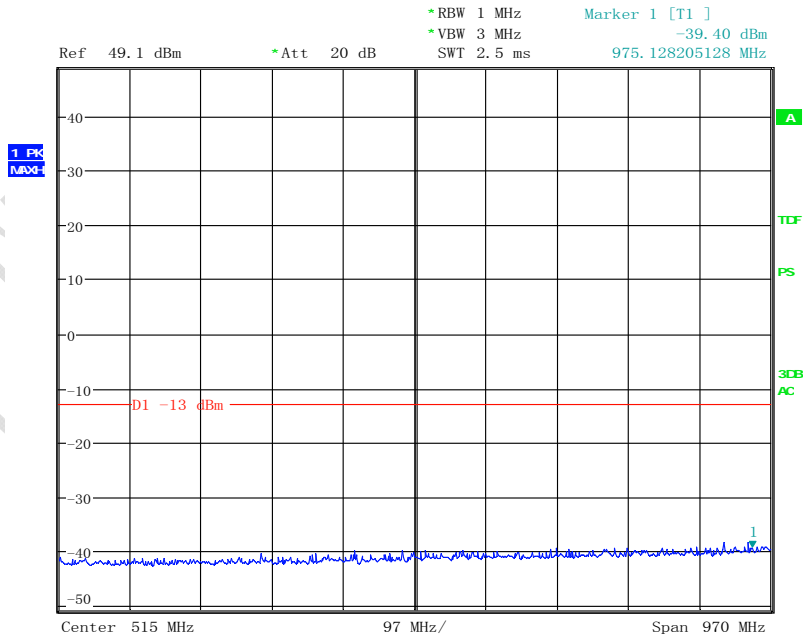

Date: 7.FEB.2015 09:38:44

FCC Parts 2, 22, 24
Equipment: Ilium X400

REPORT NO.: B15X50050-FCC-RF_Rev2

8PSK, High channel, 1909.8 MHz, 1GHz to 10GHz

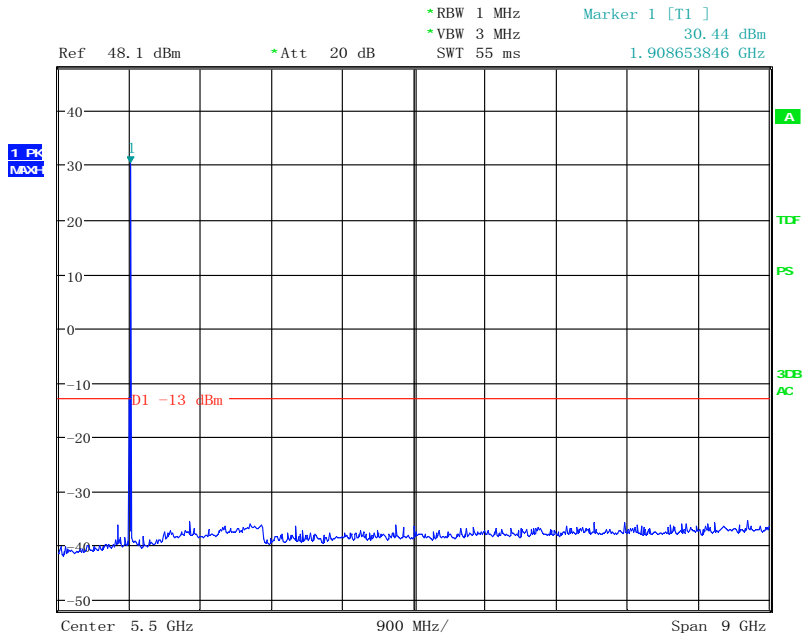

Date: 7. FEB. 2015 11:39:58

Note: The strong emission shown is the carrier signal

8PSK, High channel, 1909.8 MHz, 10GHz to 20GHz

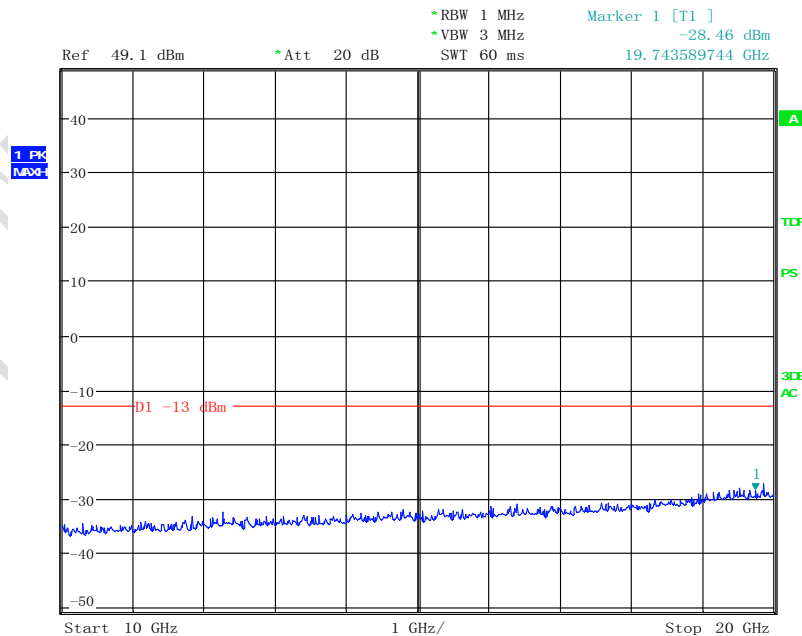

Date: 7. FEB. 2015 09:39:23

FCC Parts 2, 22, 24
Equipment: Ilium X400

REPORT NO.: B15X50050-FCC-RF_Rev2

QPSK, Low channel, 826.4 MHz, 30MHz to 1GHz

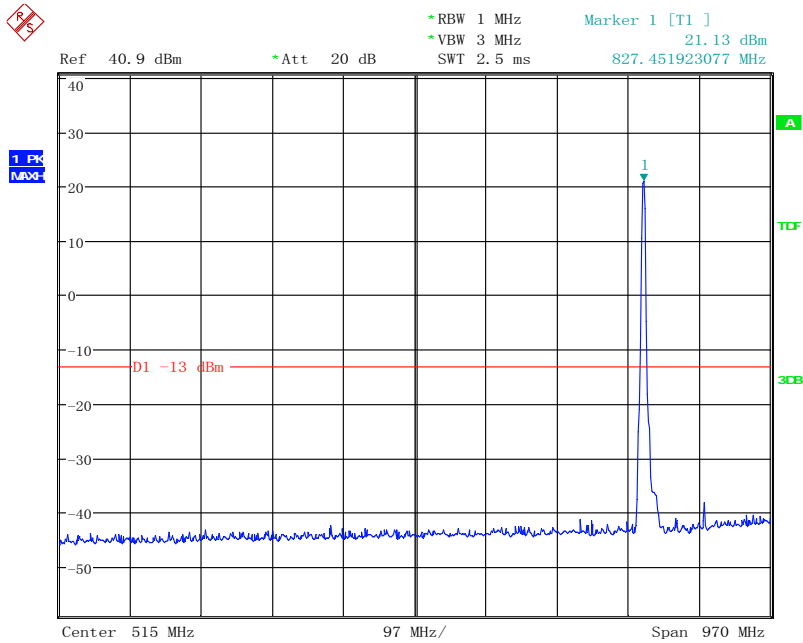

Date: 9. FEB. 2015 11:06:21

Note: The strong emission shown in each case is the carrier signal.

QPSK, Low channel, 826.4 MHz, 1GHz to 10GHz

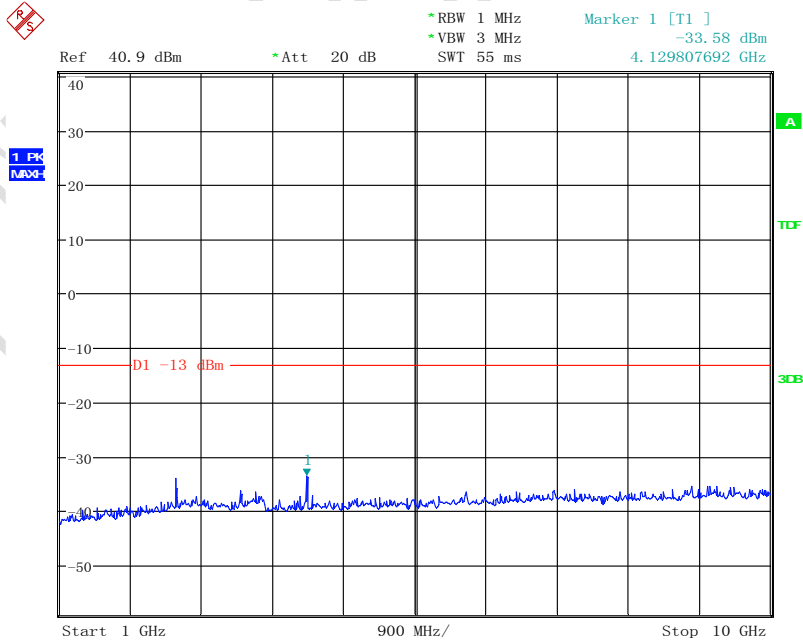

Date: 9. FEB. 2015 11:06:43

FCC Parts 2, 22, 24
Equipment: Ilium X400

REPORT NO.: B15X50050-FCC-RF_Rev2

QPSK, Low channel, 826.4 MHz, 10GHz to 20GHz

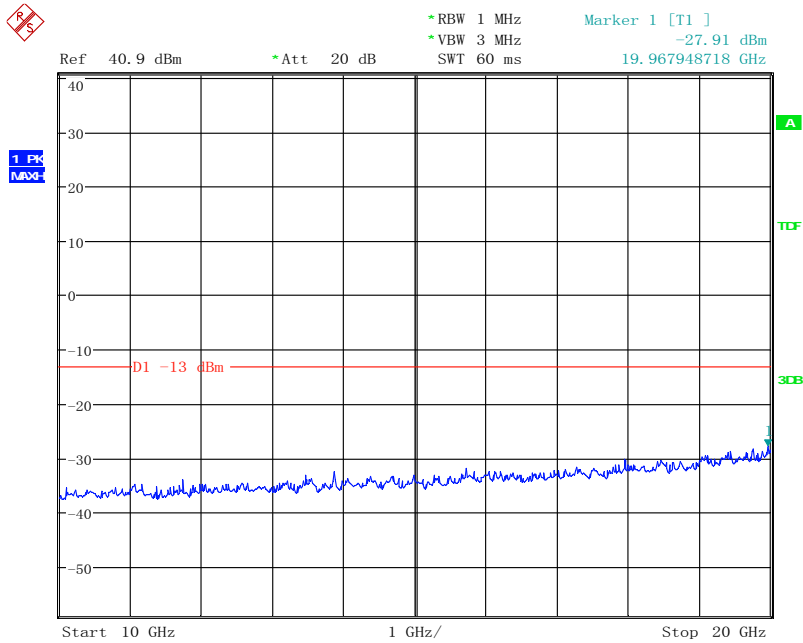

Date: 9. FEB. 2015 11:06:59

QPSK, Middle channel, 836.4 MHz, 30MHz to 1GHz

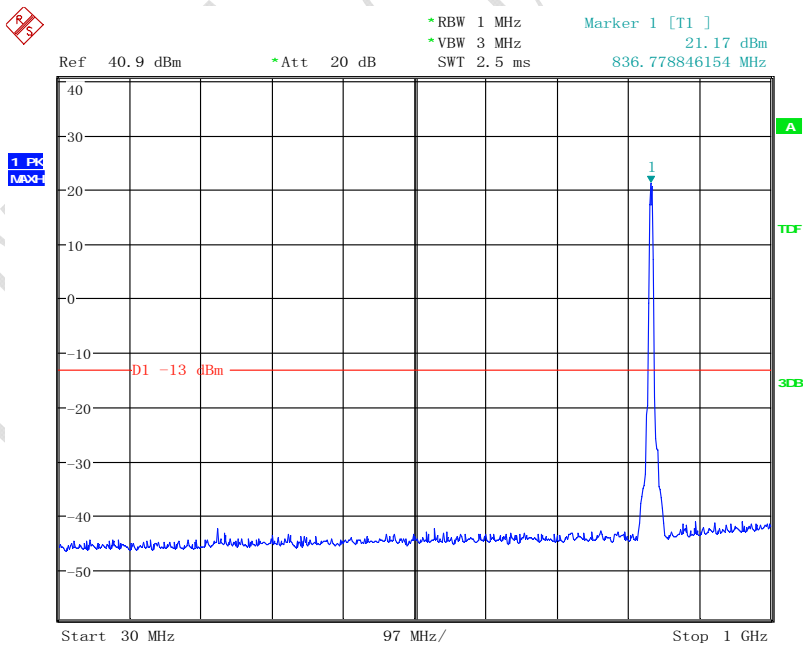

Date: 9. FEB. 2015 11:07:35

Note: The strong emission shown in each case is the carrier signal.

FCC Parts 2, 22, 24
Equipment: Ilium X400

REPORT NO.: B15X50050-FCC-RF_Rev2

QPSK, Middle channel, 836.4 MHz, 1GHz to 10GHz

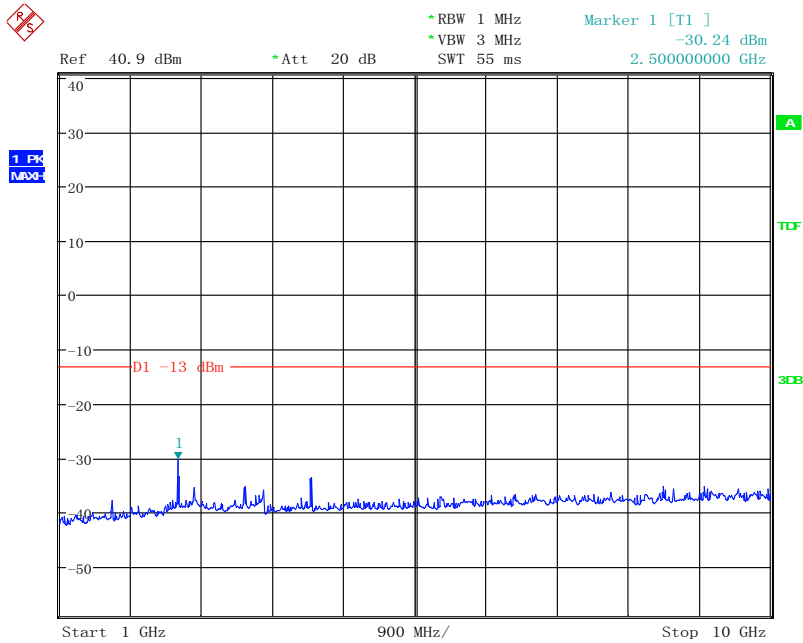

Date: 9.FEB.2015 11:07:52

QPSK, Middle channel, 836.4 MHz, 10GHz to 20GHz

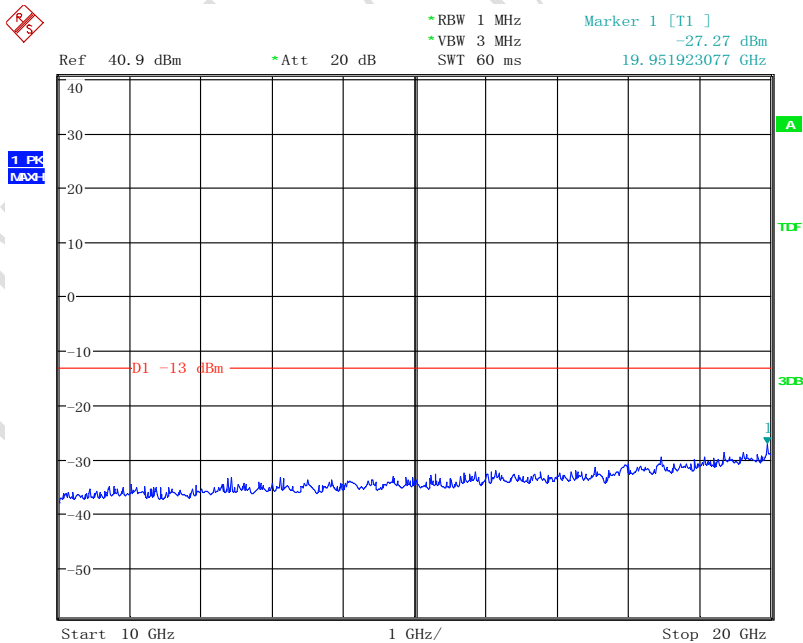

Date: 9.FEB.2015 11:08:07

FCC Parts 2, 22, 24
Equipment: Ilium X400

REPORT NO.: B15X50050-FCC-RF_Rev2

QPSK, High Channel, 846.6 MHz, 30MHz to 1GHz

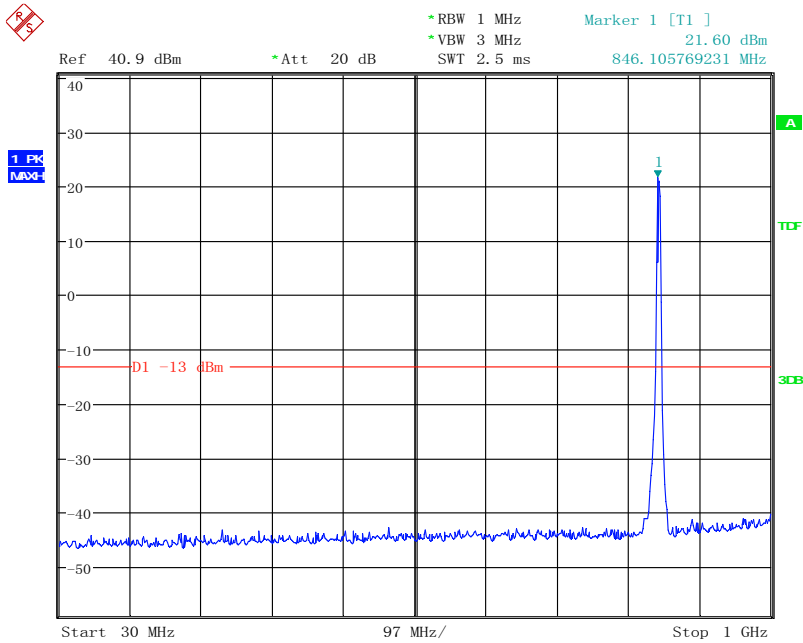

Date: 9.FEB.2015 11:08:33

Note: The strong emission shown in each case is the carrier signal.

QPSK, High Channel, 846.6 MHz, 1GHz to 10GHz

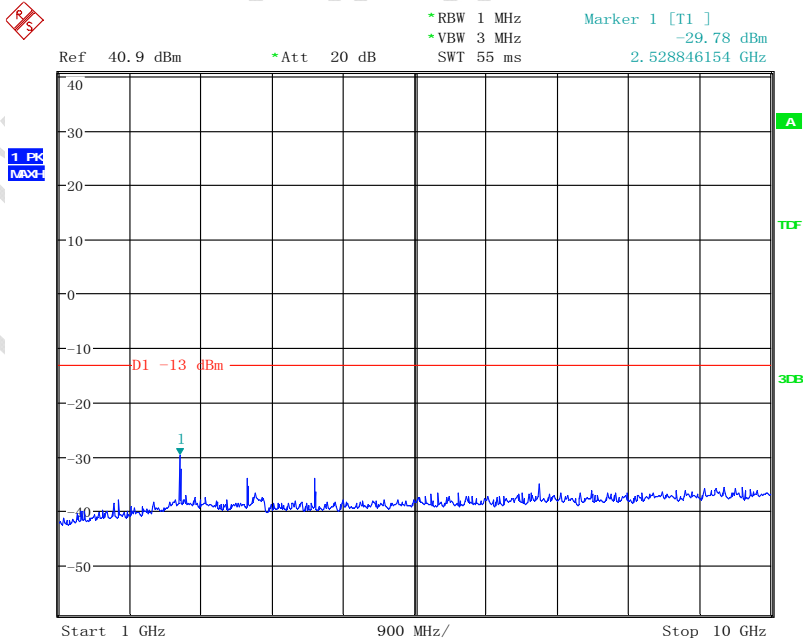

Date: 9.FEB.2015 11:08:50

FCC Parts 2, 22, 24
Equipment: Ilium X400

REPORT NO.: B15X50050-FCC-RF_Rev2

QPSK, High Channel, 846.6 MHz, 10GHz to 20GHz

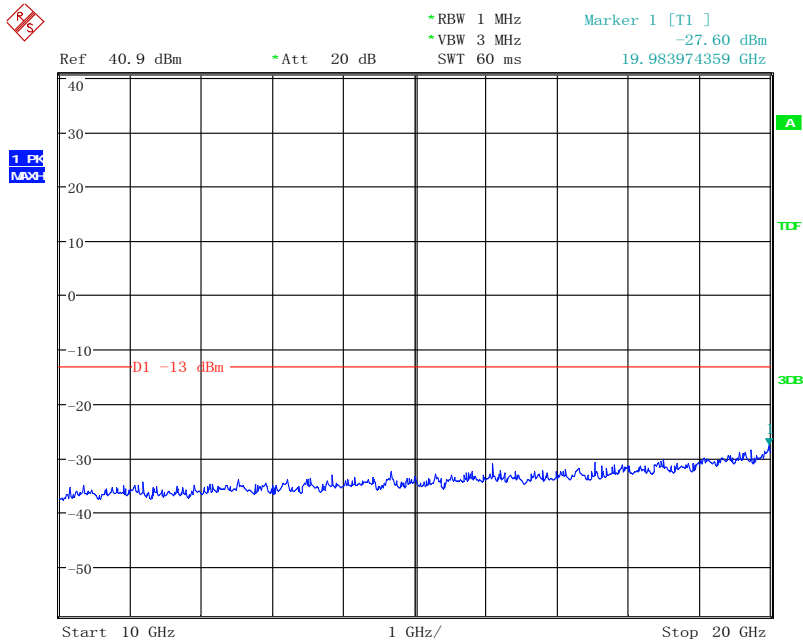

Date: 9.FEB.2015 11:09:04

QPSK, Low channel, 1852.4 MHz, 30MHz to 1GHz

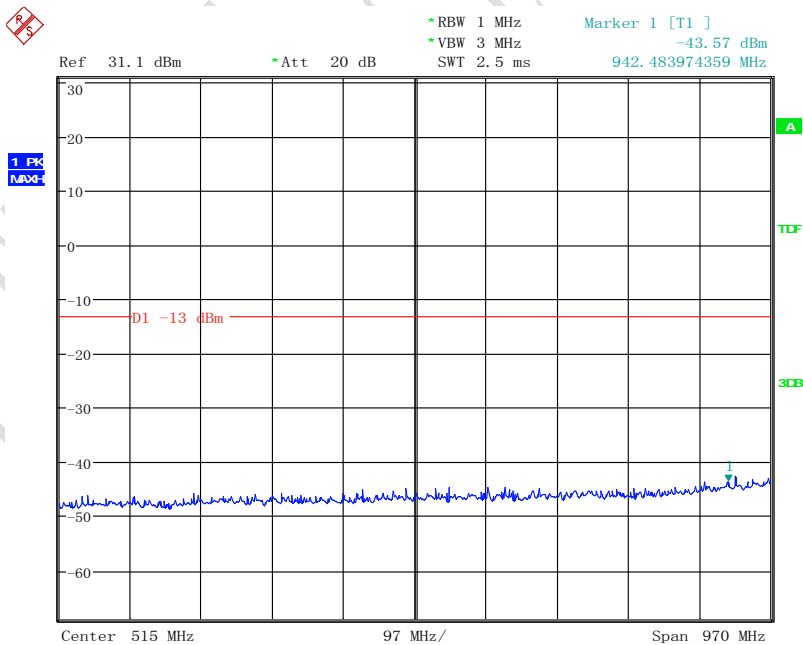

Date: 9.FEB.2015 08:25:58

FCC Parts 2, 22, 24
Equipment: Ilium X400

REPORT NO.: B15X50050-FCC-RF_Rev2

QPSK, Low channel, 1852.4 MHz, 1GHz to 10GHz

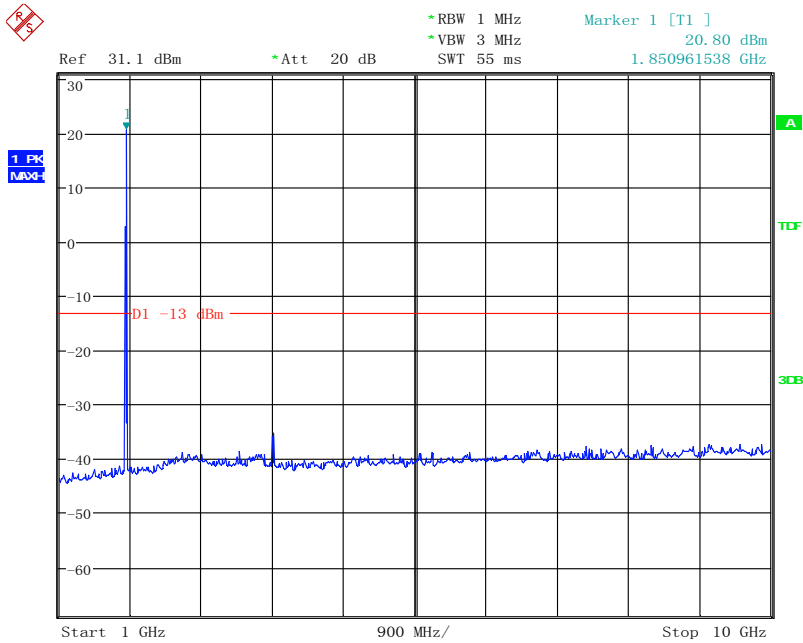

Date: 9.FEB.2015 08:26:36

Note: The strong emission shown is the carrier signal.

QPSK, Low channel, 1852.4 MHz, 10GHz to 20GHz

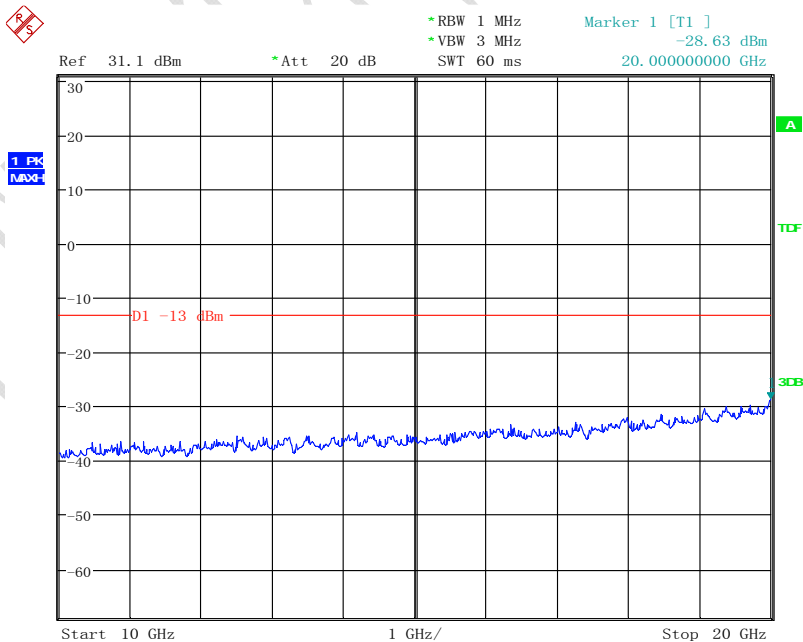

Date: 9.FEB.2015 08:26:59

FCC Parts 2, 22, 24
Equipment: Ilium X400

REPORT NO.: B15X50050-FCC-RF_Rev2

QPSK, Middle channel, 1880 MHz, 30MHz to 1GHz

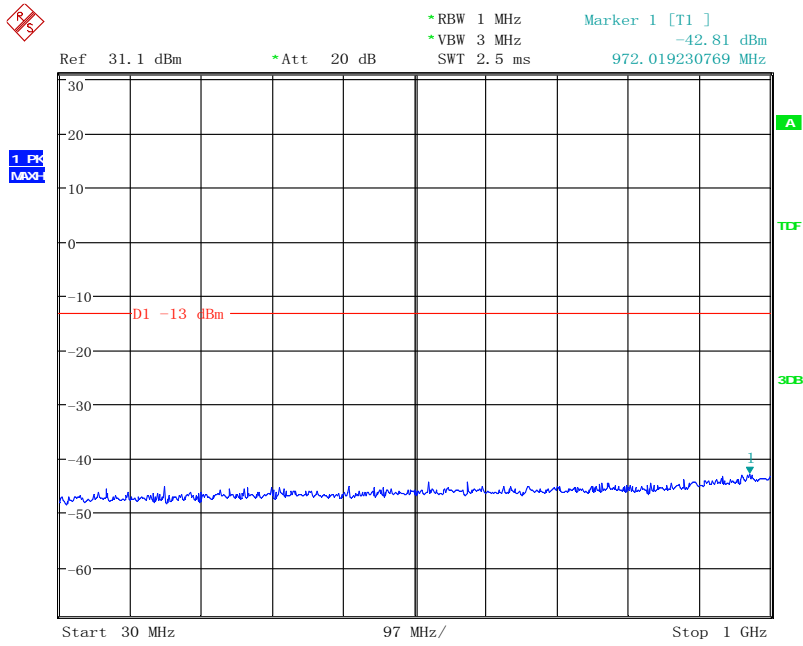

Date: 9.FEB.2015 08:29:50

QPSK, Middle channel, 1880 MHz, 1GHz to 10GHz

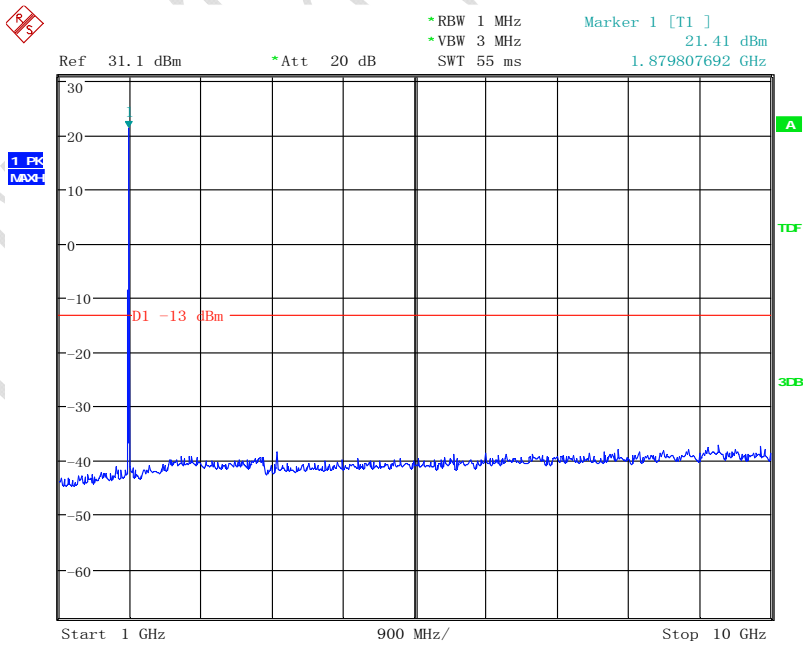

Date: 9.FEB.2015 08:30:13

Note: The strong emission shown is the carrier signal.

FCC Parts 2, 22, 24
Equipment: Ilium X400

REPORT NO.: B15X50050-FCC-RF_Rev2

QPSK, Middle channel, 1880 MHz, 10GHz to 20GHz

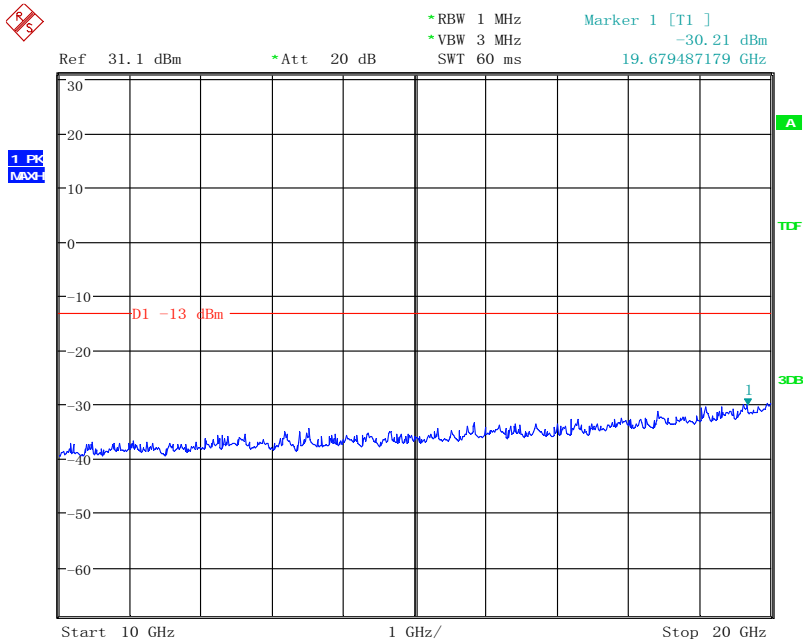

Date: 9.FEB.2015 08:30:30

QPSK, High channel, 1907.6 MHz, 30MHz to 1GHz

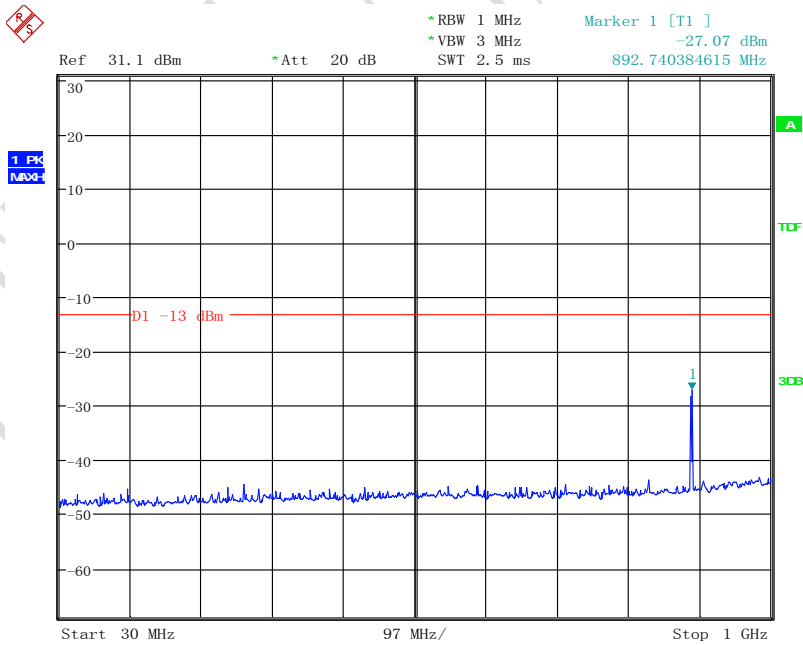

Date: 9.FEB.2015 08:31:33

QPSK, High channel, 1907.6 MHz, 1GHz to 10GHz

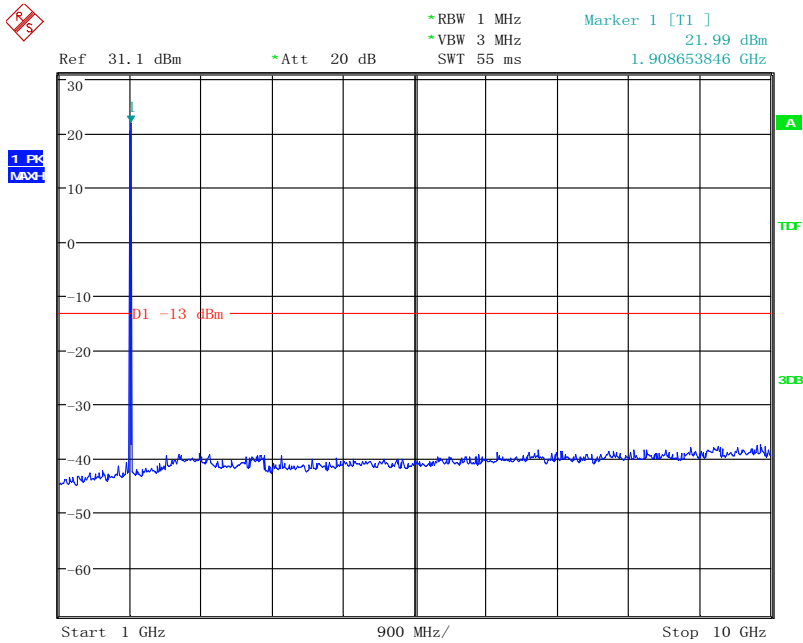

Date: 9.FEB.2015 08:32:13

Note: The strong emission shown is the carrier signal.

QPSK, High channel, 1907.6 MHz, 10GHz to 20GHz

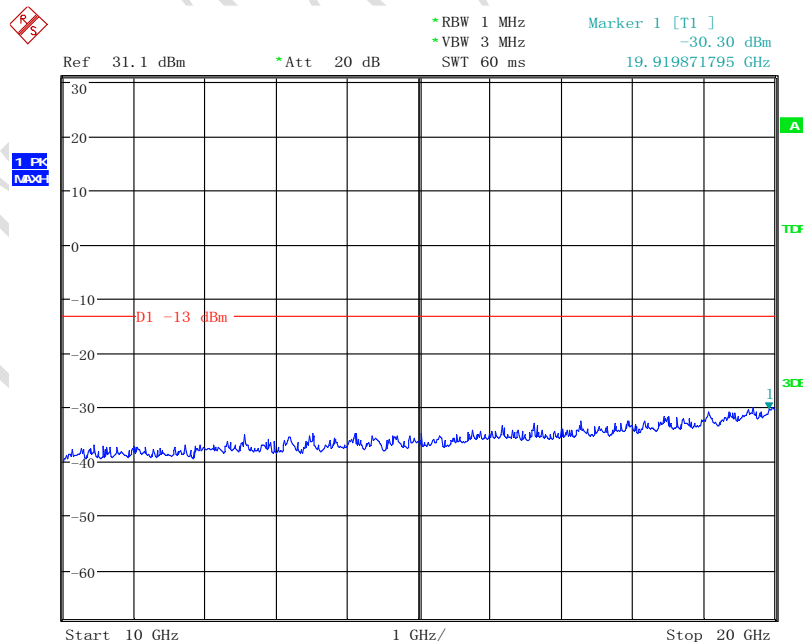

Date: 9.FEB.2015 08:32:28

16QAM, Low channel, 826.4 MHz, 30MHz to 1GHz

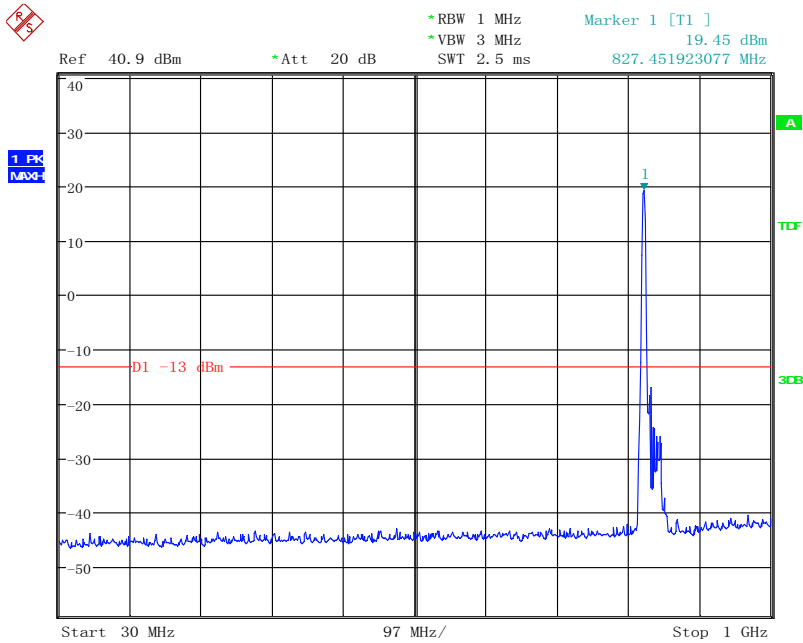

Date: 9.FEB.2015 11:30:03

Note: The strong emission shown in each case is the carrier signal.

16QAM, Low channel, 826.4 MHz, 1GHz to 10GHz

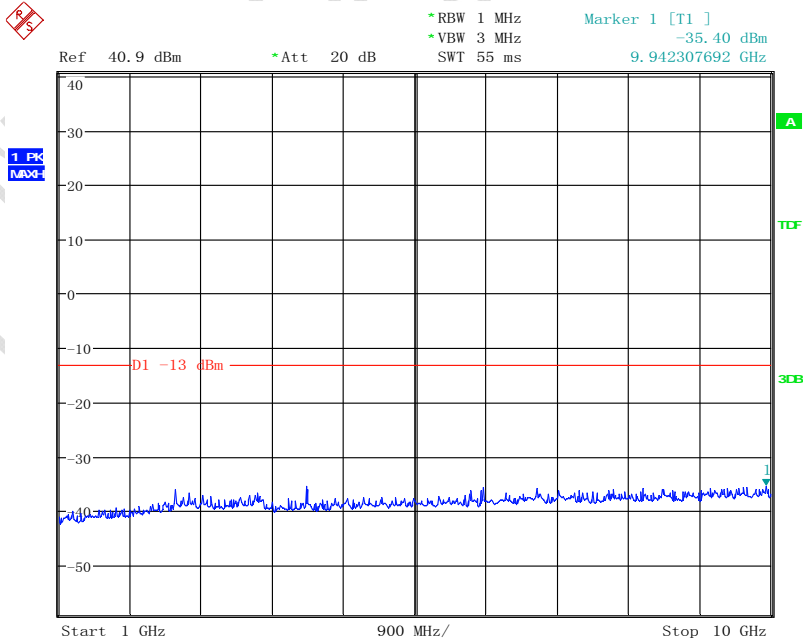

Date: 9.FEB.2015 11:30:23

FCC Parts 2, 22, 24
Equipment: Ilium X400

REPORT NO.: B15X50050-FCC-RF_Rev2

16QAM, Low channel, 826.4 MHz, 10GHz to 20GHz

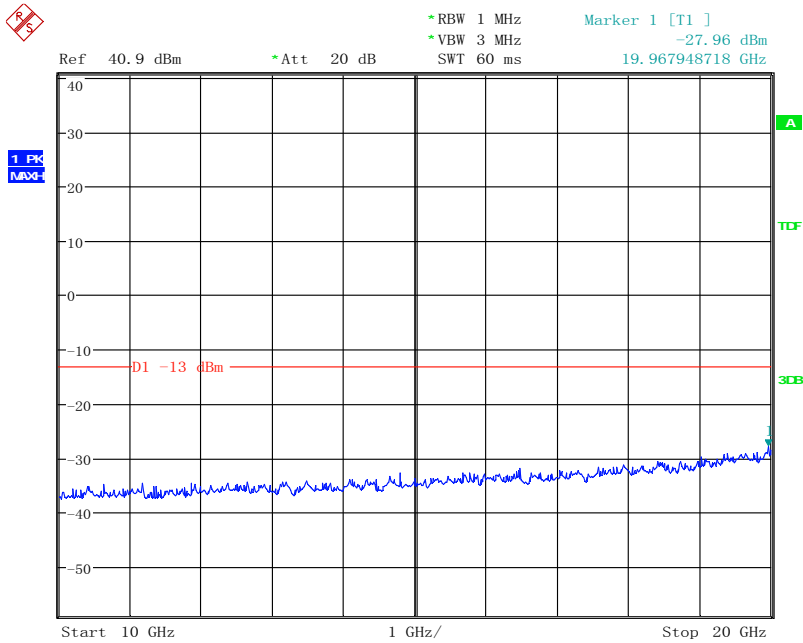

Date: 9.FEB.2015 11:30:39

16QAM, Middle channel, 836.4 MHz, 30MHz to 1GHz

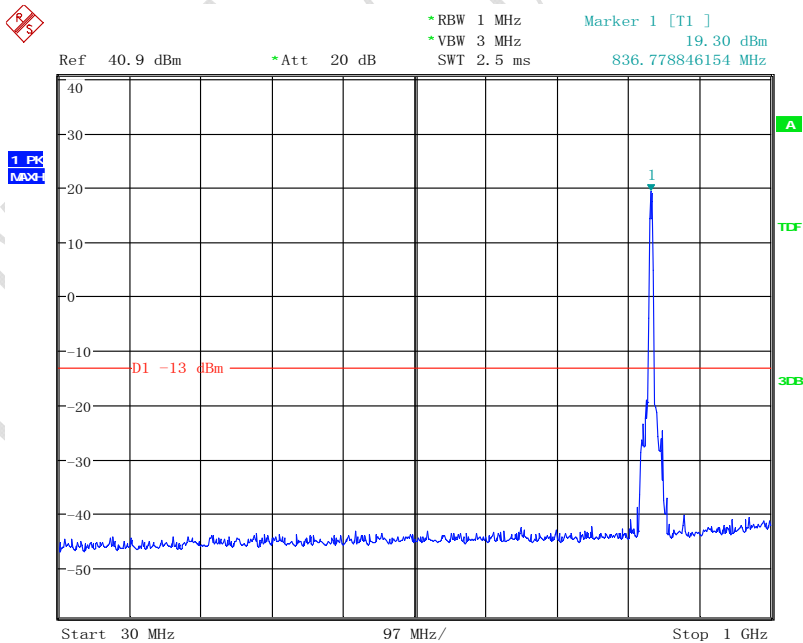

Date: 9.FEB.2015 11:31:03

Note: The strong emission shown in each case is the carrier signal.

FCC Parts 2, 22, 24
Equipment: Ilium X400

REPORT NO.: B15X50050-FCC-RF_Rev2

16QAM, Middle channel, 836.4 MHz, 1GHz to 10GHz

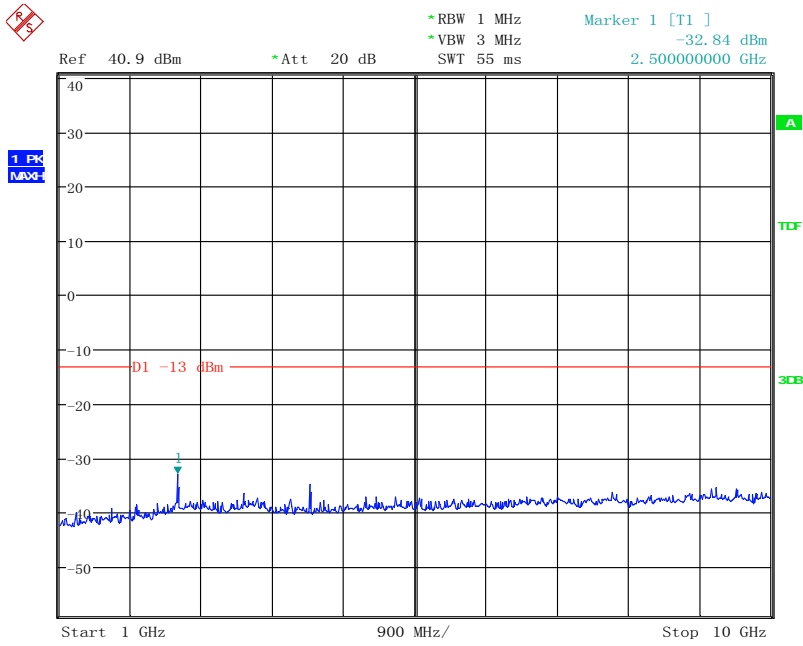

Date: 9.FEB.2015 11:31:16

16QAM, Middle channel, 836.4 MHz, 10GHz to 20GHz

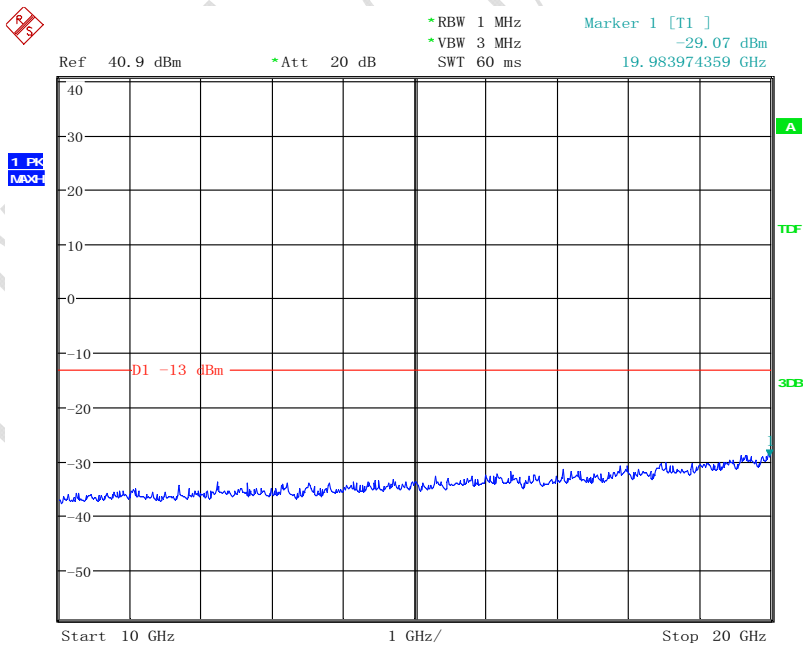

Date: 9.FEB.2015 11:31:29

16QAM, High Channel, 846.6 MHz, 30MHz to 1GHz

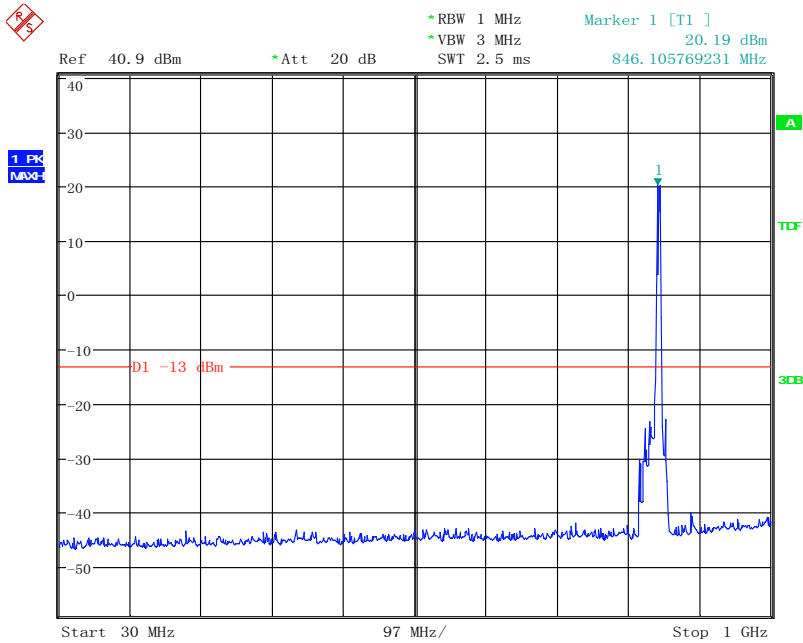

Date: 9.FEB.2015 11:31:51

Note: The strong emission shown in each case is the carrier signal.

16QAM, High Channel, 846.6 MHz, 1GHz to 10GHz

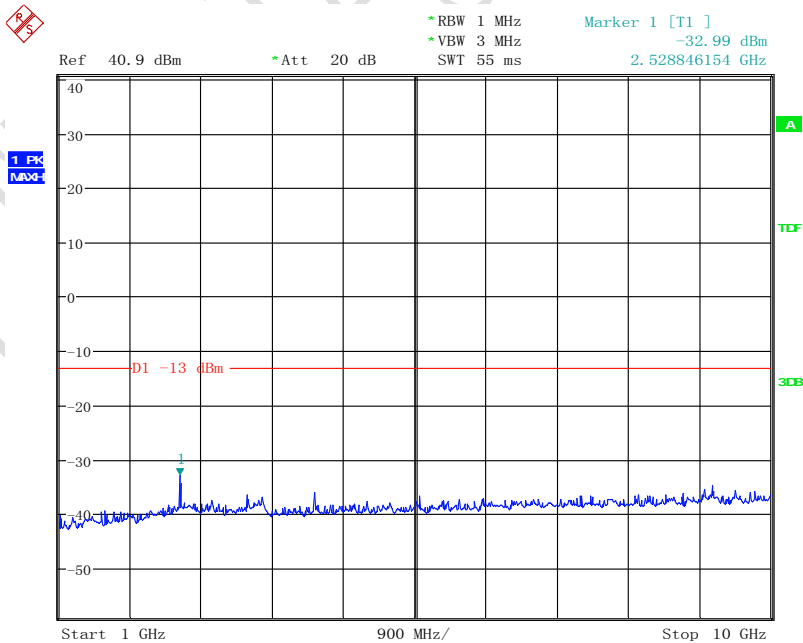

Date: 9.FEB.2015 11:32:05

FCC Parts 2, 22, 24
Equipment: Ilium X400

REPORT NO.: B15X50050-FCC-RF_Rev2

16QAM, High Channel, 846.6 MHz, 10GHz to 20GHz

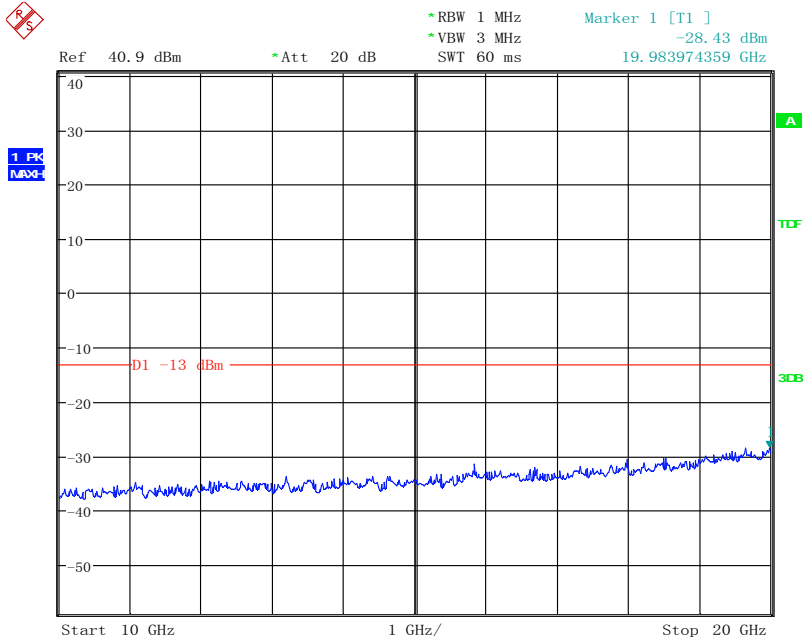

Date: 9.FEB.2015 11:32:16

16QAM, Low channel, 1852.4 MHz, 30MHz to 1GHz

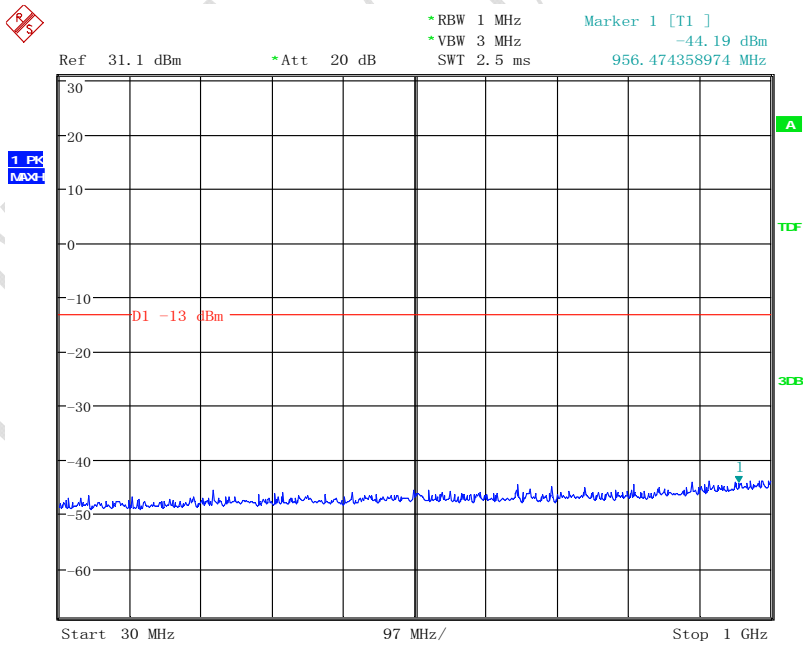

Date: 9.FEB.2015 08:39:19

16QAM, Low channel, 1852.4 MHz, 1GHz to 10GHz

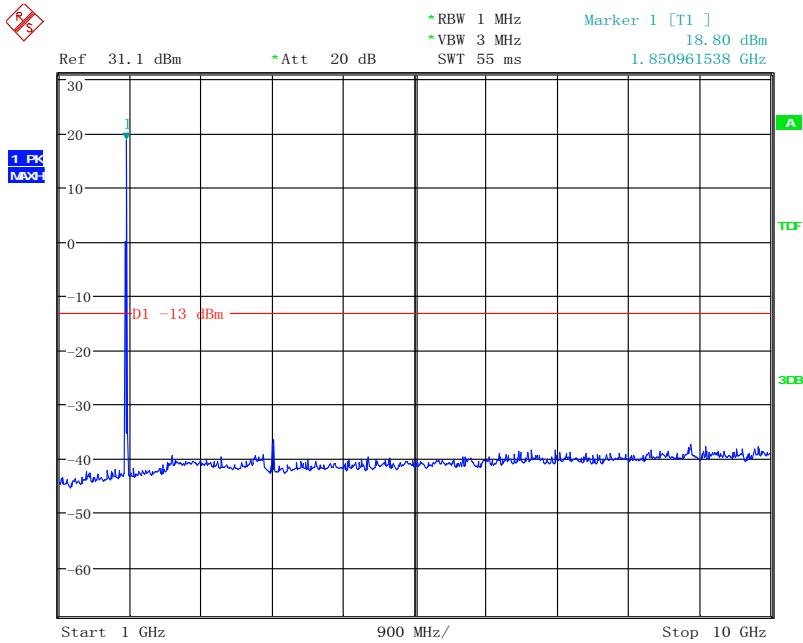

Date: 9.FEB.2015 08:39:32

Note: The strong emission shown is the carrier signal.

16QAM, Low channel, 1852.4 MHz, 10GHz to 20GHz

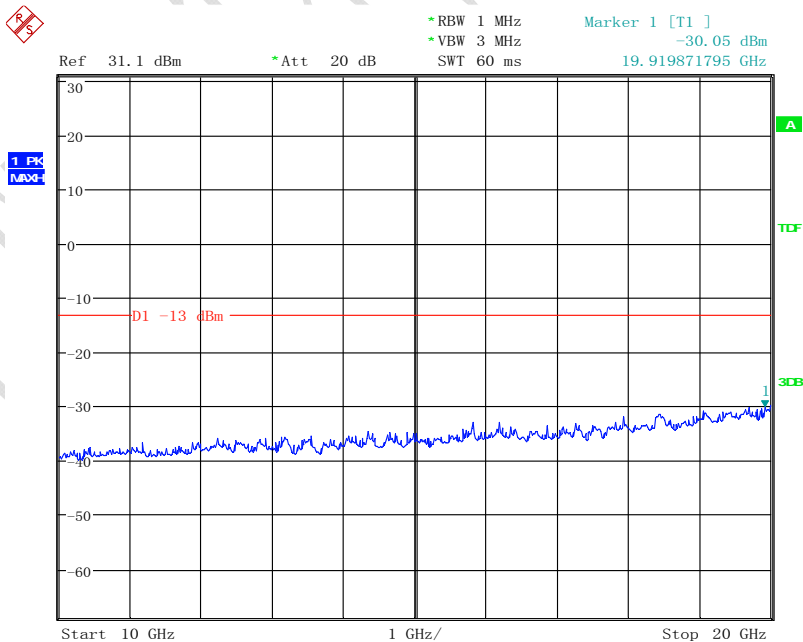

Date: 9.FEB.2015 08:39:44

FCC Parts 2, 22, 24
Equipment: Ilium X400

REPORT NO.: B15X50050-FCC-RF_Rev2

16QAM, Middle channel, 1880 MHz, 30MHz to 1GHz

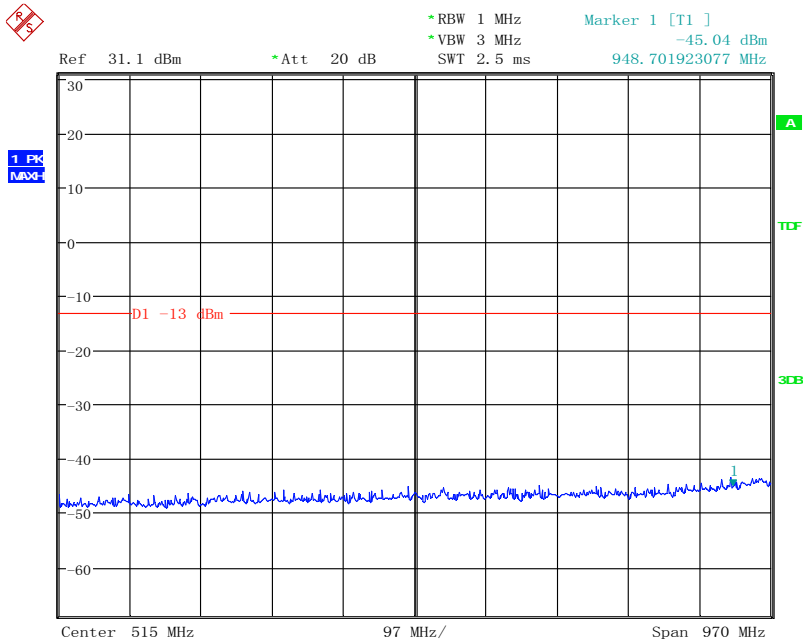

Date: 9.FEB.2015 08:40:14

16QAM, Middle channel, 1880 MHz, 1GHz to 10GHz

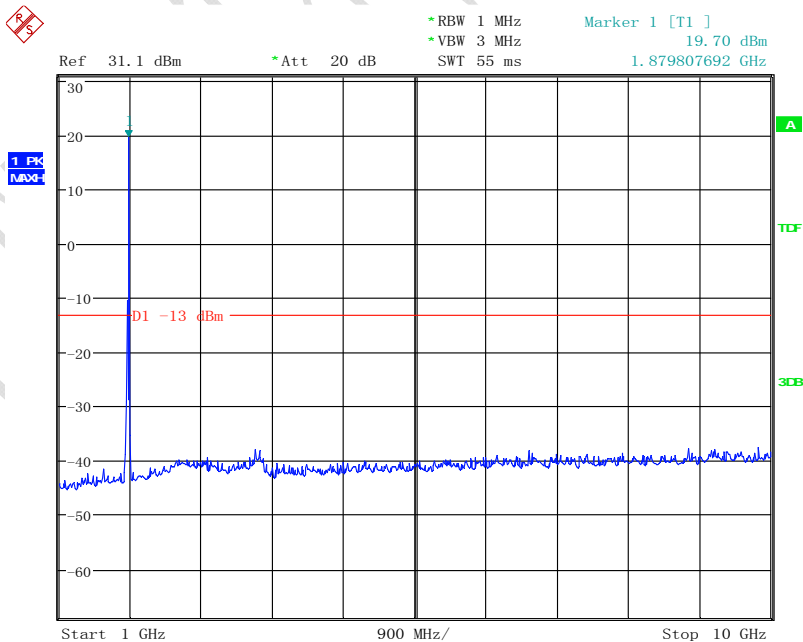

Date: 9.FEB.2015 08:40:25

Note: The strong emission shown is the carrier signal.

FCC Parts 2, 22, 24
Equipment: Ilium X400

REPORT NO.: B15X50050-FCC-RF_Rev2

16QAM, Middle channel, 1880 MHz, 10GHz to 20GHz

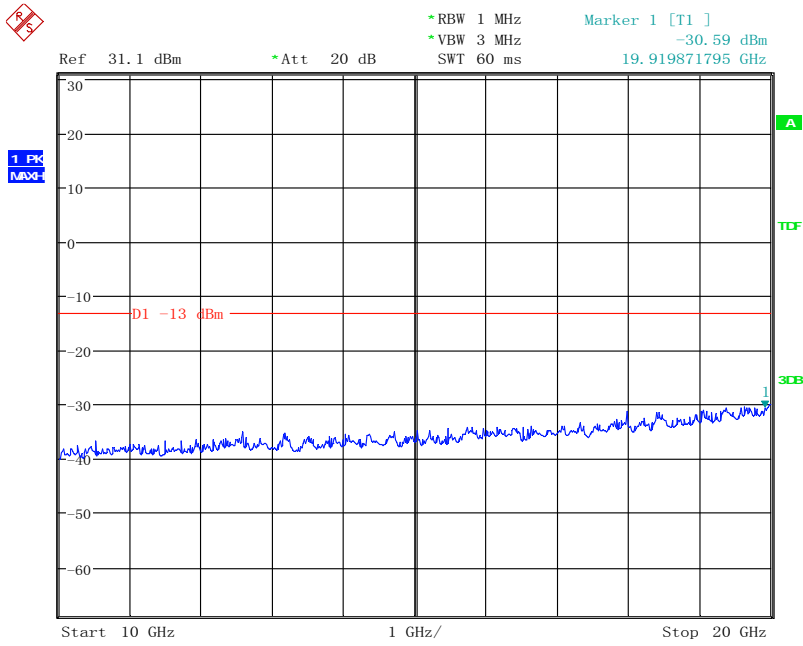

Date: 9.FEB.2015 08:40:37

16QAM, High channel, 1907.6 MHz, 30MHz to 1GHz

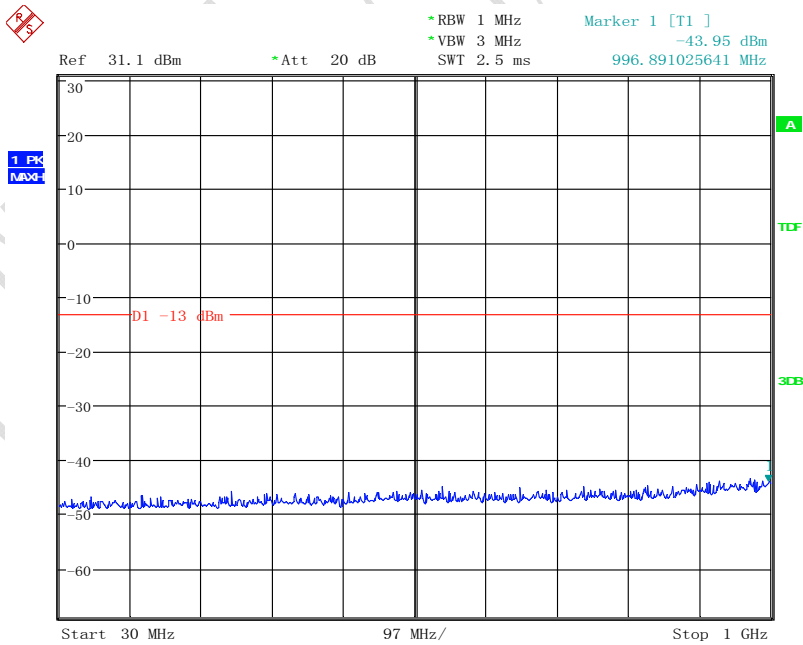

Date: 9.FEB.2015 08:41:04

FCC Parts 2, 22, 24
Equipment: Ilium X400

REPORT NO.: B15X50050-FCC-RF_Rev2

16QAM, High channel, 1907.6 MHz, 1GHz to 10GHz

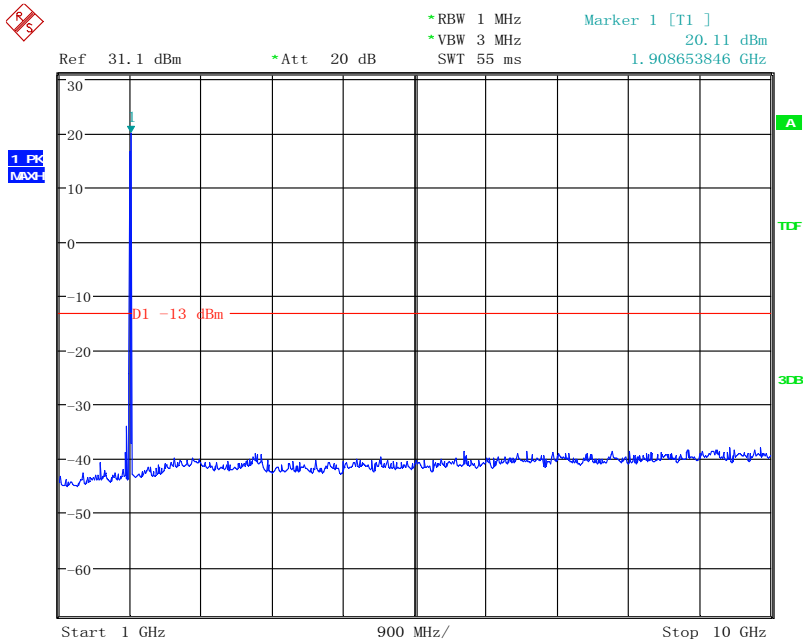

Date: 9.FEB.2015 08:41:15

Note: The strong emission shown is the carrier signal.

16QAM, High channel, 1907.6 MHz, 10GHz to 20GHz

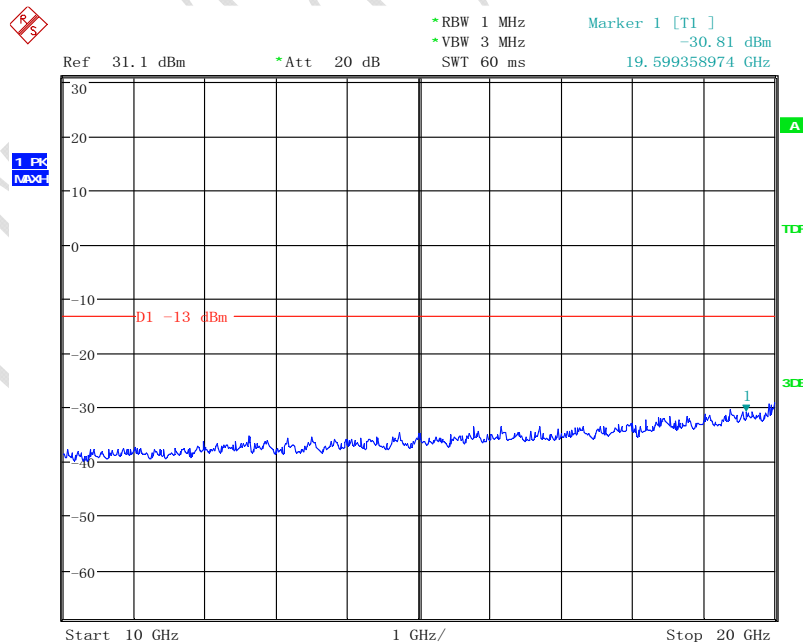

Date: 9.FEB.2015 08:41:28

4.7 Band Edge

Specifications:	2.1051, 24.238, 2.1053, 22.917
Date of Tests	2015-02-09
Test conditions:	Ambient Temperature: 15°C-35°C Relative Humidity: 30%-60% Air pressure: 86-106kPa
Operation Mode	TX on, channel 128, 251 and 512, 810 for GSM/GPRS/EGPRS mode, channel 4132, 4233 and 9262, 9538 for WCDMA/HSUPA/HSDPA mode.
Test Results:	Pass

Limit Level Construction:

According to Part 24.238 (a), i.e., Out of band emissions. The power of any emission outside of the authorized operating frequency ranges must be attenuated below the transmitting power (P) by a factor of at least $43 + 10 \log(P)$ dB, so the limit level is:

$$P(\text{dBm}) - (43 + 10 \log(P)) \text{ dB} = -13\text{dBm}$$

Limits for Radiated spurious emissions

Frequency range	Limit Level
Band edge	-13dBm

Test Setup:

During the test, the EUT was controlled via the Wireless Communications Test Set to ensure max power transmission and proper modulation and measured by spectrum analyzer.

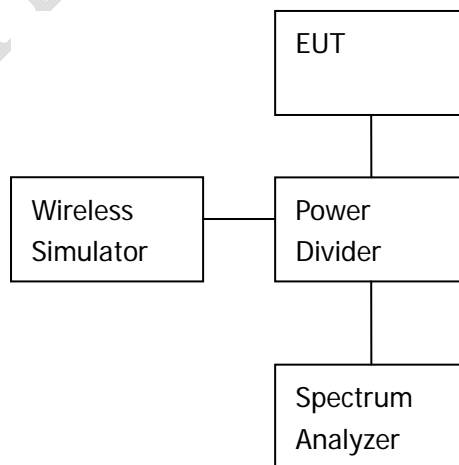

Test Method

- 1) The EUT was coupled to the EMI test receiver analyzer mode and the base station simulator through a power divider. The loss of the cables the test system is calibrated to correct the readings.
- 2) The spectrum analyzer was set to Maxpeak Detector function and Maximum hold mode.
- 3) The resolution bandwidth of the spectrum analyzer was a little greater than 1% of the 26dB emission bandwidth.

Note: --

China Test Report

FCC Parts 2, 22, 24
Equipment: Ilium X400

REPORT NO.: B15X50050-FCC-RF_Rev2

Test Results:

Graphical results:

GMSK; Cellular low channel, below 824 MHz

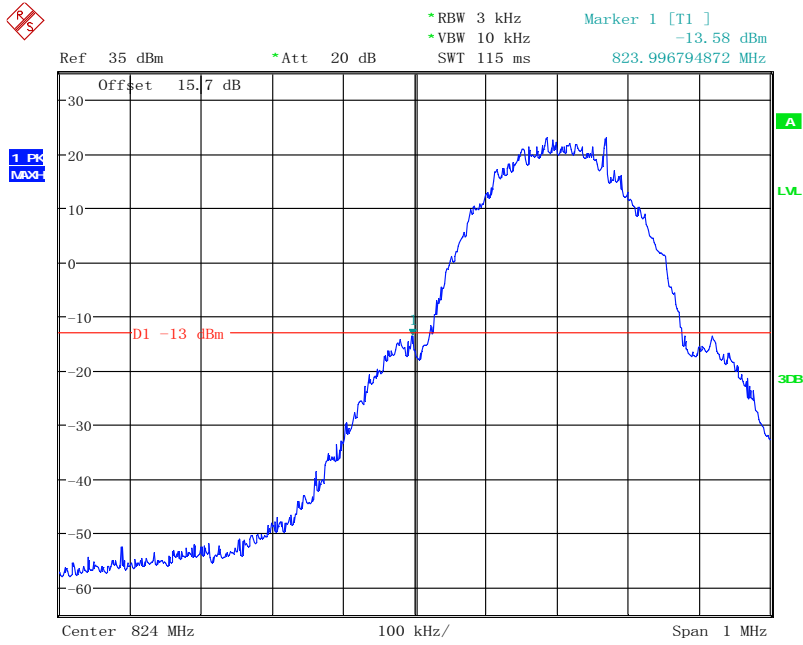

Date: 9. FEB. 2015 07:09:26

GMSK; Cellular high channel, above 849 MHz

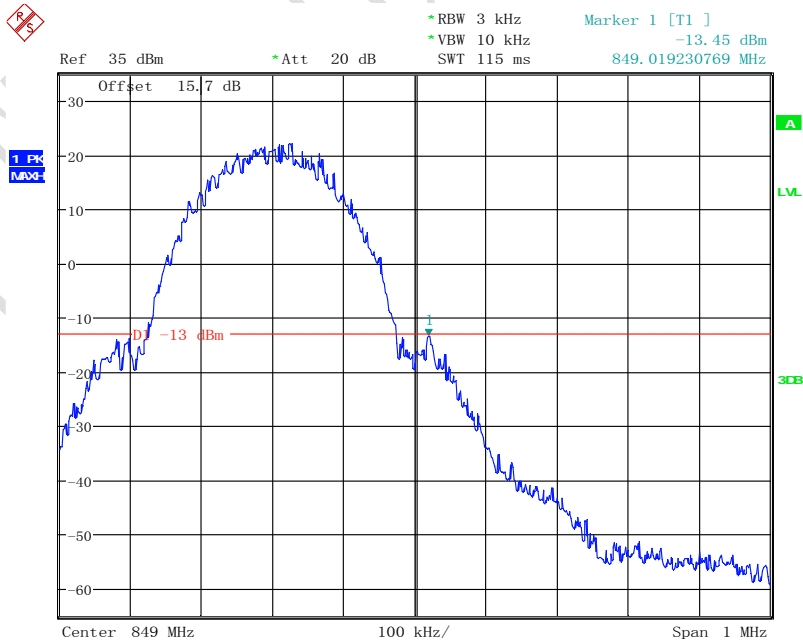

Date: 9. FEB. 2015 07:10:44

8PSK; Cellular low channel, below 824 MHz

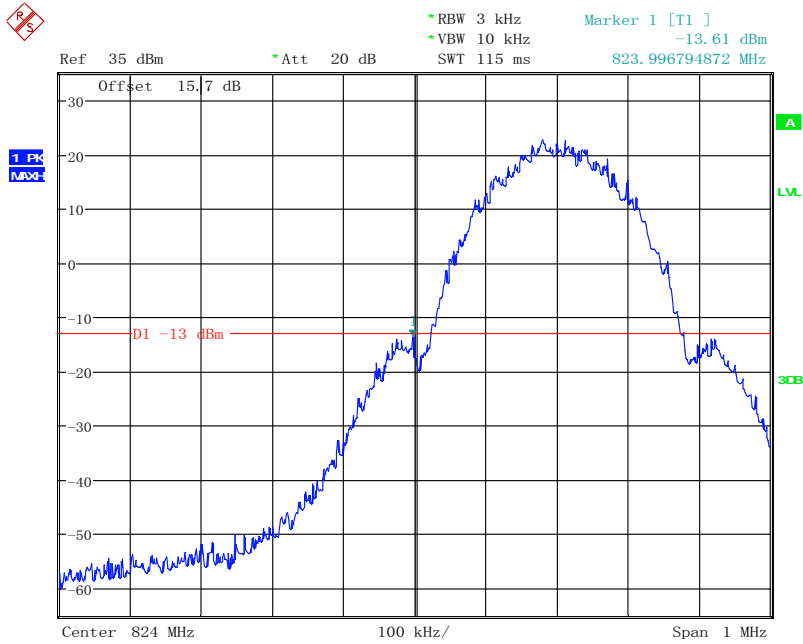

Date: 9.FEB.2015 07:12:22

8PSK; Cellular high channel, above 849 MHz

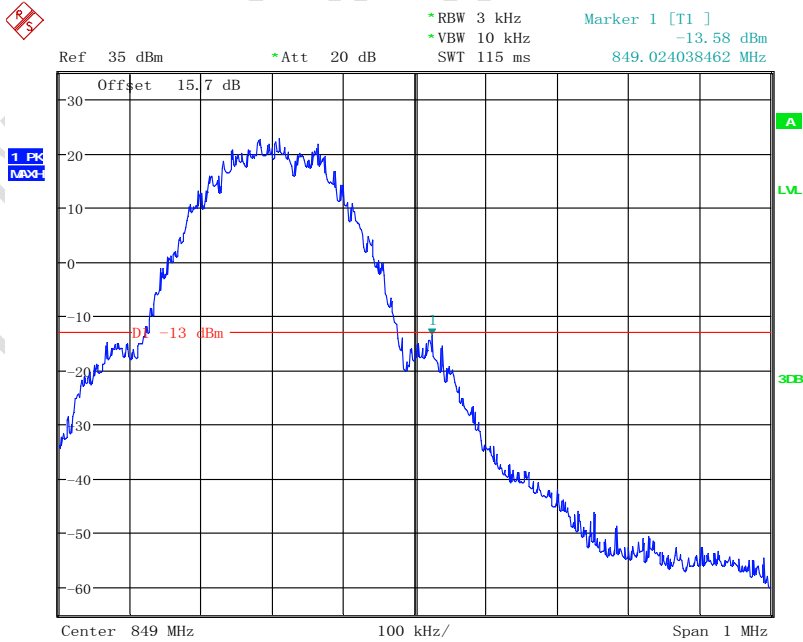

Date: 9.FEB.2015 07:12:58

FCC Parts 2, 22, 24
Equipment: Ilium X400

REPORT NO.: B15X50050-FCC-RF_Rev2

GMSK; PCS low channel, below 1850 MHz

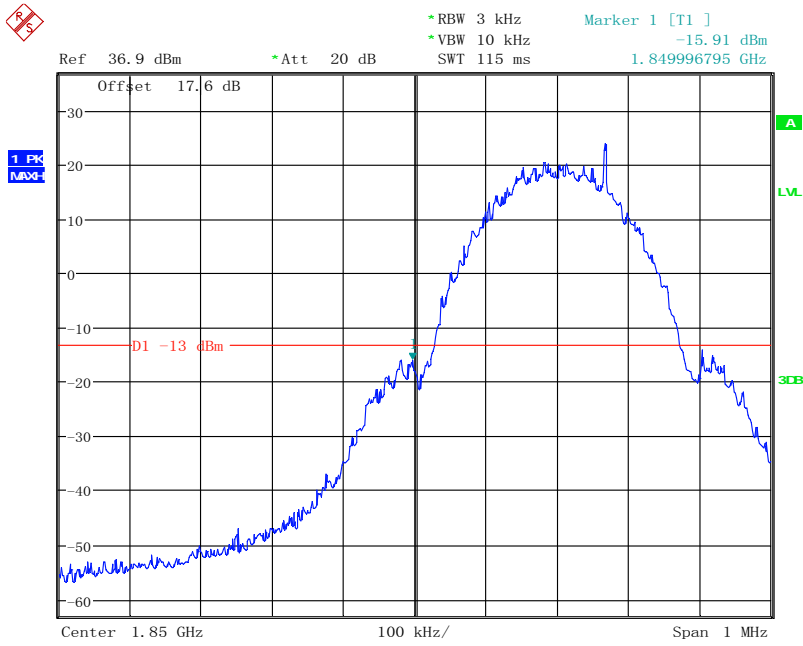

Date: 9.FEB.2015 07:15:52

GMSK; PCS high channel, above 1910 MHz

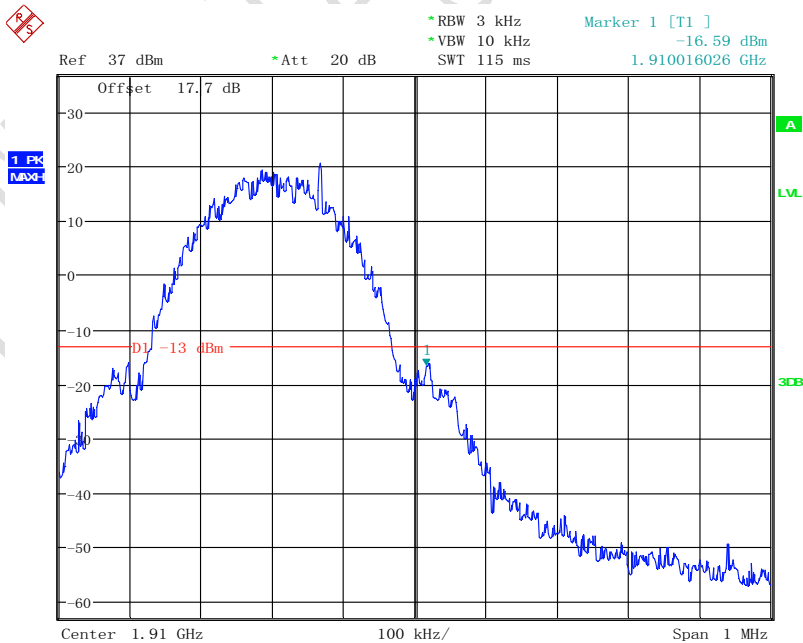

Date: 9.FEB.2015 07:17:10

8PSK; PCS low channel, below 1850 MHz

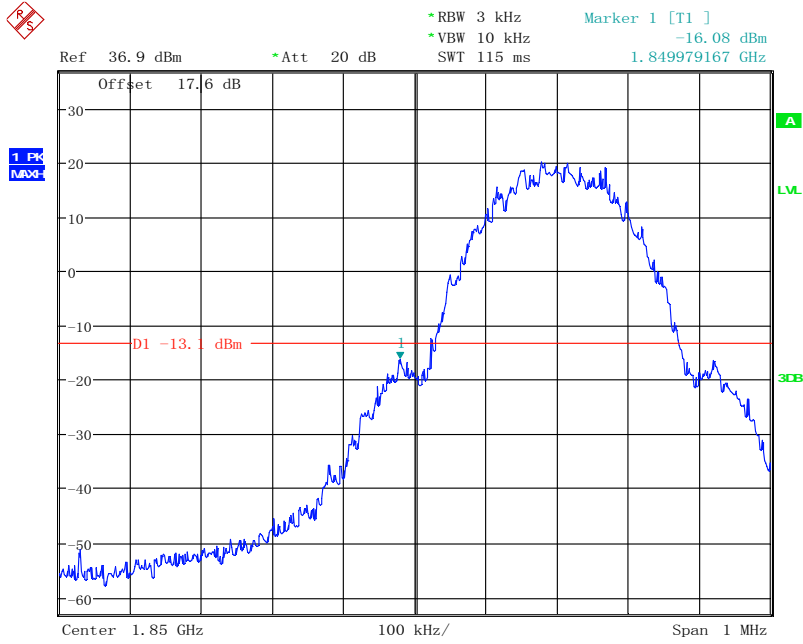

Date: 9. FEB. 2015 07:20:16

8PSK; PCS high channel, above 1910 MHz

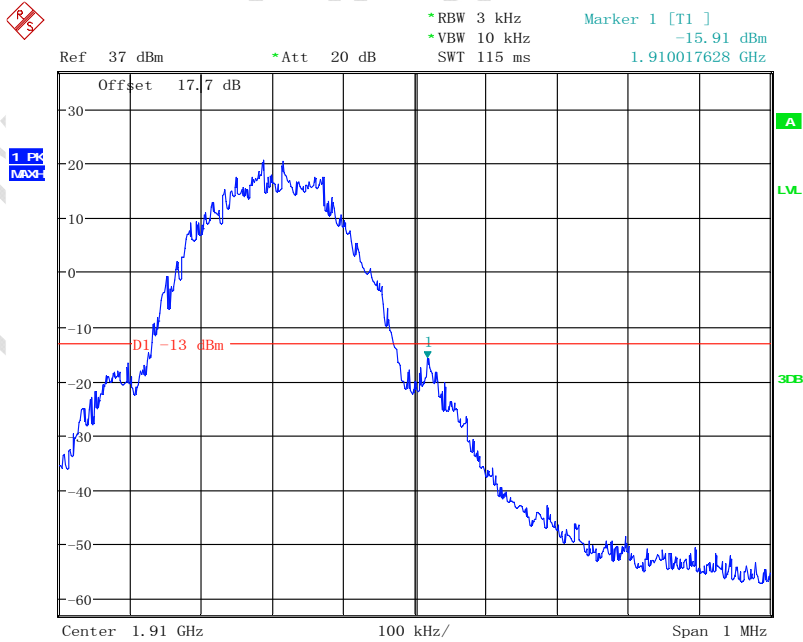

Date: 9. FEB. 2015 07:20:52

QPSK; Cellular low channel, below 824 MHz

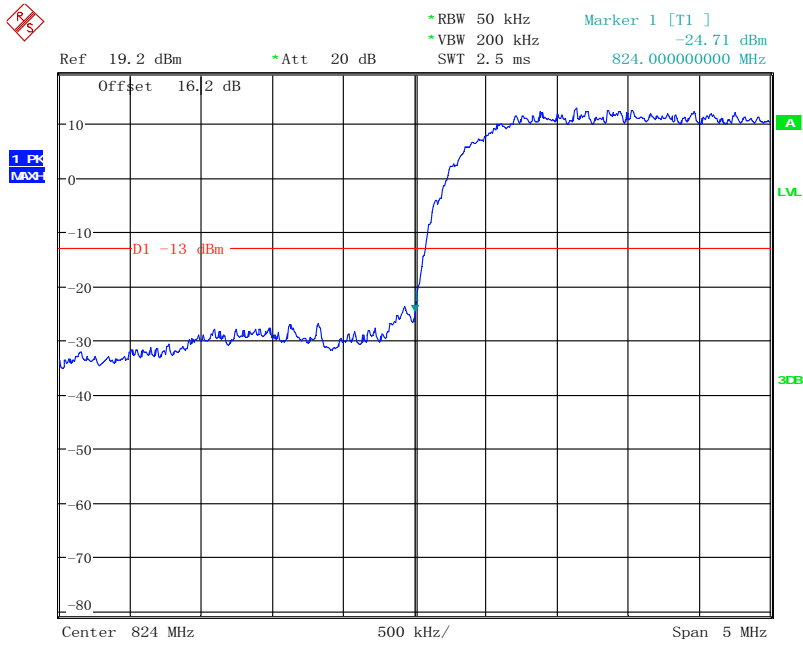

Date: 9.FEB.2015 10:54:29

QPSK; Cellular high channel, above 849 MHz

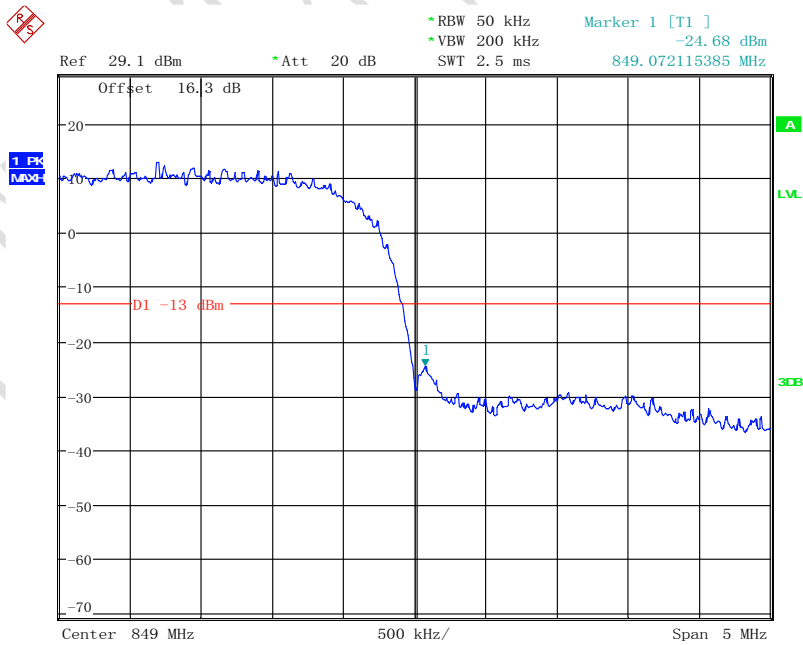

Date: 9.FEB.2015 10:58:07

FCC Parts 2, 22, 24
Equipment: Ilium X400

REPORT NO.: B15X50050-FCC-RF_Rev2

QPSK; PCS low channel, below 1850 MHz

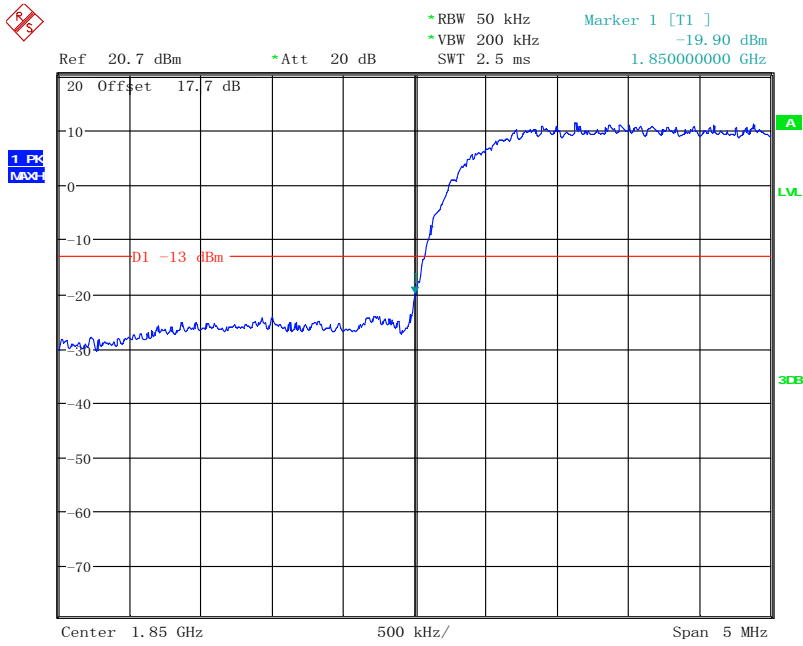

Date: 9.FEB.2015 08:08:40

QPSK; PCS high channel, above 1910 MHz

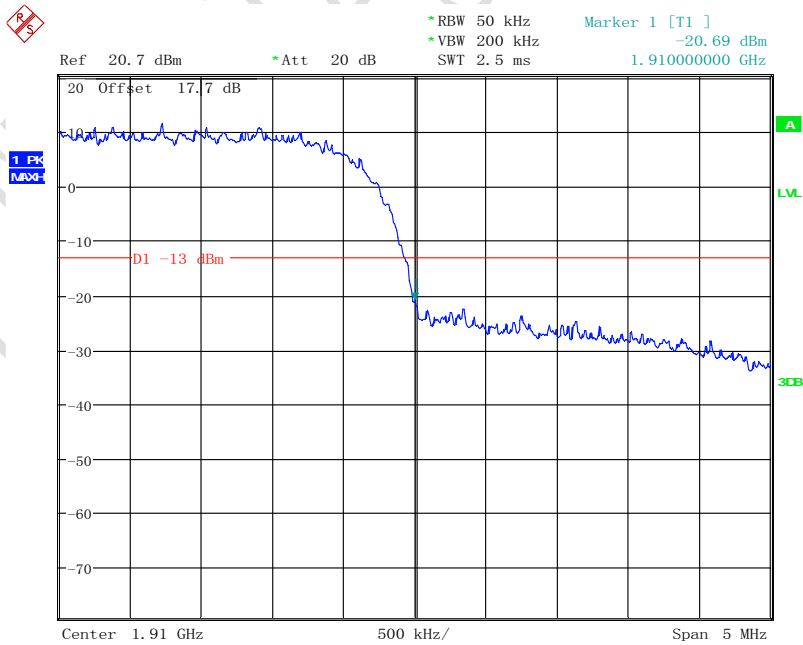

Date: 9.FEB.2015 08:09:32

16QAM; Cellular low channel, below 824 MHz

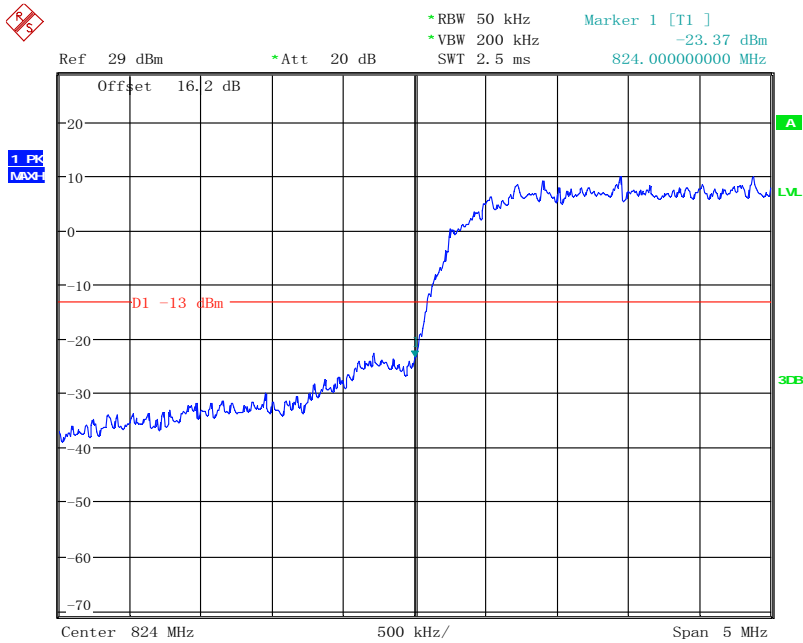

Date: 9.FEB.2015 11:02:31

16QAM; Cellular high channel, above 849 MHz

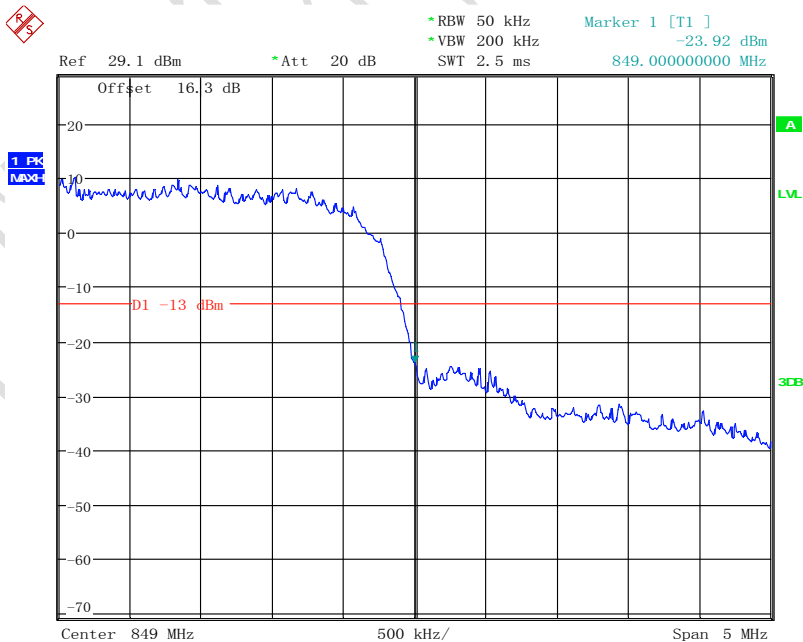

Date: 9.FEB.2015 11:03:19

FCC Parts 2, 22, 24
Equipment: Ilium X400

REPORT NO.: B15X50050-FCC-RF_Rev2

16QAM; PCS low channel, below 1850 MHz

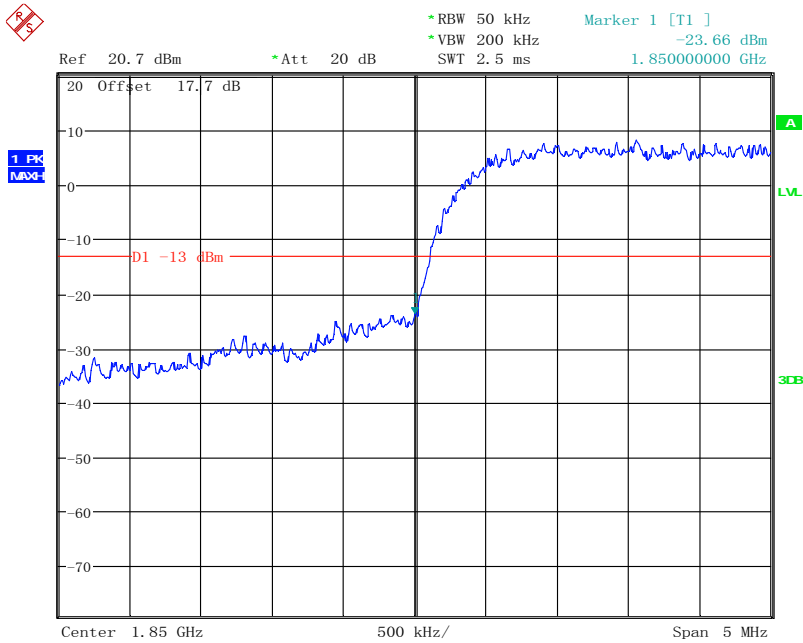

Date: 9.FEB.2015 08:10:53

16QAM; PCS high channel, above 1910 MHz

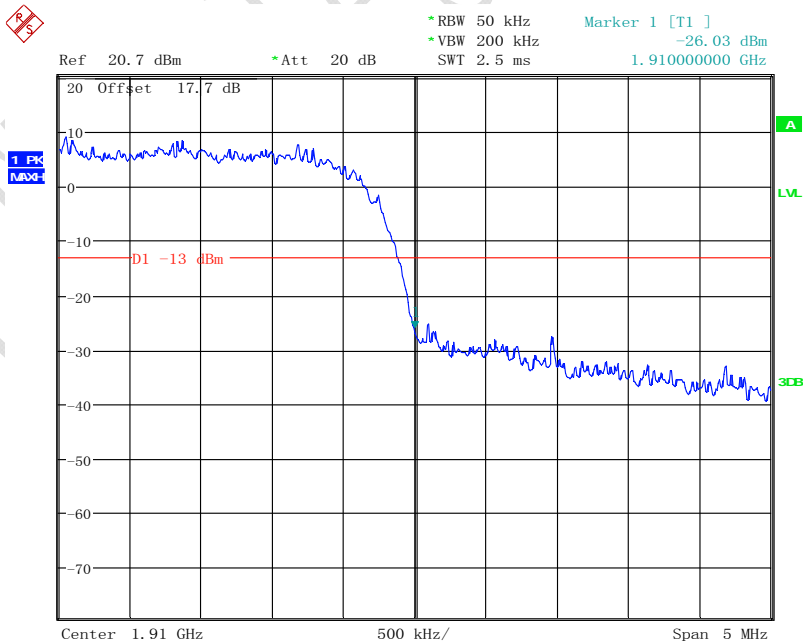

Date: 9.FEB.2015 08:12:18

4.8 ERP and EIRP

Specifications:	22.913(a), 24.232(b)
Date of Tests	2015-02-12-2015-04-09
Test conditions:	Ambient Temperature:15°C-35°C Relative Humidity:30%-60% Air pressure: 86-106kPa
Operation Mode	TX on, channel 128,190,251,512, 661 and 810 for GSM/GPRS/EGPRS mode, channel 12,9400,9538,782,4182 and 4233 for WCDMA/HSUPA/HSDPA mode.
Test Results:	Pass

Limit Level Construction:

Part 22:

According to Part 22.913(a)(2):The ERP of mobile transmitters and auxiliary test transmitters must not exceed 7 Watts.

Part 24:

According to Part 24.232(b):The EIRP of mobile transmitters and auxiliary test transmitters must not exceed 2 Watts.

Test Setup:

The EUT was placed in an anechoic chamber. The Communications Test Set was used to set the TX channel and power level and modulate the TX signal with different bit patterns.

Test Method:

The measurement method is substitution method accordance with section 2.2.12 of ANSI/TIA-603-C: *Land Mobile FM or PM Communications Equipment Measurement and Performance Standards*.

- (a) Connect the equipment as illustrated and measure the spurious emissions as the method as above.

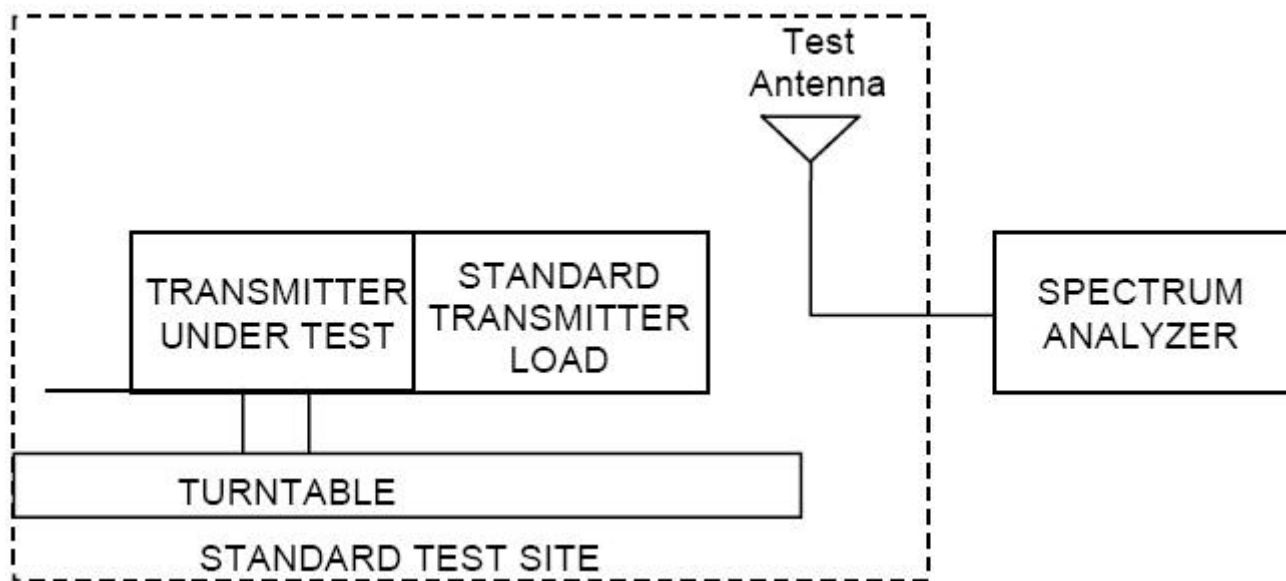

(b) Reconnect the equipment as illustrated.

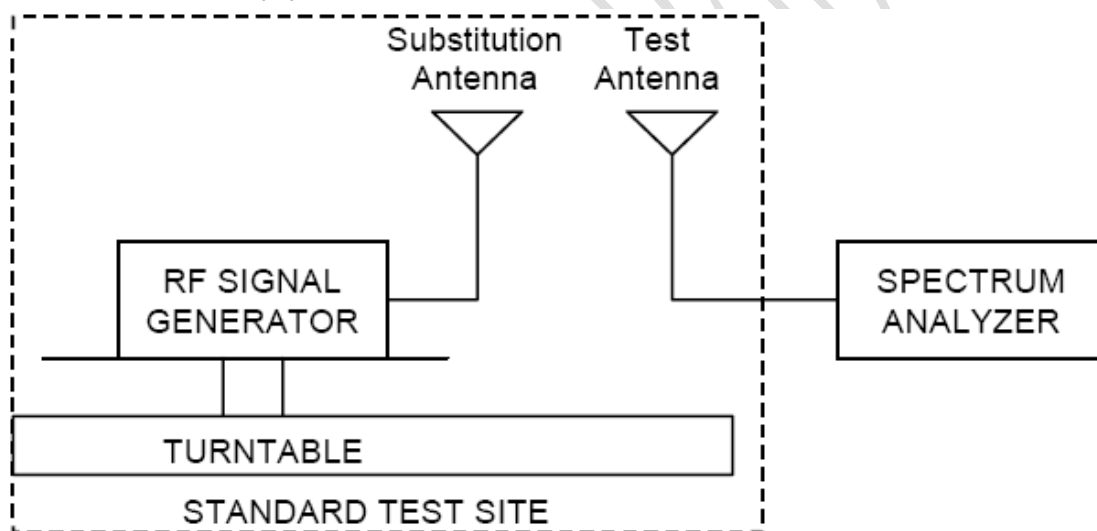

(c) Remove the transmitter and replace it with a substitution antenna. The center of the substitution antenna should be approximately at the same location as the center of the transmitter.

(d) Feed the substitution antenna at the transmitter end with a signal generator connected to the antenna by means of a non-radiating cable. With the antennas at both ends horizontally polarized, and with the signal generator tuned to a particular spurious frequency, raise and lower the test antenna to obtain a maximum reading at the spectrum analyzer. Adjust the level of the signal generator output until the previously recorded maximum reading for this set of conditions is obtained. This should be done carefully repeating the adjustment of the test antenna and generator output.

(e) Repeat step d) with both antennas vertically polarized for each spurious frequency.

(f) Calculate power in dBm into a reference ideal half-wave dipole antenna by reducing the readings obtained in steps d) and e) by the power loss in the cable between the generator and the antenna, and further corrected for the gain of the substitution antenna used

relative to an ideal half-wave dipole antenna by the following formula:

$$ERP = S.G \text{ output (dBm)} - \text{cable loss (dB)} + \text{antenna gain (dBd)}$$

$$EIRP = S.G \text{ output (dBm)} - \text{cable loss (dB)} + \text{antenna gain (dBi)}$$

TTL Test Report

Test Data (GSM 850 GSM)

Frequency [MHz]	S.G output [dBm]	Cable loss [dB]	Antenna Gain [dB]	ERP (P _d) [dBm]	Antenna Polarization [H/V]
824.2	33.28	3.4	-2.87	27.01	V
836.4	33.95	3.4	-3.11	27.44	V
848.8	33.58	3.4	-3.11	27.07	V
824.2	33.54	3.4	-2.87	27.27	H
836.4	33.55	3.4	-3.11	27.04	H
848.8	33.87	3.4	-3.11	27.36	H

Test Data (GSM 850 GPRS)

Frequency [MHz]	S.G output [dBm]	Cable loss [dB]	Antenna Gain [dB]	ERP (P _d) [dBm]	Antenna Polarization [H/V]
824.2	33.45	3.4	-2.87	27.18	V
836.4	33.86	3.4	-3.11	27.35	V
848.8	33.89	3.4	-3.11	27.38	V
824.2	33.56	3.4	-2.87	27.29	H
836.4	33.75	3.4	-3.11	27.24	H
848.8	33.83	3.4	-3.11	27.32	H

Test Data (GSM 850 EGPRS GMSK)

Frequency [MHz]	S.G output [dBm]	Cable loss [dB]	Antenna Gain [dB]	ERP (P _d) [dBm]	Antenna Polarization [H/V]
824.2	33.58	3.4	-2.87	27.31	V
836.4	33.89	3.4	-3.11	27.38	V
848.8	33.76	3.4	-3.11	27.25	V
824.2	33.72	3.4	-2.87	27.45	H
836.4	33.26	3.4	-3.11	26.75	H
848.8	33.46	3.4	-3.11	26.95	H

Test Data (GSM 850 EGPRS 8PSK)

Frequency [MHz]	S.G output [dBm]	Cable loss [dB]	Antenna Gain [dB]	ERP (P _d) [dBm]	Antenna Polarization [H/V]
824.2	31.53	3.4	-2.87	25.26	V
836.4	31.76	3.4	-3.11	25.25	V
848.8	31.64	3.4	-3.11	25.13	V
824.2	31.58	3.4	-2.87	25.31	H
836.4	31.35	3.4	-3.11	24.84	H
848.8	31.46	3.4	-3.11	24.95	H

Test Data (PCS 1900 GSM)

Frequency [MHz]	S.G output [dBm]	Cable loss [dB]	Antenna Gain [dB]	EIRP (P _d) [dBm]	Antenna Polarization [H/V]
1850.2	21.15	5.0	10.4	26.55	V
1880.0	21.28	5.0	10.4	26.68	V
1909.8	21.18	5.1	10.4	26.48	V
1850.2	21.40	5.0	10.4	26.80	H
1880.0	21.36	5.0	10.4	26.76	H
1909.8	20.97	5.1	10.4	26.27	H

Test Data (PCS 1900 GPRS)

Frequency [MHz]	S.G output [dBm]	Cable loss [dB]	Antenna Gain [dB]	EIRP (P _d) [dBm]	Antenna Polarization [H/V]
1850.2	21.36	5.0	10.4	26.76	V
1880.0	21.17	5.0	10.4	26.57	V
1909.8	21.15	5.1	10.4	26.45	V
1850.2	20.97	5.0	10.4	26.37	H
1880.0	21.45	5.0	10.4	26.85	H
1909.8	21.01	5.1	10.4	26.31	H

Test Data (PCS 1900 EGPRS GMSK)

Frequency [MHz]	S.G output [dBm]	Cable loss [dB]	Antenna Gain [dB]	EIRP (P _d) [dBm]	Antenna Polarization [H/V]
1850.2	20.78	5.0	10.4	26.18	V
1880.0	21.28	5.0	10.4	26.68	V
1909.8	21.07	5.1	10.4	26.37	V
1850.2	20.74	5.0	10.4	26.14	H
1880.0	21.51	5.0	10.4	26.91	H
1909.8	21.03	5.1	10.4	26.33	H

Test Data (PCS 1900 EGPRS 8PSK)

Frequency [MHz]	S.G output [dBm]	Cable loss [dB]	Antenna Gain [dB]	EIRP (P _d) [dBm]	Antenna Polarization [H/V]
1850.2	18.87	5.0	10.4	24.27	V
1880.0	19.35	5.0	10.4	24.75	V
1909.8	19.12	5.1	10.4	24.42	V
1850.2	18.85	5.0	10.4	24.25	H
1880.0	19.67	5.0	10.4	25.07	H
1909.8	19.21	5.1	10.4	24.51	H

Test Data (WCDMA Band II WCDMA)

Frequency [MHz]	S.G output [dBm]	Cable loss [dB]	Antenna Gain [dB]	EIRP (P _d) [dBm]	Antenna Polarization [H/V]
1852.4	16.35	5.0	10.4	21.75	V
1880.0	16.11	5.0	10.4	21.51	V
1907.6	16.08	5.1	10.4	21.38	V
1852.4	16.50	5.0	10.4	21.90	H
1880.0	15.20	5.0	10.4	20.60	H
1907.6	16.35	5.1	10.4	21.65	H

Test Data (WCDMA Band II HSDPA)

Frequency [MHz]	S.G output [dBm]	Cable loss [dB]	Antenna Gain [dB]	EIRP (P _d) [dBm]	Antenna Polarization [H/V]
1852.5	14.84	5.0	10.4	20.24	V
1880.0	14.51	5.0	10.4	19.91	V
1907.6	14.66	5.1	10.4	19.96	V
1852.5	15.24	5.0	10.4	20.64	H
1880.0	14.85	5.0	10.4	20.25	H
1907.6	14.34	5.1	10.4	20.64	H

Test Data (WCDMA Band II HSUPA QPSK)

Frequency [MHz]	S.G output [dBm]	Cable loss [dB]	Antenna Gain [dB]	EIRP (P _d) [dBm]	Antenna Polarization [H/V]
1852.5	13.31	5.0	10.4	18.71	V
1880.0	12.65	5.0	10.4	18.05	V
1907.6	12.73	5.1	10.4	18.03	V
1852.5	12.49	5.0	10.4	17.89	H
1880.0	12.98	5.0	10.4	18.38	H
1907.6	12.56	5.1	10.4	17.86	H

Test Data (WCDMA Band II HSUPA 16QAM)

Frequency [MHz]	S.G output [dBm]	Cable loss [dB]	Antenna Gain [dB]	EIRP (P _d) [dBm]	Antenna Polarization [H/V]
1852.5	13.24	5.0	10.4	18.64	V
1880.0	12.56	5.0	10.4	17.96	V
1907.6	12.68	5.1	10.4	17.98	V
1852.5	13.48	5.0	10.4	18.88	H
1880.0	12.98	5.0	10.4	18.38	H
1907.6	12.35	5.1	10.4	17.65	H

Test Data (WCDMA Band V WCDMA)

Frequency [GHz]	S.G output [dBm]	Cable loss [dB]	Antenna Gain [dB]	ERP (P _d) [dBm]	Antenna Polarization [H/V]
826.4	27.05	3.4	-2.87	18.63	V
836.4	26.92	3.4	-3.11	18.26	V
846.4	27.01	3.4	-3.11	18.35	V
826.4	27.12	3.4	-2.87	18.70	H
836.4	26.62	3.4	-3.11	17.96	H
846.4	26.48	3.4	-3.11	17.82	H

Test Data (WCDMA Band V HSDPA)

Frequency [GHz]	S.G output [dBm]	Cable loss [dB]	Antenna Gain [dB]	ERP (P _d) [dBm]	Antenna Polarization [H/V]
824.2	26.96	3.4	-2.87	18.54	V
836.4	27.24	3.4	-3.11	18.58	V
848.8	27.01	3.4	-3.11	18.35	V
824.2	26.74	3.4	-2.87	18.32	H
836.4	27.48	3.4	-3.11	18.82	H
848.8	27.04	3.4	-3.11	18.38	H

Test Data (WCDMA Band V HSUPA QPSK)

Frequency [GHz]	S.G output [dBm]	Cable loss [dB]	Antenna Gain [dB]	ERP (P _d) [dBm]	Antenna Polarization [H/V]
824.2	26.01	3.4	-2.87	17.59	V
836.4	25.79	3.4	-3.11	17.13	V
848.8	25.61	3.4	-3.11	16.95	V
824.2	25.43	3.4	-2.87	17.01	H
836.4	25.98	3.4	-3.11	17.32	H
848.8	25.78	3.4	-3.11	17.12	H

Test Data (WCDMA Band V HSUPA 16QAM)

Frequency [GHz]	S.G output [dBm]	Cable loss [dB]	Antenna Gain [dB]	ERP (P _d) [dBm]	Antenna Polarization [H/V]
824.2	25.25	3.4	-2.87	16.83	V
836.4	25.58	3.4	-3.11	16.92	V
848.8	24.56	3.4	-3.11	15.90	V
824.2	25.14	3.4	-2.87	16.72	H
836.4	25.48	3.4	-3.11	16.82	H
848.8	24.78	3.4	-3.11	16.12	H

Annex A External Photos

See the document "Ilium X400- External Photos".

Annex B Internal Photos

See the document "Ilium X400-Internal Photos".

ANNEX C Deviations from Prescribed Test Methods

No deviation from Prescribed Test Methods.

_____ The End of this Report _____