



BUREAU
VERITAS

Test Report No.: RF170118W005-4



Test Lab
Cert 2951.01

FCC TEST REPORT

(PART 24)

Product: smartphone

Model Name: Ilium X120

FCC ID: ZC4X120

Applicant: Corporativo Lanix S.A.de C.V.

Address: Carretera Internacional Hermosillo - Nogales Km 8.5 Hermosillo,
Sonora, México

Manufacturer: Corporativo Lanix S.A.de C.V.

Address: Carretera Internacional Hermosillo - Nogales Km 8.5 Hermosillo,
Sonora, México

Prepared by: Bureau Veritas Shenzhen Co., Ltd. Dongguan Branch

Lab Location: No. 34, Chenwulu Section, Guantai Rd., Houjie Town, Dongguan
City, Guangdong 523942, China

TEL: +86 769 8593 5656

FAX: +86 769 8593 1080

E-MAIL: customerservice.dg@cn.bureauveritas.com

Report No.: RF170118W005-4

Received Date: Jan. 18, 2017

Test Date: Feb. 03, 2017 ~ Mar. 01, 2017

Issued Date: Mar. 02, 2017

This report should not be used by the client to claim product certification, approval, or endorsement by A2LA or any government agencies.

This report is for your exclusive use. Any copying or replication of this report to or for any other person or entity, or use of our name or trademark, is permitted only with our prior written permission. This report sets forth our findings solely with respect to the test samples identified herein. The results set forth in this report are not indicative or representative of the quality or characteristics of the lot from which a test sample was taken or any similar or identical product unless specifically and expressly noted. Our report includes all of the tests requested by you and the results thereof based upon the information that you provided to us. You have 60 days from date of issuance of this report to notify us of any material error or omission caused by our negligence, provided, however, that such notice shall be in writing and shall specifically address the issue you wish to raise. A failure to raise such issue within the prescribed time shall constitute your unqualified acceptance of the completeness of this report, the tests conducted and the correctness of the report contents. Unless specific mention, the uncertainty of measurement has been explicitly taken into account to declare the compliance or non-compliance to the specification.

Bureau Veritas Shenzhen Co., Ltd.
Dongguan Branch

No. 34, Chenwulu Section, Guantai Rd.,
Houjie Town, Dongguan City,
Guangdong 523942, China

Tel: +86 769 8593 5656
Fax: +86 769 8593 1080
Email: customerservice.dg@cn.bureauveritas.com



TABLE OF CONTENTS

RELEASE CONTROL RECORD 4

1 CERTIFICATION 5

2 SUMMARY OF TEST RESULTS 6

2.1 MEASUREMENT UNCERTAINTY 6

2.2 TEST SITE AND INSTRUMENTS 7

3 GENERAL INFORMATION 8

3.1 GENERAL DESCRIPTION OF EUT 8

3.2 CONFIGURATION OF SYSTEM UNDER TEST 8

3.3 DESCRIPTION OF SUPPORT UNITS 11

3.4 TEST ITEM AND TEST CONFIGURATION 11

3.5 EUT OPERATING CONDITIONS 13

3.6 GENERAL DESCRIPTION OF APPLIED STANDARDS 13

4 TEST TYPES AND RESULTS 14

4.1 OUTPUT POWER MEASUREMENT 14

4.1.1 LIMITS OF OUTPUT POWER MEASUREMENT 14

4.1.2 TEST PROCEDURES 14

4.1.3 TEST SETUP 15

4.1.4 TEST RESULTS 16

4.2 FREQUENCY STABILITY MEASUREMENT 18

4.2.1 LIMITS OF FREQUENCY STABILITY MEASUREMENT 18

4.2.2 TEST PROCEDURE 18

4.2.3 TEST SETUP 18

4.2.4 TEST RESULTS 19

4.3 OCCUPIED BANDWIDTH MEASUREMENT 21

4.3.1 TEST PROCEDURES 21

4.3.2 TEST SETUP 21

4.3.3 TEST RESULTS 22

4.4 BAND EDGE MEASUREMENT 24

4.4.1 LIMITS OF BAND EDGE MEASUREMENT 24

4.4.2 TEST SETUP 24

4.4.3 TEST PROCEDURES 24

4.4.4 TEST RESULTS 25

4.5 CONDUCTED SPURIOUS EMISSIONS 26

4.5.1 LIMITS OF CONDUCTED SPURIOUS EMISSIONS MEASUREMENT 26

4.5.2 TEST PROCEDURE 26

4.5.3 TEST SETUP 26

4.5.4 TEST RESULTS 27

4.6 RADIATED EMISSION MEASUREMENT 29

4.6.1 LIMITS OF RADIATED EMISSION MEASUREMENT 29

4.6.2 TEST PROCEDURES 29

4.6.3 DEVIATION FROM TEST STANDARD 29

4.6.4 TEST SETUP 30

4.6.5 TEST RESULTS 31



Test Report No.: RF170118W005-4

4.7 PEAK TO AVERAGE RATIO37

4.7.1 LIMITS OF PEAK TO AVERAGE RATIO MEASUREMENT.....37

4.7.2 TEST SETUP.....37

4.7.3 TEST PROCEDURES37

4.7.4 TEST RESULTS38

5 INFORMATION ON THE TESTING LABORATORIES.....40

6 APPENDIX A – MODIFICATIONS RECORDERS FOR ENGINEERING CHANGES TO THE EUT BY THE LAB41



BUREAU
VERITAS

Test Report No.: RF170118W005-4

RELEASE CONTROL RECORD

ISSUE NO.	REASON FOR CHANGE	DATE ISSUED
RF170118W005-4	Original release	Mar. 02, 2017

Bureau Veritas Shenzhen Co., Ltd.
Dongguan Branch

No. 34, Chenwulu Section, Guantai Rd.,
Houjie Town, Dongguan City,
Guangdong 523942, China

Tel: +86 769 8593 5656
Fax: +86 769 8593 1080
Email: customerservice.dg@cn.bureauveritas.com



1 CERTIFICATION

PRODUCT: smartphone

BRAND NAME: LANIX

MODEL NAME: Ilium X120

APPLICANT: Corporativo Lanix S.A.de C.V.

TESTED: Feb. 03, 2017 ~ Mar. 01, 2017

TEST SAMPLE: Identical Prototype

STANDARDS: FCC Part 24, Subpart E
ANSI/TIA/EIA-603-D

The above equipment has been tested by **Bureau Veritas Shenzhen Co., Ltd. Dongguan Branch**, and found compliance with the requirement of the above standards. The test record, data evaluation & Equipment Under Test (EUT) configurations represented herein are true and accurate accounts of the measurements of the sample's EMC characteristics under the conditions specified in this report.

PREPARED BY : _____ , **DATE:** Mar. 02, 2017
(Harry Li/ Engineer)

APPROVED BY : _____ , **DATE:** Mar. 02, 2017
(Sam Tung / Manager)



2 SUMMARY OF TEST RESULTS

The EUT has been tested according to the following specifications:

APPLIED STANDARD: FCC Part 24 & Part 2			
STANDARD SECTION	TEST TYPE	RESULT	REMARK
2.1046 24.232	Equivalent Isotropic Radiated Power	PASS	Meet the requirement of limit.
2.1055 24.235	Frequency Stability	PASS	Meet the requirement of limit.
2.1049 24.238(b)	Occupied Bandwidth	PASS	Meet the requirement of limit.
24.232(d)	Peak to average ratio	PASS	Meet the requirement of limit.
24.238(b)	Band Edge Measurements	PASS	Meet the requirement of limit.
2.1051 24.238	Conducted Spurious Emissions	PASS	Meet the requirement of limit.
2.1053 24.238	Radiated Spurious Emissions	PASS	Meet the requirement of limit. Minimum passing margin is -4.81dB at 37.76MHz.

2.1 MEASUREMENT UNCERTAINTY

Where relevant, the following measurement uncertainty levels have been estimated for tests performed on the EUT as specified in CISPR 16-4-2:

MEASUREMENT	FREQUENCY	UNCERTAINTY
Conducted emissions	9kHz~30MHz	2.70dB
Radiated emissions	9KHz ~ 30MHz	2.90dB
	30MHz ~ 1GHz	4.06dB
	1GHz ~ 18GHz	4.58dB
	18GHz ~ 40GHz	1.94dB

This uncertainty represents an expanded uncertainty expressed at approximately the 95% confidence level using a coverage factor of k=2.



2.2 TEST SITE AND INSTRUMENTS

Equipment	Manufacturer	Model No.	Serial No.	Last Cal.	Next Cal.
EMI Test Receiver	Rohde&Schwarz	ESR7	101494	Apr. 05,16	Apr. 04,17
Signal and Spectrum Analyzer	Rohde&Schwarz	FSV7	102331	Nov. 04,16	Nov. 03,17
Signal and Spectrum Analyzer	Rohde&Schwarz	FSV40	101094	Apr. 05,16	Apr. 04,17
Bilog Antenna 1	Teseq	CBL 6111D	30643	Jul. 14, 16	Jul. 13, 17
Bilog Antenna 2	Teseq	CBL 6111D	27089	Jul. 14, 16	Jul. 13, 17
Loop antenna	Daze	ZN30900A	0708	Nov. 28, 16	Nov. 27, 17
Horn Antenna (1GHz -18GHz)	ETS -Lindgren	3117	00062558	May 18,16	May 17,17
Horn Antenna (1GHz -18GHz)	ETS -Lindgren	3117	00062557	May 18,16	May 17,17
10m Semi-anechoic Chamber	CHANGLING	21.4m*12.1m*8.8m	NSEMC006	Mar. 12,16	Mar. 11,18
Test Software	E3	V 9.160323	N/A	N/A	N/A
Test Software	ADT	ADT_Radiated V7.6.15.9.2	N/A	N/A	N/A
10dB Attenuator	JFW/USA	50HF-010-SMA	1505	Jul. 27, 16	Jul. 26, 17
Horn Antenna (15GHz-40GHz)	SCHWARZBECK	BBHA 9170	BBHA9170147	Mar. 12,16	Mar. 11,17
Horn Antenna (15GHz-40GHz)	SCHWARZBECK	BBHA 9170	BBHA9170242	Mar. 12,16	Mar. 11,17
Amplifier	Burgeon	BPA-530	100220	Apr. 05,16	Apr. 04,17
Amplifier (9kHz-1GHz)	SONOMA	310D	186955	Feb. 10,17	Feb. 09,18
Pre-Amplifier(1-18G)	HP	8449B	3008A00409	Apr. 25,16	Apr. 24,17
Pre-Amplifier (18GHz-40GHz)	EMCI	EMC 184045	980102	Nov. 04,16	Nov. 03,17
Humid & Temp Programmable Tester	Haida	HD-2257	110807201	Sep.05,16	Sep. 04,17
Signal Generator	Agilent	N5183A	MY50140980	Nov. 04,16	Nov. 03,17

- NOTE:**
1. The calibration interval of the above test instruments is 12 months or 24 months and the calibrations are traceable to CEPREI/CHINA, GRGT/CHINA and NIM/CHINA.
 2. The test was performed in 10m Semi-anechoic Chamber and RF Oven Room.
 3. The horn antenna is used only for the measurement of emission frequency above 1GHz if tested.
 4. The FCC Site Registration No. is 502831.



3 GENERAL INFORMATION

3.1 GENERAL DESCRIPTION OF EUT

PRODUCT	smartphone	
BRAND NAME	LANIX	
MODEL NAME	Ilium X120	
POWER SUPPLY	5.0Vdc (adapter or host equipment) 3.8Vdc (Li-ion, battery)	
MODULATION TYPE	GSM, GPRS	GMSK
	WCDMA	BPSK
FREQUENCY RANGE	GSM, GPRS	1850.2MHz ~ 1909.8MHz
	WCDMA	1852.4MHz ~ 1907.6MHz
MAX. EIRP POWER	GSM	1012mW
	WCDMA	247mW
EMISSION DESIGNATOR	GSM	246KGXW
	WCDMA	4M18F9W
ANTENNA TYPE	Fixed Internal antenna with 1dBi gain	
HW VERSION	1.0	
SW VERSION	ILIUUM X120_TECCEL_SW_01	
I/O PORTS	Refer to user's manual	
CABLE SUPPLIED	USB cable: non-shielded, detachable, 1.0m Earphone cable: non-shielded, detachable, 1.0m	

NOTE:

- For a more detailed features description, please refer to the manufacturer's specifications or the user's manual.
- The EUT was powered by the following adapter:

ADAPTER	
BRAND:	LANIX
MODEL:	Ilium X120-C
INPUT:	AC 100-240V, 150mA
OUTPUT:	DC 5V, 500mA

- The EUT matched the following USB cable and Earphone:

USB CABLE	
BRAND:	LANIX
MODEL:	Ilium X120
SIGNAL LINE:	1.0 METER



EARPHONE	
BRAND:	LANIX
MODEL:	Ilium X120
SIGNAL LINE:	1.0 METER

4. For the test results, the EUT had been tested with all conditions. But only the worst case was shown in test report.



3.2 CONFIGURATION OF SYSTEM UNDER TEST

FOR RADIATION EMISSION

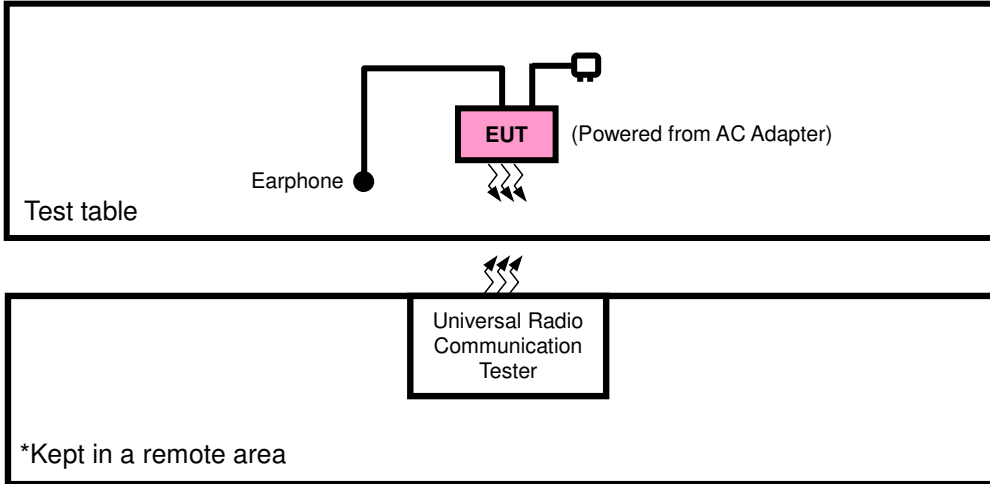

FOR CONDUCTED & E.I.R.P. TEST

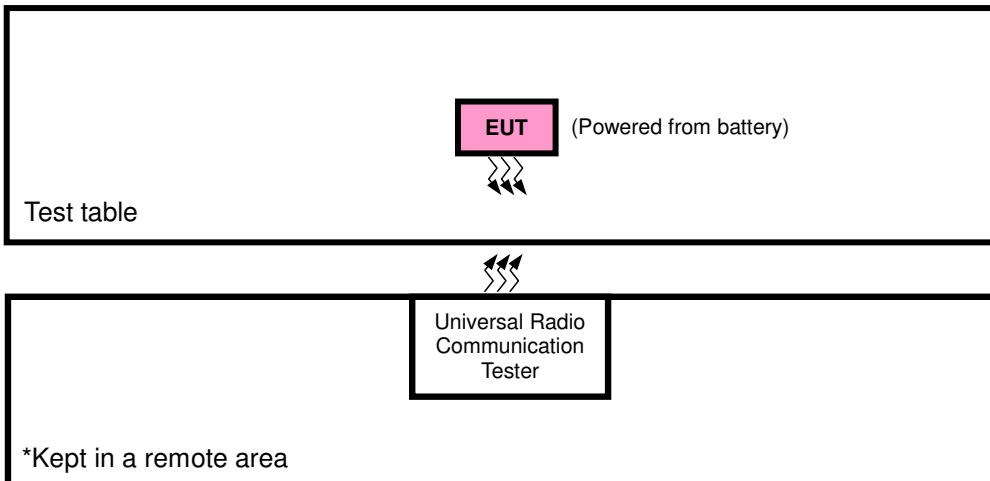



3.3 DESCRIPTION OF SUPPORT UNITS

The EUT has been tested as an independent unit together with other necessary accessories or support units. The following support units or accessories were used to form a representative test configuration during the tests.

NO.	PRODUCT	BRAND	MODEL NO.	SERIAL NO.	FCC ID
1	DC source	LONG WEI	PS-6403D	010934269	N/A
2	PC	HP	A6608CN	3CR83825X3	N/A

NO.	SIGNAL CABLE DESCRIPTION OF THE ABOVE SUPPORT UNITS
1	DC Line: Unshielded, Detachable 1.0m
2	AC Line: Unshielded, Detachable 1.5m

NOTE:

- All power cords of the above support units are non shielded (1.8m).

3.4 TEST ITEM AND TEST CONFIGURATION

Pre-Scan has been conducted to determine the worst-case mode from all possible combinations between available modulations, data rates, XYZ axis and antenna ports

The worst case in EIRP and radiated emission was found when positioned on X-plane for GSM/EDGE/WCDMA. Following channel(s) was (were) selected for the final test as listed below:

EUT CONFIGURE MODE	DESCRIPTION
A	EUT + Adapter + USB Cable + Earphone with GSM ,WCDMA
B	EUT + Battery+ USB Cable + Earphone with GSM ,WCDMA

GSM MODE

EUT CONFIGURE MODE	TEST ITEM	AVAILABLE CHANNEL	TESTED CHANNEL	MODE
B	EIRP	512 to 810	512, 661, 810	GSM
B	FREQUENCY STABILITY	512 to 810	512, 661, 810	GSM
B	OCCUPIED BANDWIDTH	512 to 810	512, 661, 810	GSM
B	PEAK TO AVERAGE RATIO	512 to 810	661	GSM
B	BAND EDGE	512 to 810	512, 810	GSM
B	CONDCUDETED EMISSION	512 to 810	661	GSM
A	RADIATED EMISSION	512 to 810	661	GSM



WCDMA MODE

EUT CONFIGURE MODE	TEST ITEM	AVAILABLE CHANNEL	TESTED CHANNEL	MODE
B	EIRP	9262 to 9538	9262, 9400, 9538	WCDMA
B	FREQUENCY STABILITY	9262 to 9538	9262, 9400, 9538	WCDMA
B	OCCUPIED BANDWIDTH	9262 to 9538	9262, 9400, 9538	WCDMA
B	PEAK TO AVERAGE RATIO	9262 to 9538	9400	WCDMA
B	BAND EDGE	9262 to 9538	9262, 9538	WCDMA
B	CONDCUDED EMISSION	9262 to 9538	9400	WCDMA
A	RADIATED EMISSION	9262 to 9538	9400	WCDMA

TEST CONDITION:

TEST ITEM	ENVIRONMENTAL CONDITIONS	INPUT POWER	TESTED BY
EIRP	25deg. C, 57%RH	3.8Vdc from Battery	Wenliang Wu
FREQUENCY STABILITY	23deg. C, 61%RH	3.8Vdc from Battery	Wenliang Wu
OCCUPIED BANDWIDTH	23deg. C, 61%RH	3.8Vdc from Battery	Wenliang Wu
PEAK TO AVERAGE RATIO	23deg. C, 61%RH	3.8Vdc from Battery	Moon Xiong
BAND EDGE	23deg. C, 61%RH	3.8Vdc from Battery	Moon Xiong
CONDCUDED EMISSION	23deg. C, 61%RH	3.8Vdc from Battery	Moon Xiong
RADIATED EMISSION	26deg. C, 56%RH	5Vdc from adapter	Tony Zou



3.5 EUT OPERATING CONDITIONS

The EUT makes a call to the communication simulator. The communication simulator station system controlled a EUT to export maximum output power under transmission mode and specific channel frequency

3.6 GENERAL DESCRIPTION OF APPLIED STANDARDS

The EUT is a RF product. According to the specifications of the manufacturer, it must comply with the requirements of the following standards:

FCC 47 CFR Part 2

FCC 47 CFR Part 24

KDB 971168 D01 Power Meas License Digital Systems v02r02

ANSI/TIA/EIA-603-D

NOTE: All test items have been performed and recorded as per the above standards.



4 TEST TYPES AND RESULTS

4.1 OUTPUT POWER MEASUREMENT

4.1.1 LIMITS OF OUTPUT POWER MEASUREMENT

Mobile and portable stations are limited to 2 watts EIRP.

4.1.2 TEST PROCEDURES

EIRP MEASUREMENT:

- a. All measurements were done at low, middle and high operational frequency range. RBW and VBW is 1MHz for GSM & GPRS, and 5MHz for WCDMA mode.
- b. Substitution method is used for E.I.R.P measurement. In the semi-anechoic chamber, EUT placed on the 0.8m height of Turn Table, rotated the table around 360 degrees to search the maximum radiation power and receiver antenna shall be rotated vertical and horizontal polarization and moved height from 1m to 4m to find the maximum polar radiated power. The “Read Value” is the spectrum reading the maximum power value.
- c. The substitution horn antenna is substituted for EUT at the same position and signals generator export the CW signal to the substitution antenna via a tx cable. Rotated the Turn Table and moved receiving antenna to find the maximum radiation power. Adjust output power level of S.G to get a Value of spectrum reading equal to “Read Value” of step b. Record the power level of S.G
- d. $EIRP = \text{Output power level of S.G} - \text{TX cable loss} + \text{Antenna gain of substitution horn.}$

CONDUCTED POWER MEASUREMENT:

The EUT was set up for the maximum power with GSM, GPRS & WCDMA link data modulation and link up with simulator. Set the EUT to transmit under low, middle and high channel and record the power level shown on simulator.



4.1.3 TEST SETUP

EIRP MEASUREMENT:

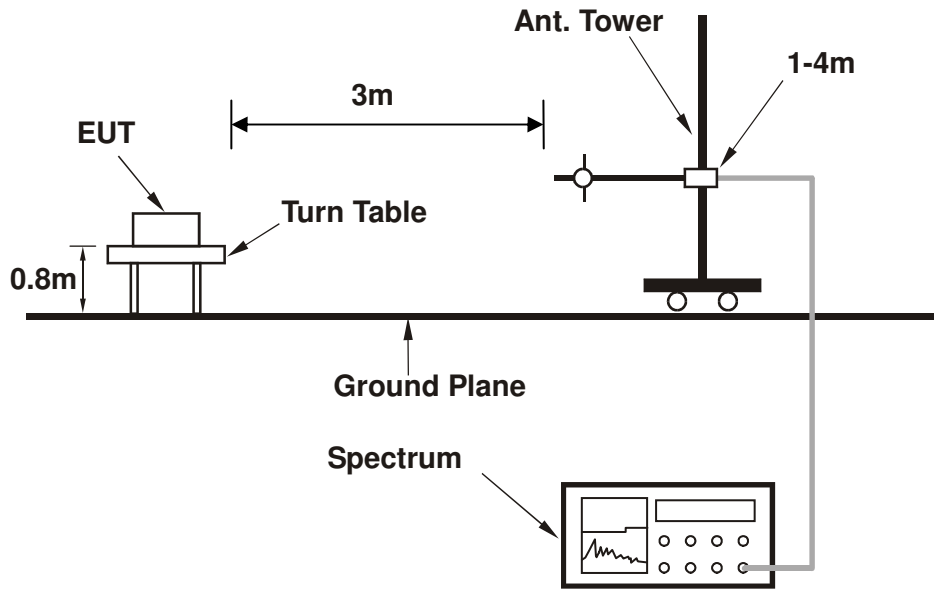

For the actual test configuration, please refer to the attached file (Test Setup Photo).

CONDUCTED POWER MEASUREMENT:

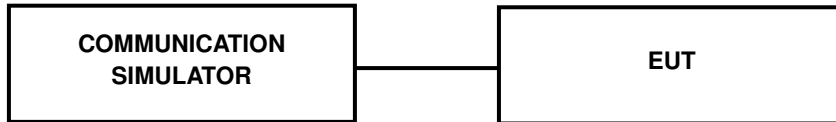

For the actual test configuration, please refer to the attached file (Test Setup Photo).



4.1.4 TEST RESULTS

CONDUCTED OUTPUT POWER (dBm)

Band	GSM1900		
Channel	512	661	810
Frequency (MHz)	1850.2	1880.0	1909.8
GSM	27.63	27.67	27.92
GPRS 8	27.62	27.66	27.91
GPRS 10	27.59	27.63	27.88
GPRS 11	25.84	25.88	26.13
GPRS 12	23.79	23.83	24.08

Band	WCDMA II		
Channel	9262	9400	9538
Frequency (MHz)	1852.4	1880.0	1907.6
RMC 12.2K	20.32	20.48	20.46
HSPA			
HSDPA Subtest-1	19.33	19.49	19.47
HSDPA Subtest-2	19.30	19.46	19.44
HSDPA Subtest-3	18.80	18.96	18.94
HSDPA Subtest-4	18.76	18.92	18.90
HSUPA Subtest-1	19.33	19.49	19.47
HSUPA Subtest-2	17.29	17.45	17.43
HSUPA Subtest-3	18.31	18.47	18.45
HSUPA Subtest-4	17.26	17.42	17.40
HSUPA Subtest-5	19.33	19.49	19.47



EIRP POWER (dBm)

GSM

Channel	Frequency (MHz)	SPA LVL (dBm)	Correction Factor(dB)	EIRP(dBm)	EIRP(mW)	Polarization (H/V)
512	1850.2	-20.43	43.83	23.40	218.78	H
661	1880.0	-19.90	43.57	23.67	232.81	H
810	1909.8	-20.72	44.57	23.85	242.66	H
512	1850.2	-16.34	46.39	30.05	1011.58	V
661	1880.0	-17.23	47.10	29.87	970.06	V
810	1909.8	-18.05	45.98	27.93	620.30	V

REMARKS: 1. EIRP Output Power (dBm) = SPA LVL (dBm) + Correction Factor (dB).
2. Correction factor (dB) = Free Space Loss + Antenna Factor + Cable Loss

WCDMA

Channel	Frequency (MHz)	SPA LVL (dBm)	Correction Factor(dB)	EIRP(dBm)	EIRP(mW)	Polarization (H/V)
9262	1852.4	-26.12	43.83	17.71	59.02	H
9400	1880.0	-25.54	43.57	18.03	63.53	H
9538	1907.6	-26.48	44.57	18.09	64.42	H
9262	1852.4	-22.62	46.39	23.77	238.23	V
9400	1880.0	-23.17	47.10	23.93	247.06	V
9538	1907.6	-24.12	45.98	21.86	153.32	V

REMARKS: 1. EIRP Output Power (dBm) = SPA LVL (dBm) + Correction Factor (dB).
2. Correction factor (dB) = Free Space Loss + Antenna Factor + Cable Loss



4.2 FREQUENCY STABILITY MEASUREMENT

4.2.1 LIMITS OF FREQUENCY STABILITY MEASUREMENT

The frequency stability shall be sufficient to ensure that the fundamental emission stays within the authorized frequency block.

4.2.2 TEST PROCEDURE

- a. Device is placed at the oven room. The oven room could control the temperatures and humidity. Power warm up is at least 15 min and power applied should perform before recording frequency error.
- b. EUT is connected the external power supply to control the DC input power. The test voltage range is from minimum to maximum working voltage. Each step shall be record the frequency error rate.
- c. The temperature range step is 10 degrees in this test items. All temperature levels shall be hold the $\pm 0.5^{\circ}\text{C}$ during the measurement testing. The each temperature step shall be at least 0.5 hours, consider the EUT could be test under the stability condition.

NOTE: The frequency error was recorded frequency error from the communication simulator.

4.2.3 TEST SETUP

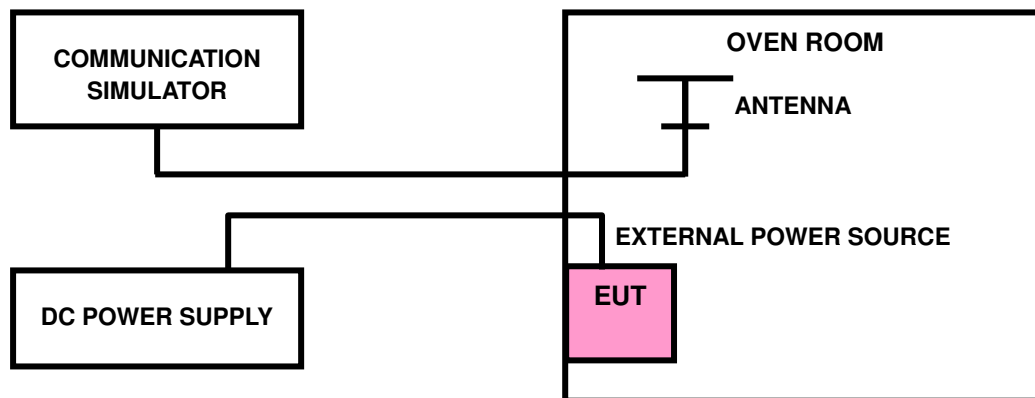



4.2.4 TEST RESULTS

GSM 1900

FREQUENCY ERROR VS. VOLTAGE

VOLTAGE (Volts)	FREQUENCY ERROR (ppm)			LIMIT (ppm)
	Low Channel	Middle Channel	High Channel	
3.8	0.0032	0.0036	0.0026	2.5
3.5	-0.0037	-0.0044	-0.0036	2.5
4.2	-0.0035	-0.0040	-0.0032	2.5

NOTE: The applicant defined the normal working voltage of the battery is from 3.5Vdc to 4.2Vdc.

FREQUENCY ERROR vs. TEMPERATURE.

TEMP. (°C)	FREQUENCY ERROR (ppm)			LIMIT (ppm)
	Low Channel	Middle Channel	High Channel	
-30	-0.0147	-0.0126	-0.0120	2.5
-20	-0.0131	-0.0112	-0.0105	2.5
-10	-0.0114	-0.0097	-0.0090	2.5
0	-0.0098	-0.0083	-0.0072	2.5
10	-0.0083	-0.0066	-0.0057	2.5
20	-0.0066	-0.0049	-0.0044	2.5
30	-0.0052	-0.0037	-0.0030	2.5
40	-0.0038	-0.0023	-0.0016	2.5
50	-0.0022	-0.0008	-0.0001	2.5
60	-0.0004	0.0007	0.0011	2.5



WCDMA II

FREQUENCY ERROR VS. VOLTAGE

VOLTAGE (Volts)	FREQUENCY ERROR (ppm)			LIMIT (ppm)
	Low Channel	Middle Channel	High Channel	
3.8	0.0023	0.0030	0.0022	2.5
3.5	-0.0028	-0.0037	-0.0030	2.5
4.2	-0.0030	-0.0034	-0.0025	2.5

NOTE: The applicant defined the normal working voltage of the battery is from 3.5Vdc to 4.2Vdc.

FREQUENCY ERROR vs. TEMPERATURE.

TEMP. (°C)	FREQUENCY ERROR (ppm)			LIMIT (ppm)
	Low Channel	Middle Channel	High Channel	
-30	-0.0136	-0.0127	-0.0134	2.5
-20	-0.0122	-0.0114	-0.0120	2.5
-10	-0.0106	-0.0101	-0.0102	2.5
0	-0.0089	-0.0086	-0.0084	2.5
10	-0.0073	-0.0073	-0.0070	2.5
20	-0.0055	-0.0058	-0.0052	2.5
30	-0.0040	-0.0044	-0.0037	2.5
40	-0.0025	-0.0031	-0.0024	2.5
50	-0.0011	-0.0015	-0.0012	2.5
60	0.0007	0.0001	0.0004	2.5



4.3 OCCUPIED BANDWIDTH MEASUREMENT

4.3.1 TEST PROCEDURES

The EUT makes a call to the communication simulator. All measurements were done at low, middle and high operational frequency range. The communication simulator station system controlled a EUT to export maximum output power under transmission mode and specific channel frequency. Use OBW measurement function of Spectrum analyzer to measure 99 % occupied bandwidth.

4.3.2 TEST SETUP

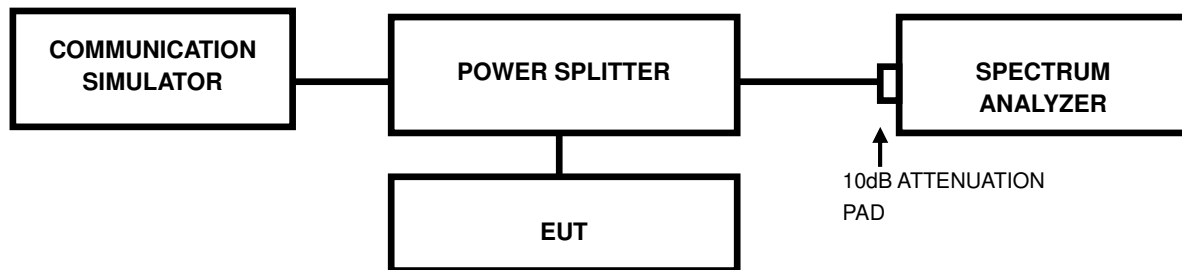



4.3.3 TEST RESULTS

CHANNEL	FREQUENCY (MHz)	99% OCCUPIED BANDWIDTH (kHz)	CHANNEL	FREQUENCY (MHz)	99% OCCUPIED BANDWIDTH (MHz)
		GSM			WCDMA
512	1850.2	245.00	9262	1852.4	4.16
661	1880.0	243.00	9400	1880.0	4.18
810	1909.8	246.00	9538	1907.6	4.16

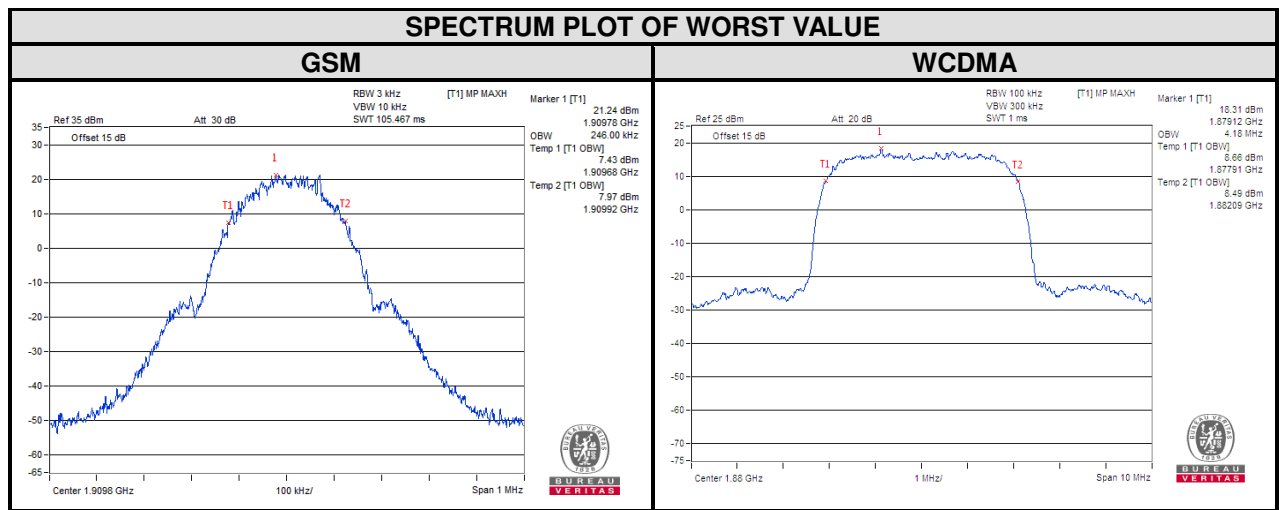



**BUREAU
VERITAS**

Test Report No.: RF170118W005-4

CHANNEL	FREQUENCY (MHz)	26dB BANDWIDTH (kHz)	CHANNEL	FREQUENCY (MHz)	26dB BANDWIDTH (MHz)
		GSM			WCDMA
512	1850.2	321.45	9262	1852.4	4.69
661	1880.0	319.74	9400	1880.0	4.71
810	1909.8	321.13	9538	1907.6	4.71

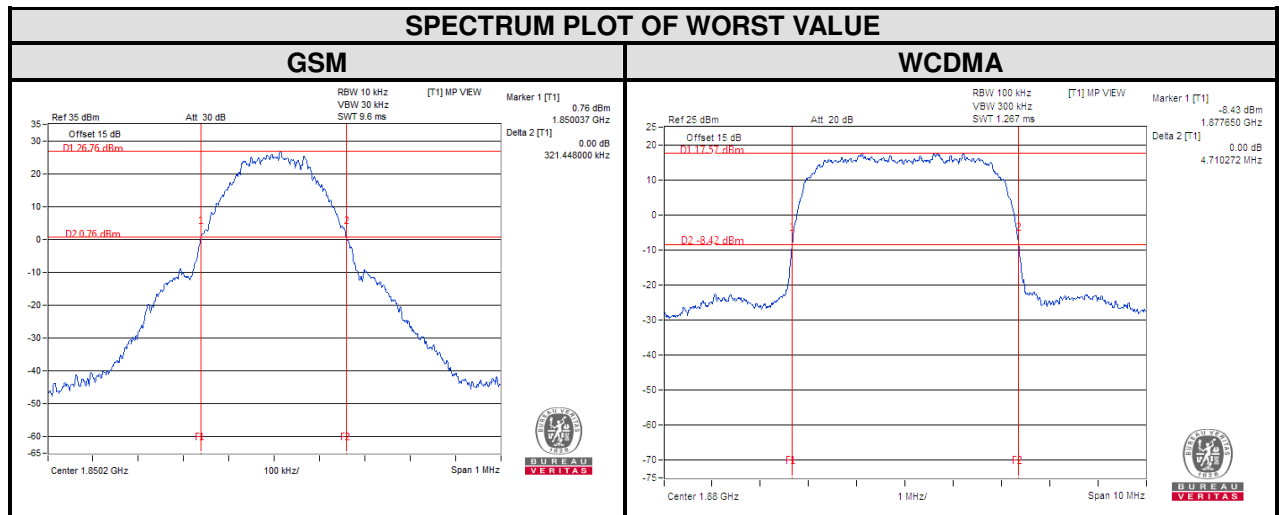

Bureau Veritas Shenzhen Co., Ltd.
Dongguan Branch

No. 34, Chenwulu Section, Guantai Rd.,
Houjie Town, Dongguan City,
Guangdong 523942, China

Tel: +86 769 8593 5656
Fax: +86 769 8593 1080
Email: customerservice.dg@cn.bureauveritas.com



4.4 BAND EDGE MEASUREMENT

4.4.1 LIMITS OF BAND EDGE MEASUREMENT

Power of any emission outside of the authorized operating frequency ranges must be attenuated below the transmitting power (P) by a factor of at least $43 + 10 \log(P)$ dB. In the 1 MHz bands immediately outside and adjacent to the frequency block a resolution bandwidth of at least one percent of the emission bandwidth of the fundamental emission of the transmitter may be employed.

4.4.2 TEST SETUP

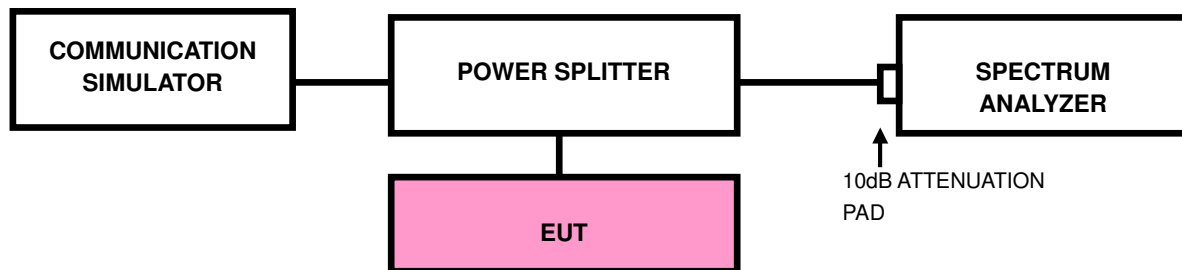

4.4.3 TEST PROCEDURES

- All measurements were done at low and high operational frequency range.
- The center frequency of spectrum is the band edge frequency and span is 1.5 MHz. RBW of the spectrum is 10kHz and VBW of the spectrum is 30kHz (GSM/GPRS).
- The center frequency of spectrum is the band edge frequency and span is 10MHz. RBW of the spectrum is 100kHz and VB of the spectrum is 300kHz (WCDMA).
- Record the max trace plot into the test report.



4.4.4. TEST RESULTS

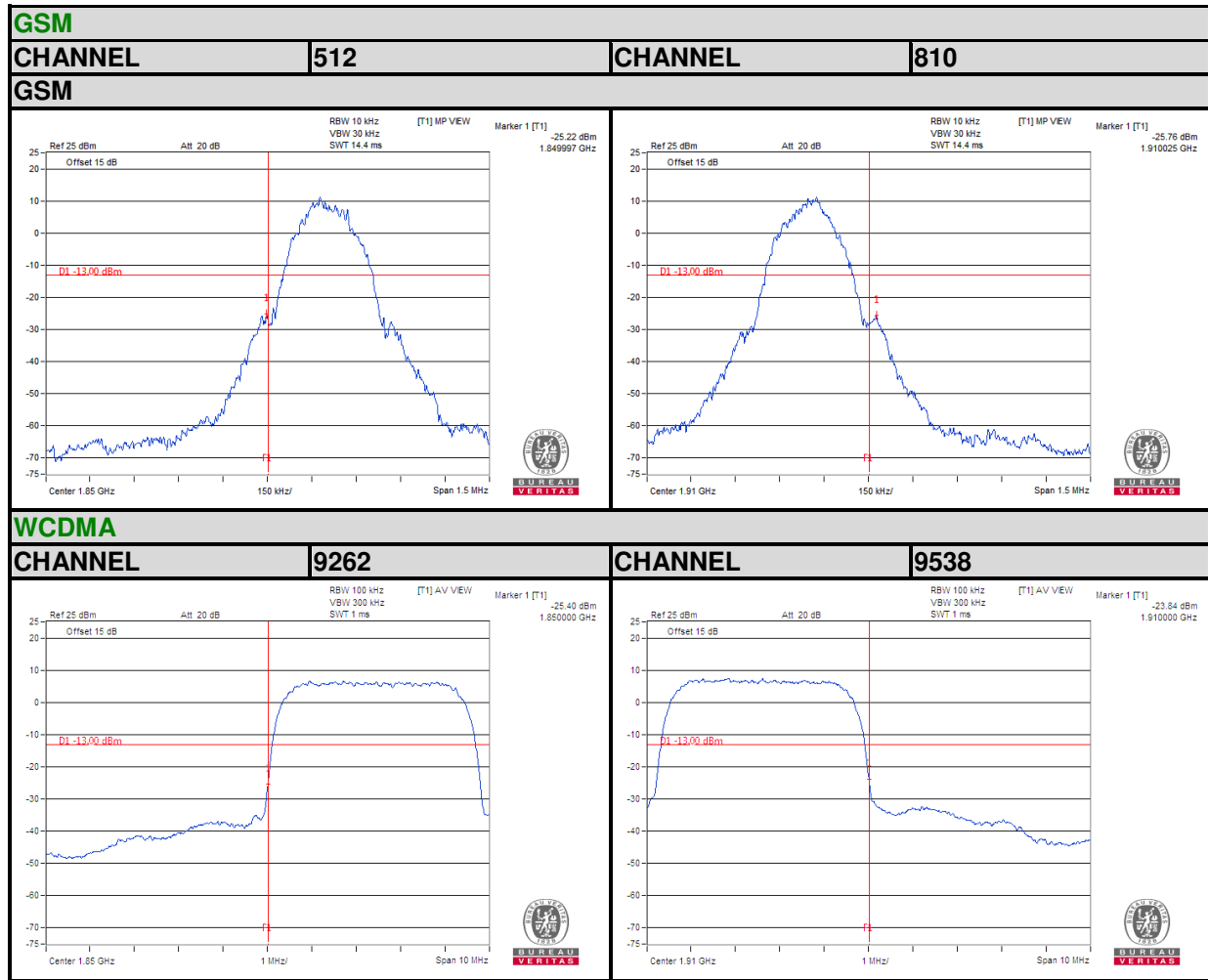



4.5 CONDUCTED SPURIOUS EMISSIONS

4.5.1 LIMITS OF CONDUCTED SPURIOUS EMISSIONS MEASUREMENT

The power of any emission outside of the authorized operating frequency ranges must be attenuated below the transmitting power (P) by a factor of at least $43 + 10 \log(P)$ dB. The emission limit equal to -13dBm .

4.5.2 TEST PROCEDURE

- a. The EUT makes a phone call to the communication simulator. All measurements were done at low, middle and high operational frequency range.
- b. Measuring frequency range is from 9 kHz to 19.1GHz. 20dB attenuation pad is connected with spectrum. RBW=1MHz and VBW=3MHz is used for conducted emission measurement.

4.5.3 TEST SETUP

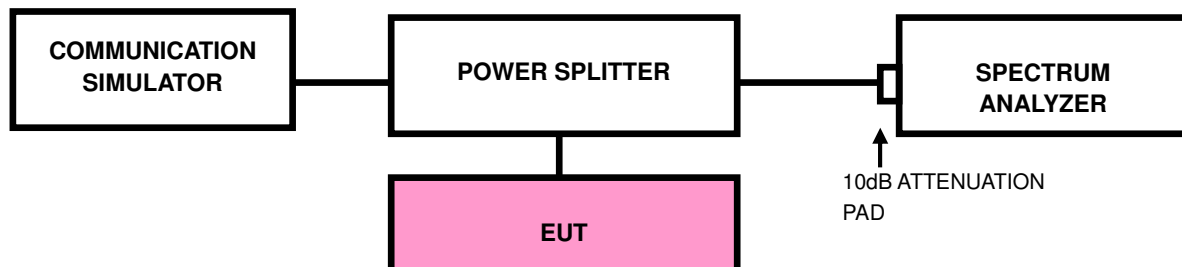



4.5.4 TEST RESULTS

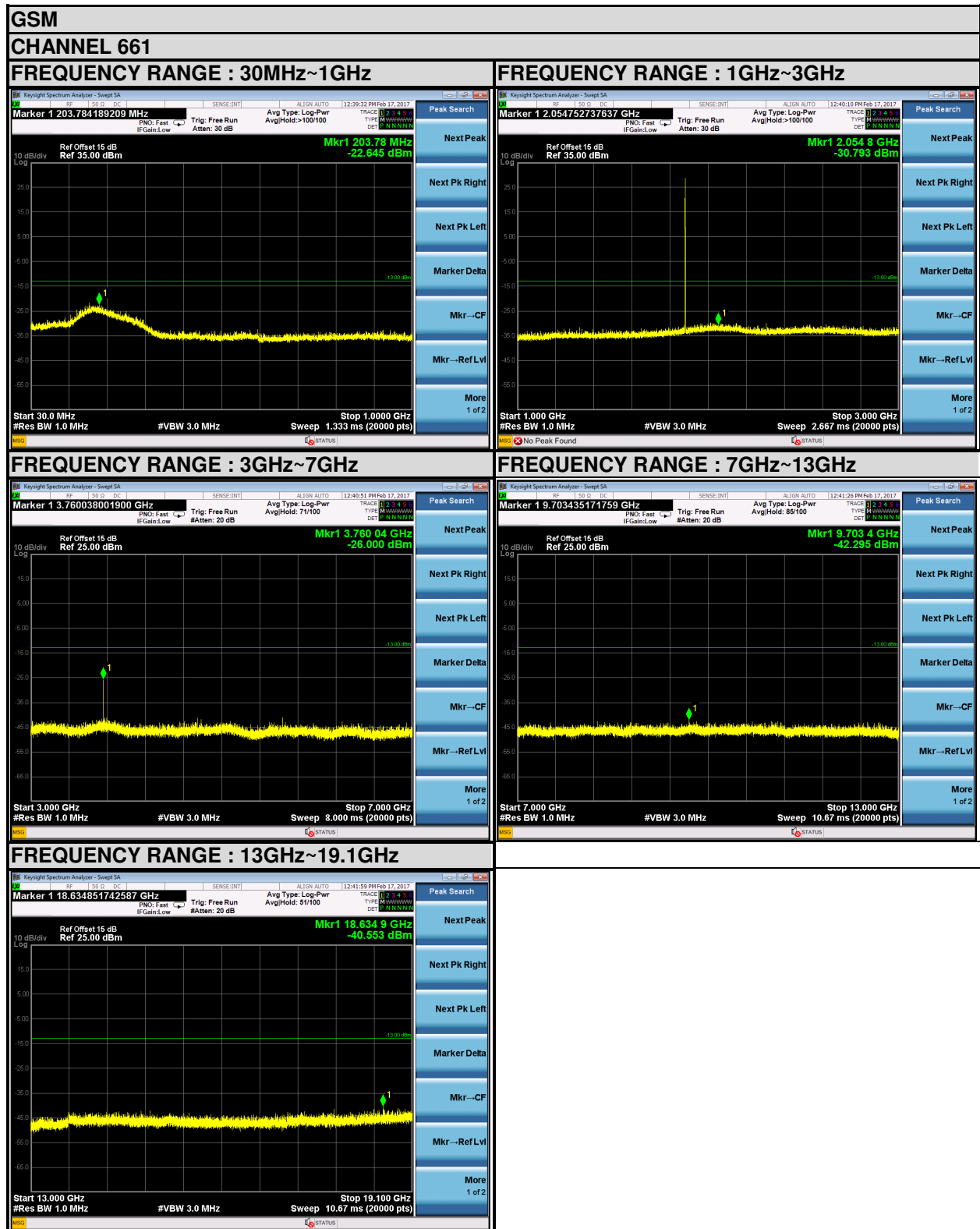



BUREAU VERITAS

Test Report No.: RF170118W005-4

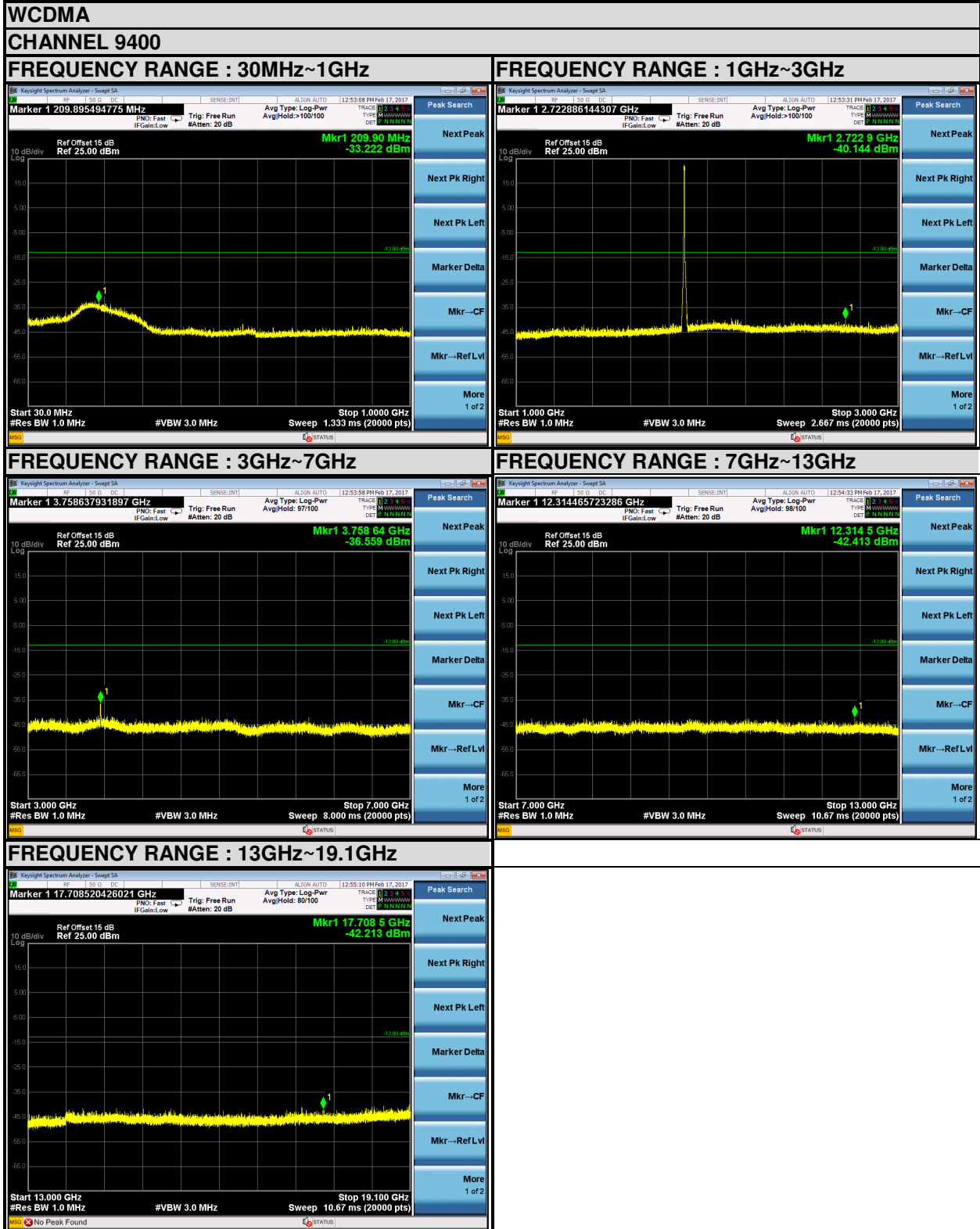

Bureau Veritas Shenzhen Co., Ltd.
Dongguan Branch

No. 34, Chenwulu Section, Guantai Rd.,
Houjie Town, Dongguan City,
Guangdong 523942, China

Tel: +86 769 8593 5656
Fax: +86 769 8593 1080
Email: customerservice.dg@cn.bureauveritas.com



4.6 RADIATED EMISSION MEASUREMENT

4.6.1 LIMITS OF RADIATED EMISSION MEASUREMENT

The power of any emission outside of the authorized operating frequency ranges must be attenuated below the transmitting power (P) by a factor of at least $43 + 10 \log(P)$ dB. The emission limit equal to -13dBm .

4.6.2 TEST PROCEDURES

- a. Substitution method is used for E.I.R.P measurement. In the semi-anechoic chamber, EUT placed on the 0.8m height of Turn Table, rotated the table around 360 degrees to search the maximum radiation power and receiver antenna shall be rotated vertical and horizontal polarization and moved height from 1m to 4m to find the maximum polar radiated power. The “Read Value” is the spectrum reading the maximum power value.
- b. The substitution horn antenna is substituted for EUT at the same position and signals generator export the CW signal to the substitution antenna via a TX cable. Rotated the Turn Table and moved receiving antenna to find the maximum radiation power. Adjust output power level of S.G to get a Value of spectrum reading equal to “Read Value “ of step a. Record the power level of S.G
- c. $\text{EIRP} = \text{Output power level of S.G} - \text{TX cable loss} + \text{Antenna gain of substitution horn}$.

NOTE: The resolution bandwidth and video bandwidth of test receiver/spectrum analyzer is 1MHz/3MHz.

4.6.3 DEVIATION FROM TEST STANDARD

No deviation



4.6.4 TEST SETUP

<Below 30MHz>

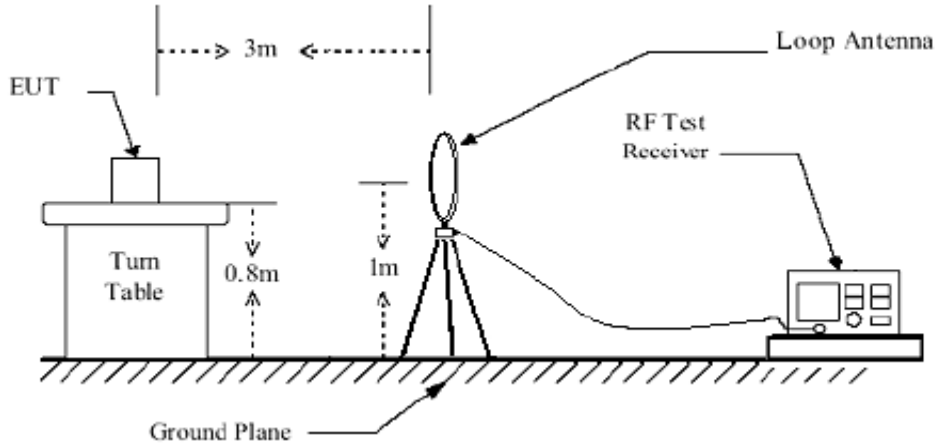

<Above 30MHz>

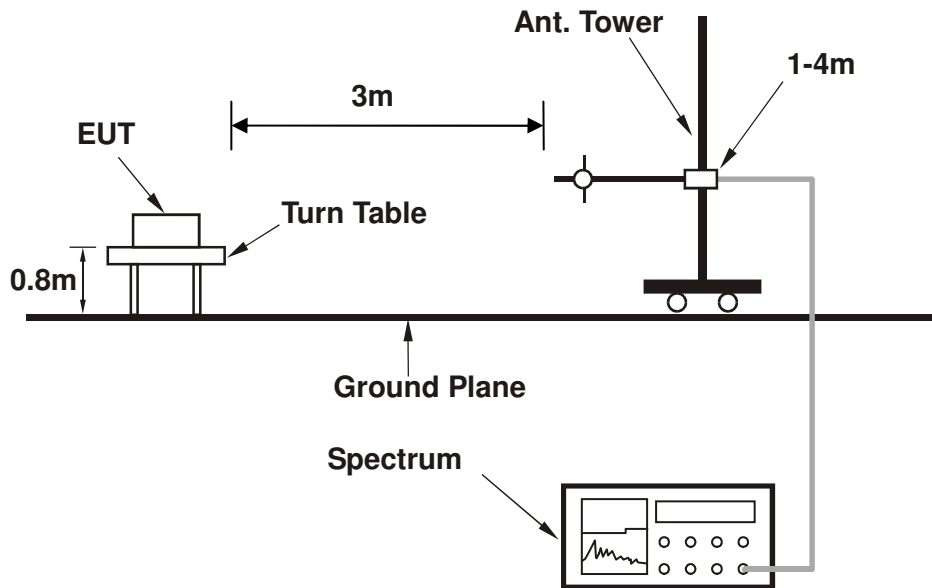

For the actual test configuration, please refer to the attached file (Test Setup Photo).



4.6.5 TEST RESULTS

BELOW 1GHz WORST-CASE DATA

9 KHz – 30 KHz data: the amplitude of spurious emissions attenuated more than 20 dB below the permissible value is not required in the report.

30 MHz – 1GHz data:

PCS 1900:

MODE	TX channel 661	FREQUENCY RANGE	Below 1000MHz
ENVIRONMENTAL CONDITIONS	26deg. C, 56%RH	INPUT POWER	DC 5V from adapter
TESTED BY	Tony Zou		
ANTENNA POLARITY & TEST DISTANCE: HORIZONTAL AT 3 M			

	Freq	Level	Read Level	Limit Line	Over Limit	Factor	Remark	Pol/Phase
	MHz	dBm/m	dBm	dBm/m	dB	dB/m		
1	PP	37.760	-17.81	-30.05	-13.00	-4.81	12.24 Peak	Horizontal
2		83.350	-43.75	-35.64	-13.00	-30.75	-8.11 Peak	Horizontal
3		124.090	-48.40	-32.67	-13.00	-35.40	-15.73 Peak	Horizontal
4		158.040	-60.03	-41.43	-13.00	-47.03	-18.60 Peak	Horizontal
5		241.460	-65.18	-48.74	-13.00	-52.18	-16.44 Peak	Horizontal
6		287.050	-64.83	-50.38	-13.00	-51.83	-14.45 Peak	Horizontal

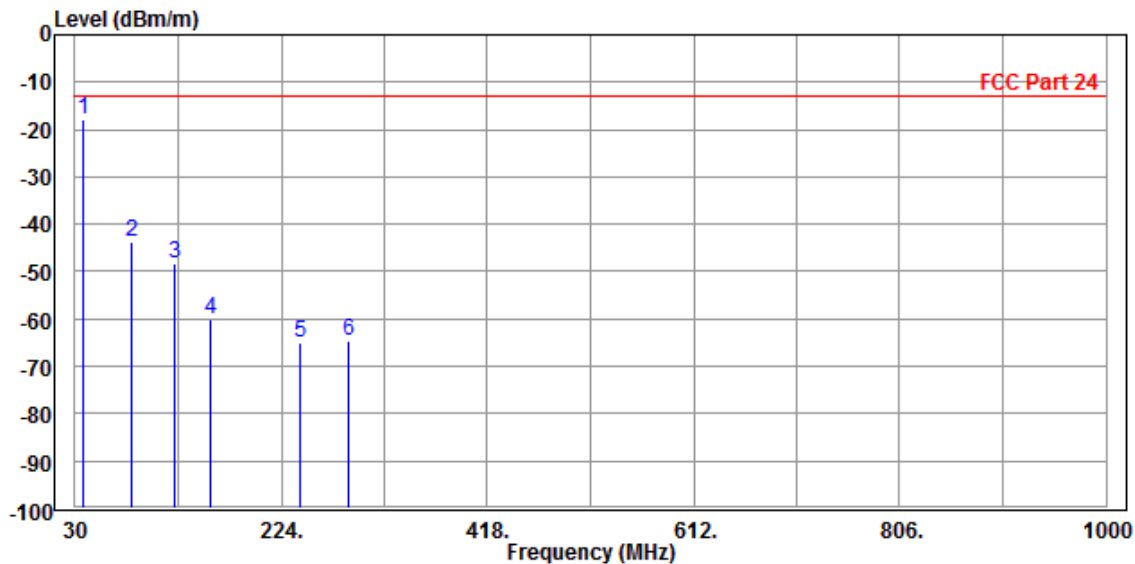



MODE	TX channel 661	FREQUENCY RANGE	Below 1000MHz
ENVIRONMENTAL CONDITIONS	26deg. C, 56%RH	INPUT POWER	DC 5V from adapter
TESTED BY	Tony Zou		
ANTENNA POLARITY & TEST DISTANCE: VERTICAL AT 3 M			

	Freq	Level	Read Level	Limit Line	Over Limit	Factor	Remark	Pol/Phase
	MHz	dBm/m	dBm	dBm/m	dB	dB/m		
1	PP	38.730	-24.79	-23.50	-13.00	-11.79	-1.29 Peak	Vertical
2		83.350	-45.16	-34.82	-13.00	-32.16	-10.34 Peak	Vertical
3		125.060	-45.94	-33.73	-13.00	-32.94	-12.21 Peak	Vertical
4		160.950	-61.30	-46.13	-13.00	-48.30	-15.17 Peak	Vertical
5		234.670	-63.11	-51.86	-13.00	-50.11	-11.25 Peak	Vertical
6		287.050	-71.17	-59.82	-13.00	-58.17	-11.35 Peak	Vertical

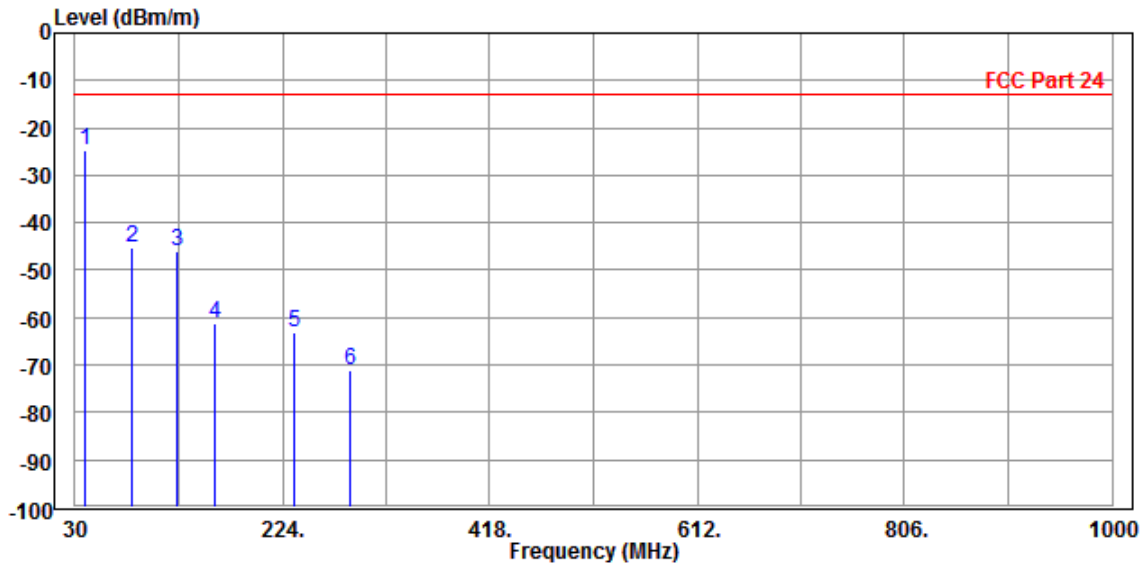



ABOVE 1GHz DATA

Note: For higher frequency, the emission is too low to be detected.

PCS 1900:

MODE	TX channel 661	FREQUENCY RANGE	Above 1000MHz
ENVIRONMENTAL CONDITIONS	26deg. C, 56%RH	INPUT POWER	DC 5V from adapter
TESTED BY	Tony Zou		
ANTENNA POLARITY & TEST DISTANCE: HORIZONTAL AT 3 M			

	Freq	Level	Read Level	Limit	Over Limit	Factor	Remark	Pol/Phase
	MHz	dBm/m	dBm	dBm/m	dB	dB/m		
1	PP 3755.000	-36.85	-40.24	-13.00	-23.85	3.39	Peak	Horizontal
2	5640.000	-40.29	-49.41	-13.00	-27.29	9.12	Peak	Horizontal

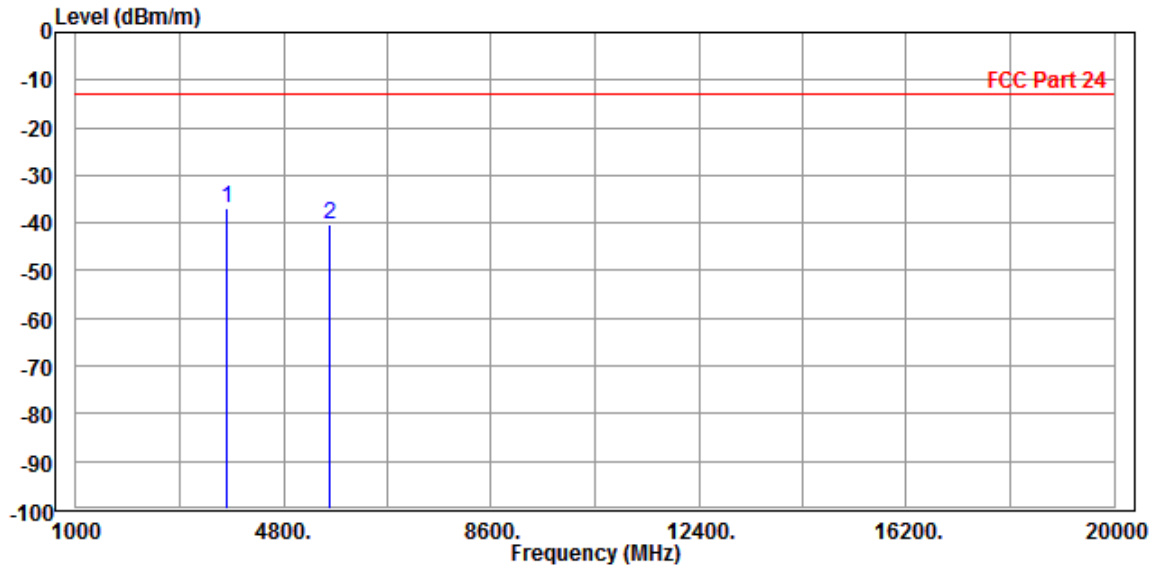



MODE	TX channel 661	FREQUENCY RANGE	Above 1000MHz
ENVIRONMENTAL CONDITIONS	26deg. C, 56%RH	INPUT POWER	DC 5V from adapter
TESTED BY	Tony Zou		
ANTENNA POLARITY & TEST DISTANCE: VERTICAL AT 3 M			

	Freq	Level	Read Level	Limit Line	Over Limit	Factor	Remark	Pol/Phase
	MHz	dBm/m	dBm	dBm/m	dB	dB/m		
1	PP 3755.000	-35.72	-39.57	-13.00	-22.72	3.85	Peak	Vertical
2	5640.000	-43.02	-51.28	-13.00	-30.02	8.26	Peak	Vertical

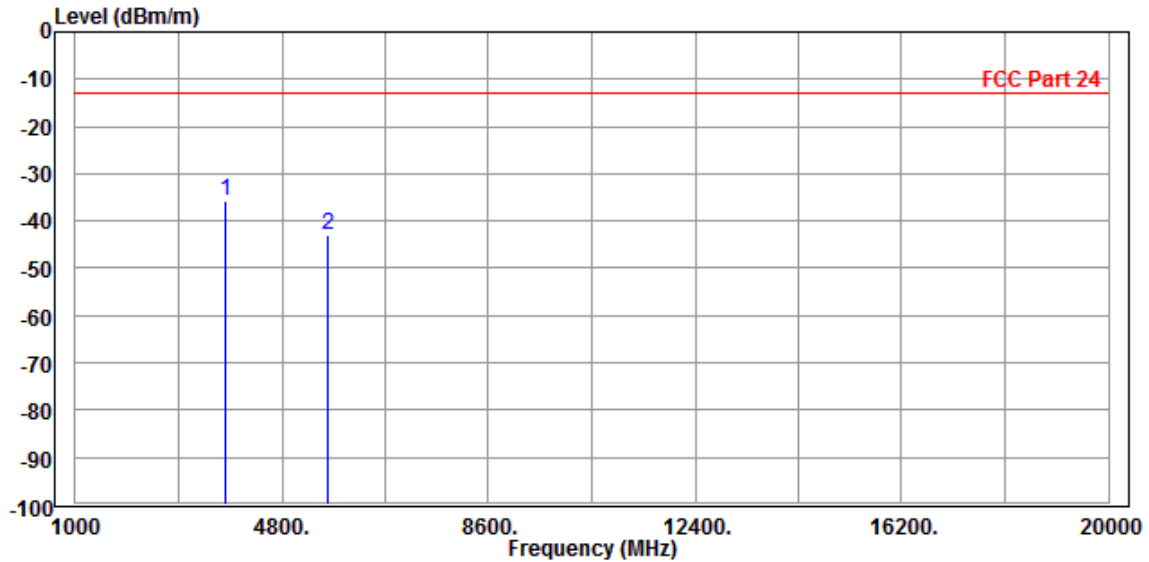



WCDMA Band II:

MODE	TX channel 9400	FREQUENCY RANGE	Above 1000MHz
ENVIRONMENTAL CONDITIONS	26deg. C, 56%RH	INPUT POWER	DC 5V from adapter
TESTED BY	Tony Zou		
ANTENNA POLARITY & TEST DISTANCE: HORIZONTAL AT 3 M			

	Freq	Level	Read Level	Limit Line	Over Limit	Factor	Remark	Pol/Phase
	MHz	dBm/m	dBm	dBm/m	dB	dB/m		
1	PP 3755.000	-43.79	-47.18	-13.00	-30.79	3.39	Peak	Horizontal
2	5640.000	-45.47	-54.59	-13.00	-32.47	9.12	Peak	Horizontal

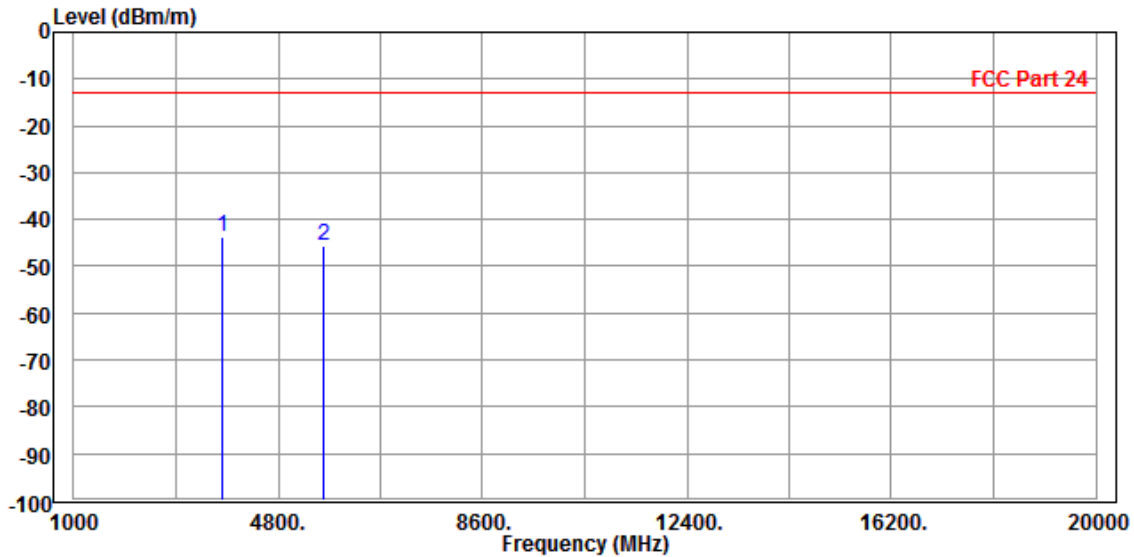



MODE	TX channel 9400	FREQUENCY RANGE	Above 1000MHz
ENVIRONMENTAL CONDITIONS	26deg. C, 56%RH	INPUT POWER	DC 5V from adapter
TESTED BY	Tony Zou		
ANTENNA POLARITY & TEST DISTANCE: VERTICAL AT 3 M			

	Freq	Level	Read Level	Limit Line	Over Limit	Factor	Remark	Pol/Phase
	MHz	dBm/m	dBm	dBm/m	dB	dB/m		
1	PP 3755.000	-45.84	-49.69	-13.00	-32.84	3.85	Peak	Vertical
2	5640.000	-47.37	-55.63	-13.00	-34.37	8.26	Peak	Vertical

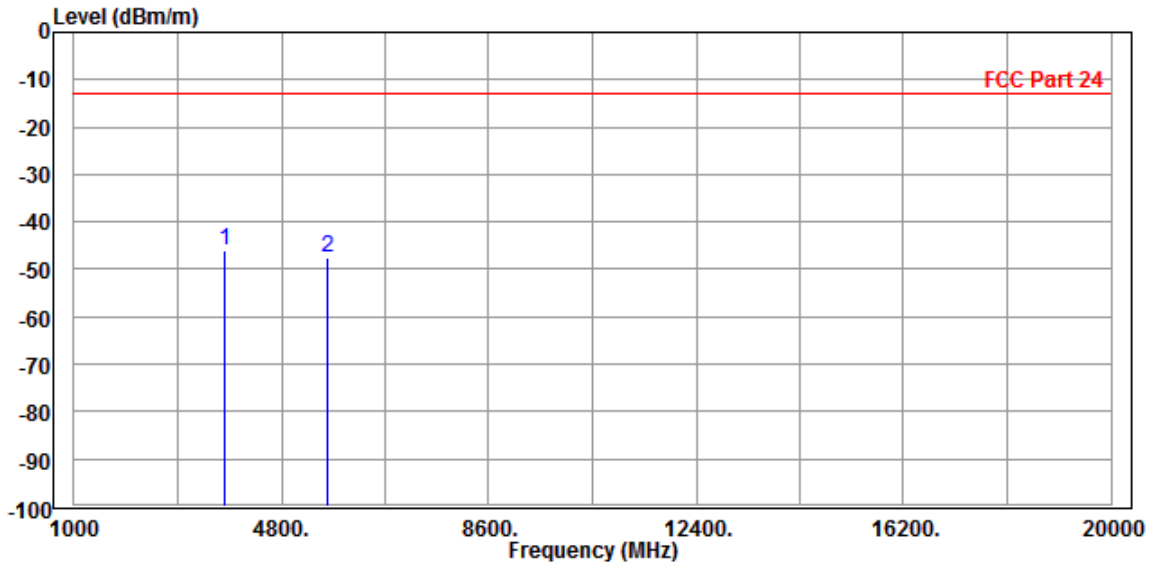



4.7 PEAK TO AVERAGE RATIO

4.7.1 LIMITS OF peak to average ratio MEASUREMENT

In measuring transmissions in this band using an average power technique, the peak to-average ratio (PAR) of the transmission may not exceed 13 dB

4.7.2 TEST SETUP

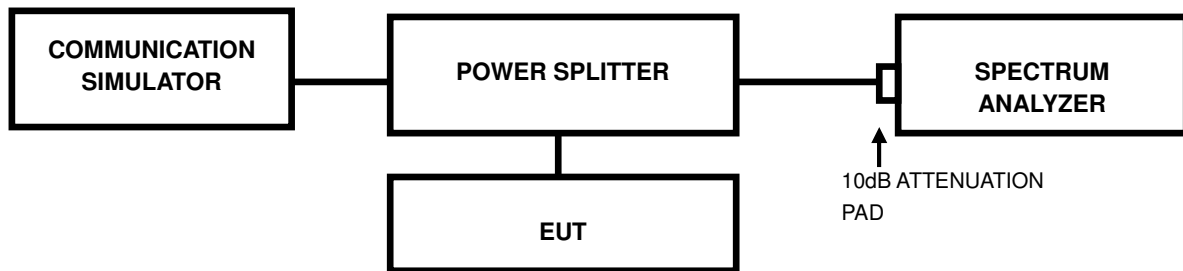

4.7.3 TEST PROCEDURES

1. Set resolution/measurement bandwidth \geq signal's occupied bandwidth;
2. Set the number of counts to a value that stabilizes the measured CCDF curve;
3. Record the maximum PAPR level associated with a probability of 0.1%.



4.7.4 TEST RESULTS

GSM

CHANNEL	FREQUENCY (MHz)	PEAK TO AVERAGE RATIO (dB)
661	1880	2.60

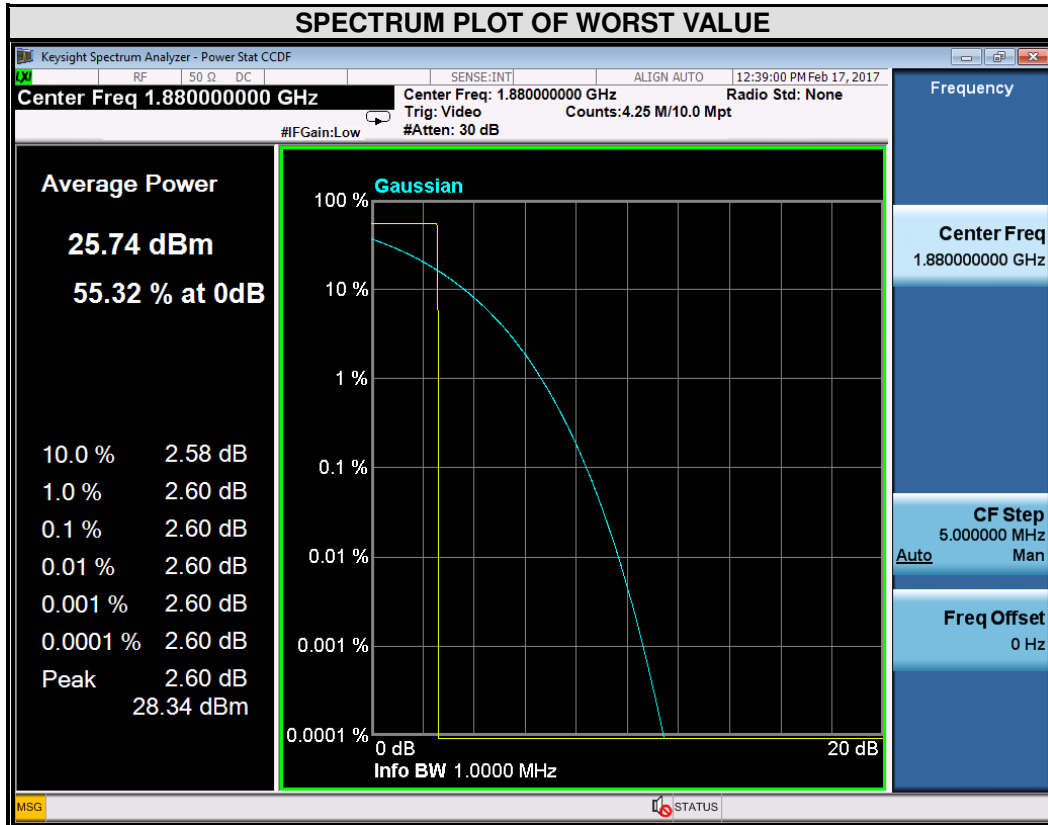



**BUREAU
VERITAS**

Test Report No.: RF170118W005-4

WCDMA

CHANNEL	FREQUENCY (MHz)	PEAK TO AVERAGE RATIO (dB)
9400	1880	2.96

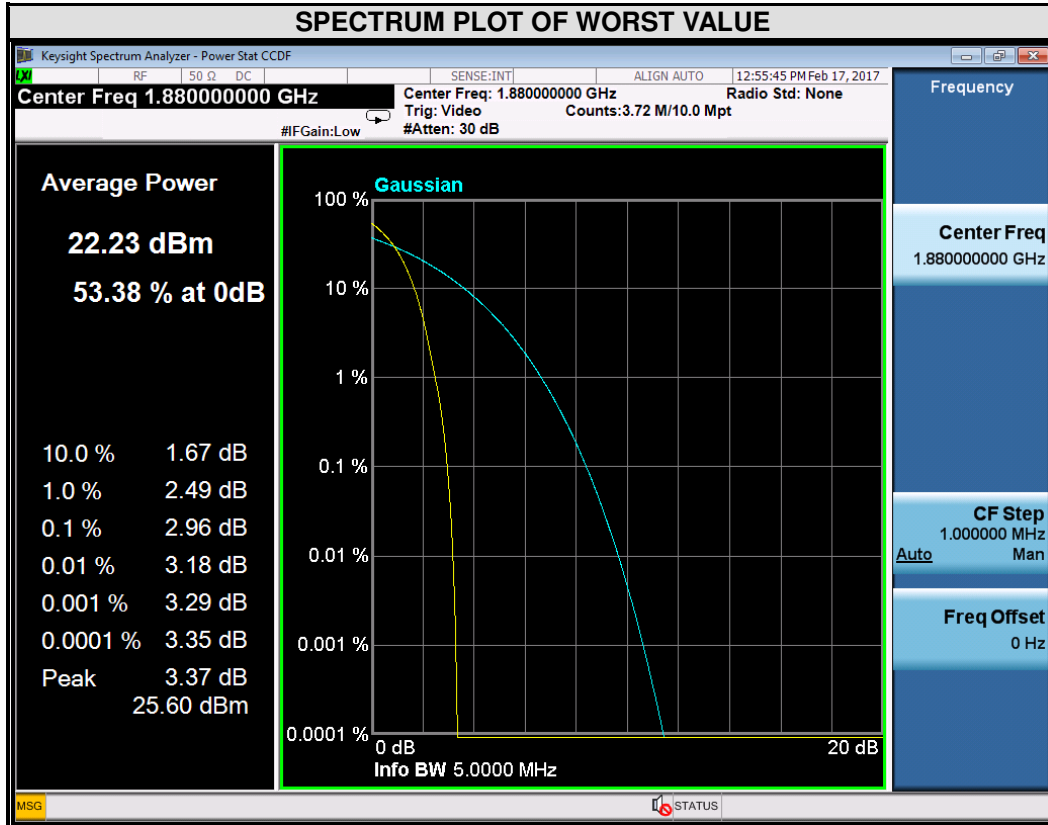



Test Report No.: RF170118W005-4

5 INFORMATION ON THE TESTING LABORATORIES

We, Bureau Veritas Shenzhen Co., Ltd. Dongguan Branch, were founded in 2002 to provide our best service in EMC, Radio, Telecom and Safety consultation. Our laboratories are accredited and approved according to ISO/IEC 17025.

If you have any comments, please feel free to contact us at the following:

Dongguan EMC/RF Lab:

Tel: +86-769-85935656

Fax: +86-769-85931080

Email: customerservice.dg@cn.bureauveritas.com

Web Site: www.adt.com.tw

The address and road map of all our labs can be found in our web site also.



BUREAU Test Report No.: RF170118W005-4
VERITAS

6 APPENDIX A – MODIFICATIONS RECORDERS FOR ENGINEERING CHANGES TO THE EUT BY THE LAB

No any modifications are made to the EUT by the lab during the test.

---END---