

# TEST REPORT

**REPORT NUMBER: B15X50034-FCC-Wifi\_Rev1**

**ON**

**Type of Equipment: Ilium X100 Smart Phone**  
**Model Number: Ilium X100**  
**Manufacturer: Shenzhen fortuneship technology, LTD**

**ACCORDING TO**

**FCC Part 15, Subpart C, 2014:**

15.205 Restricted bands of operation,  
15.209 Radiated emission limits; general requirements,  
15.247 Operation within the bands 902–928 MHz, 2400–2483.5 MHz, and  
5725–5850 MHz

**ANSI C63.10 2013:**American National Standard of Procedures for  
Compliance Testing of Unlicensed Wireless Devices

**China Telecommunication Technology Labs.**

*Month date, year*

*APR, 15, 2015*

*Signature*



He Guili

**Director**

**FCC ID:** ZC4X100  
**Report Date:** 2015-04-15

**Test Firm Name:** China Telecommunication Technology Labs  
**Registration Number:** 840587

#### Statement

The measurements shown in this report were made in accordance with the procedures described on test pages. All reported tests were carried out on a sample equipment to demonstrate limited compliance with FCC Parts 15, subpart C. The sample tested was found to comply with the requirements defined in the applied rules.

## CONTENTS

<b>1 GENERAL INFORMATION .....</b>	<b>4</b>
1.1 NOTES .....	4
1.2 TESTERS .....	5
1.3 TESTING LABORATORY INFORMATION .....	6
1.4 DETAILS OF APPLICANT OR MANUFACTURER .....	7
<b>2 TEST ITEM .....</b>	<b>8</b>
2.1 GENERAL INFORMATION .....	8
2.2 OUTLINE OF EUT .....	8
2.3 MODIFICATIONS INCORPORATED IN EUT .....	8
2.4 EQUIPMENT CONFIGURATION .....	8
2.5 OTHER INFORMATION .....	8
<b>3 SUMMARY OF TEST RESULTS .....</b>	<b>9</b>
<b>4 TEST RESULTS .....</b>	<b>10</b>
4.1 PEAK OUTPUT POWER-CONDUCTED .....	10
4.2 MAXIMUM AVERAGE OUTPUT POWER-CONDUCTED .....	42
4.3 PEAK POWER SPECTRAL DENSITY .....	44
4.4 6dB BANDWIDTH .....	50
4.5 FREQUENCY BAND EDGES .....	56
4.6 CONDUCTED EMISSION .....	61
4.7 RADIATED EMISSION MEASUREMENT .....	72
4.8 POWER LINE CONDUCTED EMISSIONS .....	82
<b>ANNEX A EXTERNAL PHOTOS .....</b>	<b>85</b>
<b>ANNEX B INTERNAL PHOTOS .....</b>	<b>85</b>
<b>ANNEX C DEVIATIONS FROM PRESCRIBED TEST METHODS .....</b>	<b>85</b>

## 1 General Information

### 1.1 Notes

All reported tests were carried out on a sample equipment to demonstrate limited compliance with FCC Parts 15, subpart C and ANSI C63.10-2013 and FCC DA 00-705.

The test results of this test report relate exclusively to the item(s) tested as specified in section 2.

The following deviation from, additions to, or exclusions from the test specifications have been made. See Annex C.

China Telecommunication Technology Labs.(CTTL) authorizes the applicant or manufacturer (see section 1.4) to reproduce this report provided, and the test report may only be reproduced or published in full. Reproduction or publication of extracts from the report requires the prior written approval of director of CTTL Mr. He Guili.

Any use which a third party makes of this report, or any reliance on or decisions to be made based on it, are the responsibility of such third parties. CTTL accepts no responsibility for damages, if any, suffered by any third party as a result of decisions made or actions based on this report.

## 1.2 Testers

Name: Li Guoqing  
Position: Engineer  
Department: Department of EMC test  
Date: 2015-04-15  
Signature: 李国庆

Editor of this test report:

Name: Li Guoqing  
Position: Engineer  
Department: Department of EMC test  
Date: 2015-04-15  
Signature: 李国庆

Technical responsibility for area of testing:

Name: Zou Dongyi  
Position: Manager  
Department: Department of EMC test  
Date: 2015-04-15  
Signature: 邹东屹

### 1.3 Testing Laboratory information

#### 1.3.1 Location

Name: China Telecommunication Technology Labs.  
Address: No. 11, Yue Tan Nan Jie, Xi Cheng District  
BEIJING  
P. R. CHINA, 100083  
Tel: +86 10 68094053  
Fax: +86 10 68011404  
Email: [emc@chinattl.com](mailto:emc@chinattl.com)

#### 1.3.2 Details of accreditation status

Accredited by: China National Accreditation Service for Conformity  
Assessment (CNAS)  
Registration number: CNAL Registration No.L0570  
Standard: ISO/IEC 17025:2005

#### 1.3.3 Test location, where different from section 1.3.1

Name: -----  
Street: -----  
City: -----  
Country: -----  
Telephone: -----  
Fax: -----  
Postcode: -----

## 1.4 Details of applicant or manufacturer

### 1.4.1 Applicant

Name: Coroporativo Lanix S.A. de C.V  
Address: Carrterera internacional Hermosillo-Nogales Km 8.5  
Country: Mexico  
Telephone: 6621090811  
Fax: --  
Contact: Oscar Guzman  
Telephone: +86 6621090811  
Email: Oguzman@lanix.ciim

### 1.4.2 Manufacturer (if different from applicant in section 1.4.1)

Name: Shenzhen fortuneship technology.,LTD  
Address: 6th Floor, Kingson Building, New Energ Innovation Industrial Park,  
No.1Chuangsheng Road, Nanshan District, Shenzhen, P.R.China

### 1.4.3 Manufactory (if different from applicant in section 1.4.1)

Name: Shenzhen fortuneship technology.,LTD  
Address: 6th Floor, Kingson Building, New Energ Innovation Industrial Park,  
No.1Chuangsheng Road, Nanshan District, Shenzhen, P.R.China

## 2 Test Item

### 2.1 General Information

Manufacturer: Shenzhen fortuneship technology.,LTD  
 Name: Ilium X100 Smart Phone  
 Model Number: Ilium X100  
 Serial Number: --  
 Production Status: Production  
 Receipt date of test item: 2015-01-14

### 2.2 Outline of EUT

E.U.T. is a GSM850/ PCS1900 Dual-band and UMTS/HSDPA/HSUPA FDD II/V bands Terminal Equipment with Bluetooth and wifi.

### 2.3 Modifications Incorporated in EUT

The EUT has not been modified from what is described by the brand name and unique type identification stated above.

### 2.4 Equipment Configuration

Equipment configuration list:

Item	Generic Description	Manufacturer	Type	Serial No.	Remarks
A	Mobile phone	Shenzhen fortuneship technology.,LTD	X100	--	None
B	Battery	None	None	--	None
C	Adaptor	None	None	--	None

### 2.5 Other Information

--



### 3 Summary of Test Results

A brief summary of the tests carried out is shown as following.

	Name of Test	Result
1、	Maximum Peak Output Power	Pass
2、	Maximum Average Output Power	Pass
3、	Peak Power Spectral Density	Pass
4、	6dB Occupied Bandwidth	Pass
5、	Band Edges Compliance	Pass
6、	Transmitter Spurious Emission-Conducted	Pass
7、	Transmitter Spurious Emission-Radiated	Pass
8、	Power line Conducted Emissions	Pass
Note: none		

## 4 Test Results

### 4.1 Peak Output Power-Conducted

<b>Date of Tests</b>	2015-01-23~2015-04-15					
<b>Test conditions:</b>	Ambient Temperature:15°C-35°C Relative Humidity:30%-60% Air pressure: 86-106kPa					
<b>Test Results:</b>	Pass					
<b>Test equipment Used:</b>						
<b>Number</b>	<b>Description</b>	<b>Manufacturer</b>	<b>Model Number</b>	<b>Serial Number</b>	<b>Cal Due</b>	<b>State</b>
1	EMI Test Receiver	R/S	ESU40	100350	2015-03-07	Normal

#### 4.1.1 Measurement Limit

Standard	Limit (dBm)
FCC Part 15.247(b)	< 30

#### 4.1.2 Test procedure

The measurement is according to ANSI C63.10 clause 11.2

1. The output power of EUT was connected to the spectrum analyzer. The path loss was compensated to the results for each measurement.
2. Enable EUT transmitter maximum power continuously.
3. Set RBW  $\geq$  OBW, Set the appropriate VBW
4. Detector : Peak.
5. Trace mode: Max Hold

#### 4.1.3 Measurement Results:

802.11b/g mode

Mode	Data Rate(Mbps)	Test Result(dBm)			Conclusion
		Ch1	Ch6	Ch11	
802.11b	1	18.43	19.08	18.91	Pass
	2	18.42	19.03	18.81	Pass
	5.5	18.01	18.59	18.39	Pass
	11	18.26	18.98	18.70	Pass
802.11g	6	20.52	21.23	21.31	Pass
	9	20.74	21.56	21.58	Pass
	12	20.58	20.96	21.31	Pass
	18	20.47	20.98	20.88	Pass
	24	20.60	21.31	21.14	Pass

	36	20.69	21.38	21.16	Pass
	48	20.67	21.06	21.33	Pass
	54	20.69	21.35	21.02	Pass

802.11n mode

Mode	Data Rate(Mbps)	Teat Result(dBm)			Conclusion
		Ch1	Ch6	Ch11	
802.11n (20MHz)	MCS0	20.69	21.12	20.88	Pass
	MCS1	20.56	21.16	21.05	Pass
	MCS2	20.50	21.07	21.23	Pass
	MCS3	20.65	21.28	20.96	Pass
	MCS4	20.26	20.83	20.83	Pass
	MCS5	20.61	21.33	21.28	Pass
	MCS6	20.78	21.59	21.39	Pass
	MCS7	20.68	20.98	20.82	Pass
802.11n (40MHz)	MCS0	/	/	/	/
	MCS1	/	/	/	/
	MCS2	/	/	/	/
	MCS3	/	/	/	/
	MCS4	/	/	/	/
	MCS5	/	/	/	/
	MCS6	/	/	/	/
	MCS7	/	/	/	/

Conclusion: PASS

Test figure as below:

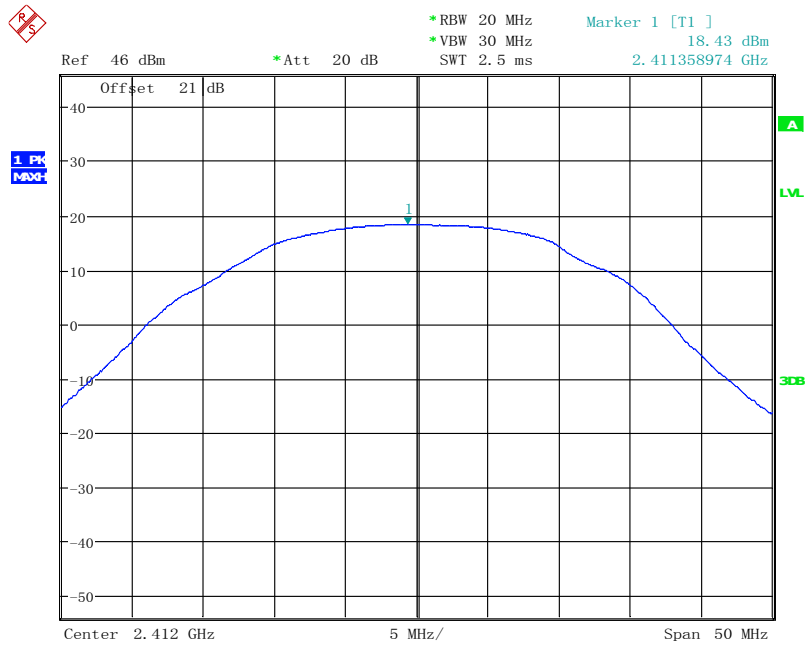

Date: 15. APR. 2015 14:46:43

Fig.1 Peak Conducted Output Power CH1, 11b, Rate1

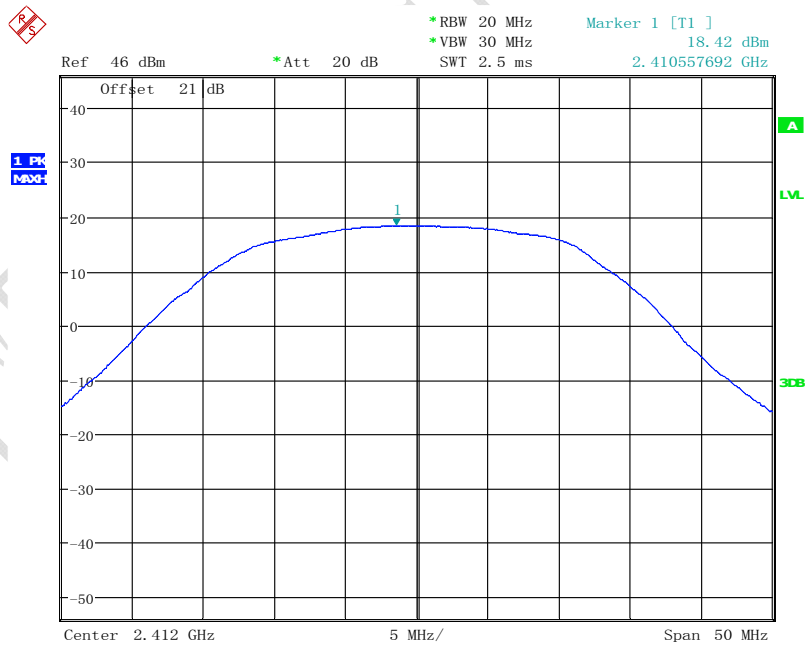

Date: 15. APR. 2015 14:46:56

Fig.2 Peak Conducted Output Power CH1, 11b, Rate2

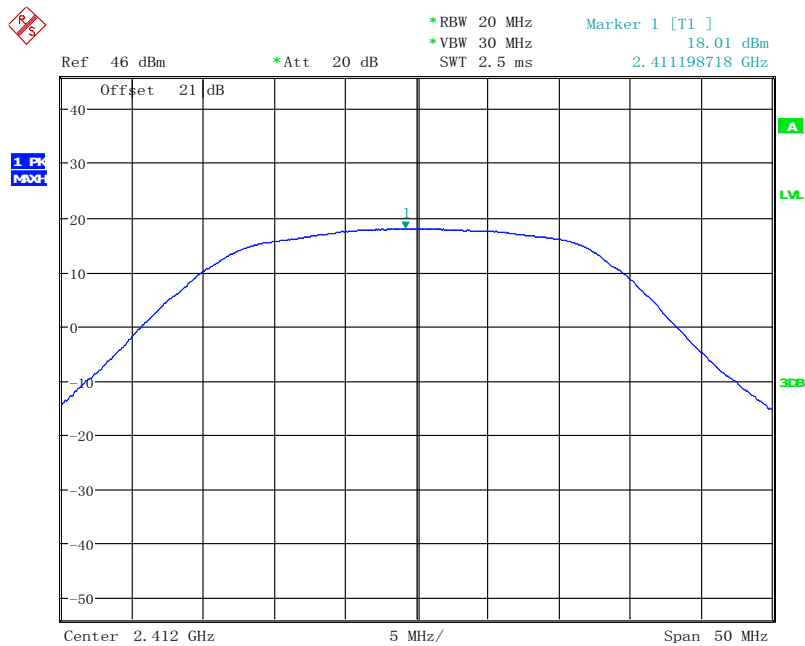

Date: 15. APR. 2015 14:47:08

Fig.3 Peak Conducted Output Power CH1, 11b, Rate5.5

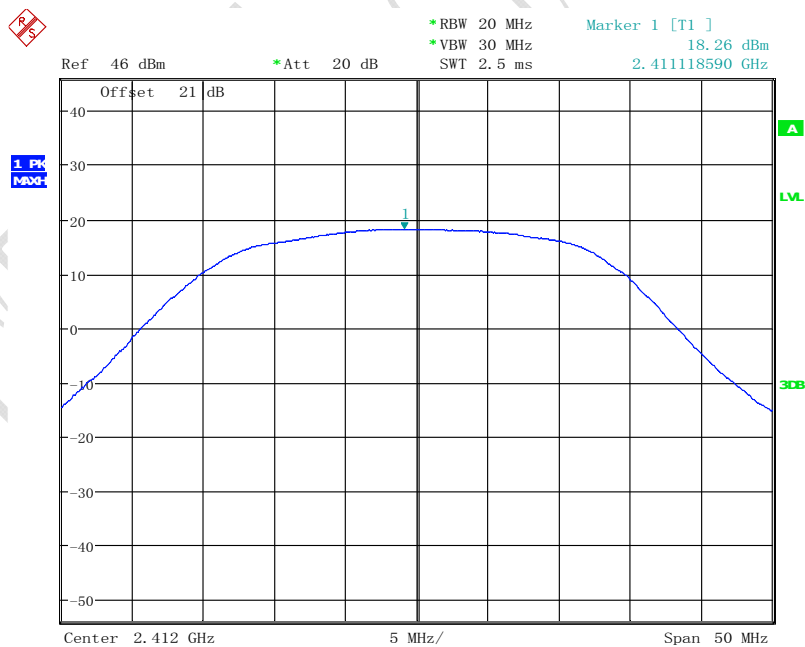

Date: 15. APR. 2015 14:47:24

Fig.4 Peak Conducted Output Power CH1, 11b, Rate11

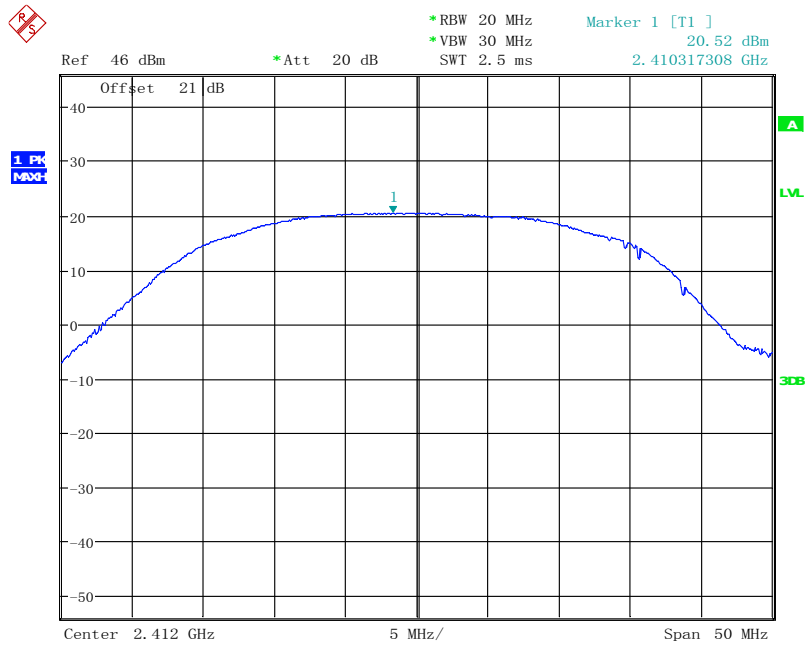

Date: 15. APR. 2015 14:47:39

Fig.5 Peak Conducted Output Power CH1, 11g, Rate6

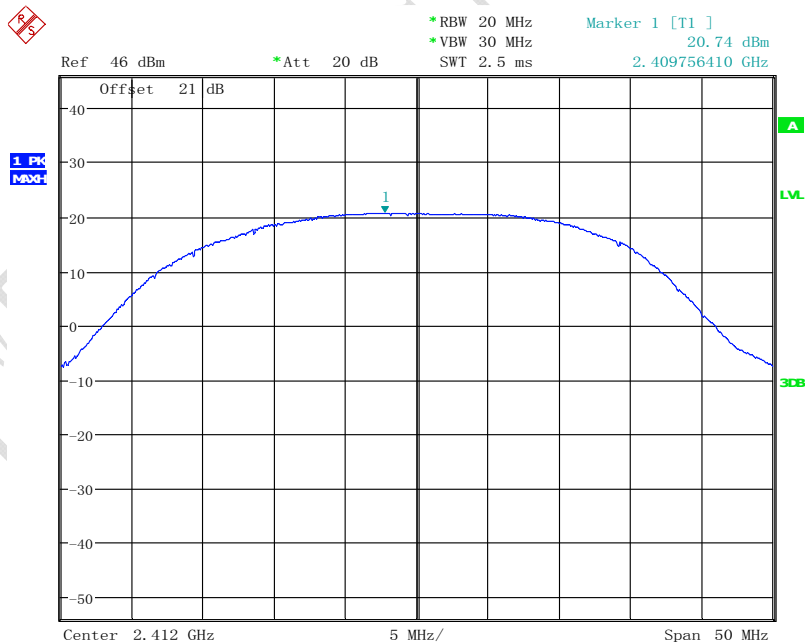

Date: 15. APR. 2015 14:47:51

Fig.6 Peak Conducted Output Power CH1, 11g, Rate9

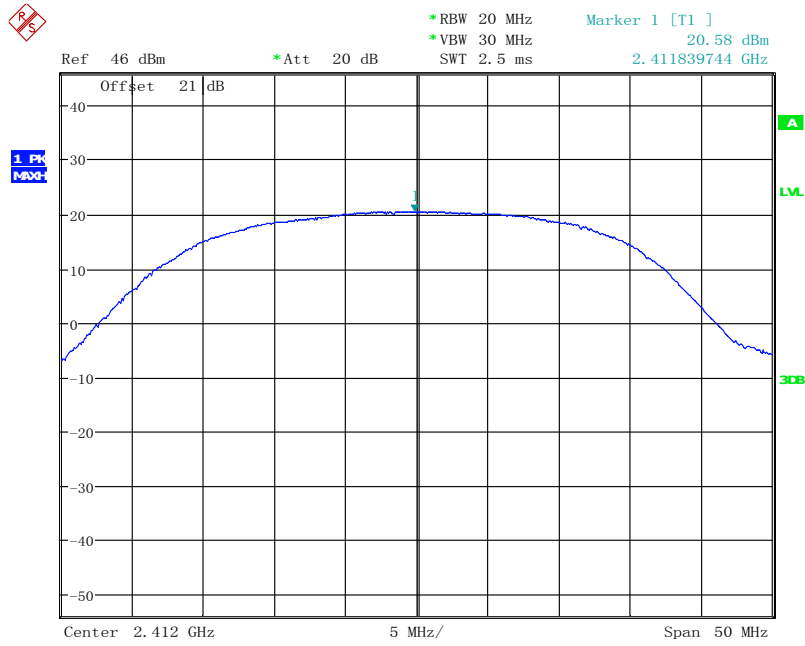

Date: 15. APR. 2015 14:48:05

Fig.7 Peak Conducted Output Power CH1, 11g, Rate12

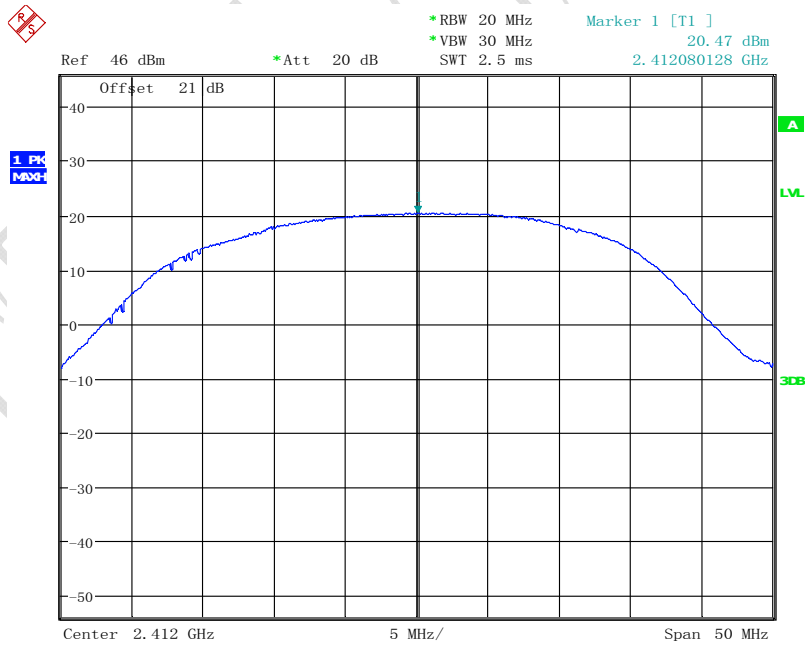

Date: 15. APR. 2015 14:48:17

Fig.8 Peak Conducted Output Power CH1, 11g, Rate18

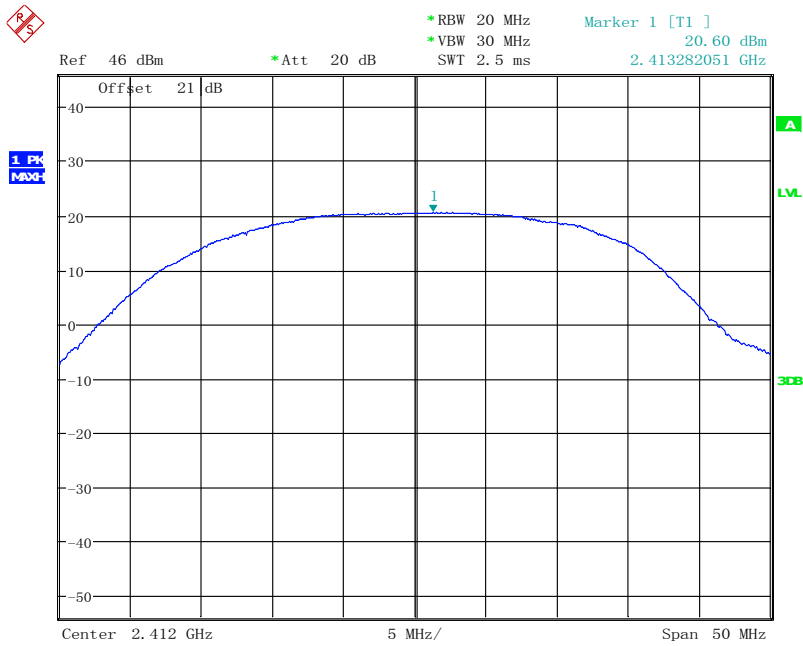

Date: 15. APR. 2015 14:48:31

Fig.9 Peak Conducted Output Power CH1, 11g, Rate24

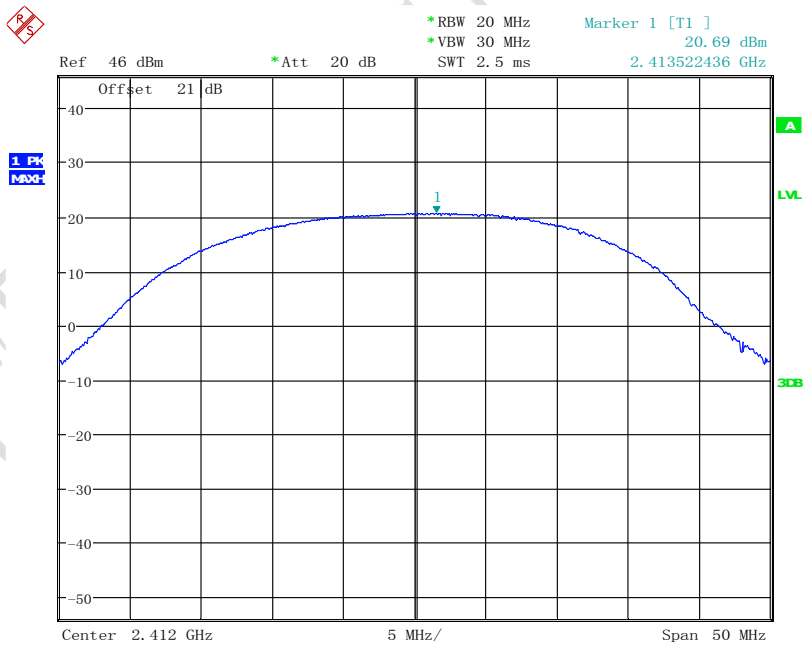

Date: 15. APR. 2015 14:48:44

Fig.10 Peak Conducted Output Power CH1, 11g, Rate36



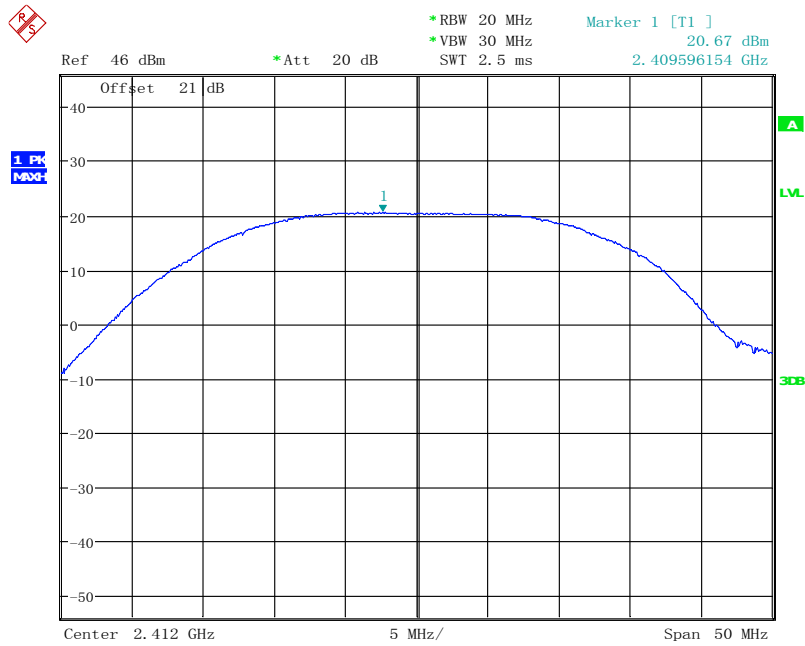

Date: 15. APR. 2015 14:48:57

Fig.11 Peak Conducted Output Power CH1, 11g, Rate48

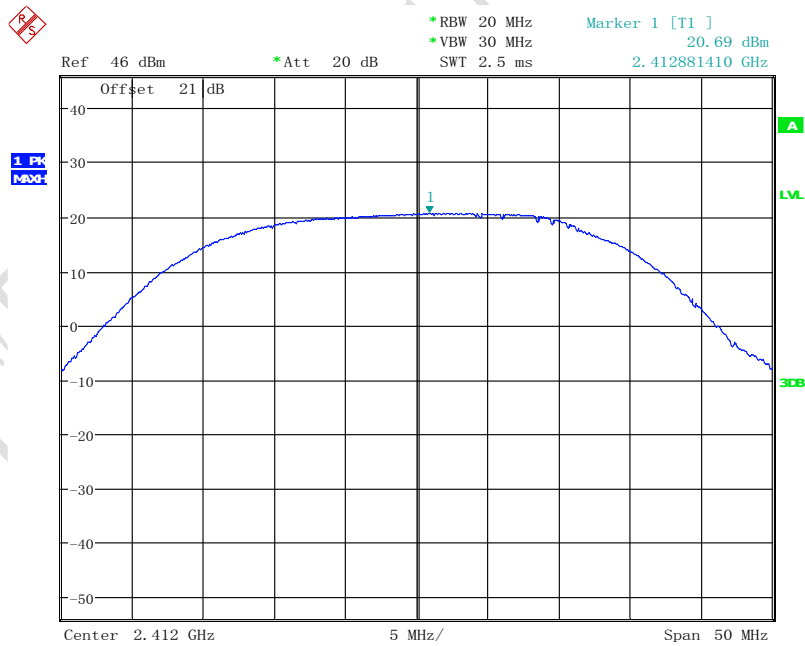

Date: 15. APR. 2015 14:49:09

Fig.12 Peak Conducted Output Power CH1, 11g, Rate54

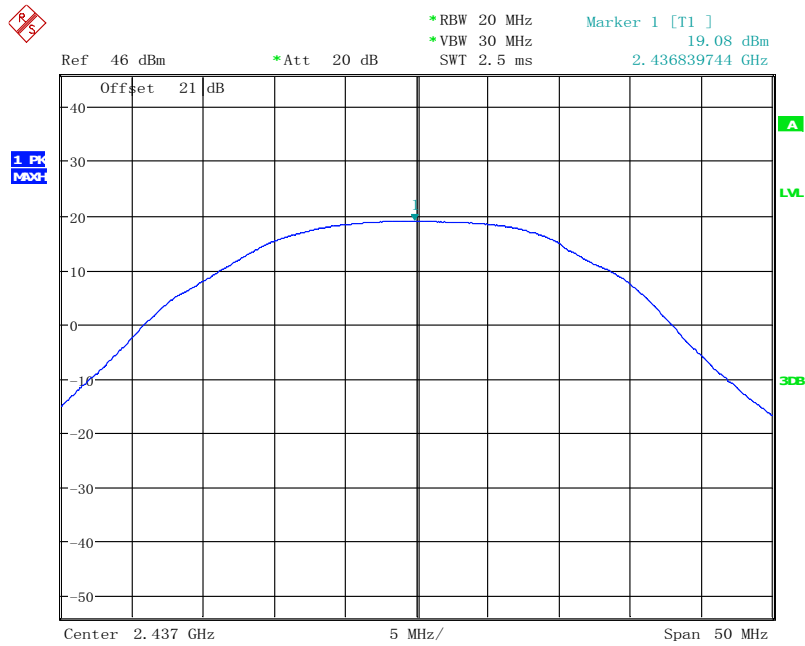

Date: 15. APR. 2015 14:51:19

Fig.13 Peak Conducted Output Power CH6, 11b, Rate1

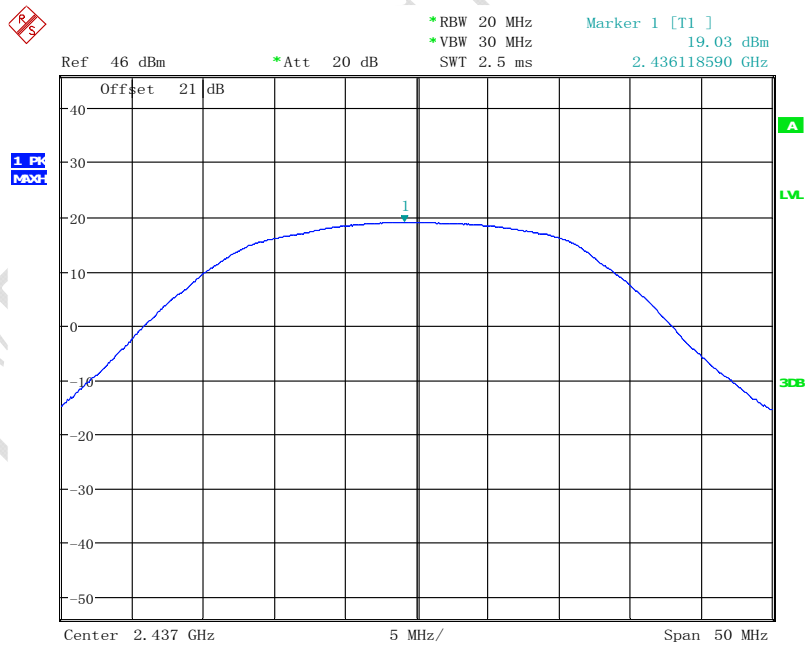

Date: 15. APR. 2015 14:51:31

Fig.14 Peak Conducted Output Power CH6, 11b, Rate2

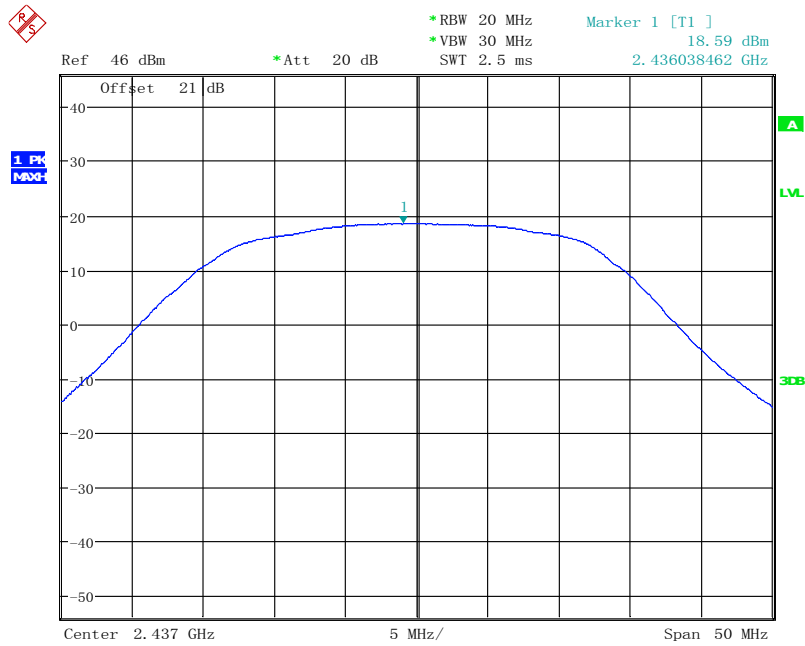

Date: 15. APR. 2015 14:51:44

Fig.15 Peak Conducted Output Power CH6, 11b, Rate5.5

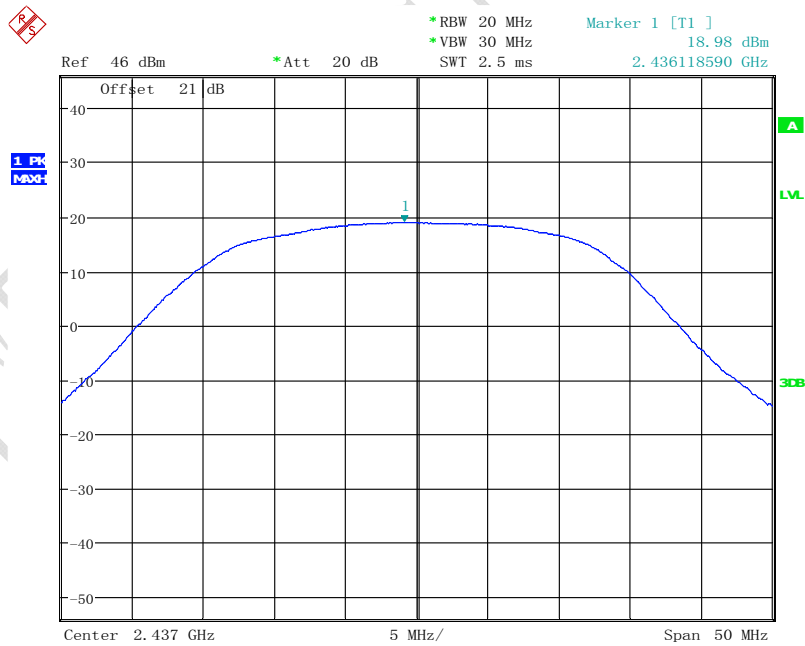

Date: 15. APR. 2015 14:51:57

Fig.16 Peak Conducted Output Power CH6, 11b, Rate11

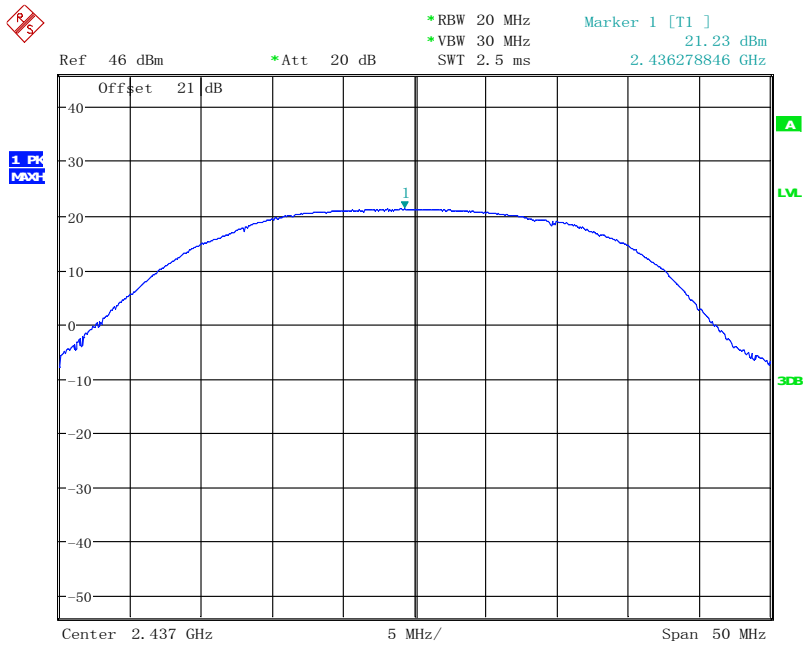

Date: 15. APR. 2015 14:52:14

Fig.17 Peak Conducted Output Power CH6, 11g, Rate6

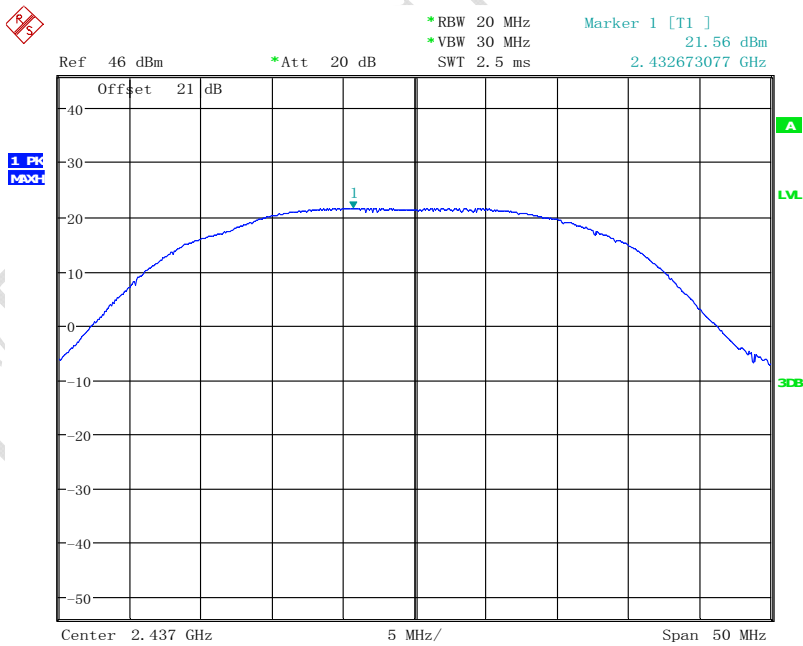

Date: 15. APR. 2015 14:52:28

Fig.18 Conducted Output Power CH6, 11g, Rate9

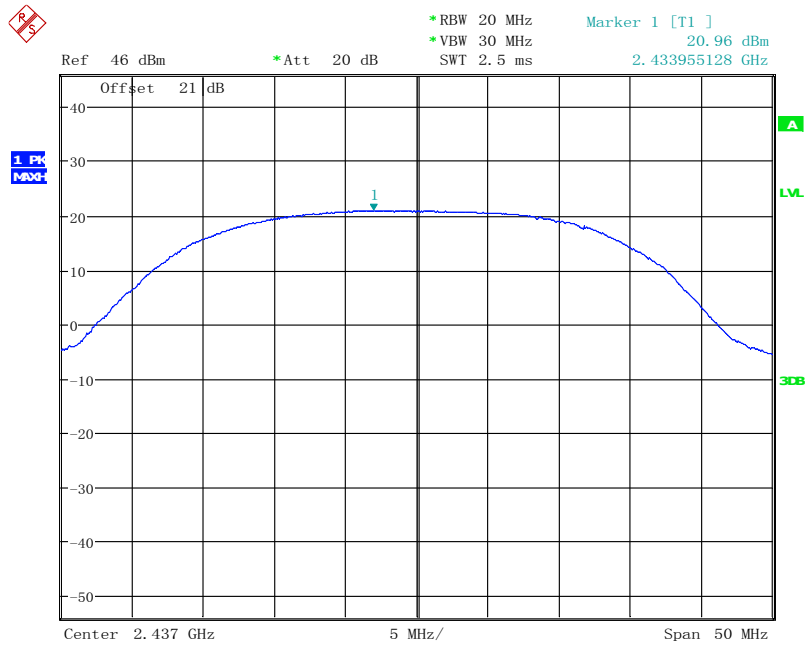

Date: 15. APR. 2015 14:52:41

Fig.19 Conducted Output Power CH6, 11g, Rate12

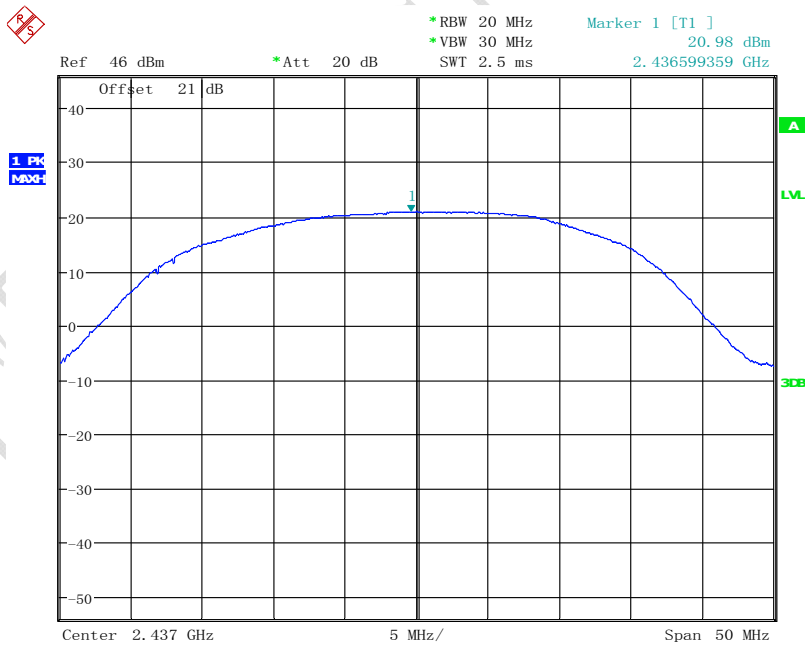

Date: 15. APR. 2015 14:52:56

Fig.20 Conducted Output Power CH6, 11g, Rate18

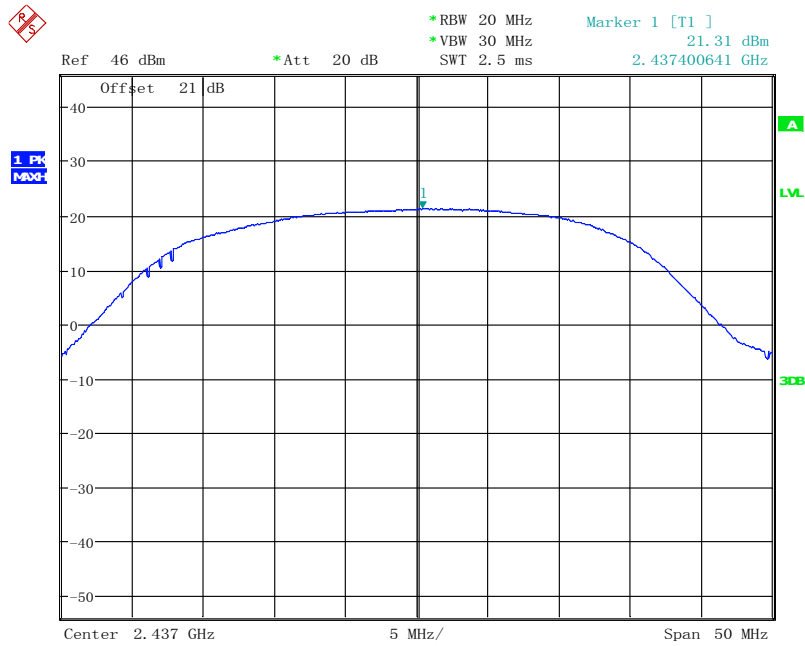

Date: 15. APR. 2015 14:53:09

Fig.21 Conducted Output Power CH6, 11g, Rate24

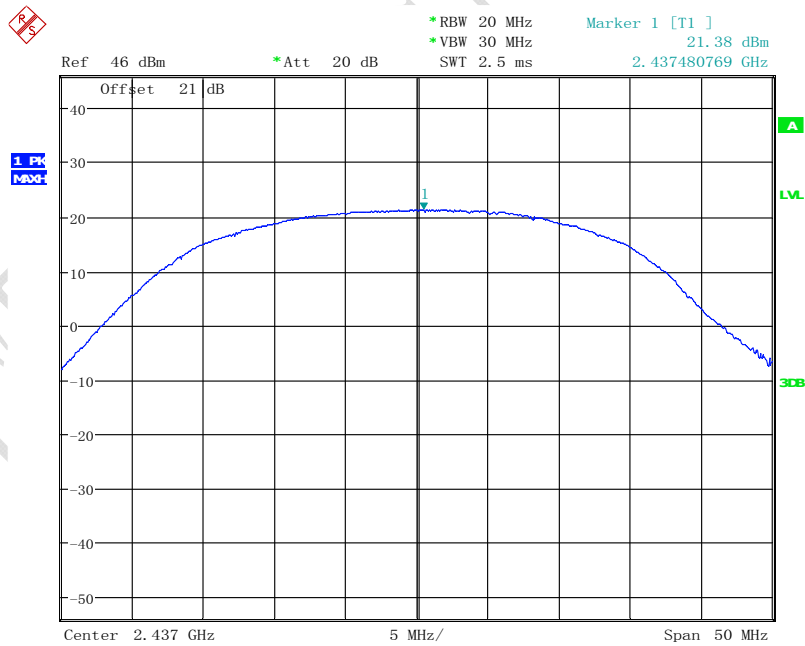

Date: 15. APR. 2015 14:53:21

Fig.22 Conducted Output Power CH6, 11g, Rate36

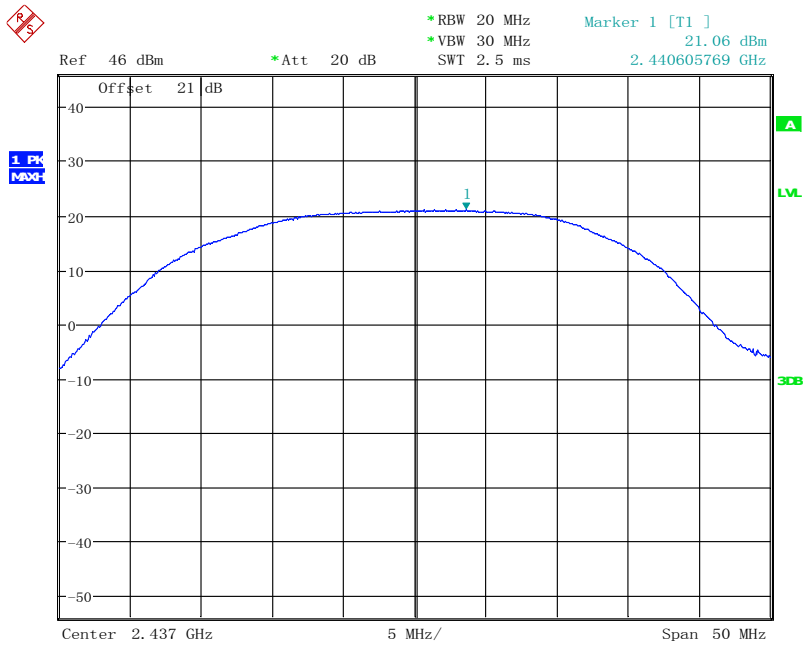

Date: 15. APR. 2015 14:53:33

Fig.23 Conducted Output Power CH6, 11g, Rate48

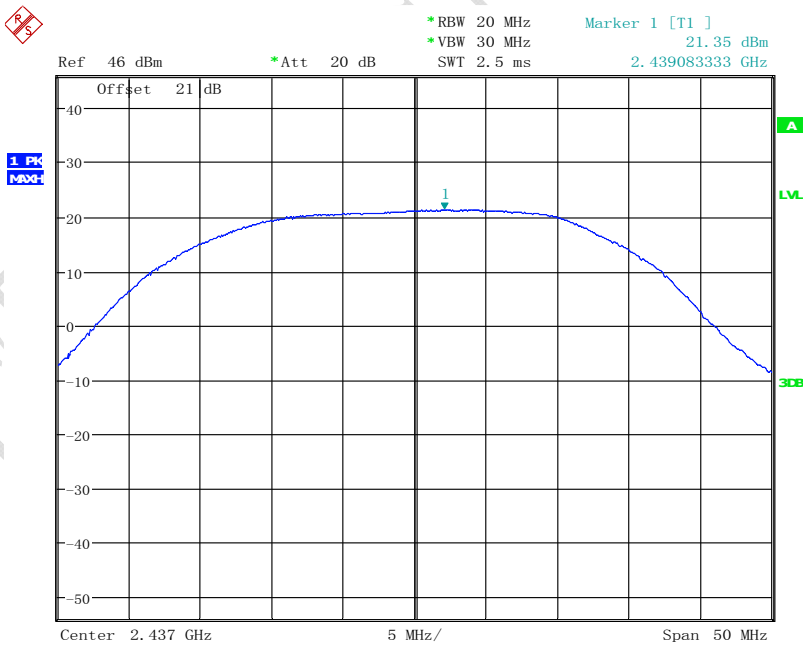

Date: 15. APR. 2015 14:53:45

Fig.24 Conducted Output Power CH6, 11g, Rate54

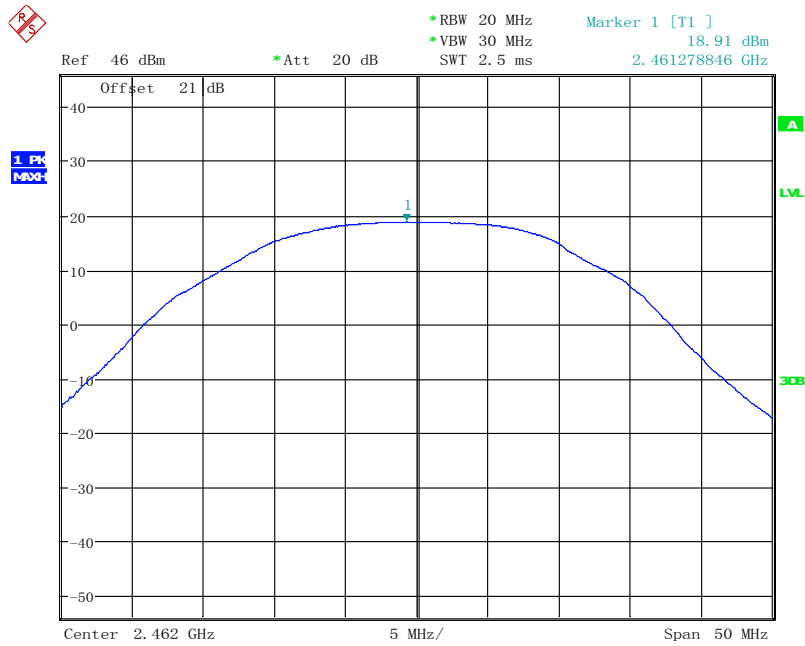

Date: 15. APR. 2015 14:56:05

Fig.25 Conducted Output Power CH11, 11b, Rate1

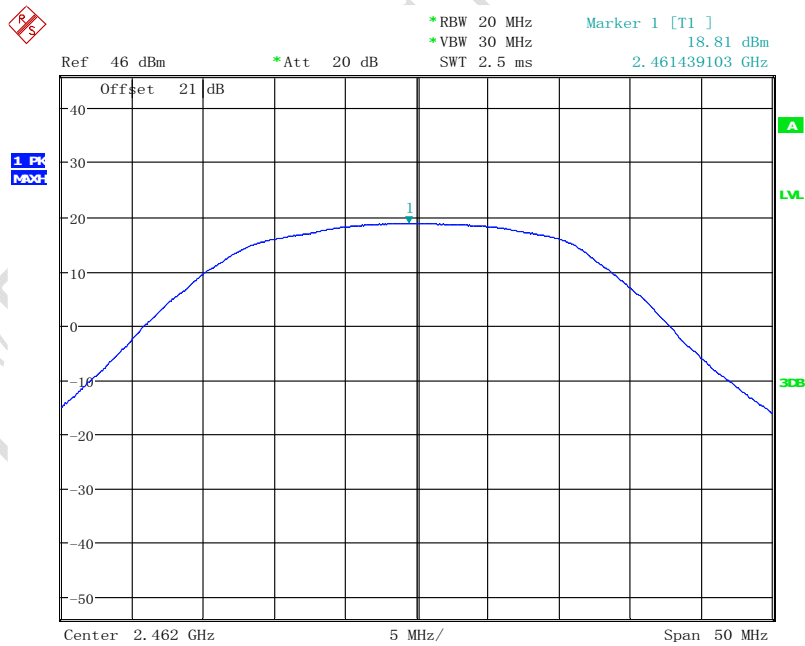

Date: 15. APR. 2015 14:56:19

Fig.26 Conducted Output Power CH11, 11b, Rate2



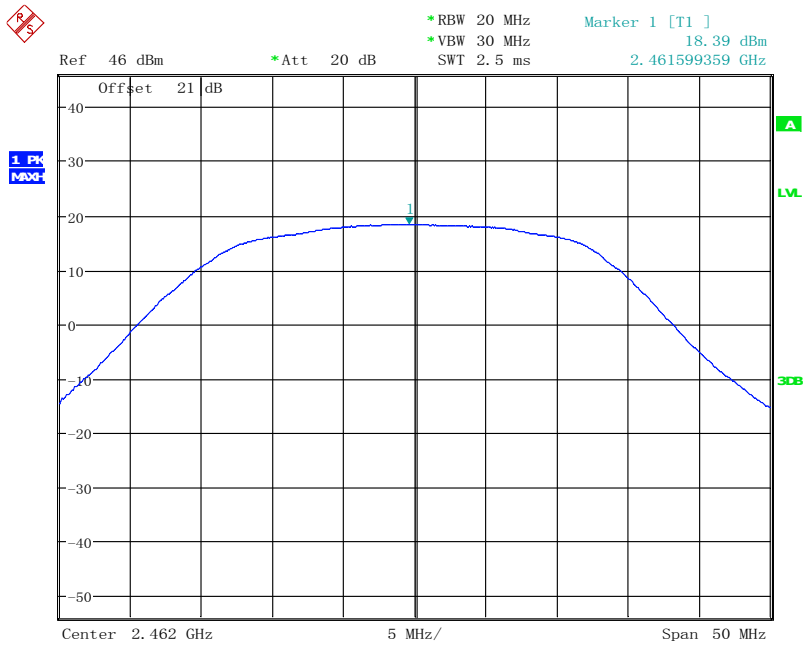

Date: 15. APR. 2015 14:56:31

Fig.27 Conducted Output Power CH11, 11b, Rate5.5

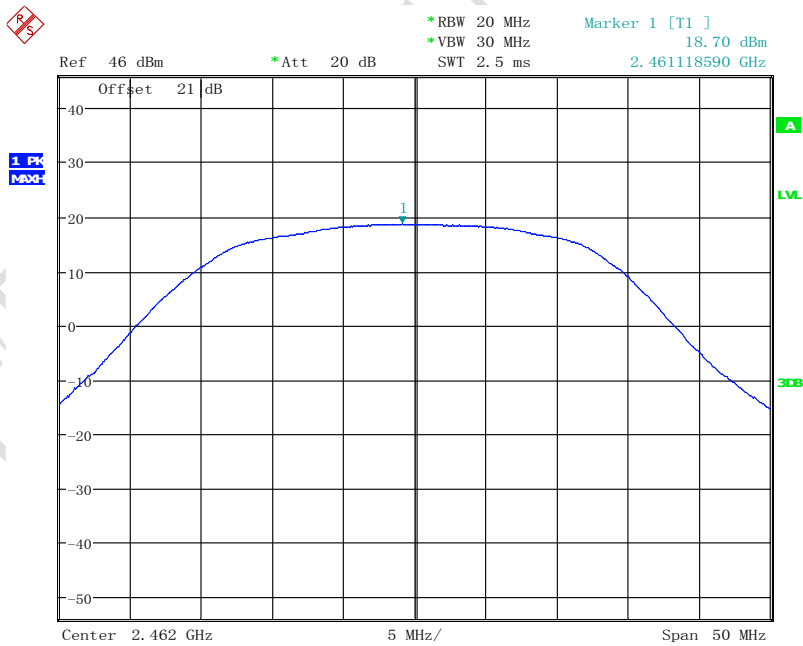

Date: 15. APR. 2015 14:56:44

Fig.28 Conducted Output Power CH11, 11b, Rate11

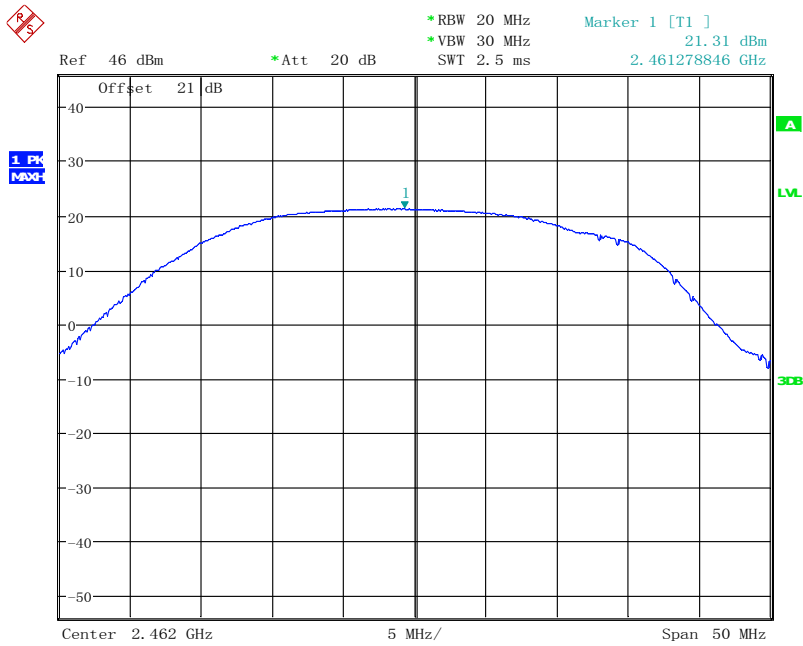

Date: 15. APR. 2015 14:56:58

Fig.29 Conducted Output Power CH11, 11g, Rate6

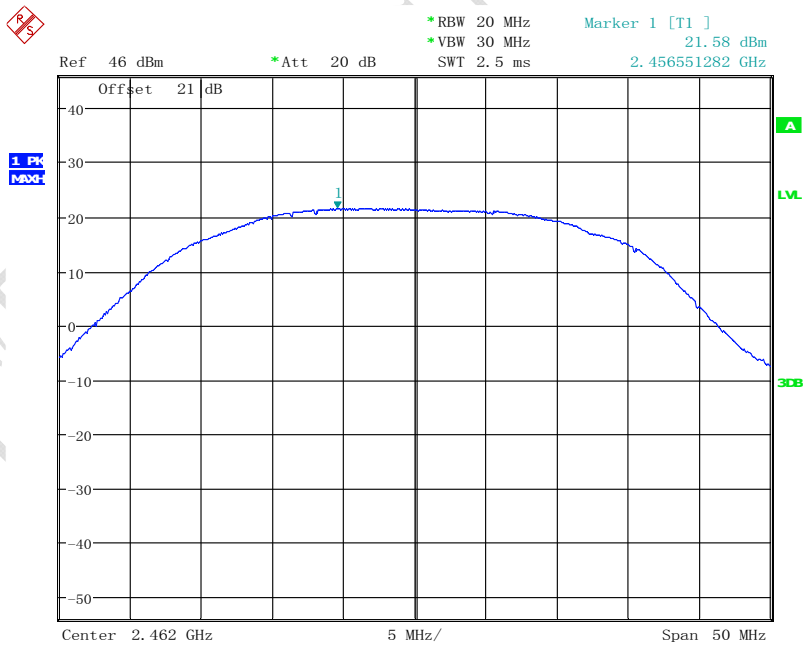

Date: 15. APR. 2015 14:57:11

Fig.30 Conducted Output Power CH11, 11g, Rate9

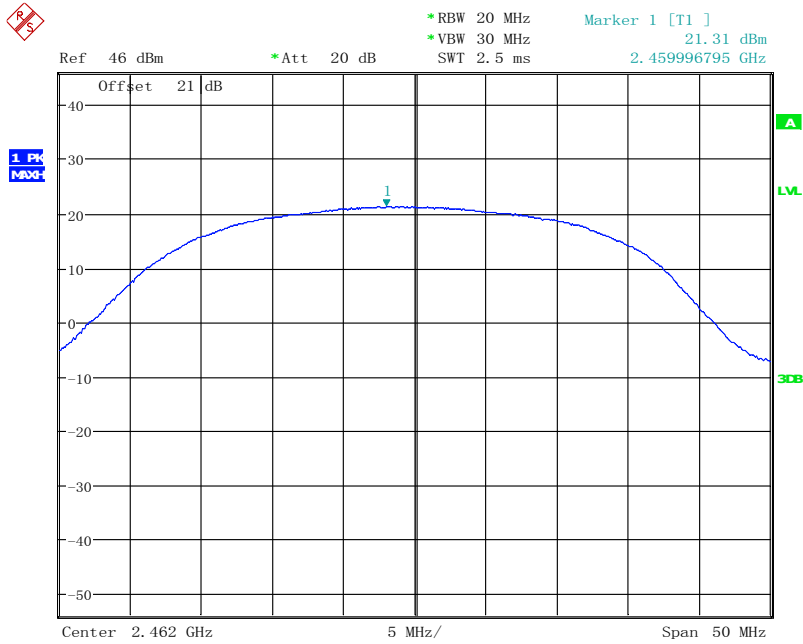

Date: 15. APR. 2015 14:57:27

Fig.31 Conducted Output Power CH11, 11g, Rate12

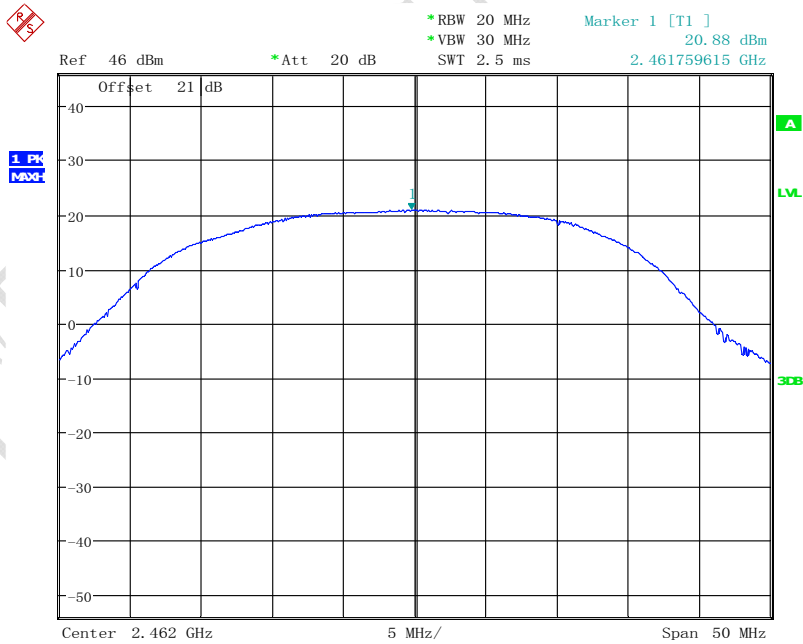

Date: 15. APR. 2015 14:57:39

Fig.32 Conducted Output Power CH11, 11g, Rate18

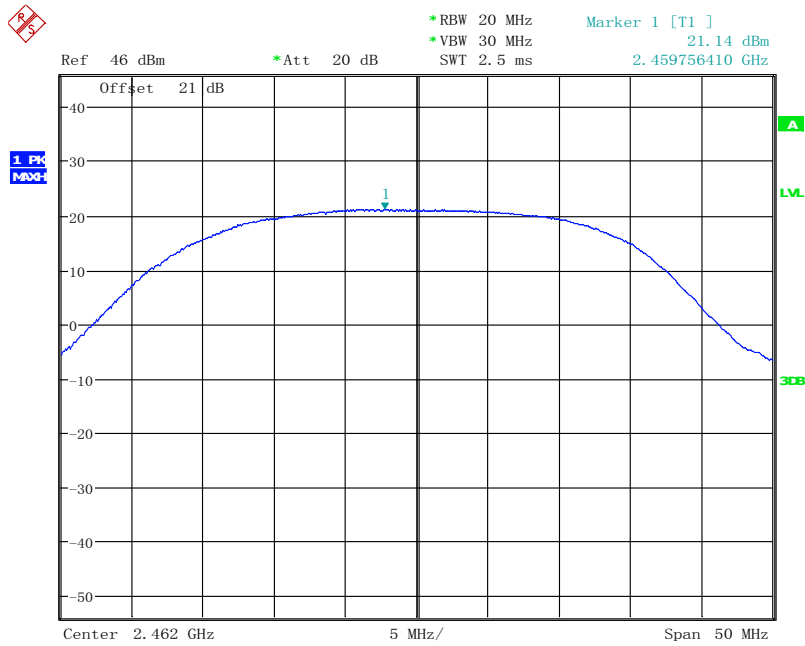

Date: 15. APR. 2015 14:57:53

Fig.33 Conducted Output Power CH11, 11g, Rate24

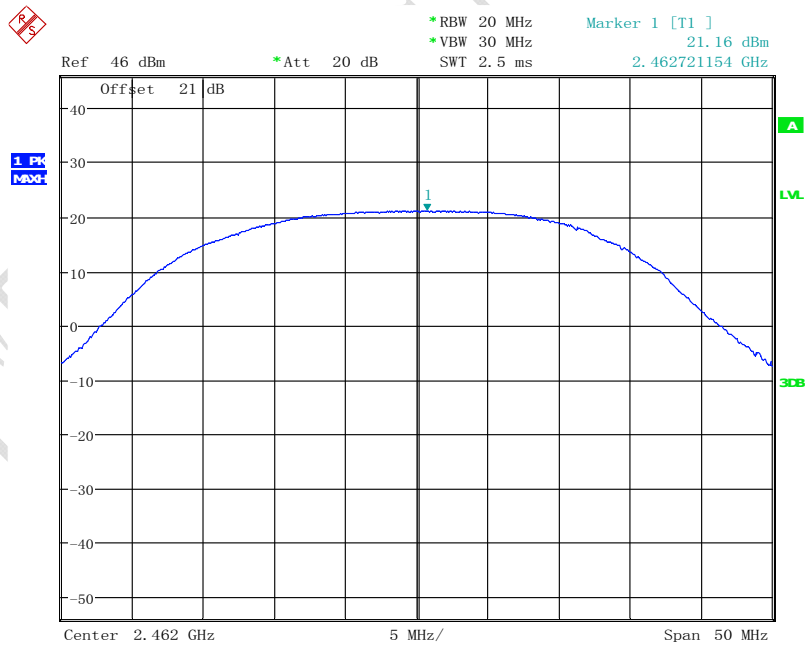

Date: 15. APR. 2015 14:58:05

Fig.34 Conducted Output Power CH11, 11g, Rate36

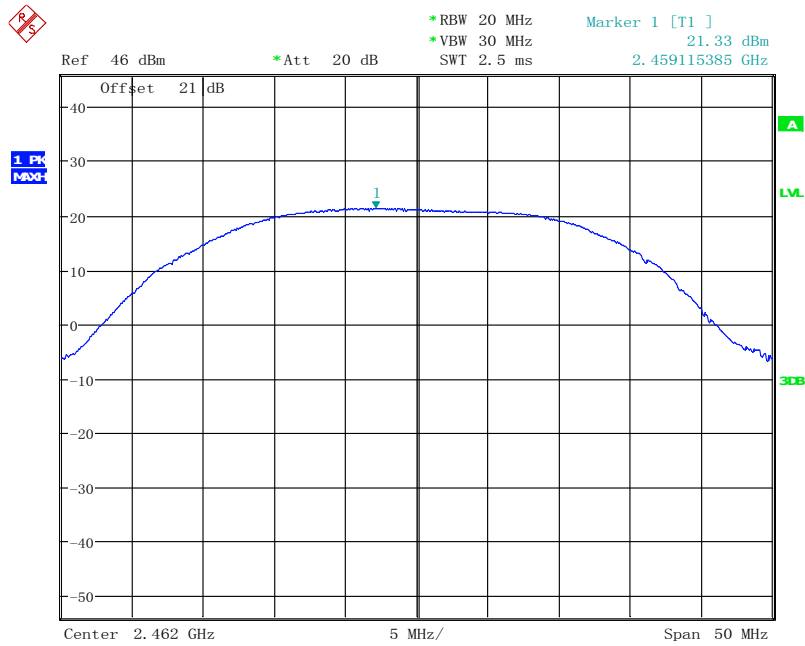

Date: 15. APR. 2015 14:58:16

Fig.35 Conducted Output Power CH11, 11g, Rate48

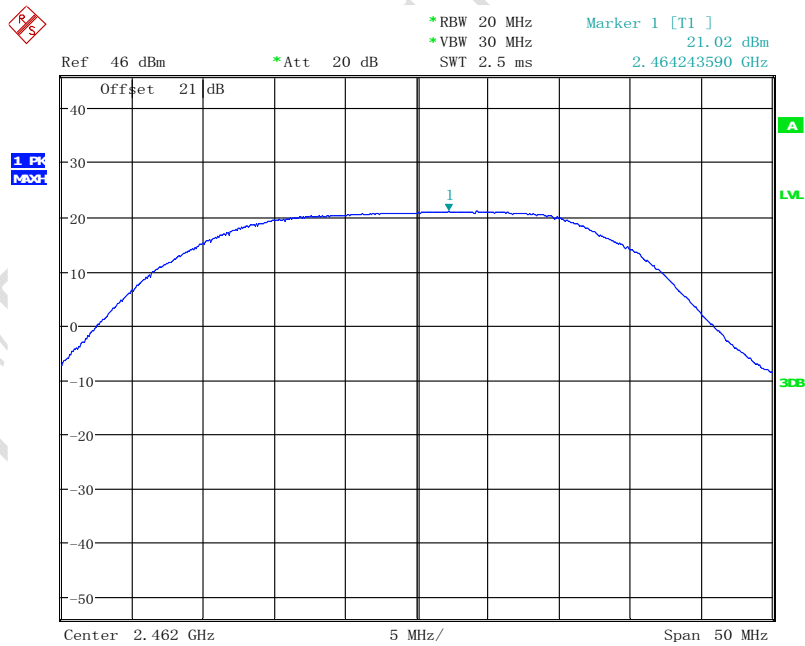

Date: 15. APR. 2015 14:58:28

Fig.36 Conducted Output Power CH11, 11g, Rate54

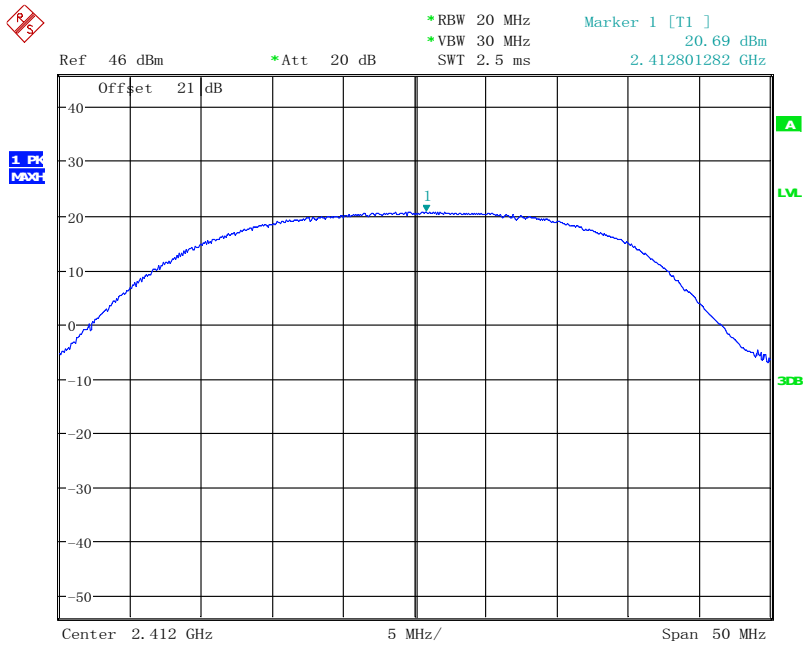

Date: 15. APR. 2015 14:49:24

Fig.37 Conducted Output Power CH1, 11n(20MHz), Rate MCS0

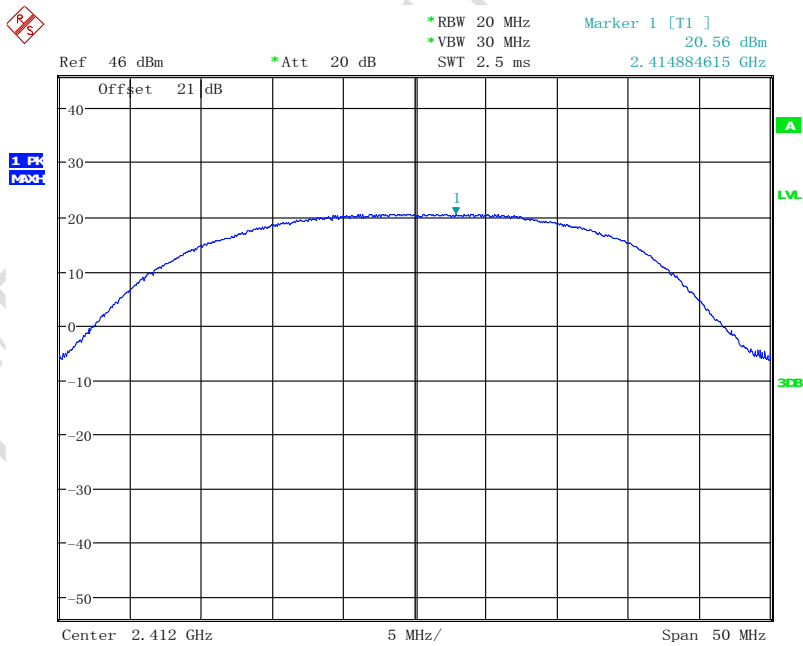

Date: 15. APR. 2015 14:49:37

Fig.38 Conducted Output Power CH1, 11n(20MHz), Rate MCS1

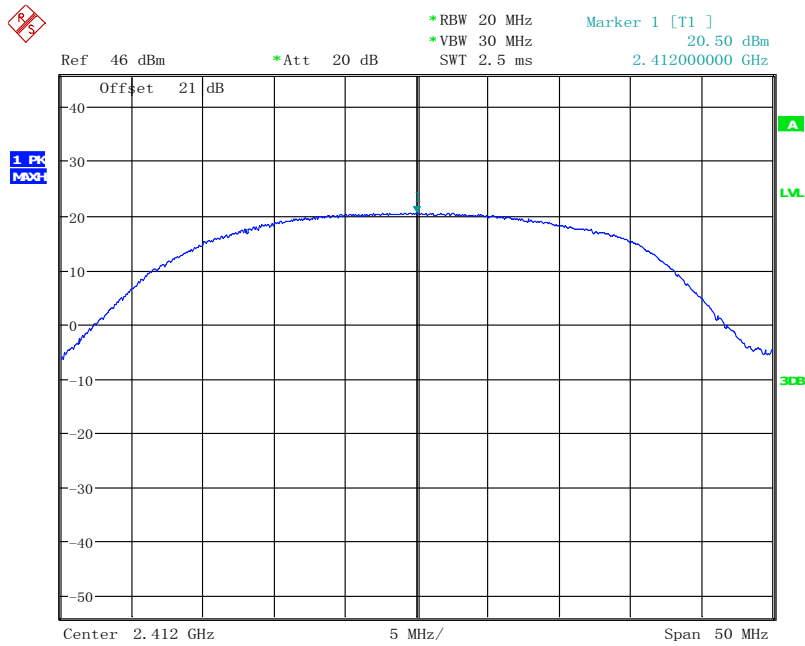

Date: 15. APR. 2015 14:49:49

Fig.39 Conducted Output Power CH1, 11n(20MHz), Rate MCS2

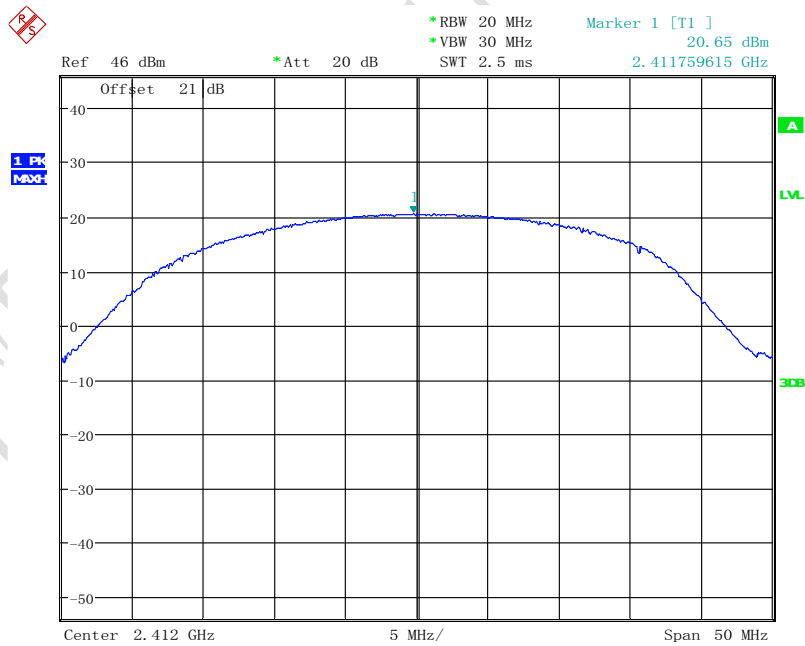

Date: 15. APR. 2015 14:50:01

Fig.40 Conducted Output Power CH1, 11n(20MHz), Rate MCS3

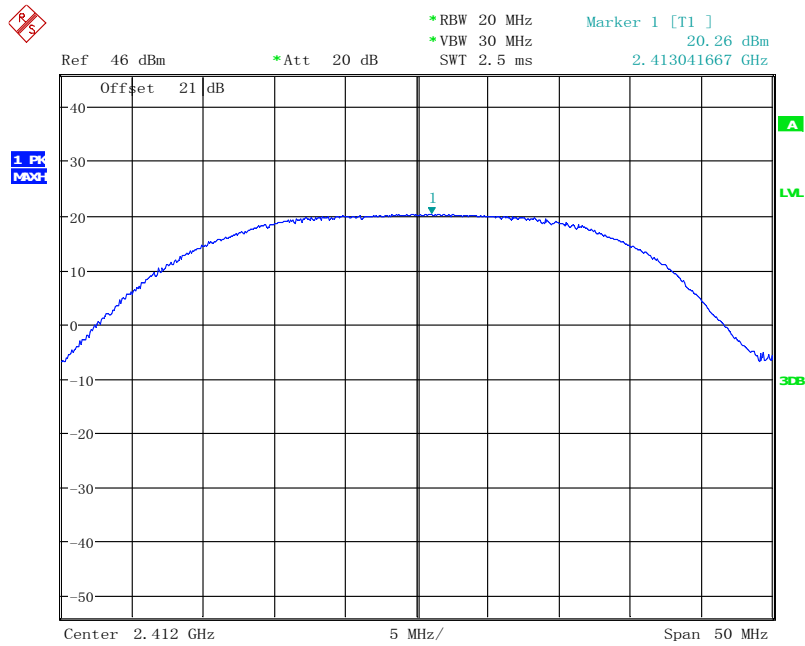

Date: 15. APR. 2015 14:50:13

Fig.41 Conducted Output Power CH1, 11n(20MHz), Rate MCS4

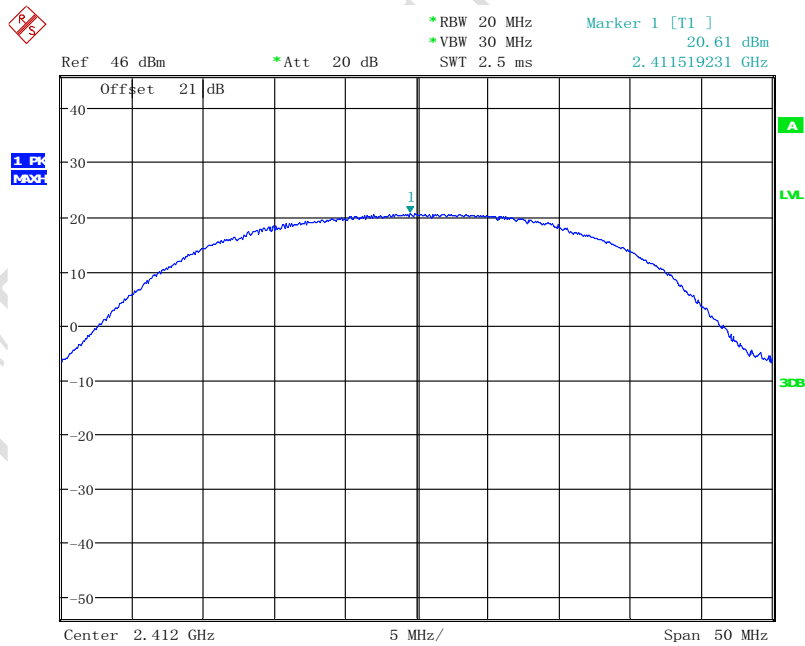

Date: 15. APR. 2015 14:50:29

Fig.42 Conducted Output Power CH1, 11n(20MHz), Rate MCS5



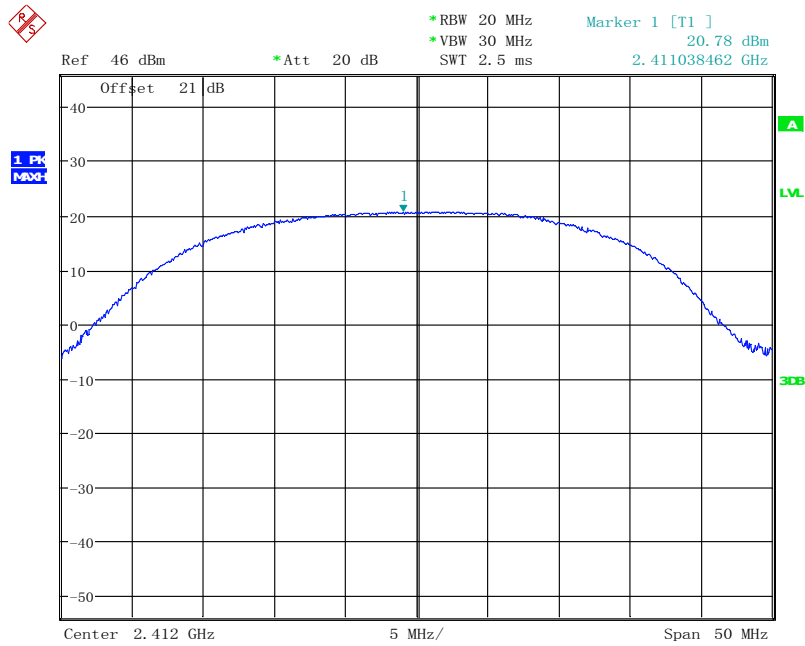

Date: 15. APR. 2015 14:50:41

Fig.43 Conducted Output Power CH1, 11n(20MHz), Rate MCS6

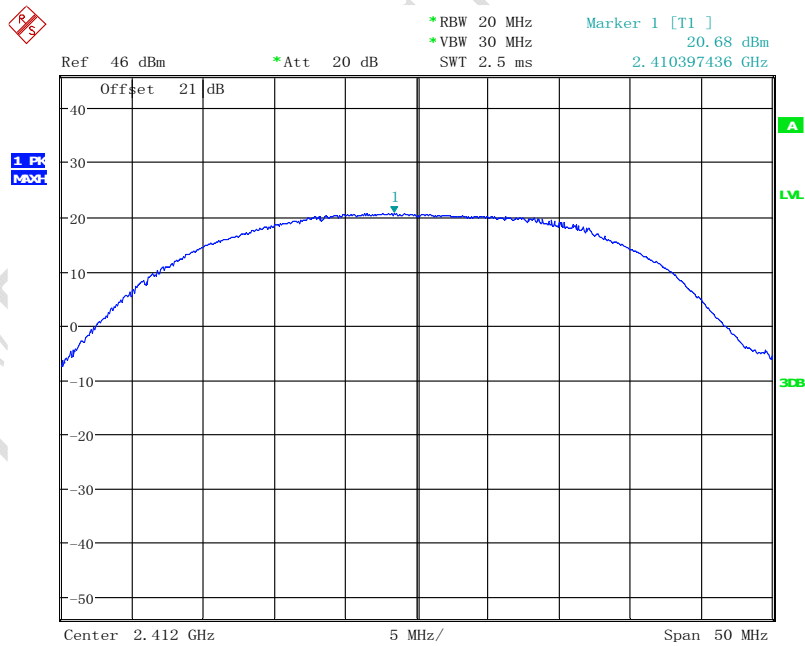

Date: 15. APR. 2015 14:50:54

Fig.44 Conducted Output Power CH1, 11n(20MHz), Rate MCS7

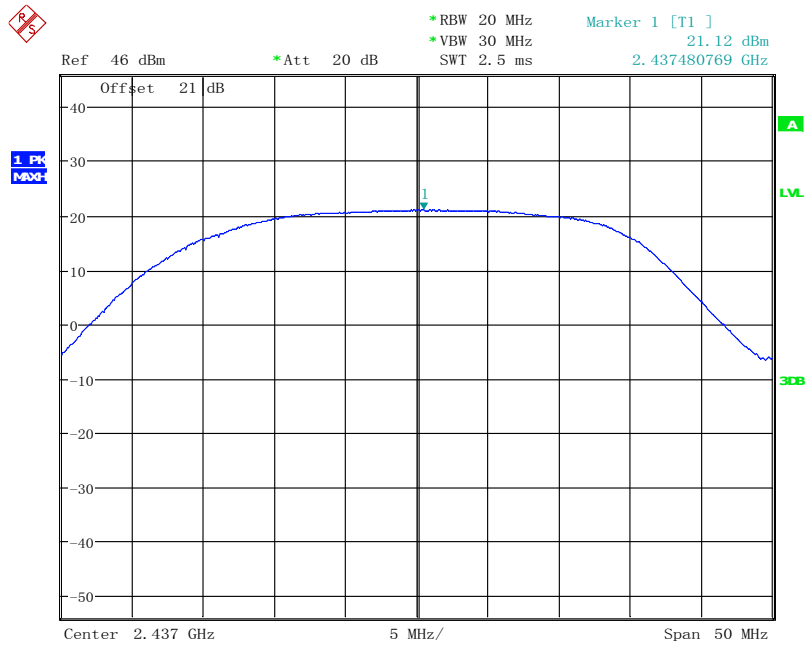

Date: 15. APR. 2015 14:54:19

Fig.45 Conducted Output Power CH6, 11n(20MHz), Rate MCS0

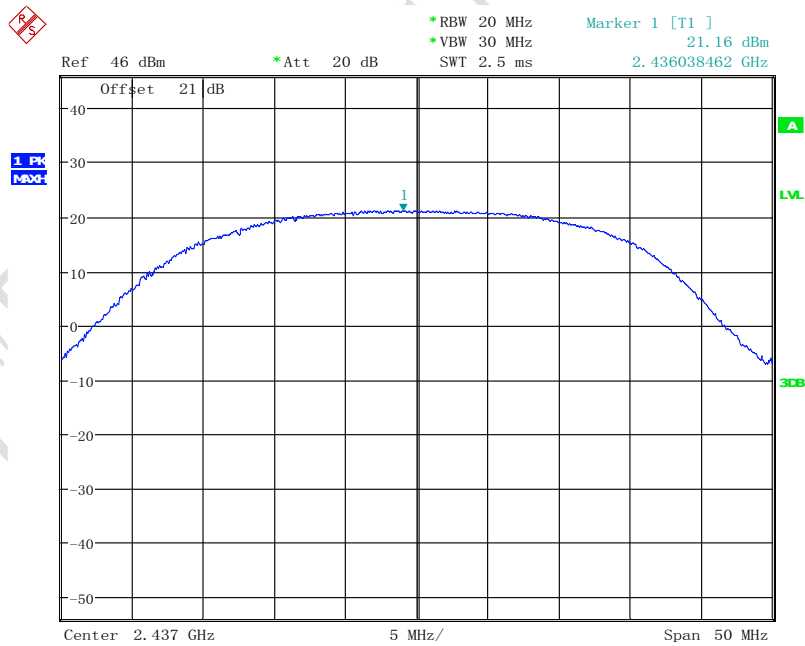

Date: 15. APR. 2015 14:54:31

Fig.46 Conducted Output Power CH6, 11n(20MHz), Rate MCS1

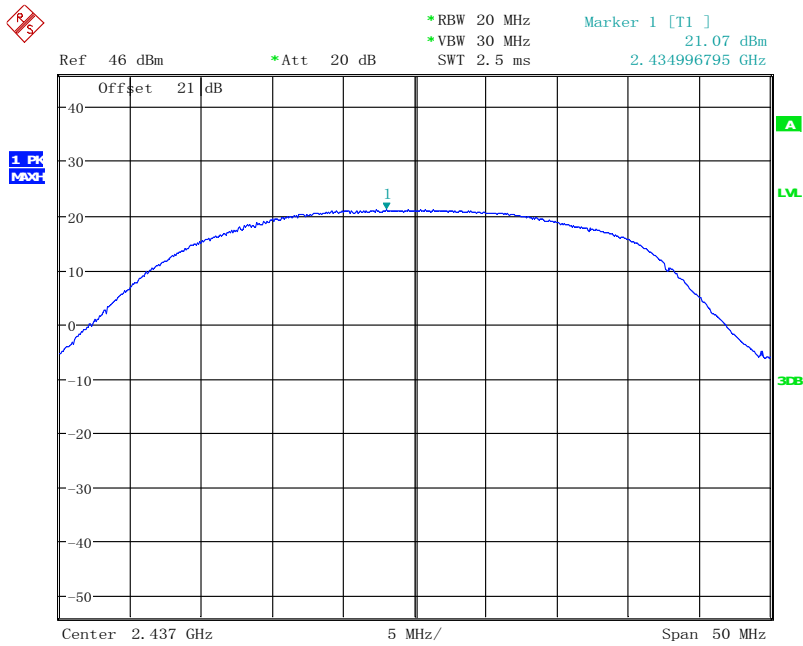

Date: 15. APR. 2015 14:54:43

Fig.47 Conducted Output Power CH6, 11n(20MHz), Rate MCS2

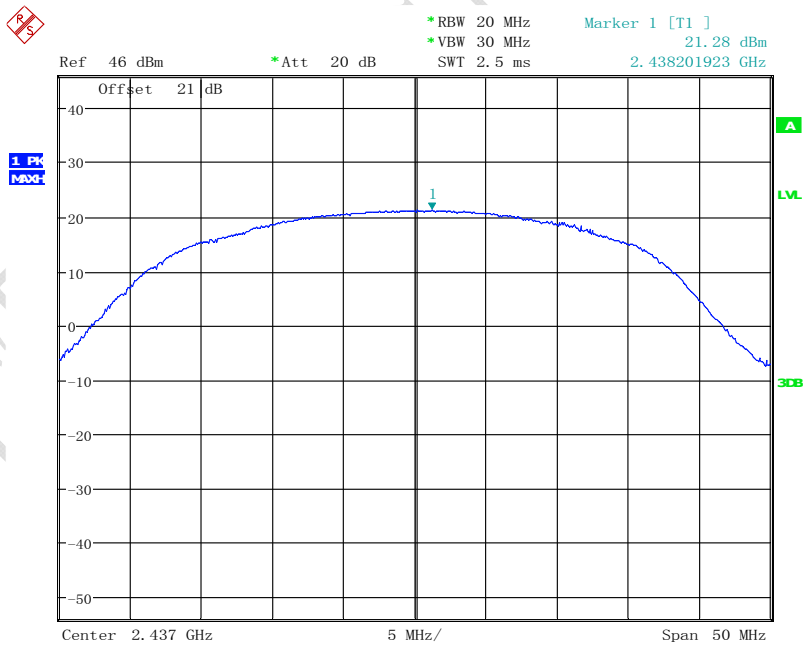

Date: 15. APR. 2015 14:54:54

Fig.48 Conducted Output Power CH6, 11n(20MHz), Rate MCS3

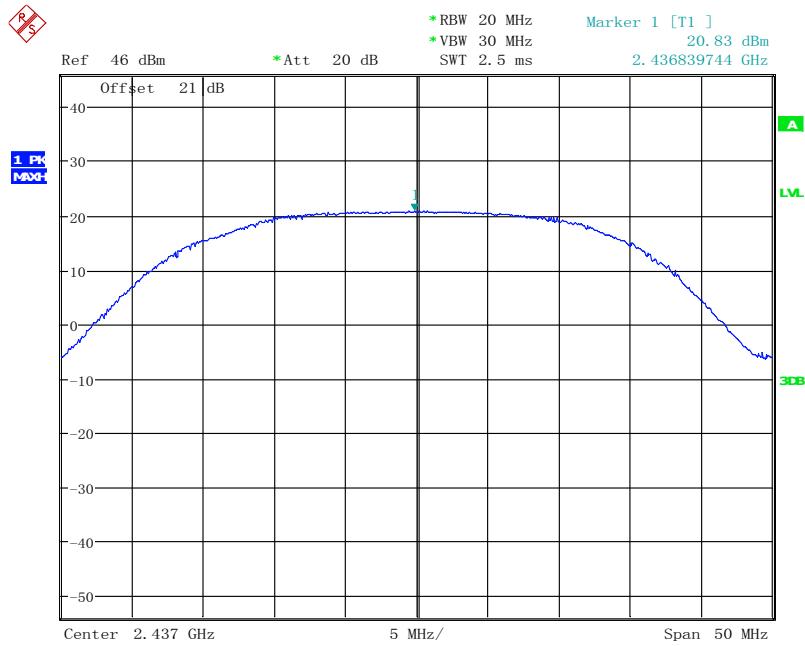

Date: 15. APR. 2015 14:55:06

Fig.49 Conducted Output Power CH6, 11n(20MHz), Rate MCS4

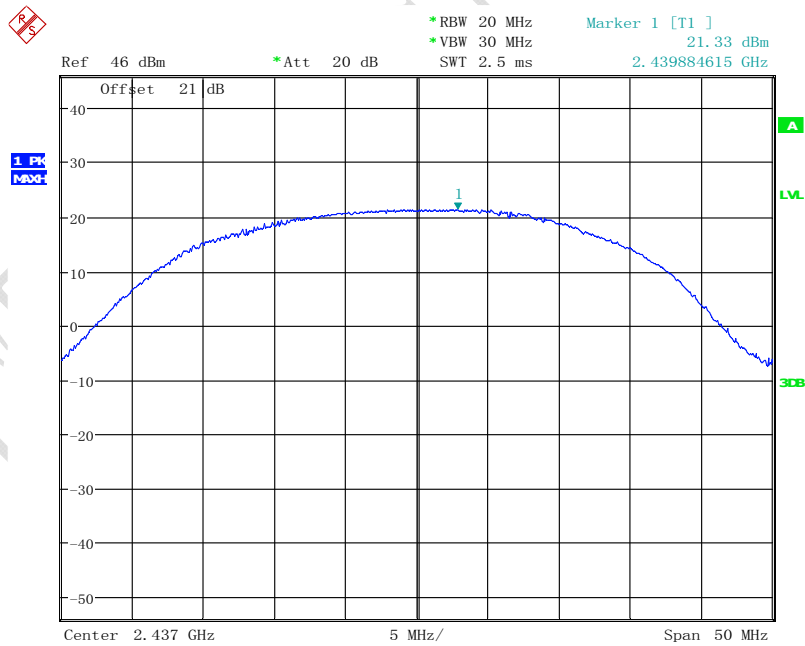

Date: 15. APR. 2015 14:55:17

Fig.50 Conducted Output Power CH6, 11n(20MHz), Rate MCS5

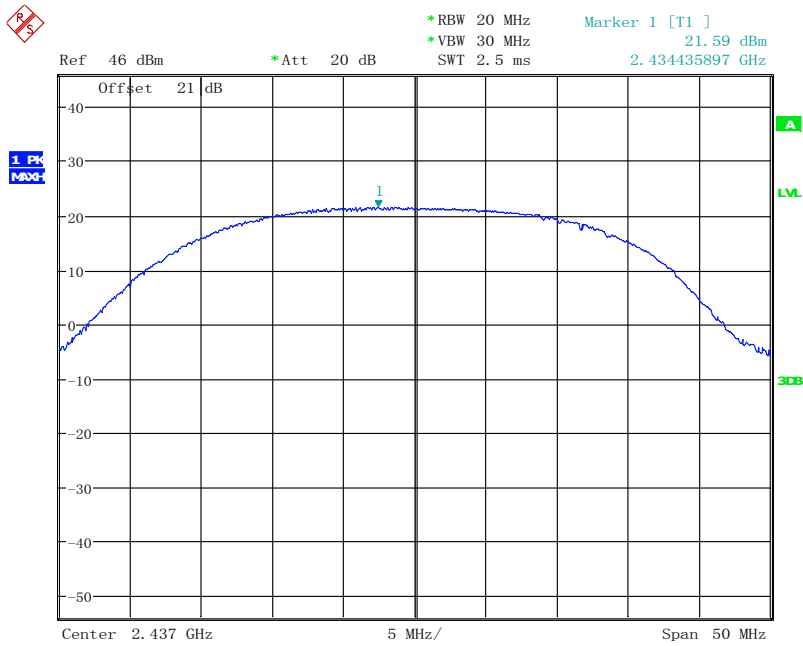

Date: 15. APR. 2015 14:55:30

Fig.51 Conducted Output Power CH6, 11n(20MHz), Rate MCS6

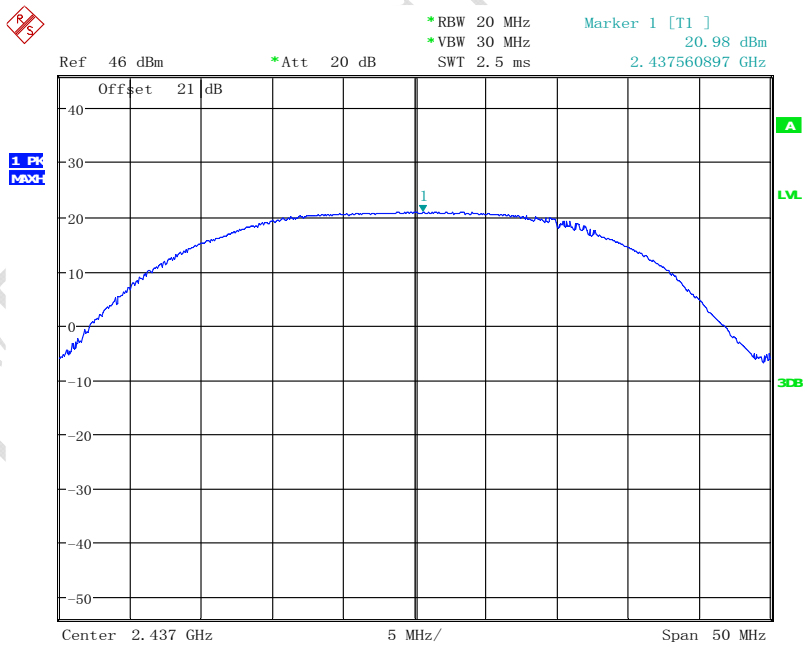

Date: 15. APR. 2015 14:55:41

Fig.52 Conducted Output Power CH6, 11n(20MHz), Rate MCS7

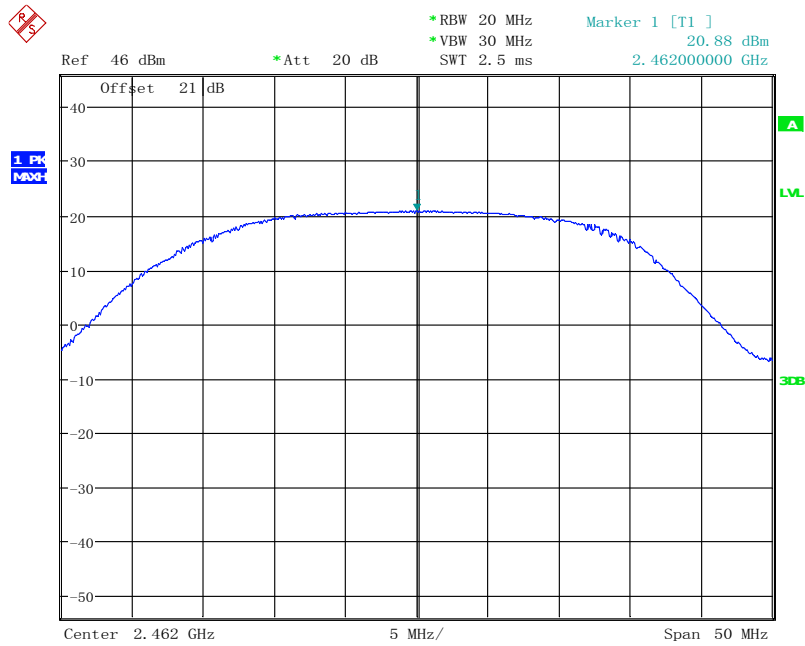

Date: 15. APR. 2015 14:58:40

Fig.53 Conducted Output Power CH11, 11n(20MHz), Rate MCS0

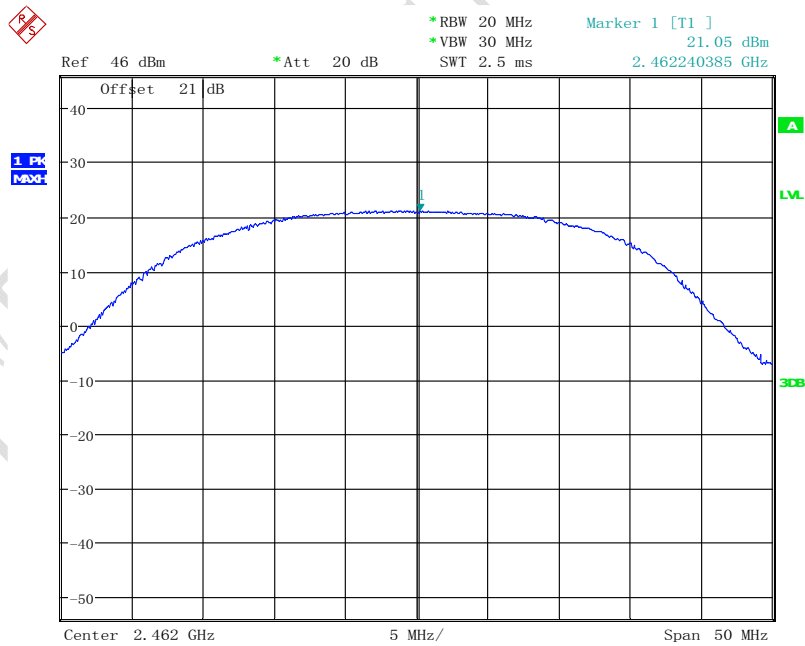

Date: 15. APR. 2015 14:58:51

Fig.54 Conducted Output Power CH11, 11n(20MHz), Rate MCS1

FCC Parts 15 subpart C, ANSI C63.10-2013  
Equipment: Ilium X100

REPORT NO.: B15X50034-FCC-Wifi\_Rev1

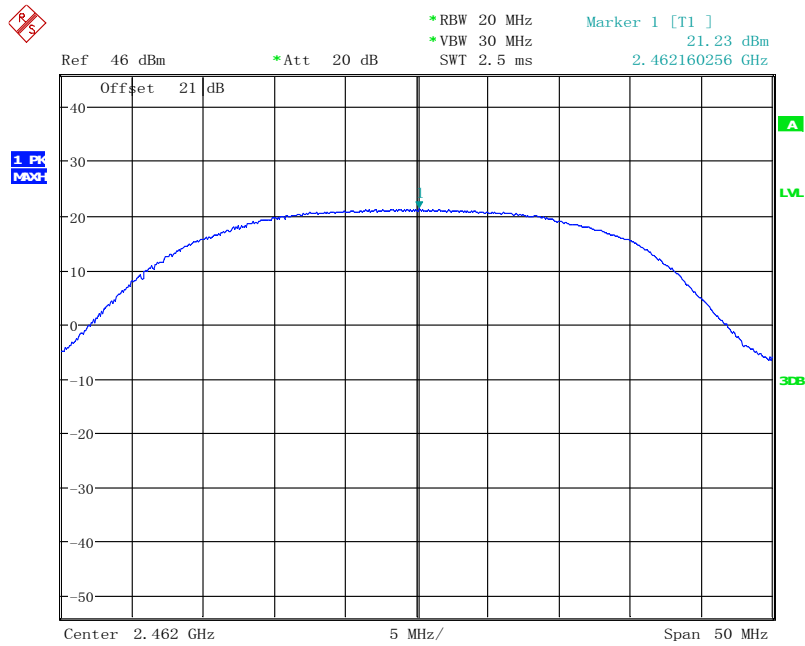

Date: 15. APR. 2015 14:59:02

Fig.55 Conducted Output Power CH11, 11n(20MHz), Rate MCS2

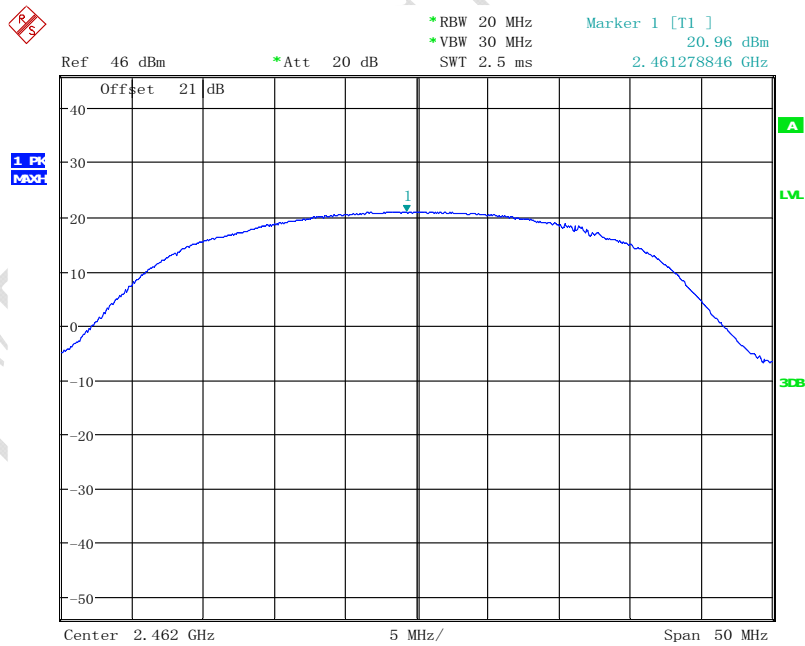

Date: 15. APR. 2015 14:59:15

Fig.56 Conducted Output Power CH11, 11n(20MHz), Rate MCS3

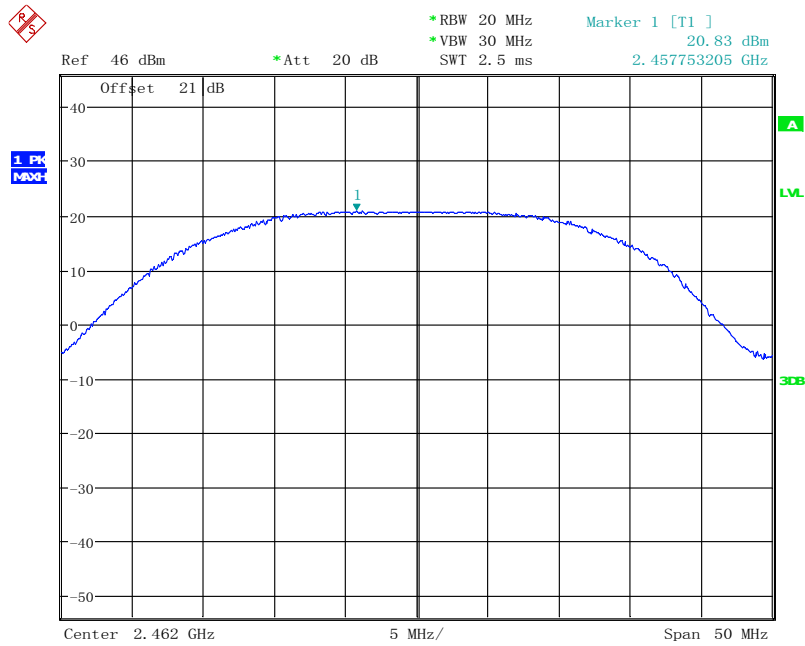

Date: 15. APR. 2015 14:59:27

Fig.57 Conducted Output Power CH11, 11n(20MHz), Rate MCS4

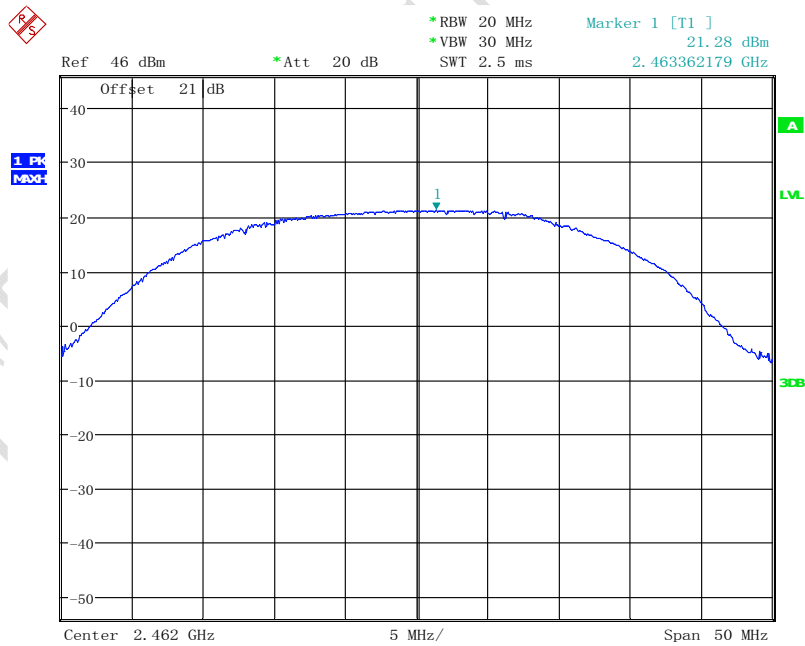

Date: 15. APR. 2015 14:59:38

Fig.58 Conducted Output Power CH11, 11n(20MHz), Rate MCS5



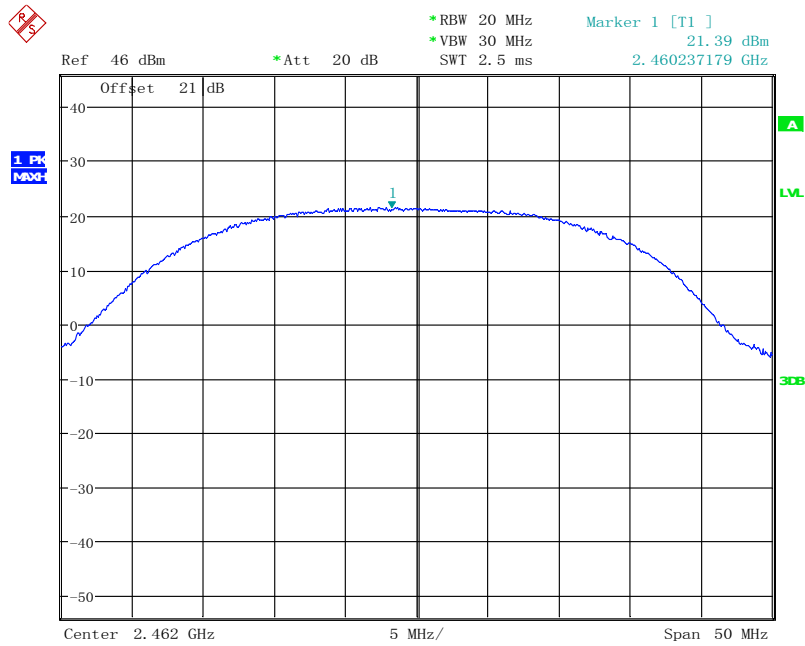

Date: 15. APR. 2015 14:59:50

Fig.59 Conducted Output Power CH11, 11n(20MHz), Rate MCS6

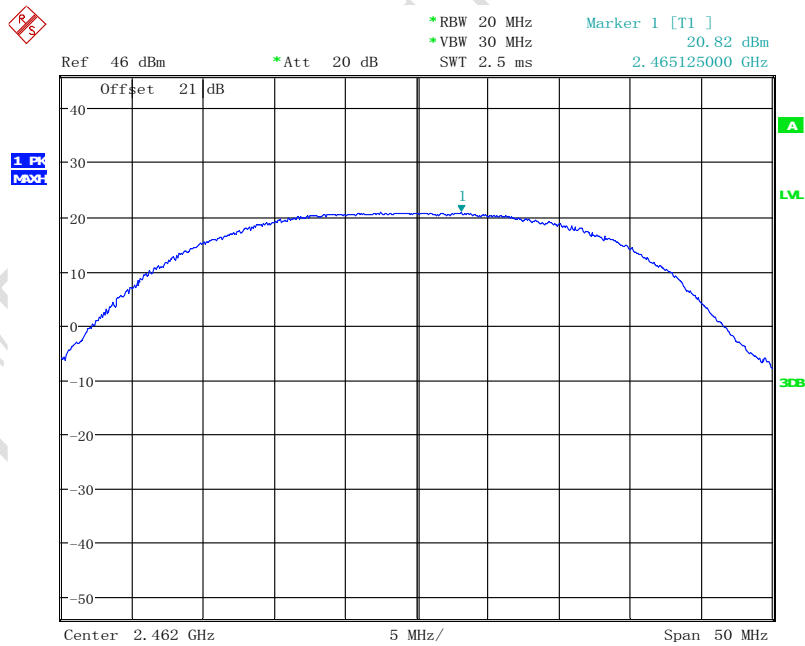

Date: 15. APR. 2015 15:00:03

Fig.60 Conducted Output Power CH11, 11n(20MHz), Rate MCS7

### 4.2 Maximum Average Output Power-conducted

<b>Date of Tests</b>	2015-01-23~2015-04-15					
<b>Test conditions:</b>	Ambient Temperature:15°C-35°C Relative Humidity:30%-60% Air pressure: 86-106kPa					
<b>Test Results:</b>	Pass					
<b>Test equipment Used:</b>						
<b>Number</b>	<b>Description</b>	<b>Manufacturer</b>	<b>Model Number</b>	<b>Serial Number</b>	<b>Cal Due</b>	<b>State</b>
1	EMI Test Receiver	R/S	ESU40	100350	2016-03-07	Normal

#### 4.2.1 Measurement Limit

Standard	Limit (dBm)
FCC Part 15.247(b)	< 30

#### 4.2.2 Test procedure

1. Measure the duty cycle D of the transmitter output signal as described in 11.6.
  2. the duty cycle D of the transmitter output signal is  $\geq 98\%$
- The measurement is according to ANSI C63.10 clause 11.9
3. The output power of EUT was connected to the spectrum analyzer. The path loss was compensated to the results for each measurement.
  4. Set span to at least 1.5 times the OBW.
  5. Set RBW = 1% to 5% of the OBW, not to exceed 1 MHz.
  6. Set VBW  $\geq [3 * RBW]$ .
  7. Number of points in sweep  $\geq [2 * span / RBW]$ . (This gives bin-to-bin spacing  $\leq RBW / 2$ , so that narrowband signals are not lost between frequency bins.)
  8. Sweep time = auto.
  9. Detector = RMS (i.e., power averaging), if available. Otherwise, use sample detector mode

#### 4.2.3 Measurement Results:

##### 802.11b/g mode

Mode	Data Rate(Mbps)	Teat Result(dBm)			Conclusion
		Ch1	Ch6	Ch11	
802.11b	1	17.25	17.43	17.54	Pass
	2	17.17	17.57	17.52	Pass
	5.5	17.56	17.58	17.63	Pass
	11	17.43	17.64	17.62	Pass
802.11g	6	14.75	14.84	14.88	Pass
	9	14.58	15.12	15.11	Pass
	12	14.56	14.90	14.69	Pass

	18	14.53	14.88	14.50	Pass
	24	14.47	14.91	14.56	Pass
	36	14.27	14.84	14.47	Pass
	48	14.52	14.91	14.45	Pass
	54	14.14	14.92	14.55	Pass

802.11n mode

Mode	Data Rate(Mbps)	Teat Result(dBm)			Conclusion
		Ch1	Ch6	Ch11	
802.11n (20MHz)	MCS0	14.60	14.94	14.43	Pass
	MCS1	14.71	14.90	14.52	Pass
	MCS2	14.43	14.95	14.60	Pass
	MCS3	14.54	14.96	14.65	Pass
	MCS4	14.49	14.99	14.78	Pass
	MCS5	14.30	14.85	14.59	Pass
	MCS6	14.33	14.82	14.72	Pass
	MCS7	14.48	14.70	14.74	Pass
802.11n (40MHz)	MCS0	/	/	/	/
	MCS1	/	/	/	/
	MCS2	/	/	/	/
	MCS3	/	/	/	/
	MCS4	/	/	/	/
	MCS5	/	/	/	/
	MCS6	/	/	/	/
	MCS7	/	/	/	/

Conclusion: PASS

### 4.3 Peak Power Spectral Density

<b>Date of Tests</b>		2015-01-26-2015-01-28				
<b>Test conditions:</b>		Ambient Temperature:15°C-35°C Relative Humidity:30%-60% Air pressure: 86-106kPa				
<b>Test Results:</b>		Pass				
<b>Test equipment Used:</b>						
Number	Description	Manufacturer	Model Number	Serial Number	Cal Due	State
1	EMI Test Receiver	R/S	ESU40	100350	2015-03-07	Normal

#### 4.3.1 Measurement Limit:

Standard	Limit
FCC CFR Part 15.247(e)	< 8dBm/3 KHz

#### 4.3.2 Test procedures

The measurement is according to ANSI C63.10 clause 11.10.

1. The output power of EUT was connected to the spectrum analyzer. The path loss was compensated to the results for each measurement.
2. Enable EUT transmitter maximum power continuously.
3. Set analyzer center frequency to DTS channel center frequency.
4. Set the span to 1.5 times the DTS bandwidth.
5. Set the RBW to  $3\text{ kHz} \leq \text{RBW} \leq 100\text{ kHz}$ .
6. Set the VBW  $\geq [3 \times \text{RBW}]$ .
7. Detector = peak.
8. Sweep time = auto couple.
9. Trace mode = max hold.
10. Allow trace to fully stabilize.
11. Use the peak marker function to determine the maximum amplitude level within the RBW.
12. If measured value exceeds requirement, then reduce RBW (but no less than 3 kHz) and repeat.

#### 4.3.3 Measurement Results:

##### 802.11b/g mode

Mode	Power Spectral Density(dBm/3kHz)			Conclusion
	Ch1	Ch6	Ch11	
802.11b	-6.04	-5.99	-9.92	Pass
802.11g	-5.63	-5.24	-7.71	Pass

##### 802.11n mode

FCC Parts 15 subpart C, ANSI C63.10-2013  
Equipment: Ilium X100

REPORT NO.: B15X50034-FCC-Wifi\_Rev1

Mode	Power Spectral Density(dBm/3kHz)			Conclusion
	Ch1	Ch6	Ch11	
802.11n(20MHz)	-5.00	-5.15	-7.51	Pass
802.11n(40MHz)	/	/	/	/

Test figure as below:

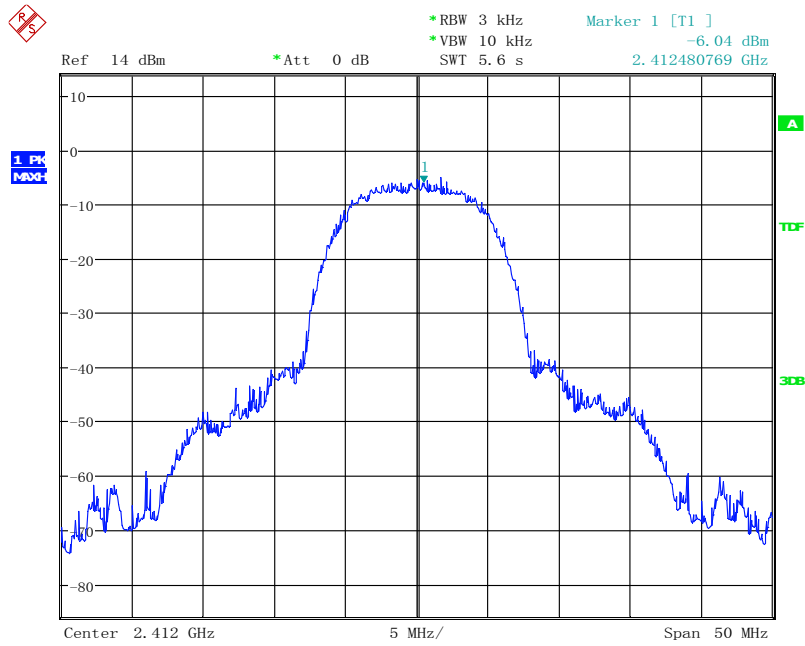

Date: 26. JAN. 2015 18:57:12

Fig.61 Power spectral density: CH1,11b

FCC Parts 15 subpart C, ANSI C63.10-2013  
Equipment: Ilium X100

REPORT NO.: B15X50034-FCC-Wifi\_Rev1

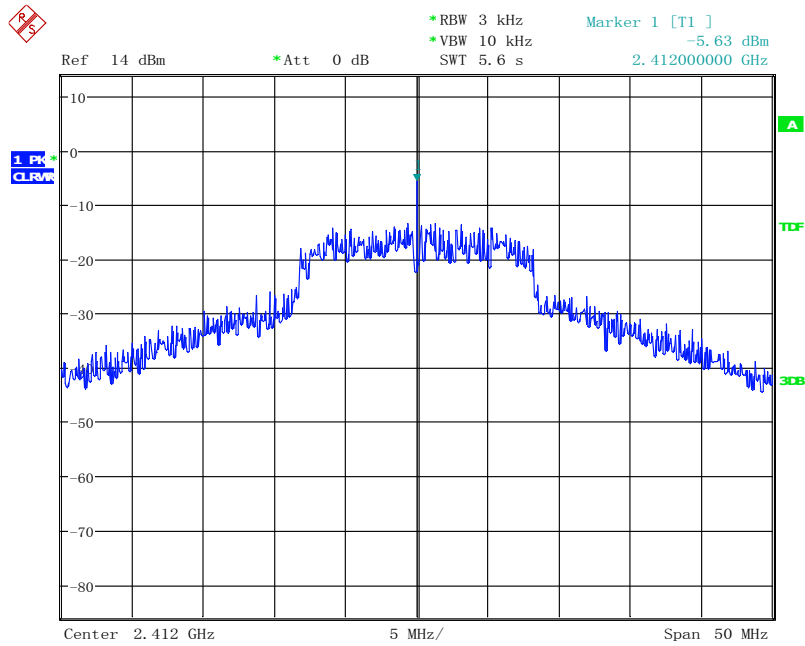

Date: 26. JAN. 2015 19:09:07

Fig.62 Power spectral density: CH1,11g

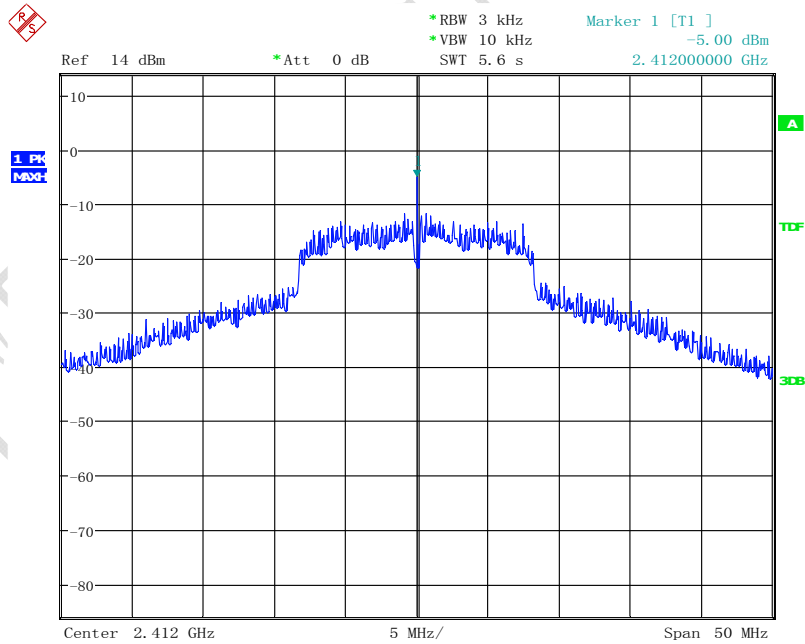

Date: 26. JAN. 2015 19:10:40

Fig.63 Power spectral density: CH1,11n(20MHz)

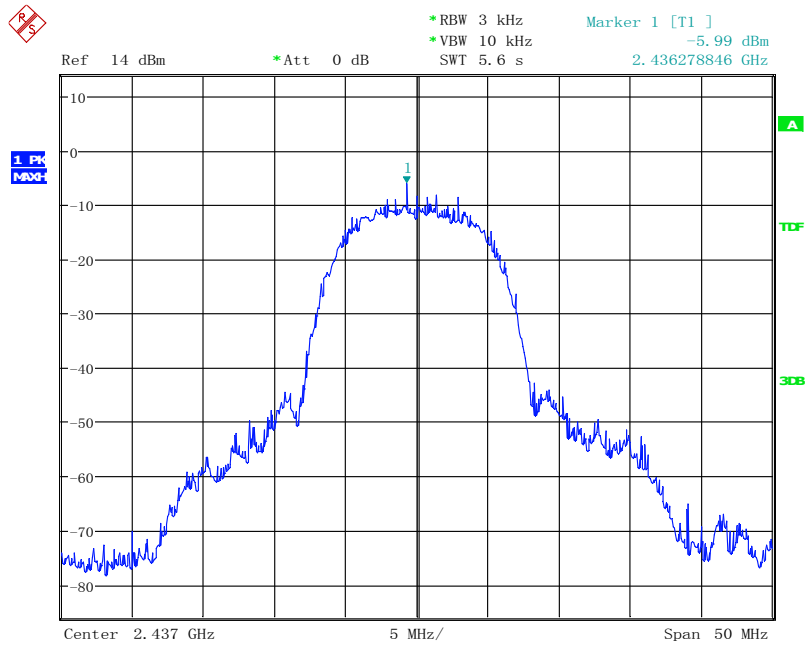

Date: 28. JAN. 2015 00:08:23

Fig.64 Power spectral density: CH6,11b

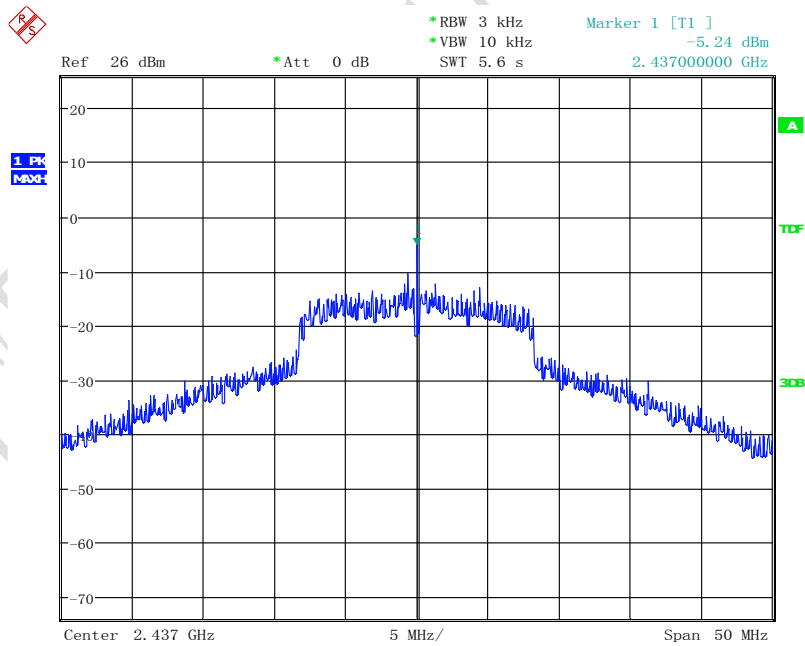

Date: 28. JAN. 2015 00:07:28

Fig.65 Fig.66 Power spectral density: CH6,11g

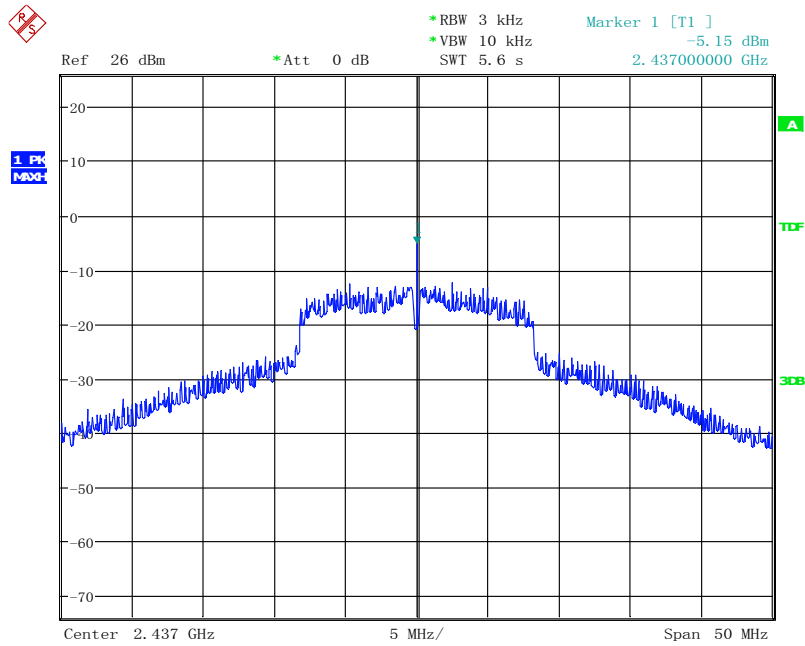

Date: 28. JAN. 2015 00:06:31

Fig.66 Power spectral density: CH6,11n(20MHz)

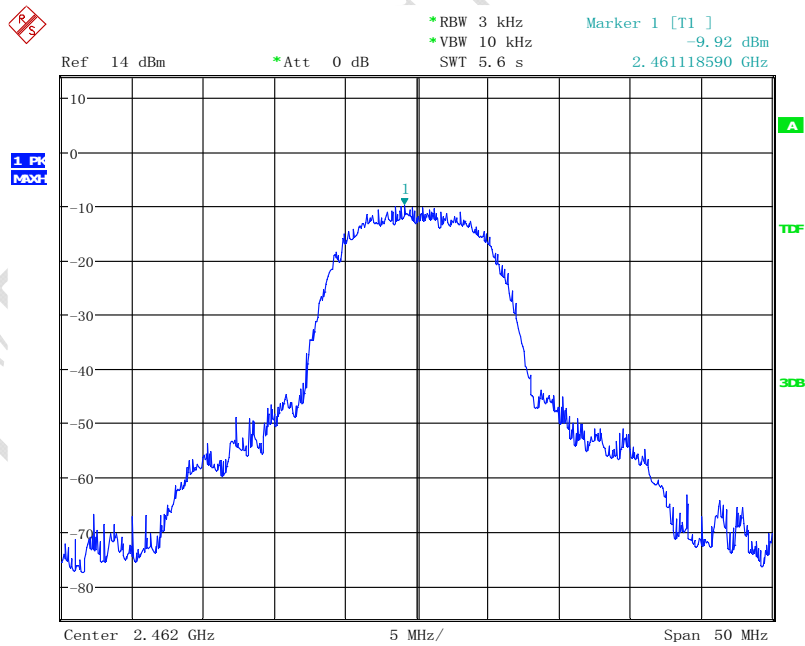

Date: 28. JAN. 2015 00:09:14

Fig.67 Power spectral density: CH11,11b



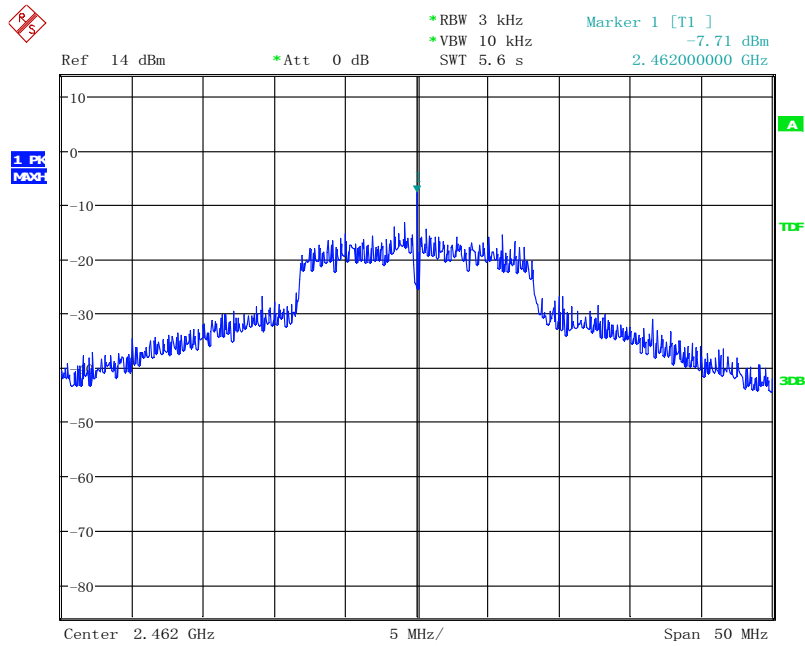

Date: 28. JAN. 2015 00:09:54

Fig.68 Power spectral density: CH11,11g

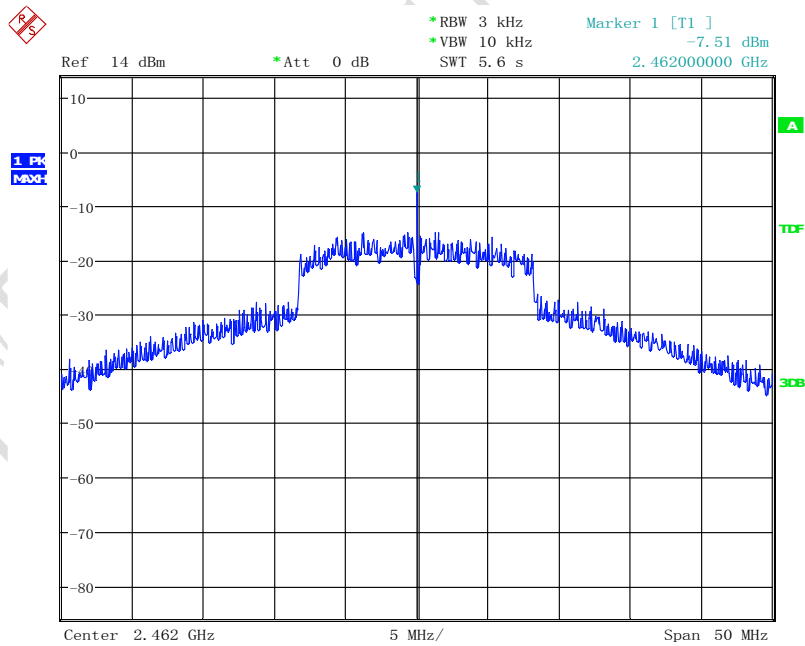

Date: 28. JAN. 2015 00:10:49

Fig.69 Power spectral density: CH11,11n(20MHz)

### 4.4 6dB Bandwidth

<b>Date of Test</b>		2015-01-27				
<b>Test conditions:</b>		Ambient Temperature:15°C-35°C Relative Humidity:30%-60% Air pressure: 86-106kPa				
<b>Test Results:</b>		Pass				
<b>Test equipment Used:</b>						
Number	Description	Manufacturer	Model Number	Serial Number	Cal Due	State
1	EMI Test Receiver	R/S	ESU40	100350	2015-03-07	Normal

#### 4.4.1 Measurement Limit:

Standard	Limit(KHz)
FCC 47 CFR Part 15.247(a)	≥500

#### 4.4.2 Test procedures

The measurement is according to ANSI C63.10 clause 11.8.

1. The output power of EUT was connected to the spectrum analyzer. The path loss was compensated to the results for each measurement.
2. Enable EUT transmitter maximum power continuously.
3. Set RBW = 100 kHz.
4. Set the VBW  $\geq [3 \times \text{RBW}]$ .
5. Detector = peak.
6. Trace mode = max hold.
7. Sweep = auto couple.
8. Allow the trace to stabilize.
9. Measure the maximum width of the emission that is constrained by the frequencies associated with the two outermost amplitude points (upper and lower frequencies) that are attenuated by 6 dB relative to the maximum level measured in the fundamental emission.

#### 4.4.3 Measurement Result:

##### 802.11b/g mode

Mode	Occupied 6dB Bandwidth(MHz)			Conclusion
	Ch1	Ch6	Ch11	
802.11b	9.455	10.176	10.176	Pass
802.11g	16.266	16.266	16.266	Pass

##### 802.11n mode

Mode	Occupied 6dB Bandwidth(MHz)			Conclusion
	Ch1	Ch6	Ch11	

FCC Parts 15 subpart C, ANSI C63.10-2013  
Equipment: Ilium X100

REPORT NO.: B15X50034-FCC-Wifi\_Rev1

802.11n(20MHz)	16.026	15.946	16.587	Pass
802.11n(40MHz)	/	/	/	/

**Conclusion: PASS**

Test figure as below:

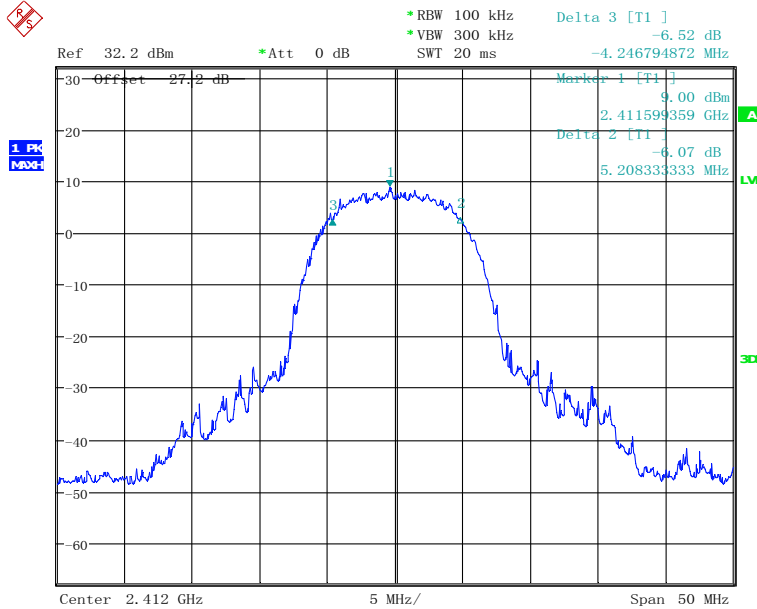

Date: 27. JAN. 2015 23:03:32

Fig.70 6dB Bandwidth: Ch1,11b

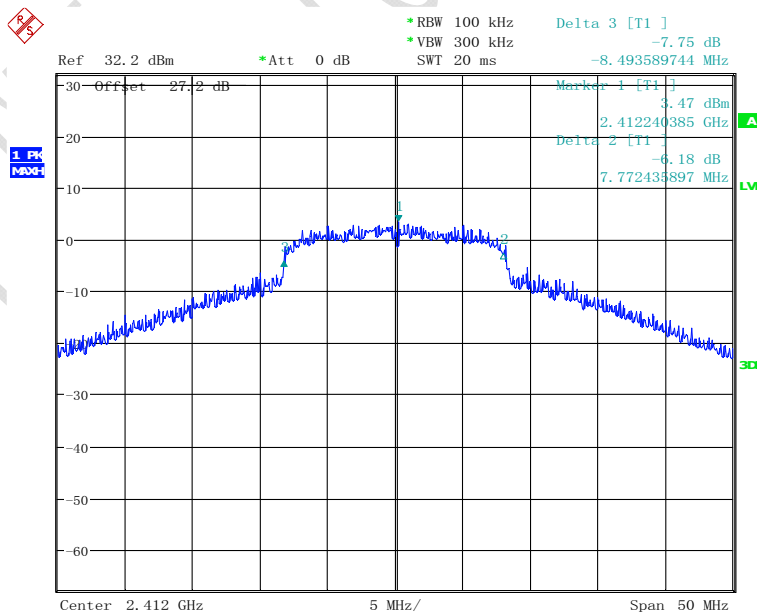

Date: 27. JAN. 2015 23:05:45

Fig.71 6dB Bandwidth: Ch1,11g

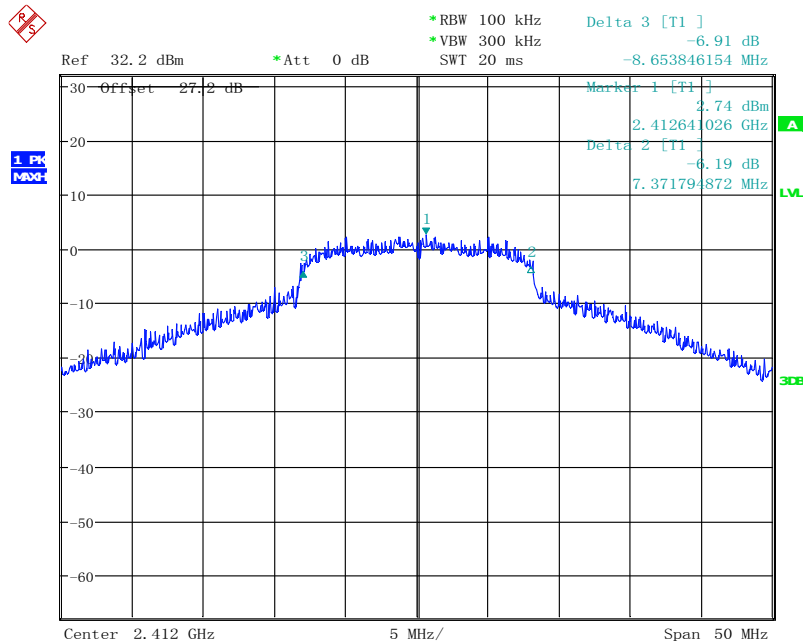

Date: 27. JAN. 2015 23:09:58

Fig.72 6dB Bandwidth: Ch1,11n(20MHz)

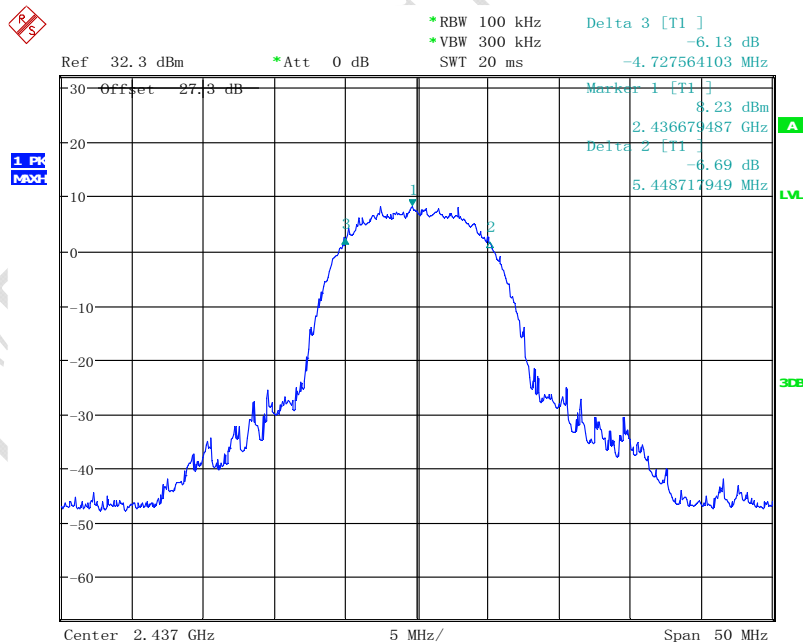

Date: 27. JAN. 2015 22:54:48

Fig.73 6dB Bandwidth: Ch6,11b

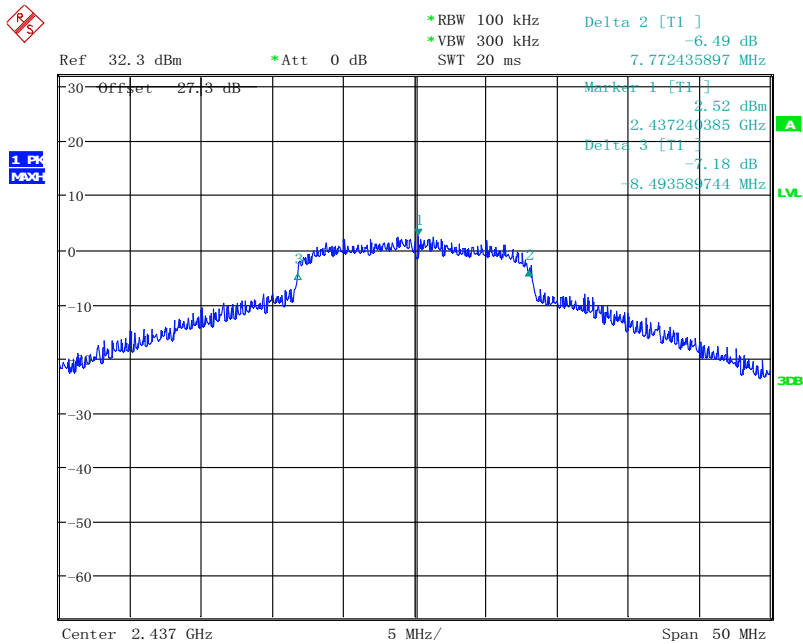

Date: 27. JAN. 2015 22:52:21

Fig.74 6dB Bandwidth: Ch6,11g

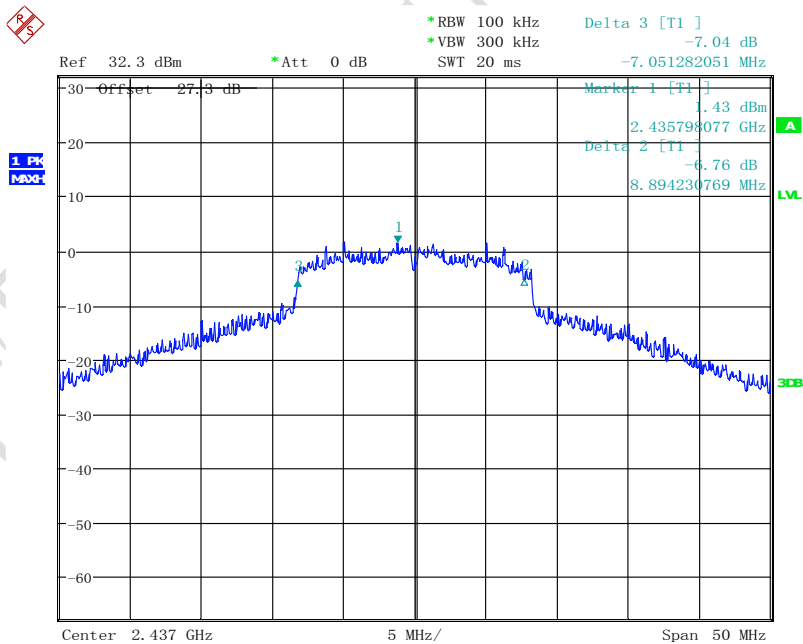

Date: 27. JAN. 2015 22:50:03

Fig.75 6dB Bandwidth: Ch6,11n(20MHz)

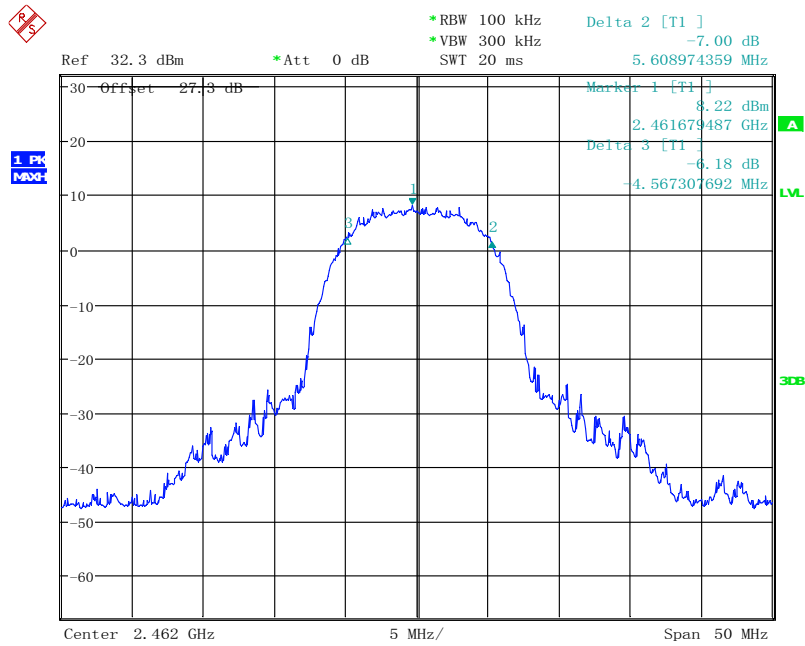

Date: 27. JAN. 2015 20:52:46

Fig.76 6dB Bandwidth: Ch11,11b

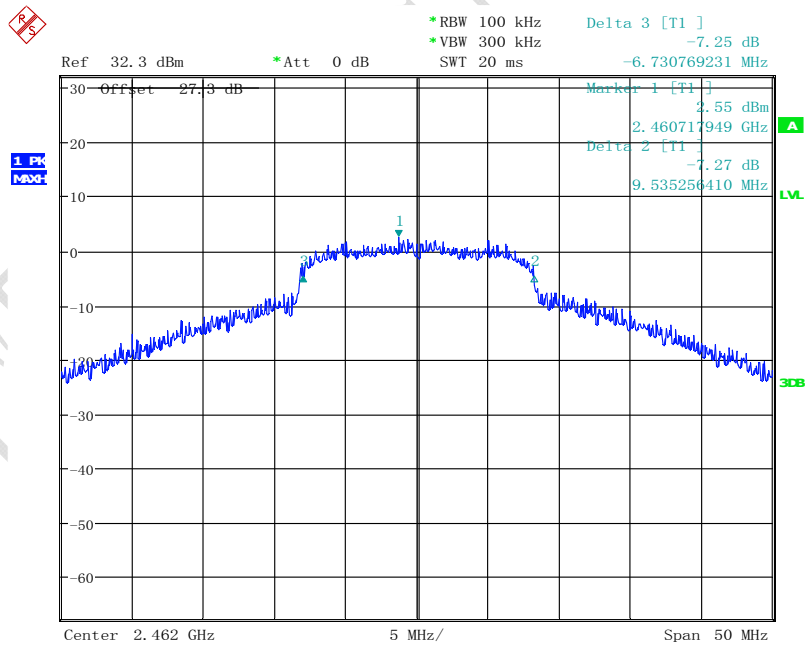

Date: 27. JAN. 2015 20:48:54

Fig.77 6dB Bandwidth: Ch11,11g

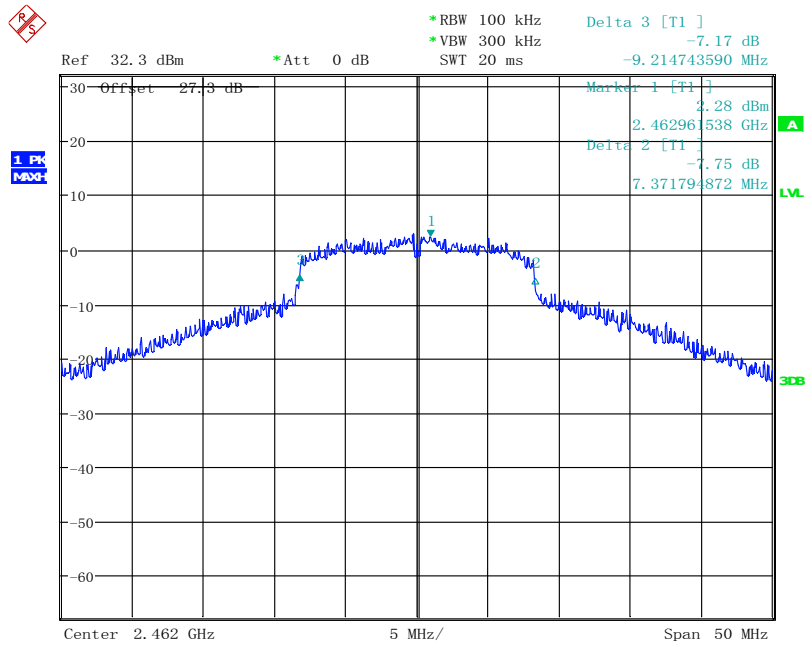

Date: 27. JAN. 2015 20:46:26

Fig.78 6dB Bandwidth: Ch11,11n(20MHz)

### 4.5 Frequency Band Edges

<b>Date of Test</b>		2015-04-14				
<b>Test conditions:</b>		Ambient Temperature:15°C-35°C Relative Humidity:30%-60% Air pressure: 86-106kPa				
<b>Test Results:</b>		Pass				
<b>Test equipment Used:</b>						
Number	Description	Manufacturer	Model Number	Serial Number	Cal Due	State
1	EMI Test Receiver	R/S	ESU40	100350	2015-03-07	Normal

#### 4.5.1 Measurement Limit:

Standard	Limited(dBuV/m)	
FCC 47 CFR Part 15.247(d)	Peak	74
	Average	54

#### 4.5.2 Test procedure

The measurement is according to ANSI C63.10 clause11.13.

- Span: Wide enough to capture the peak level of the emission operating on the channel closest to the band edge, as well as any modulation products that fall outside of the authorized band of operation.
- Reference level offset: Corrected for gains and losses of test antenna factor, preamp gain and cable loss, so as to indicate field strength, in units of dBμV/m at 3 m, directly on the instrument display. Alternatively, the reference level offset may be set to zero and calculations shall be provided showing the conversion of raw measured data to the field strength in dBμV/m at 3 m.
- Reference level: As required to keep the signal from exceeding the maximum spectrum analyzer input mixer level for linear operation. In general, the peak of the spectral envelope shall be more than [10 log (OBW/RBW)] below the reference level. Specific guidance is given in 4.1.5.2..
- Attenuation: Auto (at least 10 dB preferred).
- Sweep time: Coupled.
- Resolution bandwidth: Above 1 GHz: 1 MHz
- Video bandwidth: VBW for Peak, Quasi-peak, or Average Detector Function: 3× RBW
- Detector (unless specified otherwise): Peak and average above 1 GHz
- Trace: Max hold for final measurement; a combination of two traces, clear-write and max hold, is recommended for maximizing the emission.

#### 4.5.3 Measurement results



**802.11b/g mode**

mode	Channel	Test Results(dBuV/m)			Conclusion
802.11b	1	Peak	2390.000MHz	39.904	Pass
		Average	2390.000MHz	30.702	
		Fig.79			
802.11b	11	Peak	2489.500MHz	49.222	Pass
		Average	2489.590MHz	34.556	
		Fig.80			
802.11g	1	Peak	2390.000MHz	41.937	Pass
		Average	2390.000MHz	31.875	
		Fig.81			
802.11g	11	Peak	2489.860MHz	49.356	Pass
		Average	2489.788MHz	34.717	
		Fig.82			

**802.11n mode**

mode	Channel	Test Results(dBuV/m)			Conclusion
802.11n (20MHz)	1	Peak	2390.000MHz	44.165	Pass
		Average	2390.000MHz	33.836	
		Fig.83			
802.11n (20MHz)	11	Peak	2491.510MHz	49.650	Pass
		Average	2491.414MHz	34.422	
		Fig.84			

**Conclusion: PASS**

Test figure as below:

BAND EDGERE 1GHz-3GHz 2483.5-2500

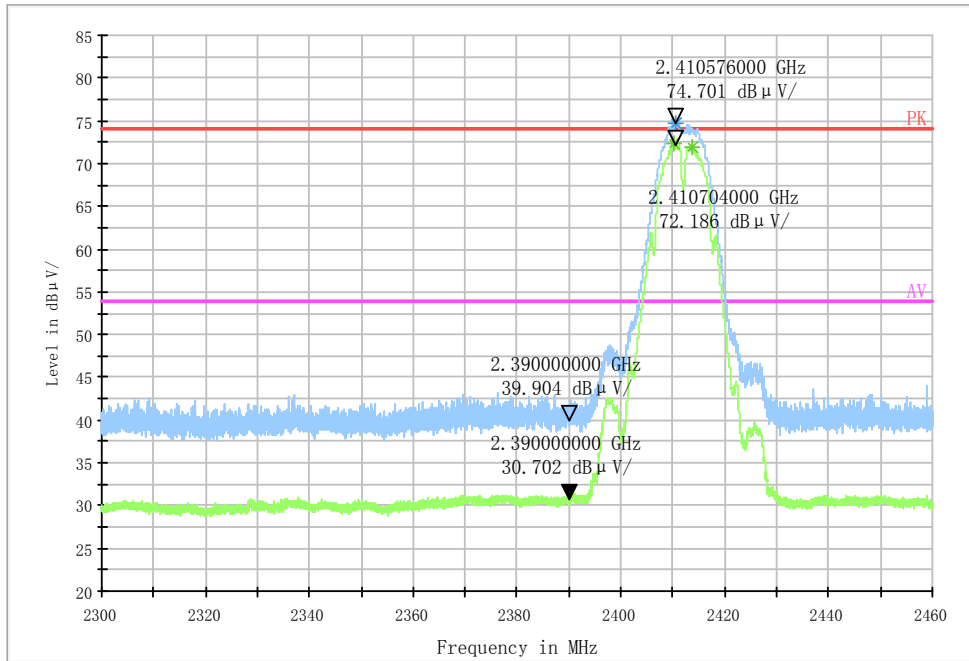

Fig.79 Frequency Band Edge: Ch1,11b

BAND EDGERE 1GHz-3GHz 2483.5-2500

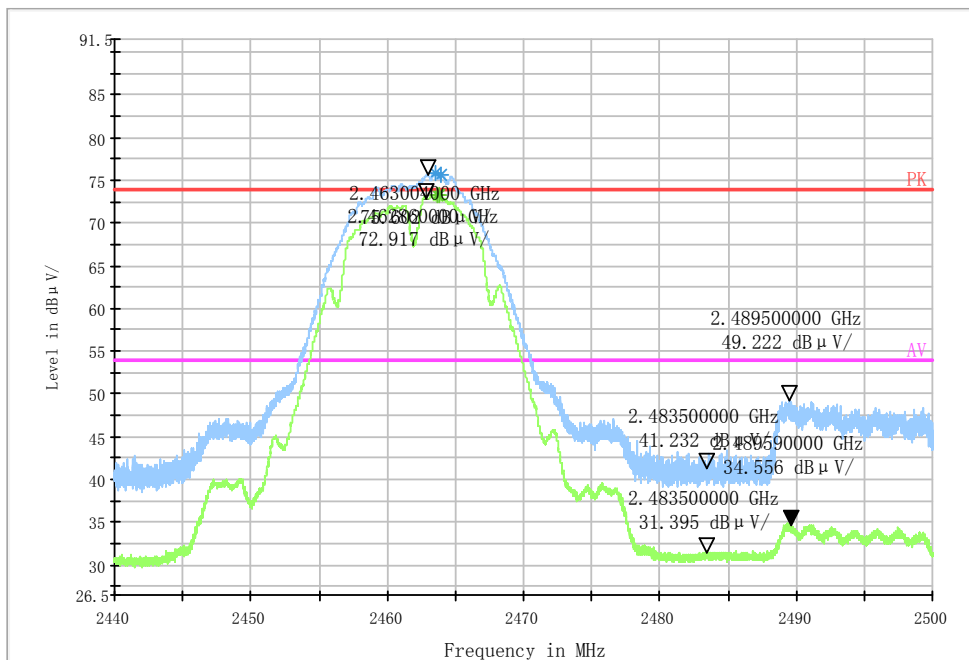

Fig.80 Frequency Band Edge: Ch11,11b

BAND EDGERE 1GHz-3GHz 2483.5-2500

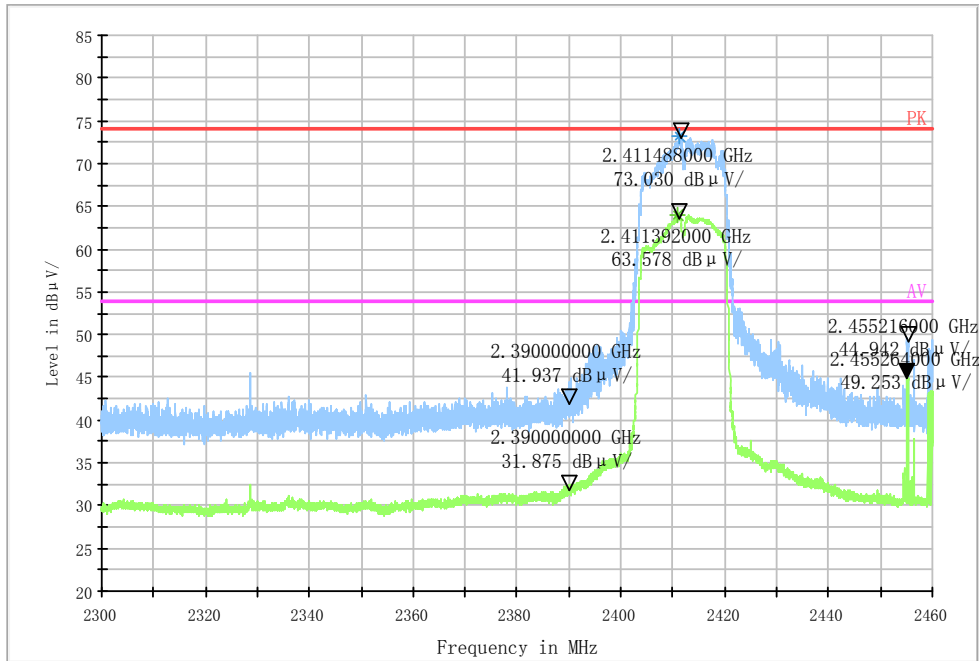

Fig.81 Frequency Band Edge: Ch1,11g

BAND EDGERE 1GHz-3GHz 2483.5-2500

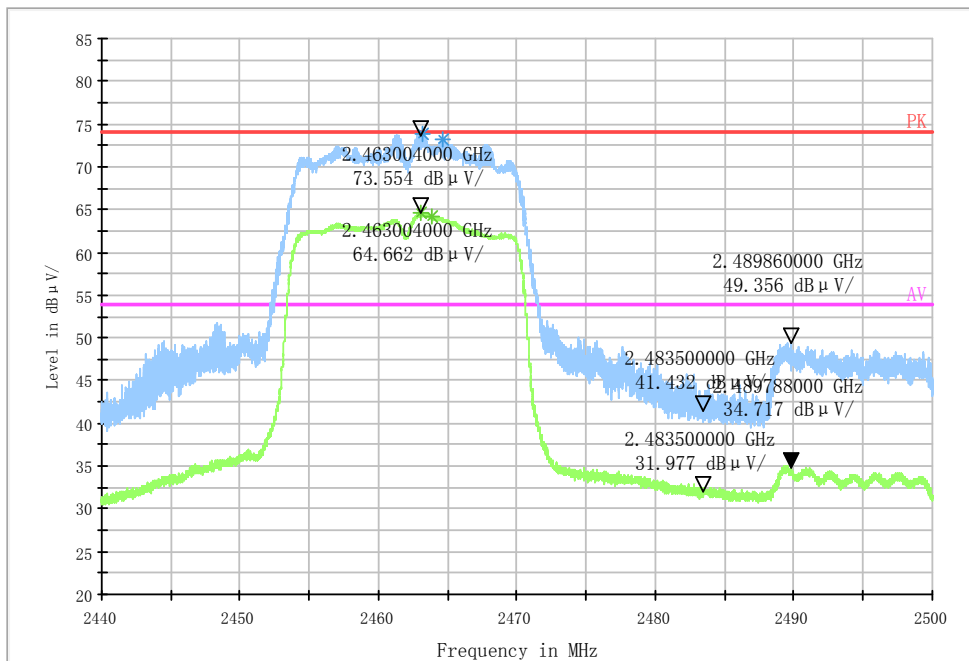

Fig.82 Frequency Band Edge: Ch11,11g

BAND EDGERE 1GHz-3GHz 2483.5-2500

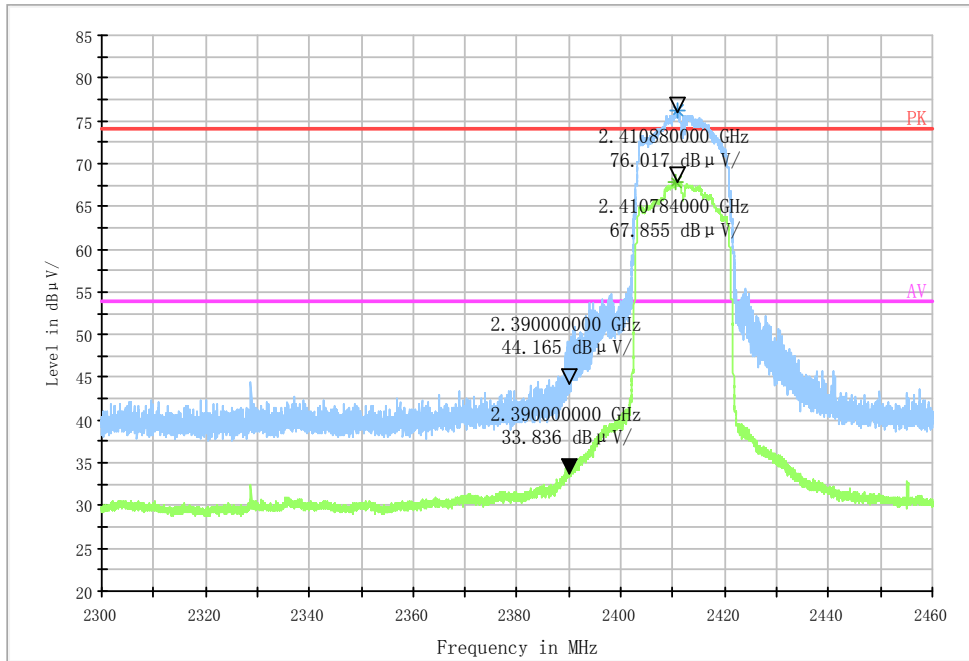

Fig.83 Frequency Band Edge: Ch1,11n(20MHz)

BAND EDGERE 1GHz-3GHz 2483.5-2500

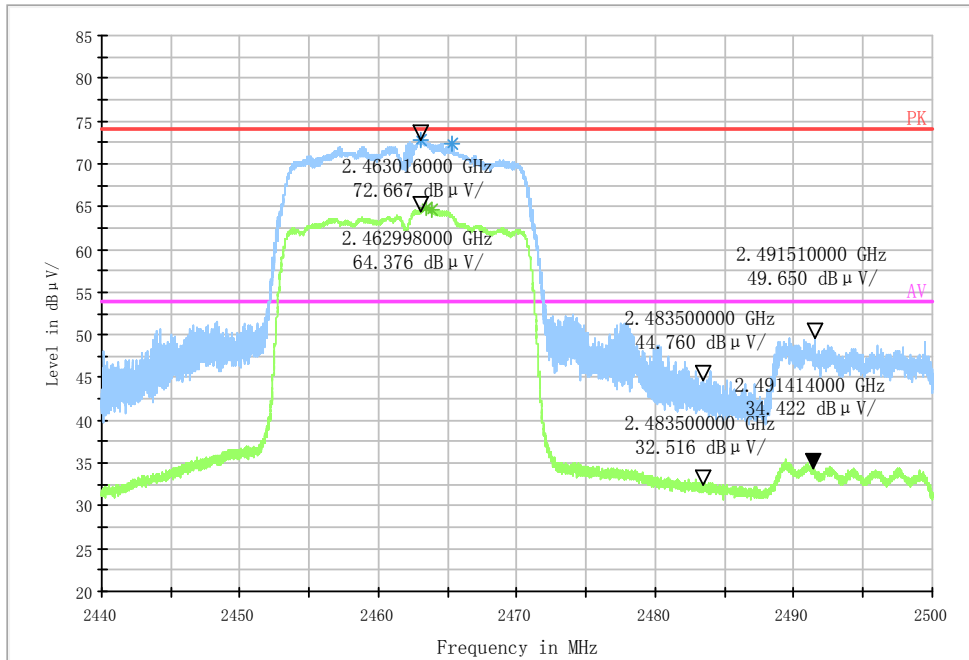

Fig.84 Frequency Band Edge: Ch11,11n(20MHz)

### 4.6 Conducted Emission

<b>Date of Test</b>	2015-01-26-2015-01-27					
<b>Test conditions:</b>	Ambient Temperature:15°C-35°C Relative Humidity:30%-60% Air pressure: 86-106kPa					
<b>Test Results:</b>	Pass					
<b>Test equipment Used:</b>						
<b>Number</b>	<b>Description</b>	<b>Manufacturer</b>	<b>Model Number</b>	<b>Serial Number</b>	<b>Cal Due</b>	<b>State</b>
1	EMI Test Receiver	R/S	ESU40	100350	2015-03-07	Normal

#### 4.6.1 Measurement Limit:

Standard	Limit
FCC 47 CFR Part15.247 (d)	20dB below peak output power in 100KHz bandwidth

#### 4.6.2 Test procedures

This measurement is according to ANSI C63.10 clause 11.11.

1. The output power of EUT was connected to the spectrum analyzer. The path loss was compensated to the results for each measurement.
2. Enable EUT transmitter maximum power continuously.

Reference level measurement

3. Set instrument center frequency to DTS channel center frequency.
4. Set the span to  $\geq 1.5$  times the DTS bandwidth.
5. Set the RBW = 100 kHz.
6. Set the VBW  $\geq [3 \times \text{RBW}]$ .
7. Detector = peak.
8. Sweep time = auto couple.
9. Trace mode = max hold.
10. Allow trace to fully stabilize.
11. Use the peak marker function to determine the maximum PSD level.

Emission level measurement

12. Set the center frequency and span to encompass frequency range to be measured.
13. Set the RBW = 100 kHz.
14. Set the VBW  $\geq [3 \times \text{RBW}]$ .
15. Detector = peak.
16. Sweep time = auto couple.
17. Trace mode = max hold.
18. Allow trace to fully stabilize.
19. Use the peak marker function to determine the maximum amplitude level.

#### 4.6.3 Measurement Results:

**802.11b/g mode**

Mode	Channel	Frequency Range	Test Results	Conclusion
802.11b	1	2.412GHz	Fig.85	P
		30MHz-26GHz	Fig.86	P
	6	2.437GHz	Fig.87	P
		30MHz-26GHz	Fig.88	P
	11	2.472GHz	Fig.89	P
		30MHz-26GHz	Fig.90	P
802.11g	1	2.412GHz	Fig.91	P
		30MHz-26GHz	Fig.92	P
	6	2.437GHz	Fig.93	P
		30MHz-26GHz	Fig.94	P
	11	2.472GHz	Fig.95	P

**802.11n mode**

Mode	Channel	Frequency Range	Test Results	Conclusion
802.11n(20MHz )	1	2.412GHz	Fig.96	P
		30MHz-26GHz	Fig.97	P
	6	2.437GHz	Fig.98	P
		30MHz-26GHz	Fig.99	P
	11	2.472GHz	Fig.100	P
		30MHz-26GHz	Fig.101	P
802.11n(40MHz )	1	2.412GHz	/	/
		30MHz-26GHz	/	/
	6	2.437GHz	/	/
		30MHz-26GHz	/	/
	11	2.472GHz	/	/

		30MHz-26GHz	/	/
--	--	-------------	---	---

**Conclusion: PASS**

Test figure as below:

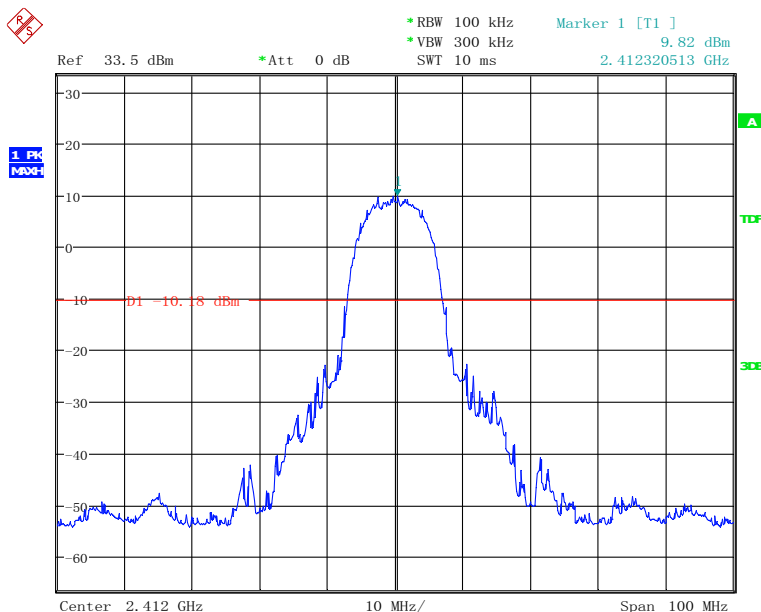

Date: 26. JAN. 2015 02:00:20

Fig.85 Conducted spurious emission: Ch1,11b,2412MHz

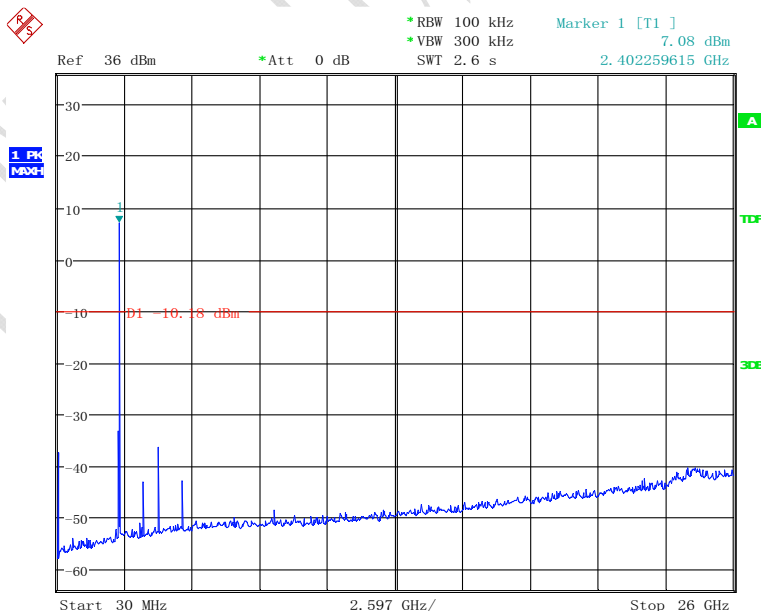

Date: 26. JAN. 2015 02:01:41

Fig.86 Conducted spurious emission: Ch1,11b,30MHz-26GHz

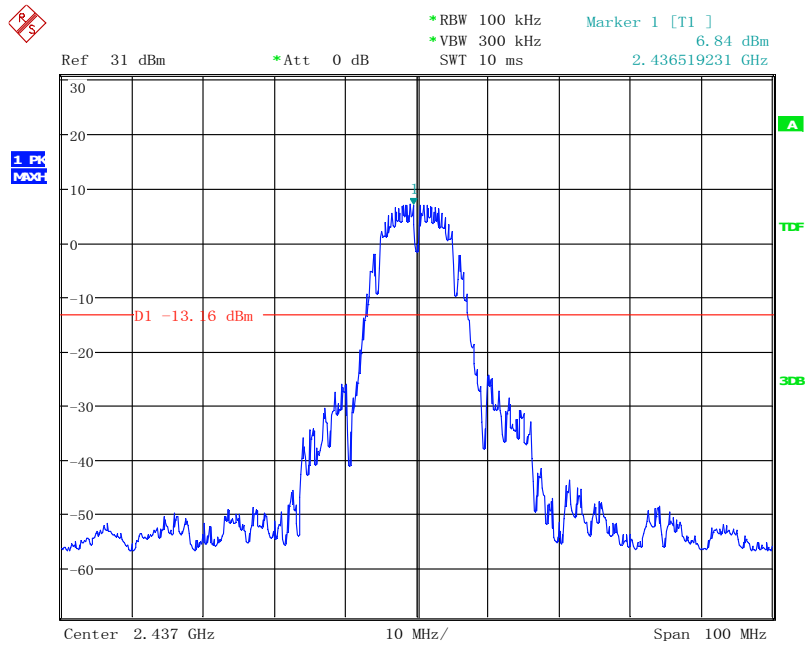

Date: 27. JAN. 2015 23:19:02

Fig.87 Conducted spurious emission: Ch6,11b,2437MHz

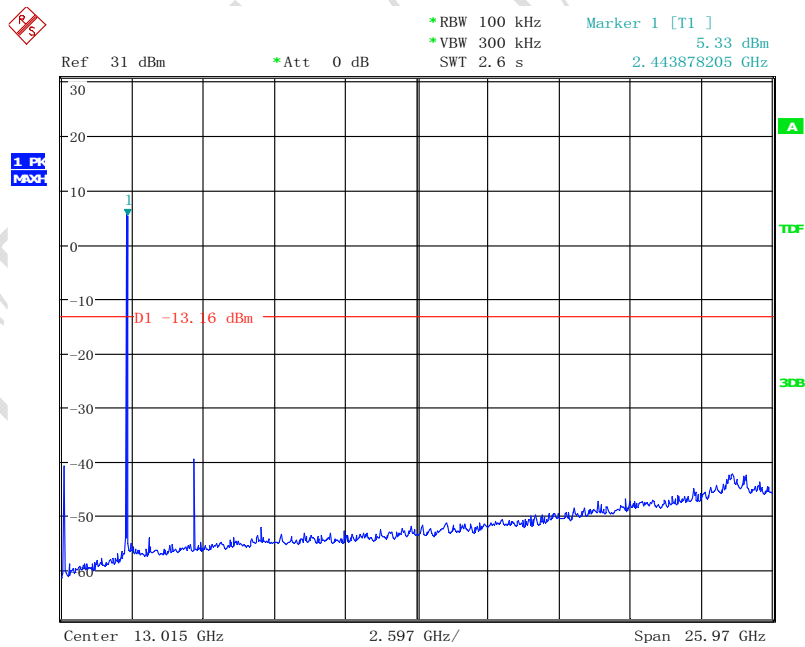

Date: 27. JAN. 2015 23:20:10

Fig.88 Conducted spurious emission: Ch6,11b,30MHz-26GHz



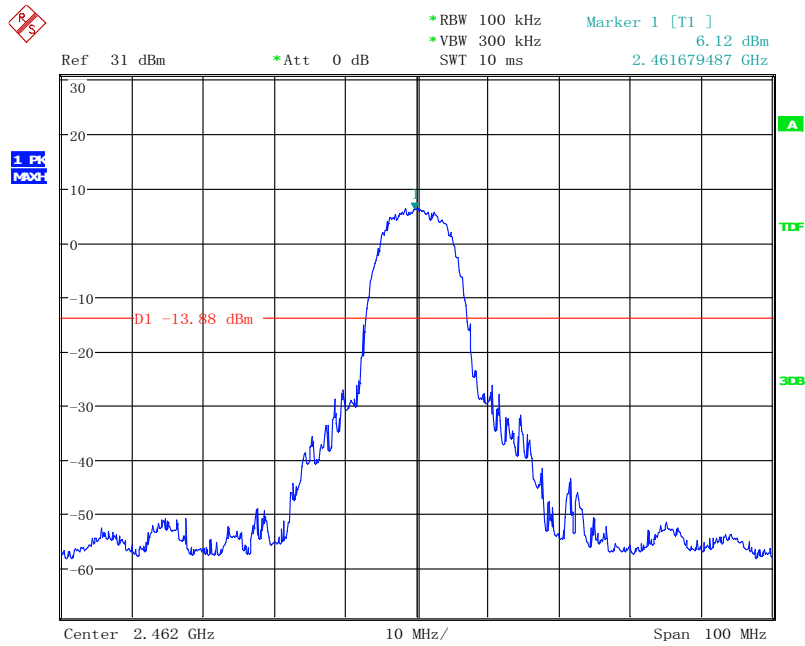

Date: 27. JAN. 2015 23:39:59

Fig.89 Conducted spurious emission: Ch11,11b,2462MHz

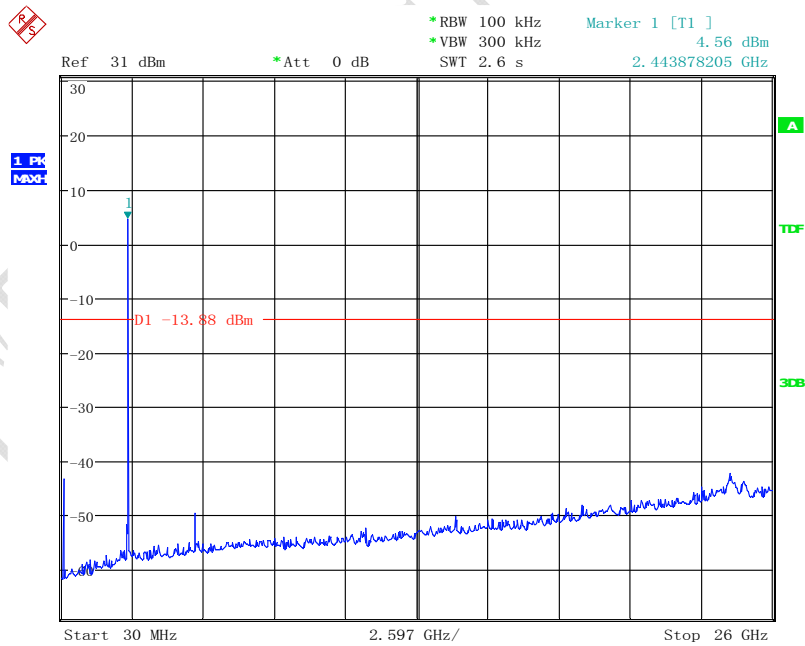

Date: 27. JAN. 2015 23:40:21

Fig.90 Conducted spurious emission: Ch11,11b,30MHz-26GHz

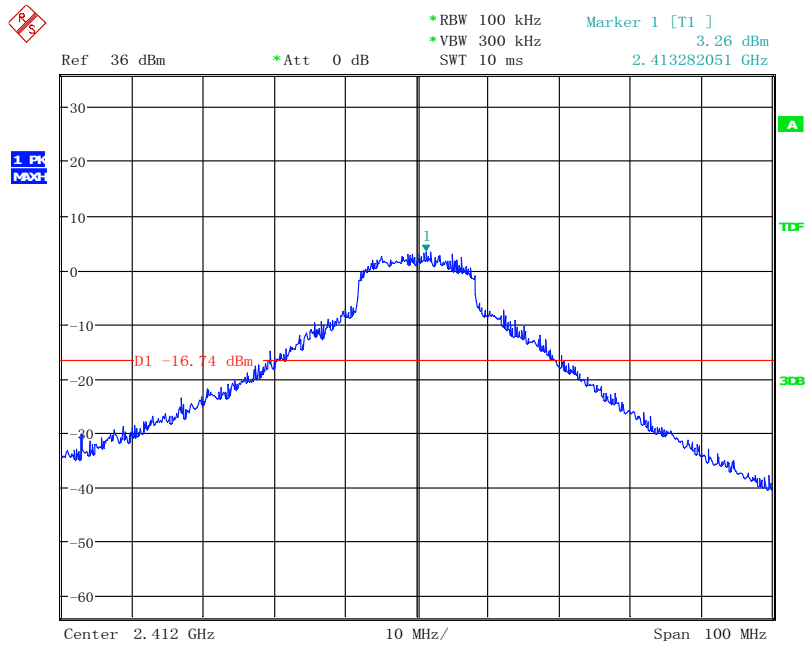

Date: 26. JAN. 2015 02:16:50

Fig.91 Conducted spurious emission: Ch1,11g,2412MHz

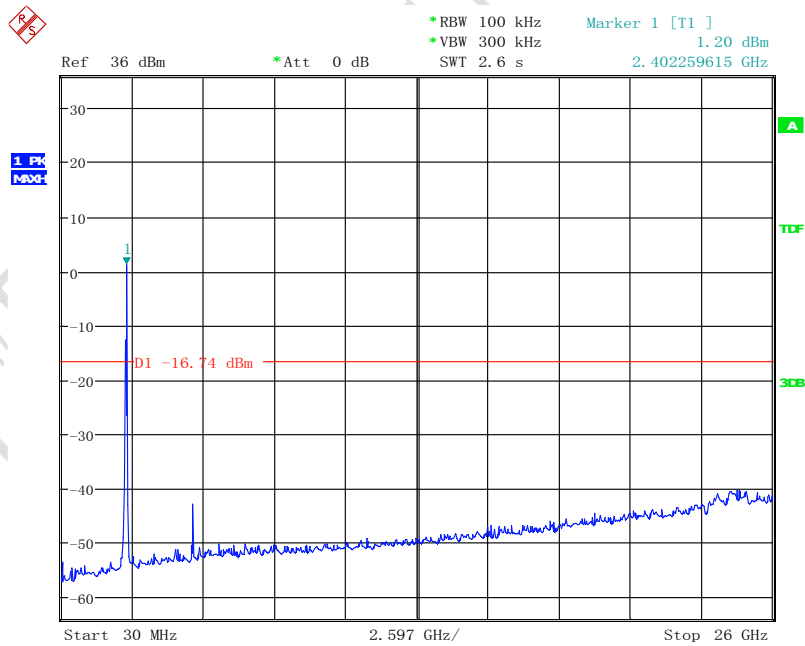

Date: 26. JAN. 2015 02:17:44

Fig.92 Conducted spurious emission: Ch1,11g,30MHz-26GHz

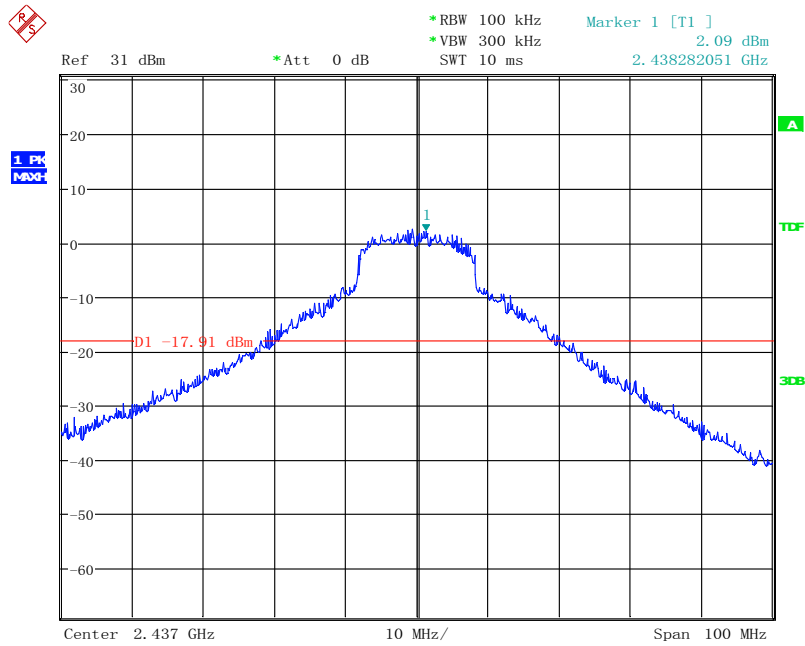

Date: 27. JAN. 2015 23:22:33

Fig.93 Conducted spurious emission: Ch6,11g,2437MHz

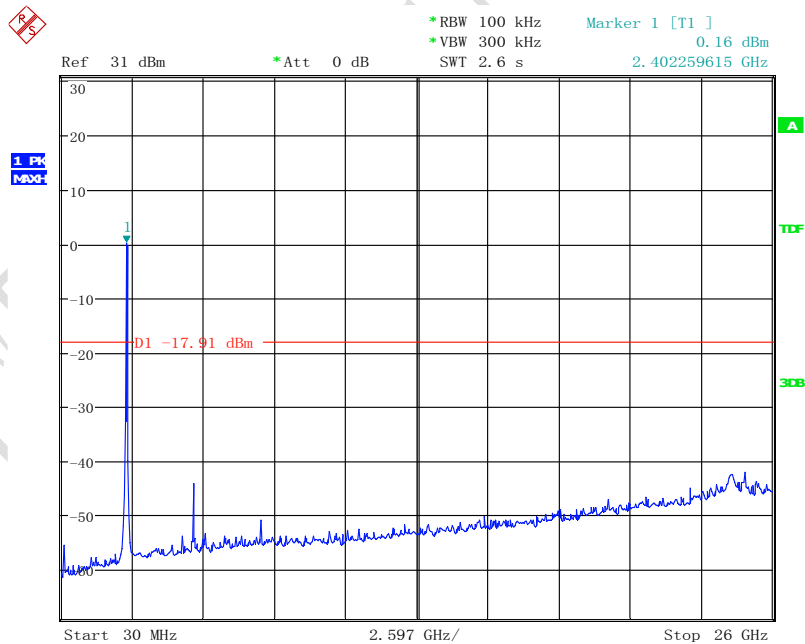

Date: 27. JAN. 2015 23:23:14

Fig.94 Conducted spurious emission: Ch6,11g,30MHz-26GHz

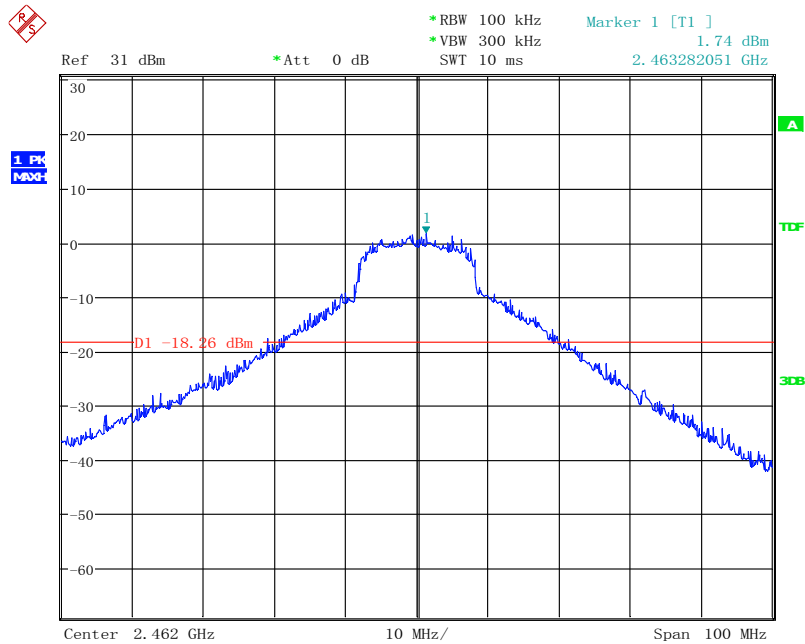

Date: 27. JAN. 2015 23:38:31

Fig.95 Conducted spurious emission: Ch11,11g,2462MHz

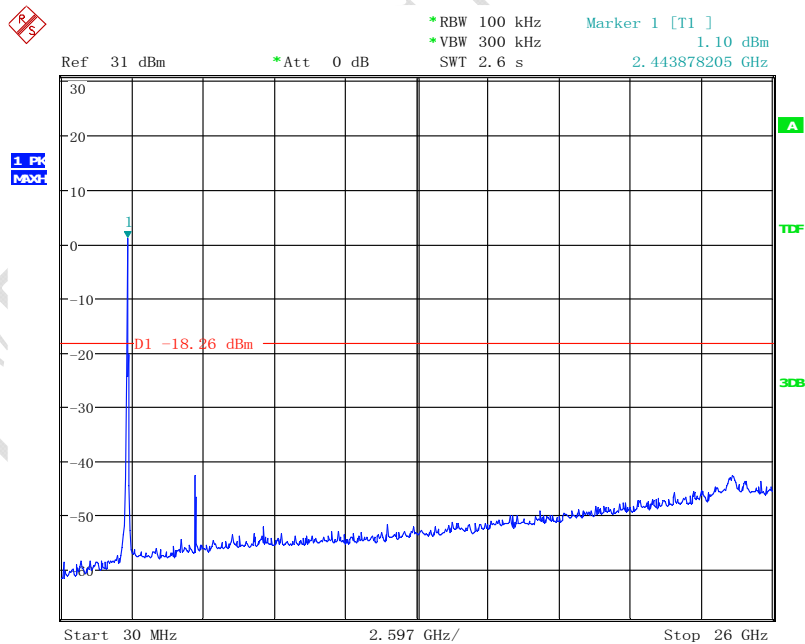

Date: 27. JAN. 2015 23:39:05

Fig.96 Conducted spurious emission: Ch11,11g,30MHz-26GHz

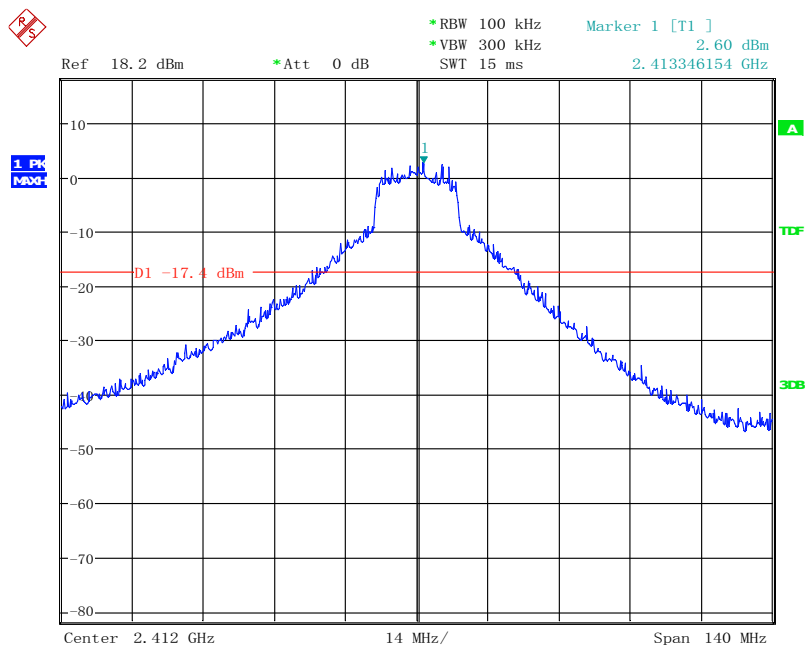

Date: 26. JAN. 2015 01:36:55

Fig.97 Conducted spurious emission: Ch1,11n(20MHz),2412MHz

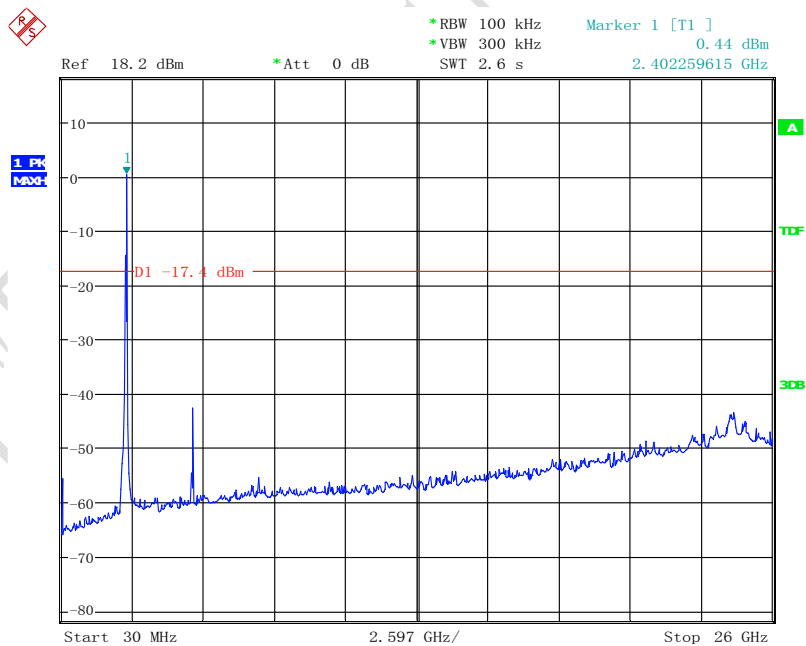

Date: 26. JAN. 2015 01:37:32

Fig.98 Conducted spurious emission: Ch1,11n(20MHz),30MHz-26GHz

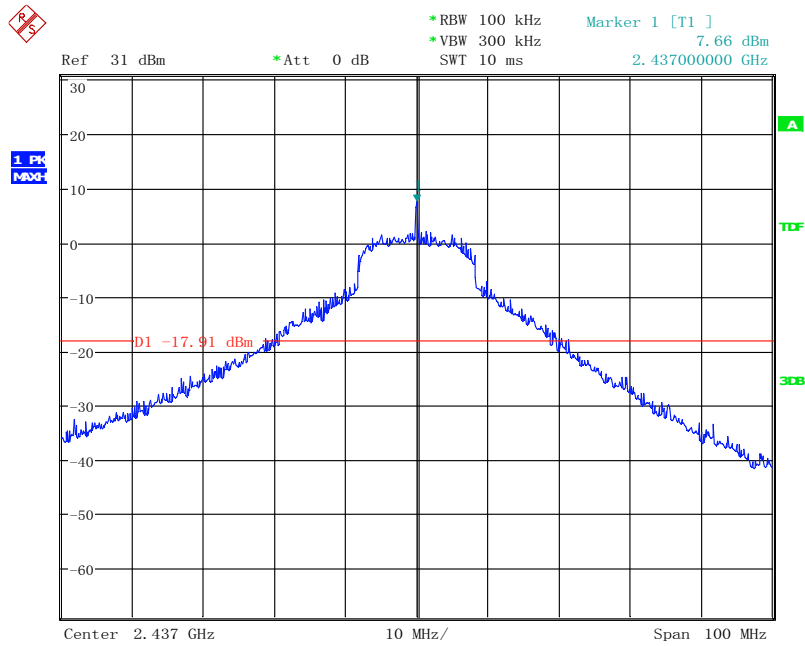

Date: 27. JAN. 2015 23:24:45

Fig.99 Conducted spurious emission: Ch6,11n(20MHz),2437MHz

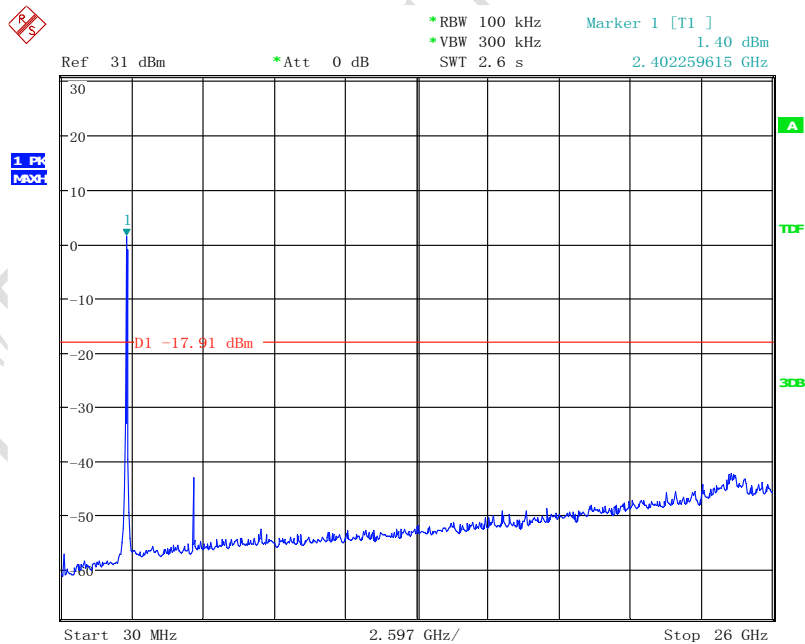

Date: 27. JAN. 2015 23:25:31

Fig.100 Conducted spurious emission: Ch6,11n(20MHz),30MHz-26GHz

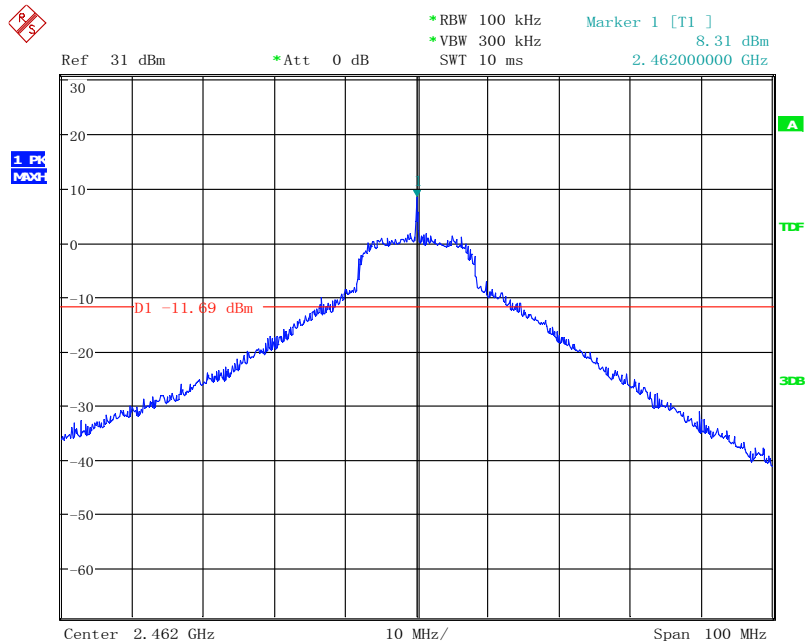

Date: 27. JAN. 2015 23:36:18

Fig.101 Conducted spurious emission: Ch11,11n(20MHz),2462MHz

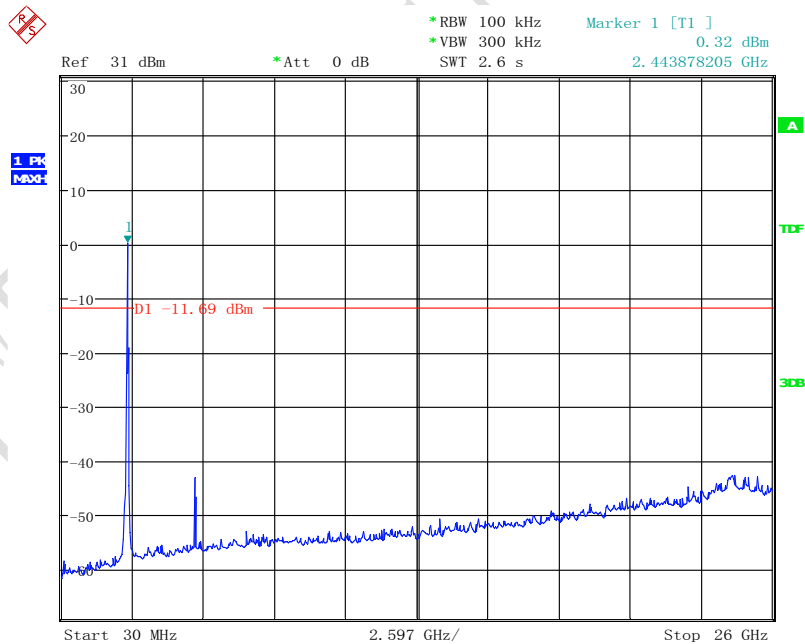

Date: 27. JAN. 2015 23:37:04

Fig.102 Conducted spurious emission: Ch11,11n(20MHz),30MHz-26GHz

### 4.7 Radiated Emission Measurement

<b>Date of Test</b>		2015-01-27				
<b>Test conditions:</b>		Ambient Temperature:15°C-35°C Relative Humidity:30%-60% Air pressure: 86-106kPa				
<b>Test Results:</b>		Pass				
<b>Test equipment Used:</b>						
Number	Description	Manufacturer	Model Number	Serial Number	Cal Due	State
1	EMI Test Receiver	R&S	ESIB26	100211	2016-01-12	Normal
2	Fully-Anechoic Chamber	ETS	11.8m×6.5m×6.3m	--	2015-11-16	Normal
3	BLUETOOTH TESTER	R/S	CBT	100657	2016-01-28	Normal
4	Loop Antenna	R&S	HFH2-Z2	836553/001	2015-08-23	Normal
5	Double-Ridged Horn Antenna	R&S	HF906	100037	2015-11-17	Normal
6	Ultra Broad Antenna	Schwarzbeck	Vulb9160	Vulb9160-3252	2015-11-24	Normal
7	Horn Antenna	ETS	3160-09	1247	2015-11-17	Normal
8	Biconical VHF-UHF test Antenna	Schwarzbeck	VUBA9117	Vulb9160-05	2015-11-24	Normal
9	Double-Ridged Horn Antenna	R/S	HF906	100036	2015-11-17	Normal
10	Signal Generator	R/S	SMR27	100003	2016-01-18	Normal

#### 4.7.1 Measurement Limit:

Standard	Limit
FCC 47 CFR Part 15.247, 15.205, 15.209	20dB below peak output power

In addition, radiated emissions which fall in the restricted bands, as defined in 15.205(a), must also comply with the radiated emission limits specified in 15.209(a) (see 15.205(c)).

#### Limit in restricted band:

Frequency of emission (MHz)	Field strength (uV/m)	Field strength (dBuV/m)
30-88	100	40
88-216	150	43.5
216-960	200	46
Above 960	500	54

#### 4.7.2 Test Method

Portable, small, lightweight, or modular devices that may be handheld, worn on the body,



or placed on a table during operation shall be positioned on a non-conducting platform, the top of which is 80 cm above the reference ground plane. The preferred area occupied by the EUT arrangement is 1 m by 1.5 m, but it may be larger or smaller to accommodate various sized EUTs. For testing purposes, ceiling- and wall-mounted devices also shall be positioned on a tabletop (see also ANSI C63.10-2009 section 6.3.4 and 6.3.5). In making any tests involving handheld, body-worn, or ceiling-mounted equipment, it is essential to recognize that the measured levels may be dependent on the orientation (attitude) of the three orthogonal axes of the EUT. Thus, exploratory tests as specified in 8.3.1 shall be carried out for various axes orientations to determine the attitude having maximum or near-maximum emission level.

The EUT was placed on a non-conductive table. The measurement antenna was placed at a distance of 3 meters from the EUT. During the tests, the antenna height and the EUT azimuth were varied in order to identify the maximum level of emissions from the EUT. This maximization process was repeated with the EUT positioned in each of its three orthogonal orientations.

Frequency of emission (MHz)	RBW/VBW	Sweep Time (s)
30-1000	100KHz/300KHz	5
1000-4000	1MHz/1MHz	15
4000-18000	1MHz/1MHz	40
18000-26500	1MHz/1MHz	20

**4.7.3 Measurement Results:**

A "reference path loss" is established and  $A_{Rpi}$  is the attenuation of "reference path loss", and including the gain of receive antenna , the gain of the preamplifier, the cable loss.

The measurement results are obtained as described below:

$$A_{Rpi} = \text{Cable loss} + \text{Antenna Gain} - \text{Preamplifier gain}$$

$$\text{Result} = P_{Mea} + A_{Rpi}$$

Channel	Frequency Range	Test Results	Conclusion
Ch1	30MH-1GHz	Fig.1	P
	1GHz-3GHz	Fig.2	P
	3GHz-18GHz	Fig.3	P

Channel	Frequency Range	Test Results	Conclusion
---------	-----------------	--------------	------------

FCC Parts 15 subpart C, ANSI C63.10-2013  
Equipment: Ilium X100

REPORT NO.: B15X50034-FCC-Wifi\_Rev1

Ch6	30MH-1GHz	Fig.4	P
	1GHz-3GHz	Fig.5	P
	3GHz-18GHz	Fig.6	P

Channel	Frequency Range	Test Results	Conclusion
Ch11	30MH-1GHz	Fig.7	P
	1GHz-3GHz	Fig.8	P
	3GHz-18GHz	Fig.9	P
All channels	18GHz-26GHz	Fig.10	P

**Ch1 30MHz-1GHz**

Frequency(MHz)	Result(dBuV/m)	ARpl (dB)	PMea(dBuV/m)	Polarity
46.008000	18.4	-24.7	43.1	V
152.802000	15.8	-29.1	44.9	V
984.665000	17.0	-13.6	30.6	H

**Ch1 1GHz-3GHz**

Frequency(MHz)	Result(dBuV/m)	ARpl (dB)	PMea(dBuV/m)	Polarity
1494.000000	44.6	-8.3	52.9	H
2011.600000	52.3	-4.3	56.6	H

**Ch1 3GHz-18GHz**

Frequency(MHz)	Result(dBuV/m)	ARpl (dB)	PMea(dBuV/m)	Polarity
4823.100000	60.0	-1.6	61.6	H
7237.225000	57.3	1.7	55.6	V

**Ch6 30MHz-1GHz**

Frequency(MHz)	Result(dBuV/m)	ARpl (dB)	PMea(dBuV/m)	Polarity
43.113000	22.7	-24.7	47.4	V
43.780000	25.8	-24.7	50.5	V
187.528000	19.6	-26.9	46.5	V

**Ch6 1GHz-3GHz**

Frequency(MHz)	Result(dBuV/m)	ARpl (dB)	PMea(dBuV/m)	Polarity
2011.600000	49.9	-4.3	54.2	H
2643.400000	46.3	1.7	44.6	H

**Ch6 3GHz-18GHz**

Frequency(MHz)	Result(dBuV/m)	ARpl (dB)	PMea(dBuV/m)	Polarity
4873.000000	62.0	-1.4	63.4	H
7315.275000	59.7	1.6	58.1	V
9747.900000	52.9	4.4	48.5	H

**Ch11 30MHz-1GHz**

Frequency(MHz)	Result(dBuV/m)	ARpl (dB)	PMea(dBuV/m)	Polarity
47.054000	19.3	-24.8	44.1	V
187.528000	15.4	-26.9	42.3	H
977.884000	17.0	-13.7	40.7	V

**Ch11 1GHz-3GHz**

Frequency(MHz)	Result(dBuV/m)	ARpl (dB)	PMea(dBuV/m)	Polarity
1494.600000	48.2	-8.3	56.5	V

**Ch11 3GHz-18GHz**

Frequency(MHz)	Result(dBuV/m)	ARpl (dB)	PMea(dBuV/m)	Polarity
----------------	----------------	-----------	--------------	----------

FCC Parts 15 subpart C, ANSI C63.10-2013  
Equipment: Ilium X100

REPORT NO.: B15X50034-FCC-Wifi\_Rev1

4924.400000	59.9	-1.0	60.9	V
7386.450000	61.9	1.7	60.2	V
9842.100000	58.6	4.7	53.9	V

**All Ch 18GHz-26.5GHz**

Frequency(MHz)	Result(dBuV/m)	ARpl (dB)	PMea(dBuV/m)	Polarity
19525.786000	49.0	6.97	42.03	V
20684.980000	47.7	6.97	40.73	H
22119.789000	45.3	3.05	42.05	V
23627.899000	43.8	3.05	40.75	H
24606.319000	43.4	3.05	40.35	V
25244.558000	43.6	3.05	40.55	H

**Note: all the test data shown was peak detected.**

**Conclusion: PASS**

**Test graphs as below:**

RE 30MHz-1GHz H

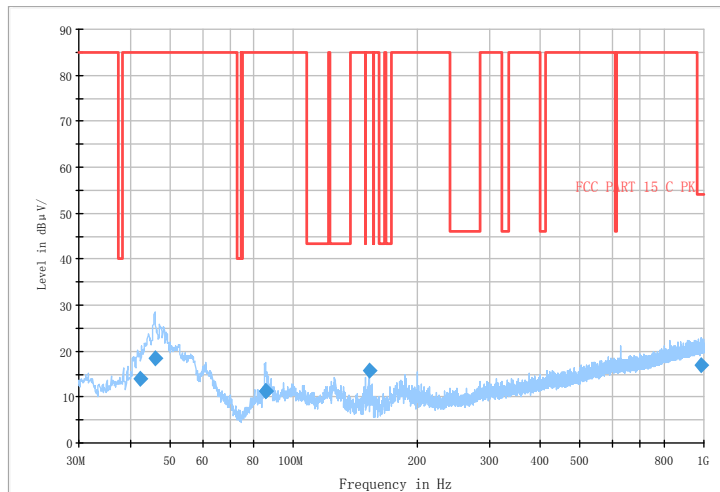

Fig.1 Radiated emission: Ch1, 30MHz-1GHz

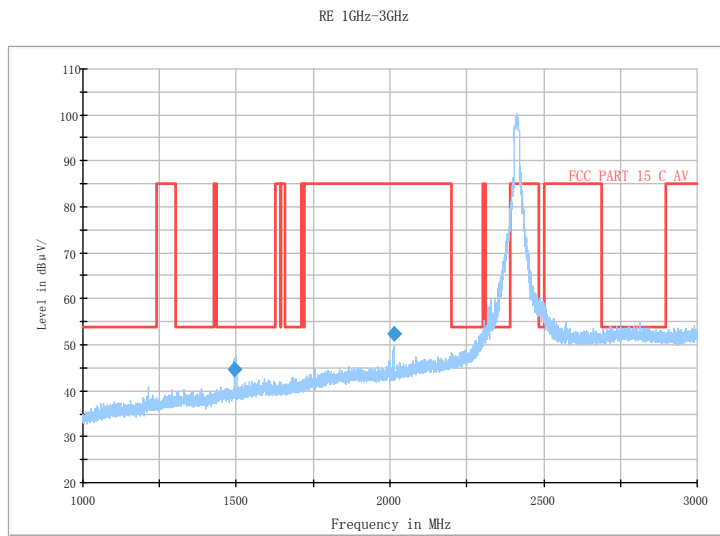

Fig.2 Radiated emission: Ch1, 1GHz-3GHz

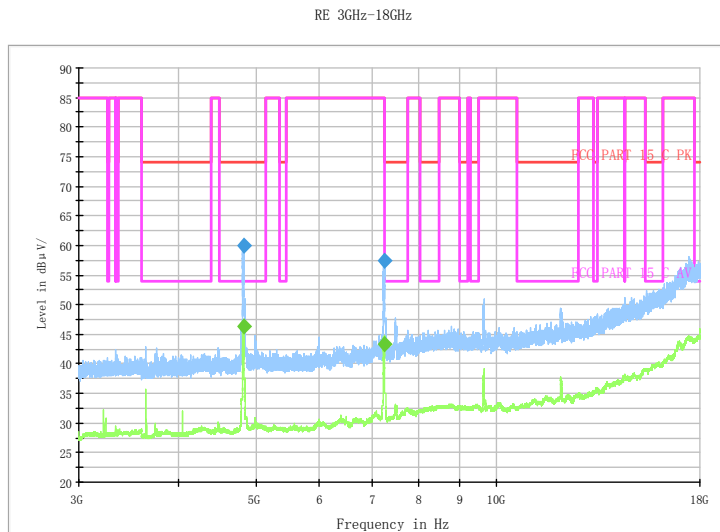

Fig.3 Radiated emission: Ch1, 3GHz-18GHz

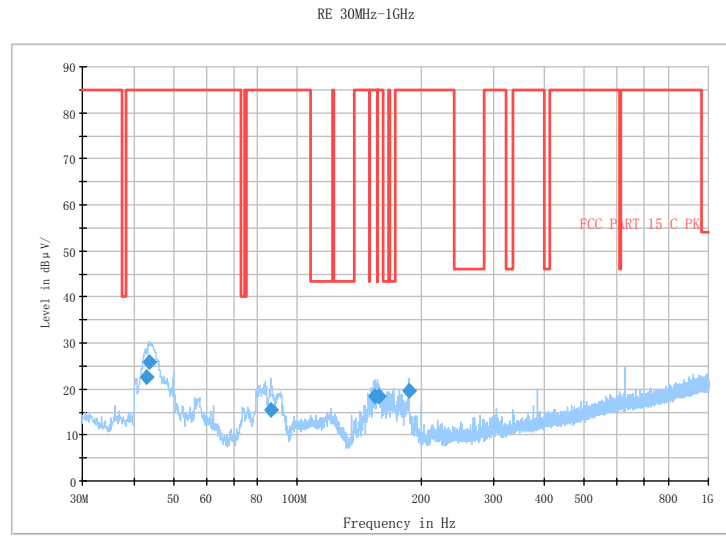

Fig.4 Ch6, 30MHz-1GHz

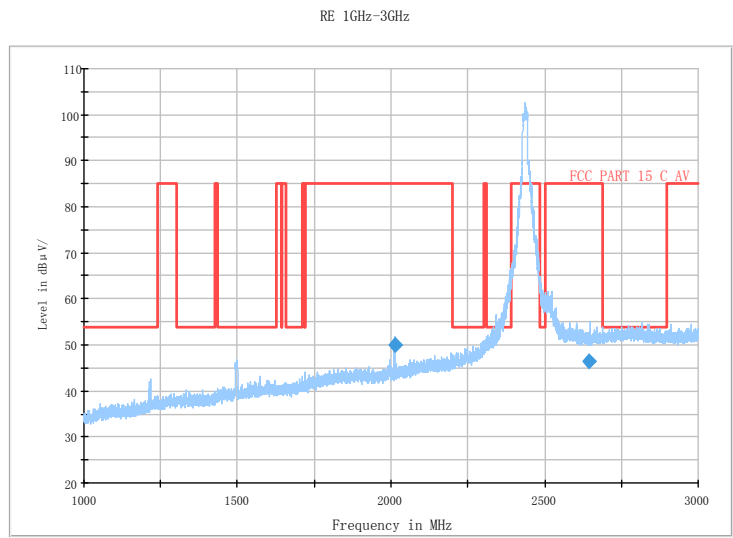

Fig.5 Radiated emission: Ch6, 1GHz-3GHz

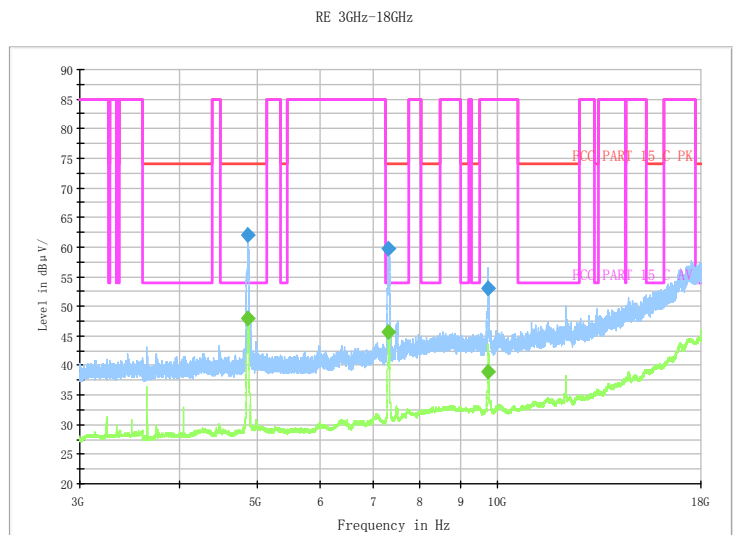

Fig.6 Radiated emission: Ch6, 3GHz-18GHz

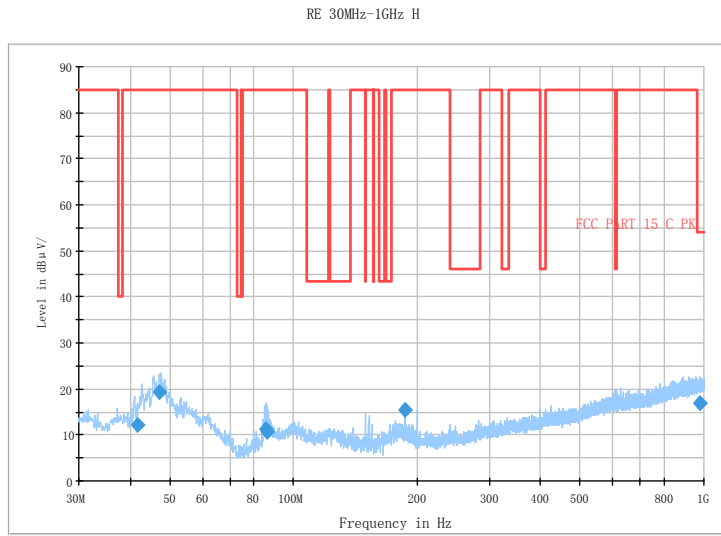

Fig.7 Radiated emission: Ch11, 30MHz-1GHz

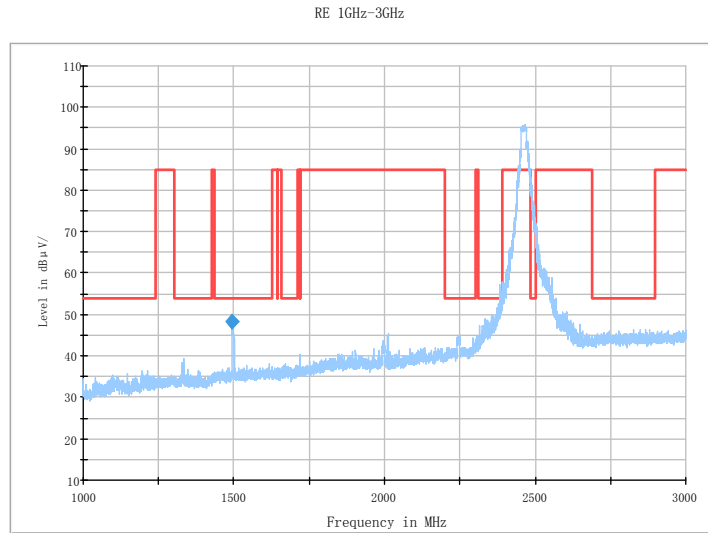

Fig.8 Radiated emission: Ch11, 1GHz-3GHz



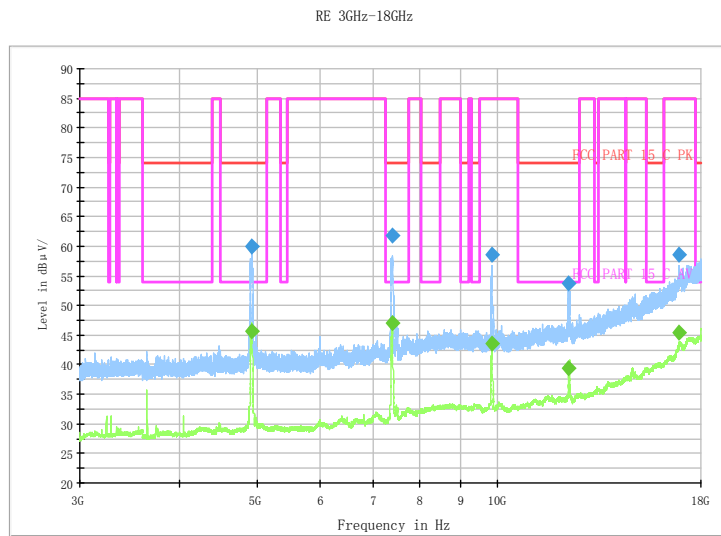

Fig.9 Radiated emission: Ch11, 3GHz-18GHz

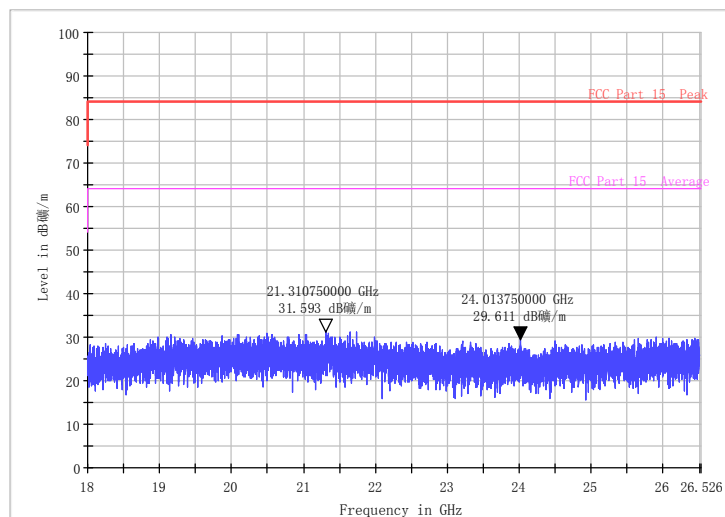

Fig.10 Radiated emission: 18 GHz - 26 GHz

**Test photo**

See the Pic1- Pic 3 in document "Ilium X100\_Wifi\_BT Test Setup Photos\_Rev1".

### 4.8 Power line Conducted Emissions

<b>Specifications:</b>	ANSI C63.4 voltage mains test					
<b>Date of Test</b>	2015-01-28					
<b>Test conditions:</b>	Ambient Temperature:15°C-35°C Relative Humidity:30%-60% Air pressure: 86-106kPa					
<b>Operation Mode</b>	Normal					
<b>Test Results:</b>	Pass					
<b>Test equipment Used:</b>						
Asset Number	Description	Manufacturer	Model Number	Serial Number	Cal Due	State
7805	EMI Test Receiver	R/S	ESIB26	100211	2016-01-12	Normal
7330	Artificial Mains Network	R/S	ESH2-Z5	837480/002	2016-01-08	Normal
714	Shielding Room	ETS	--	19003	2015-11-16	Normal
7330	BLUETOOTH TESTER	R/S	CBT	100657	2016-01-28	Normal

#### LIMIT

For an intentional radiator which is designed to be connected to the public utility (AC) power line, the radio frequency voltage that is conducted back onto the AC power line on any frequency or frequencies within the band 150 kHz to 30 MHz shall not exceed 250 microvolt (The limit decreases linearly with the logarithm of the frequency in the range 0.15 MHz to 0.50 MHz). The limits at specific frequency range are listed as follows:

#### Limits of the conducted disturbance at the AC mains ports:

Frequency range	Limit(Quasi-peak)	Limit(Average)
0.15 MHz to 0.5 MHz	66 dBµV – 56 dBµV	56 dBµV – 46 dBµV
>0.5 MHz to 5MHz	56 dBµV	46 dBµV
>5 MHz to 30 MHz	60 dBµV	50 dBµV

NOTE: The limit decreases linearly with the logarithm of the frequency in the range 0.15 MHz to 0.50 MHz.

Compliance with this provision shall be based on the measurement of the radio frequency voltage between each power line (LINE and NEUTRAL) and ground at the power terminals.

#### Test Setup

The EUT was placed in a shielding room. The BLUETOOTH TESTER was used to set the TX channel and power level. The ac adapter output is connected to Receiver through an AMN (Artificial Mains Network).

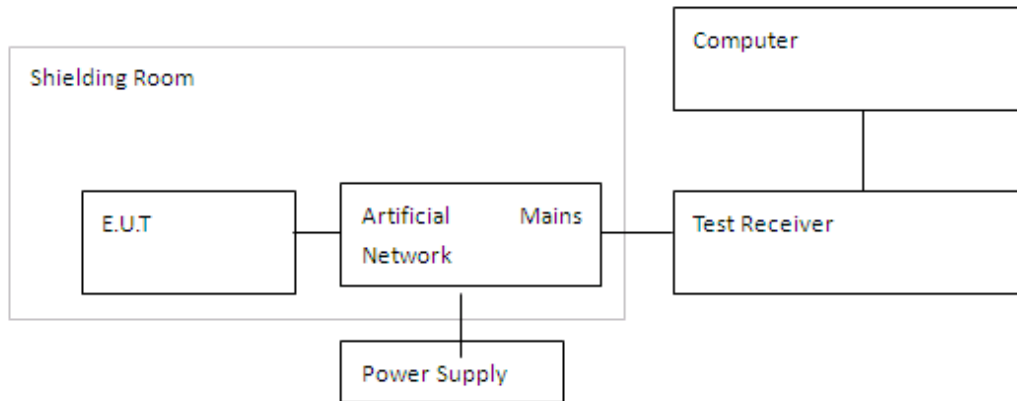

**TEST PROCEDURE**

1. The EUT is placed on a wooden table 80 cm above the reference ground plane.
2. The EUT is connected via LISN to a test power supply.
3. The measurement results are obtained as described below:
4. Detectors – Quasi Peak and Average Detector.

**The measurement is made according to Public notice FCC Public Notice DA 00-705, March 2000, and ANSI C63.4-2014.**

Test Result:

Line L&N					
Detector (QP)	Frequency (MHz)	Level (dBµV)	Limit (dBµV)	Line	PE
QP	2.154844	53.7	56.0	L1	FLO
QP	2.491494	48.3	56.0	L1	FLO
QP	4.174912	36.8	56.0	L1	FLO
QP	8.024312	43.5	60.0	L1	FLO
QP	8.282962	55.4	60.0	L1	FLO
QP	8.284125	56.0	60.0	L1	FLO

Line L&N					
Detector (AV)	Frequency (MHz)	Level (dBµV)	Limit (dBµV)	Line	PE
AV	2.154844	40.7	46.0	L1	FLO
AV	2.425494	40.3	46.0	L1	FLO
AV	4.175181	25.9	46.0	L1	FLO
AV	8.016312	43.5	50.0	L1	FLO
AV	8.284962	46.1	50.0	L1	FLO
AV	8.286125	46.0	50.0	L1	FLO

CISPR N&L1 Voltage 150k to 30MHz-Class B

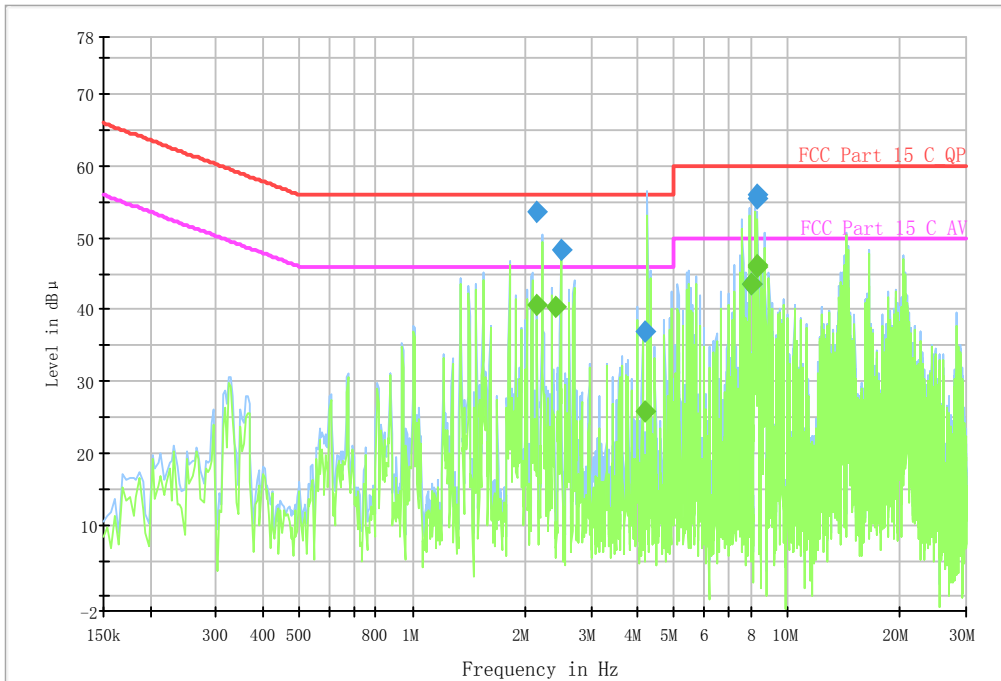

Line L & Line N

**Test photo**

See the Pic4 in document "Ilium X100\_Wifi\_BT Test Setup Photos\_Rev1".

## **Annex A External Photos**

See the document "Ilium X100- External Photos".

## **Annex B Internal Photos**

See the document "Ilium X100-Internal Photos".

## **ANNEX C Deviations from Prescribed Test Methods**

No deviation from Prescribed Test Methods.

\_\_\_\_\_ The End of this Report \_\_\_\_\_