



# TEST REPORT

REPORT NUMBER: B16X50179-BT\_Rev1

ON

**Type of Equipment:** Mobile Phone  
**Model Name:** U200  
**Manufacturer:** Corporativo Lanix S.A.de C.V.

## ACCORDING TO

FCC Part 15, Subpart C, 2015:

15.205 Restricted bands of operation, 15.209 Radiated emission limits; general requirements,  
15.247 Operation within the bands 902–928 MHz, 2400–2483.5 MHz, and 5725–5850 MHz

ANSI C63.4-2014, Methods of Measurement of Radio-Noise Emissions from Low-Voltage Electrical and Electronic Equipment in the Range of 9 kHz to 40 GHz

ANSI C63.10-2013: American National Standard of Procedures for Compliance Testing of Unlicensed Wireless Devices

FCC Public Notice DA 00-705, March-2000, Filing and Measurement Guidelines for Frequency Hopping Spread Spectrum Systems

**China Telecommunication Technology Labs.**

*Month date, year*

June, 17, 2016

Signature



**He Guili**

**Director**

**Note:**

The test results in this test report relate only to the devices specified in this report. This report shall not be reproduced except in full without the written approval of China Telecommunication Technology Labs.

**FCC ID:** ZC4U200

**Report Date:** 2016-06-17

**Test Firm Name:** China Telecommunication Technology Labs

**FCC Registration Number:** 840587

#### Statement

The measurements shown in this report were made in accordance with the procedures described on test pages. All reported tests were carried out on a sample equipment to demonstrate limited compliance with FCC Parts 15, subpart C. The sample tested was found to comply with the requirements defined in the applied rules.

## CONTENTS

<b>1 GENERAL INFORMATION</b> .....	<b>4</b>
<b>1.1 NOTES</b> .....	<b>4</b>
<b>1.2 TESTERS</b> .....	<b>5</b>
<b>1.3 TESTING LABORATORY INFORMATION</b> .....	<b>6</b>
<b>1.4 DETAILS OF APPLICANT OR MANUFACTURER</b> .....	<b>7</b>
<b>2 TEST ITEM</b> .....	<b>8</b>
<b>2.1 GENERAL INFORMATION</b> .....	<b>8</b>
<b>2.2 OUTLINE OF EQUIPMENT UNDER TEST</b> .....	<b>8</b>
<b>2.3 MODIFICATIONS INCORPORATED IN EUT</b> .....	<b>8</b>
<b>2.4 EQUIPMENT CONFIGURATION</b> .....	<b>8</b>
<b>2.5 OTHER INFORMATION</b> .....	<b>8</b>
<b>3 SUMMARY OF TEST RESULTS</b> .....	<b>9</b>
<b>4 TEST EQUIPMENTS AND ANCILLARIES USED FOR TESTS</b> .....	<b>10</b>
<b>5 TEST RESULTS</b> .....	<b>11</b>
<b>5.1 PEAK POWER</b> .....	<b>11</b>
<b>5.2 BAND EDGES</b> .....	<b>17</b>
<b>5.3 FREQUENCY SEPARATION</b> .....	<b>30</b>
<b>5.4 NUMBER OF HOPPING FREQUENCY</b> .....	<b>38</b>
<b>5.5 TIME OF OCCUPANCY</b> .....	<b>42</b>
<b>5.6 SPURIOUS MEASUREMENT (CONDUCTED)</b> .....	<b>49</b>
<b>5.8 RATIO RADIATED EMISSION MEASUREMENT</b> .....	<b>75</b>
<b>5.8 POWER LINE CONDUCTED EMISSIONS</b> .....	<b>83</b>
<b>ANNEX A EUT PHOTOS</b> .....	<b>86</b>
<b>ANNEX B DEVIATIONS FROM PRESCRIBED TEST METHODS</b> .....	<b>87</b>

## 1 General Information

### 1.1 Notes

All reported tests were carried out on a sample equipment to demonstrate limited compliance with FCC Parts 15, subpart C and ANSI C63.4-2014 and FCC DA 00-705.

The test results of this test report relate exclusively to the item(s) tested as specified in section 2.

The following deviation from, additions to, or exclusions from the test specifications have been made. See Annex C.

China Telecommunication Technology Labs authorizes the applicant or manufacturer (see section 1.4) to reproduce this report provided, and the test report may only be reproduced or published in full. Reproduction or publication of extracts from the report requires the prior written approval of China Telecommunication Technology Labs. Mr. He Guili.

Any use which a third party makes of this report, or any reliance on or decisions to be made based on it, are the responsibility of such third parties. China Telecommunication Technology Labs accepts no responsibility for damages, if any, suffered by any third party as a result of decisions made or actions based on this report.

## 1.2 Testers

Name: Li Guoqing  
Position: Engineer  
Department: Department of RF test  
Date: 2016-05-24 to 2016-05-30

Signature: 

Editor of this test report:

Name: Li Guoqing  
Position: Engineer  
Department: Department of RF test  
Date: 2016-06-17

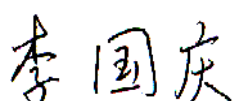
Signature: 

Technical responsibility for area of testing:

Name: Zou Dongyi  
Position: Manager  
Department: Director of the laboratory  
Date: 2016-06-17

Signature: 

### 1.3 Testing Laboratory information

#### 1.3.1 Location

Name: China Telecommunication Technology Labs.  
Address: No. 11, Yue Tan Nan Jie, Xi Cheng District  
BEIJING  
P. R. CHINA, 100083  
Tel: +86 10 68094053  
Fax: +86 10 68011404  
Email: emc@chinattl.com

#### 1.3.2 Details of accreditation status

Accredited by: China National Accreditation Service for Conformity  
Assessment (CNAS)  
Registration number: CNAS Registration No. CNAS L0570  
Standard: ISO/IEC 17025:2005

#### 1.3.3 Test location, where different from section 1.3.1

Name: -----  
Street: -----  
City: -----  
Country: -----  
Telephone: -----  
Fax: -----  
Postcode: -----

#### 1.4 Details of applicant or manufacturer

##### 1.4.1 Applicant

Name: Corporativo Lanix S.A.de C.V.  
Address: Carretera Internacional Hermosillo - Nogales Km 8.5  
Hermosillo, Sonora, México  
Country: México  
Telephone: 0052 16621090811  
Fax: --  
Contact: Oscar Guzman  
Email: oguzman@lanix.com

##### 1.4.2 Manufacturer (if different from applicant in section 1.4.1)

Name: Corporativo Lanix S.A.de C.V.  
Address: Carretera Internacional Hermosillo - Nogales Km 8.5  
Hermosillo, Sonora, México  
Country: México  
Telephone: 0052 16621090811  
Fax: --  
Contact: Oscar Guzman  
Email: oguzman@lanix.com

## 2 Test Item

### 2.1 General Information

Manufacturer: Corporativo Lanix S.A.de C.V.  
 Type of Equipment: Mobile Phone  
 Model Name: U200  
 Serial Number: S1/7: 356307070001879  
 S3/7: 356307070001895  
 Production Status: Product  
 Receipt date of test item: 2016-05-24

### 2.2 Outline of Equipment under Test

The U200, referred to as “EUT” hereafter, is a multi-band wireless modem operating on the GSM networks. The table below shows the supported bands for the EUT.

Technology	Band	UL Freq.(MHz)	DL Freq.(MHz)	Note
GSM	GSM850	824 - 849	869 – 894	--
	PCS1900	1850 - 1910	1930 - 1990	--

### 2.3 Modifications Incorporated in EUT

The EUT has not been modified from what is described by the brand name and unique type identification stated above.

### 2.4 Equipment Configuration

Equipment configuration list:

Item	Generic Description	Manufacturer	Type	Serial No.	Remarks
A	Modem	Corporativo Lanix S.A.de C.V.	U200	S1/7: 356307070001879 S3/7: 356307070001895	None
B	Adaptor	None	None	--	None

### 2.5 Other Information

--



### 3 Summary of Test Results

A brief summary of the tests carried out is shown as following.

FCC Rules	Name of Test	Result
15.247 (b)(3)(i),(ii)and(iii)	Peak power	Pass
15.247 (d)	Band edge (conducted)	Pass
15.247(a)(1)	Frequency separation	Pass
15.247(a)(1)(ii)	Number of hopping frequency	Pass
15.247(a)(1)(iii)	Time of occupancy	Pass
15.209(a) and 15.205(a)	Spurious emission (conducted)	Pass
15.209(a) and 15.205(a)	Spurious emission (radiated)	Pass
ANSI C63.4 voltage mains test	Power line Conducted Emissions	Pass

#### 4 Test Equipments and Ancillaries Used For Tests

The test equipments and ancillaries used are as follows.

No.	Equipment	Model	SN	Manufacture	Cal. Due Date
1	EMI Test Receiver	ESU26	100367	R&S	2017-03-04
2	Trilog super broadband test antenna	VULB 9163	9163-544	R&S	2017-01-05
3	Double-Ridged Horn Antenna	HF907	100356	R&S	2016-12-12
4	Fully-Anechoic Chamber	11.8m×6.5m×6.3m	--	ETS	2017-08-19
5	Universal Radio Communication Tester	CMW500	128181	R&S	2017-03-04
6	Signal Generator	SMU200A	104517	R&S	2017-03-04
7	spectrum analyzer	FSQ 26	201137/026	R&S	2017-03-04
8	Climate chamber	SH-241	92010759	ESPEC	2017-03-04
9	DC Power Supply	N6705B	MY50000919	Agilent	2017-12-06

## 5 Test Results

### 5.1 Peak power

<b>Specifications:</b>	FCC Part 15.247 (b)(3)(i),(ii)and(iii)
<b>DUT Serial Number:</b>	S3/7: 356307070001895
<b>Test conditions:</b>	Ambient Temperature:15°C -35°C Relative Humidity:30%-60% Air pressure: 86-106kPa
<b>Test Results:</b>	Pass

#### Limit Level Construction:

The maximum peak output power of the intentional radiator shall not exceed the following:

1. For systems using digital modulation in the bands of 902 - 928 MHz, 2400 - 2483.5 MHz, and 5725 - 5850 MHz: 1 watt.
2. Except as shown in paragraphs (b)(3) (i), (ii) and (iii) of this section, if transmitting antennas of directional gain greater than 6 dBi are used the peak output power from the intentional radiator shall be reduced below the stated values in paragraphs (b)(1) or (b)(2) of this section, as appropriate, by the amount in dB that the directional gain of the antenna exceeds 6 dBi.

#### Test Setup:

The BLUETOOTH TESTER was used to set the TX channel and power level. The transmitter output is connected to Spectrum analyzer through a coupler.

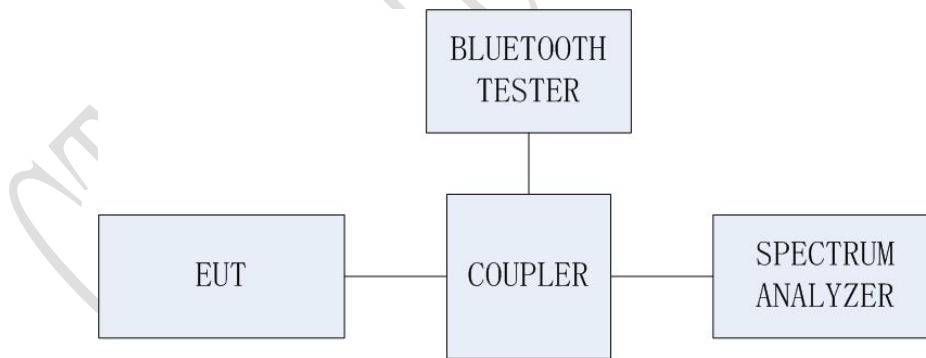

#### Test Method:

The transmitter output is connected to the Spectrum Analyzer. The Spectrum Analyzer is set to the peak detector mode. The RBW is set to 3MHz. The VBW is set to 3MHz.

The measurement is made according to Public notice FCC Public Notice DA 00-705, March 2000, and ANSI C63.10-2013.

**Note:** --

**GFSK Mode:**

Channel No.	Frequency (MHz)	Output Power (dBm)	Limit (dBm)	Result
Low: 0	2401.717	8.06	30	Pass
Middle: 39	2440.728	8.12		Pass
High: 78	2479.760	7.30		Pass

**Pi/4 DQPSK Mode:**

Channel No.	Frequency (MHz)	Output Power (dBm)	Limit (dBm)	Result
Low: 0	2401.728	6.59	30	Pass
Middle: 39	2441.064	6.72		Pass
High: 78	2480.064	5.95		Pass

**8DPSK Mode:**

Channel No.	Frequency (MHz)	Output Power (dBm)	Limit (dBm)	Result
Low: 0	2401.904	7.12	30	Pass
Middle: 39	2441.048	7.41		Pass
High: 78	2480.016	6.53		Pass

**Graphical results :**

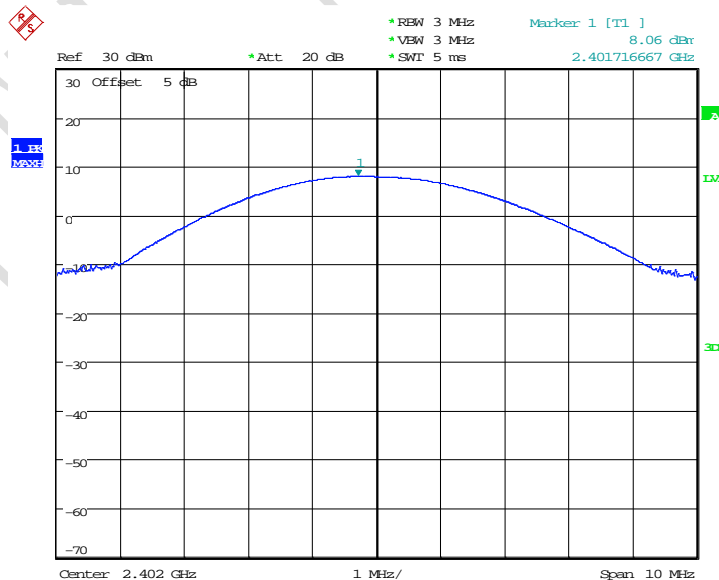

Date: 26.MAY.2016 10:13:17

GFSK Channel 0

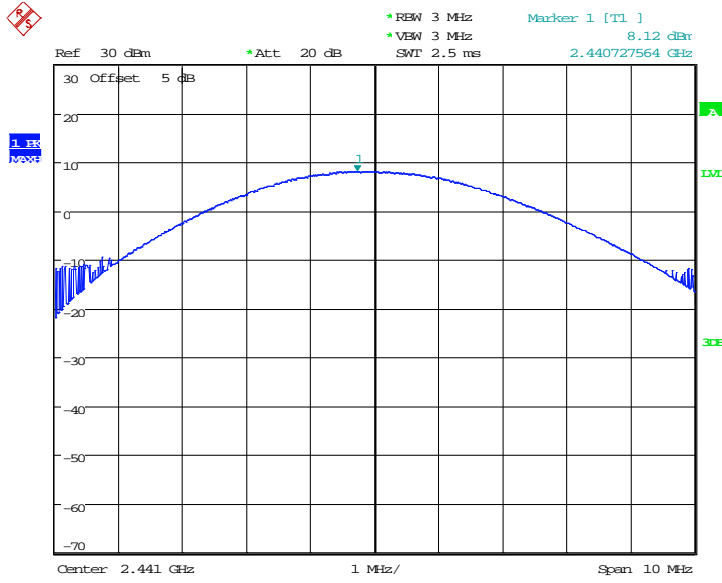

Date: 26.MAY.2016 10:26:24

### GFSK Channel 39

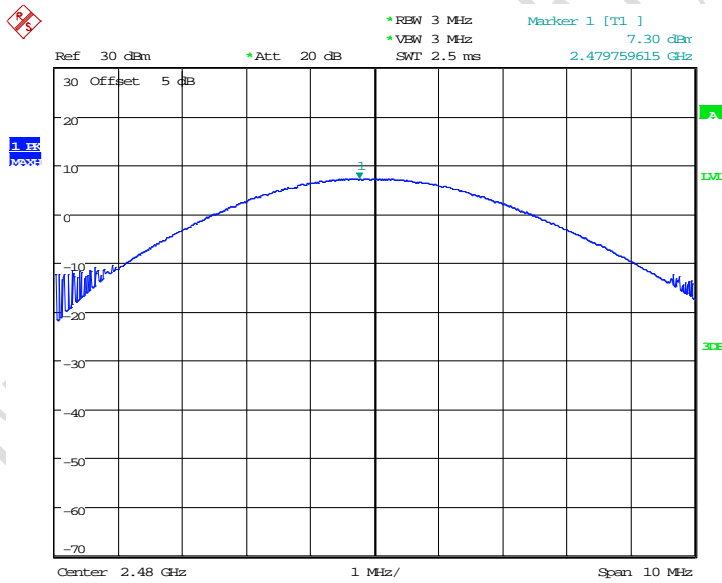

Date: 26.MAY.2016 10:27:34

### GFSK Channel 78

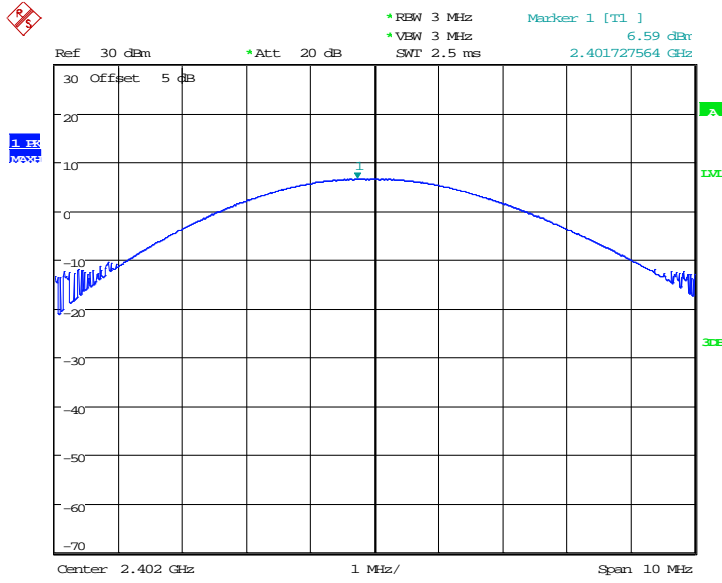

Date: 26.MAY.2016 10:31:03

### Pi/4 DQPSK Channel 0

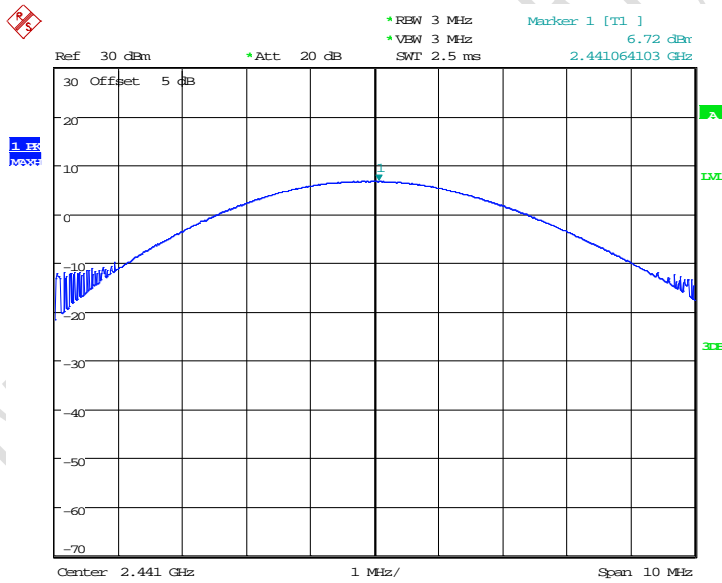

Date: 26.MAY.2016 10:31:40

### Pi/4 DQPSK Channel 39

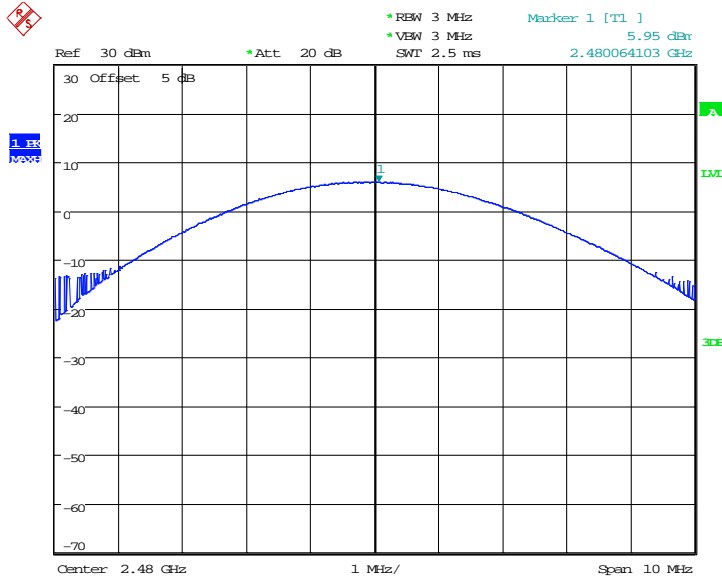

Date: 26.MAY.2016 10:32:14

### Pi/4 DQPSK Channel 78

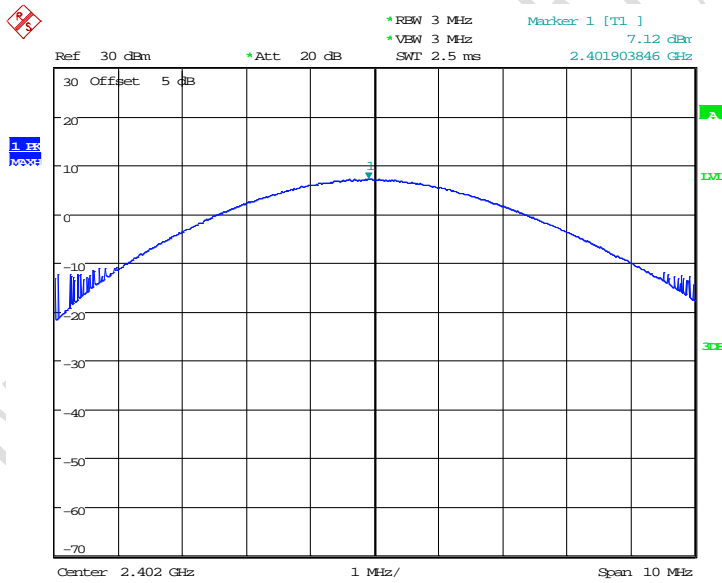

Date: 26.MAY.2016 10:33:26

### 8DPSK Channel 0

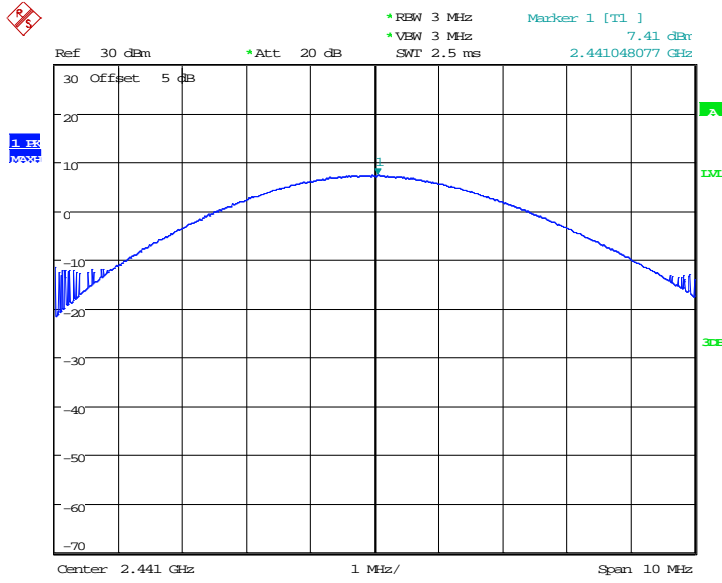

Date: 26.MAY.2016 10:34:18

### 8DPSK Channel 39

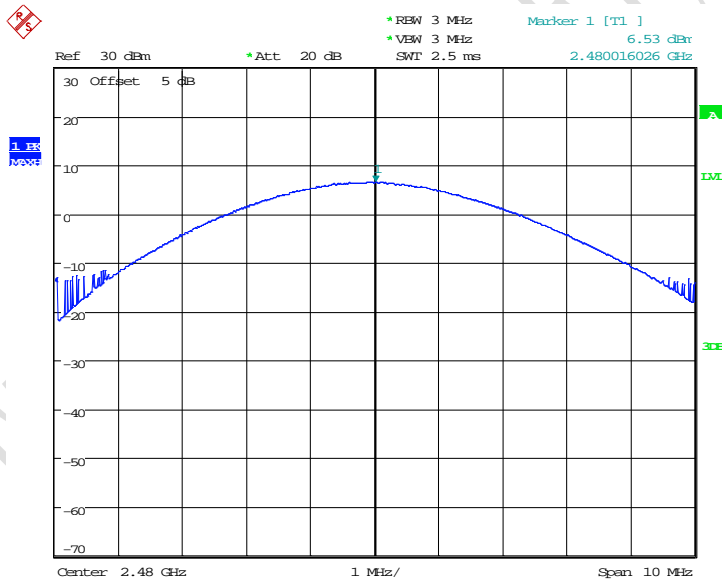

Date: 26.MAY.2016 10:34:45

### 8DPSK Channel 78



**5.2 Band edges**

<b>Specifications:</b>	FCC Part 15.247 (d)
<b>DUT Serial Number:</b>	S1/7: 356307070001879 S3/7: 356307070001895
<b>Test conditions:</b>	Ambient Temperature:15°C-35°C Relative Humidity:30%-60% Air pressure: 86-106kPa
<b>Test Results:</b>	--

**Limit Level Construction:**

According to §15.247(d), in any 100 kHz bandwidth outside the frequency band in which the spread spectrum or digitally modulated intentional radiator is operating, the radio frequency power that is produced by the intentional radiator shall be at least 20 dB below that in the 100 kHz bandwidth within the band that contains the highest level of the desired power, based on either an RF conducted or a radiated measurement, provided the transmitter demonstrates compliance with the peak conducted power limits.

**Test Setup:**

The BLUETOOTH TESTER was used to set the TX channel and power level. The transmitter output is connected to Spectrum analyzer through a coupling.

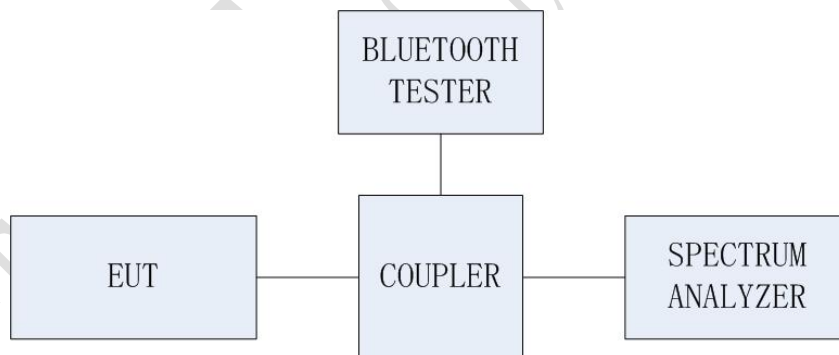

**Test procedure:**

The transmitter output is connected to the Spectrum Analyzer. The Spectrum Analyzer is set to the peak detector mode. The spectrum analyzer is set to:

1. Span = 10 MHz
2. RBW = 100 KHz
3. VBW = 300 KHz
4. Sweep = auto

The measurement is made according to Public notice FCC Public Notice DA 00-705, March 2000, and ANSI C63.4-2003.

**Note: --**

**Test Results:**

**GFSK Mode:**

Hopping mode	Channel	Band-edge Freq.[MHz]	Delta[dB]	Conclusion
Hopping OFF	0, Left band-edge	2399.468	-40.17	Pass
Hopping ON	--, Left band-edge	2399.516	-41.09	Pass
Hopping OFF	78, Right band-edge	2484.038	-43.28	Pass
Hopping ON	--, Right band-edge	2484.038	-43.28	Pass

**Pi/4 DQPSK Mode:**

Hopping mode	Channel	Band-edge Freq.[MHz]	Delta[dB]	Conclusion
Hopping OFF	0, Left band-edge	2399.484	-39.41	Pass
Hopping ON	--, Left band-edge	2399.532	-41.09	Pass
Hopping OFF	78, Right band-edge	2483.910	-42.59	Pass
Hopping ON	--, Right band-edge	2484.503	-45.18	Pass

**8PSK Mode:**

Hopping mode	Channel	Band-edge Freq.[MHz]	Delta[dB]	Conclusion
Hopping OFF	0, Left band-edge	2399.484	-38.69	Pass
Hopping ON	--, Left band-edge	2399.308	-40.73	Pass
Hopping OFF	78, Right band-edge	2483.926	-42.22	Pass
Hopping ON	--, Right band-edge	2484.599	-43.49	Pass

Graphical results:

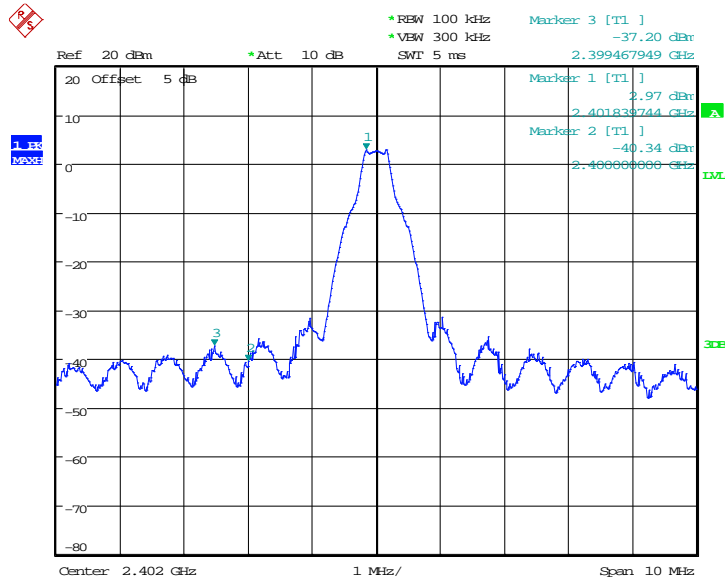

Date: 26.MAY.2016 10:57:43

GFSK Channel 0, fixed mode, left band-edge

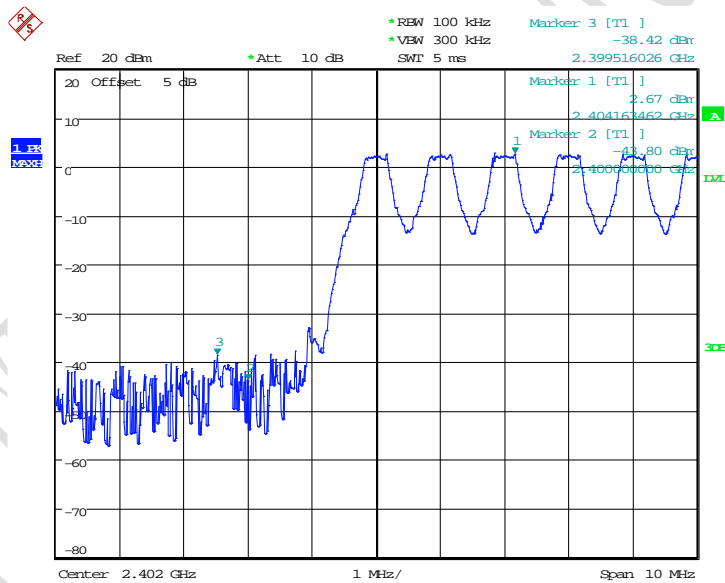

Date: 26.MAY.2016 11:02:55

GFSK Hopping mode, left band-edge

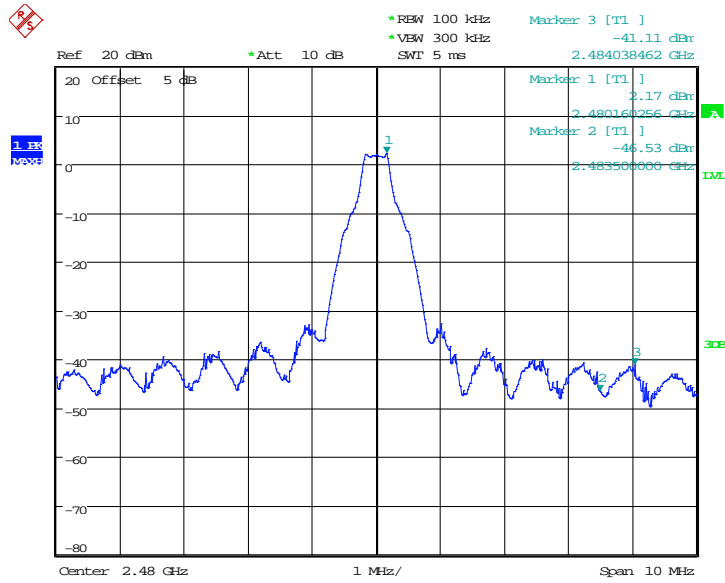

Date: 26.MAY.2016 11:06:59

GFSK Channel 78, fixed mode, right band-edge

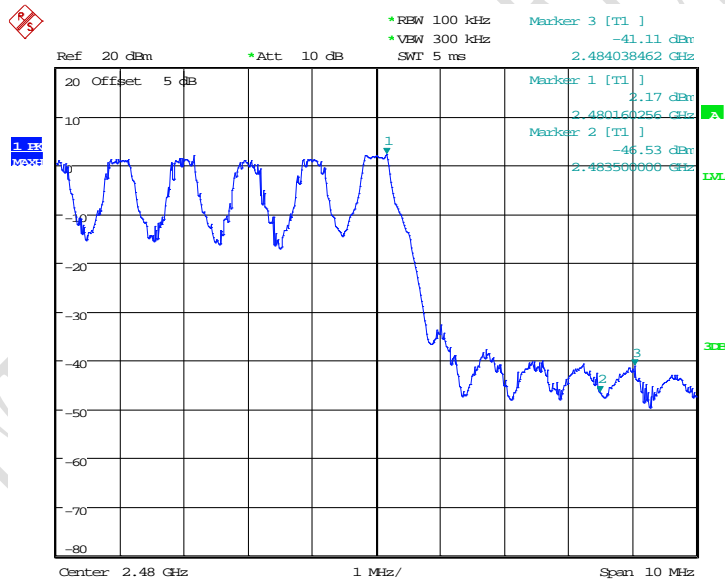

Date: 26.MAY.2016 11:08:12

GFSK Hopping mode, right band-edge

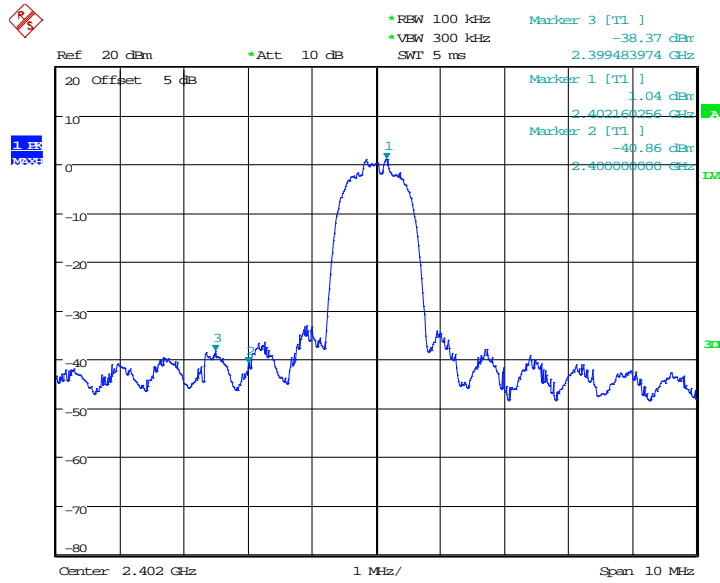

Date: 26.MAY.2016 11:16:19

Pi/4 DQPSK Channel 0, fixed mode, left band-edge

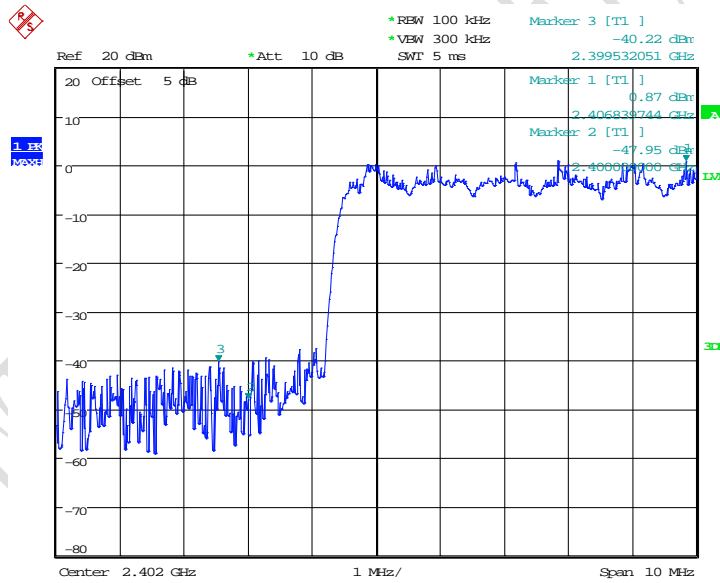

Date: 26.MAY.2016 11:20:24

Pi/4 DQPSK Hopping mode, left band-edge

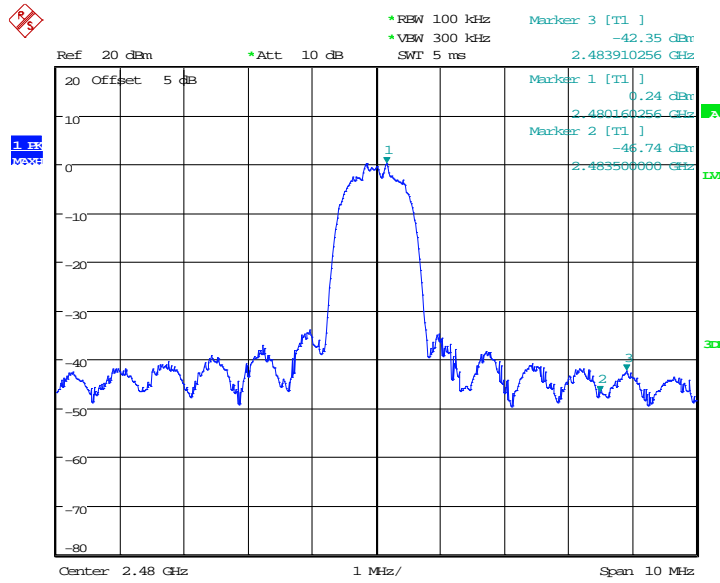

Date: 26.MAY.2016 11:11:05

Pi/4 DQPSK Channel 78, fixed mode, right band-edge

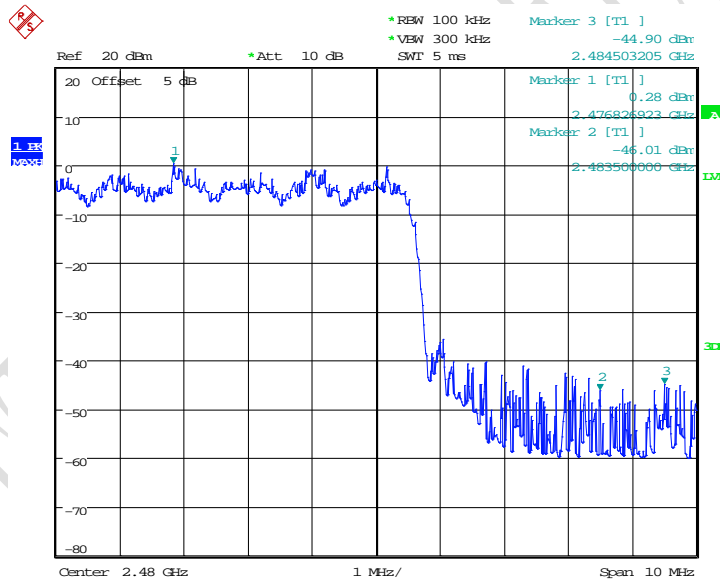

Date: 26.MAY.2016 11:14:28

Pi/4 DQPSK Hopping mode, right band-edge

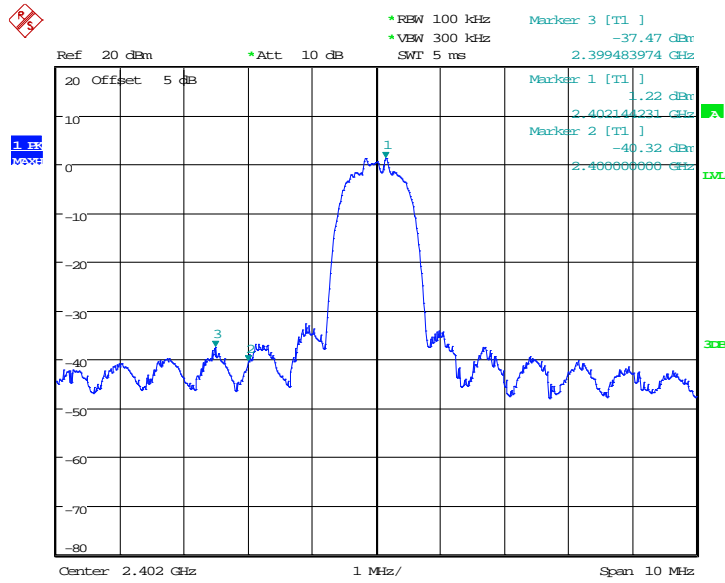

Date: 26.MAY.2016 11:22:26

8DPSK Channel 0, fixed mode, left band-edge

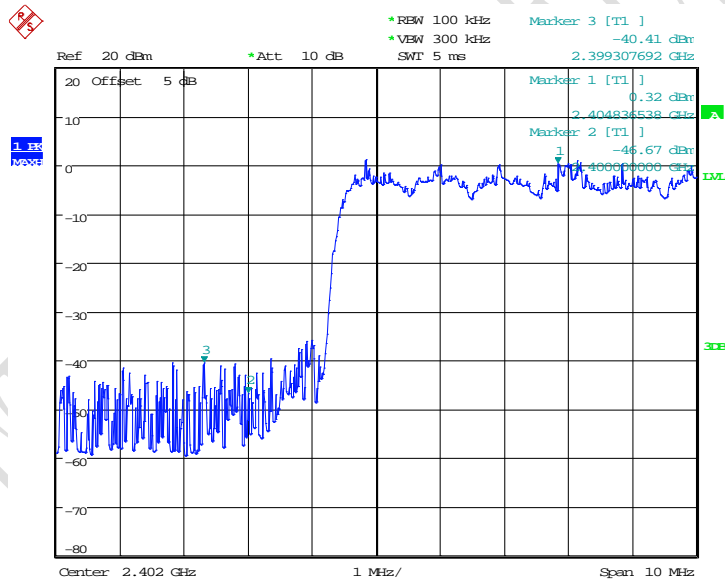

Date: 26.MAY.2016 11:25:17

8DPSK Hopping mode, left band-edge

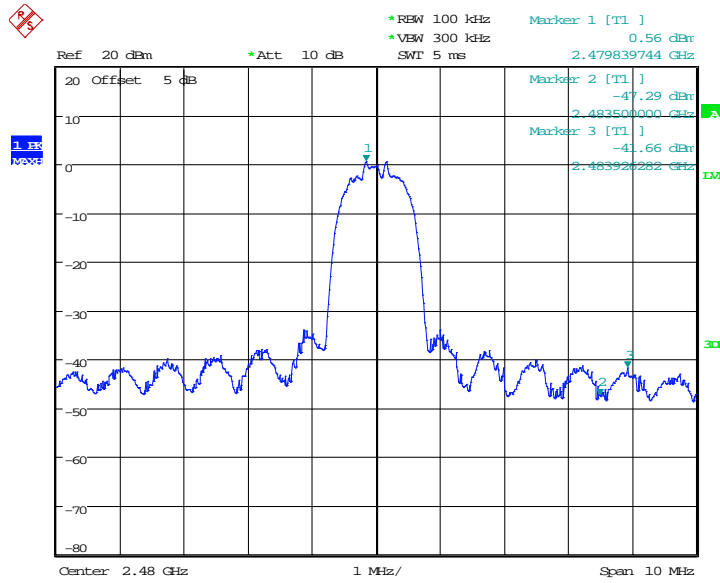

Date: 26.MAY.2016 11:28:27

8DPSK Channel 78, fixed mode, right band-edge

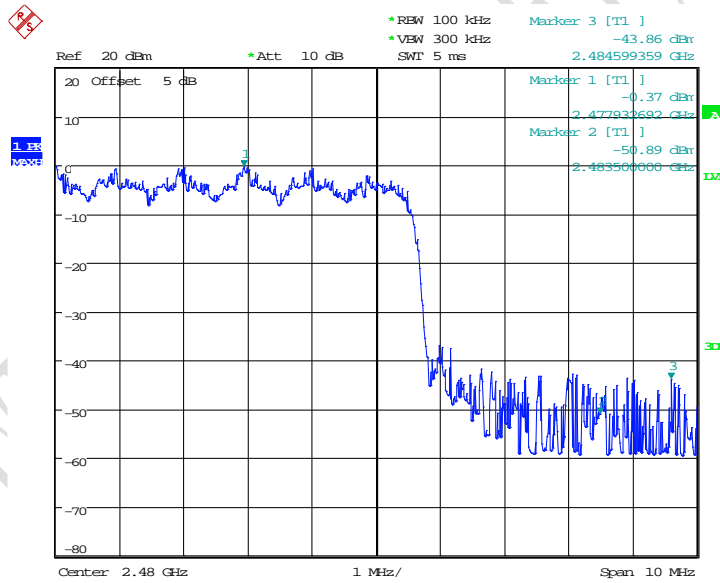

Date: 26.MAY.2016 11:32:17

8DPSK Hopping mode, right band-edge



**Radiated Limit**

Standard	Limited(dBuV/m)	
FCC 47 CFR Part 15.247(d)	Peak	74
	Average	54

**Test Setup:**

The measurement is according to ANSI C63.10 clause 11.13.

- Span: Wide enough to capture the peak level of the emission operating on the channel closest to the band edge, as well as any modulation products that fall outside of the authorized band of operation.
- Reference level offset: Corrected for gains and losses of test antenna factor, preamp gain and cable loss, so as to indicate field strength, in units of dB $\mu$ V/m at 3 m, directly on the instrument display. Alternatively, the reference level offset may be set to zero and calculations shall be provided showing the conversion of raw measured data to the field strength in dB $\mu$ V/m at 3 m.
- Reference level: As required to keep the signal from exceeding the maximum spectrum analyzer input mixer level for linear operation. In general, the peak of the spectral envelope shall be more than [10 log (OBW/RBW)] below the reference level. Specific guidance is given in 4.1.5.2..
- Attenuation: Auto (at least 10 dB preferred).
- Sweep time: Coupled.
- Resolution bandwidth: Above 1 GHz: 1 MHz
- Video bandwidth: VBW for Peak, Quasi-peak, or Average Detector Function: 3 $\times$ RBW
- Detector (unless specified otherwise): Peak and average above 1 GHz
- Trace: Max hold for final measurement; a combination of two traces, clear-write and max hold, is recommended for maximizing the emission.

**GFSK**

Channel	Test Results(dBuV/m)			Conclusion
0	Peak	2390.000MHz	49.852	Pass
	Average	2390.000MHz	34.222	
78	Peak	2483.000MHz	61.908	Pass
	Average	2483.600MHz	33.755	

Pi/4 DQPSK

Channel	Test Results(dBuV/m)			Conclusion
0	Peak	2390.000MHz	44.595	Pass
	Average	2390.000MHz	33.421	
78	Peak	2483.000MHz	45.392	Pass
	Average	2483.000MHz	34.578	

8DPSK

Channel	Test Results(dBuV/m)			Conclusion
0	Peak	2390.000MHz	43.282	Pass
	Average	2390.000MHz	32.425	
78	Peak	2483.000MHz	44.264	Pass
	Average	2483.000MHz	33.677	

Test plots:

GFSK Channel 0, fixed mode, left band-edge

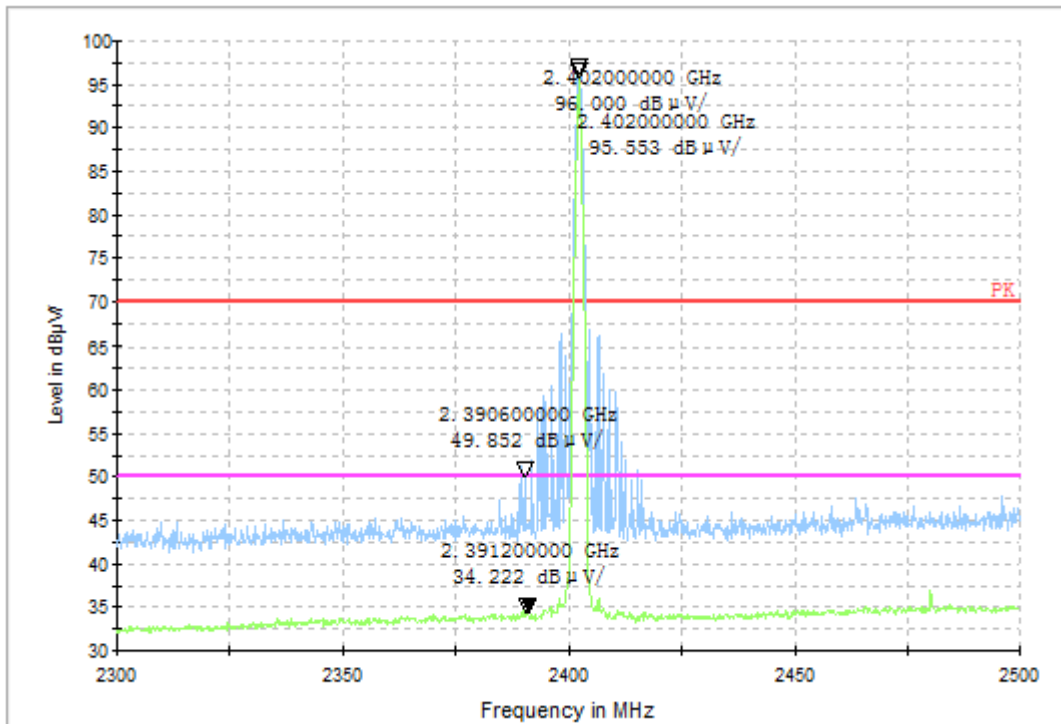

GFSK Channel 78, fixed mode, right band-edge

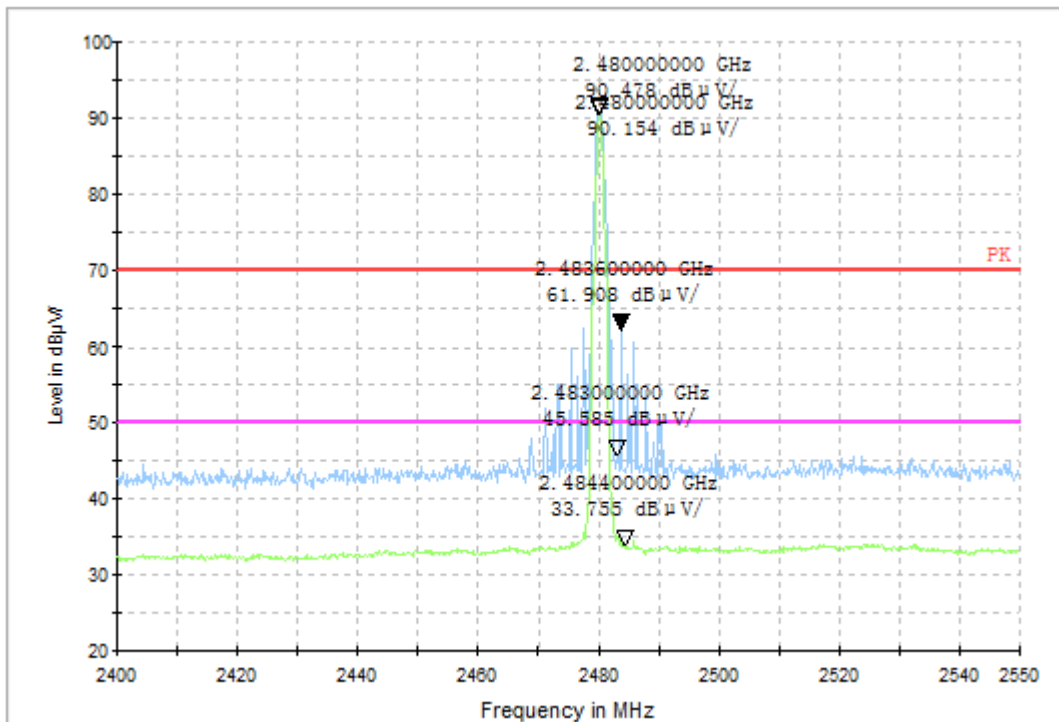

Pi/4 DQPSK Channel 0, fixed mode, left band-edge

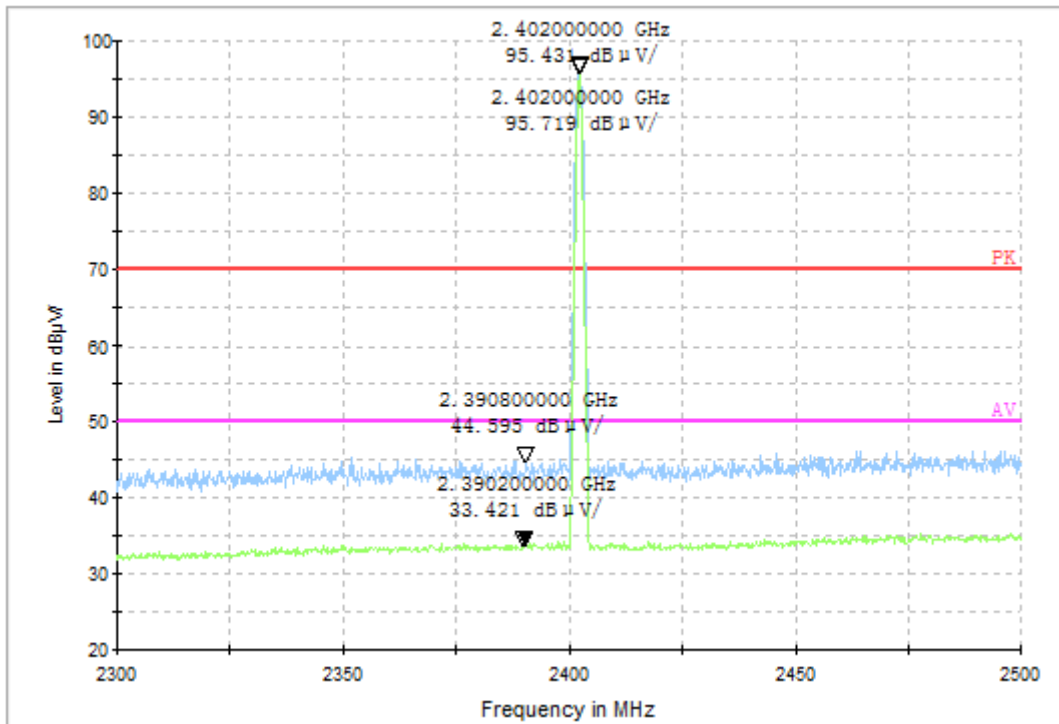

Pi/4 DQPSK Channel 78, fixed mode, right band-edge

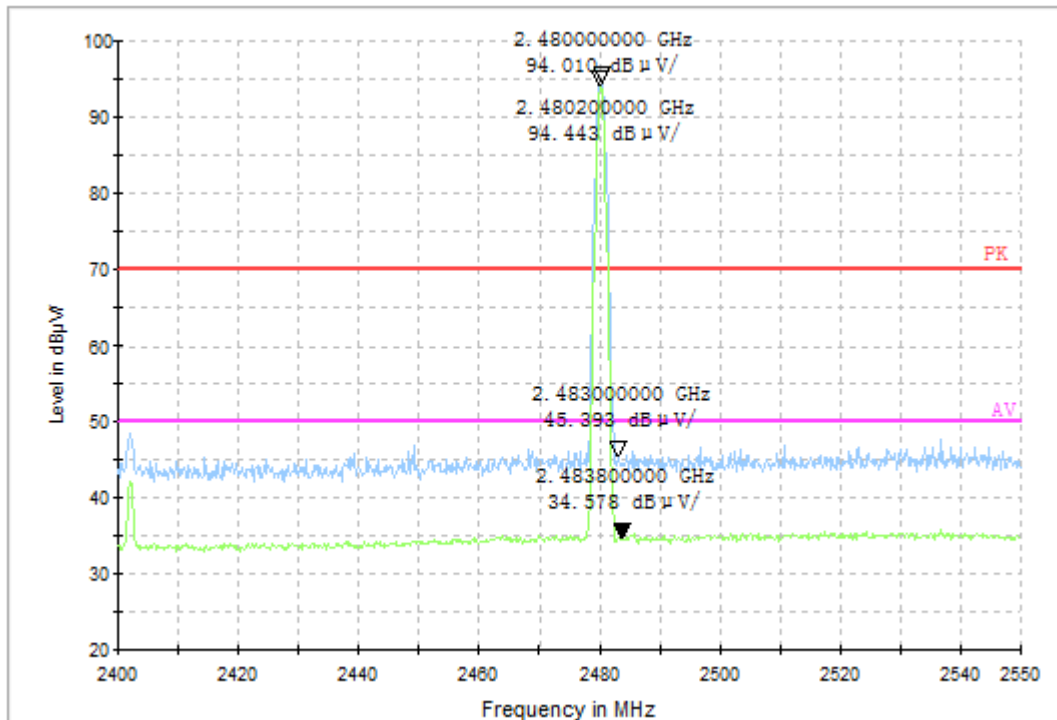

8DPSK Channel 0, fixed mode, left band-edge

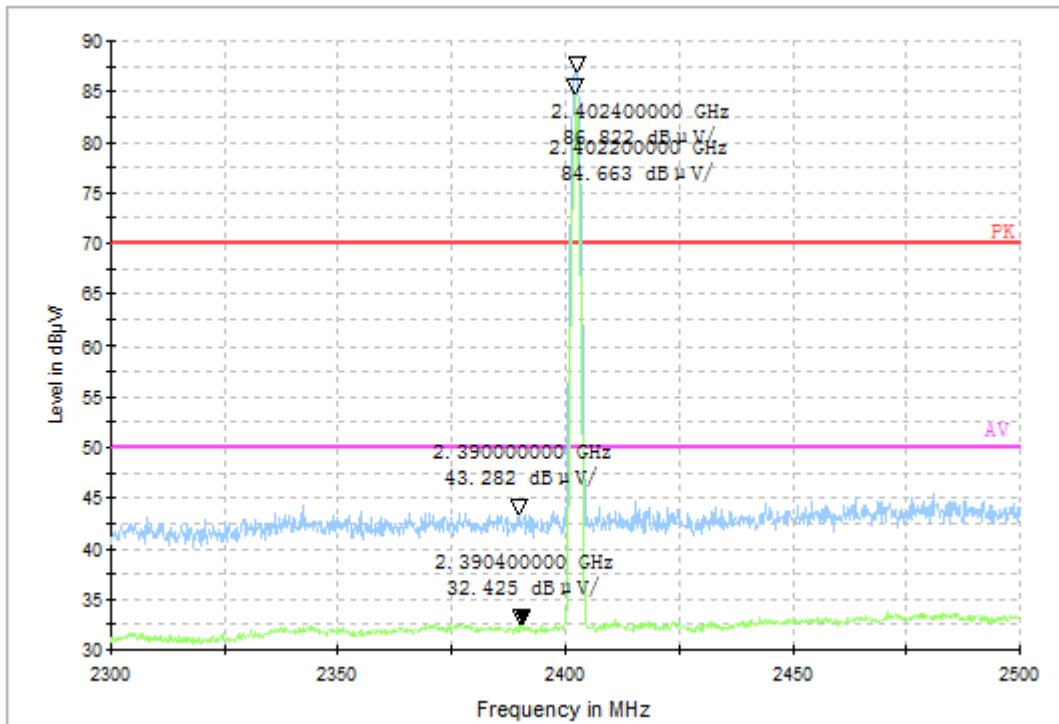

8DPSK Channel 78, fixed mode, right band-edge

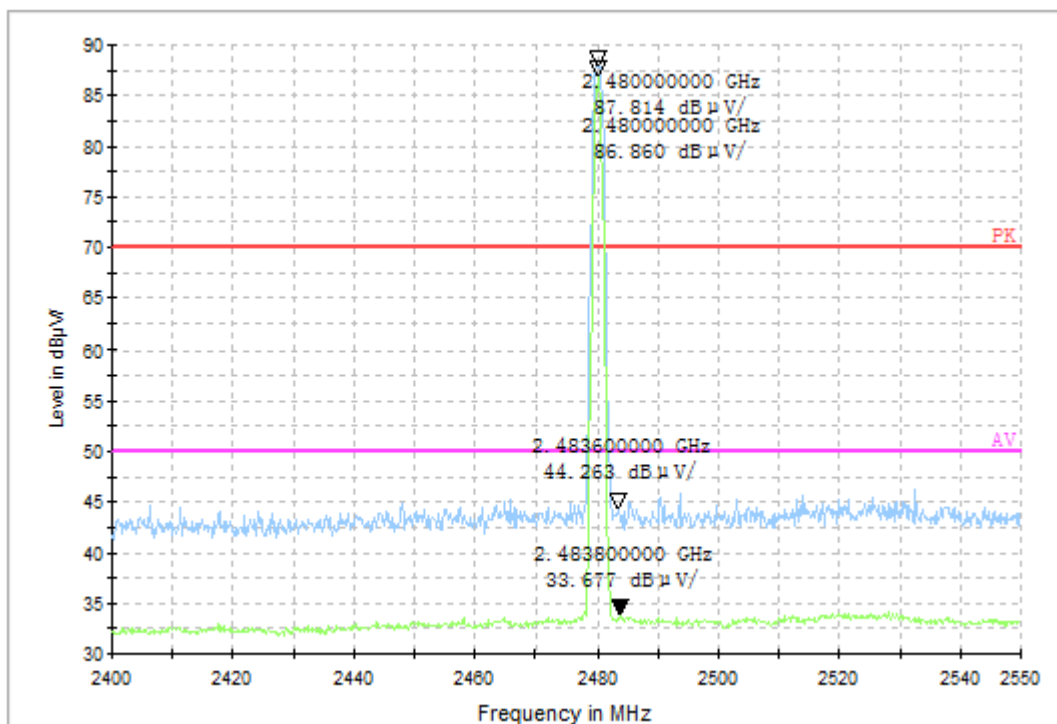

### 5.3 Frequency separation

<b>Specifications:</b>	FCC Part 15.247(a)(1)
<b>DUT Serial Number:</b>	S3/7: 356307070001895
<b>Test conditions:</b>	Ambient Temperature:15°C-35°C Relative Humidity:30%-60% Air pressure: 86-106kPa
<b>Test Results:</b>	--

#### Limit Level Construction:

According to §15.247(a)(1), Frequency hopping systems shall have hopping channel carrier frequencies separated by minimum of 25 kHz or 2/3 of the 20 dB bandwidth of the hopping channel (note), whichever is greater.

Note: it is for the power of less than 125 mw, and for others it is 20 dB bandwidth of the hopping channel.

#### Test Setup

The BLUETOOTH TESTER was used to set the TX channel and power level. The transmitter output is connected to Spectrum analyzer through a coupling.

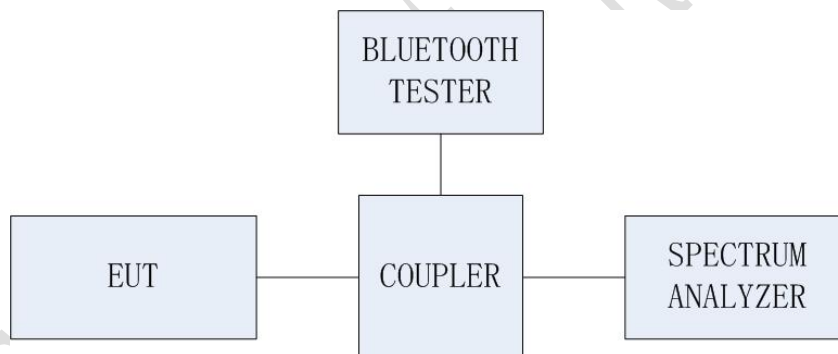

#### Test Procedure

The spectrum analyzer is set to:

1. 20dBc Bandwidth: Span = 3 MHz, RBW=20 kHz, VBW=50 kHz, Sweep=auto.
2. Carrier Frequency Separation: Span = 3 MHz, RBW=100 kHz, VBW=300 kHz, Sweep=auto.

The trace was allowed to stabilize. The marker-delta function was used to determine the separation between the peaks of the adjacent channels.

The measurement is made according to Public notice FCC Public Notice DA 00-705, March 2000, and ANSI C63.10-2013.

**Note:** --

Test Result:

Channel separation	20dB Bandwidth(kHz)	Limit(kHz)	Result	
<b>GFSK</b>				
998	Ch 0	1034	>25	Pass
	Ch 39	1058	>25	Pass
	Ch 78	966	>25	Pass
<b>Pi/4 DQPSK</b>				
888	Ch 0	1274	>25	Pass
	Ch 39	1269	>25	Pass
	Ch 78	1260	>25	Pass
<b>8DPSK</b>				
996	Ch 0	1264	>25	Pass
	Ch 39	1274	>25	Pass
	Ch 78	1255	>25	Pass

Graphical results:

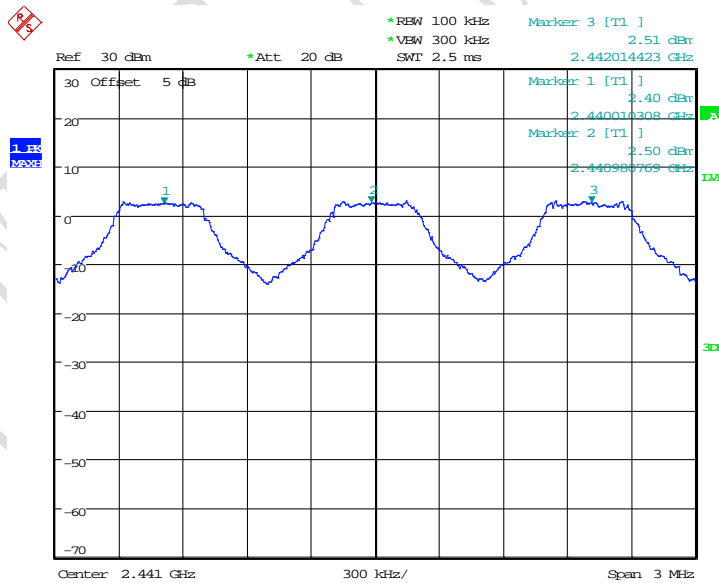

Date: 26.MAY.2016 11:59:52

Channel Separation (GFSK)

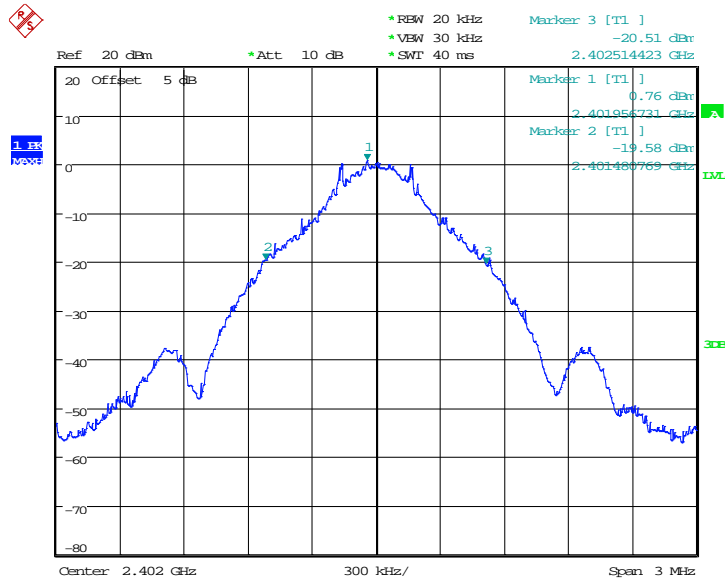

Date: 26.MAY.2016 11:41:11

20dB Bandwidth (GFSK Ch 0)

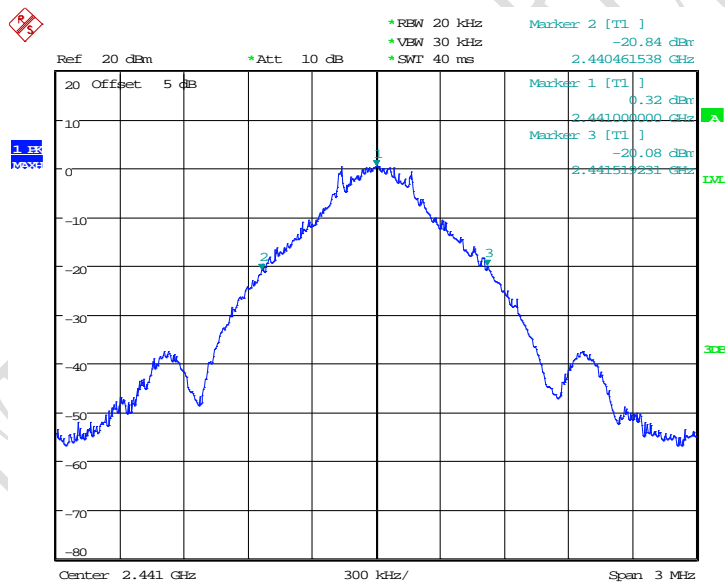

Date: 26.MAY.2016 11:42:24

20dB Bandwidth (GFSK Ch 39)



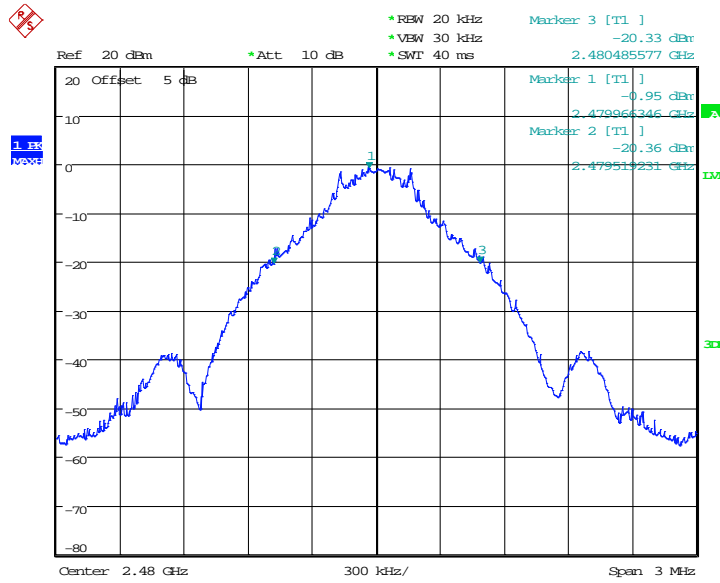

Date: 26.MAY.2016 11:43:16

20dB Bandwidth (GFSK Ch 78)

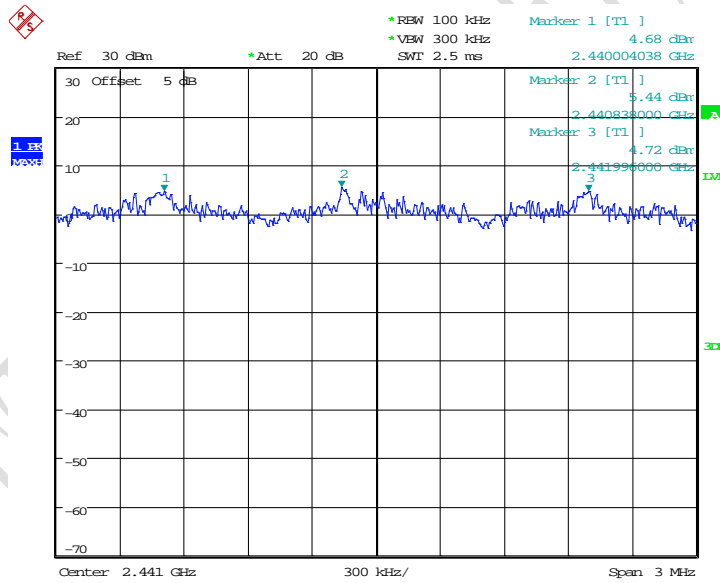

Date: 26.MAY.2016 13:34:20

Channel Separation (Pi/4 DQPSK)

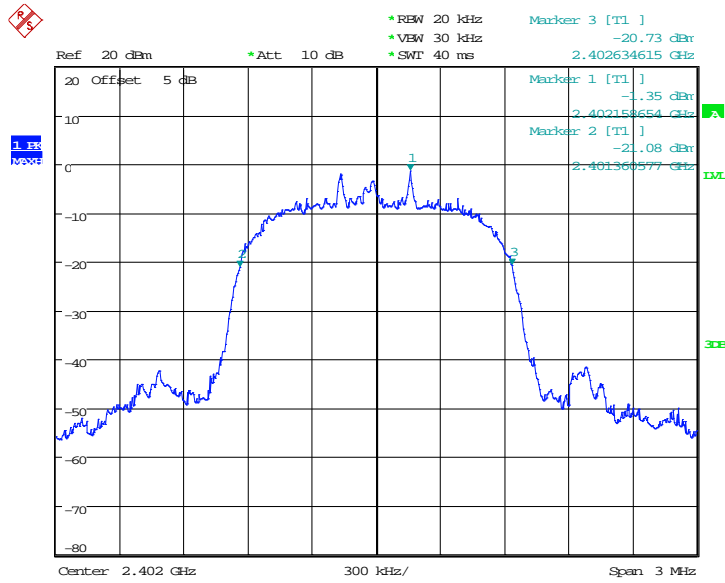

Date: 26.MAY.2016 11:46:11

20dB Bandwidth (Pi/4 DQPSK Ch0)

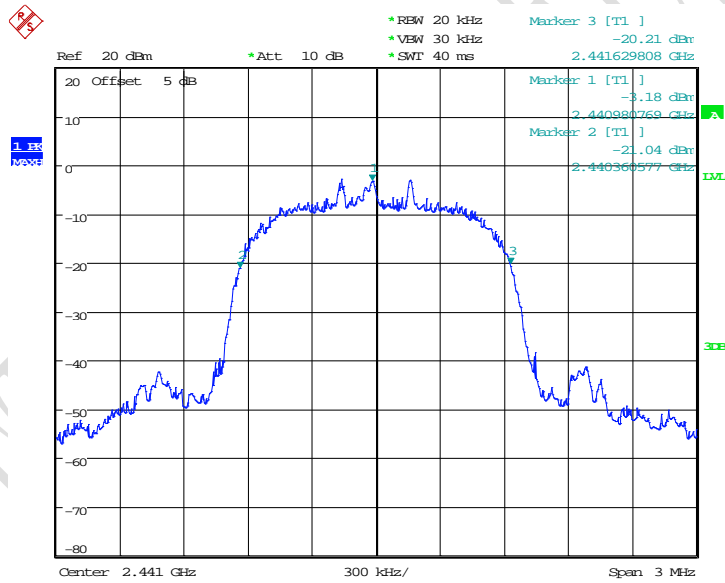

Date: 26.MAY.2016 11:45:00

20dB Bandwidth (Pi/4 DQPSK Ch39)

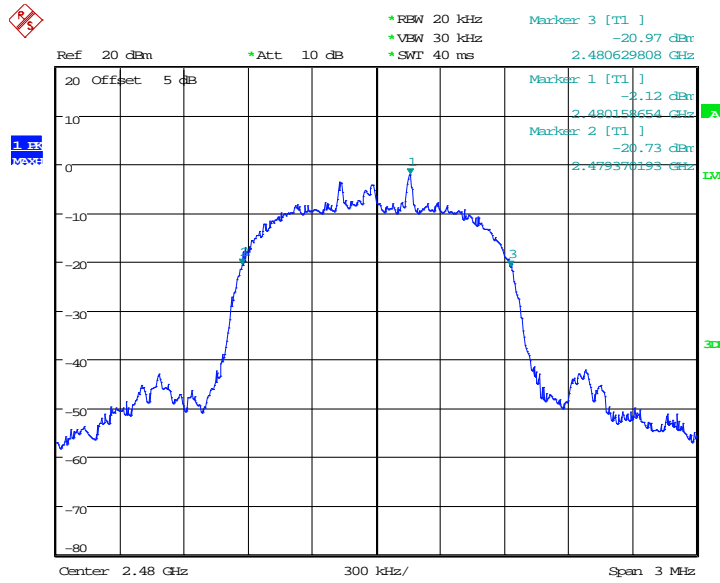

Date: 26.MAY.2016 11:44:21

20dB Bandwidth (Pi/4 DQPSK Ch78)

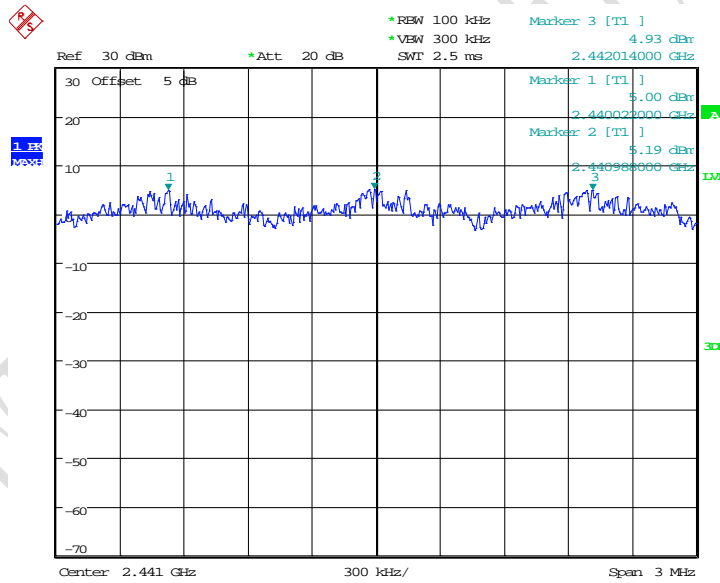

Date: 26.MAY.2016 13:36:26

Channel Separation (8DPSK)

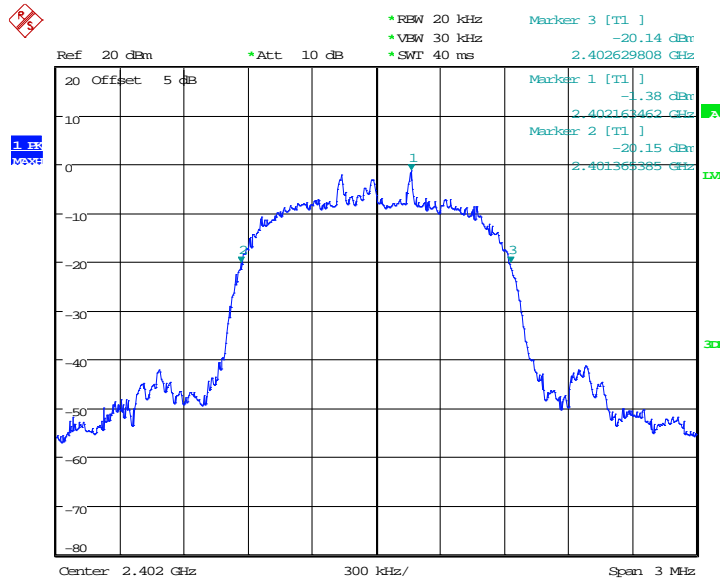

Date: 26.MAY.2016 11:47:02

20dB Bandwidth (8DPSK Ch0)

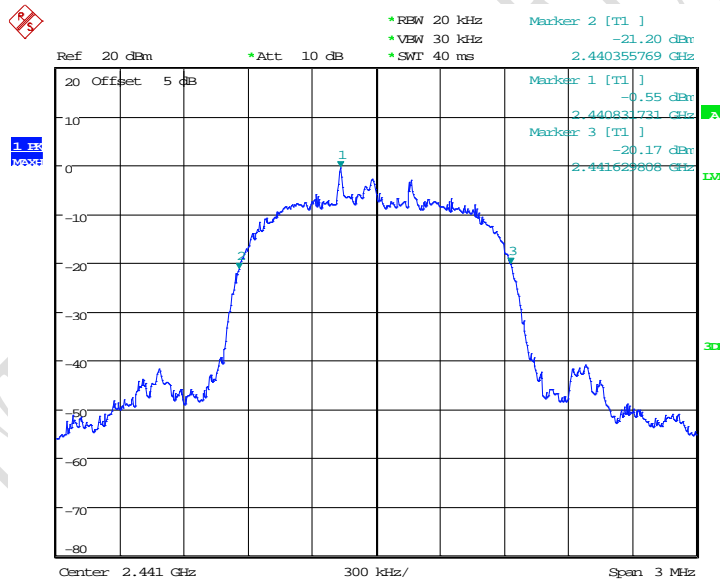

Date: 26.MAY.2016 11:47:51

20dB Bandwidth (8DPSK Ch39)

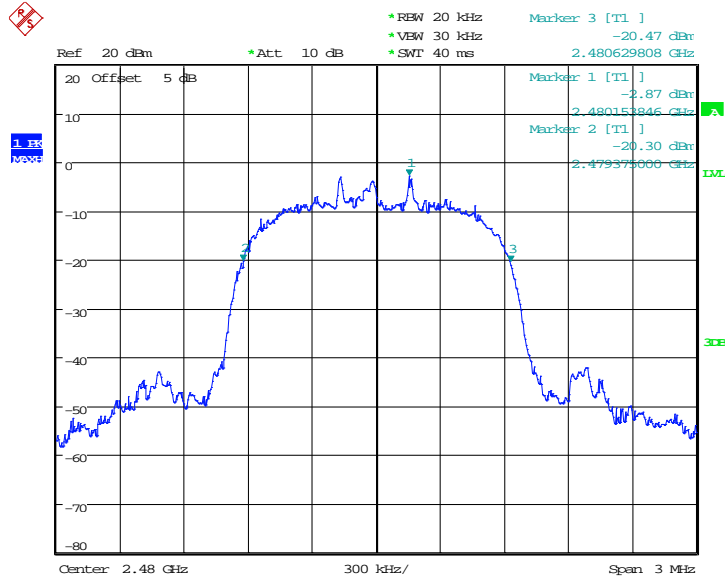

Date: 26.MAY.2016 11:48:45

20dB Bandwidth (8DPSK Ch78)

**5.4 Number of hopping frequency**

<b>Specifications:</b>	FCC Part 15.247(a)(1)(ii)
<b>DUT Serial Number:</b>	S3/7: 356307070001895
<b>Test conditions:</b>	Ambient Temperature:15°C-35°C Relative Humidity:30%-60% Air pressure: 86-106kPa
<b>Test Results:</b>	--

**Limit Level Construction:**

According to §15.247(a)(1)(ii), Frequency hopping systems operating in the 2400 MHz - 2483.5 MHz bands shall use at least 15 hopping frequencies.

**Test Setup**

The BLUETOOTH TESTER was used to set the TX channel and power level. The transmitter output is connected to Spectrum analyzer through a coupling.

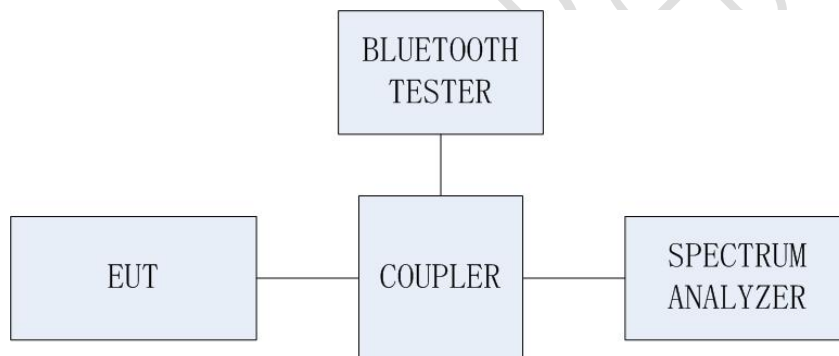

**Test Procedure**

The Bluetooth frequency hopping function of the EUT was enabled. The spectrum analyzer was set to:

1. Span = the frequency band of operation, i.e. 2400-2441MHz and 2441-2484 MHz
2. RBW = 500 KHz
3. VBW = 500 KHz
4. Sweep = auto

The trace was allowed to stabilize.

The measurement is made according to Public notice FCC Public Notice DA 00-705, March 2000, and ANSI C63.10-2013.

**Note: --**

Test Result:

Modulation	No. of channels	Limit (No. of Ch)	Result
GFSK	79	>75	Pass
Pi/4 DQPSK	79	>75	Pass
8DPSK	79	>75	Pass

Graphical results:

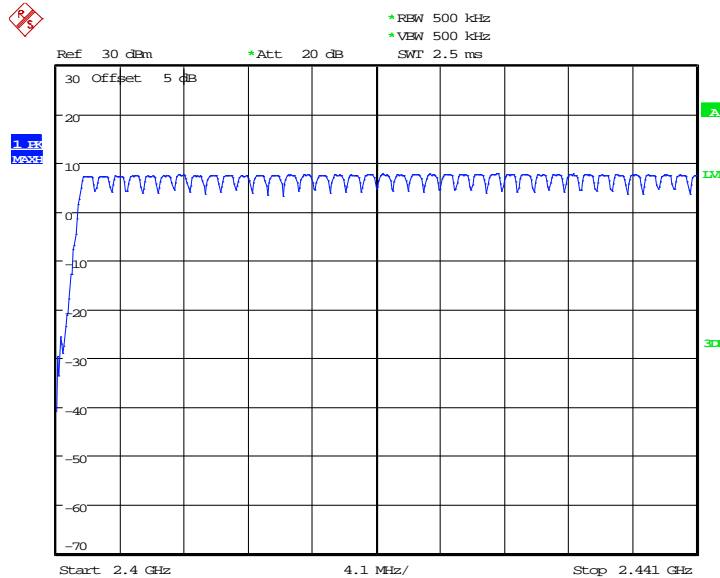

Date: 26.MAY.2016 13:42:26

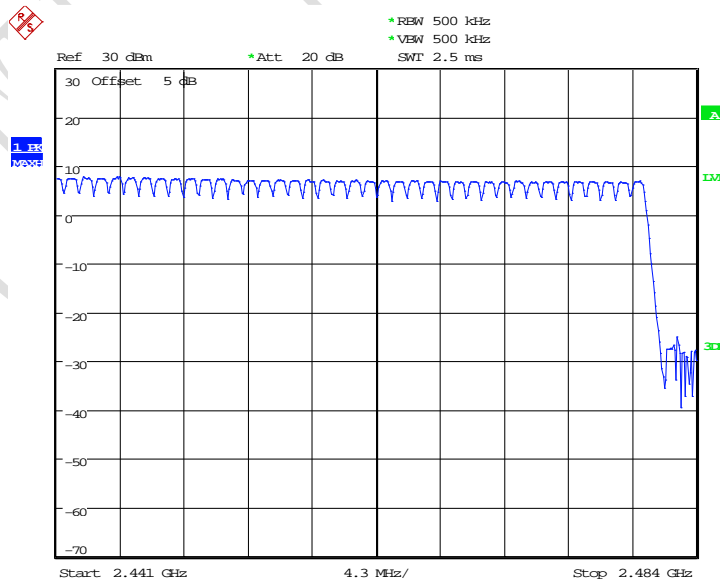

Date: 26.MAY.2016 13:46:06

Channel Number (GFSK)

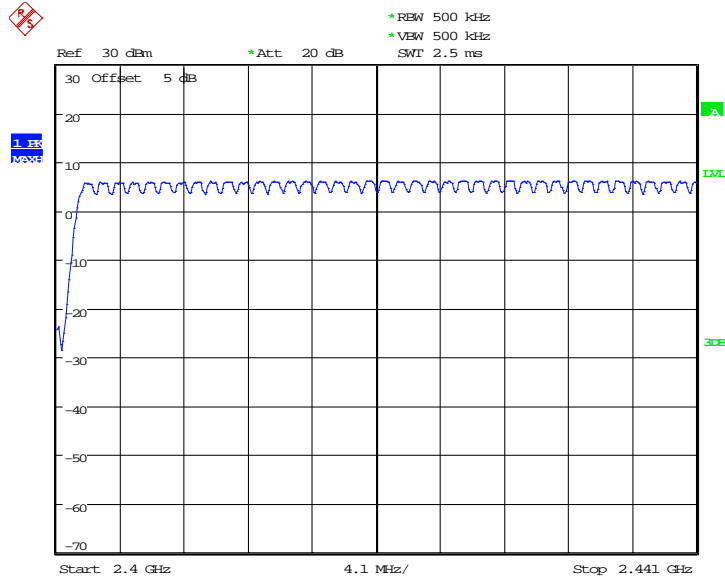

Date: 26.MAY.2016 14:01:48

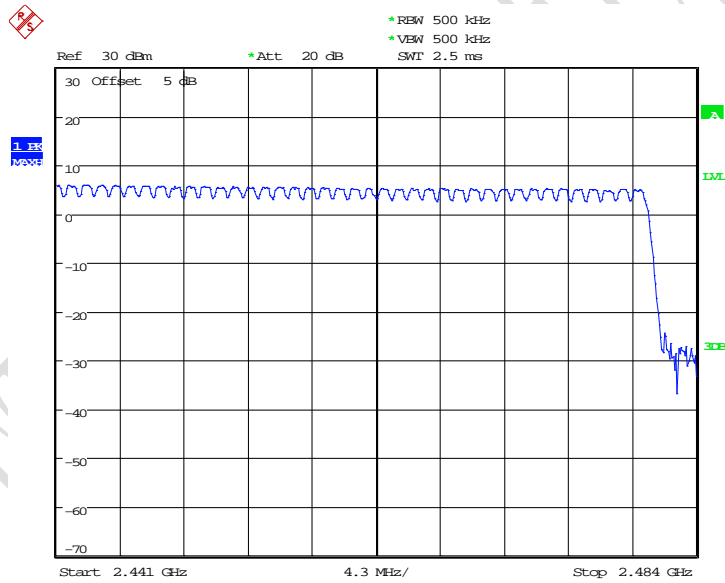

Date: 26.MAY.2016 13:54:05

Channel Number (Pi/4 DQPSK)



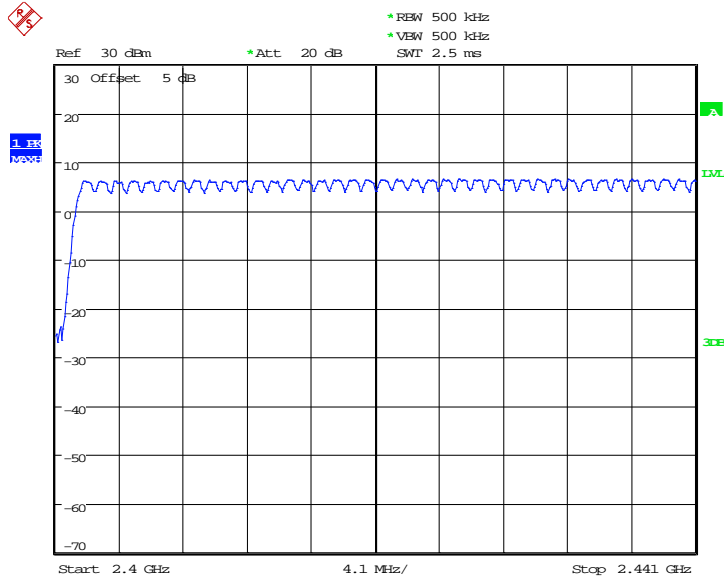

Date: 26.MAY.2016 14:10:13

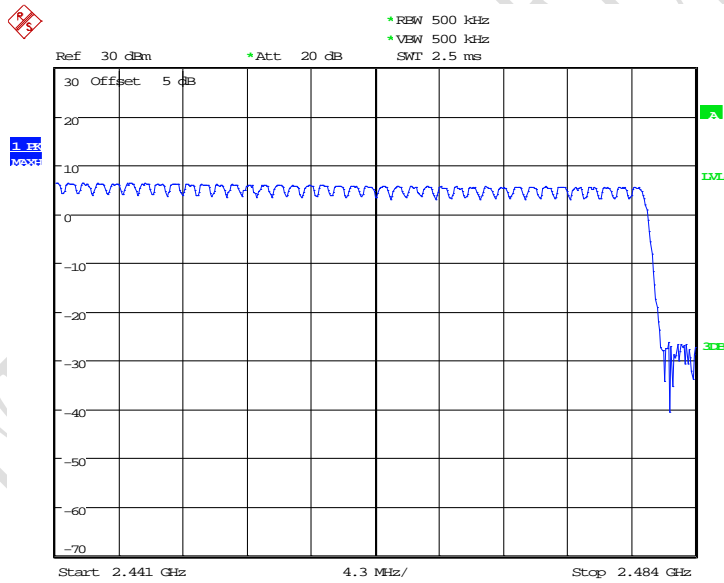

Date: 26.MAY.2016 14:17:07

Channel Number (8DPSK)

### 5.5 Time of occupancy

<b>Specifications:</b>	FCC Part 15.247(a)(1)(iii)
<b>DUT Serial Number:</b>	S3/7: 356307070001895
<b>Test conditions:</b>	Ambient Temperature:15°C-35°C Relative Humidity:30%-60% Air pressure: 86-106kPa
<b>Test Results:</b>	--

#### Limit

According to §15.247(a)(1)(iii), Frequency hopping systems operating in the 2400 MHz - 2483.5 MHz bands. The average time of occupancy on any channels shall not greater than 0.4 s within a period 0.4 s multiplied by the number of hopping channels employed.

#### Test Setup

The BLUETOOTH TESTER was used to set the TX channel and power level. The transmitter output is connected to Spectrum analyzer through a coupling.

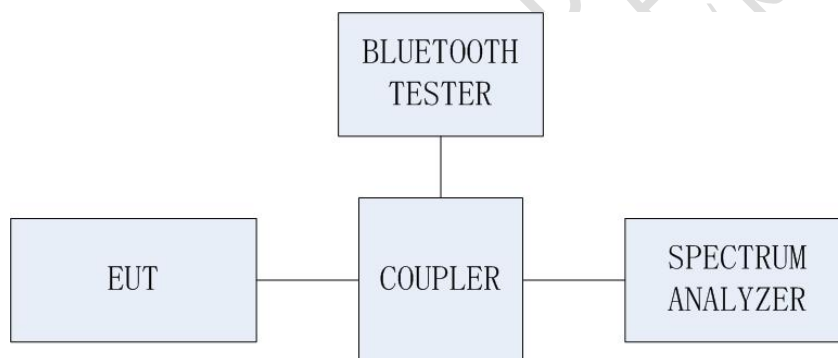

#### Test Procedure

The spectrum analyzer is set to:

1. Span = zero span
2. RBW = 1 MHz
3. VBW = 3 MHz
4. Sweep = as necessary to capture the entire dwell time per channel

The marker-delta function was used to determine the dwell time.

The measurement is made according to Public notice FCC Public Notice DA 00-705, March 2000, and ANSI C63.10-2013.

**Test Result:**

GFSK DH1:

$0.368 * (1600/2) / 79 * 31.6 = 118\text{ms}$

Pulse time[ms]	Total dwell[ms]	Period time[s]	Result
0.368	118	31.6	Pass

GFSK DH3:

$1.628 * (1600/4) / 79 * 31.6 = 260\text{ms}$

Pulse time[ms]	Total dwell[ms]	Period time[s]	Result
1.628	260	31.6	Pass

GFSK DH5:

$2.862 * (1600/6) / 79 * 31.6 = 305\text{ms}$

Pulse time[ms]	Total dwell[ms]	Period time[s]	Result
2.862	305	31.6	Pass

Pi/4 DQPSK 2DH1:

$0.379 * (1600/2) / 79 * 31.6 = 121\text{ms}$

Pulse time[ms]	Total dwell[ms]	Period time[s]	Result
0.379	121	31.6	Pass

Pi/4 DQPSK 2DH3:

$1.625 * (1600/4) / 79 * 31.6 = 260\text{ms}$

Pulse time[ms]	Total dwell[ms]	Period time[s]	Result
1.625	260	31.6	Pass

Pi/4 DQPSK 2DH5:

$2.869 * (1600/6) / 79 * 31.6 = 306\text{ms}$

Pulse time[ms]	Total dwell[ms]	Period time[s]	Result
2.869	306	31.6	Pass

8DPSK 3DH1:

$0.380 * (1600/2) / 79 * 31.6 = 122\text{ms}$

Pulse time[ms]	Total dwell[ms]	Period time[s]	Result
0.380	122	31.6	Pass

8DPSK 3DH3:

$1.625 * (1600/4) / 79 * 31.6 = 260\text{ms}$

Pulse time[ms]	Total dwell[ms]	Period time[s]	Result
1.625	260	31.6	Pass

8DPSK 3DH5:

$2.891 * (1600/6) / 79 * 31.6 = 308\text{ms}$

Pulse time[ms]	Total dwell[ms]	Period time[s]	Result
2.891	308	31.6	Pass

Graphical results:

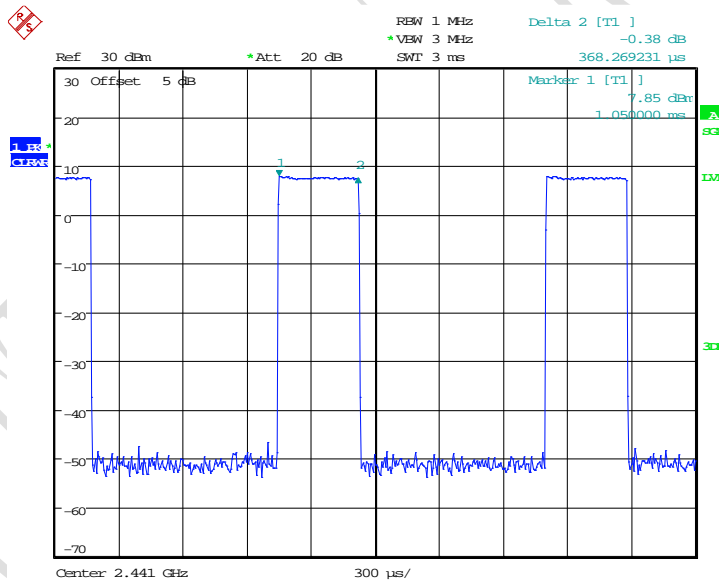

GFSK DH1

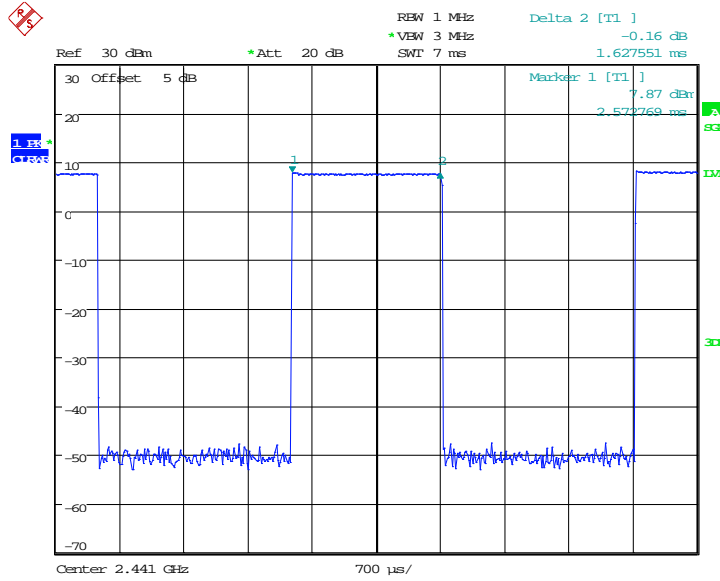

Date: 26.MAY.2016 14:38:09

### GFSK DH3

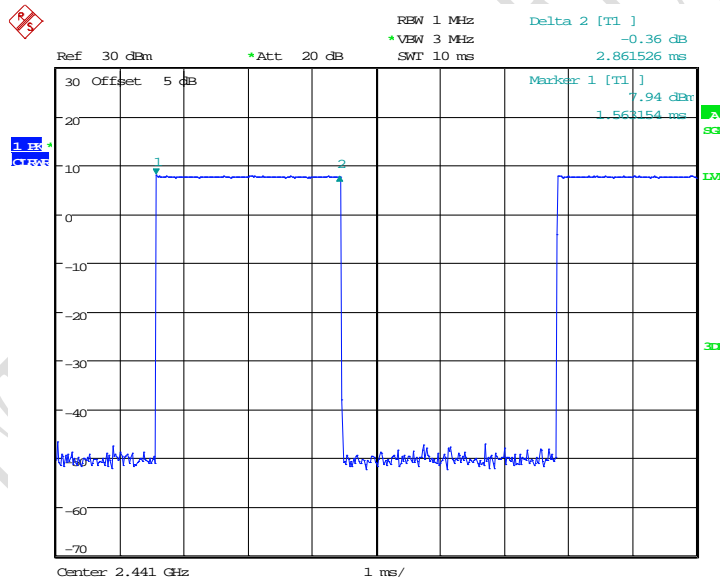

Date: 26.MAY.2016 14:39:11

### GFSK DH5

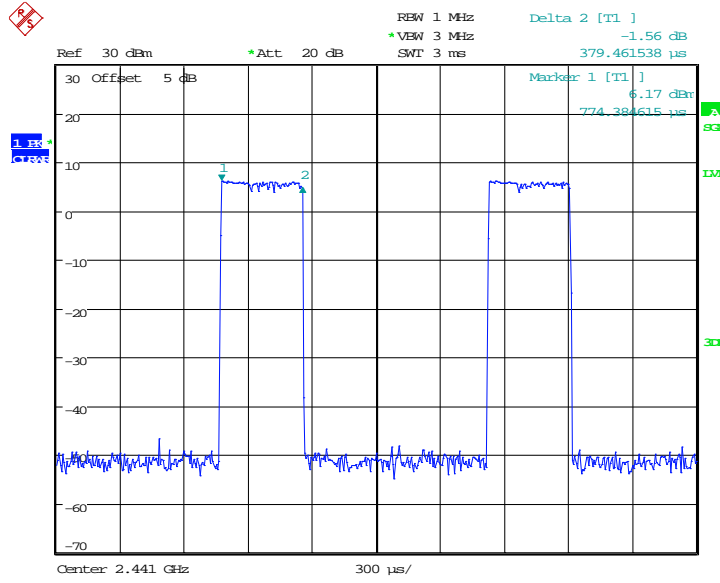

Date: 26.MAY.2016 14:40:17

### Pi/4 DQPSK 2DH1

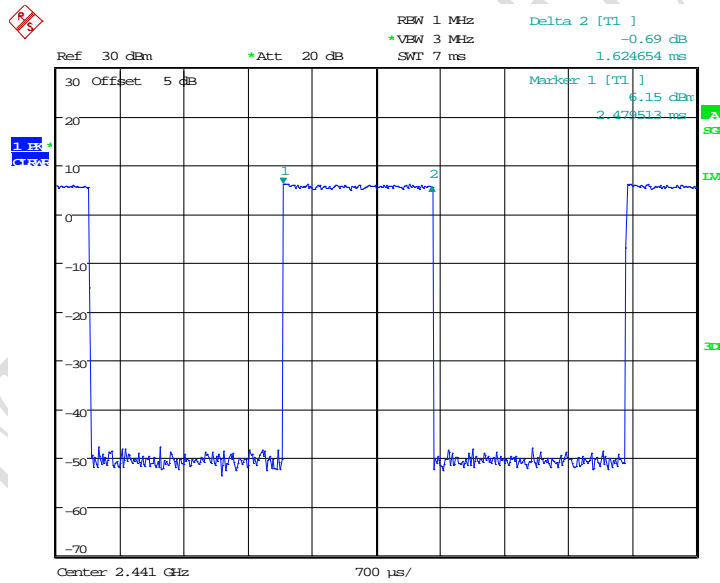

Date: 26.MAY.2016 14:40:55

### Pi/4 DQPSK 2DH3

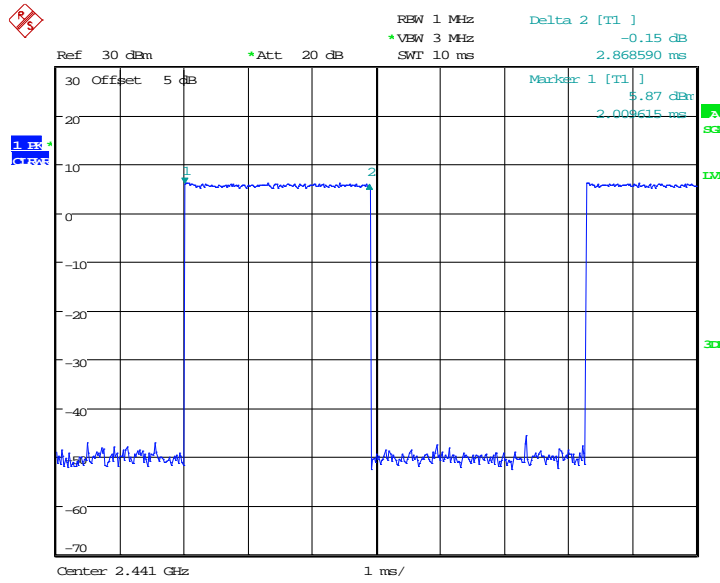

Date: 26.MAY.2016 14:42:08

### Pi/4 DQPSK 2DH5

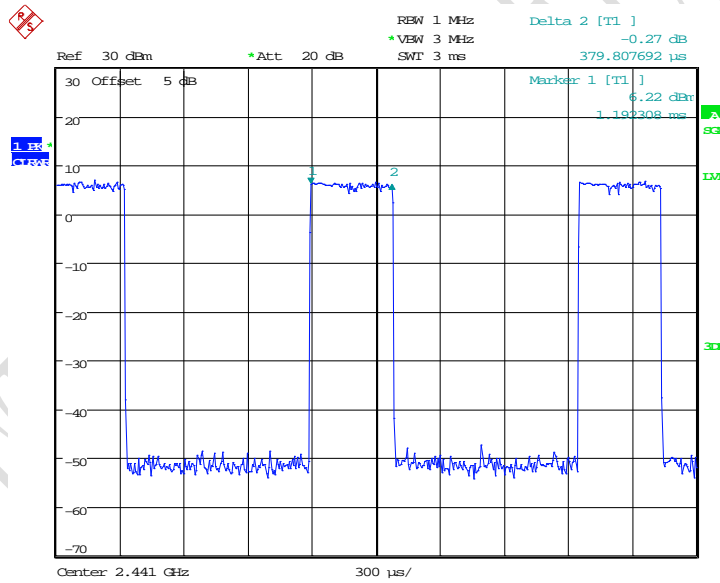

Date: 26.MAY.2016 14:42:54

### 8DPSK 3DH1

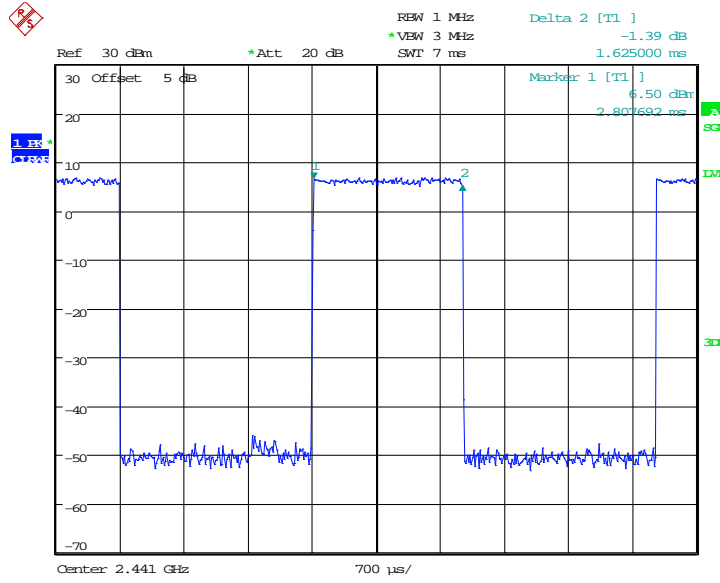

Date: 26.MAY.2016 14:43:44

### 8DPSK 3DH3

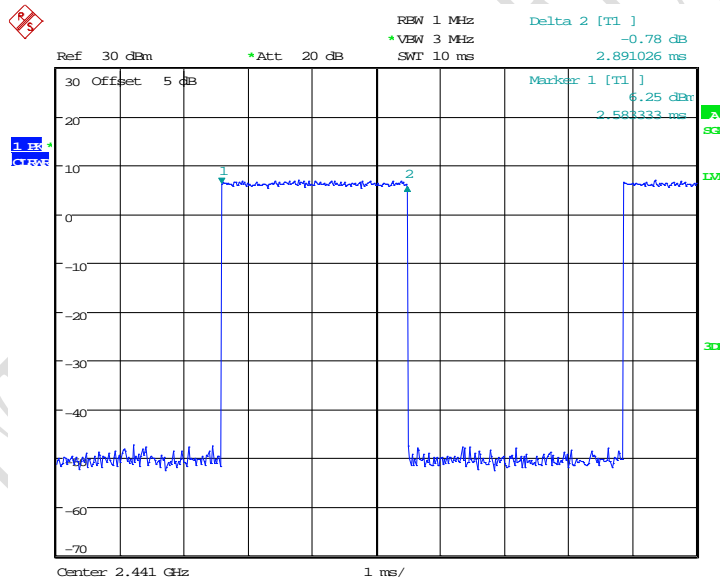

Date: 26.MAY.2016 14:44:16

### 8DPSK 3DH5



### 5.6 Spurious Measurement (Conducted)

<b>Specifications:</b>	FCC Part 15.209(a), 15.205(a)
<b>DUT Serial Number:</b>	S3/7: 356307070001895
<b>Test conditions:</b>	Ambient Temperature:15°C-35°C Relative Humidity:30%-60% Air pressure: 86-106kPa
<b>Test Results:</b>	--

#### Limit

In any 100 kHz bandwidth outside the frequency band in which the spread spectrum or digitally modulated intentional radiator is operating, the radio frequency power that is produced by the intentional radiator shall be at least 20 dB below that in the 100 kHz bandwidth within the band that contains the highest level of the desired power, based on either an RF conducted or a radiated measurement. Attenuation below the general limits specified in Section 15.209(a) is not required. In addition, radiated emissions which fall in the restricted bands, as defined in Section 15.205(a), must also comply with the radiated emission limits specified in Section 15.209(a) (see Section 15.205(c)).

#### Test Setup

The BLUETOOTH TESTER was used to set the TX channel and power level. The transmitter output is connected to Spectrum analyzer through a coupling.

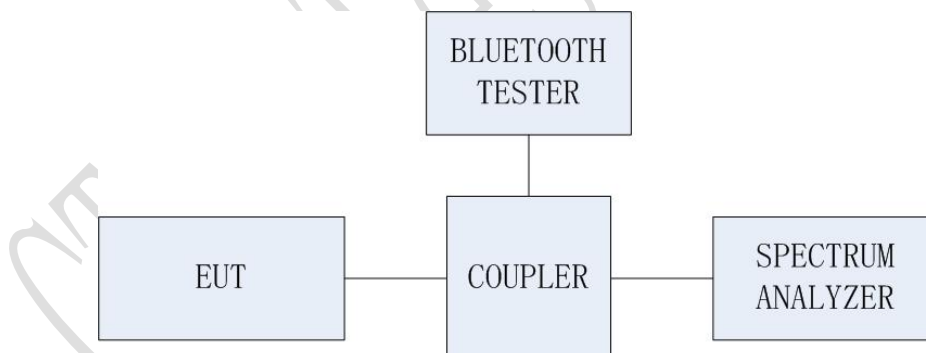

#### Test Procedure

Conducted RF measurements of the transmitter output were made to confirm that the EUT antenna port conducted emissions meet the specified limit and to identify any spurious signals that require further investigation or measurements on the radiated emissions site. The transmitter output is connected to the spectrum analyzer. The resolution bandwidth is set to 100 KHz. The video bandwidth is set to 300 KHz. Measurements are made over the 30 MHz to 26 GHz range with the transmitter set to the lowest, middle, and highest channels.

The measurement is made according to Public notice FCC Public Notice DA 00-705, March 2000, and ANSI C63.10-2013.

**Test Result:**

**GFSK**

Channel	Frequency Range	Results
0	Center Frequency	Pass
	30 MHz – 1 GHz	Pass
	1 GHz – 3 GHz	Pass
	3 GHz – 10 GHz	Pass
	10 GHz – 26.5 GHz	Pass
39	Center Frequency	Pass
	30 MHz – 1 GHz	Pass
	1 GHz – 3 GHz	Pass
	3 GHz – 10 GHz	Pass
	10 GHz – 26.5 GHz	Pass
78	Center Frequency	Pass
	30 MHz – 1 GHz	Pass
	1 GHz – 3 GHz	Pass
	3 GHz – 10 GHz	Pass
	10 GHz – 26.5 GHz	Pass

**Pi/4 DQPSK**

Channel	Frequency Range	Results
0	Center Frequency	Pass
	30 MHz – 1 GHz	Pass
	1 GHz – 3 GHz	Pass
	3 GHz – 10 GHz	Pass
	10 GHz – 26.5 GHz	Pass
39	Center Frequency	Pass
	30 MHz – 1 GHz	Pass
	1 GHz – 3 GHz	Pass
	3 GHz – 10 GHz	Pass
	10 GHz – 26.5 GHz	Pass

Report No.: B16X50179-BT\_Rev1

78	Center Frequency	Pass
	30 MHz – 1 GHz	Pass
	1 GHz – 3 GHz	Pass
	3 GHz – 10 GHz	Pass
	10 GHz – 26.5 GHz	Pass

**8DPSK**

Channel	Frequency Range	Results
0	Center Frequency	Pass
	30 MHz – 1 GHz	Pass
	1 GHz – 3 GHz	Pass
	3 GHz – 10 GHz	Pass
	10 GHz – 26.5 GHz	Pass
39	Center Frequency	Pass
	30 MHz – 1 GHz	Pass
	1 GHz – 3 GHz	Pass
	3 GHz – 10 GHz	Pass
	10 GHz – 26.5 GHz	Pass
78	Center Frequency	Pass
	30 MHz – 1 GHz	Pass
	1 GHz – 3 GHz	Pass
	3 GHz – 10 GHz	Pass
	10 GHz – 26.5 GHz	Pass

Graphical results:

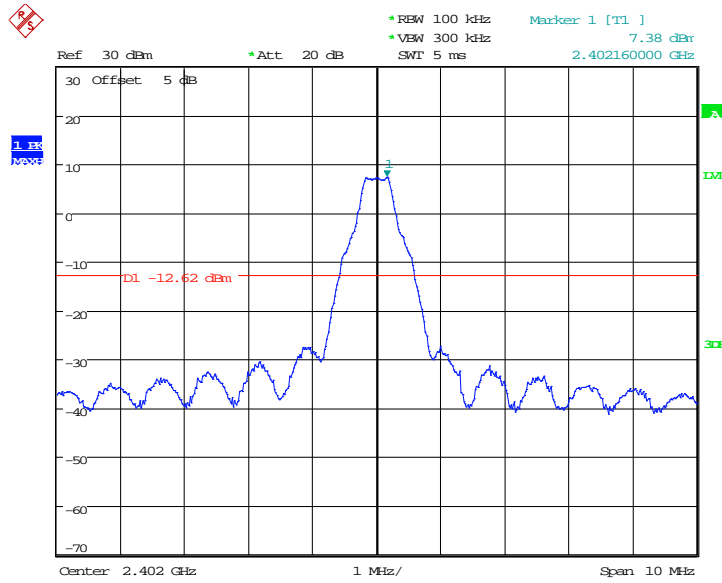

Date: 26.MAY.2016 14:58:24

### GFSK CH0 Center Frequency

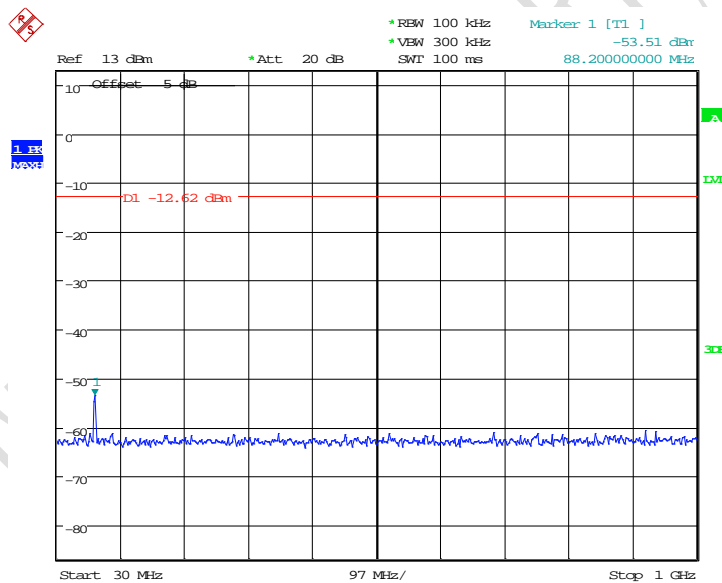

Date: 26.MAY.2016 14:59:13

### GFSK CH0 30MHz - 1GHz

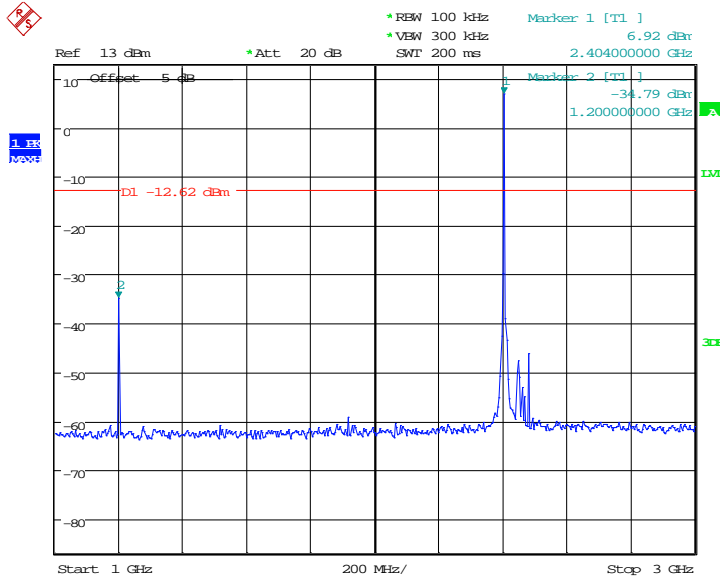

Date: 26.MAY.2016 15:00:51

### GFSK CH0 1GHz - 3GHz

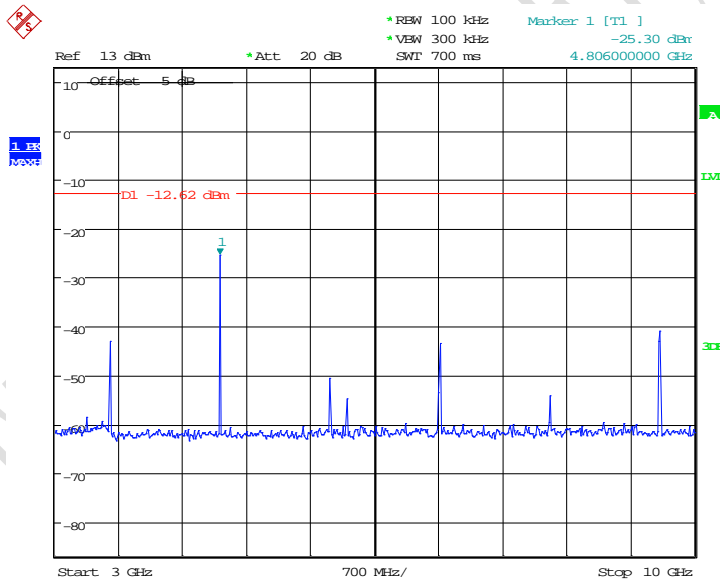

Date: 26.MAY.2016 15:01:41

### GFSK CH0 3GHz - 10GHz

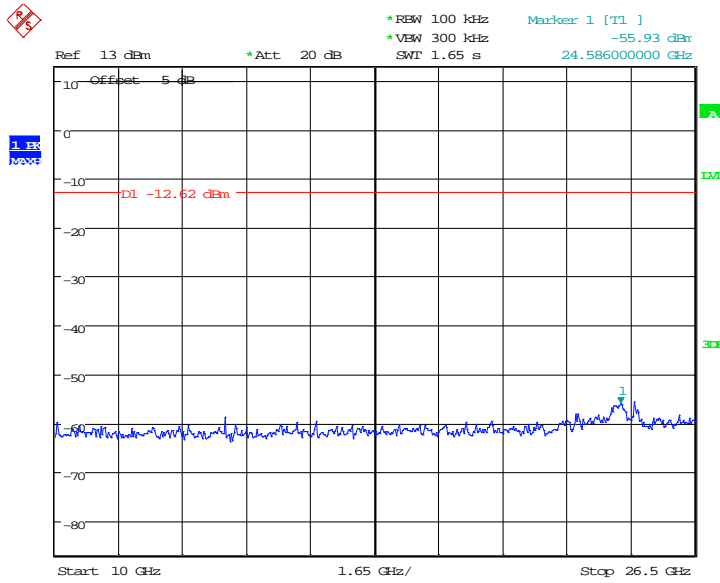

Date: 26.MAY.2016 15:02:11

GFSK CH0 10GHz - 26.5GHz

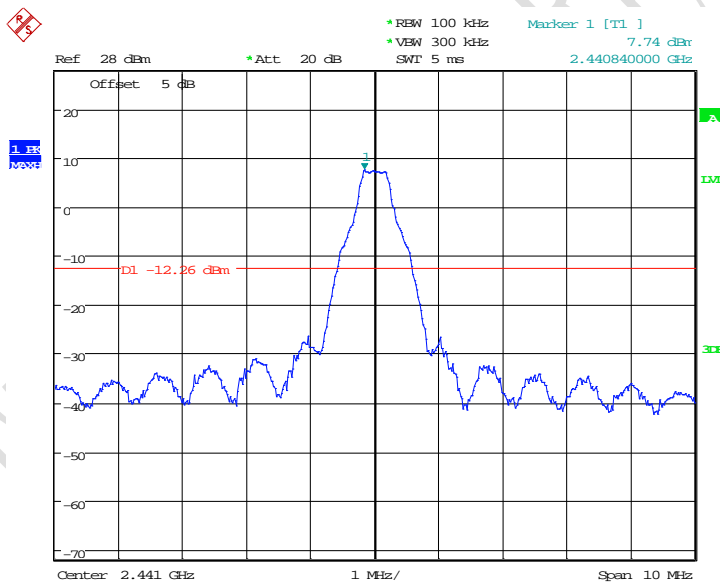

Date: 26.MAY.2016 15:04:20

GFSK CH39 Center Frequency

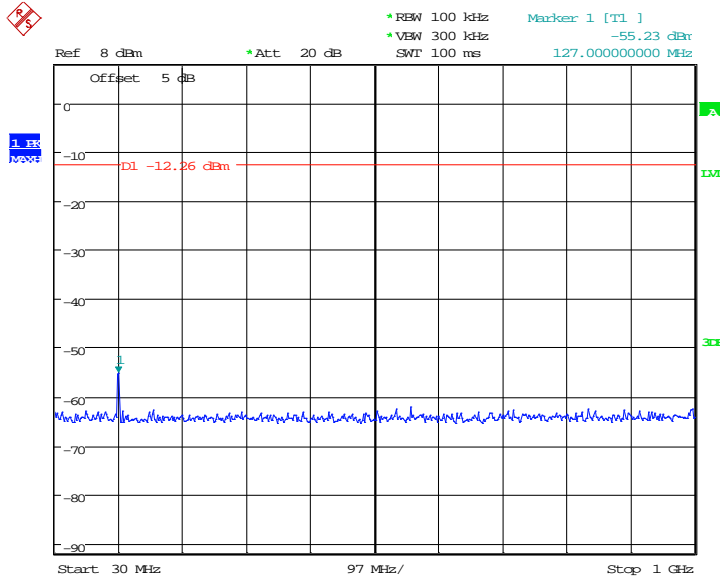

Date: 26.MAY.2016 15:04:56

### GFSK CH39 30MHz - 1GHz

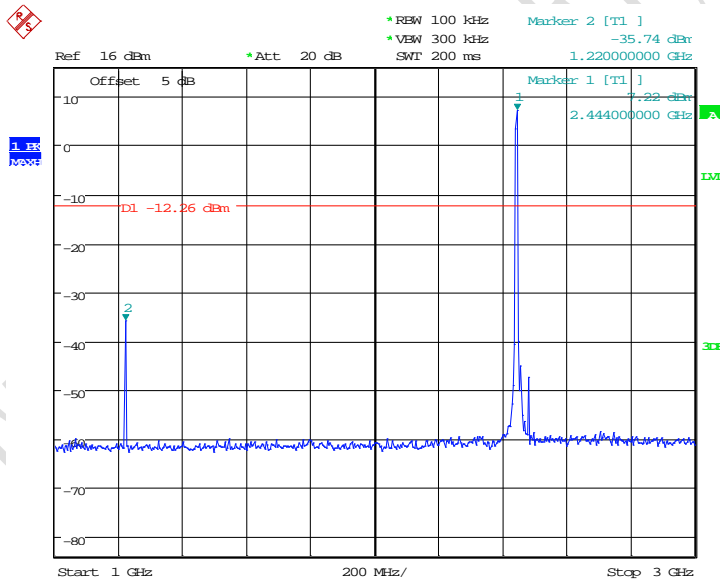

Date: 26.MAY.2016 15:05:26

### GFSK CH39 1GHz - 3GHz

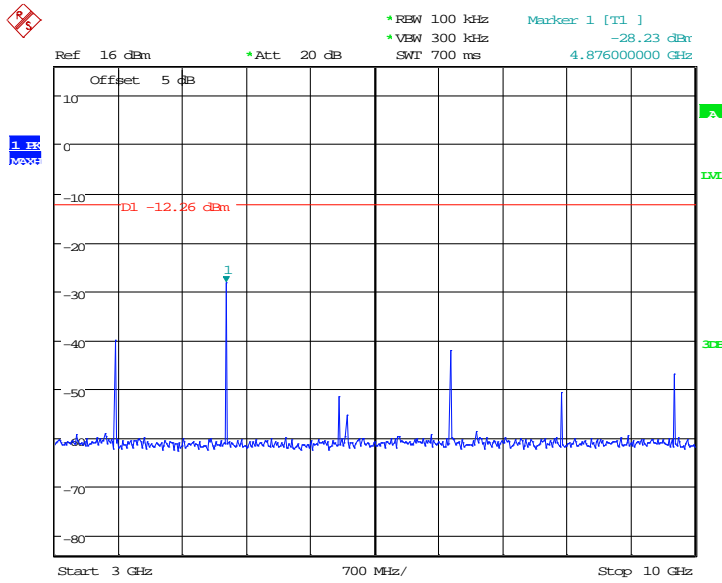

Date: 26.MAY.2016 15:05:50

### GFSK CH39 3GHz – 10GHz

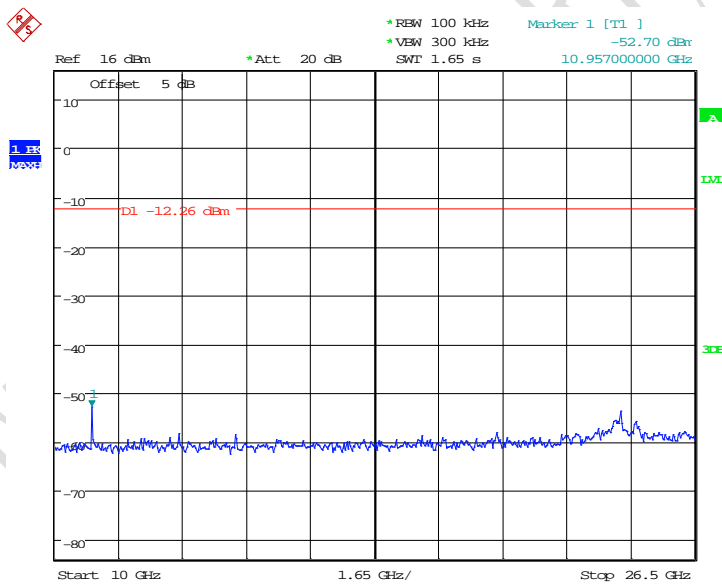

Date: 26.MAY.2016 15:06:13

### GFSK CH39 10GHz – 26.5GHz



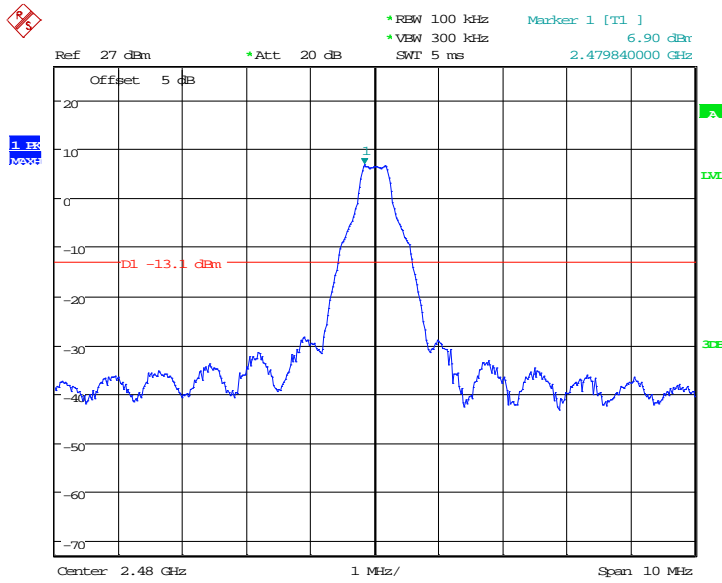

Date: 26.MAY.2016 15:09:37

### GFSK CH78 Center Frequency

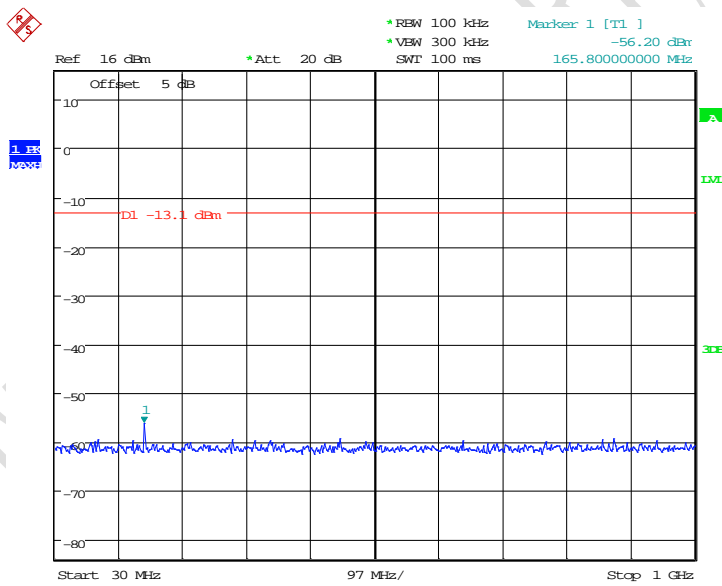

Date: 26.MAY.2016 15:10:21

### GFSK CH78 30MHz - 1GHz

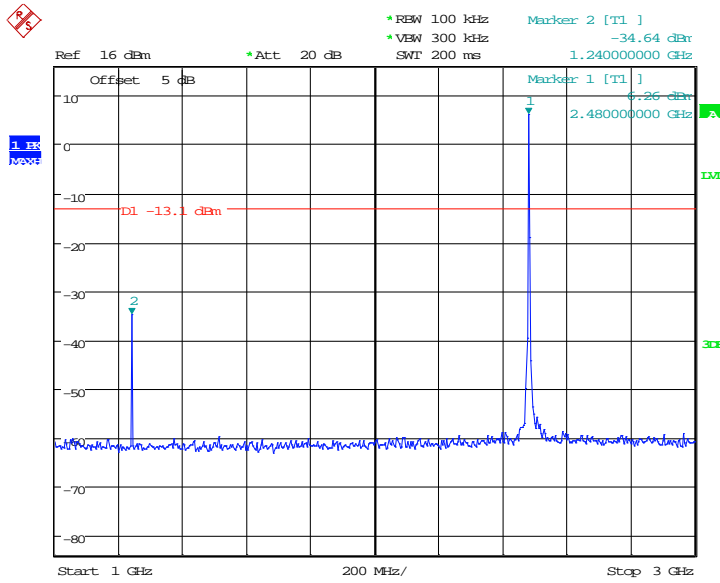

Date: 26.MAY.2016 15:10:36

### GFSK CH78 1GHz - 3GHz

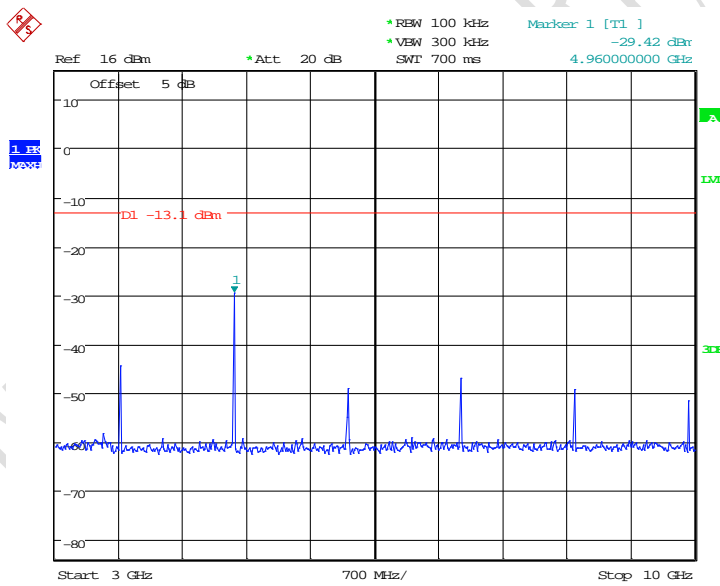

Date: 26.MAY.2016 15:10:54

### GFSK CH78 3GHz - 10GHz

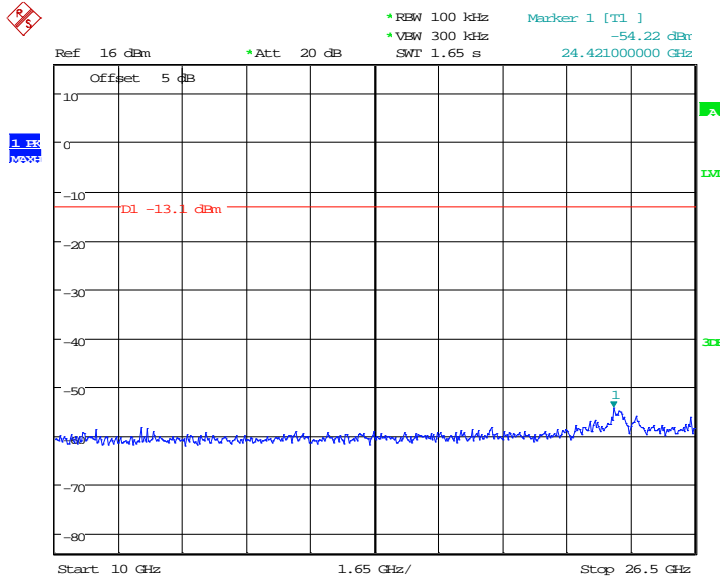

Date: 26.MAY.2016 15:11:20

### GFSK CH78 10GHz – 26.5GHz

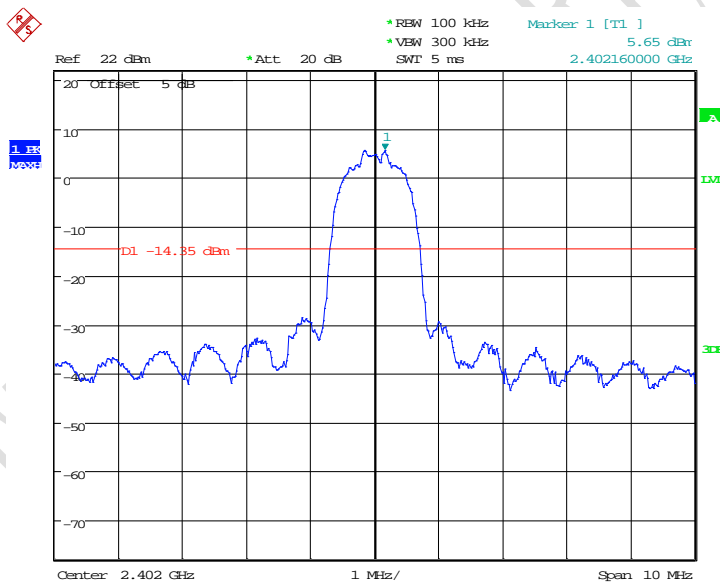

Date: 26.MAY.2016 15:14:13

### PI/4 DQPSK CH0 Center Frequency

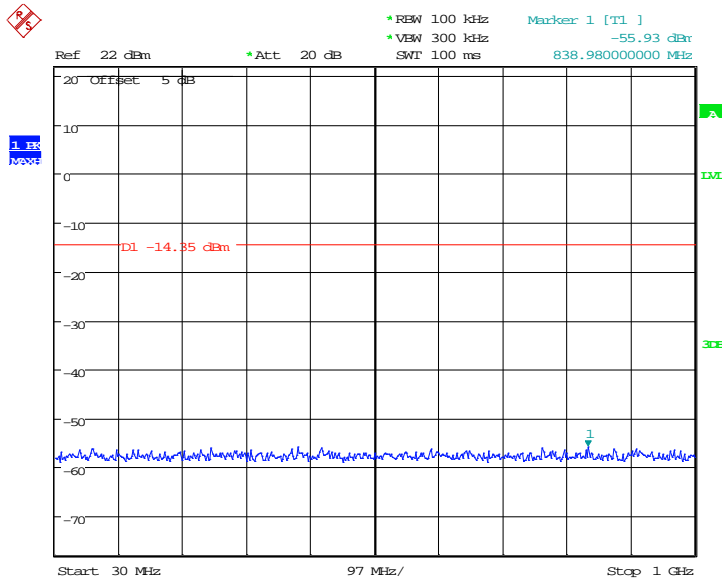

Date: 26.MAY.2016 15:14:41

### PI/4 DQPSK CH0 30MHz - 1GHz

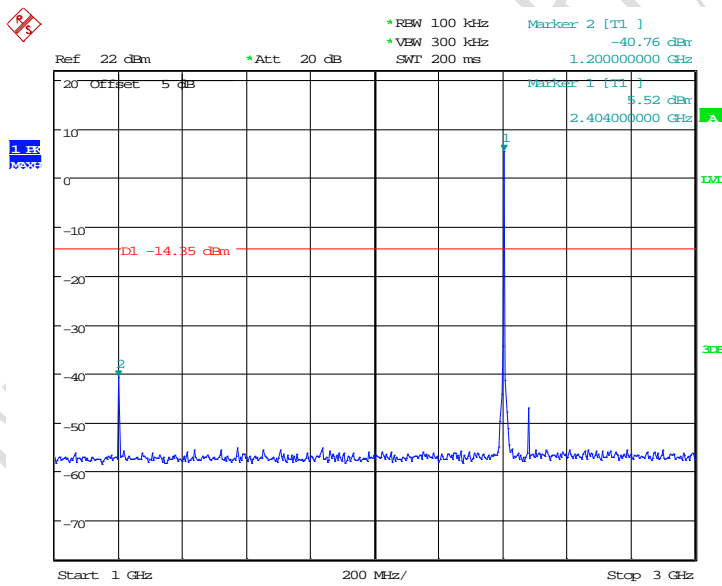

Date: 26.MAY.2016 15:15:03

### PI/4 DQPSK CH0 1GHz - 3GHz

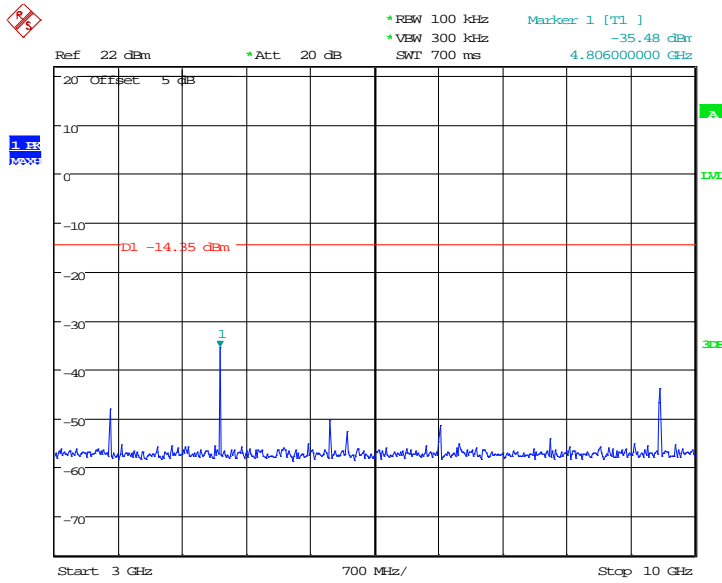

Date: 26.MAY.2016 15:15:23

### PI/4 DQPSK CH0 3GHz - 10GHz

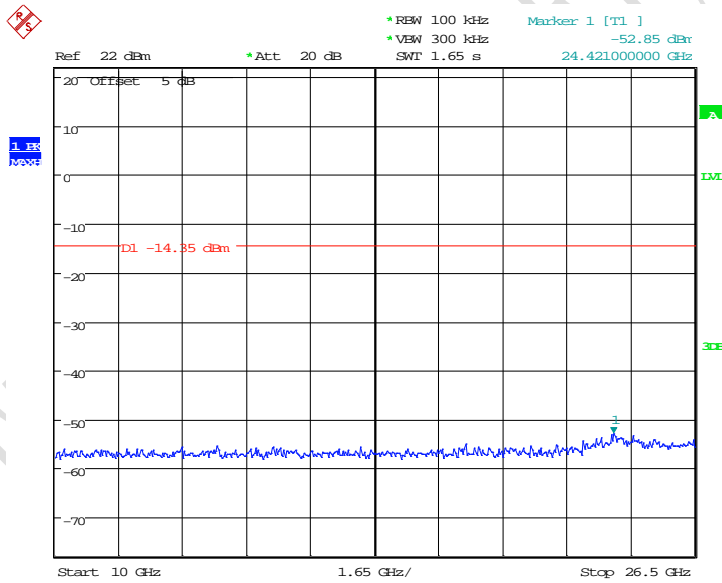

Date: 26.MAY.2016 15:15:51

### PI/4 DQPSK CH0 10GHz - 26.5GHz

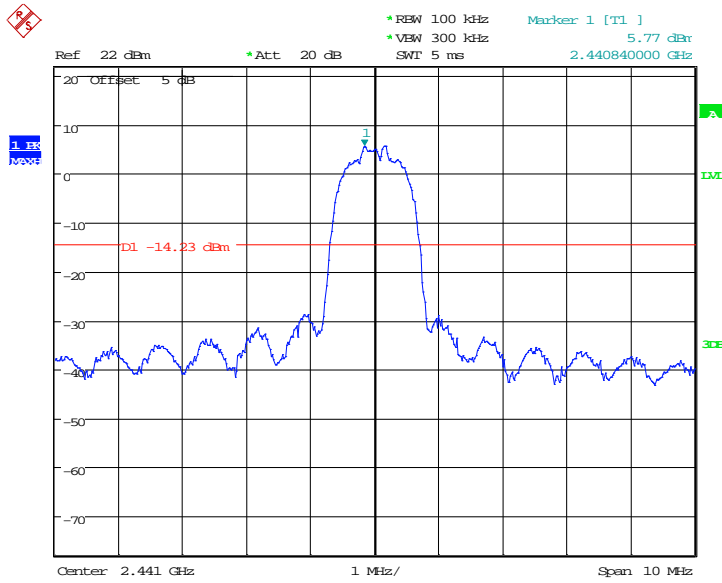

Date: 26.MAY.2016 15:17:40

### PI/4 DQPSK CH39 Center Frequency

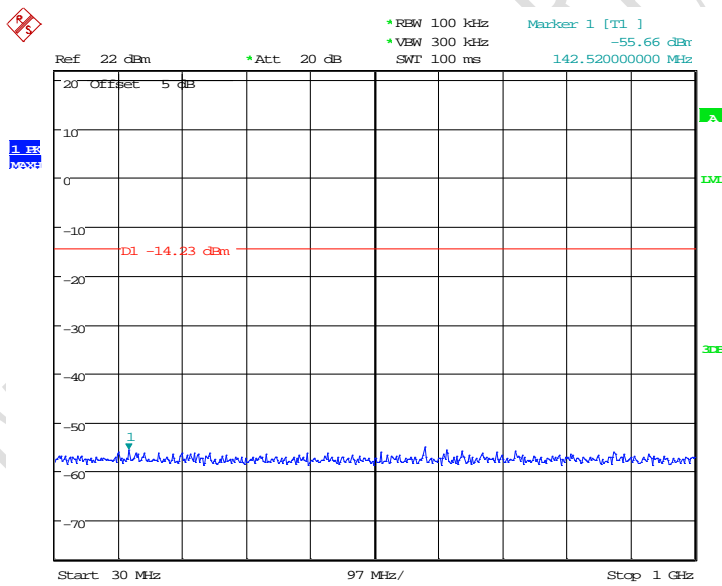

Date: 26.MAY.2016 15:17:58

### PI/4 DQPSK CH39 30MHz - 1GHz

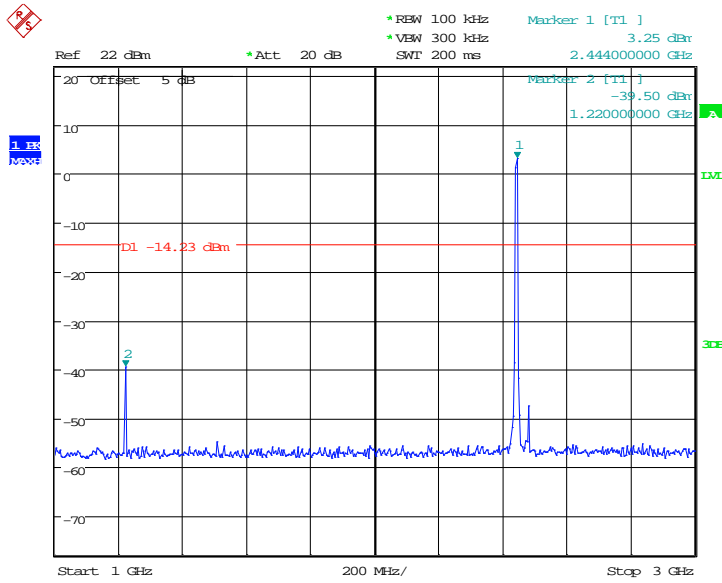

Date: 26.MAY.2016 15:18:28

PI/4 DQPSK CH39 1GHz - 3GHz

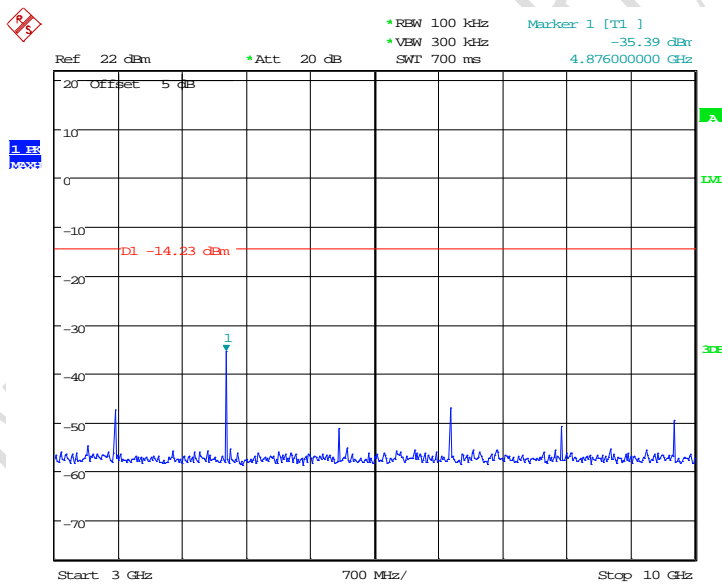

Date: 26.MAY.2016 15:18:43

PI/4 DQPSK CH39 3GHz - 10GHz

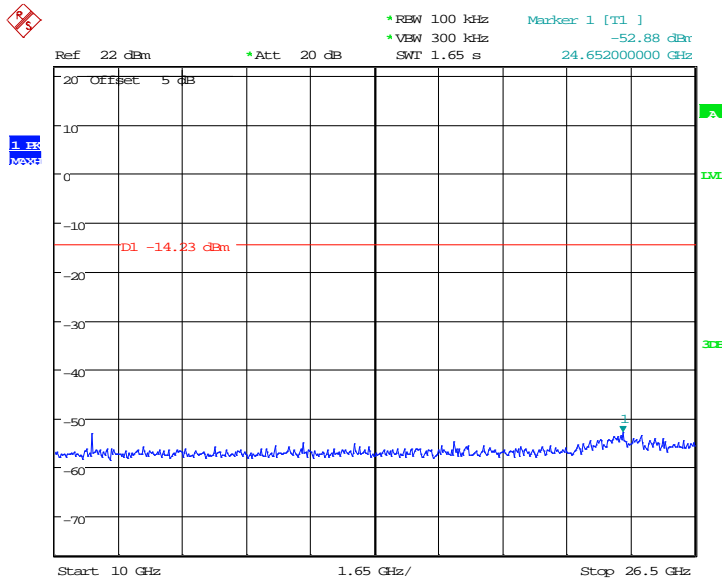

Date: 26.MAY.2016 15:19:02

### PI/4 DQPSK CH39 10GHz - 26.5GHz

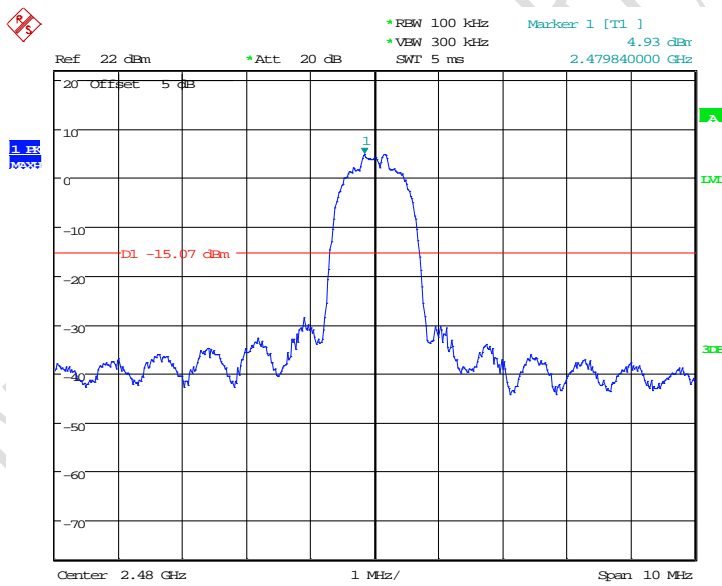

Date: 26.MAY.2016 15:21:12

### PI/4 DQPSK CH78 Center Frequency



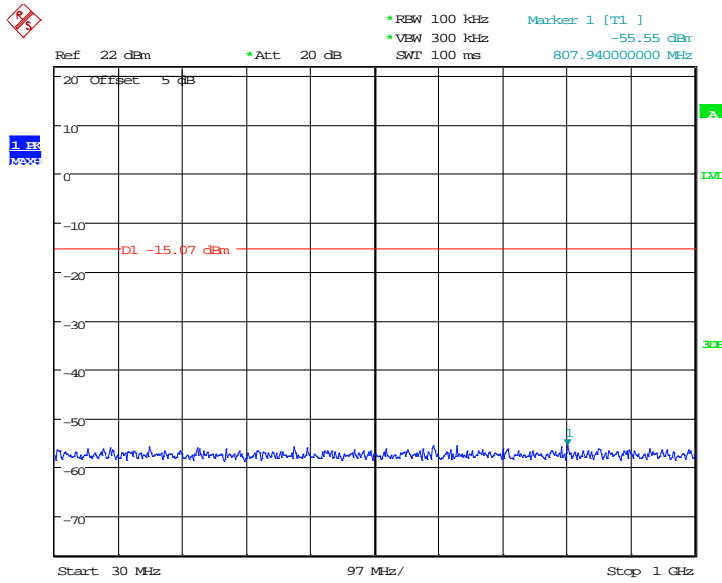

Date: 26.MAY.2016 15:21:40

PI/4 DQPSK CH78 30MHz - 1GHz

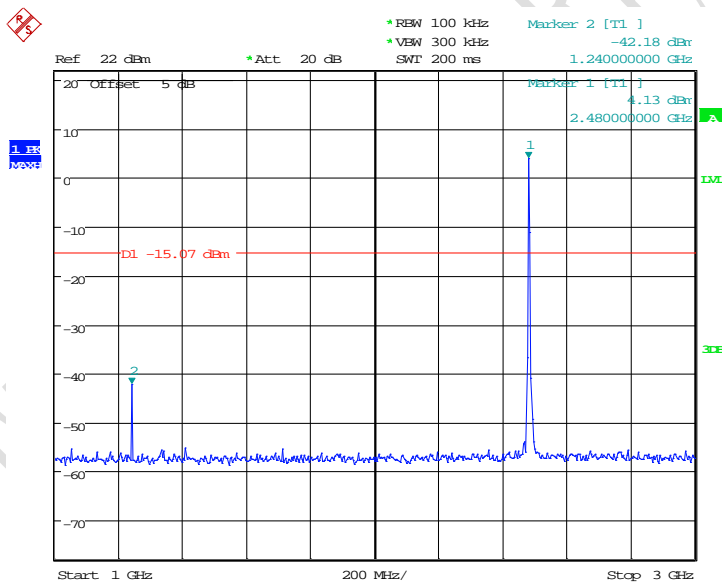

Date: 26.MAY.2016 15:21:59

PI/4 DQPSK CH78 1GHz - 3GHz

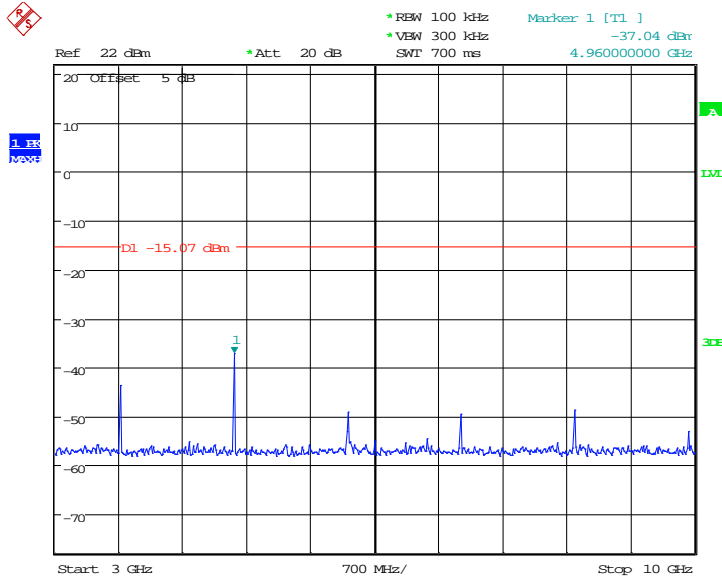

Date: 26.MAY.2016 15:22:29

### PI/4 DQPSK CH78 3GHz - 10GHz

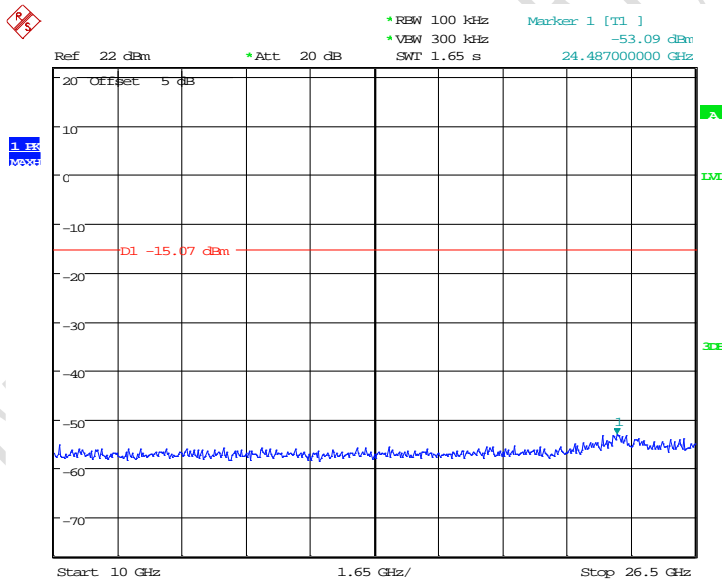

Date: 26.MAY.2016 15:22:52

### PI/4 DQPSK CH78 10GHz - 26.5GHz

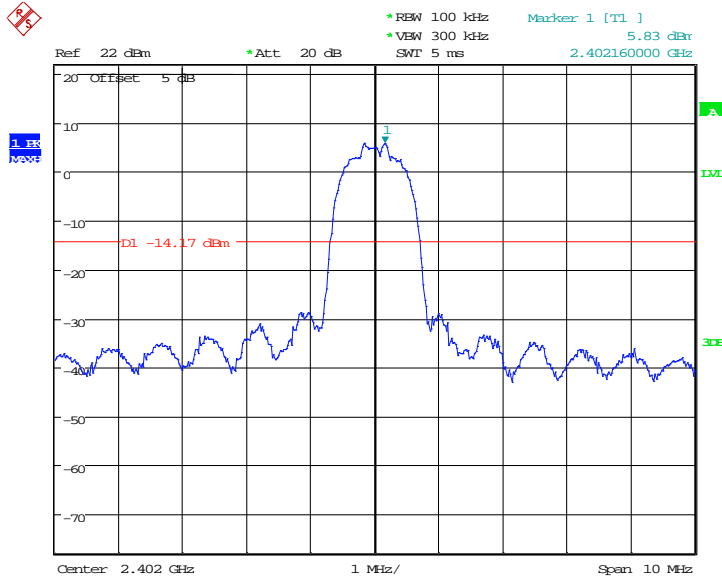

Date: 26.MAY.2016 15:25:09

### 8DPSK CH0 Center Frequency

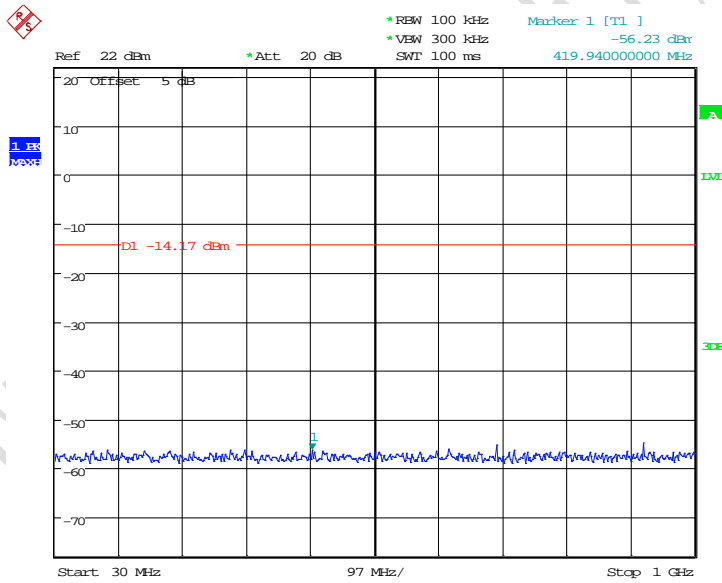

Date: 26.MAY.2016 15:25:48

### 8DPSK CH0 30MHz - 1GHz

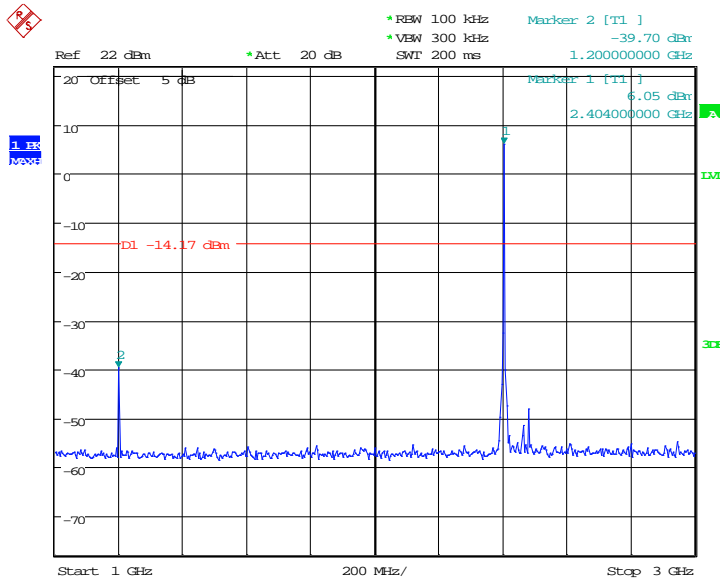

8DPSK CH0 1GHz - 3GHz

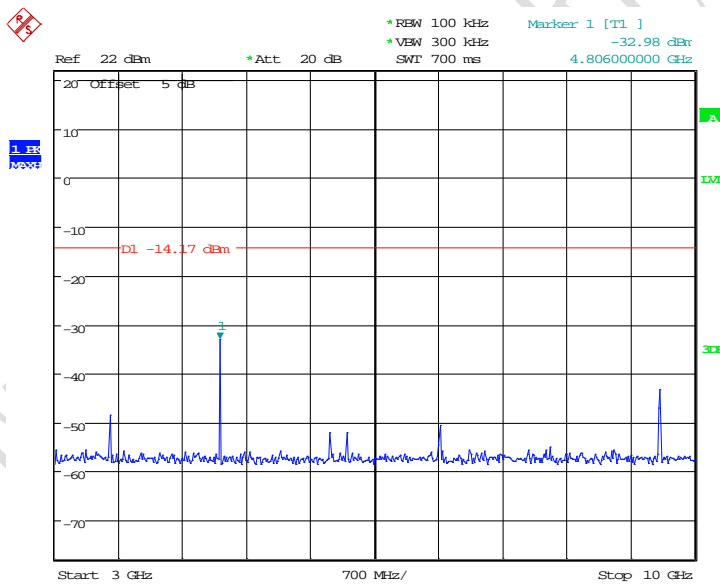

8DPSK CH0 3GHz - 10GHz

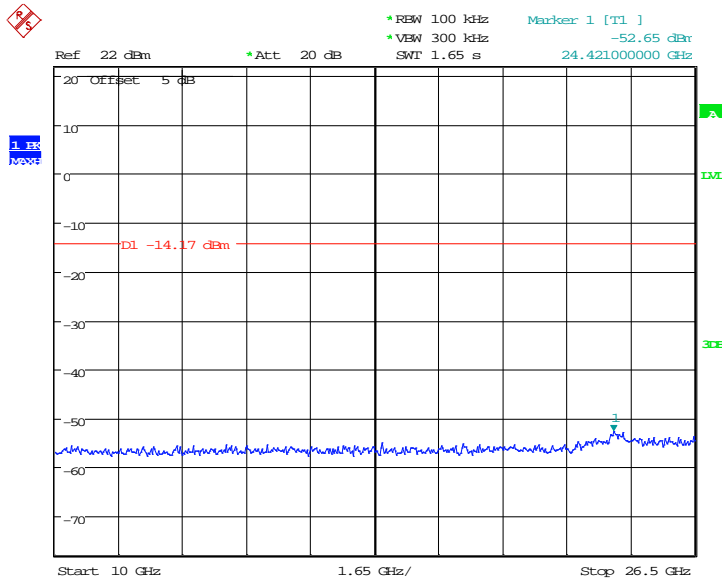

Date: 26.MAY.2016 15:27:21

### 8DPSK CH0 10GHz - 26.5GHz

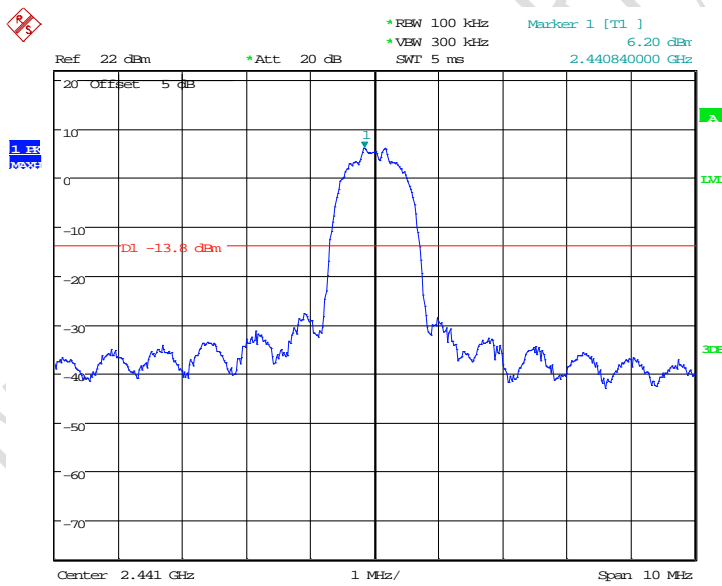

Date: 26.MAY.2016 15:29:10

### 8DPSK CH39 Center Frequency

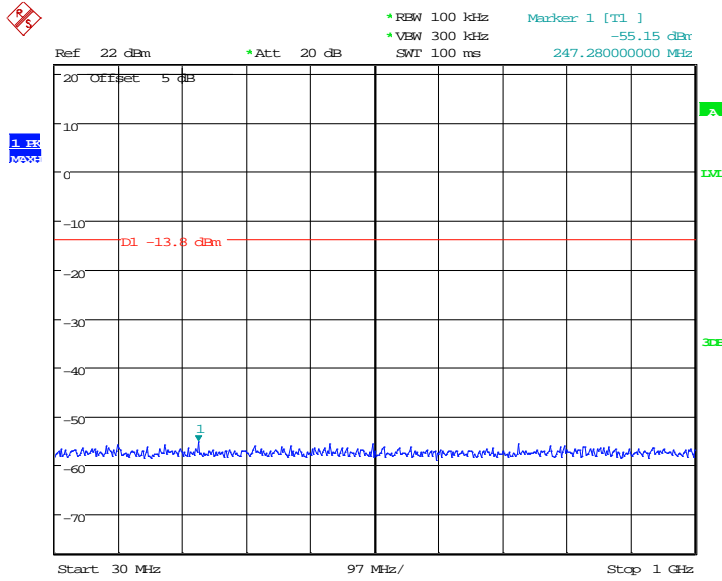

Date: 26.MAY.2016 15:29:36

### 8DPSK CH39 30MHz - 1GHz

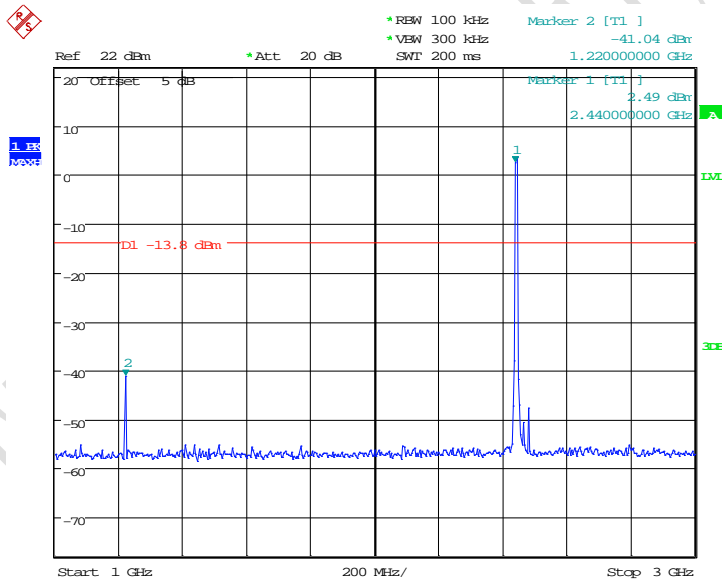

Date: 26.MAY.2016 15:30:08

### 8DPSK CH39 1GHz - 3GHz

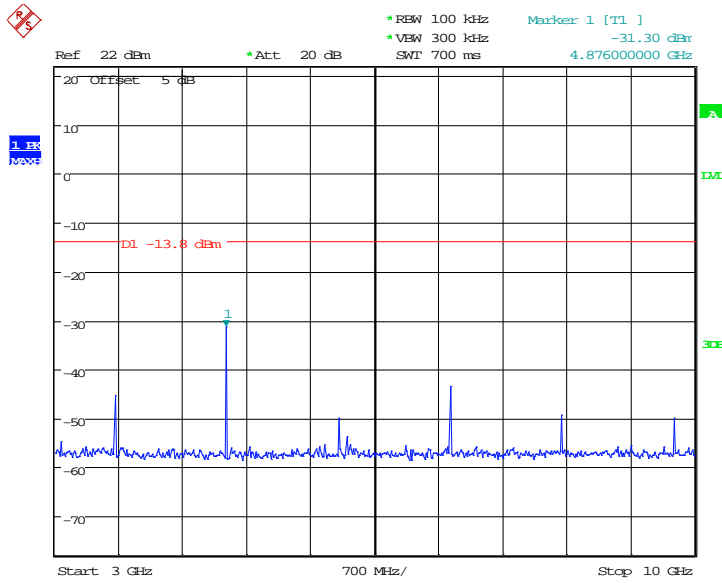

Date: 26.MAY.2016 15:30:31

### 8DPSK CH39 3GHz - 10GHz

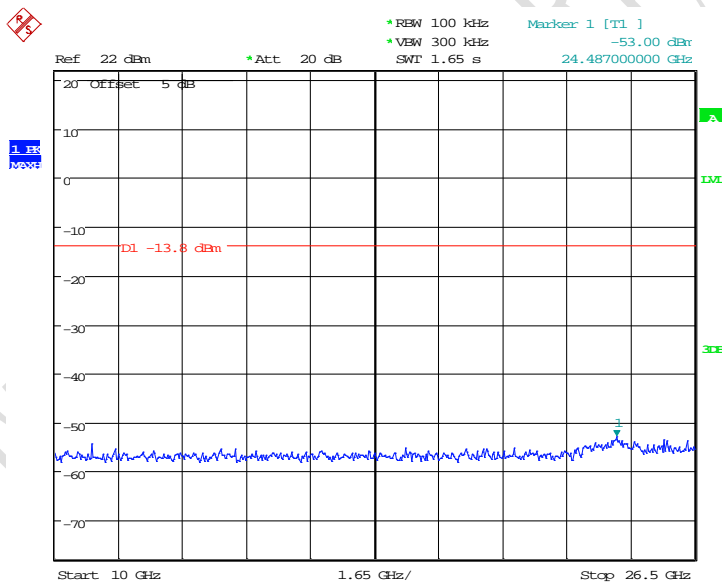

Date: 26.MAY.2016 15:30:59

### 8DPSK CH39 10GHz - 26.5GHz

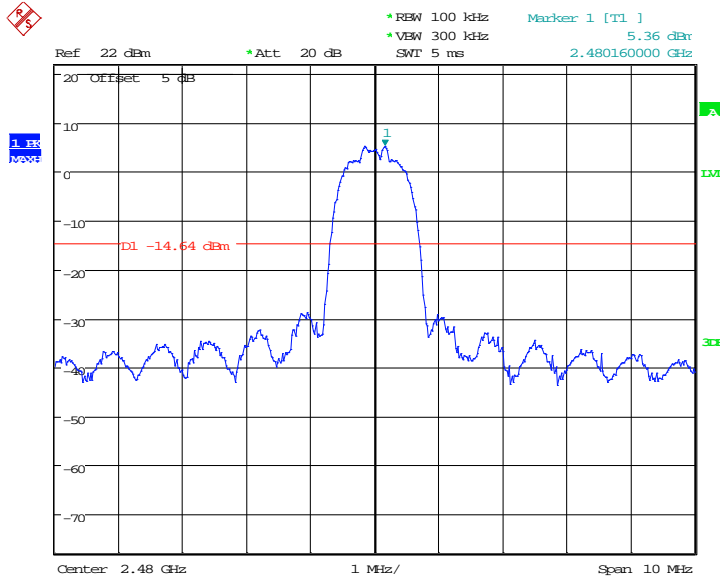

Date: 26.MAY.2016 15:33:53

8DPSK CH78 Center Frequency

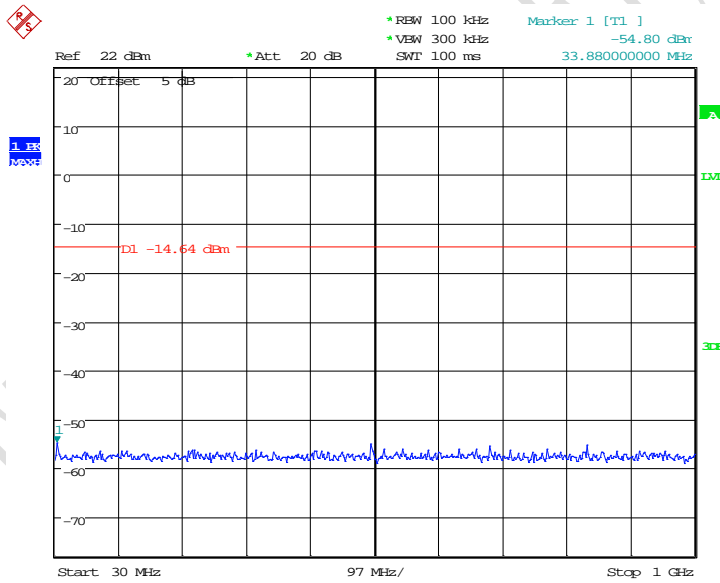

Date: 26.MAY.2016 15:35:28

8DPSK CH78 30MHz – 1GHz



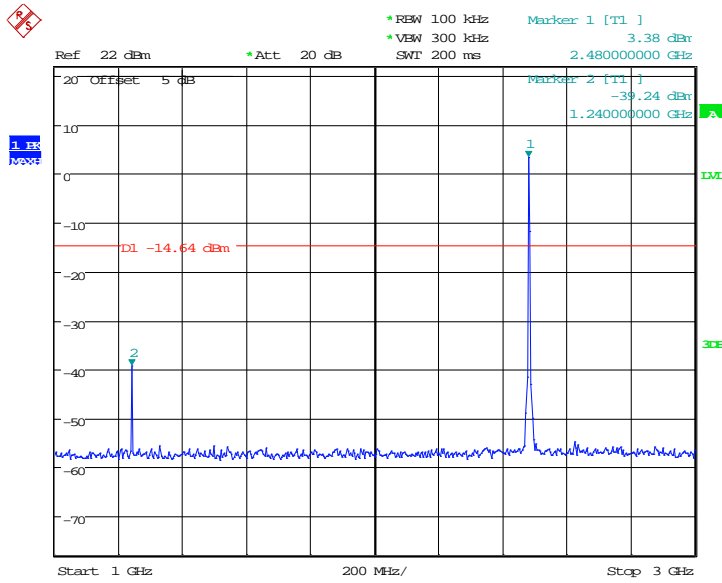

Date: 26.MAY.2016 15:35:49

8DPSK CH78 1GHz - 3GHz

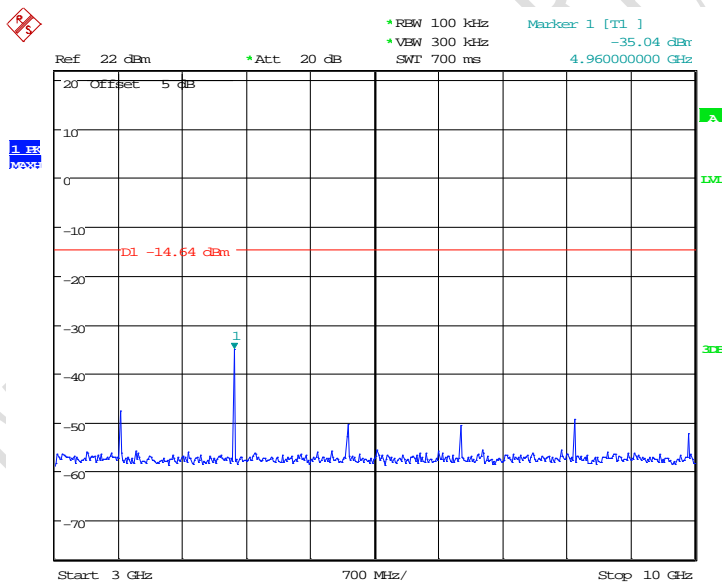

Date: 26.MAY.2016 15:36:04

8DPSK CH78 3GHz - 10GHz

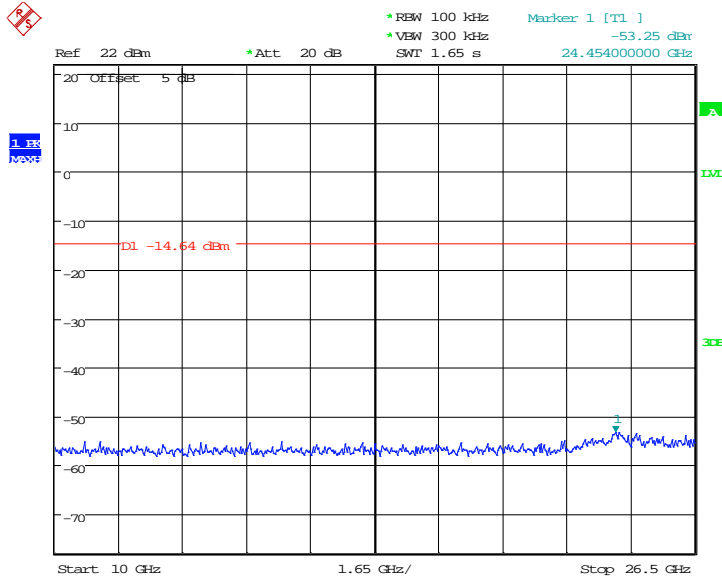

Date: 26.MAY.2016 15:36:27

8DPSK CH78 10GHz - 26.5GHz

**5.7 Ratio Radiated Emission Measurement**

<b>Specifications:</b>	FCC Part 15.209(a) and 15.205(a)
<b>DUT Serial Number:</b>	S1/7: 356307070001879
<b>Test conditions:</b>	Ambient Temperature:15°C-35°C Relative Humidity:30%-60% Air pressure: 86-106kPa
<b>Test Results:</b>	--

**Limit**

1. 20dBc in any 100 kHz bandwidth outside the operating frequency band. In case the emission fall within the restricted band specified on 15.205(a), then the 15.209(a) limit in the table below has to be followed

Frequency (MHz)	Field Strength (uV/m)	Measurement Distance (m)
1.705-30	30	30
30-88	100	3
88-216	150	3
216-960	200	3
Above 960	500	3

**Test Setup**

The EUT was placed in an anechoic chamber. The BLUETOOTH TESTER was used to set the TX channel and power level. The transmitter output is connected to Spectrum analyzer through a Bilog antenna (for frequency 30MHz-1GHz) or a horn antenna (for frequency above 1GHz).  
30MHz-1GHz:

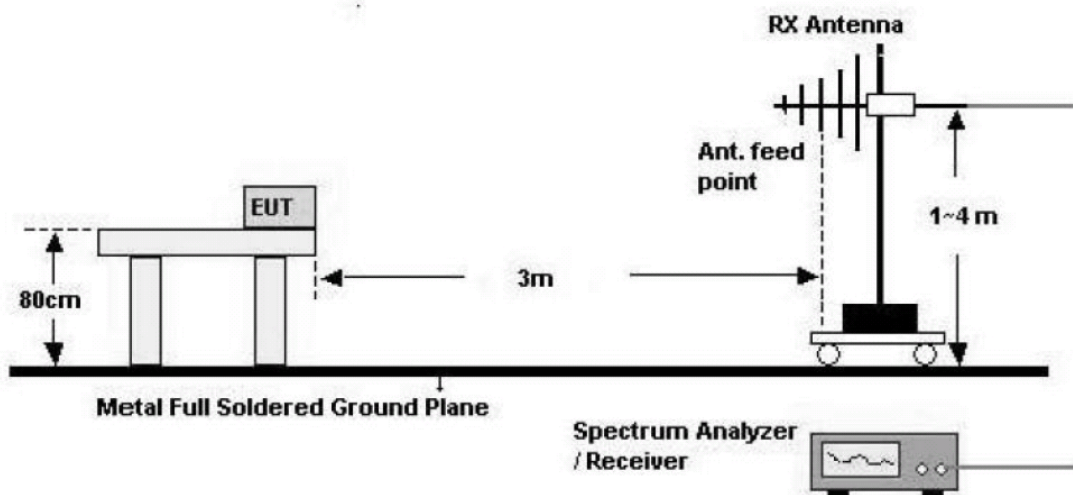

Above 1GHz:

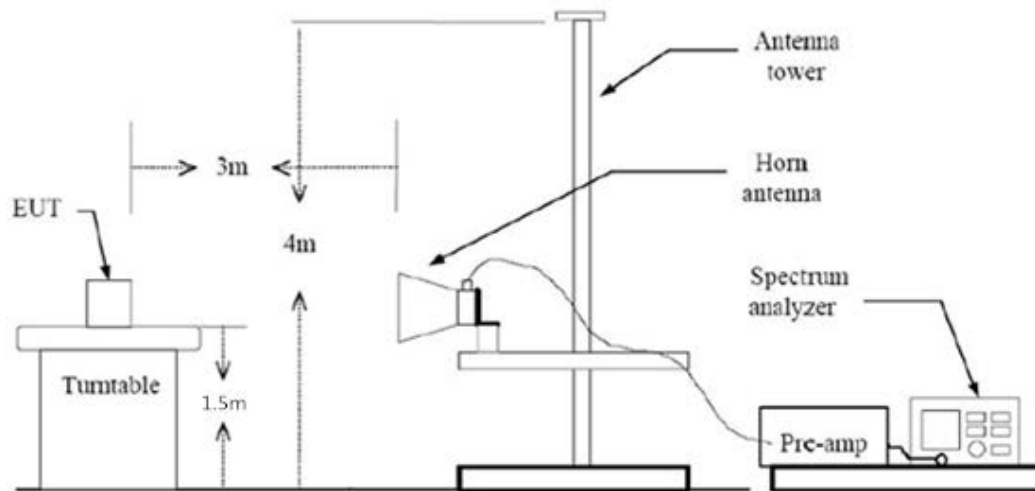

### Test Procedure

1. The EUT is placed on a turntable.
2. The turntable shall be rotated for 360 degrees on EUT's x, y and z axis to determine the position of maximum emission level.
3. EUT is set 3 m away from the receiving antenna, which is varied from 1m to 4m to find out the highest emissions.
4. Maximum procedure was performed on the six highest emissions to ensure EUT compliance.
5. And also, each emission was to be maximized by changing the polarization of receiving antenna both horizontal and vertical.
6. Repeat above procedures until the measurements for all frequencies are complete.

The measurement is made according to Public notice FCC Public Notice DA 00-705, March 2000, and ANSI C63.4-2014.

### Test Settings:

Frequency Range (MHz)	RBW/VBW	Sweep time (s)
30 – 1000	100kHz/300kHz	5
1000 – 4000	1MHz/3MHz	15
4000 – 18000	1MHz/3MHz	40
18000 – 26500	1MHz/3MHz	20

Note: Considering the GFSK modulation with packet type DH5 has the maximum transmission power, so only this mode is tested.

**Test result:**

Channel	Frequency Range	Results
Channel 0	30MHz – 1GHz	Pass
	1 GHz – 3GHz	Pass
	2.38GHz-2.45GHz*	Pass
	3 GHz – 18 GHz	Pass
Channel 39	30MHz – 1GHz	Pass
	1 GHz – 3GHz	Pass
	2.4GHz-2.48GHz*	Pass
	3 GHz – 18 GHz	Pass
Channel 78	30MHz – 1GHz	Pass
	1 GHz – 3GHz	Pass
	2.45GHz-2.5GHz*	Pass
	3 GHz – 18 GHz	Pass
All channels	18GHz-26.5GHz	Pass

Note\*: these tests demonstrate the radiated band-edge test results

**Notes:**

1. Radiated emissions were measured with an instrument using Quasi-peak detector mode in frequency range from 30 MHz to 1000MHz, and with peak detector mode in frequency range from 1GHz – 26.5 GHz.
- 2 Total dBuV/m = Reading dBuV/m – Cable Loss dB + Antenna Gain dB.

Test Plots:

RE 30MHz-1GHz

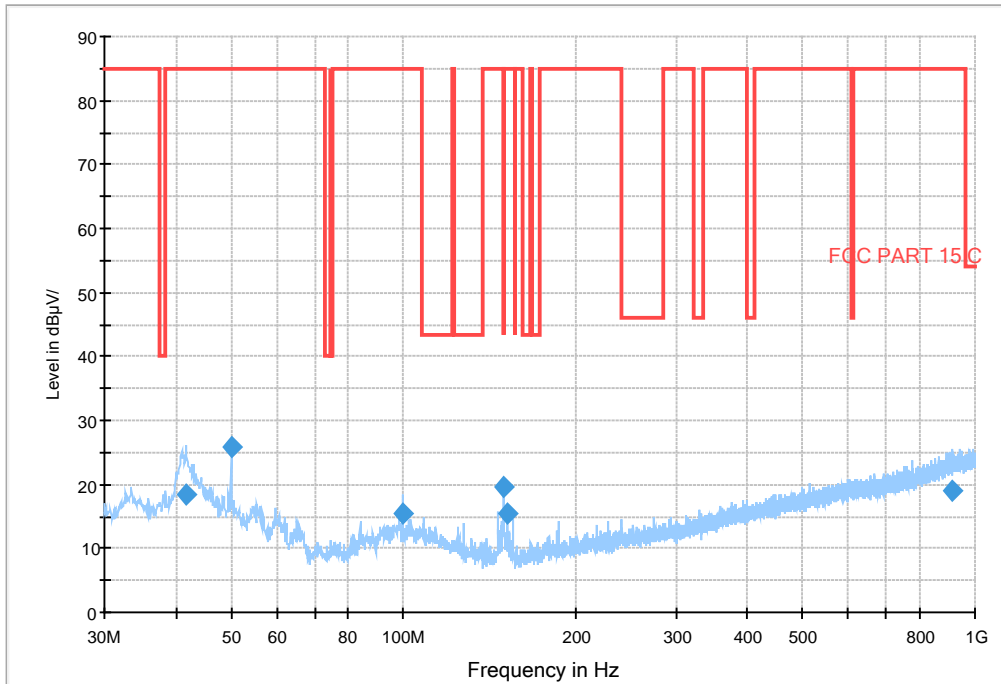

GFSK DH5 Channel 0 30MHz-1GHz

RE 1GHz-3GHz

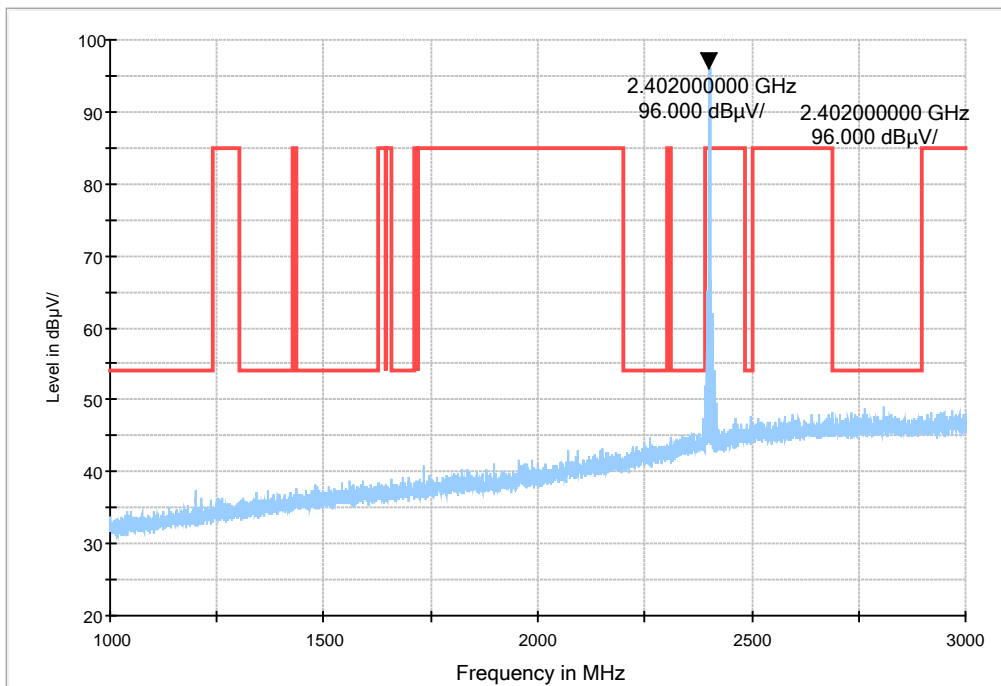

GFSK DH5 Channel 0 1-3GHz

RE 3GHz-18GHz

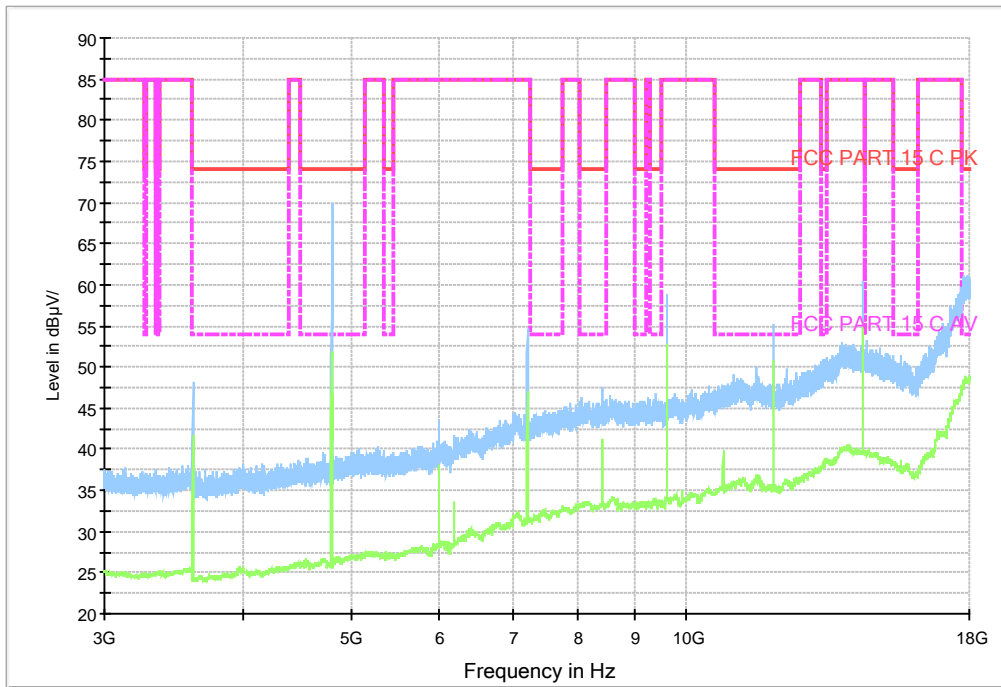

GFSK DH5 Channel 0 3G-18GHz

RE 30MHz-1GHz

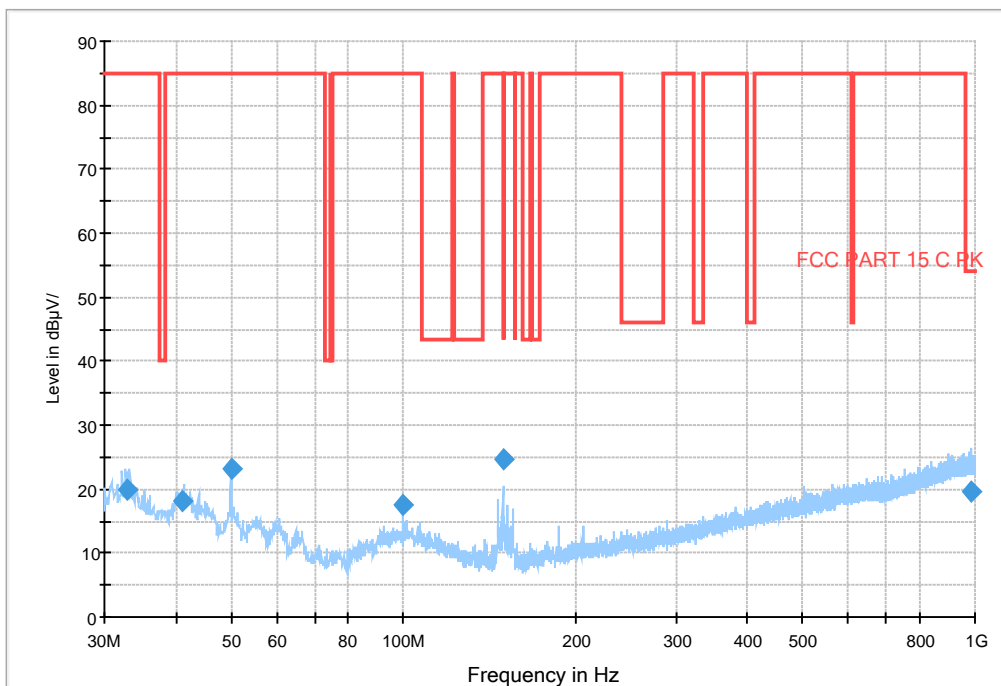

GFSK DH5 Channel 39 30MHz-1GHz

RE 1GHz-3GHz

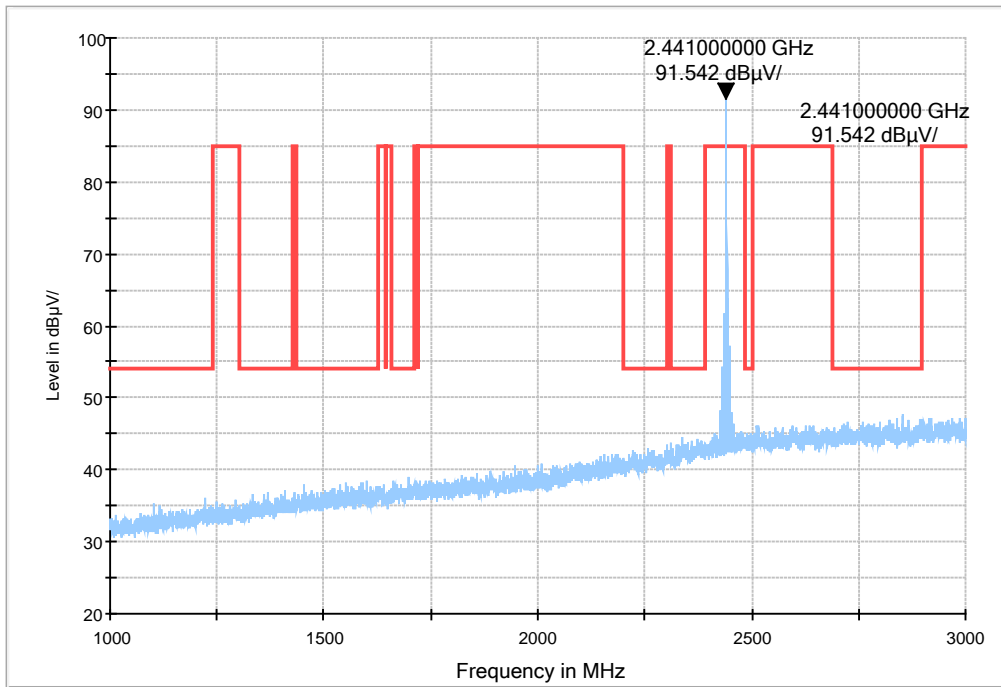

GFSK DH5 Channel 39 1-3GHz

RE 3GHz-18GHz

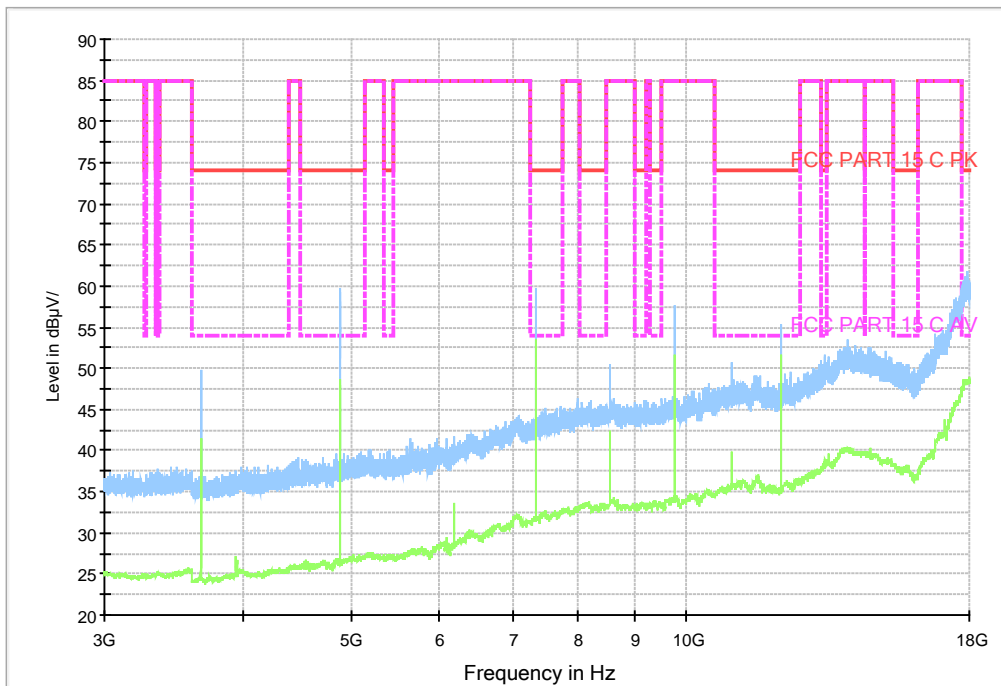

GFSK DH5 Channel 39 3-18GHz



RE 30MHz-1GHz

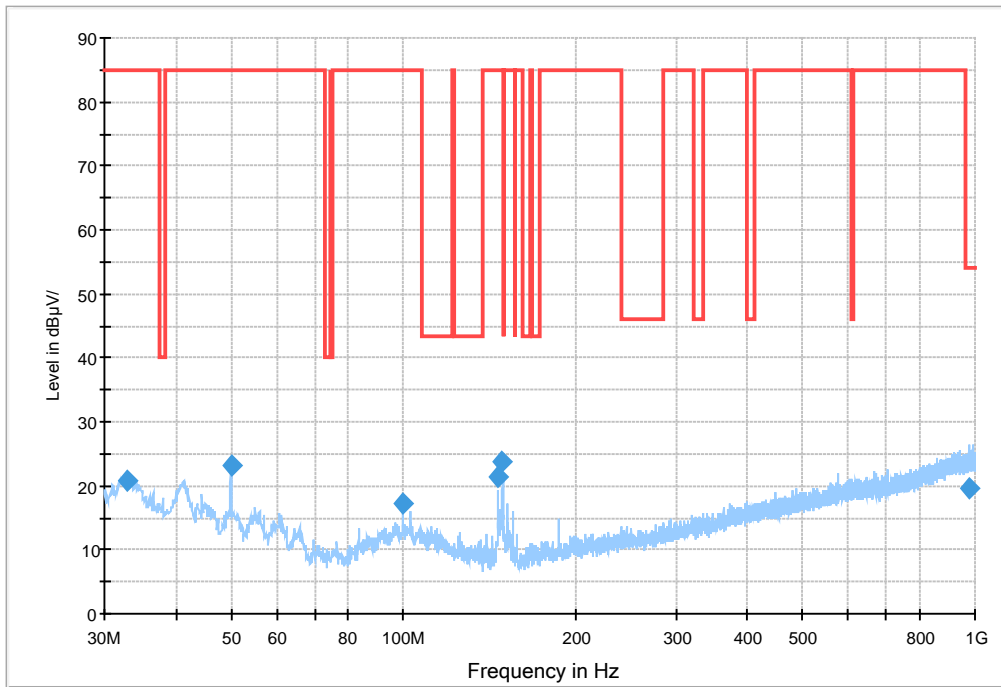

GFSK DH5 Channel 78 30MHz-1GHz

RE 1GHz-3GHz

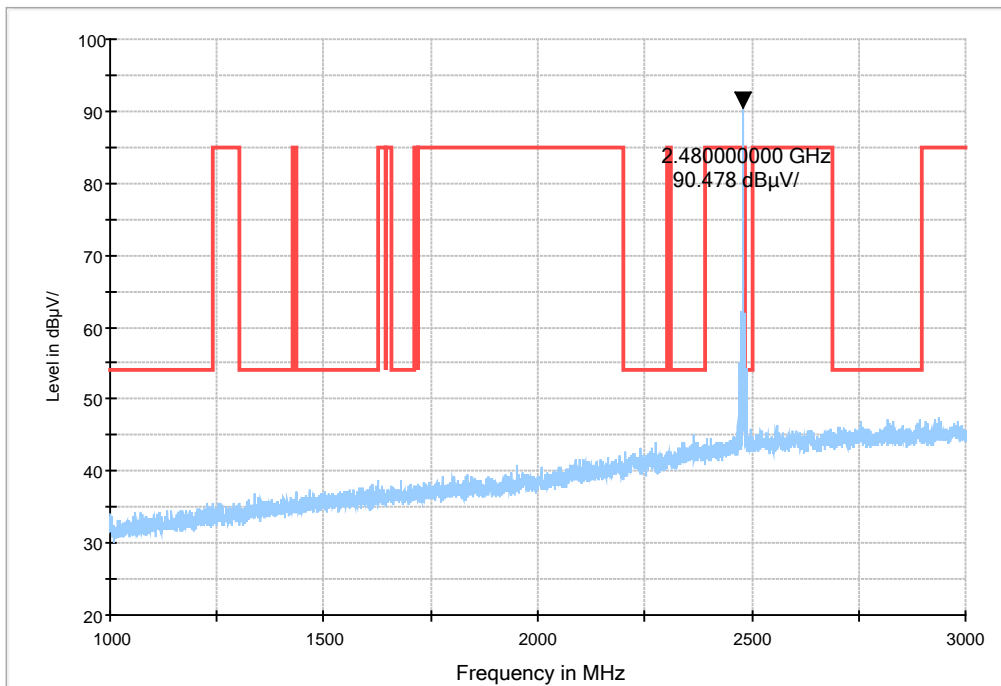

GFSK DH5 Channel 78 1-3GHz

RE 3GHz-18GHz

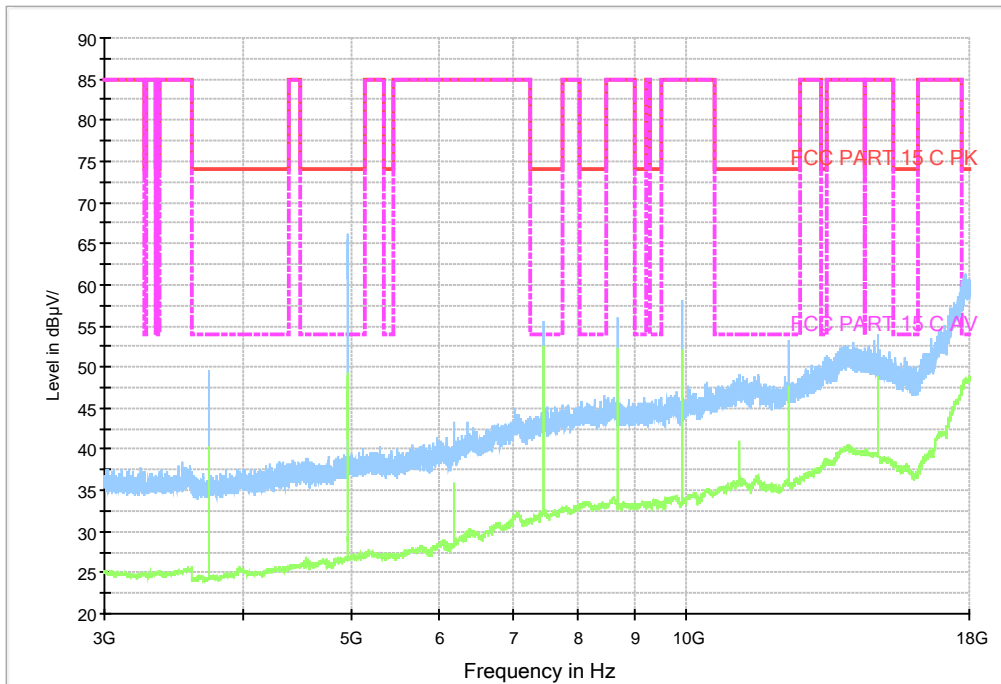

GFSK DH5 Channel 39 3-18GHz

Copy (2) of FCC Part15C 18-26G

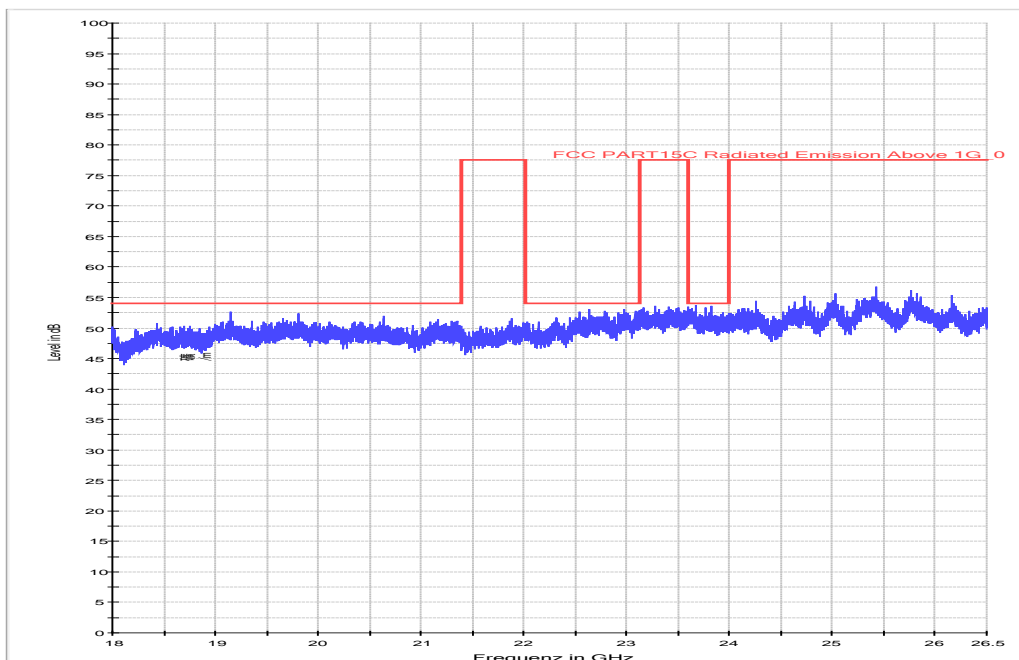

GFSK DH5 all channels

Test photo

See the Pic1- Pic6 in document "U200 -BT Test Setup Photos".

**5.8 Power line Conducted Emissions**

<b>Specifications:</b>	ANSI C63.4 voltage mains test
<b>DUT Serial Number:</b>	S1/7: 356307070001879
<b>Test conditions:</b>	Ambient Temperature:15°C-35°C Relative Humidity:30%-60% Air pressure: 86-106kPa
<b>Test Results:</b>	--

**Limit**

The EUT meets the requirement of having a peak to average ratio of less than 13dB.  
For an intentional radiator which is designed to be connected to the public utility (AC) power line, the radio frequency voltage that is conducted back onto the AC power line on any frequency or frequencies within the band 150 kHz to 30 MHz shall not exceed 250 microvolt (The limit decreases linearly with the logarithm of the frequency in the range 0.15 MHz to 0.50 MHz). The limits at specific frequency range are listed as follows:

**Limits of the conducted disturbance at the AC mains ports:**

Frequency range	Limit(Quasi-peak)	Limit(Average)
0.15 MHz to 0.5 MHz	66 dBμV – 56 dBμV	56 dBμV – 46 dBμV
>0.5 MHz to 5MHz	56 dBμV	46 dBμV
>5 MHz to 30 MHz	60 dBμV	50 dBμV

NOTE: The limit decreases linearly with the logarithm of the frequency in the range 0.15 MHz to 0.50 MHz.

Compliance with this provision shall be based on the measurement of the radio frequency voltage between each power line (LINE and NEUTRAL) and ground at the power terminals.

**Test Setup**

The EUT was placed in a shielding room. The BLUETOOTH TESTER was used to set the TX channel and power level. The ac adapter output is connected to Receiver through an AMN (Artificial Mains Network).

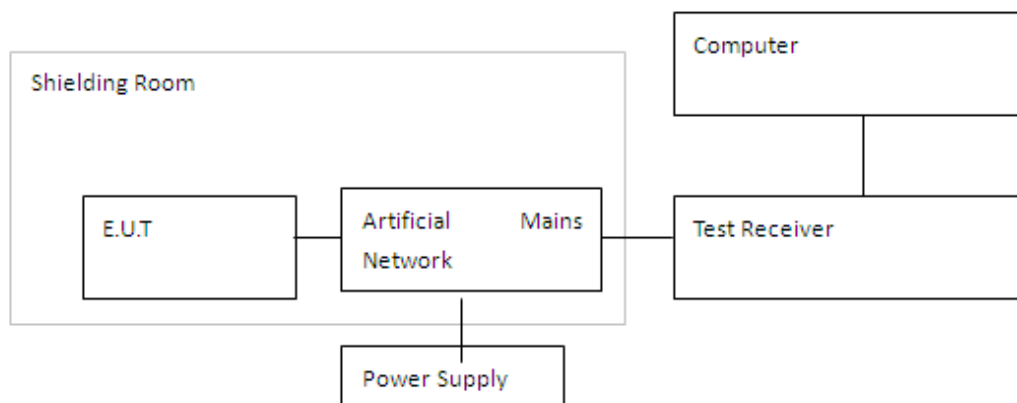

**Test Procedure**

1. The EUT is placed on a wooden table 80 cm above the reference ground plane.
2. The EUT is connected via LISN to a test power supply.
3. The measurement results are obtained as described below:
4. Detectors – Quasi Peak and Average Detector.

The measurement is made according to Public notice FCC Public Notice DA 00-705, March 2000, and ANSI C63.4-2014.

**Test Result:**

Line L&N					
Detector (QP)	Frequency (MHz)	Level (dBµV)	Limit (dBµV)	Line	PE
QP	0.500350	43.7	56.0	L1	FLO
QP	0.542406	19.4	56.0	N	FLO
QP	0.788731	23.3	56.0	L1	FLO
QP	1.389225	20.9	56.0	N	FLO
QP	2.937331	35.3	56.0	L1	FLO
QP	3.430662	30.4	56.0	L1	FLO

Line L&N					
Detector (AV)	Frequency (MHz)	Level (dBµV)	Limit (dBµV)	Line	PE
AV	0.508350	7.4	46.0	L1	FLO
AV	0.796731	15.1	46.0	N	FLO
AV	1.371281	5.4	46.0	N	FLO
AV	1.870288	5.6	46.0	L1	FLO
AV	3.081331	5.3	46.0	L1	FLO
AV	3.566662	6.2	46.0	L1	FLO

**Conclusion: PASS**

CISPR N&L1 Voltage 150k to 30MHz-Class B

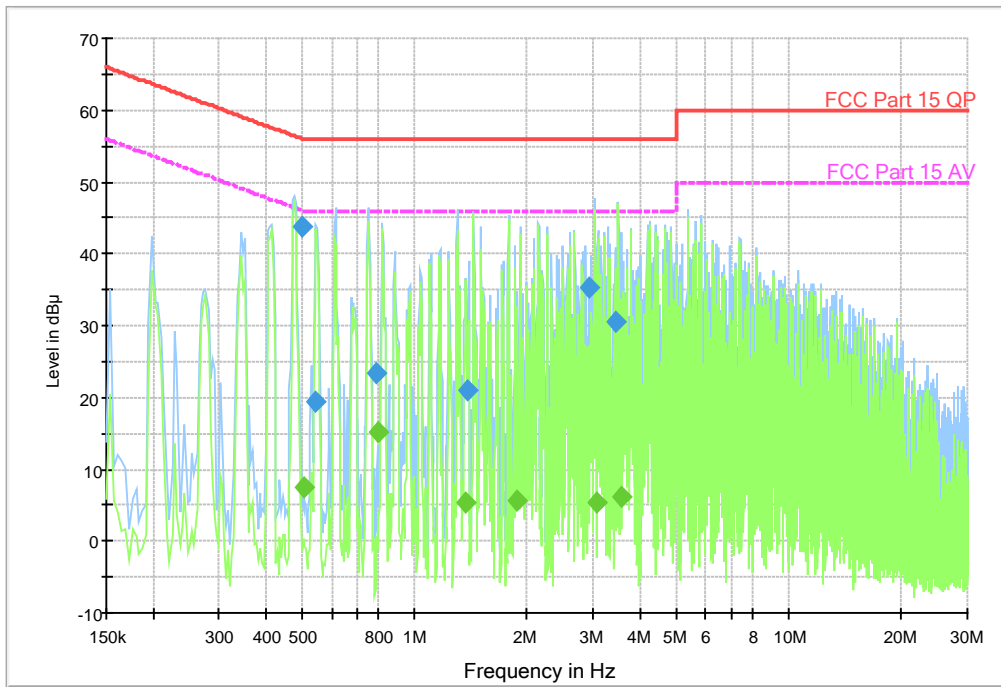

Line L & Line N

**Test photo**

See the Pic7 in document "U200-BT Test Setup Photos".

## **Annex A EUT Photos**

See the document "U200-External Photos".

See the document "U200-Internal Photos".

*CTL Test Report*

Report No.: B16X50179-BT\_Rev1

## ANNEX B Deviations from Prescribed Test Methods

No deviation from Prescribed Test Methods.

\*\*\*End Of Report\*\*\*

*China Test Report*