

TEST REPORT

REPORT NUMBER: B15X50225-FCC-BT

ON

Type of Equipment: Mobile Phone
Type of Designation: U100
Manufacturer: Shenzhen fortuneship technology.,LTD

ACCORDING TO

FCC Part 15, Subpart C, 2015:

15.205 Restricted bands of operation,
15.209 Radiated emission limits; general requirements,
15.247 Operation within the bands 902–928 MHz, 2400–2483.5 MHz,
and 5725–5850 MHz

ANSI C63.4-2014, Methods of Measurement of Radio-Noise Emissions from Low-Voltage Electrical and Electronic Equipment in the Range of 9 kHz to 40 GHz

ANSI C63.10-2013: American National Standard of Procedures for Compliance Testing of Unlicensed Wireless Devices

FCC Public Notice DA 00-705, March-2000, Filing and Measurement Guidelines for Frequency Hopping Spread Spectrum Systems

China Telecommunication Technology Labs.

Month date, year

Jun 17, 2015

Signature



He Guili

Director

FCC ID: ZC4U100
Report Date: 2015-06-17

Test Firm Name: China Telecommunication Technology Labs
Registration Number: 840587

Statement

The measurements shown in this report were made in accordance with the procedures described on test pages. All reported tests were carried out on a sample equipment to demonstrate limited compliance with FCC Parts 15, subpart C. The sample tested was found to comply with the requirements defined in the applied rules.

CONTENTS

1 GENERAL INFORMATION.....	4
1.1 NOTES.....	4
1.2 TESTERS.....	5
1.3 TESTING LABORATORY INFORMATION.....	6
1.4 DETAILS OF APPLICANT OR MANUFACTURER.....	7
2 TEST ITEM.....	8
2.1 GENERAL INFORMATION.....	8
2.2 OUTLINE OF EUT.....	8
2.3 MODIFICATIONS INCORPORATED IN EUT.....	8
2.4 EQUIPMENT CONFIGURATION.....	8
2.5 OTHER INFORMATION.....	8
3 SUMMARY OF TEST RESULTS.....	9
4 TEST RESULTS.....	10
4.1 PEAK POWER.....	10
4.2 BAND EDGES.....	17
4.3 FREQUENCY SEPARATION.....	22
4.4 NUMBER OF HOPPING FREQUENCY.....	30
4.5 TIME OF OCCUPANCY.....	34
4.6 SPURIOUS MEASUREMENT (CONDUCTED).....	41
4.7 RADIATED EMISSION MEASUREMENT.....	67
4.8 POWER LINE CONDUCTED EMISSIONS.....	76
ANNEX A EXTERNAL PHOTOS.....	79
ANNEX B INTERNAL PHOTOS.....	79
ANNEX C DEVIATIONS FROM PRESCRIBED TEST METHODS.....	79

1 General Information

1.1 Notes

All reported tests were carried out on a sample equipment to demonstrate limited compliance with FCC Parts 15, subpart C and ANSI C63.4-2014 and FCC DA 00-705.

The test results of this test report relate exclusively to the item(s) tested as specified in section 2.

The following deviation from, additions to, or exclusions from the test specifications have been made. See Annex C.

China Telecommunication Technology Labs.(CTTL) authorizes the applicant or manufacturer (see section 1.4) to reproduce this report provided, and the test report may only be reproduced or published in full. Reproduction or publication of extracts from the report requires the prior written approval of director of CTTL Mr. He Guili.

Any use which a third party makes of this report, or any reliance on or decisions to be made based on it, are the responsibility of such third parties. CTTL accepts no responsibility for damages, if any, suffered by any third party as a result of decisions made or actions based on this report.

1.2 Testers

Name: Li Guoqing
Position: Engineer
Department: Department of EMC test
Date: 2015-06-17
Signature: 李国庆

Editor of this test report:

Name: Li Guoqing
Position: Engineer
Department: Department of EMC test
Date: 2015-06-17
Signature: 李国庆

Technical responsibility for area of testing:

Name: Zou Dongyi
Position: Manager
Department: Department of EMC test
Date: 2015-06-17
Signature: 邹东屹

1.3 Testing Laboratory information

1.3.1 Location

Name: China Telecommunication Technology Labs.
Address: No. 11, Yue Tan Nan Jie, Xi Cheng District
BEIJING
P. R. CHINA, 100083
Tel: +86 10 68094053
Fax: +86 10 68011404
Email: emc@chinattl.com

1.3.2 Details of accreditation status

Accredited by: China National Accreditation Service for Conformity
Assessment (CNAS)
Registration number: CNAL Registration No.L0570
Standard: ISO/IEC 17025:2005

1.3.3 Test location, where different from section 1.3.1

Name: -----
Street: -----
City: -----
Country: -----
Telephone: -----
Fax: -----
Postcode: -----

1.4 Details of applicant or manufacturer

1.4.1 Applicant

Name: Corporativo Lanix S.A. de C.V.
Address: Carrtera internacional Hermosillo-Nogale Km 8.5
Country: Mexico
Telephone: --
Fax: --
Contact: Oscar Guzman
Telephone: 6621090811
Email: Oguzman@lanix.ciim

1.4.2 Manufacturer (if different from applicant in section 1.4.1)

Name: Shenzhen fortuneship technology,LTD
Address: 6thFloor,KingsonBuilding,NewEnergy Innovation
Industrial Park,No.1Chuangsheng Road, Nanshan
District, Shenzhen, P.R.China

1.4.3 Manufactory (if different from applicant in section 1.4.1)

Name: Shenzhen fortuneship technology.,LTD
Address: 6thFloor,KingsonBuilding,NewEnergy Innovation
Industrial Park,No.1Chuangsheng Road, Nanshan
District, Shenzhen, P.R.China

2 Test Item

2.1 General Information

Manufacturer: Shenzhen fortuneship technology,LTD
 Name: Mobile Phone
 Model Number: U100
 Serial Number: --
 Production Status: Product
 Receipt date of test item: 2015-05-29

2.2 Outline of EUT

E.U.T. is a GSM850/ PCS1900 bands bands Terminal Equipment with Bluetooth.

2.3 Modifications Incorporated in EUT

The EUT has not been modified from what is described by the brand name and unique type identification stated above.

2.4 Equipment Configuration

Equipment configuration list:

Item	Generic Description	Manufacturer	Type	Serial No.	Remarks
A	Mobile Phone	Shenzhen fortuneship technology.,LTD	U100	--	None
B	Battery	None	None	--	None
C	Adaptor	None	None	--	None

2.5 Other Information

--

3 Summary of Test Results

A brief summary of the tests carried out is shown as following.

	Name of Test	Result
1、	Peak power	Pass
2、	Band edge (conducted)	Pass
3、	Frequency separation	Pass
4、	Number of hopping frequency	Pass
5、	Time of occupancy	Pass
6、	Spurious emission (conducted)	Pass
7、	Spurious emission (radiated)	Pass
8、	Power line Conducted Emissions	Pass
Note: none		

TTL Test Report

4 Test Results

4.1 Peak power

Specifications:	15.247 (b)(3)(i),(ii)and(iii)					
Date of Tests	2015-06-05					
Test conditions:	Ambient Temperature:15°C-35°C Relative Humidity:30%-60% Air pressure: 86-106kPa					
Operation Mode	Fix channel transmit					
Test Results:	Pass					
Test equipment Used:						
Asset Number	Description	Manufacturer	Model Number	Serial Number	Cal Due	State
1	EMI Test Receiver	R/S	ESU40	100350	2016-03-05	Normal
2	Wireless Connectivity Test Set	R/S	CMW500	152395	2016-01-28	Normal

LIMIT

The maximum peak output power of the intentional radiator shall not exceed the following:

1. For systems using digital modulation in the bands of 902 - 928 MHz, 2400 - 2483.5 MHz, and 5725 - 5850 MHz: 1 watt.
2. Except as shown in paragraphs (b)(3) (i), (ii) and (iii) of this section, if transmitting antennas of directional gain greater than 6 dBi are used the peak output power from the intentional radiator shall be reduced below the stated values in paragraphs (b)(1) or (b)(2) of this section, as appropriate, by the amount in dB that the directional gain of the antenna exceeds 6 dBi.

Test Setup:

The BLUETOOTH TESTER was used to set the TX channel and power level. The transmitter output is connected to Spectrum analyzer through a coupler.

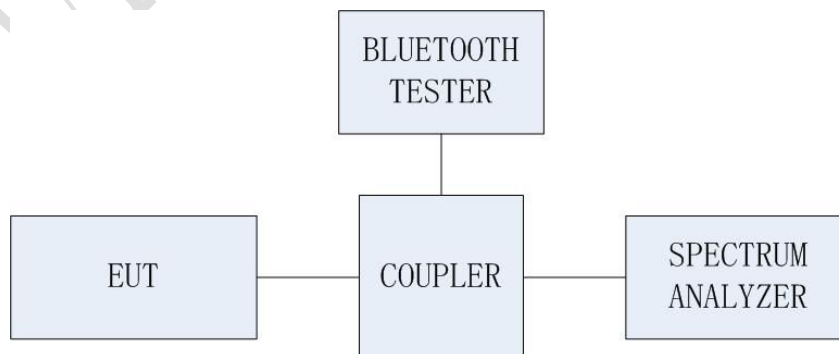

Test procedure:

The transmitter output is connected to the Spectrum Analyzer. The Spectrum Analyzer is set to the peak detector mode. The RBW is set to 3MHz. The VBW is set to 3MHz.

The measurement is made according to Public notice FCC Public Notice DA 00-705, March 2000, and ANSI C63.10-2013.

Test Results:

GFSK:

channel	Frequency (MHz)	Output Power (dBm)	Limit (dBm)	Result
Low: 0	2401.78365	2.91	30	Pass
Middle: 39	2440.71154	2.13	30	Pass
High: 78	2479.62500	1.12	30	pass

Pi/4 DQPSK:

channel	Frequency (MHz)	Output Power (dBm)	Limit (dBm)	Result
Low: 0	2401.74039	3.55	30	Pass
Middle: 39	2440.82692	2.94	30	Pass
High: 78	2479.84135	2.11	30	pass

8DPSK:

channel	Frequency (MHz)	Output Power (dBm)	Limit (dBm)	Result
Low: 0	2401.97112	3.76	30	Pass
Middle: 39	2440.91346	3.17	30	Pass
High: 78	2479.84135	2.38	30	pass

FCC Parts 15 subpart C, ANSI C63.10-2013, FCC DA 00-705
Equipment: U100

REPORT NO.:B15X50225-FCC-BT

Test plots:

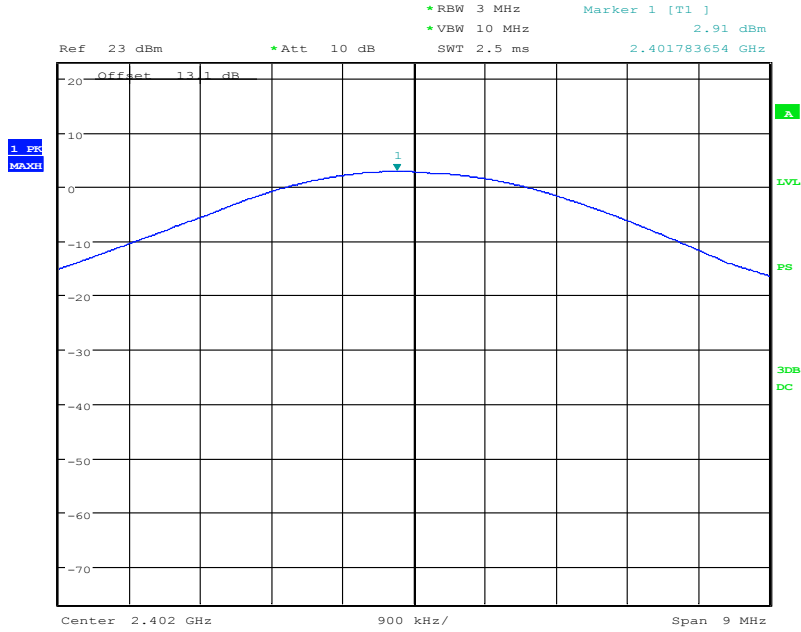

Date: 5.JUN.2015 12:46:51

GFSK Channel 0

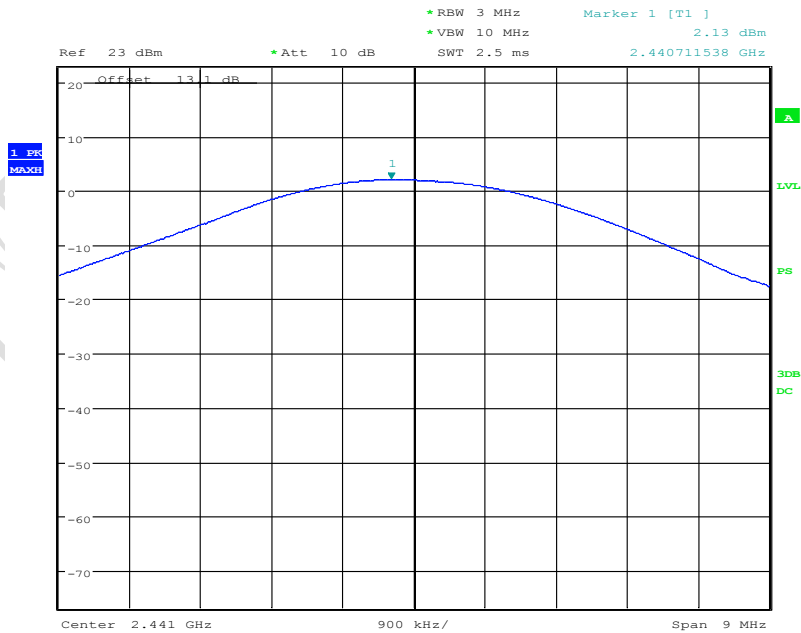

Date: 5.JUN.2015 12:39:59

GFSK Channel 39

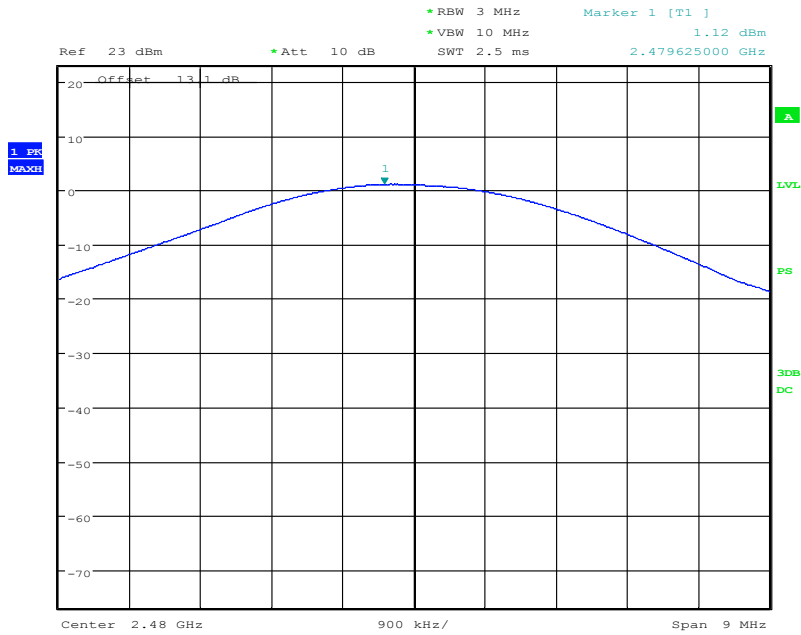

Date: 5.JUN.2015 12:43:26

GFSK Channel 78

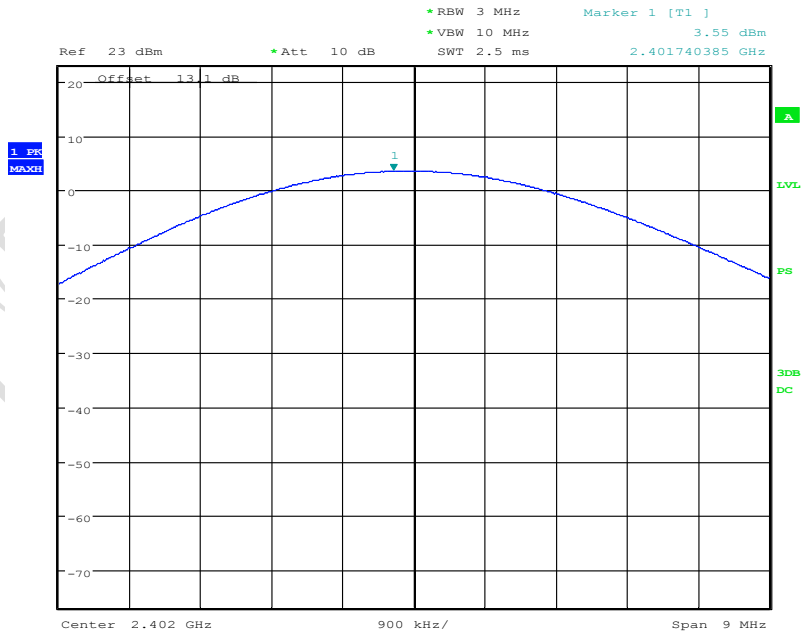

Date: 5.JUN.2015 12:31:50

Pi/4 DQPSK Channel 0

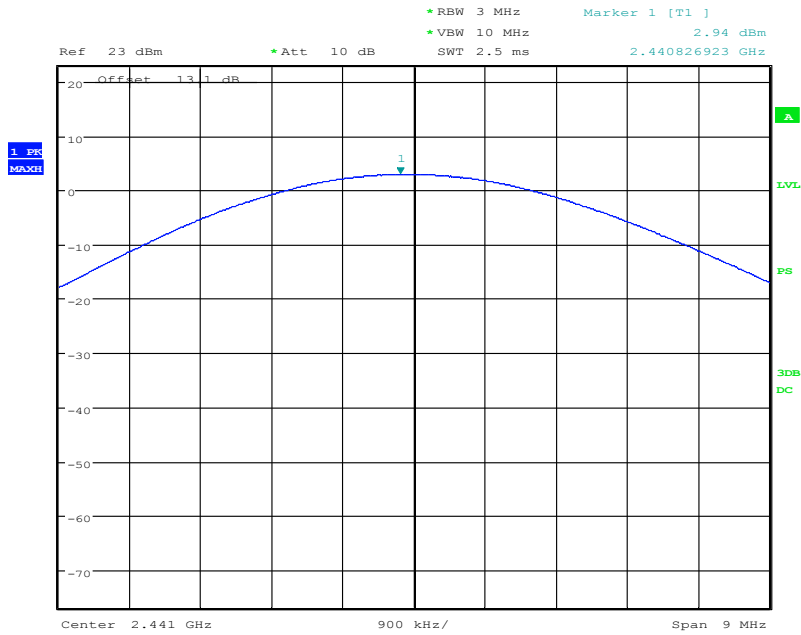

Date: 5.JUN.2015 12:31:26

Pi/4 DQPSK Channel 39

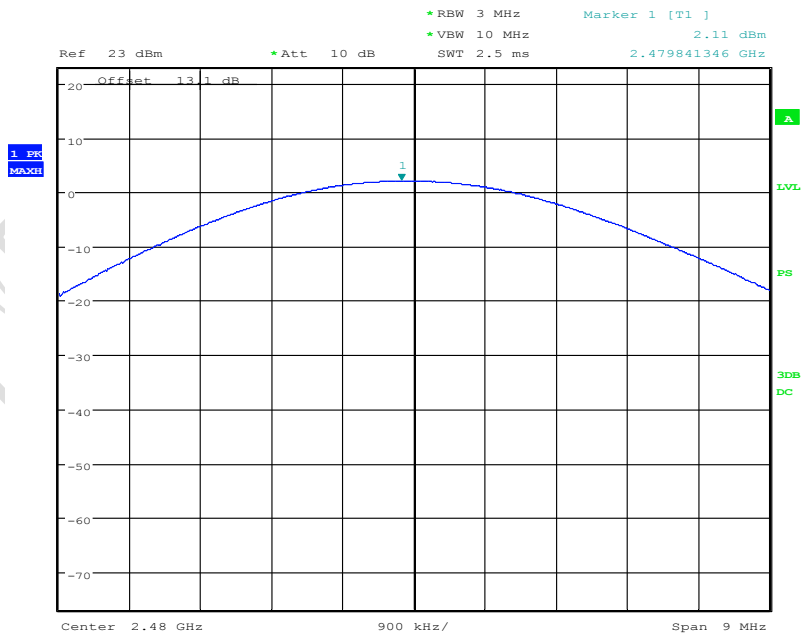

Date: 5.JUN.2015 12:32:14

Pi/4 DQPSK Channel 78

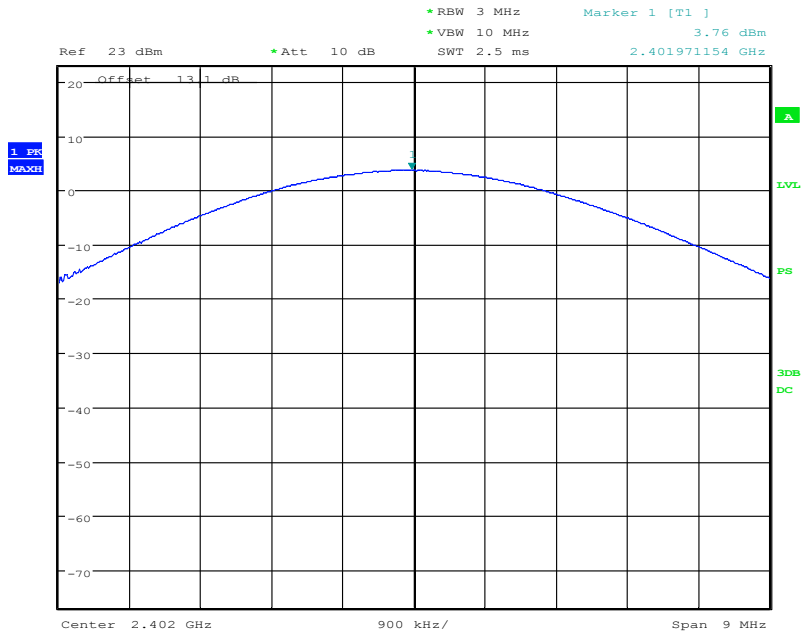

Date: 5.JUN.2015 12:33:31

8DPSK Channel 0

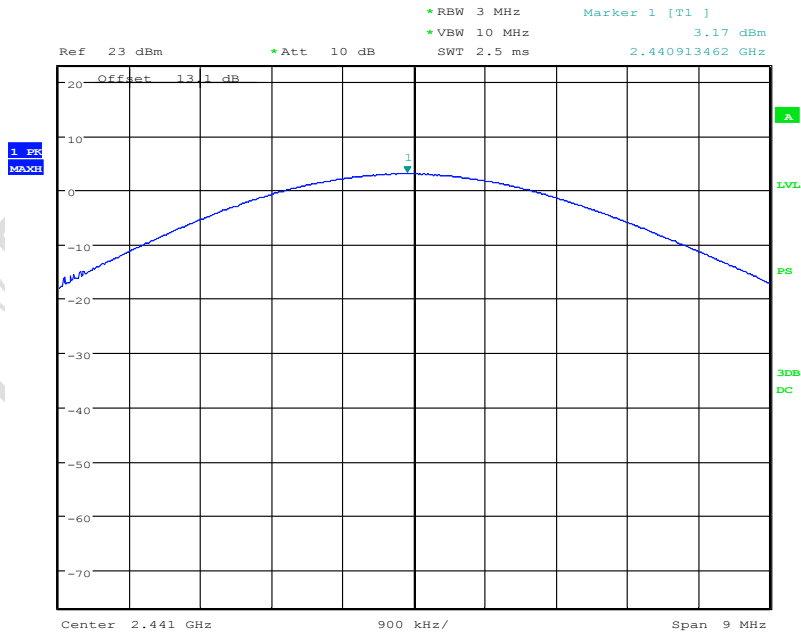

Date: 5.JUN.2015 12:33:07

8DPSK Channel 39

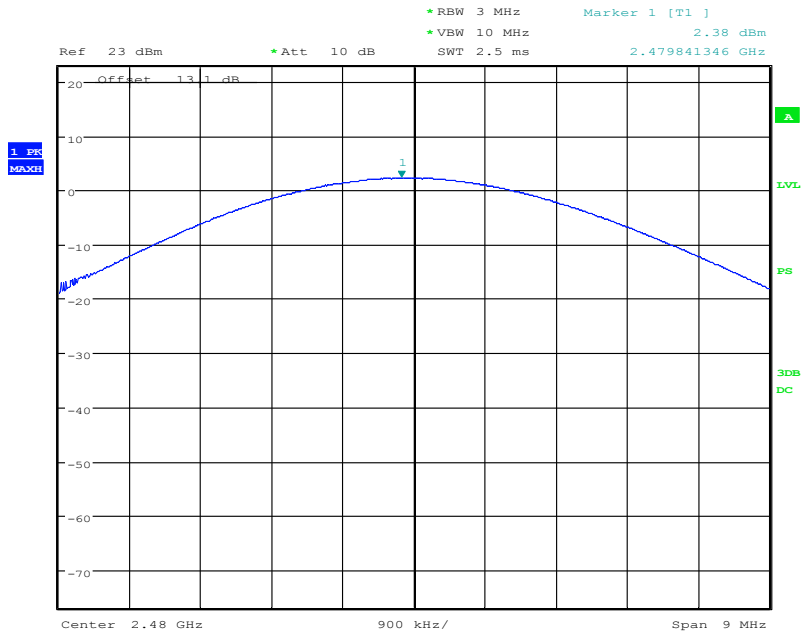

Date: 5.JUN.2015 12:32:43

8DPSK Channel 78

CHINA TEST

4.2 Band edges

Specifications:	15.247 (d)					
Date of Tests	2015-06-03~2015-06-04					
Test conditions:	Ambient Temperature:15°C-35°C Relative Humidity:30%-60% Air pressure: 86-106kPa					
Operation Mode	Maximum transmit					
Test Results:	Pass					
Test equipment Used:						
Asset Number	Description	Manufacturer	Model Number	Serial Number	Cal Due	State
1	EMI Test Receiver	R/S	ESU40	100350	2016-03-05	Normal
2	Wireless Connectivity Test Set	R/S	CMW500	152395	2016-01-28	Normal

LIMIT

Standard	Limited(dBuV/m)	
FCC 47 CFR Part 15.247(d)	Peak	74
	Average	54

Test Setup:

The measurement is according to ANSI C63.10 clause11.13.

- Span: Wide enough to capture the peak level of the emission operating on the channel closest to the band edge, as well as any modulation products that fall outside of the authorized band of operation.
- Reference level offset: Corrected for gains and losses of test antenna factor, preamp gain and cable loss, so as to indicate field strength, in units of dBμV/m at 3 m, directly on the instrument display. Alternatively, the reference level offset may be set to zero and calculations shall be provided showing the conversion of raw measured data to the field strength in dBμV/m at 3 m.
- Reference level: As required to keep the signal from exceeding the maximum spectrum analyzer input mixer level for linear operation. In general, the peak of the spectral envelope shall be more than [10 log (OBW/RBW)] below the reference level. Specific guidance is given in 4.1.5.2..
- Attenuation: Auto (at least 10 dB preferred).
- Sweep time: Coupled.
- Resolution bandwidth: Above 1 GHz: 1 MHz
- Video bandwidth: VBW for Peak, Quasi-peak, or Average Detector Function: 3 × RBW
- Detector (unless specified otherwise): Peak and average above 1 GHz
- Trace: Max hold for final measurement; a combination of two traces, clear-write and max hold, is recommended for maximizing the emission.

GFSK

Channel	Test Results(dBuV/m)			Conclusion
0	Peak	2390.000MHz	41.571	Pass
	Average	2390.000MHz	30.327	
78	Peak	2483.000MHz	40.918	Pass
	Average	2483.000MHz	30.447	

Pi/4 DQPSK

Channel	Test Results(dBuV/m)			Conclusion
0	Peak	2390.000MHz	41.058	Pass
	Average	2390.000MHz	30.337	
78	Peak	2483.000MHz	41.168	Pass
	Average	2483.000MHz	30.352	

8DPSK

Channel	Test Results(dBuV/m)			Conclusion
0	Peak	2390.000MHz	40.600	Pass
	Average	2390.000MHz	30.799	
78	Peak	2483.000MHz	48.954	Pass
	Average	2483.000MHz	30.799	

Test plots:

GFSK Channel 0, fixed mode, left band-edge

BAND EDGERE 1GHz-3GHz 2300-2390

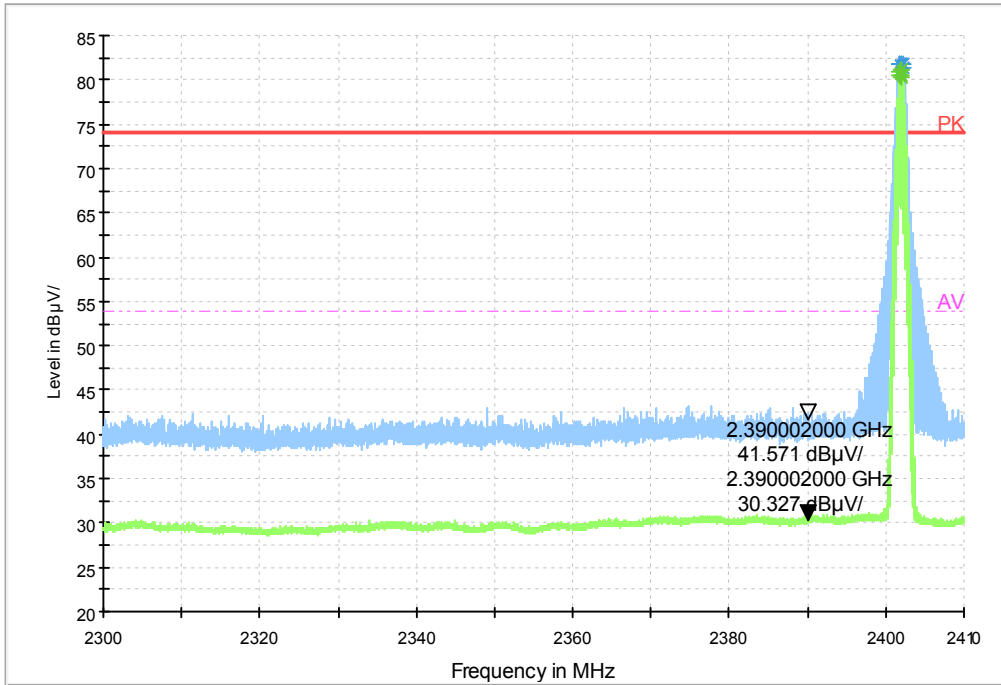

GFSK Channel 78, fixed mode, right band-edge

BAND EDGERE 1GHz-3GHz 2483.5-2500

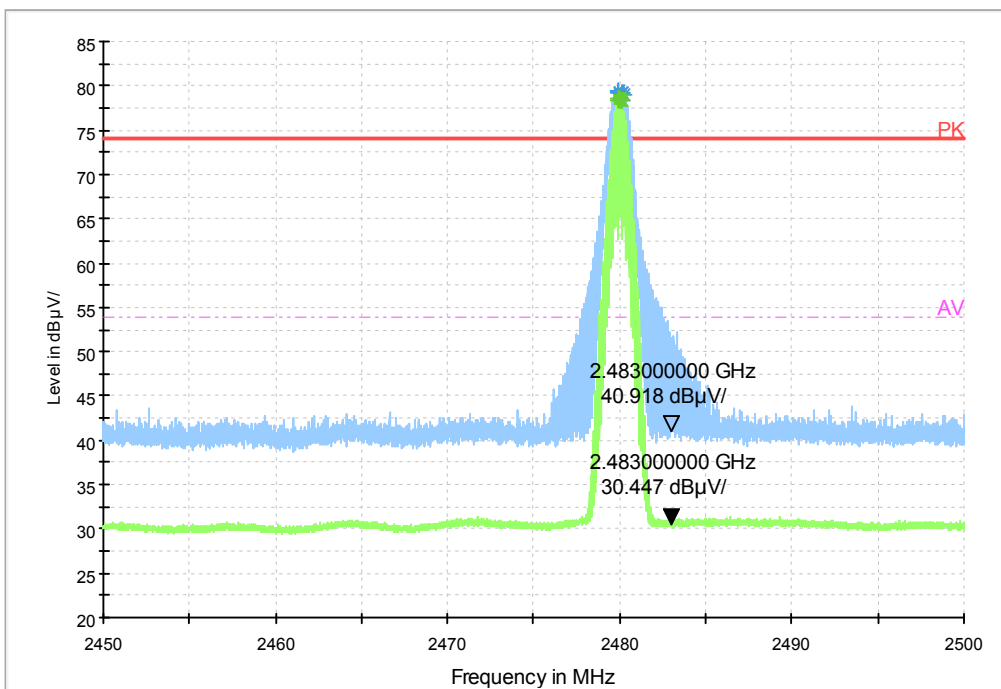

Pi/4 DQPSK Channel 0, fixed mode, left band-edge

BAND EDGERE 1GHz-3GHz 2300-2390

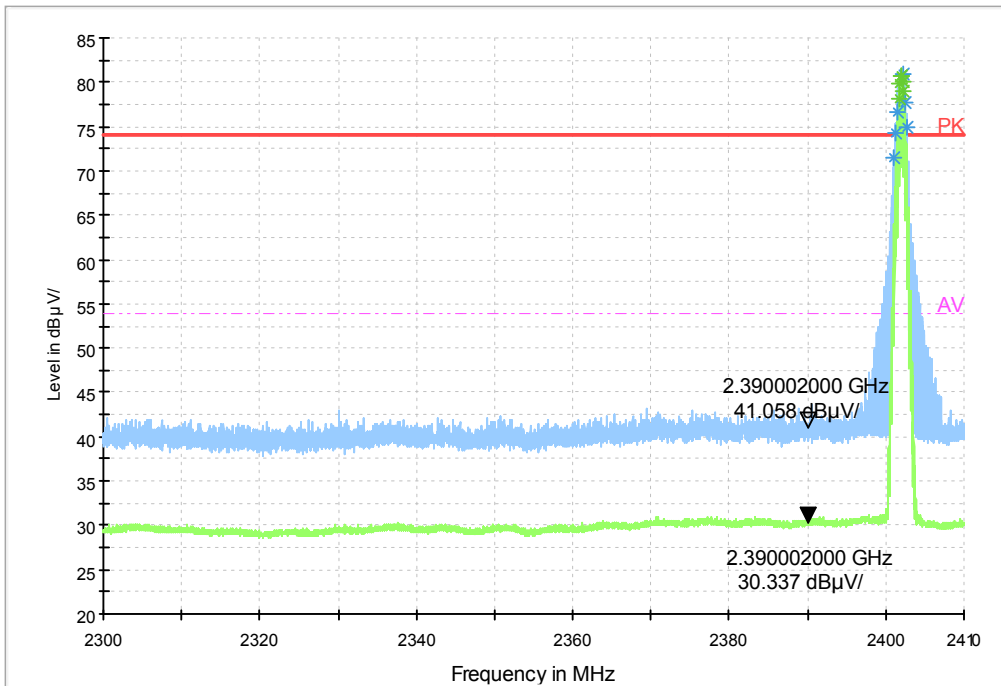

Pi/4 DQPSK Channel 78, fixed mode, right band-edge

BAND EDGERE 1GHz-3GHz 2483.5-2500

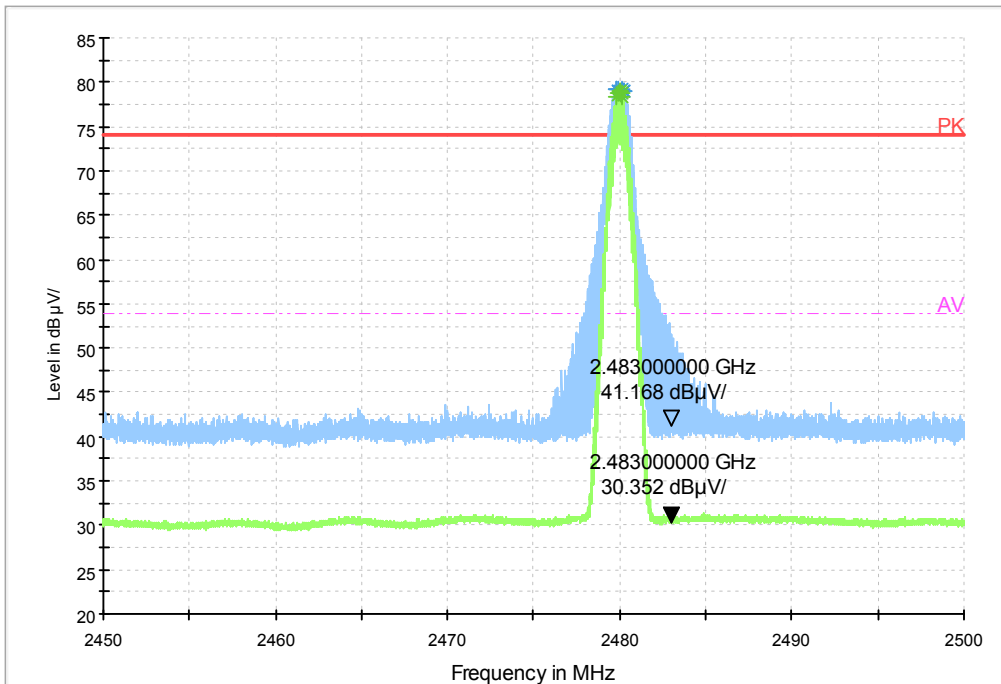

8DPSK Channel 0, fixed mode, left band-edge

BAND EDGERE 1GHz-3GHz 2300-2390

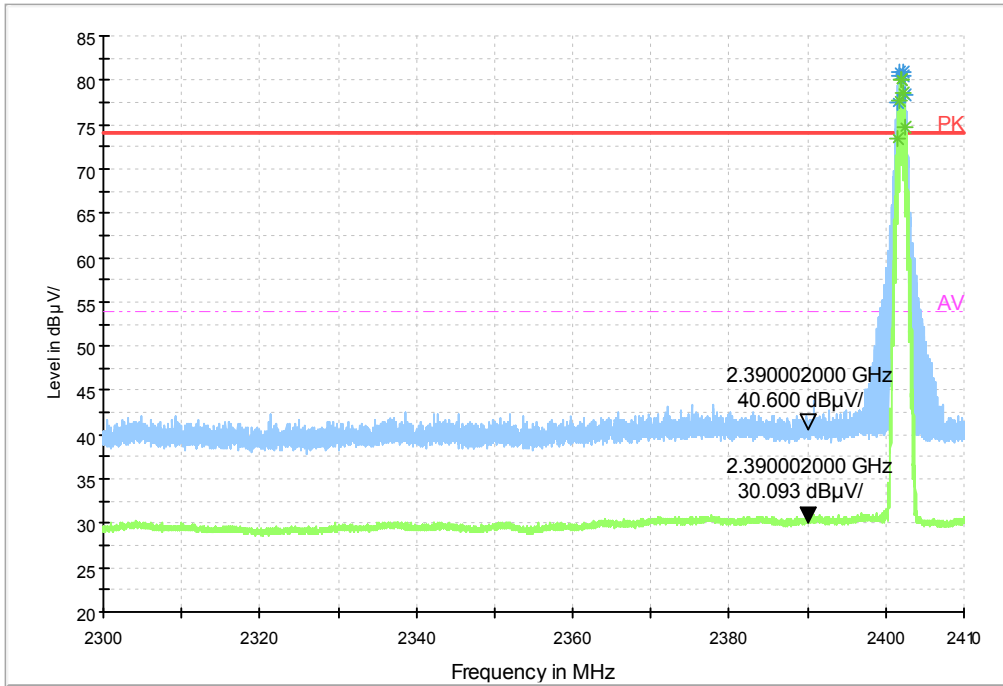

8DPSK Channel 78, fixed mode, right band-edge

BAND EDGERE 1GHz-3GHz 2483.5-2500

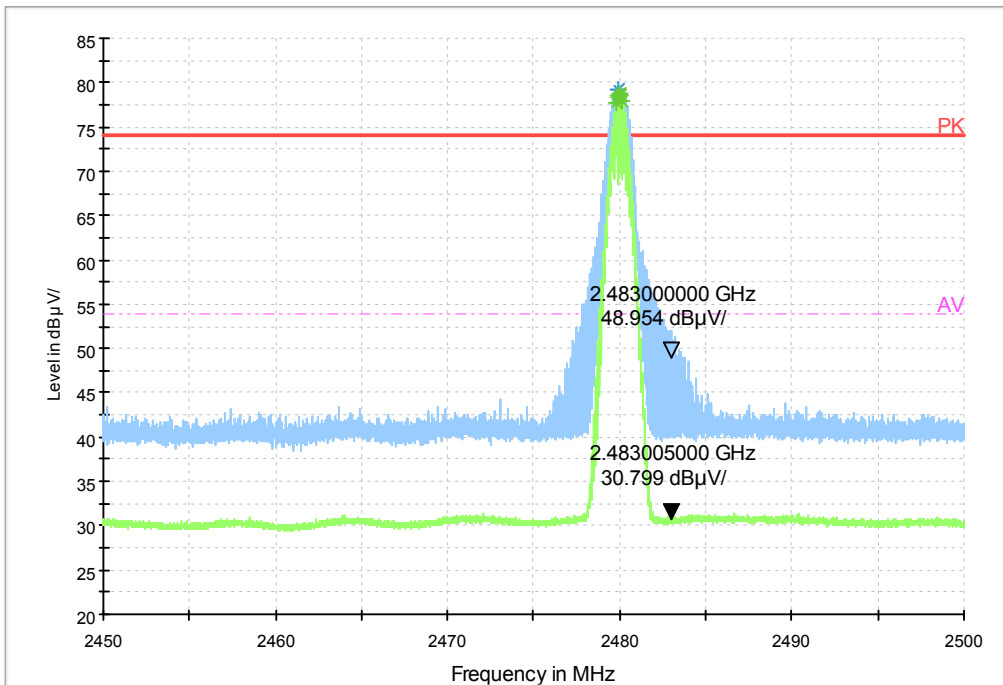

4.3 Frequency separation

Specifications:	15.247(a)(1)					
Date of Test	2015-06-05					
Test conditions:	Ambient Temperature:15°C-35°C Relative Humidity:30%-60% Air pressure: 86-106kPa					
Operation Mode	maximum transmit					
Test Results:	Pass					
Test equipment Used:						
Number	Description	Manufacturer	Model Number	Serial Number	Cal Due	State
1	EMI Test Receiver	R/S	ESU40	100350	2016-03-05	Normal
2	Wireless Connectivity Test Set	R/S	CMW500	152395	2016-01-28	Normal

LIMIT

According to §15.247(a)(1), Frequency hopping systems shall have hopping channel carrier frequencies separated by minimum of 25 kHz or 2/3 of the 20 dB bandwidth of the hopping channel (note), whichever is greater.

Note: it is for the power of less than 125 mw, and for others it is 20 dB bandwidth of the hopping channel.

Test Setup

The BLUETOOTH TESTER was used to set the TX channel and power level. The transmitter output is connected to Spectrum analyzer through a coupler.

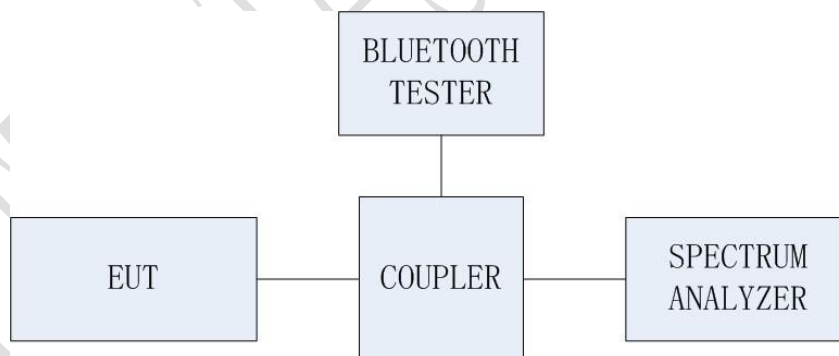

TEST PROCEDURE

The spectrum analyzer is set to:

1. 20dBc Bandwidth: Span = 3 MHz, RBW=20 kHz, VBW=50 kHz, Sweep=auto.
2. Carrier Frequency Separation: Span = 3 MHz, RBW=100 kHz, VBW=300 kHz, Sweep=auto.

The trace was allowed to stabilize. The marker-delta function was used to determine the separation between the peaks of the adjacent channels.

The measurement is made according to Public notice FCC Public Notice DA 00-705, March 2000, and ANSI C63.10-2013.

Test Result:

20dBc bandwidth

Channel separation	20dB Bandwidth (kHz)		Limit (kHz)	Result
GFSK				
682	Ch 0	880	>25	Pass
	Ch 39	918	>25	Pass
	Ch 78	880	>25	Pass
Pi/4 DQPSK				
986	Ch 0	1298	>25	Pass
	Ch 39	1327	>25	Pass
	Ch 78	1327	>25	Pass
8DPSK				
1019	Ch 0	1308	>25	Pass
	Ch 39	1308	>25	Pass
	Ch 78	1308	>25	Pass

Test plots:

Channel Separation (GFSK)

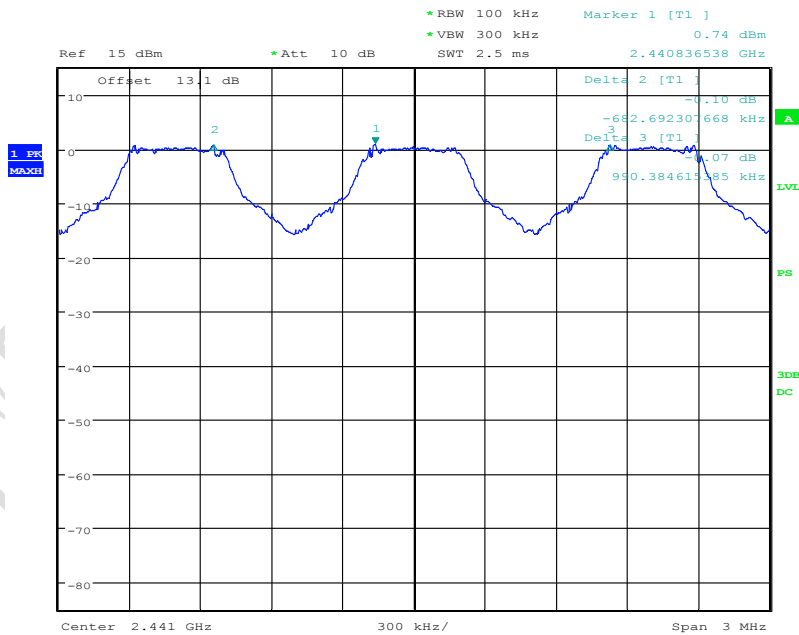

Date: 5.JUN.2015 13:02:56

20dB Bandwidth (GFSK Ch 0)

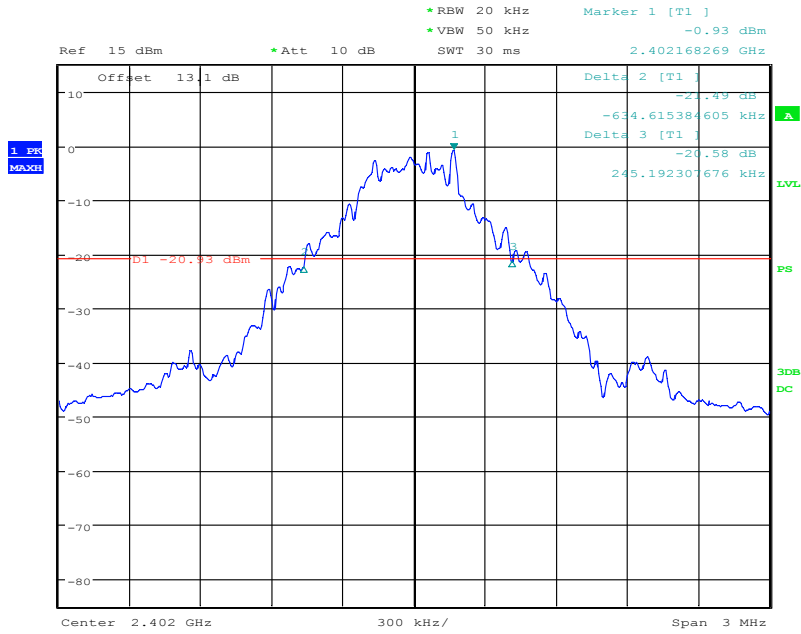

Date: 5.JUN.2015 13:05:21

20dB Bandwidth (GFSK Ch 39)

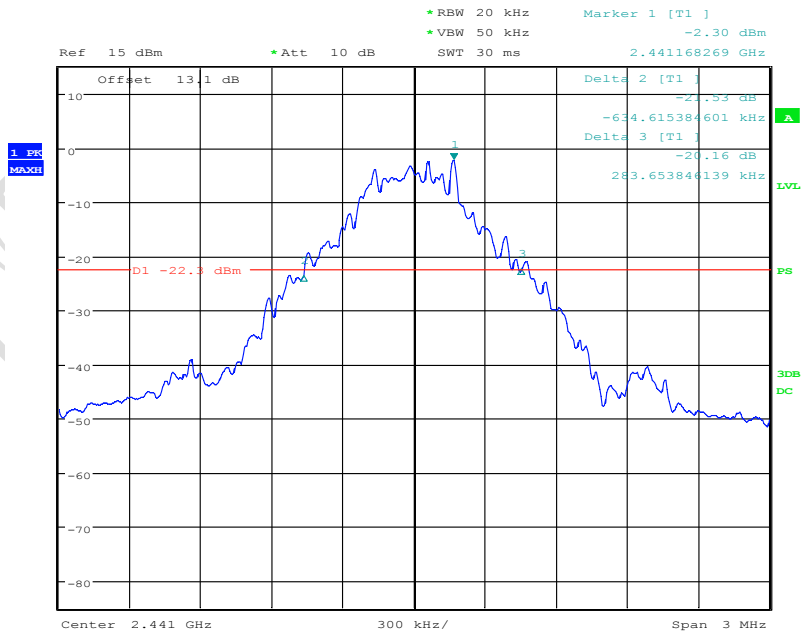

Date: 5.JUN.2015 13:06:43

20dB Bandwidth (GFSK Ch 78)

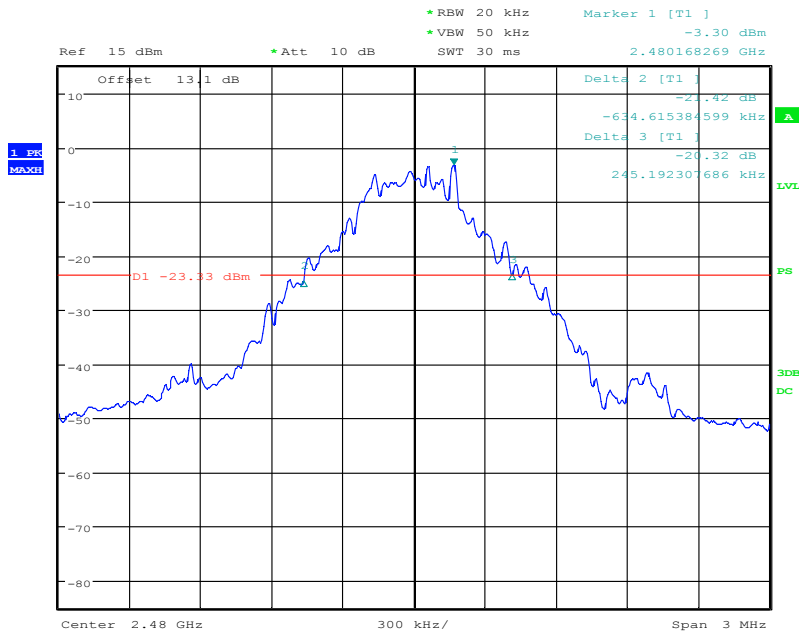

Date: 5.JUN.2015 13:07:54

Channel Separation (Pi/4 DQPSK)

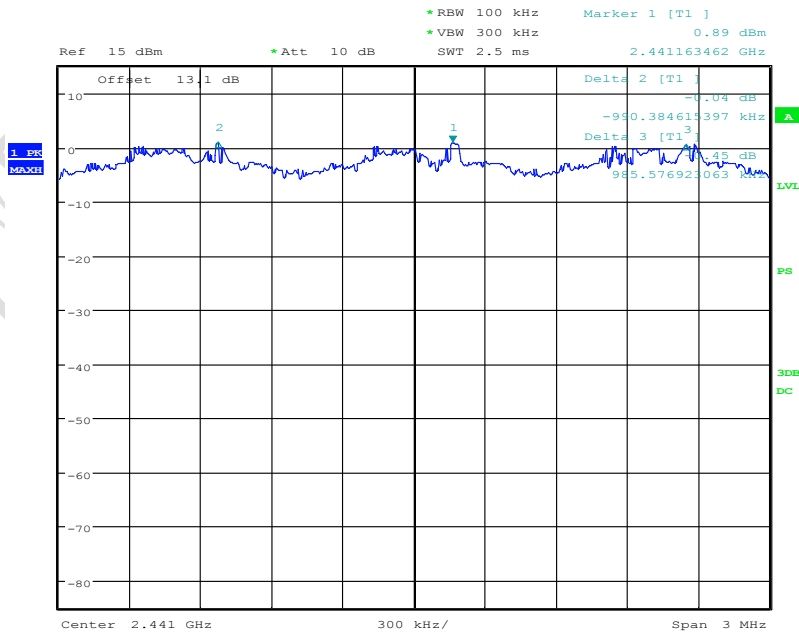

Date: 5.JUN.2015 13:15:27

FCC Parts 15 subpart C, ANSI C63.10-2013, FCC DA 00-705
Equipment: U100

REPORT NO.:B15X50225-FCC-BT

20dB Bandwidth (Pi/4 DQPSK Ch0)

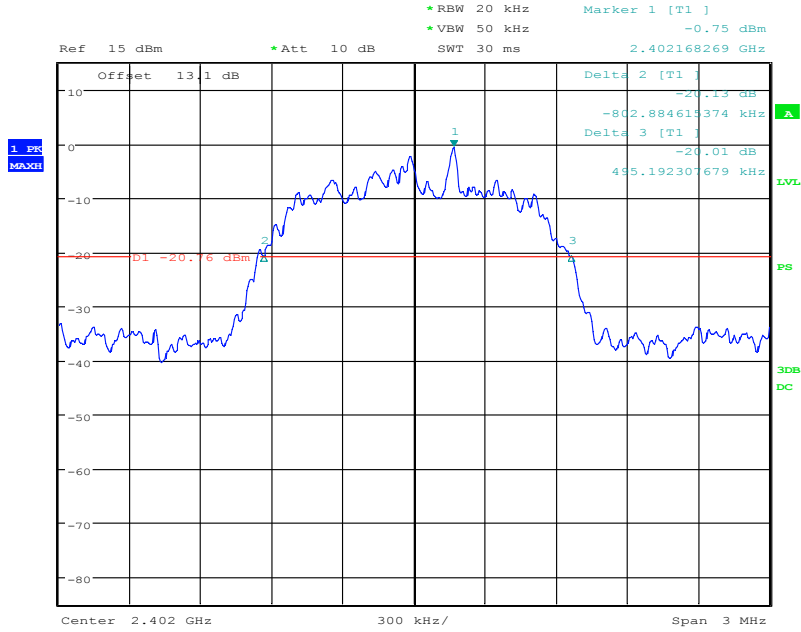

Date: 5.JUN.2015 13:16:48

20dB Bandwidth (Pi/4 DQPSK Ch39)

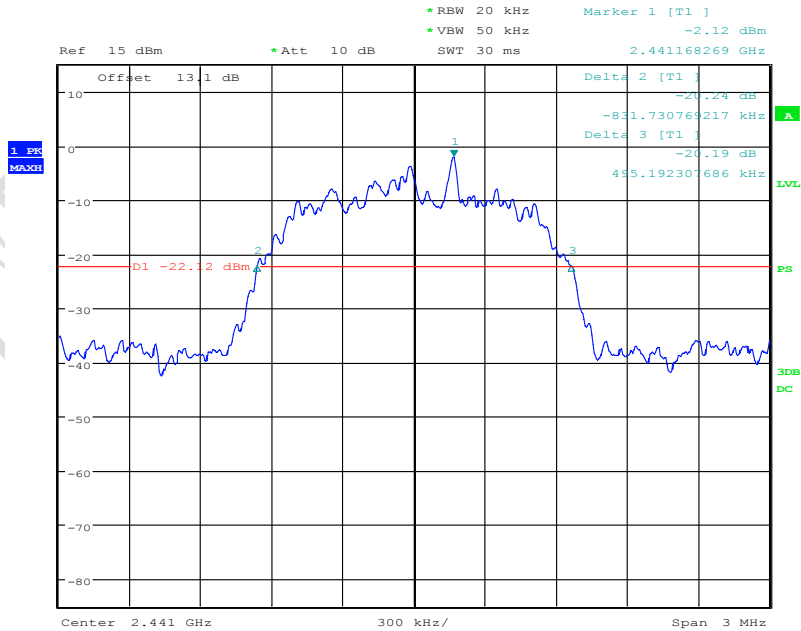

Date: 5.JUN.2015 13:18:11

20dB Bandwidth (Pi/4 DQPSK Ch78)

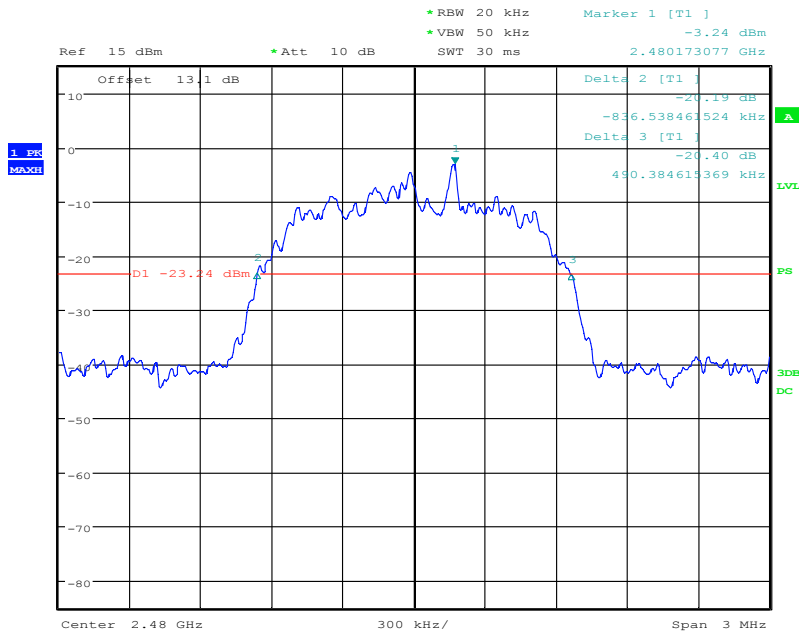

Date: 5.JUN.2015 13:19:23

Channel Separation (8DPSK)

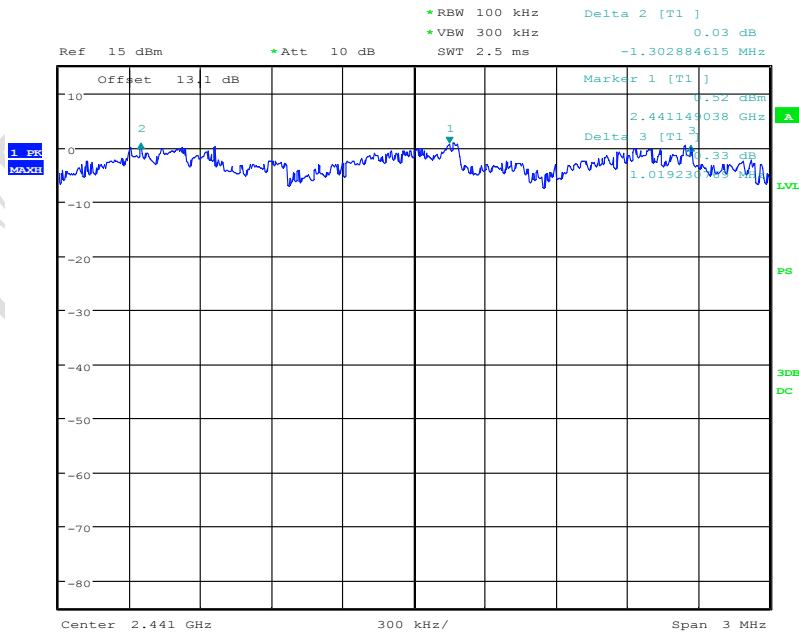

Date: 5.JUN.2015 13:22:40

20dB Bandwidth (8DPSK Ch0)

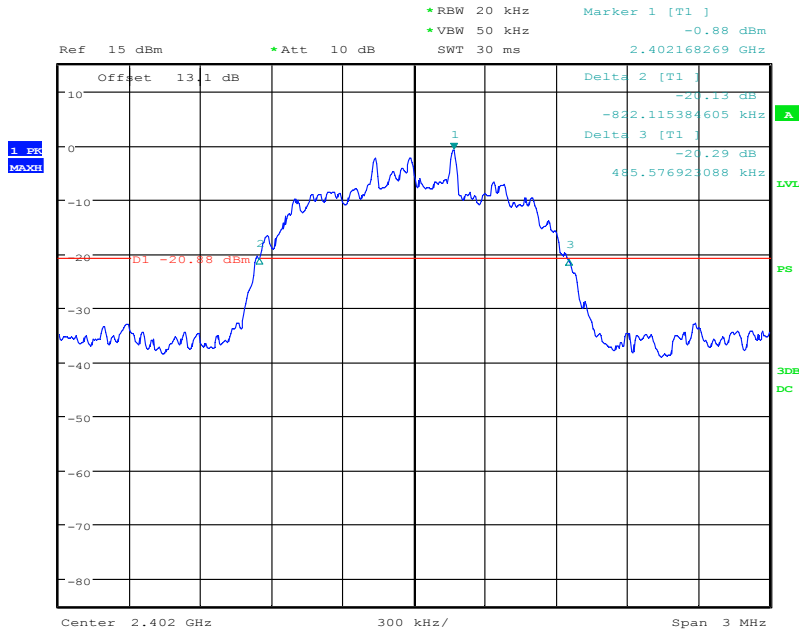

Date: 5.JUN.2015 13:24:41

20dB Bandwidth (8DPSK Ch39)

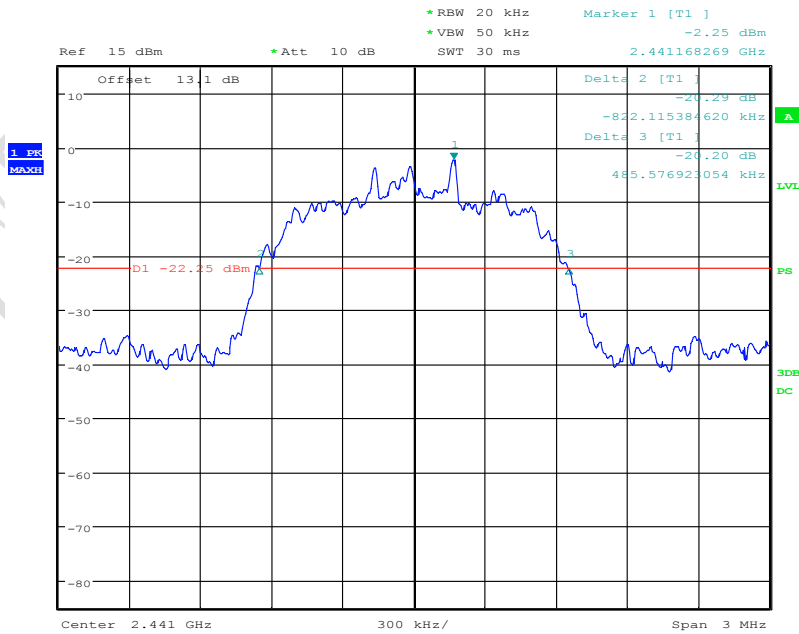

Date: 5.JUN.2015 13:27:31

20dB Bandwidth (8DPSK Ch78)

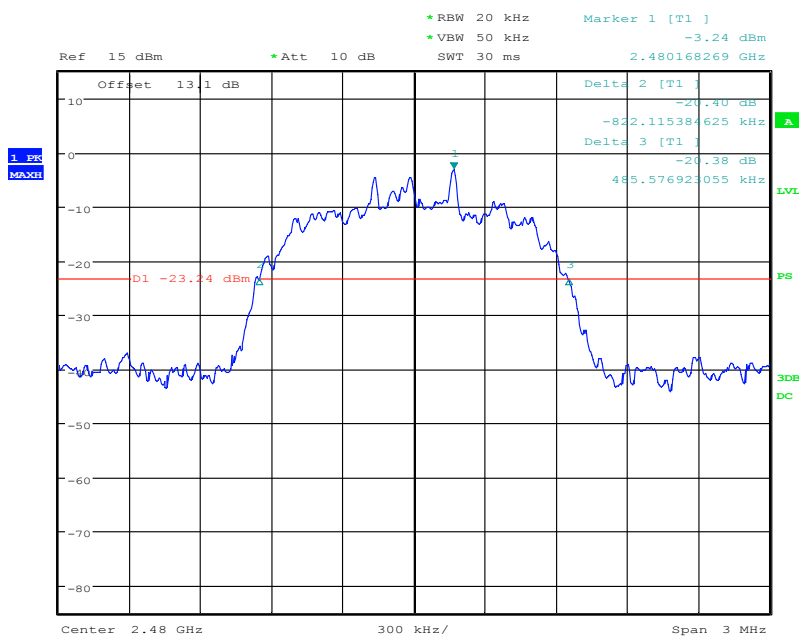

Date: 5.JUN.2015 13:29:09

CHINA TEST

4.4 Number of hopping frequency

Specifications:	15.247(a)(1)(ii)					
Date of Test	2015-06-05					
Test conditions:	Ambient Temperature: 15°C-35°C Relative Humidity: 30%-60% Air pressure: 86-106kPa					
Operation Mode	hopping					
Test Results:	Pass					
Test equipment Used:						
Number	Description	Manufacturer	Model Number	Serial Number	Cal Due	State
1	EMI Test Receiver	R/S	ESU40	100350	2016-03-05	Normal
2	Wireless Connectivity Test Set	R/S	CMW500	152395	2016-01-28	Normal

LIMIT

According to §15.247(a)(1)(ii), Frequency hopping systems operating in the 2400 MHz - 2483.5 MHz bands shall use at least 15 hopping frequencies.

Test Setup

The BLUETOOTH TESTER was used to set the TX channel and power level. The transmitter output is connected to Spectrum analyzer through a coupler.

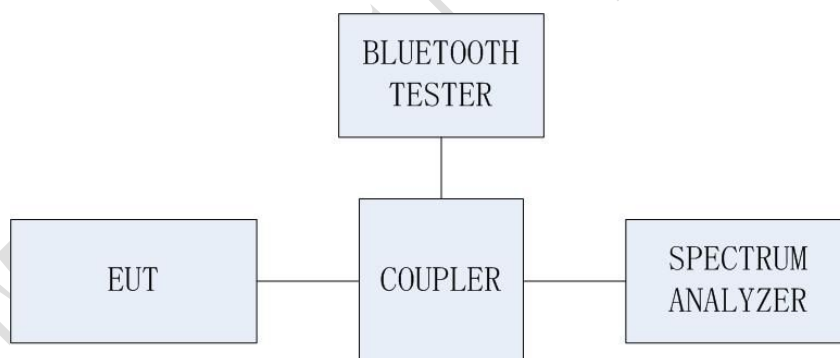

TEST PROCEDURE

The Bluetooth frequency hopping function of the EUT was enabled. The spectrum analyzer was set to:

1. Span = the frequency band of operation, i.e. 2400-2441MHz and 2441-2484 MHz
2. RBW = 500 KHz
3. VBW = 500 KHz
4. Sweep = auto

The trace was allowed to stabilize.

The measurement is made according to Public notice FCC Public Notice DA 00-705, March 2000, and ANSI C63.10-2013.

Test Result:

Modulation	No. OF channels	Limit (No. of Ch)	Result
GFSK	79	>75	Pass
Pi/4 DQPSK	79	>75	Pass
8DPSK	79	>75	Pass

Test plot:

Channel Number (GFSK)

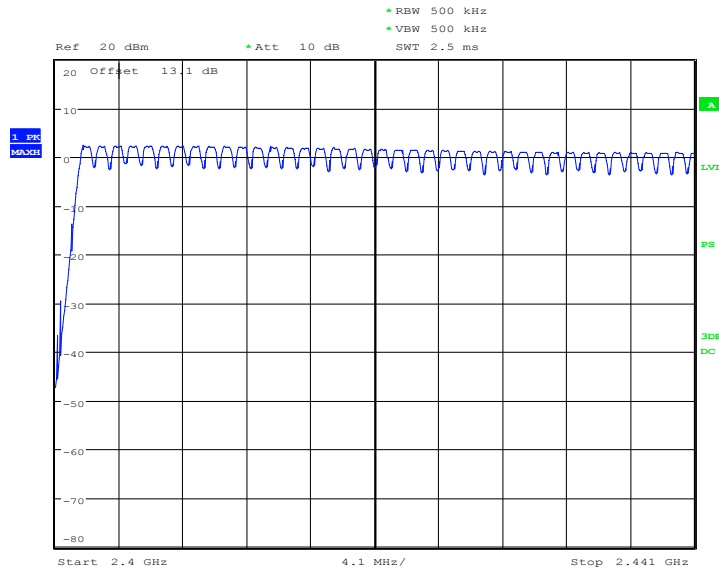

Date: 5.JUN.2015 13:51:13

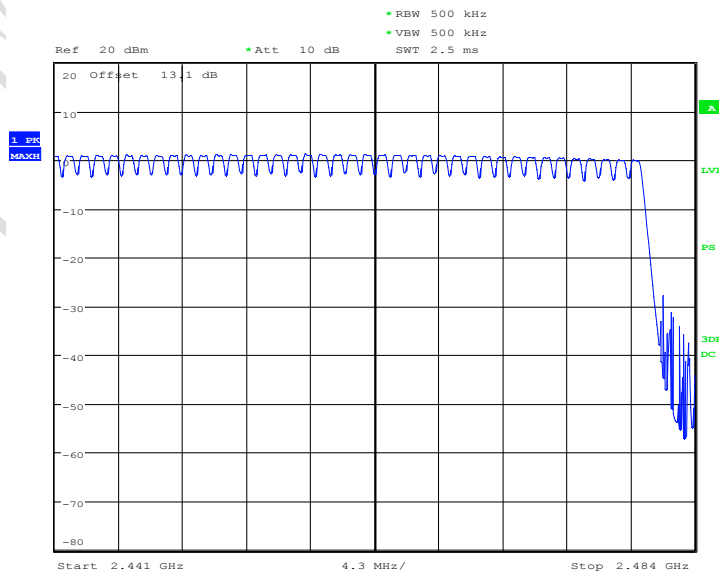

Date: 5.JUN.2015 13:52:54

Channel Number (Pi/4 DQPSK)

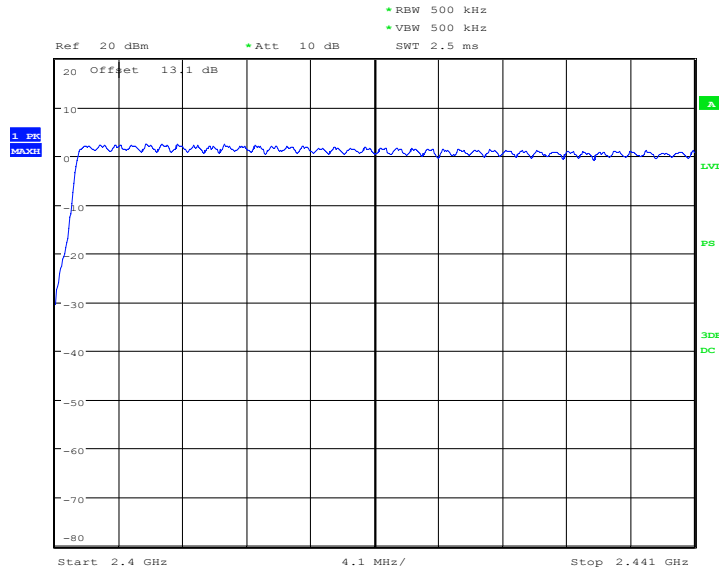

Date: 5.JUN.2015 13:50:23

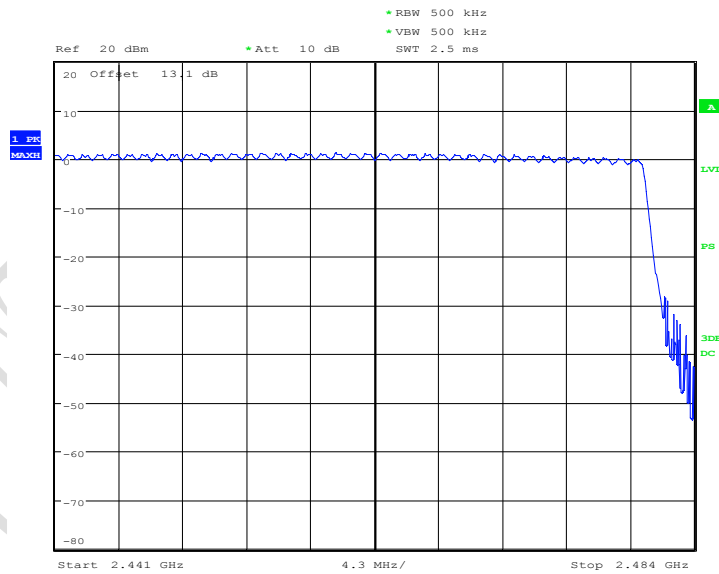

Date: 5.JUN.2015 13:48:36

Channel Number (8DPSK)

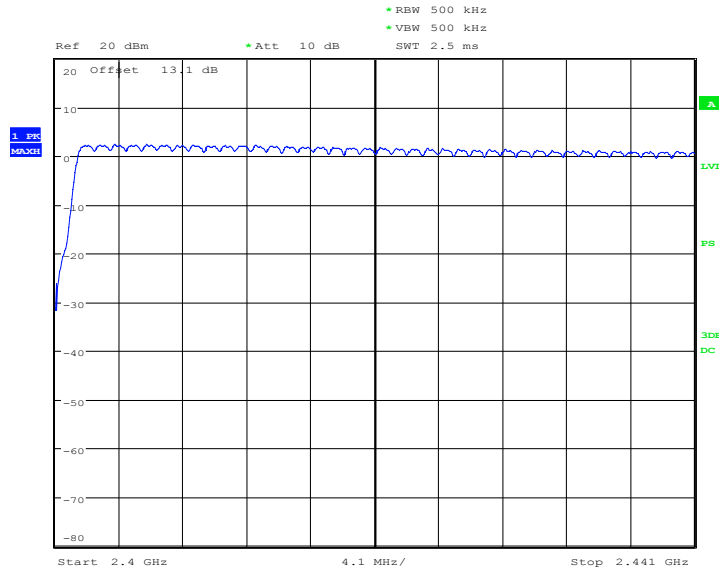

Date: 5.JUN.2015 13:35:51

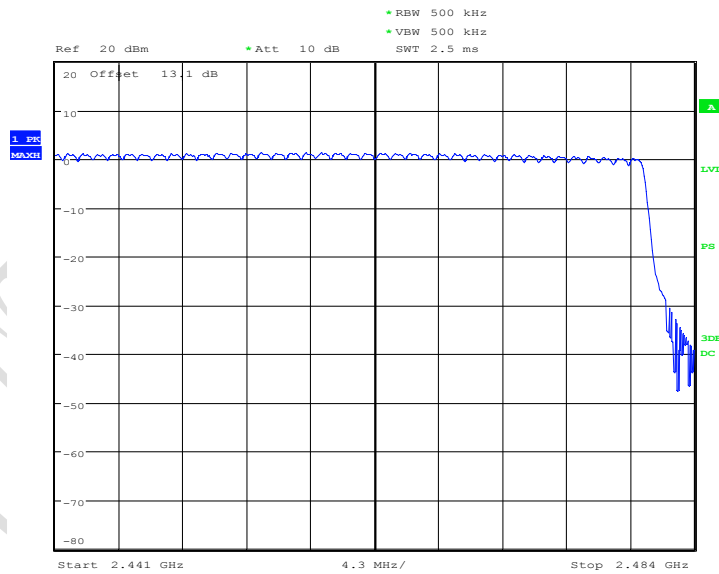

Date: 5.JUN.2015 13:44:44

4.5 Time of occupancy

Specifications:	15.247(a)(1)(iii)					
Date of Test	2015-06-05					
Test conditions:	Ambient Temperature:15°C-35°C Relative Humidity:30%-60% Air pressure: 86-106kPa					
Operation Mode	Fix channel					
Test Results:	Pass					
Test equipment Used:						
Number	Description	Manufacturer	Model Number	Serial Number	Cal Due	State
1	EMI Test Receiver	R/S	ESU40	100350	2016-03-05	Normal
2	Wireless Connectivity Test Set	R/S	CMW500	152395	2016-01-28	Normal

LIMIT

According to §15.247(a)(1)(iii), Frequency hopping systems operating in the 2400 MHz - 2483.5 MHz bands. The average time of occupancy on any channels shall not greater than 0.4 s within a period 0.4 s multiplied by the number of hopping channels employed.

Test Setup

The BLUETOOTH TESTER was used to set the TX channel and power level. The transmitter output is connected to Spectrum analyzer through a coupling.

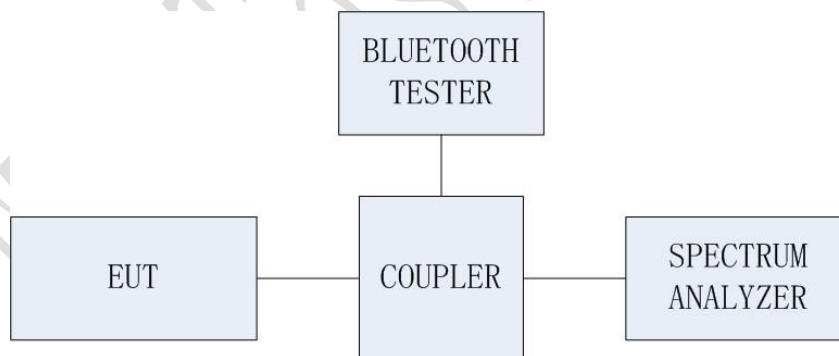

TEST PROCEDURE

The spectrum analyzer is set to:

1. Span = zero span
2. RBW = 1 MHz
3. VBW = 3 MHz
4. Sweep = as necessary to capture the entire dwell time per channel

The marker-delta function was used to determine the dwell time.

The measurement is made according to Public notice FCC Public Notice DA 00-705, March 2000, and ANSI C63.10-2013.

Test Result:

GFSK DH1:

$$0.3798 * (1600/2) / 79 * 31.6 = 122\text{ms}$$

Pulse time[ms]	Total dwell[ms]	Period time[s]	result
0.3798	122	31.6	PASS

GFSK DH3:

$$1.638 * (1600/4) / 79 * 31.6 = 262\text{ms}$$

Pulse time[ms]	Total dwell[ms]	Period time[s]	result
1.638	262	31.6	PASS

GFSK DH5:

$$2.869 * (1600/6) / 79 * 31.6 = 306\text{ms}$$

Pulse time[ms]	Total dwell[ms]	Period time[s]	result
2.869	306	31.6	PASS

Pi/4 DQPSK 2DH1:

$$0.3798 * (1600/2) / 79 * 31.6 = 122\text{ms}$$

Pulse time[ms]	Total dwell[ms]	Period time[s]	result
0.3798	122	31.6	PASS

Pi/4 DQPSK 2DH3:

$$1.625 * (1600/4) / 79 * 31.6 = 260\text{ms}$$

Pulse time[ms]	Total dwell[ms]	Period time[s]	result
1.625	260	31.6	PASS

Pi/4 DQPSK 2DH5:

$$2.859 * (1600/6) / 79 * 31.6 = 305\text{ms}$$

Pulse time[ms]	Total dwell[ms]	Period time[s]	result
2.859	305	31.6	PASS

FCC Parts 15 subpart C, ANSI C63.10-2013, FCC DA 00-705
Equipment: U100

REPORT NO.:B15X50225-FCC-BT

8DPSK 3DH1:

$$0.3814 * (1600/2) / 79 * 31.6 = 122\text{ms}$$

Pulse time[ms]	Total dwell[ms]	Period time[s]	result
0.3814	122	31.6	PASS

8DPSK 3DH3:

$$1.615 * (1600/4) / 79 * 31.6 = 258\text{ms}$$

Pulse time[ms]	Total dwell[ms]	Period time[s]	result
1.615	258	31.6	PASS

8DPSK 3DH5:

$$2.865 * (1600/6) / 79 * 31.6 = 306\text{ms}$$

Pulse time[ms]	Total dwell[ms]	Period time[s]	result
2.865	306	31.6	PASS

Test data:
GFSK DH1

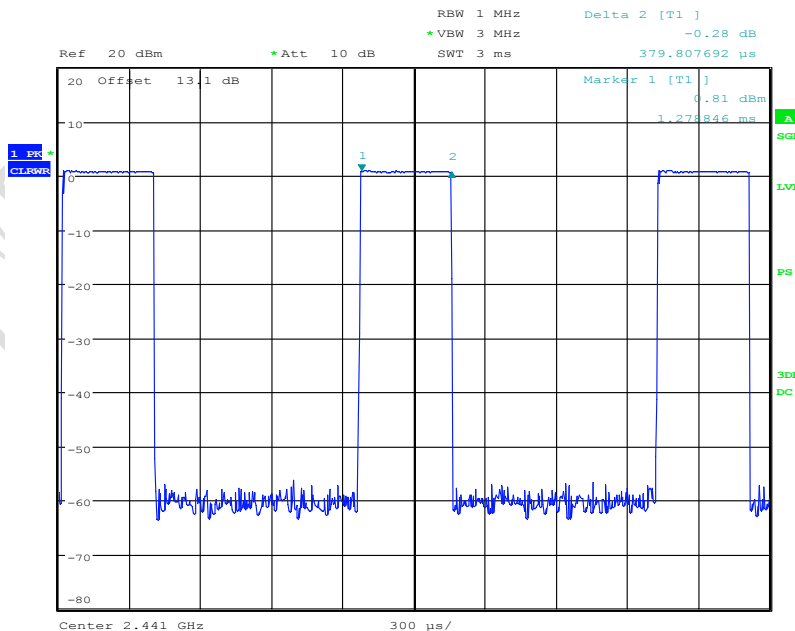

Date: 5.JUN.2015 14:01:15

GFSK DH3

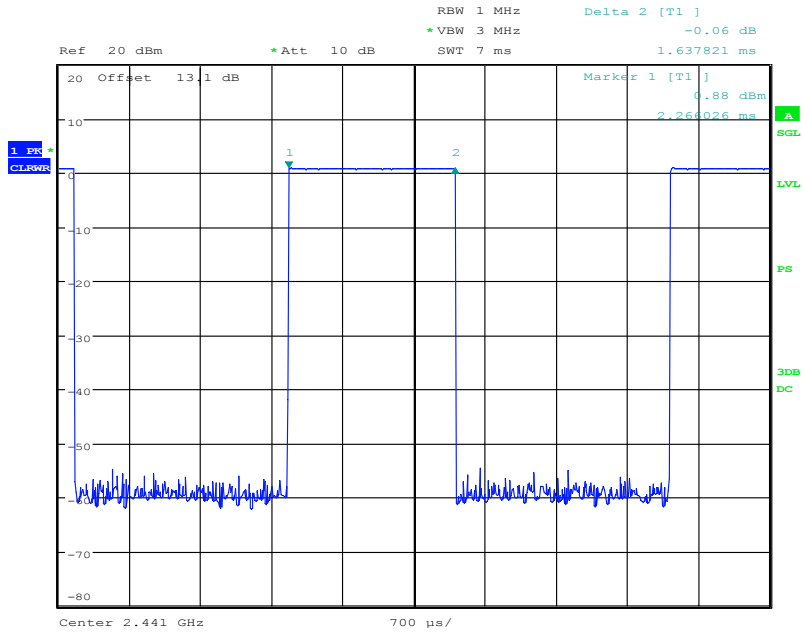

Date: 5.JUN.2015 14:03:29

GFSK DH5

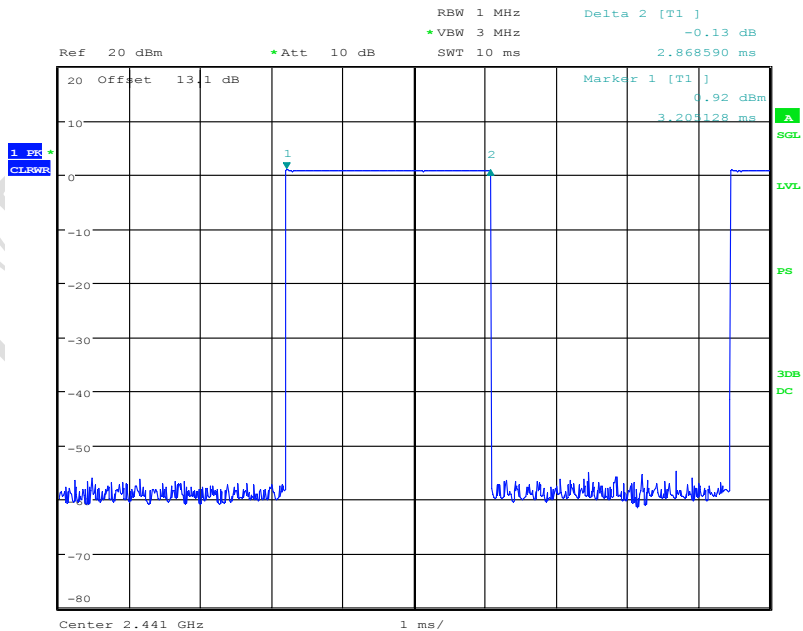

Date: 5.JUN.2015 14:04:35

FCC Parts 15 subpart C, ANSI C63.10-2013, FCC DA 00-705
Equipment: U100

REPORT NO.:B15X50225-FCC-BT

Pi/4 DQPSK 2DH1

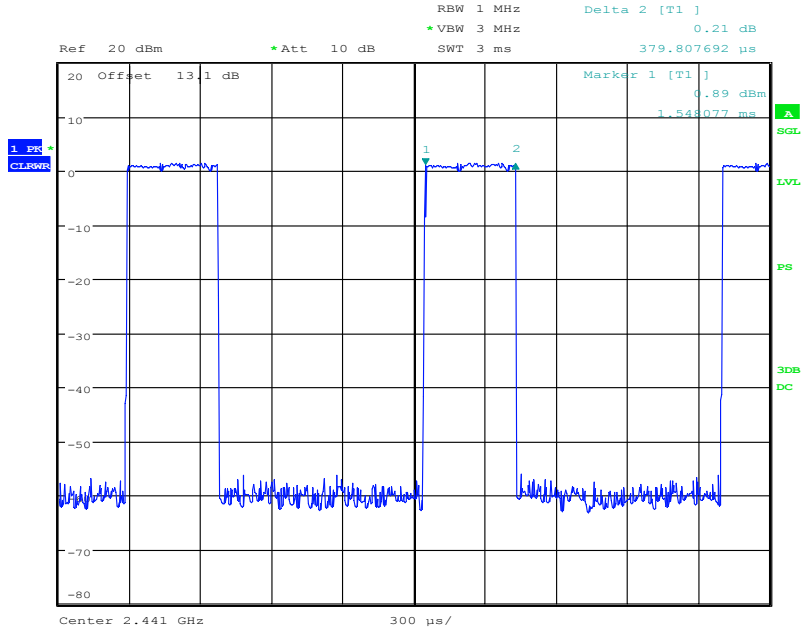

Date: 5.JUN.2015 14:05:42

Pi/4 DQPSK 2DH3

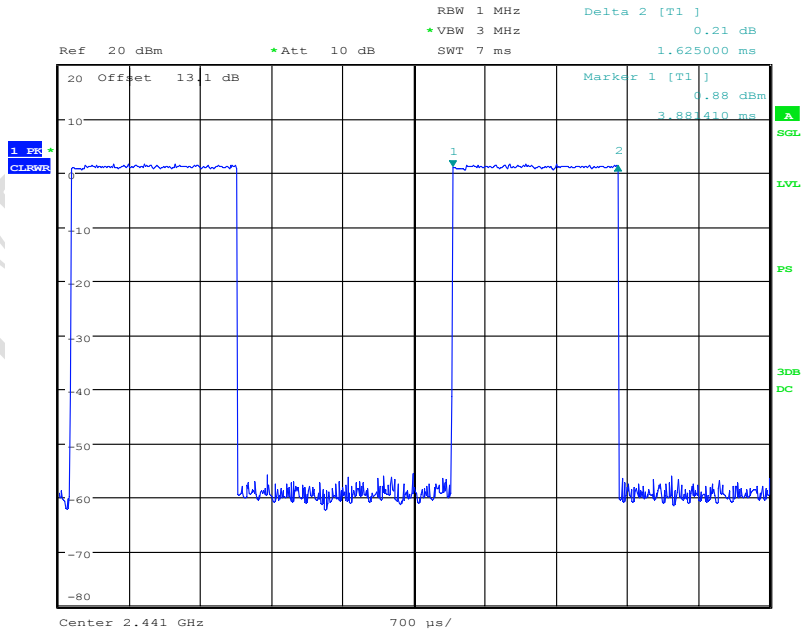

Date: 5.JUN.2015 14:06:48

Pi/4 DQPSK 2DH5

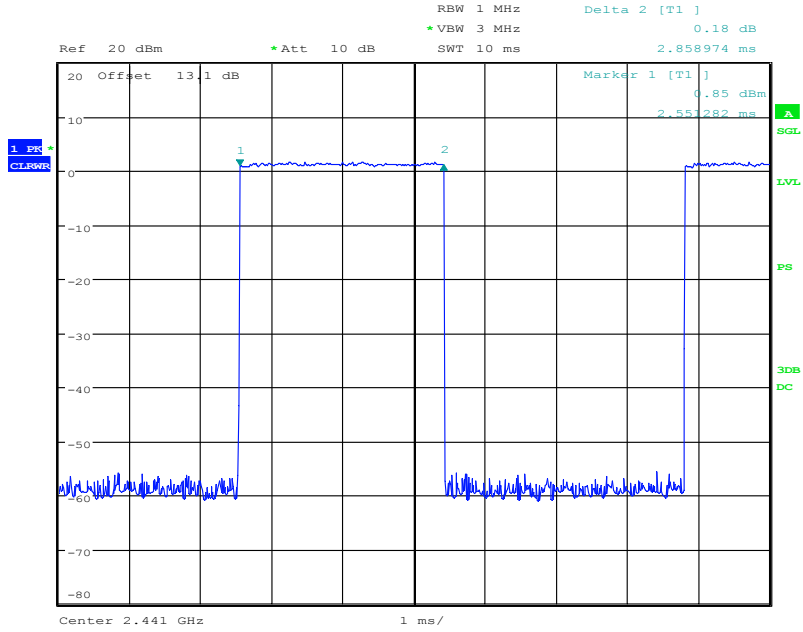

Date: 5.JUN.2015 14:07:45

8DPSK 3DH1

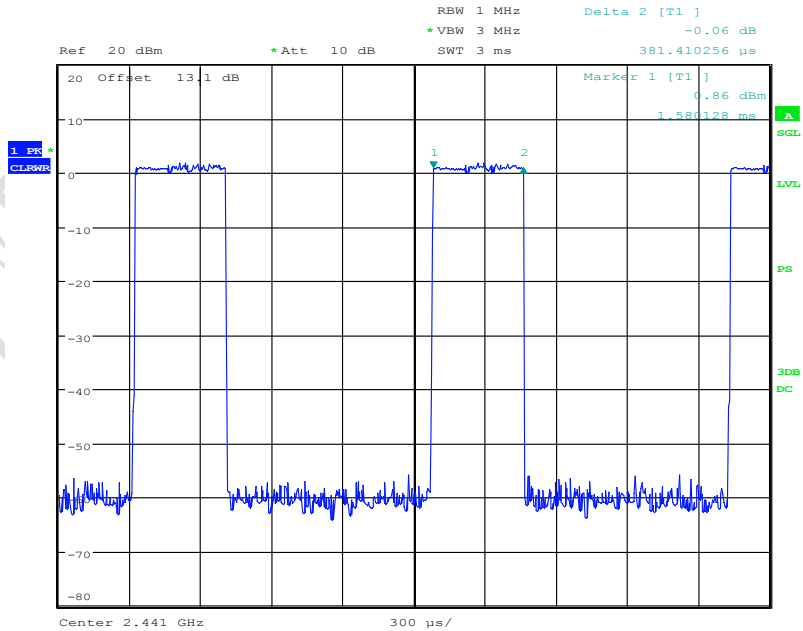

Date: 5.JUN.2015 14:08:32

FCC Parts 15 subpart C, ANSI C63.10-2013, FCC DA 00-705
Equipment: U100

REPORT NO.:B15X50225-FCC-BT

8DPSK 3DH3

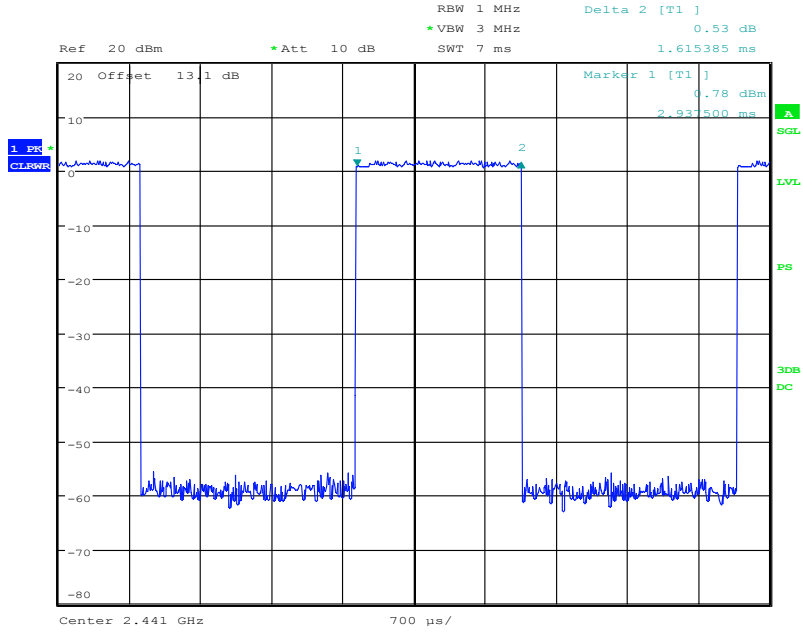

Date: 5.JUN.2015 14:09:02

8DPSK 3DH5

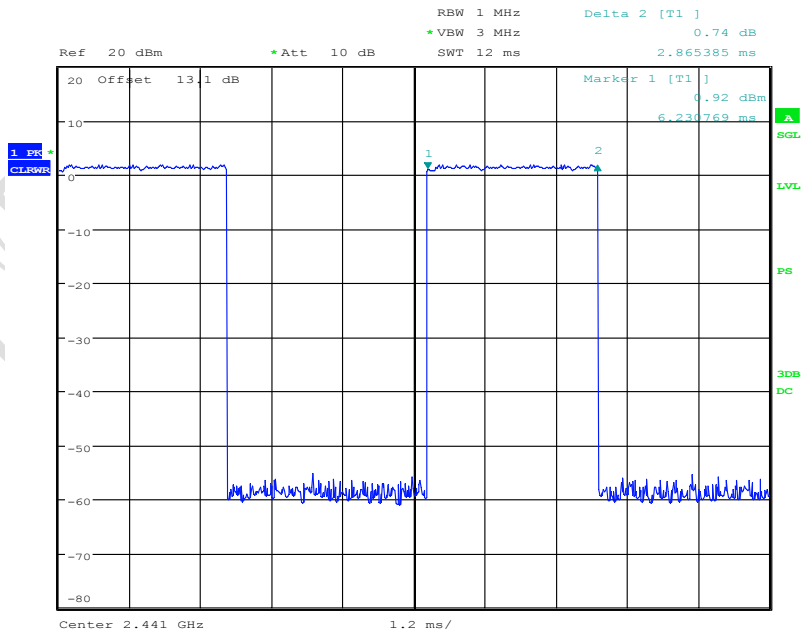

Date: 5.JUN.2015 14:10:01

4.6 Spurious Measurement (Conducted)

Specifications:	15.209(a) and 15.205(a)					
Date of Test	2015-06-05					
Test conditions:	Ambient Temperature:15°C-35°C Relative Humidity:30%-60% Air pressure: 86-106kPa					
Operation Mode	Fix channel transmit					
Test Results:	Pass					
Test equipment Used:						
Number	Description	Manufacturer	Model Number	Serial Number	Cal Due	State
1	EMI Test Receiver	R/S	ESU40	100350	2016-03-05	Normal
2	Wireless Connectivity Test Set	R/S	CMW500	152395	2016-01-28	Normal

LIMIT

In any 100 kHz bandwidth outside the frequency band in which the spread spectrum or digitally modulated intentional radiator is operating, the radio frequency power that is produced by the intentional radiator shall be at least 20 dB below that in the 100 kHz bandwidth within the band that contains the highest level of the desired power, based on either an RF conducted or a radiated measurement. Attenuation below the general limits specified in Section 15.209(a) is not required. In addition, radiated emissions which fall in the restricted bands, as defined in Section 15.205(a), must also comply with the radiated emission limits specified in Section 15.209(a) (see Section 15.205(c)).

Test Setup

The BLUETOOTH TESTER was used to set the TX channel and power level. The transmitter output is connected to Spectrum analyzer through a coupling.

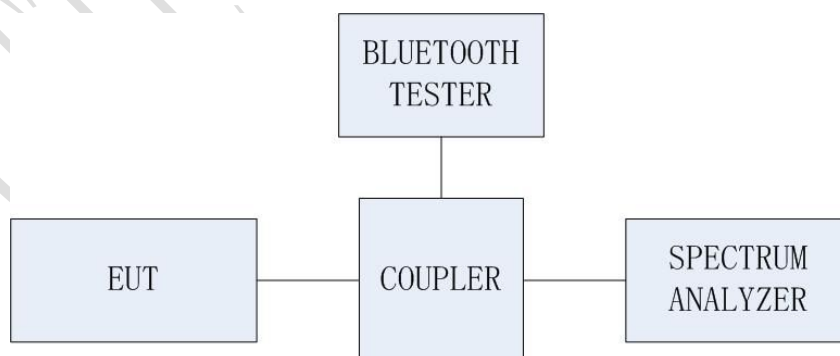

TEST PROCEDURE

Conducted RF measurements of the transmitter output were made to confirm that the EUT antenna port conducted emissions meet the specified limit and to identify any spurious signals that require further investigation or measurements on the radiated emissions site. The transmitter output is connected to the spectrum analyzer. The resolution bandwidth is set to 100 KHz. The video bandwidth is set to 300 KHz. Measurements are made over the 30 MHz to 26

GHz range with the transmitter set to the lowest, middle, and highest channels.
The measurement is made according to Public notice FCC Public Notice DA 00-705, March 2000, and ANSI C63.10-2013.

Test Result:

GFSK

Channel	Frequency Range	Results
0	Center Frequency	Pass
	30 MHz – 1 GHz	Pass
	1 GHz – 3 GHz	Pass
	3 GHz – 10 GHz	Pass
	10 GHz – 26.5 GHz	Pass
39	Center Frequency	Pass
	30 MHz – 1 GHz	Pass
	1 GHz – 3 GHz	Pass
	3 GHz – 10 GHz	Pass
	10 GHz – 26.5 GHz	Pass
78	Center Frequency	Pass
	30 MHz – 1 GHz	Pass
	1 GHz – 3 GHz	Pass
	3 GHz – 10 GHz	Pass
	10 GHz – 26.5 GHz	Pass

Pi/4 DQPSK

Channel	Frequency Range	Results
0	Center Frequency	Pass
	30 MHz – 1 GHz	Pass
	1 GHz – 3 GHz	Pass
	3 GHz – 10 GHz	Pass
	10 GHz – 26.5 GHz	Pass
39	Center Frequency	Pass
	30 MHz – 1 GHz	Pass

	1 GHz – 3 GHz	Pass
	3 GHz – 10 GHz	Pass
	10 GHz – 26.5 GHz	Pass
78	Center Frequency	Pass
	30 MHz – 1 GHz	Pass
	1 GHz – 3 GHz	Pass
	3 GHz – 10 GHz	Pass
	10 GHz – 26.5 GHz	Pass

8DPSK

Channel	Frequency Range	Results
0	Center Frequency	Pass
	30 MHz – 1 GHz	Pass
	1 GHz – 3 GHz	Pass
	3 GHz – 10 GHz	Pass
	10 GHz – 26.5 GHz	Pass
39	Center Frequency	Pass
	30 MHz – 1 GHz	Pass
	1 GHz – 3 GHz	Pass
	3 GHz – 10 GHz	Pass
	10 GHz – 26.5 GHz	Pass
78	Center Frequency	Pass
	30 MHz – 1 GHz	Pass
	1 GHz – 3 GHz	Pass
	3 GHz – 10 GHz	Pass
	10 GHz – 26.5 GHz	Pass

FCC Parts 15 subpart C, ANSI C63.10-2013, FCC DA 00-705
Equipment: U100

REPORT NO.:B15X50225-FCC-BT

Test plots:
GFSK Channel 0

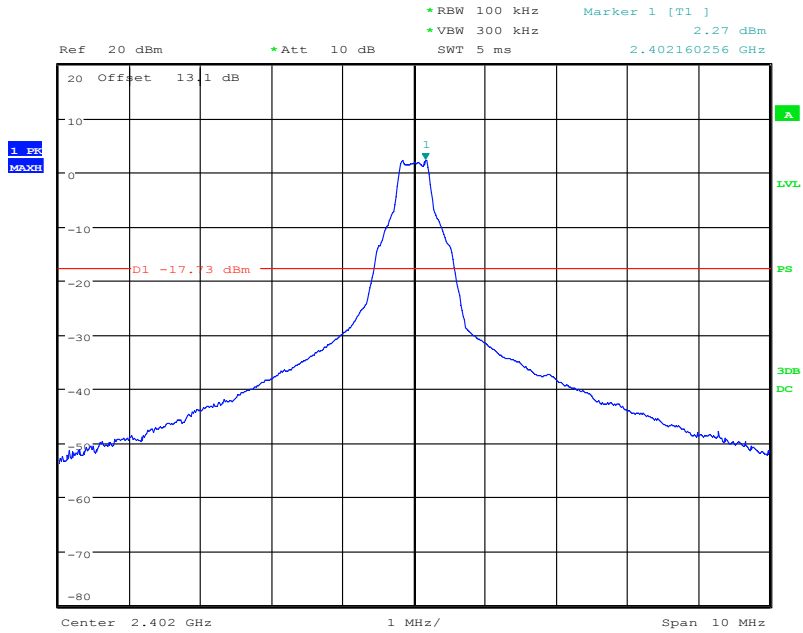

Date: 5.JUN.2015 14:53:03

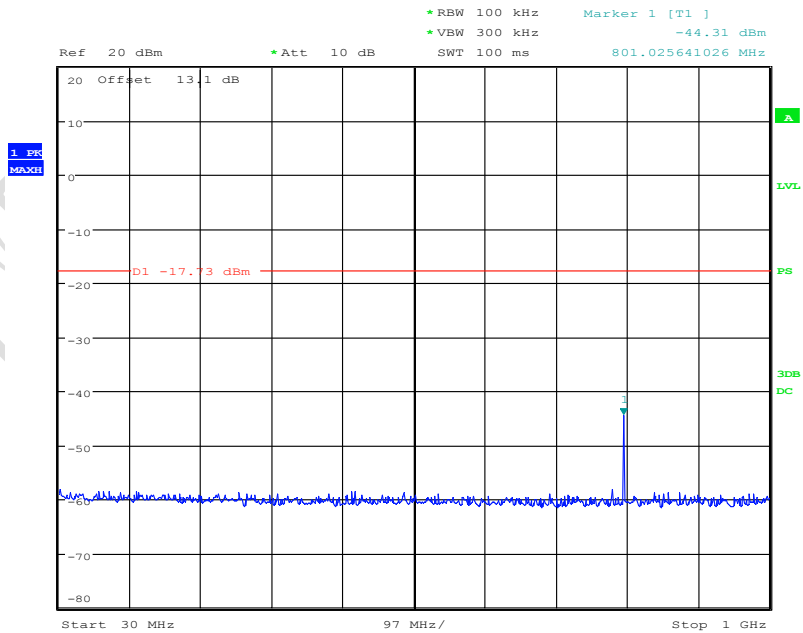

Date: 5.JUN.2015 14:54:01

FCC Parts 15 subpart C, ANSI C63.10-2013, FCC DA 00-705
Equipment: U100

REPORT NO.:B15X50225-FCC-BT

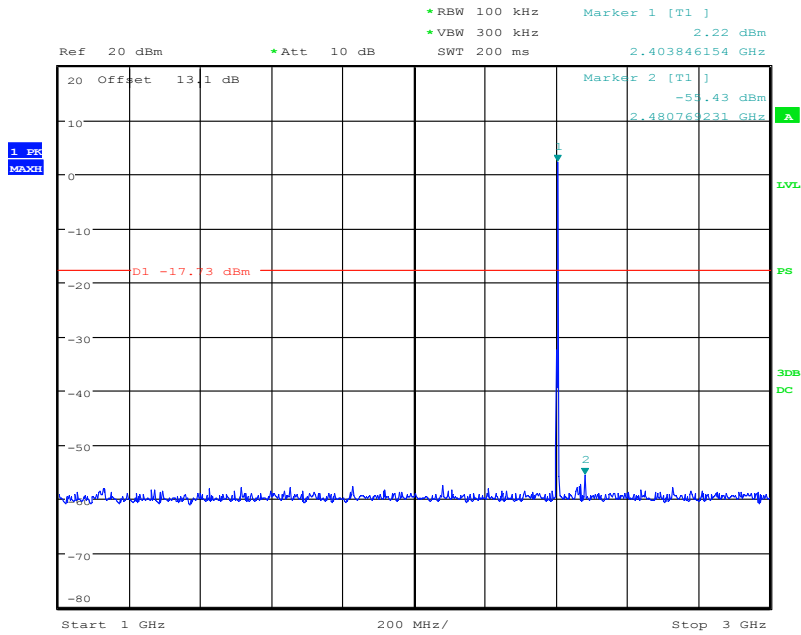

Date: 5.JUN.2015 14:55:13

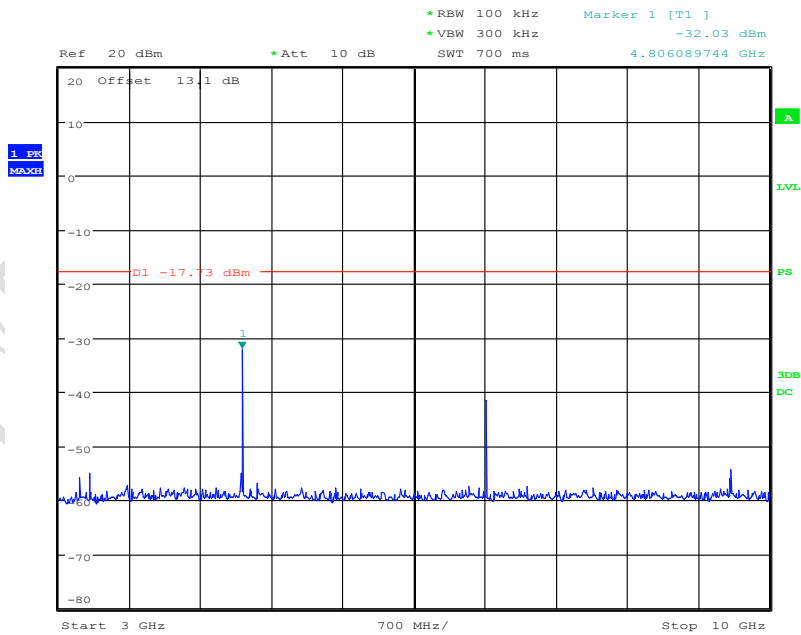

Date: 5.JUN.2015 14:56:03

FCC Parts 15 subpart C, ANSI C63.10-2013, FCC DA 00-705
Equipment: U100

REPORT NO.:B15X50225-FCC-BT

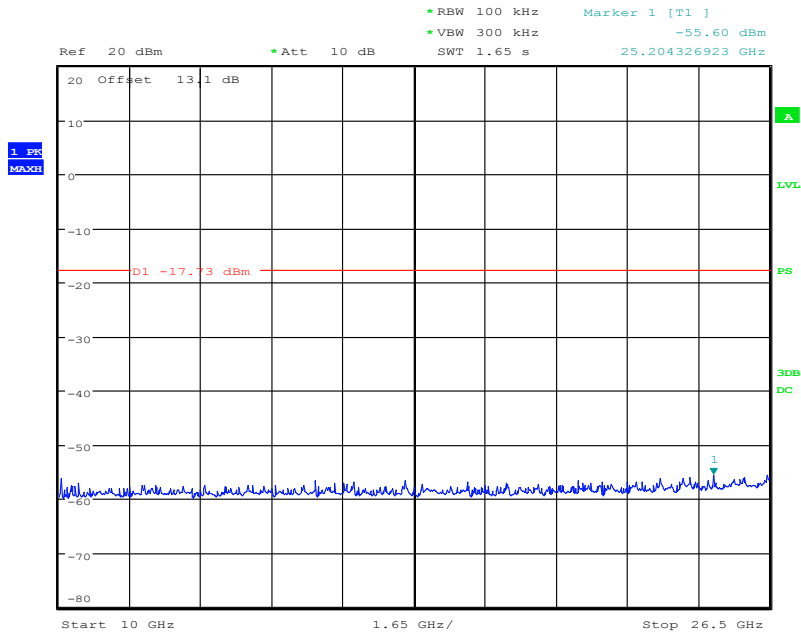

Date: 5.JUN.2015 14:56:52

GFSK Channel 39

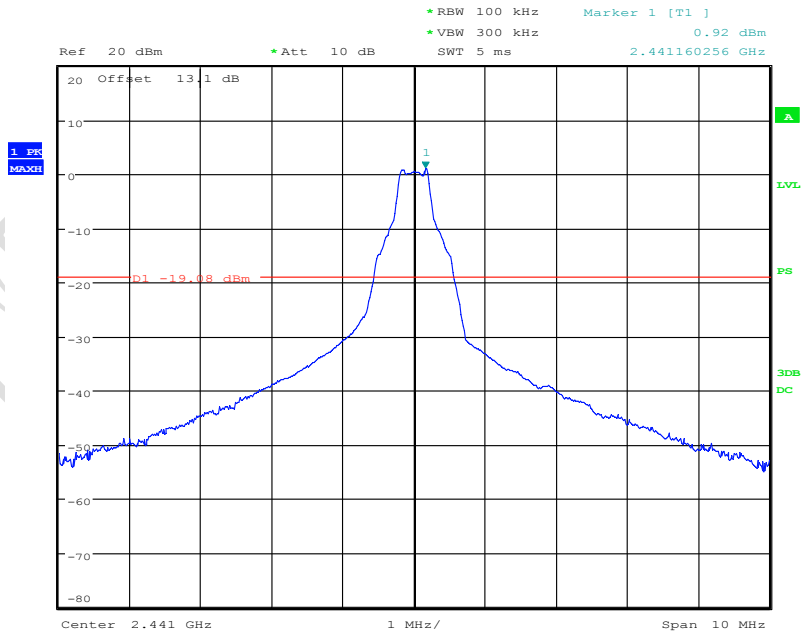

Date: 5.JUN.2015 14:59:01

FCC Parts 15 subpart C, ANSI C63.10-2013, FCC DA 00-705
Equipment: U100

REPORT NO.:B15X50225-FCC-BT

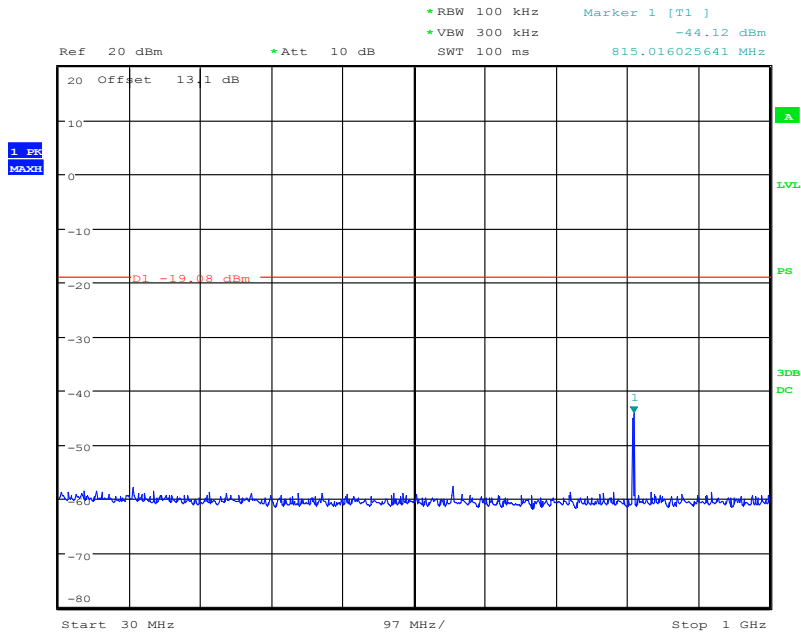

Date: 5.JUN.2015 15:00:19

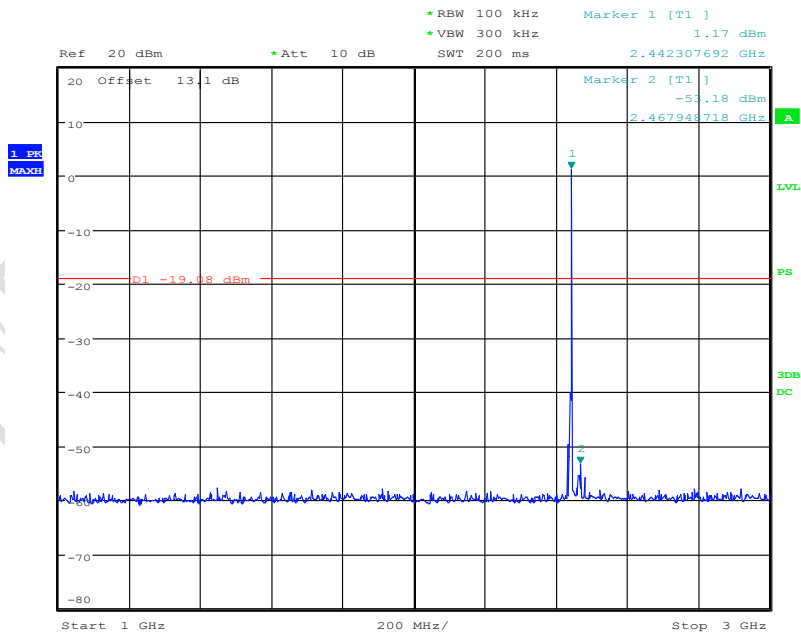

Date: 5.JUN.2015 15:01:46

FCC Parts 15 subpart C, ANSI C63.10-2013, FCC DA 00-705
Equipment: U100

REPORT NO.:B15X50225-FCC-BT

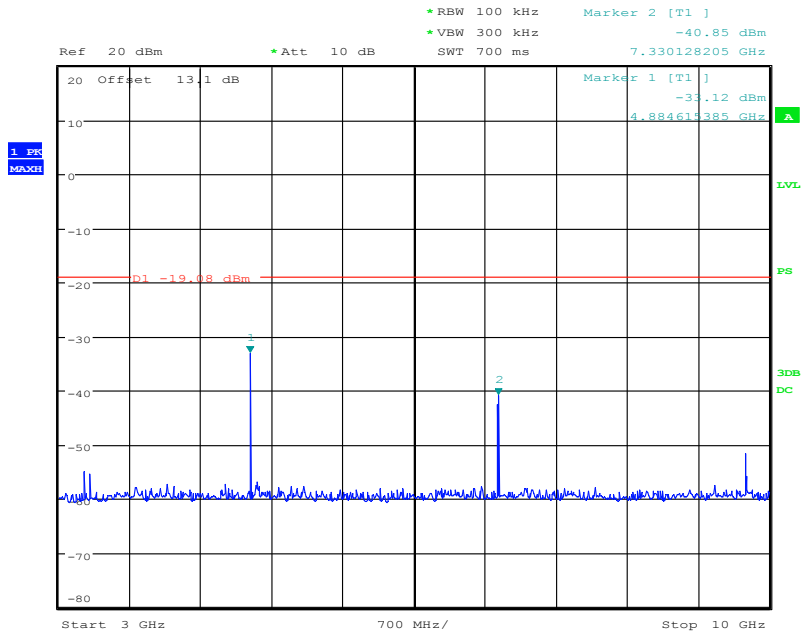

Date: 5.JUN.2015 15:02:19

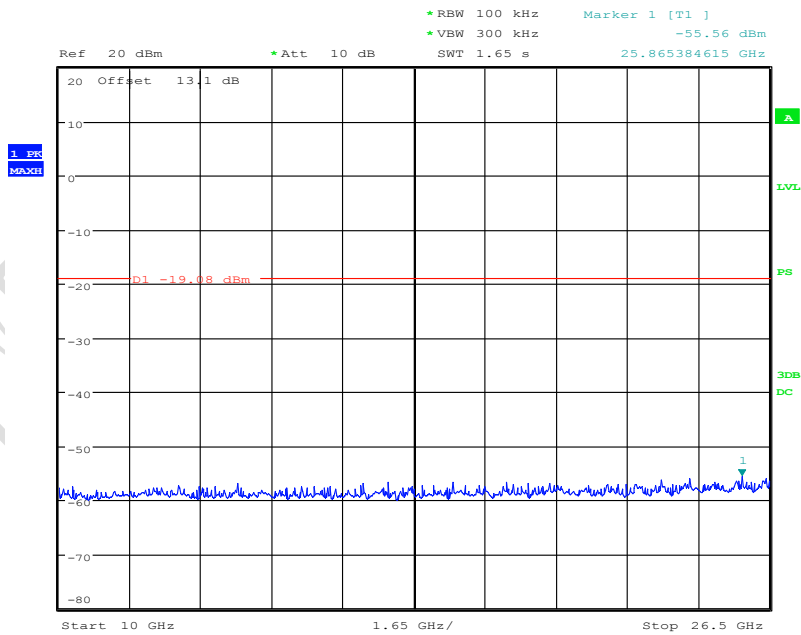

Date: 5.JUN.2015 15:03:18

FCC Parts 15 subpart C, ANSI C63.10-2013, FCC DA 00-705
Equipment: U100

REPORT NO.:B15X50225-FCC-BT

GFSK Channel 78

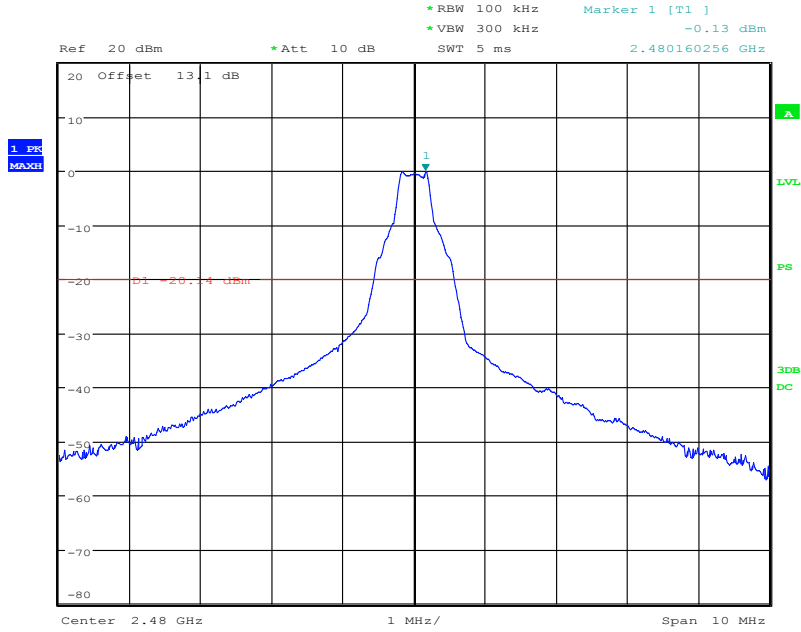

Date: 5.JUN.2015 15:05:22

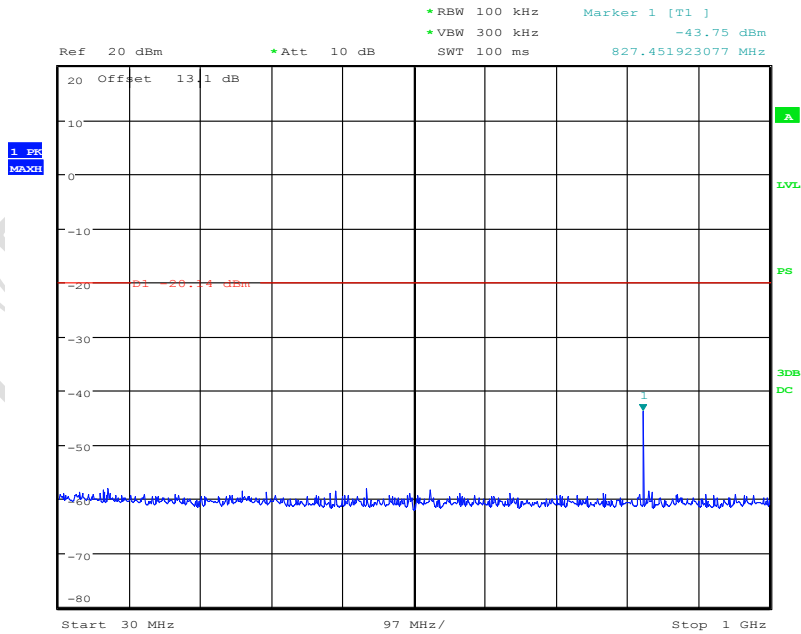

Date: 5.JUN.2015 15:05:46

FCC Parts 15 subpart C, ANSI C63.10-2013, FCC DA 00-705
Equipment: U100

REPORT NO.:B15X50225-FCC-BT

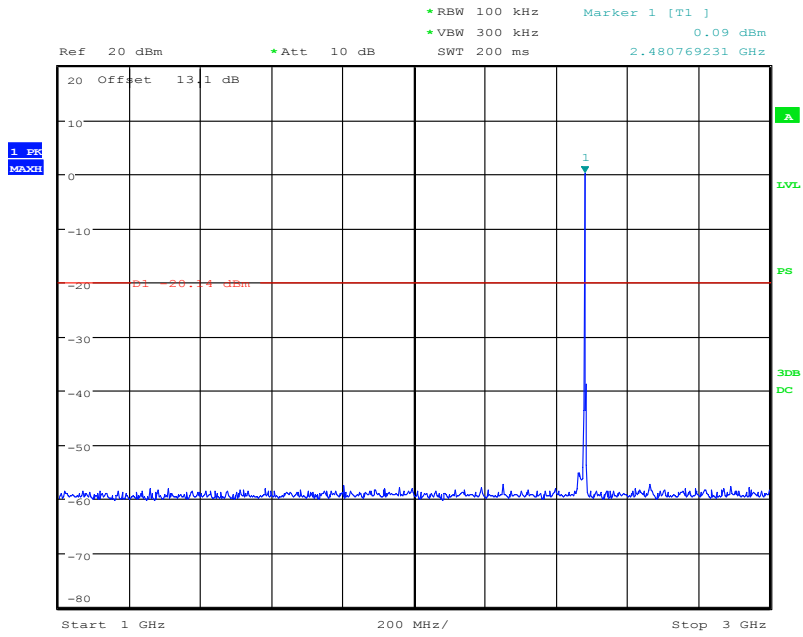

Date: 5.JUN.2015 15:07:56

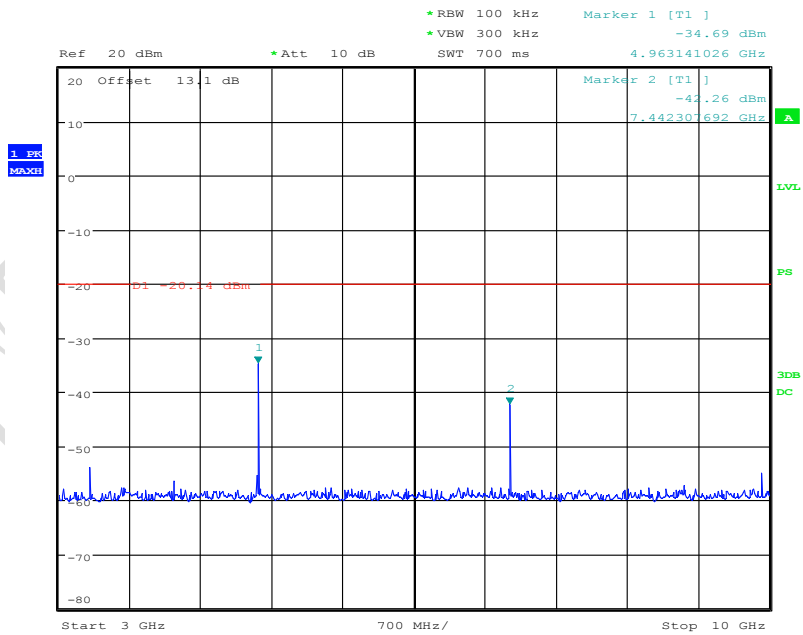

Date: 5.JUN.2015 15:08:41

FCC Parts 15 subpart C, ANSI C63.10-2013, FCC DA 00-705
Equipment: U100

REPORT NO.:B15X50225-FCC-BT

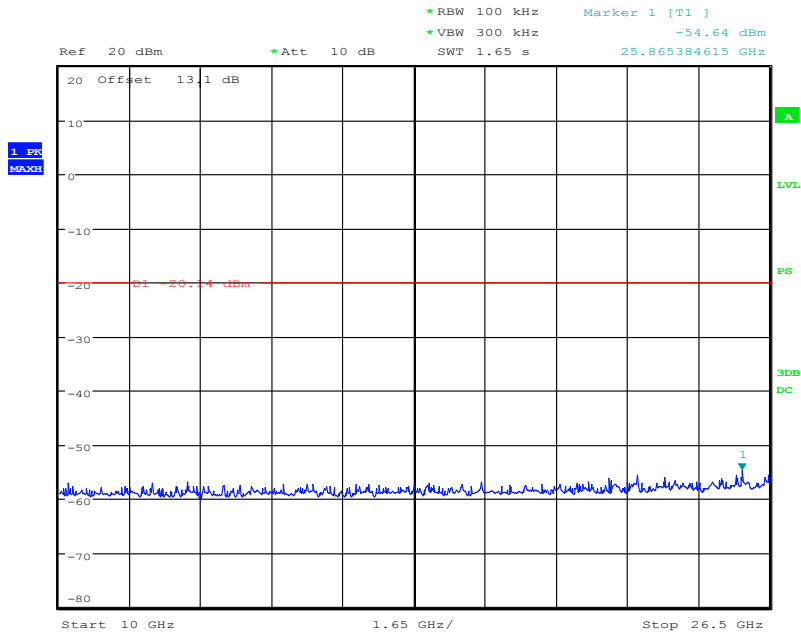

Date: 5.JUN.2015 15:09:46

Pi/4 DQPSK Channel 0

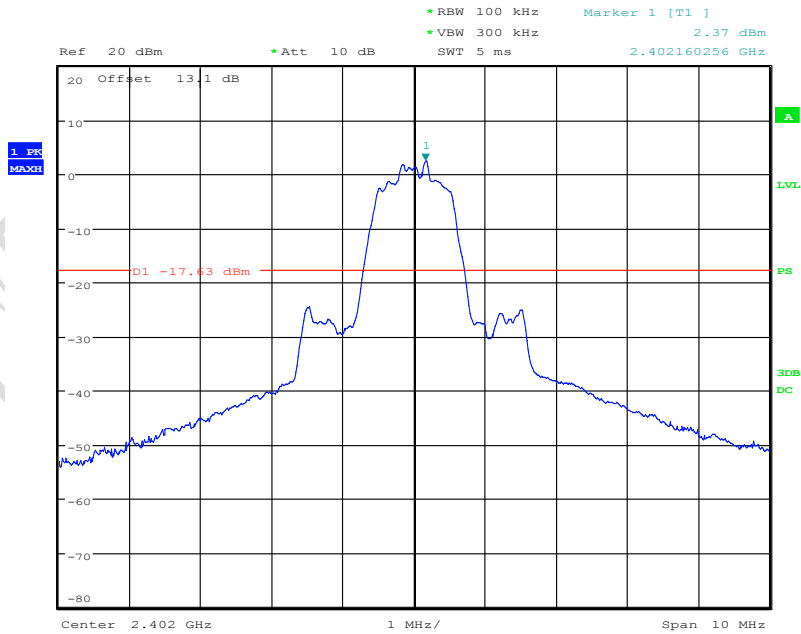

Date: 5.JUN.2015 15:13:17

FCC Parts 15 subpart C, ANSI C63.10-2013, FCC DA 00-705
Equipment: U100

REPORT NO.:B15X50225-FCC-BT

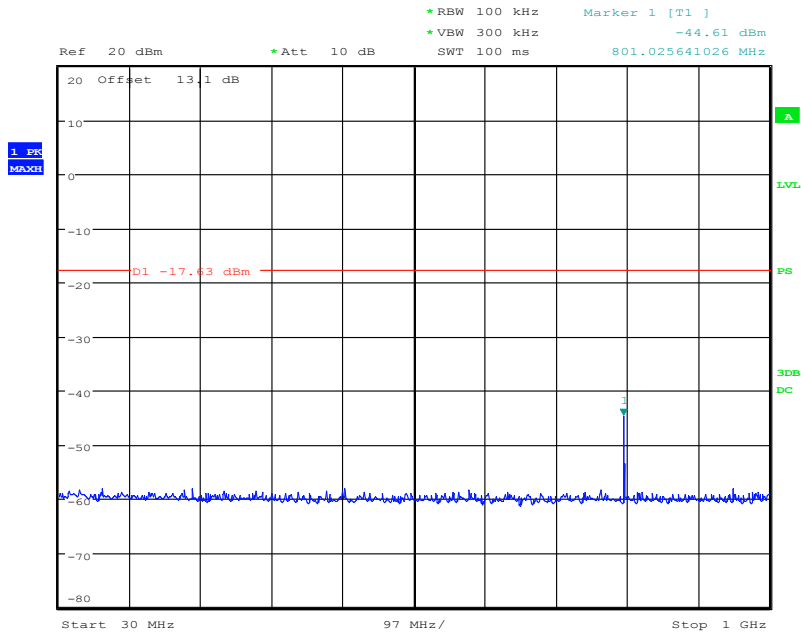

Date: 5.JUN.2015 15:14:28

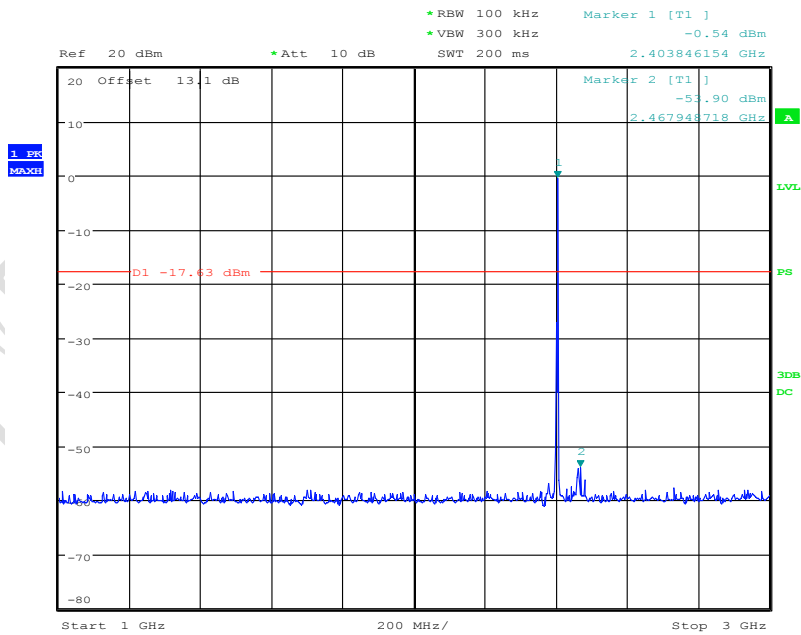

Date: 5.JUN.2015 15:15:11

FCC Parts 15 subpart C, ANSI C63.10-2013, FCC DA 00-705
Equipment: U100

REPORT NO.:B15X50225-FCC-BT

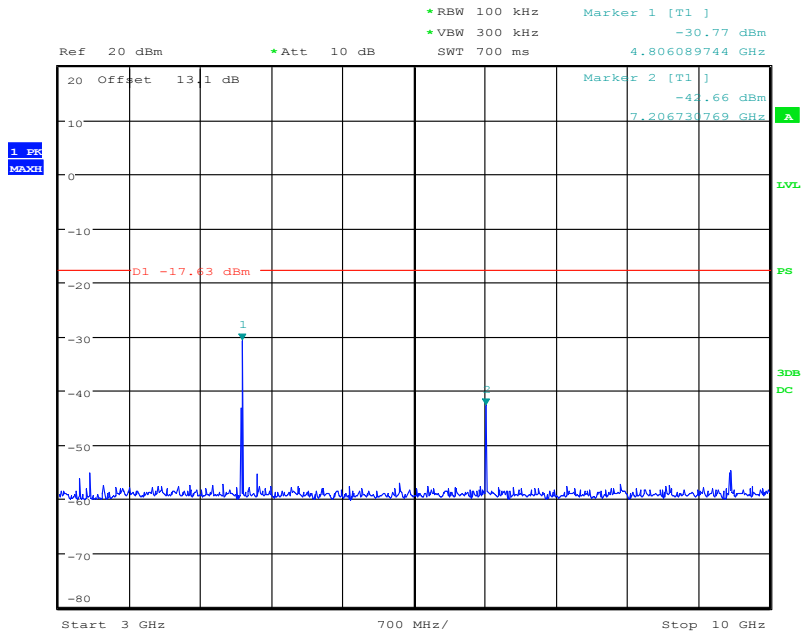

Date: 5.JUN.2015 15:16:14

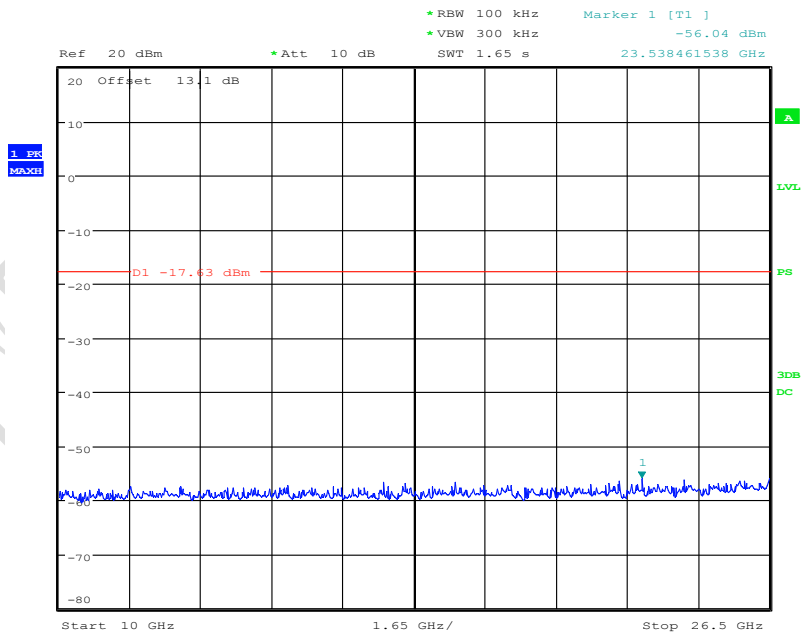

Date: 5.JUN.2015 15:16:40

Pi/4 DQPSK Channel 39

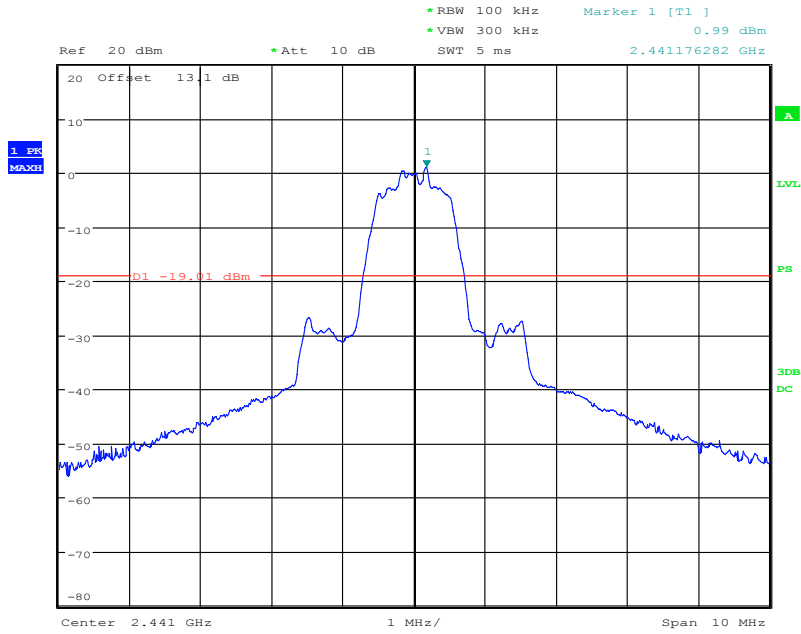

Date: 5.JUN.2015 15:18:03

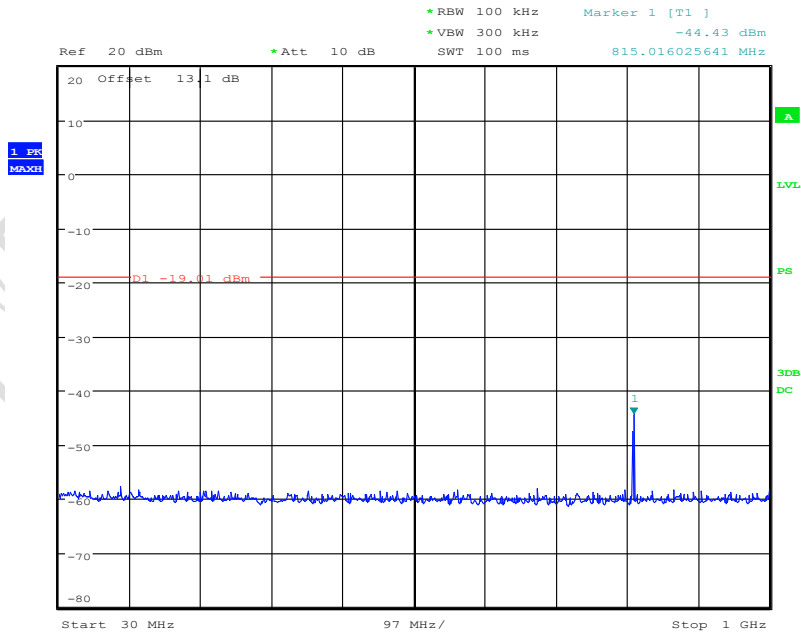

Date: 5.JUN.2015 15:19:03

FCC Parts 15 subpart C, ANSI C63.10-2013, FCC DA 00-705
Equipment: U100

REPORT NO.:B15X50225-FCC-BT

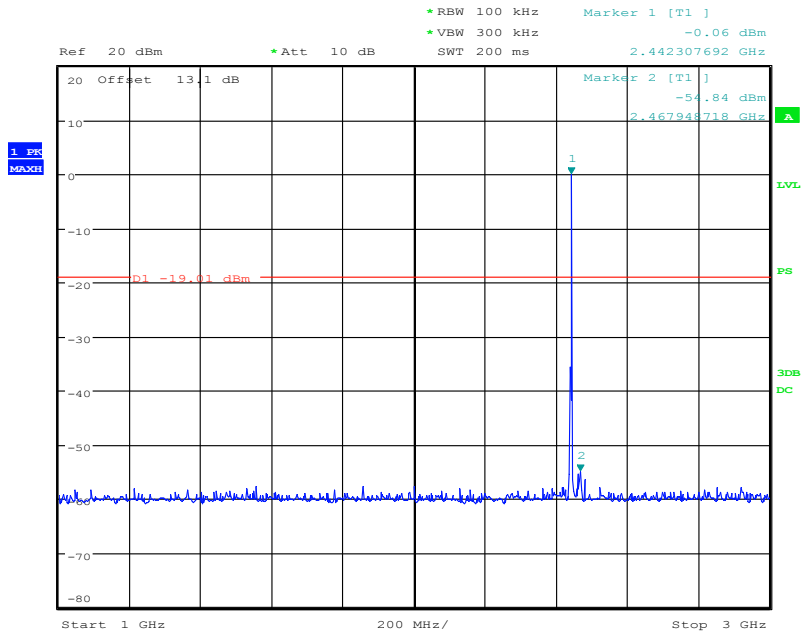

Date: 5.JUN.2015 15:19:41

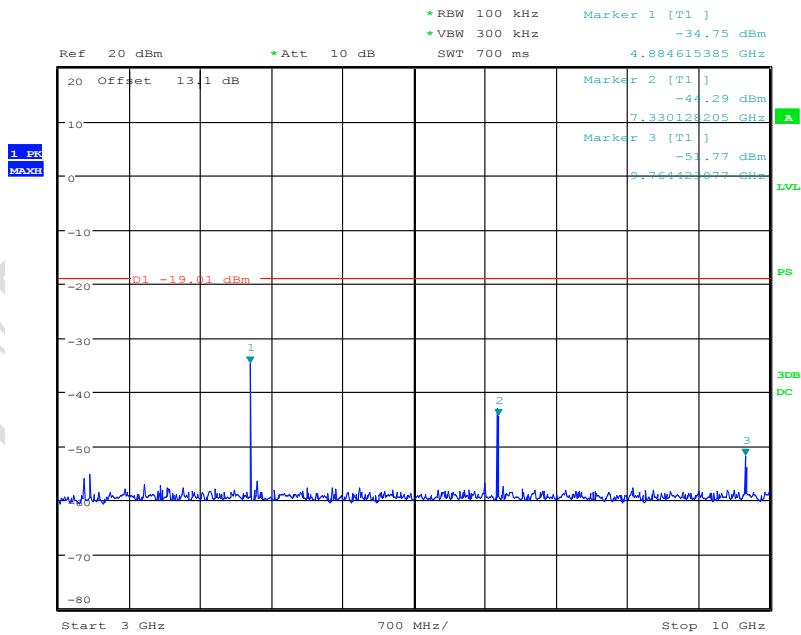

Date: 5.JUN.2015 15:20:13

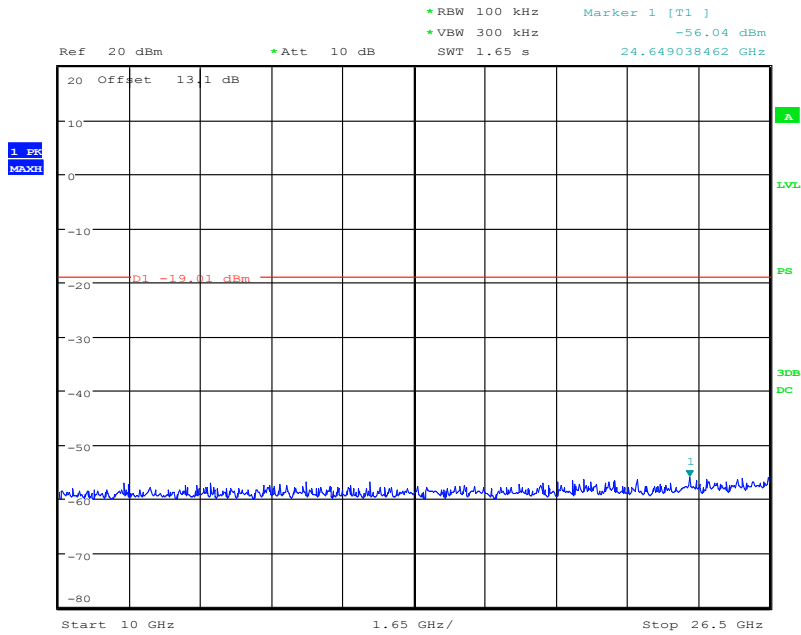

Date: 5.JUN.2015 15:20:47

Pi/4 DQPSK Channel 78

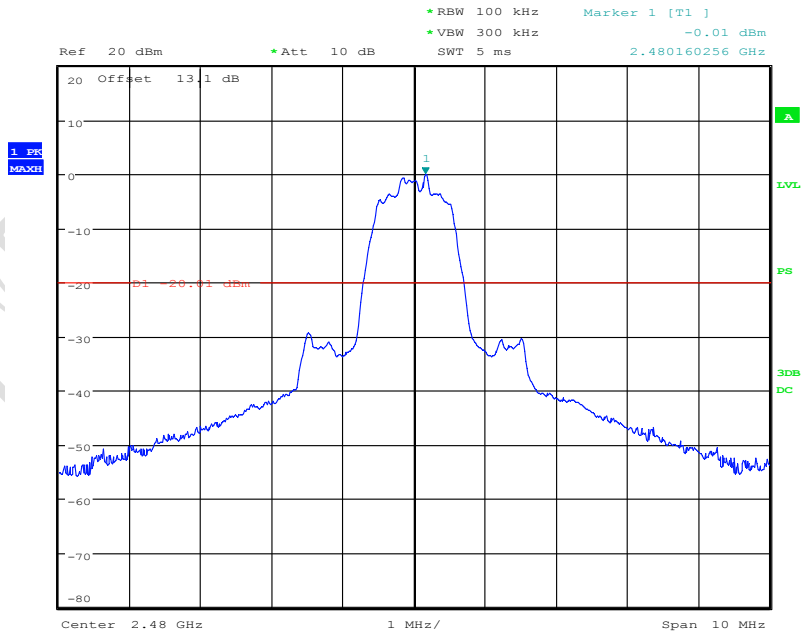

Date: 5.JUN.2015 15:22:33

FCC Parts 15 subpart C, ANSI C63.10-2013, FCC DA 00-705
Equipment: U100

REPORT NO.:B15X50225-FCC-BT

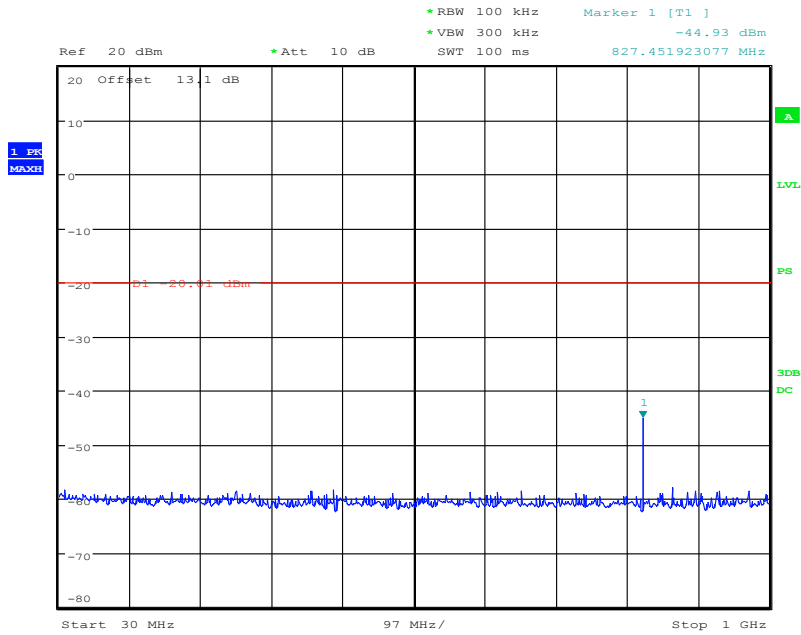

Date: 5.JUN.2015 15:22:54

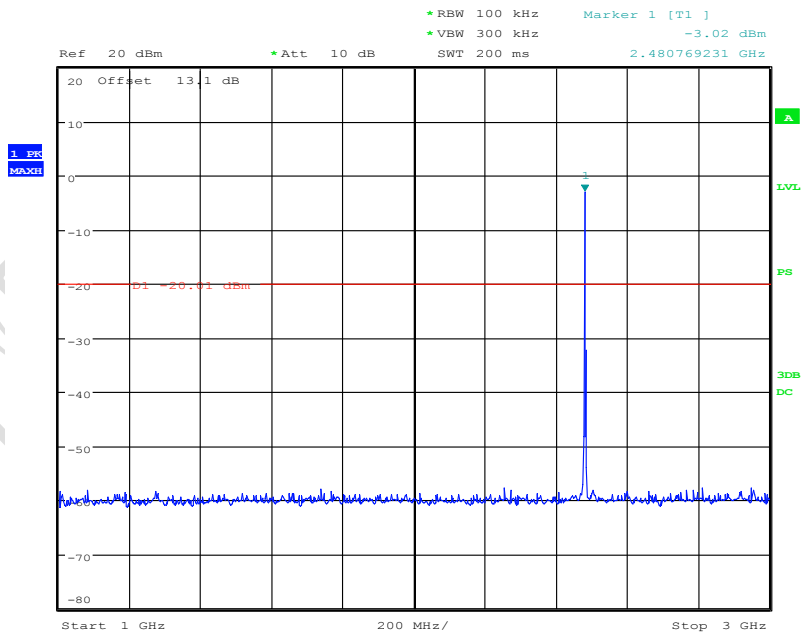

Date: 5.JUN.2015 15:23:24

FCC Parts 15 subpart C, ANSI C63.10-2013, FCC DA 00-705
Equipment: U100

REPORT NO.:B15X50225-FCC-BT

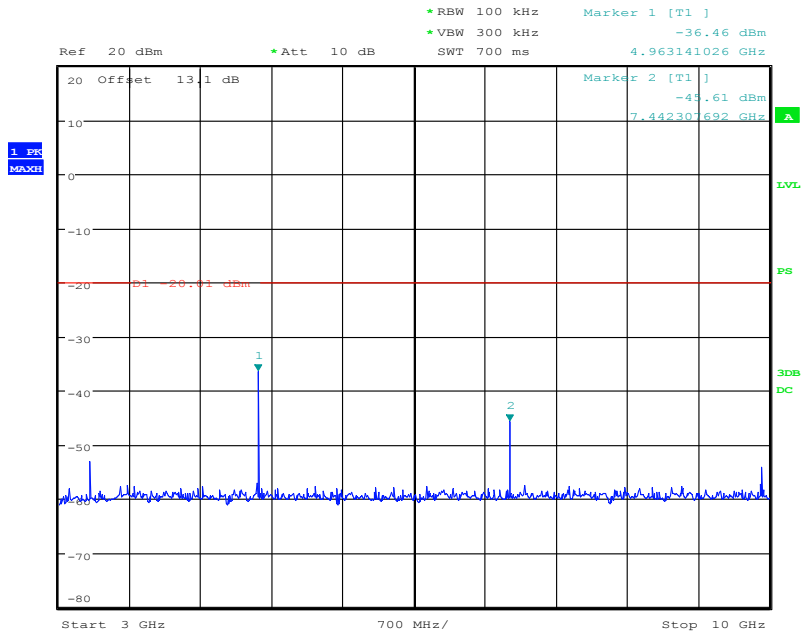

Date: 5.JUN.2015 15:23:52

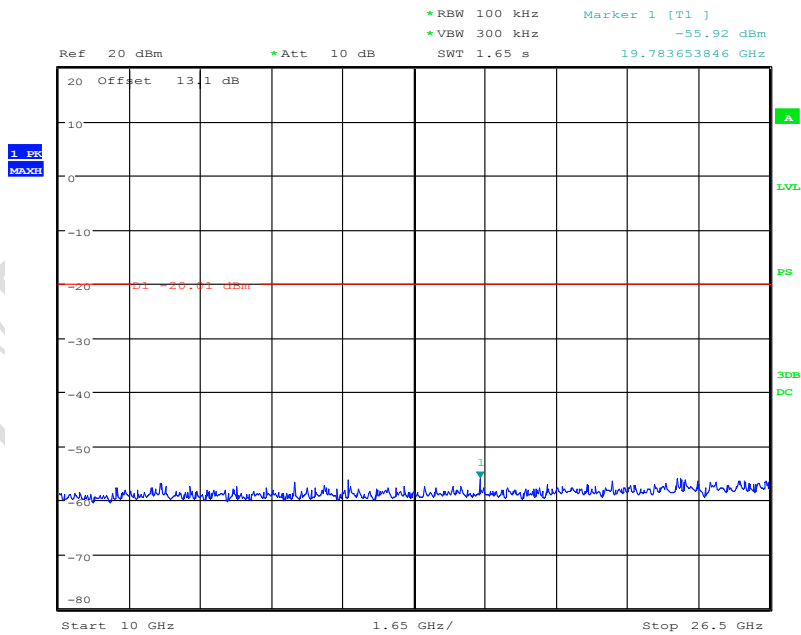

Date: 5.JUN.2015 15:24:18

8DPSK Channel 0

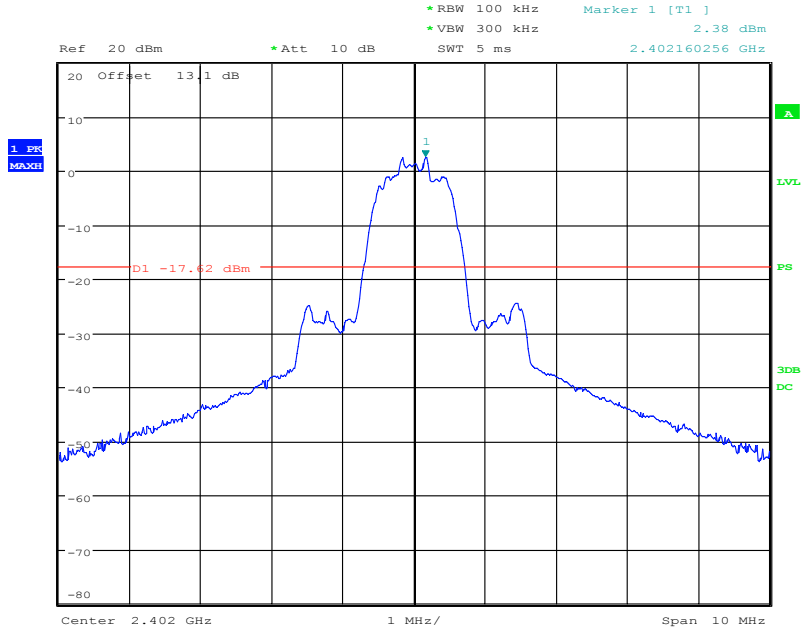

Date: 5.JUN.2015 15:26:12

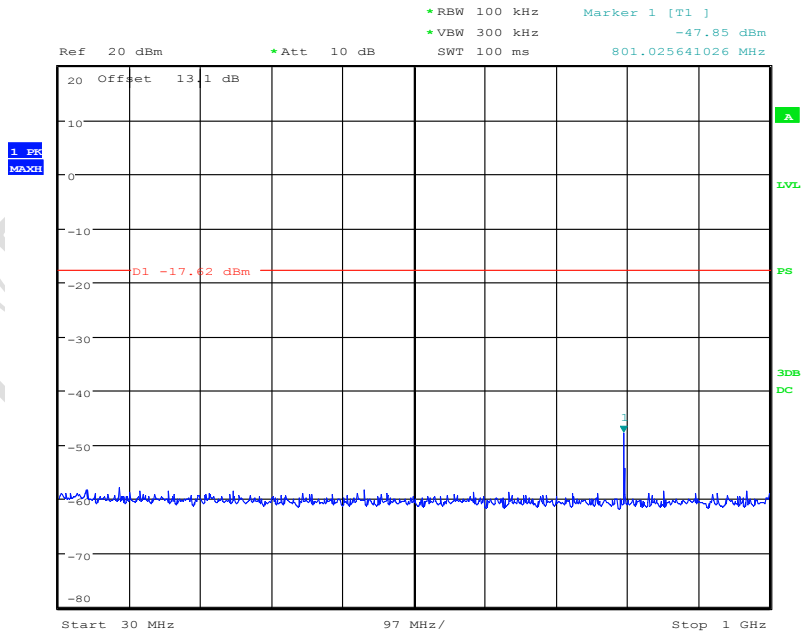

Date: 5.JUN.2015 15:26:39

FCC Parts 15 subpart C, ANSI C63.10-2013, FCC DA 00-705
Equipment: U100

REPORT NO.:B15X50225-FCC-BT

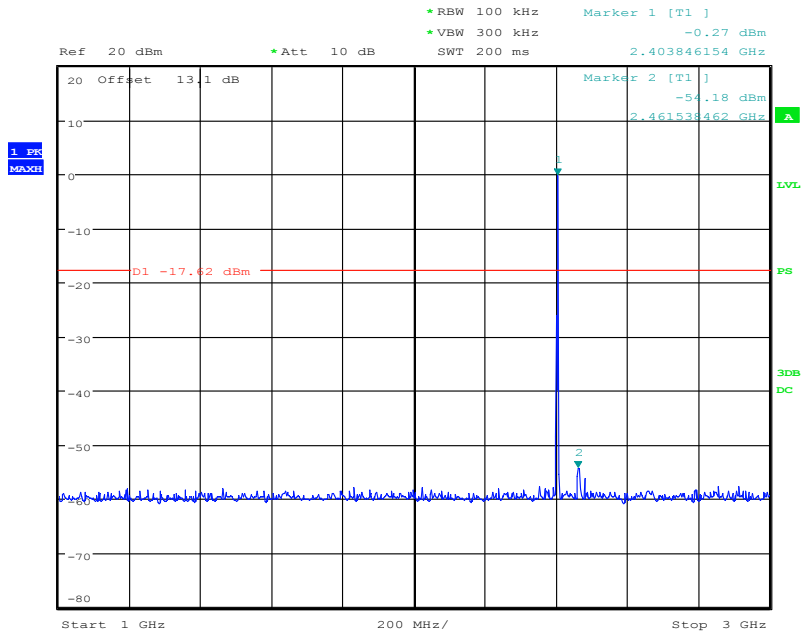

Date: 5.JUN.2015 15:27:29

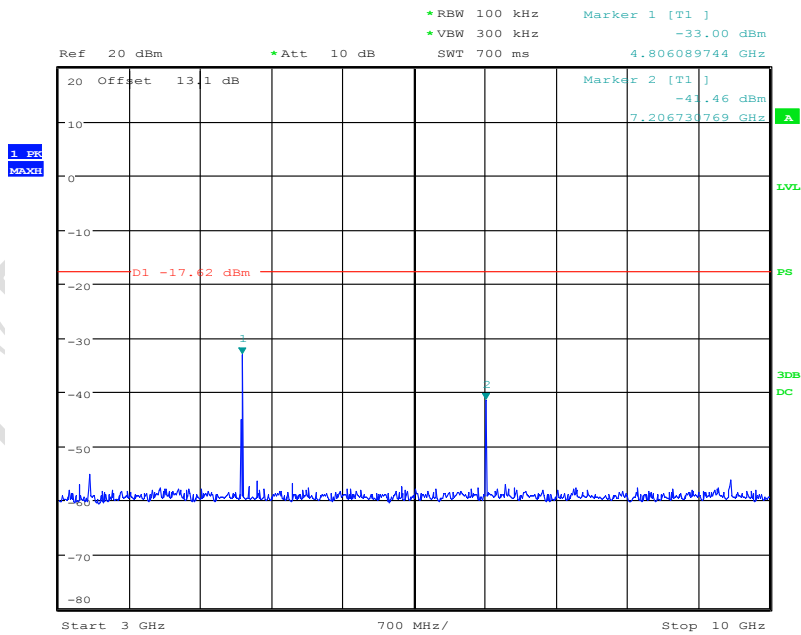

Date: 5.JUN.2015 15:28:07

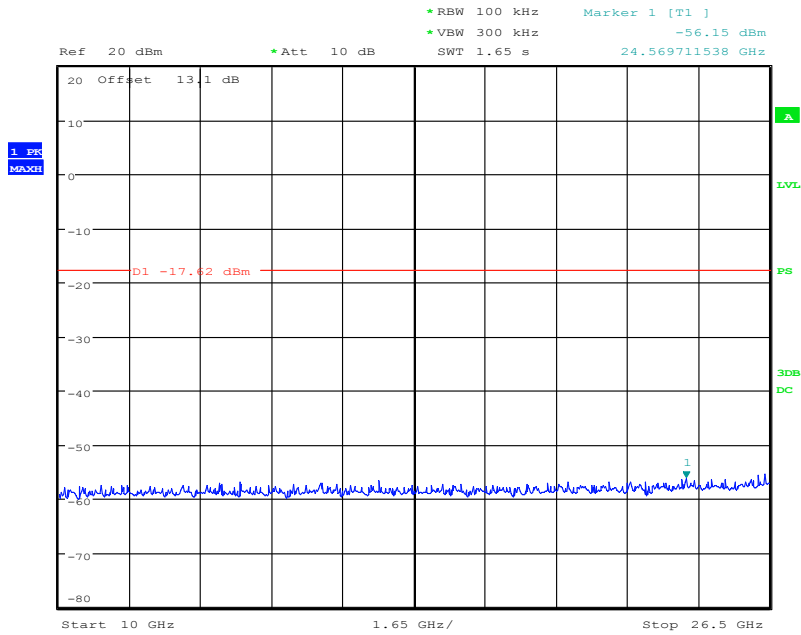

Date: 5.JUN.2015 15:28:44

8DPSK Channel 39

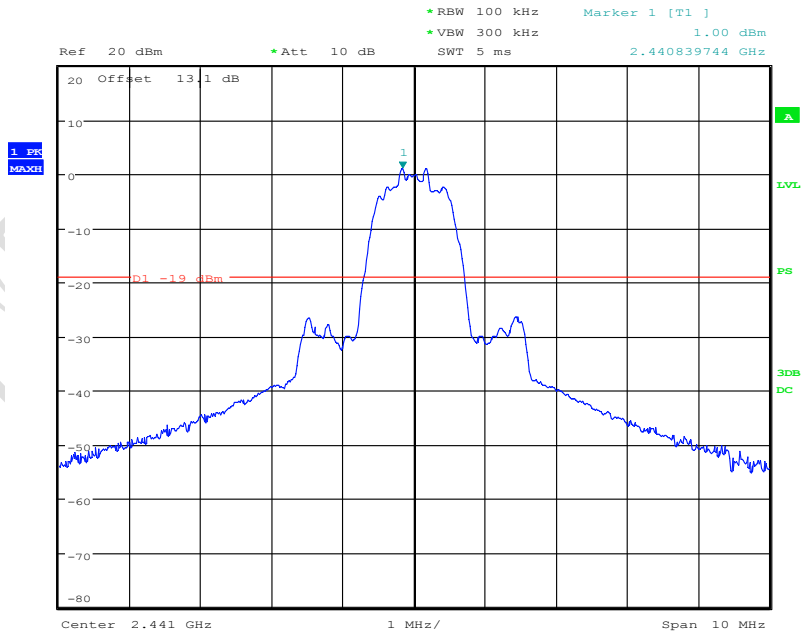

Date: 5.JUN.2015 15:30:22

FCC Parts 15 subpart C, ANSI C63.10-2013, FCC DA 00-705
Equipment: U100

REPORT NO.:B15X50225-FCC-BT

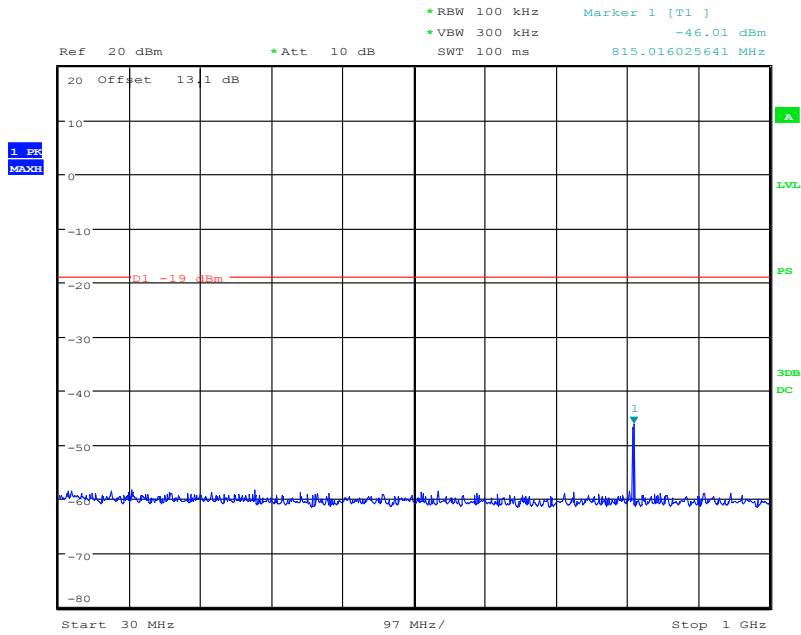

Date: 5.JUN.2015 15:30:54

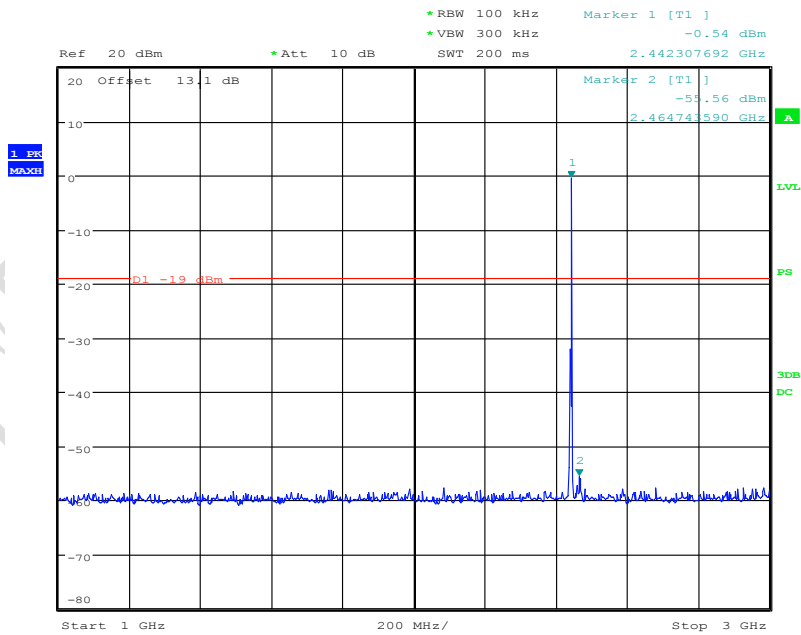

Date: 5.JUN.2015 15:31:42

FCC Parts 15 subpart C, ANSI C63.10-2013, FCC DA 00-705
Equipment: U100

REPORT NO.:B15X50225-FCC-BT

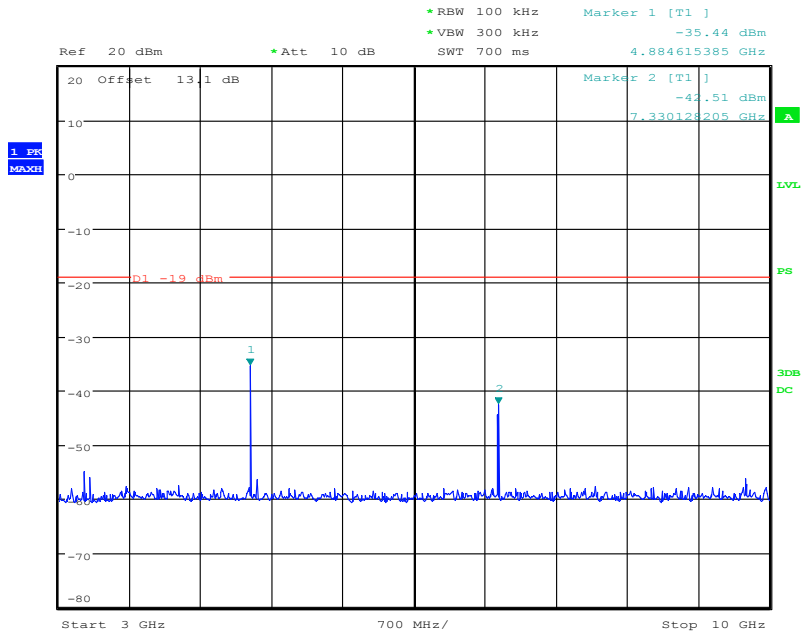

Date: 5.JUN.2015 15:32:11

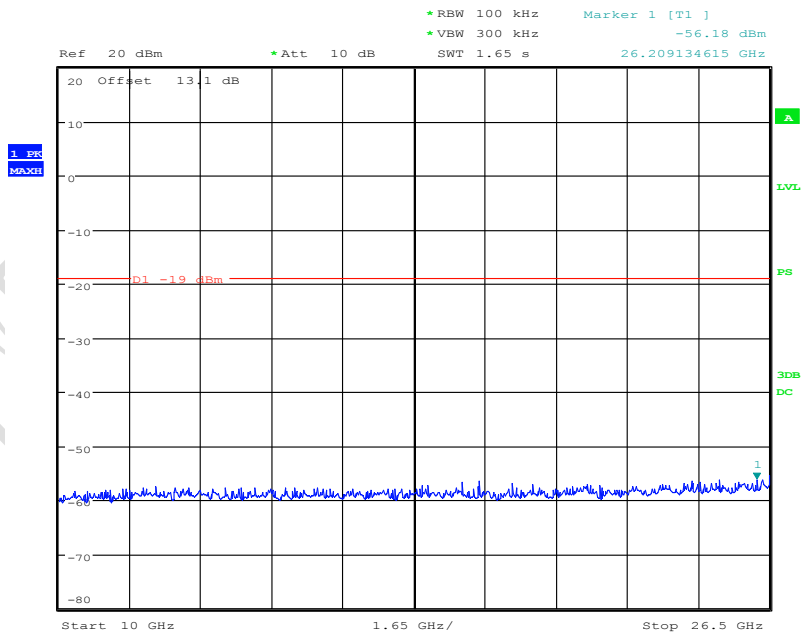

Date: 5.JUN.2015 15:32:38

8DPSK Channel 78

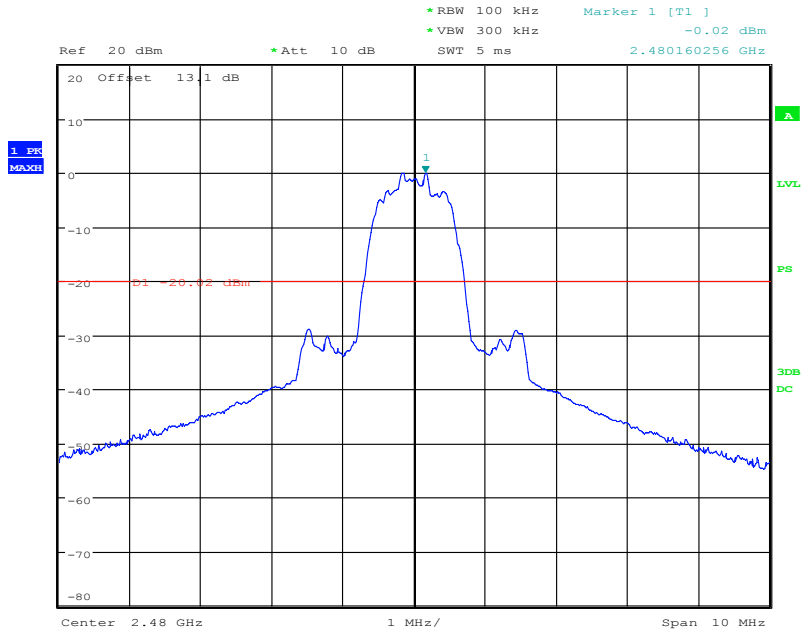

Date: 5.JUN.2015 15:56:49

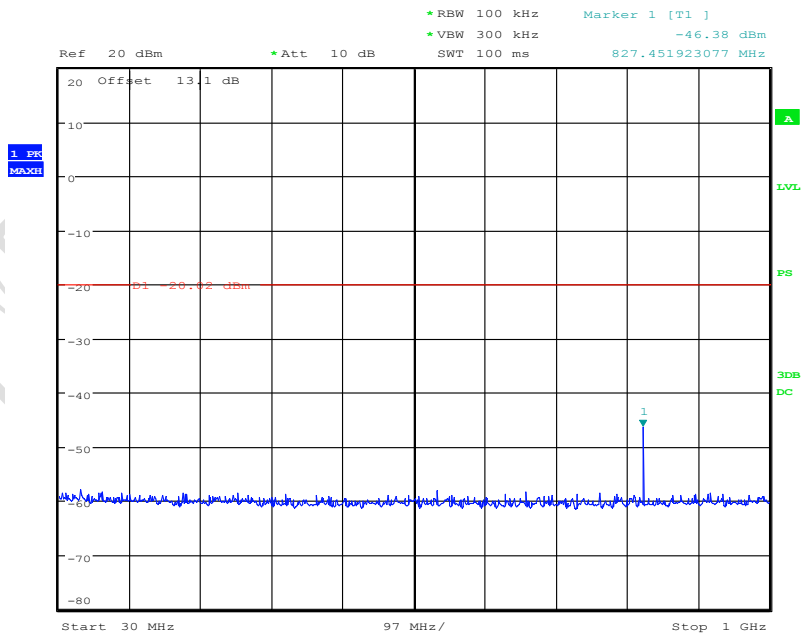

Date: 5.JUN.2015 15:57:34

FCC Parts 15 subpart C, ANSI C63.10-2013, FCC DA 00-705
Equipment: U100

REPORT NO.:B15X50225-FCC-BT

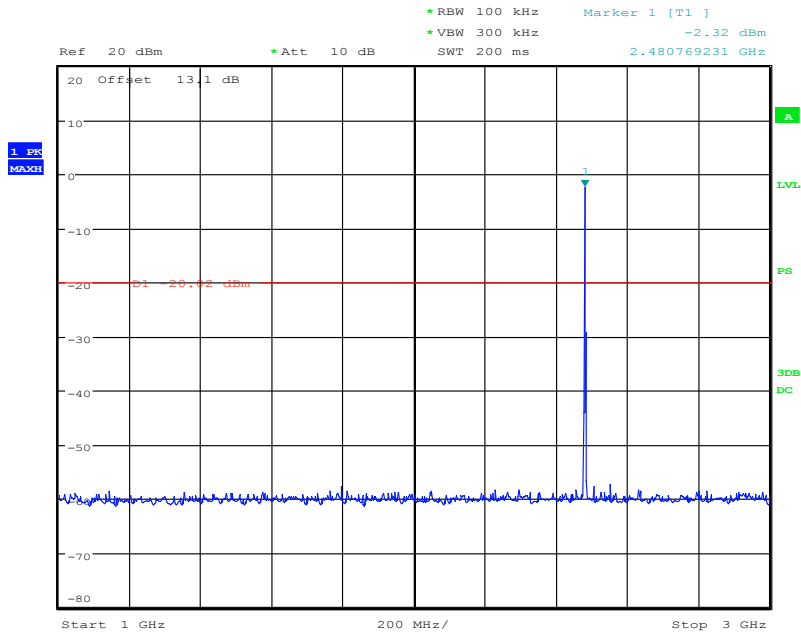

Date: 5.JUN.2015 15:57:59

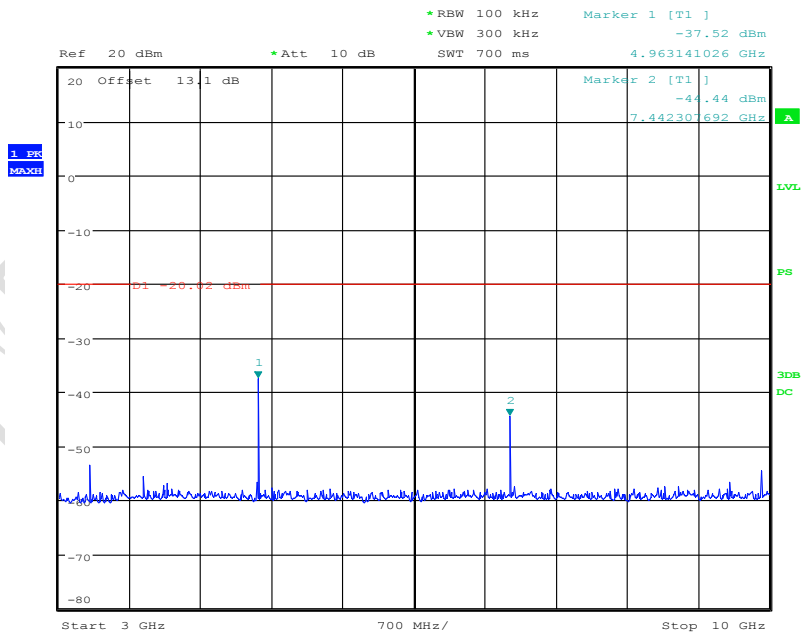

Date: 5.JUN.2015 15:58:41

FCC Parts 15 subpart C, ANSI C63.10-2013, FCC DA 00-705
Equipment: U100

REPORT NO.:B15X50225-FCC-BT

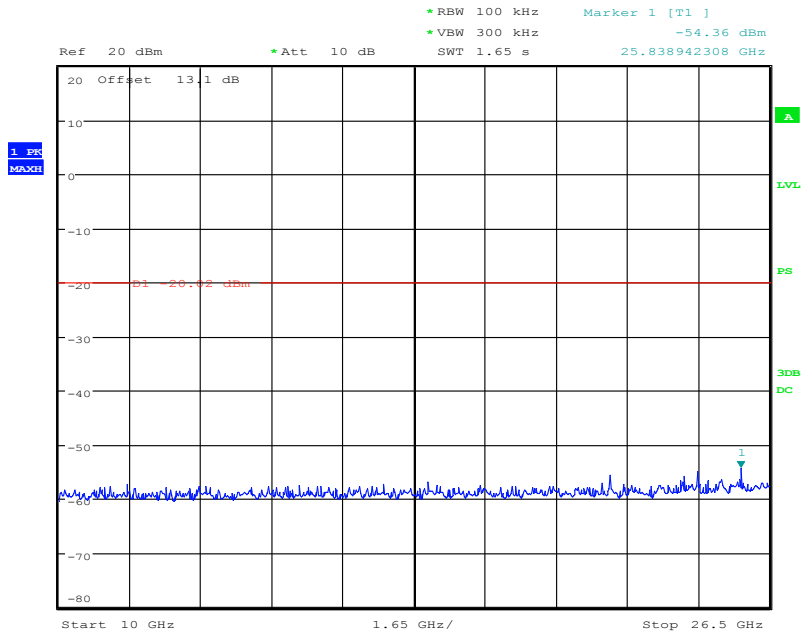

Date: 5.JUN.2015 15:59:01

CTTL TEST 11

4.7 Radiated Emission Measurement

Specifications:	15.209(a) and 15.205(a)					
Date of Test	2015-06-04					
Test conditions:	Ambient Temperature: 15°C-35°C Relative Humidity: 30%-60% Air pressure: 86-106kPa					
Operation Mode	Fix channel transmit					
Test Results:	Pass					
Test equipment Used:						
Number	Description	Manufacturer	Model Number	Serial Number	Cal Due	State
1	EMI Test Receiver	R&S	ESU26	100367	2016-03-05	Normal
2	Fully-Anechoic Chamber	ETS	FACT3-2	--	2015-08-20	Normal
3	Wireless Connectivity Test Set	R/S	CMW500	152395	2016-01-28	Normal
4	Ultra Broadband Antenna	R/S	VULB 9163	vulb9163-544	2015-12-13	Normal
5	Double-Ridged Horn Antenna	R/S	HF907	100357	2015-12-13	Normal

Limit:

1. 20dBc in any 100 kHz bandwidth outside the operating frequency band. In case the emission fall within the restricted band specified on 15.205(a), then the 15.209(a) limit in the table below has to be followed

Frequency (MHz)	Field Strength (uV/m)	Measurement Distance (m)
1.705-30	30	30
30-88	100	3
88-216	150	3
216-960	200	3
Above 960	500	3

Test Setup

The EUT was placed in an anechoic chamber. The BLUETOOTH TESTER was used to set the TX channel and power level. The transmitter output is connected to Spectrum analyzer through a Bilog antenna (for frequency 30MHz-1GHz) or a horn antenna (for frequency above 1GHz).

30MHz-1GHz:

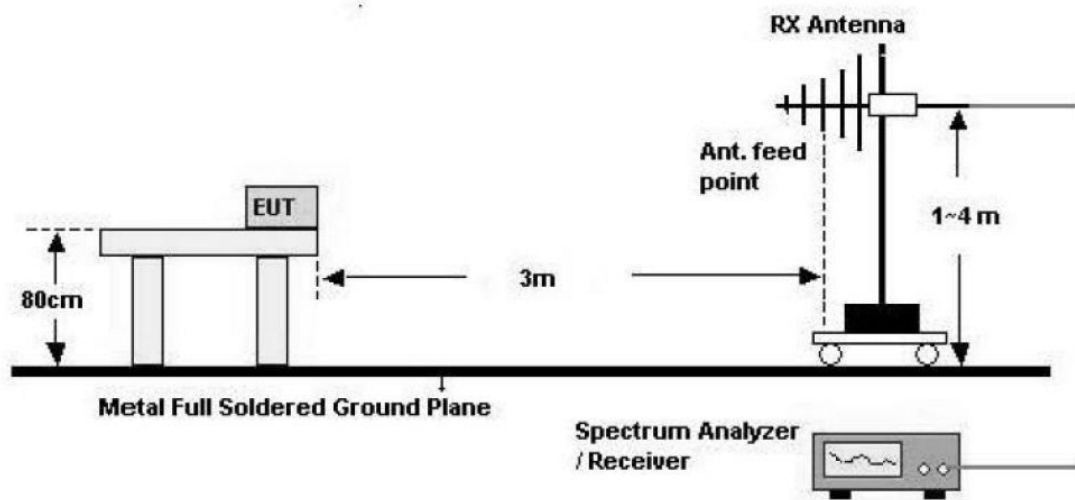

Above 1GHz:

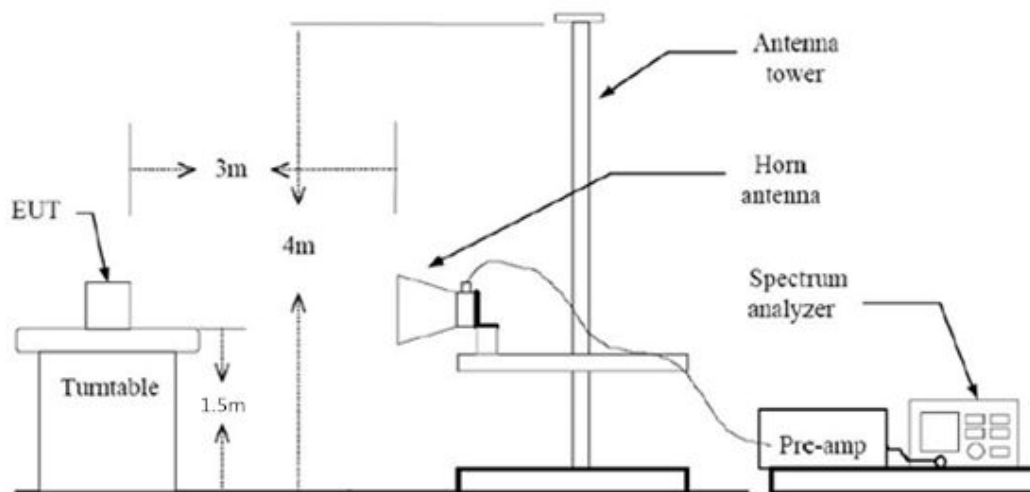

TEST PROCEDURE

1. The EUT is placed on a turntable.
2. The turntable shall be rotated for 360 degrees on EUT's x, y and z axis to determine the position of maximum emission level.
3. EUT is set 3 m away from the receiving antenna, which is varied from 1m to 4m to find out the highest emissions.
4. Maximum procedure was performed on the six highest emissions to ensure EUT compliance.
5. And also, each emission was to be maximized by changing the polarization of receiving antenna both horizontal and vertical.
6. Repeat above procedures until the measurements for all frequencies are complete.

The measurement is made according to Public notice FCC Public Notice DA 00-705, March 2000, and ANSI C63.4-2014.

Test Settings:

Frequency Range (MHz)	RBW/VBW	Sweep time (s)
30 – 1000	100kHz/300kHz	5
1000 – 4000	1MHz/3MHz	15
4000 – 18000	1MHz/3MHz	40
18000 – 26500	1MHz/3MHz	20

Note: Considering the GFSK modulation with packet type DH5 has the maximum transmission power, so only this mode is tested.

Test result:

Channel	Frequency Range	Results
Channel 0	30MHz – 1GHz	Pass
	1 GHz – 3GHz	Pass
	2.38GHz-2.45GHz*	Pass
	3 GHz – 18 GHz	Pass
Channel 39	30MHz – 1GHz	Pass
	1 GHz – 3GHz	Pass
	2.4GHz-2.48GHz*	Pass
	3 GHz – 18 GHz	Pass
Channel 78	30MHz – 1GHz	Pass
	1 GHz – 3GHz	Pass
	2.45GHz-2.5GHz*	Pass
	3 GHz – 18 GHz	Pass
All channels	18GHz-26.5GHz	Pass

Note*: these tests demonstrate the radiated band-edge test results

Channel 0:

Frequency (MHz)	QuasiPeak (dB μ V/m)	Bandwidth (kHz)	Height (cm)	Polarization	Azimuth (deg)	Margin (dB)	Limit (dB μ V/m)
42.710000	34.2	120.000	101.0	V	187.0	5.8	40.0
42.713000	34.2	120.000	101.0	V	187.0	5.8	40.0
42.798000	37.6	120.000	102.0	V	277.0	2.4	40.0
42.904000	34.7	120.000	185.0	V	90.0	5.3	40.0

43.183000	32.6	120.000	185.0	V	270.0	7.4	40.0
43.277000	29.2	120.000	285.0	V	183.0	10.8	40.0

Channel 39:

Frequency (MHz)	QuasiPeak (dB μ V/m)	Bandwidth (kHz)	Height (cm)	Polarization	Azimuth (deg)	Margin (dB)	Limit (dB μ V/m)
41.943000	34.6	120.000	116.0	V	138.0	5.4	40.0
42.628000	32.6	120.000	100.0	V	78.0	7.4	40.0
43.274000	34.7	120.000	100.0	V	270.0	5.3	40.0
43.289000	33.8	120.000	100.0	V	45.0	6.2	40.0
44.338000	32.4	120.000	100.0	V	289.0	7.6	40.0
46.278000	26.8	120.000	100.0	V	289.0	13.2	40.0

Channel 78:

Frequency (MHz)	QuasiPeak (dB μ V/m)	Bandwidth (kHz)	Height (cm)	Polarization	Azimuth (deg)	Margin (dB)	Limit (dB μ V/m)
42.710000	33.9	120.000	100.0	V	-8.0	6.1	40.0
42.713000	33.2	120.000	116.0	V	7.0	6.8	40.0
42.919000	29.7	120.000	202.0	V	7.0	10.3	40.0
43.368000	27.7	120.000	318.0	V	172.0	12.3	40.0
44.047000	30.6	120.000	185.0	V	187.0	9.4	40.0
44.638000	32.2	120.000	100.0	V	97.0	7.8	40.0

Notes:

1. Radiated emissions were measured with an instrument using Quasi-peak detector mode in frequency range from 30 MHz to 1000MHz, and with peak detector mode in frequency range from 1GHz - 26.5 GHz.
- 2 Total dBuV/m = Reading dBuV/m - Cable Loss dB + Antenna Gain dB.

Test Plots:

RE 30MHz-1GHz H

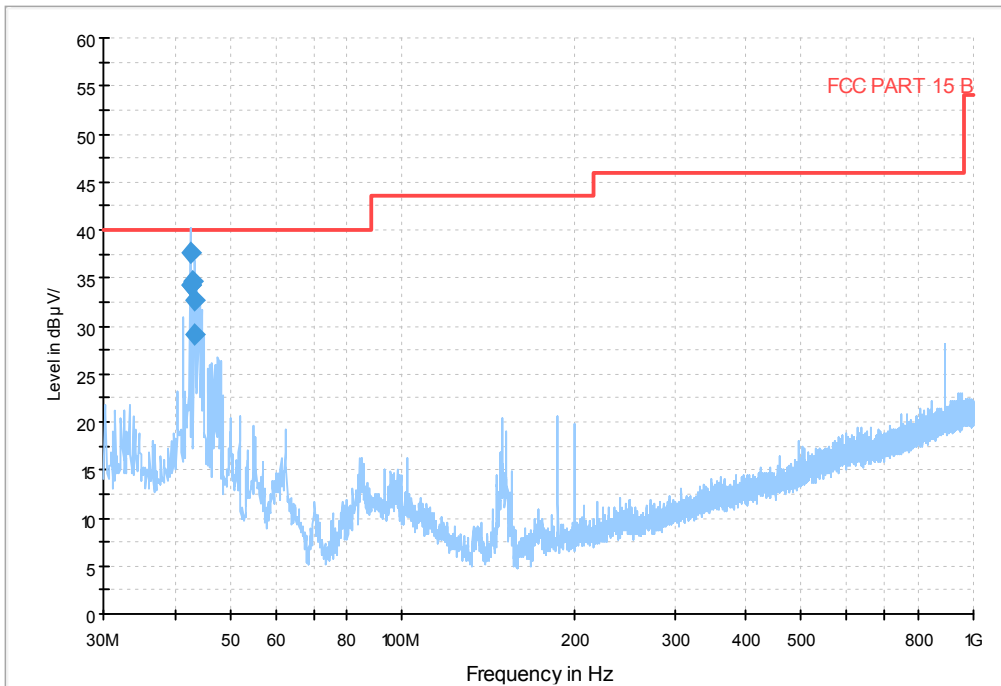

GFSK DH5 Channel 0 30MHz-1GHz

RE 1GHz-3GHz

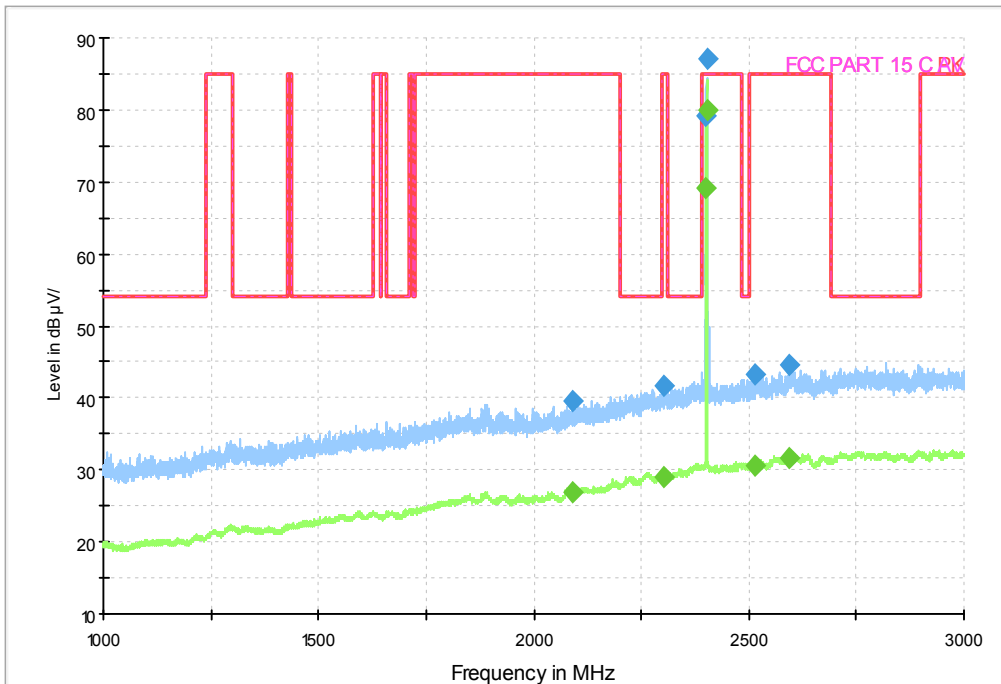

GFSK DH5 Channel 0 1-3GHz

RE 3GHz-18GHz

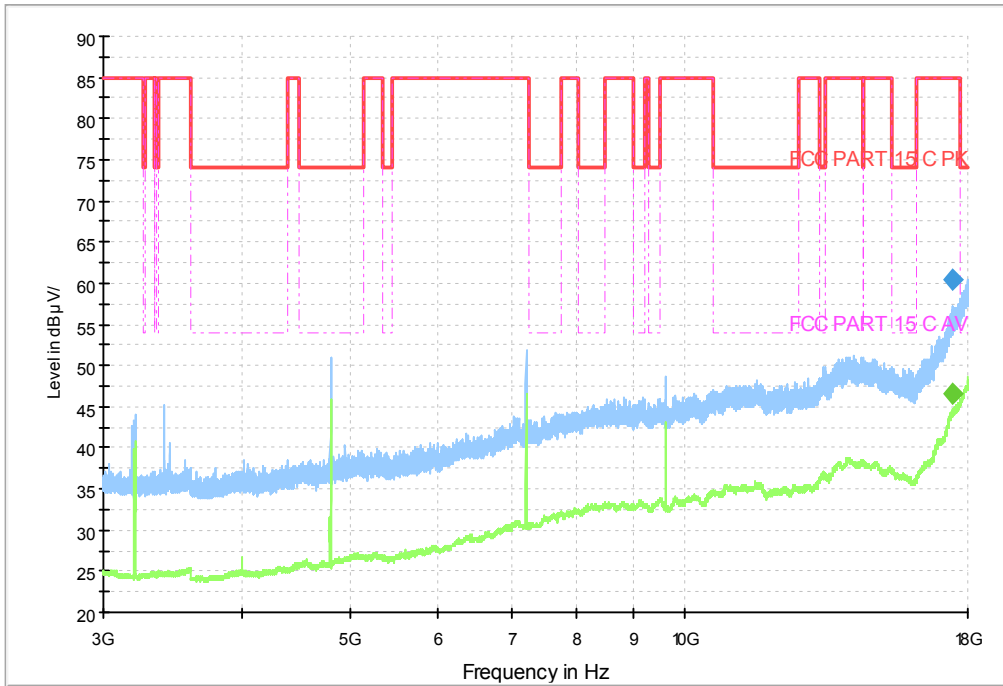

GFSK DH5 Channel 0 3G-18GHz

RE 30MHz-1GHz

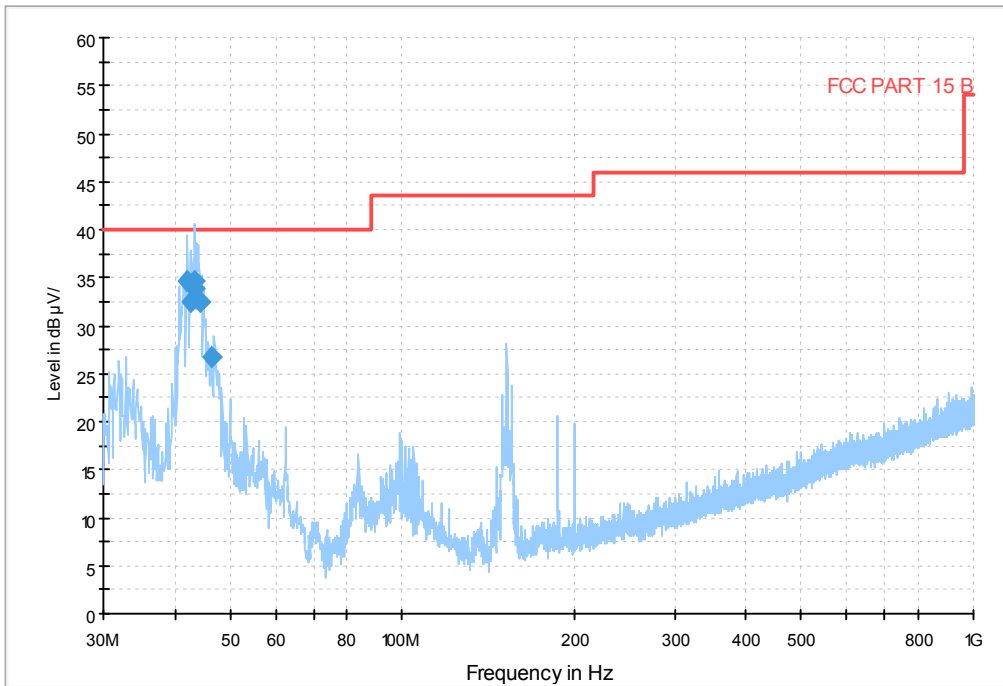

GFSK DH5 Channel 39 30MHz-1GHz

RE 1GHz-3GHz

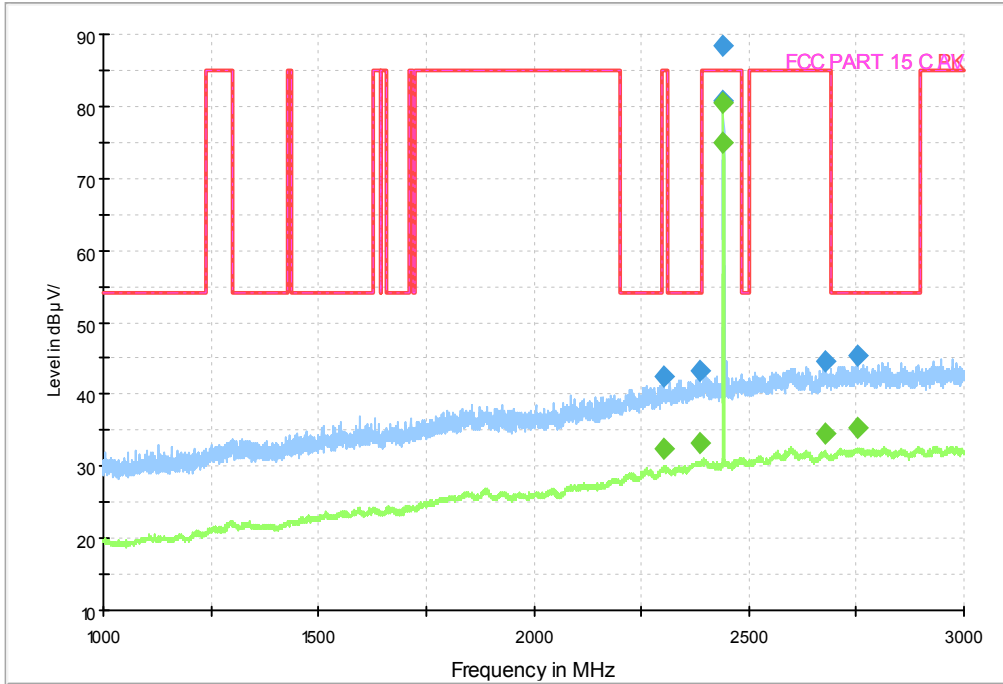

GFSK DH5 Channel 39 1-3GHz

RE 3GHz-18GHz

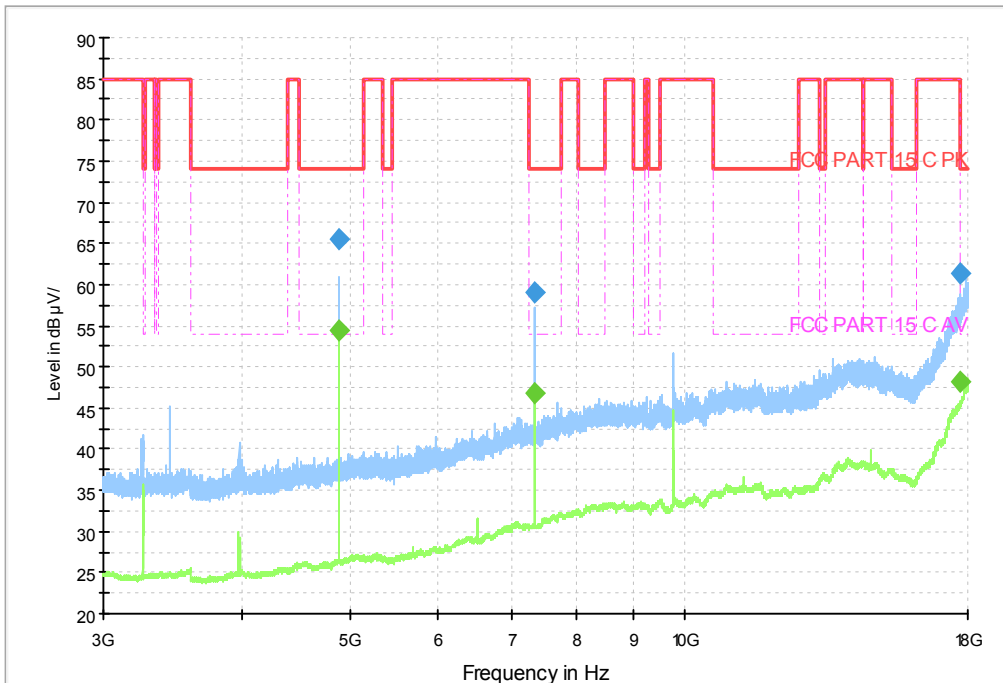

GFSK DH5 Channel 39 3-18GHz

RE 30MHz-1GHz H

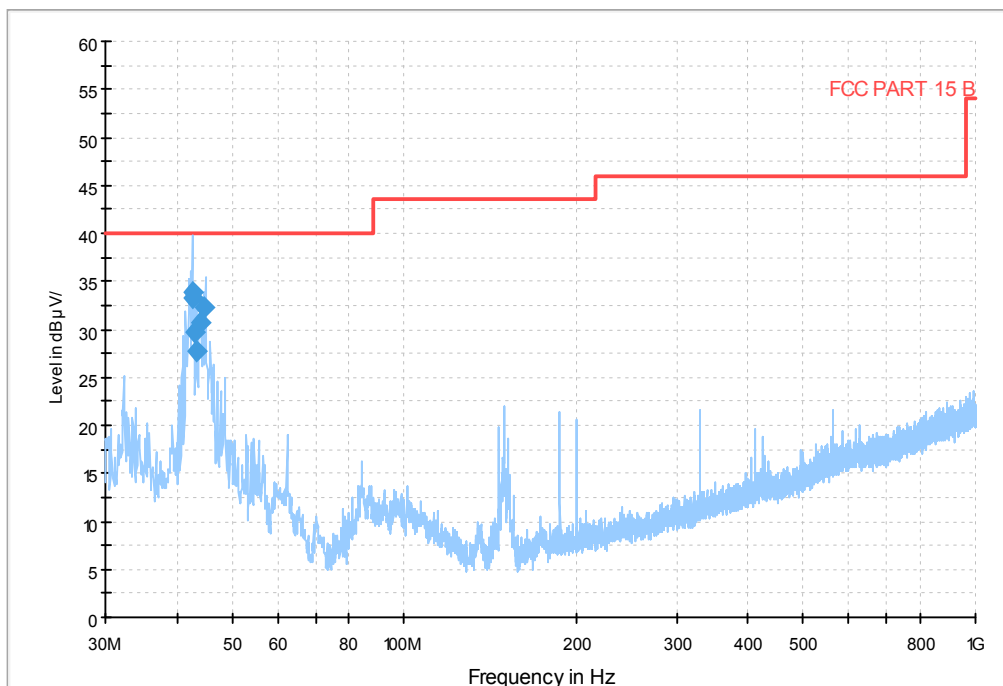

GFSK DH5 Channel 78 30MHz-1GHz

RE 1GHz-3GHz

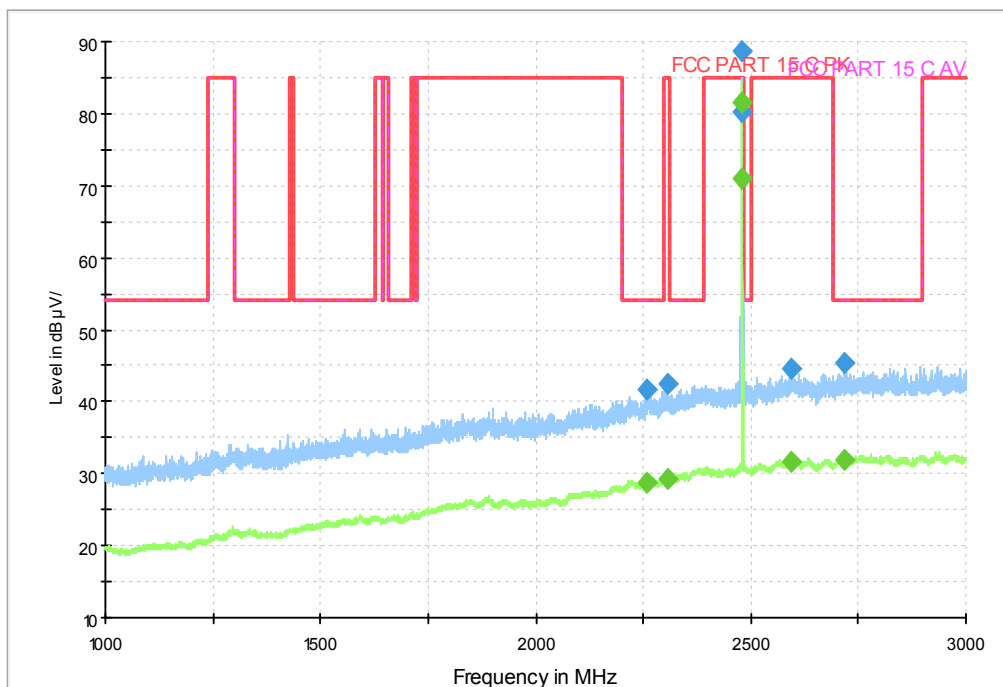

GFSK DH5 Channel 78 1-3GHz

RE 3GHz-18GHz

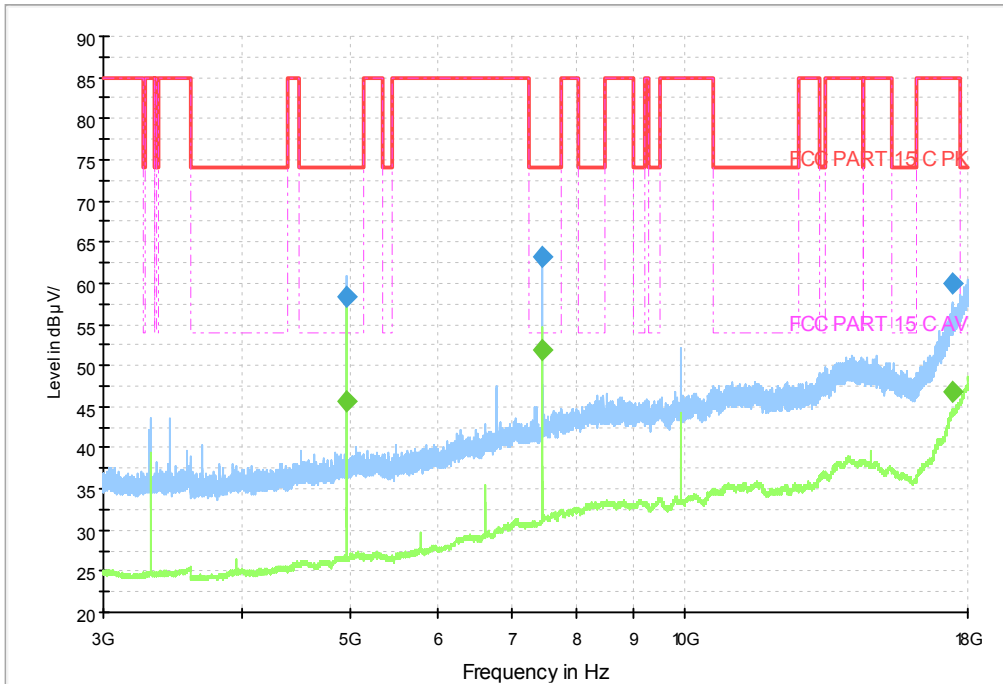

GFSK DH5 Channel 39 3-18GHz

Copy (2) of FCC Part 15C 18-26G

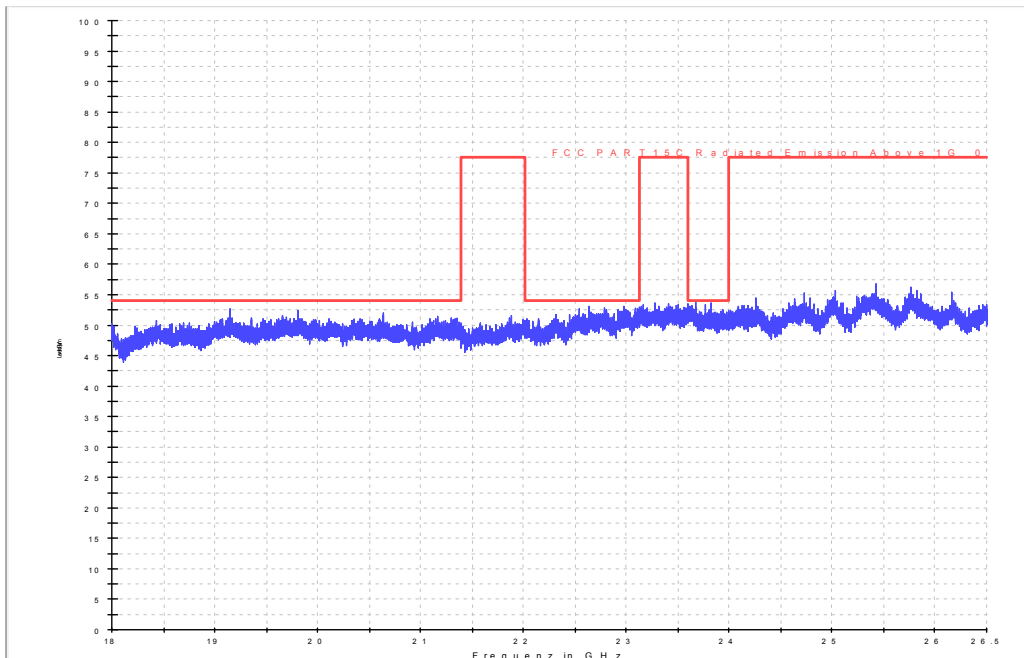

GFSK DH5 all channels

Test photo

See the Pic1- Pic6 in document "U100_Wifi_BT_Test Setup Photos".

4.8 Power line Conducted Emissions

Specifications:	ANSI C63.4 voltage mains test					
Date of Test	2015-06-15					
Test conditions:	Ambient Temperature:15°C-35°C Relative Humidity:30%-60% Air pressure: 86-106kPa					
Operation Mode	Hopping					
Test Results:	Pass					
Test equipment Used:						
Number	Description	Manufacturer	Model Number	Serial Number	Cal Due	State
1	EMI Test Receiver	R/S	ESCI	101214	2016-03-05	Normal
2	Artificial Mains Network	R/S	ENV216	101128	2016-03-05	Normal
3	Wireless Connectivity Test Set	R/S	CMW500	152395	2016-01-28	Normal

LIMIT

For an intentional radiator which is designed to be connected to the public utility (AC) power line, the radio frequency voltage that is conducted back onto the AC power line on any frequency or frequencies within the band 150 kHz to 30 MHz shall not exceed 250 microvolt (The limit decreases linearly with the logarithm of the frequency in the range 0.15 MHz to 0.50 MHz). The limits at specific frequency range are listed as follows:

Limits of the conducted disturbance at the AC mains ports:

Frequency range	Limit(Quasi-peak)	Limit(Average)
0.15 MHz to 0.5 MHz	66 dBµV – 56 dBµV	56 dBµV – 46 dBµV
>0.5 MHz to 5MHz	56 dBµV	46 dBµV
>5 MHz to 30 MHz	60 dBµV	50 dBµV

NOTE: The limit decreases linearly with the logarithm of the frequency in the range 0.15 MHz to 0.50 MHz.

Compliance with this provision shall be based on the measurement of the radio frequency voltage between each power line (LINE and NEUTRAL) and ground at the power terminals.

Test Setup

The EUT was placed in a shielding room. The BLUETOOTH TESTER was used to set the TX channel and power level. The ac adapter output is connected to Receiver through an AMN (Artificial Mains Network).

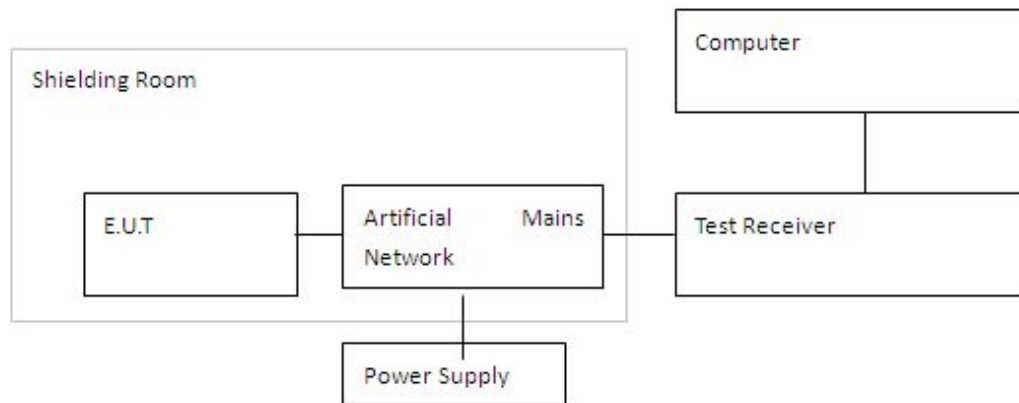

TEST PROCEDURE

1. The EUT is placed on a wooden table 80 cm above the reference ground plane.
2. The EUT is connected via LISN to a test power supply.
3. The measurement results are obtained as described below:
4. Detectors – Quasi Peak and Average Detector.

The measurement is made according to Public notice FCC Public Notice DA 00-705, March 2000, and ANSI C63.4-2014.

Test Result:

Line L&N					
Detector (QP)	Frequency (MHz)	Level (dBµV)	Limit (dBµV)	Line	PE
QP	0.150000	30.3	66.0	N	FLO
QP	0.172475	29.2	64.8	N	FLO
QP	0.449962	26.1	56.9	L	FLO
QP	0.488112	24.0	56.2	L	FLO
QP	2.175112	20.8	56.0	L	FLO
QP	2.199950	21.3	56.0	L	FLO

Line L&N					
Detector (AV)	Frequency (MHz)	Level (dBµV)	Limit (dBµV)	Line	PE
AV	0.164744	15.1	55.2	L	FLO
AV	0.182000	14.8	54.4	L	FLO
AV	0.443812	17.2	47.0	L	FLO
AV	0.444112	17.2	47.0	L	FLO
AV	2.295919	13.5	46.0	L	FLO
AV	2.355350	13.8	46.0	L	FLO

Copy of CISPR N&L1 Voltage 150k to 30MHz-Class B

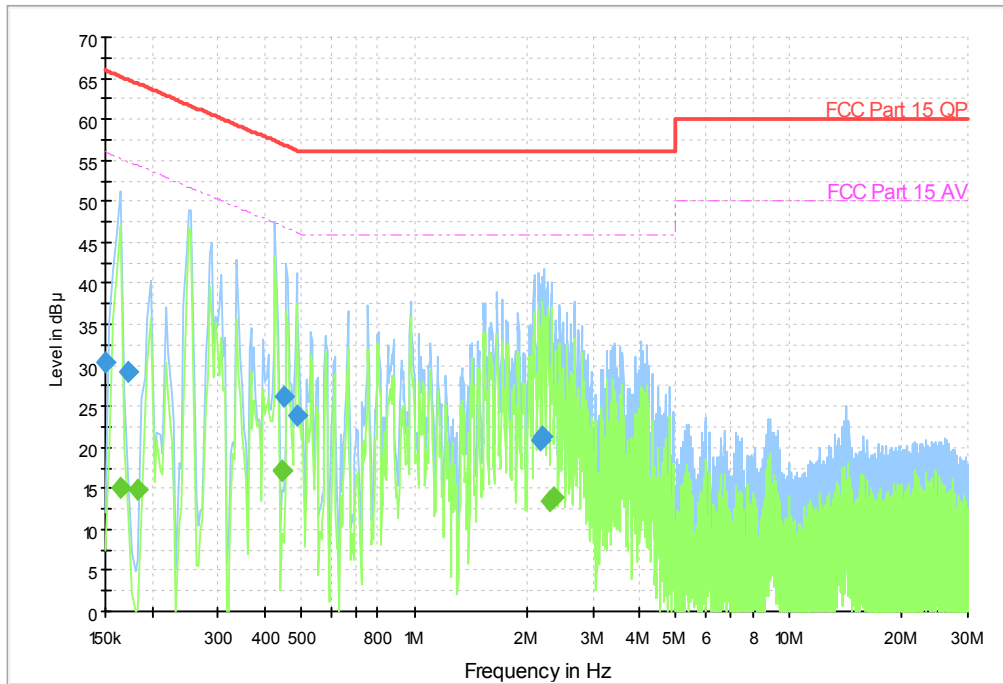

Line L & Line N

Test photo

See the Pic7 in document "U100_BT_Test Setup Photos".

Annex A External Photos

See the document "U100- External Photos".

Annex B Internal Photos

See the document "U100-Internal Photos".

ANNEX C Deviations from Prescribed Test Methods

No deviation from Prescribed Test Methods.

————— **The End of this Report** —————