



TEST REPORT

REPORT NUMBER: B16X50165-WWAN_Rev1

ON

Type of Equipment: Pad
Model Name: Ilium Pad T7X
Manufacturer: Amer Mobile Ltd.,com

ACCORDING TO

FCC CFR Part 2, FREQUENCY ALLOCATIONS AND RADIO TREATY MATTERS; GENERAL RULES AND REGULATIONS; e-CFR, Mar 17, 2015

PART 22, PUBLIC MOBILE SERVICES , e-CFR, Mar 17, 2015

PART 24, PERSONAL COMMUNICATIONS SERVICES, e-CFR, Mar 17, 2015

PART 27,MISCELLANEOUS WIRELESS COMMUNICATIONS SERVICES, e-CFR, Aug. 15, 2014

China Telecommunication Technology Labs.

Month date, year

Jun, 8, 2016

Signature



He Guili

Director

Note:

The test results in this test report relate only to the devices specified in this report. This report shall not be reproduced except in full without the written approval of China Telecommunication Technology Labs.

Report No.: B16X50165-WWAN_Rev1

FCC ID: ZC4T7X

Report Date: 2016-06-08

Test Firm Name: China Telecommunication Technology Labs

FCC Registration Number: 840587

Statement

The measurements shown in this report were made in accordance with the procedures described on test pages. All reported tests were carried out on a sample equipment to demonstrate limited compliance with FCC CFR 47 Parts 2, 22, 24, 27. The sample tested was found to comply with the requirements defined in the applied rules.

CONTENTS

1 GENERAL INFORMATION	4
1.1 NOTES	4
1.2 TESTERS	5
1.3 TESTING LABORATORY INFORMATION	6
1.4 DETAILS OF APPLICANT OR MANUFACTURER	7
2 TEST ITEM.....	8
2.1 GENERAL INFORMATION	8
2.2 OUTLINE OF EQUIPMENT UNDER TEST	8
2.3 MODIFICATIONS INCORPORATED IN EUT	8
2.4 EQUIPMENT CONFIGURATION.....	8
2.5 OTHER INFORMATION.....	8
3 SUMMARY OF TEST RESULTS.....	9
4 TEST EQUIPMENTS AND ANCILLARIES USED FOR TESTS.....	10
5 TEST RESULTS	11
5.1 CONDUCTED RF POWER OUTPUT.....	11
5.2 OCCUPIED BANDWIDTH.....	15
5.3 CONDUCTED SPURIOUS EMISSION	21
5.4 RADIATED SPURIOUS EMISSION	33
5.5 BAND EDGE.....	37
5.6 FREQUENCY STABILITY OVER TEMPERATURE VARIATION.....	42
5.7 FREQUENCY STABILITY OVER VOLTAGE VARIATION	44
5.8 PEAK TO AVERAGE RATIO.....	46
5.9 ERP AND EIRP.....	48
ANNEX A EUT PHOTOS	53
ANNEX B DEVIATIONS FROM PRESCRIBED TEST METHODS	54

1 General Information

1.1 Notes

All reported tests were carried out on a sample equipment to demonstrate limited compliance with FCC CFR 47 Parts 2, 22, 24, 27.

The test results of this test report relate exclusively to the item(s) tested as specified in section 2.

The following deviation from, additions to, or exclusions from the test specifications have been made. See Annex B.

China Telecommunication Technology Labs authorizes the applicant or manufacturer (see section 1.4) to reproduce this report provided, and the test report may only be reproduced or published in full. Reproduction or publication of extracts from the report requires the prior written approval of China Telecommunication Technology Labs. Mr. He Guili.

Any use which a third party makes of this report, or any reliance on or decisions to be made based on it, are the responsibility of such third parties. Chongqing Institute of Telecommunications accepts no responsibility for damages, if any, suffered by any third party as a result of decisions made or actions based on this report.

1.2 Testers

Name: Li Guoqing
Position: Engineer
Department: Department of RF test
Date: 2016-05-03 to 2016-06-08
Signature: 李国庆

Editor of this test report:

Name: Li Guoqing
Position: Engineer
Department: Department of RF test
Date: 2016-06-08
Signature: 李国庆

Technical responsibility for area of testing:

Name: Zou Dongyi
Position: Manager
Department: Director of the laboratory
Date: 2016-06-08
Signature: 邹东屹

1.3 Testing Laboratory information

1.3.1 Location

Name: China Telecommunication Technology Labs.
Address: No. 11, Yue Tan Nan Jie, Xi Cheng District
BEIJING
P. R. CHINA, 100083
Tel: +86 10 68094053
Fax: +86 10 68011404
Email: emc@chinattl.com

1.3.2 Details of accreditation status

Accredited by: China National Accreditation Service for Conformity
Assessment (CNAS)
Registration number: CNAS Registration No. CNAS L0570
Standard: ISO/IEC 17025:2005

1.3.3 Test location, where different from section 1.3.1

Name: -----
Street: -----
City: -----
Country: -----
Telephone: -----
Fax: -----
Postcode: -----

1.4 Details of applicant or manufacturer

1.4.1 Applicant

Name: Corporativo Lanix S.A.de C.V.
Address: Carretera Internacional Hermosillo - Nogales Km 8.5
Hermosillo, Sonora, México
Country: México
Telephone: 0052 16621090811
Fax: --
Contact: Oscar Guzman
Email: oguzman@lanix.com

1.4.2 Manufacturer (if different from applicant in section 1.4.1)

Name: Amer Mobile Ltd.,com
Address: 17/F, Tower B, Huihai Sqr, Chuangye Rd, Longhua Dist,
Shenzhen, China
Country: China
Telephone: 86 13421844861
Fax: --
Contact: Windy.Chen
Email: chengang841230@163.com

2 Test Item

2.1 General Information

Manufacturer: Amer Mobile Ltd.,com

Type of Equipment: Pad

Model Name: Ilium Pad T7X

S3/10: 358066070000178

Serial Number: S5/10: 358066070000160

S8/10: 358066070000665

Production Status: Product

Receipt date of test item: 2016-05-03

2.2 Outline of Equipment under Test

The Ilium Pad T7X, referred to as “EUT” hereafter, is a multi-band wireless modem operating on the GSM/UMTS networks. The table below shows the supported bands for the EUT.

Technology	Band	UL Freq.(MHz)	DL Freq.(MHz)	Note
GSM	GSM850	824 - 849	869 - 894	--
	PCS1900	1850 - 1910	1930 - 1990	--
WCDMA	B2	1850 - 1910	1930 - 1990	--
	B5	824 - 849	869 - 894	--

2.3 Modifications Incorporated in EUT

The EUT has not been modified from what is described by the brand name and unique type identification stated above.

2.4 Equipment Configuration

Equipment configuration list:

Item	Generic Description	Manufacturer	Type	Serial No.	Remarks
A	Modem	Amer Mobile Ltd.,com	Ilium Pad T7X	S3/10: 358066070000178 S5/10: 358066070000160 S8/10: 358066070000665	None
B	Adaptor	None	None	--	None

2.5 Other Information

--

3 Summary of Test Results

A brief summary of the tests carried out is shown as following.

FCC Rules	Name of Test	Result
2.1046, 22.913(a), 24.232(c), 27.50	Conducted RF Power Output	Pass
2.1049, 22.917(b), 24.238(b)	Occupied Bandwidth	*Note 1
2.1051, 2.1053, 24.238, 22.917	Conducted spurious emissions	Pass
2.1051, 2.1053, 24.238, 22.917, 27.53	Radiated Spurious Emission	Pass
2.1051, 2.1053, 24.238, 22.917, 27.53	Band Edge	Pass
2.1055, 22.355, 24.235, 27.54	Frequency Stability over Temperature Variation	Pass
2.1055, 22.355, 24.235, 27.54	Frequency Stability over Voltage Variation	Pass
24.232, 27.50	Peak to Average Ratio	Pass
22.913(a), 24.232(b)	ERP and EIRP	Pass

4 Test Equipments and Ancillaries Used For Tests

The test equipments and ancillaries used are as follows.

No.	Equipment	Model	SN	Manufacture	Cal. Due Date
1	EMI Test Receiver	ESU26	100367	R&S	2017-03-04
2	Trilog super broadband test antenna	VULB 9163	9163-544	R&S	2017-01-05
3	Double-Ridged Horn Antenna	HF907	100356	R&S	2016-12-12
4	Fully-Anechoic Chamber	11.8m×6.5m×6.3m	--	ETS	2017-08-19
5	Universal Radio Communication Tester	CMW500	128181	R&S	2017-03-04
6	Signal Generator	SMU200A	104517	R&S	2017-03-04
7	spectrum analyzer	FSQ 26	201137/026	R&S	2017-03-04
8	spectrum analyzer	N9020A	MY50200376	Agilent	2017-03-04
9	Universal Radio Communication Tester	CMU200	112012	R&S	2017-03-04
10	Climate chamber	SH-241	92010759	ESPEC	2017-03-04
11	DC Power Supply	N6705B	MY50000919	Agilent	2017-12-06

5 Test Results

5.1 Conducted RF Power Output

Specifications:	FCC Part 2.1046, 22.913(a), 24.232(c), 27.50
DUT Serial Number:	S3/10: 358066070000178
Test conditions:	Ambient Temperature:15°C-35°C Relative Humidity:30%-60% Air pressure: 86-106kPa
Test Results:	Pass

Limit Level Construction:

According to Part 22.913(a), the ERP of mobile transmitters and auxiliary test transmitters must not exceed 7 Watts.

According to Part 24.232(c), mobile and portable stations are limited to 2 watts EIRP and the equipment must employ a means for limiting power to the minimum necessary for successful communications.

According to Part 27.50(b), portable stations (hand-held devices) transmitting in the 746-757 MHz, 776-788 MHz, and 805-806 MHz bands are limited to 3 watts ERP.

According to Part 27.50(c), portable stations (hand-held devices) in the 600 MHz uplink band and the 698-746 MHz band, and fixed and mobile stations in the 600 MHz uplink band are limited to 3 watts ERP;

According to Part 27.50(d), fixed, mobile, and portable (hand-held) stations operating in the 1710-1755 MHz band and mobile and portable stations operating in the 1695-1710 MHz and 1755-1780 MHz bands are limited to 1 watt EIRP.

Test Setup:

During the test, the EUT was controlled via the Wireless Telecommunications Test Set to ensure max power transmission and proper modulation and measured by spectrum analyzer.

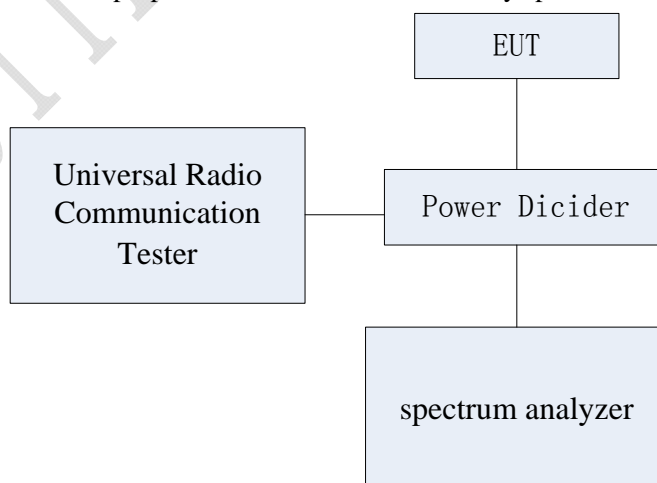

Test Method:

- 1) The EUT was coupled to the spectrum analyzer and the Wireless Telecommunications Test Set through a power divider. The loss of the cables the test system is calibrated to correct the readings.
 - 2) The spectrum analyzer was set to Maxpeak Detector function and Maximum hold mode.
 - 3) The resolution bandwidth of the spectrum analyzer was comparable to the emission bandwidth.
- Note: --

5.1.1 GSM850 Conducted RF Power Output Results

GPRS GMSK Mode:

Channel No.	Maximum output power(pk) [dBm]			
	1TS	2TS	3TS	4TS
128 (824.2MHz)	32.70	31.65	29.43	28.35
190 (836.6MHz)	32.56	31.50	29.28	28.20
251 (848.8MHz)	32.45	31.38	29.18	28.08

EGPRS GMSK Mode:

Channel No.	Maximum output power(pk) [dBm]			
	1TS	2TS	3TS	4TS
128 (824.2MHz)	32.77	31.71	29.44	28.39
190 (836.6MHz)	32.65	31.56	29.32	28.24
251 (848.8MHz)	32.56	31.43	29.21	28.11

5.1.2 PCS1900 Conducted RF Power Output Results

GPRS GMSK Mode:

Channel No.	Maximum output power(pk) [dBm]			
	1TS	2TS	3TS	4TS
512 (1850.2MHz)	29.87	29.03	26.69	25.50
661 (1880.0MHz)	30.07	29.06	26.72	25.53
810 (1909.8MHz)	30.09	28.94	26.58	25.40

EGPRS GMSK Mode

Channel No.	Maximum output power(pk) [dBm]			
	1TS	2TS	3TS	4TS
512 (1850.2MHz)	29.83	28.94	26.69	25.52
661 (1880.0MHz)	30.02	29.05	26.70	25.54
810 (1909.8MHz)	30.04	28.98	26.56	25.43

5.1.3 WCDMA Band2 Conducted RF Power Output Results

		Maximum output power(RMS) [dBm]		
Mode	3GPP Subtest	9262	9400	9538
RMC	--	23.06	23.14	23.06
HSDPA	1	22.06	22.15	22.10
	2	22.04	22.17	22.05
	3	21.59	21.60	21.57
	4	21.58	21.58	21.54
HSUPA	1	22.06	22.07	22.15
	2	22.04	22.17	22.05
	3	21.59	21.60	21.57
	4	21.58	21.58	21.54
	5	21.56	21.56	21.53

5.1.4 WCDMA Band5 Conducted RF Power Output Results

		Maximum output power(RMS) [dBm]		
Mode	3GPP Subtest	4132	4182	4233
RMC	--	22.64	22.67	22.81
HSDPA	1	21.65	21.58	21.71
	2	21.61	21.60	21.75
	3	21.08	21.14	21.28
	4	21.06	21.11	21.26
HSUPA	1	21.65	21.58	21.71
	2	21.61	21.60	21.75
	3	21.08	21.14	21.28
	4	21.06	21.11	21.26
	5	21.03	21.08	21.23

5.2 Occupied bandwidth

Specifications:	FCC Part 2.1049, 22.917(b), 24.238(b)
DUT Serial Number:	S3/10: 358066070000178
Test conditions:	Ambient Temperature:15°C-35°C Relative Humidity:30%-60% Air pressure: 86-106kPa
Test Results:	--

Test Setup

During the test, the EUT was controlled via the Wireless Communications Test Set to ensure max power transmission and proper modulation and measured by spectrum analyzer.

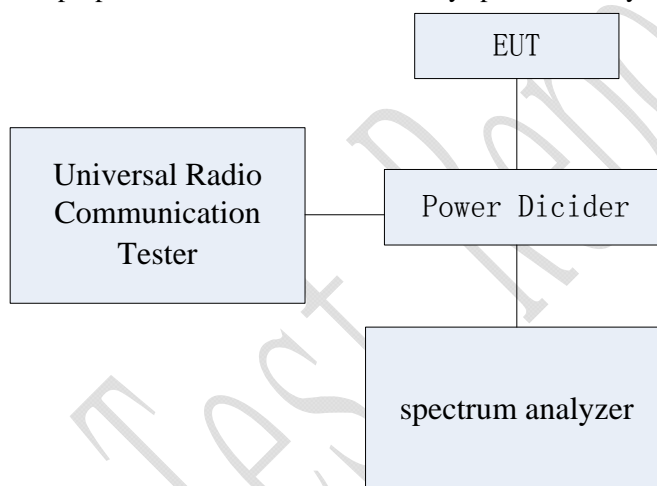

Test Method

The 99% occupied bandwidth was calculated from the spectrum analyzer. Markers in the spectrum analyzer were then placed between the calculated frequencies to show the calculated 99% power band. The -26dB bandwidth was also measured and recorded.

Note: --

5.2.1 GSM Mode Occupied Bandwidth Results

Band	EUT channel No.	Mode	99% OBW (MHz)	-26dBc OBW (MHz)
GSM850	128	GMSK	0.245	0.321
	190	GMSK	0.243	0.319
	251	GMSK	0.247	0.322
PCS1900	512	GMSK	0.247	0.324
	661	GMSK	0.245	0.317
	810	GMSK	0.248	0.324

5.2.2 WCDMA Band Mode Occupied Bandwidth Results

Band	EUT channel No.	Mode	99% OBW (MHz)	-26dBc OBW (MHz)
Band 2	9400	QPSK	4.150	4.695
Band 5	4182	QPSK	4.160	4.691

Graphical results for GSM :

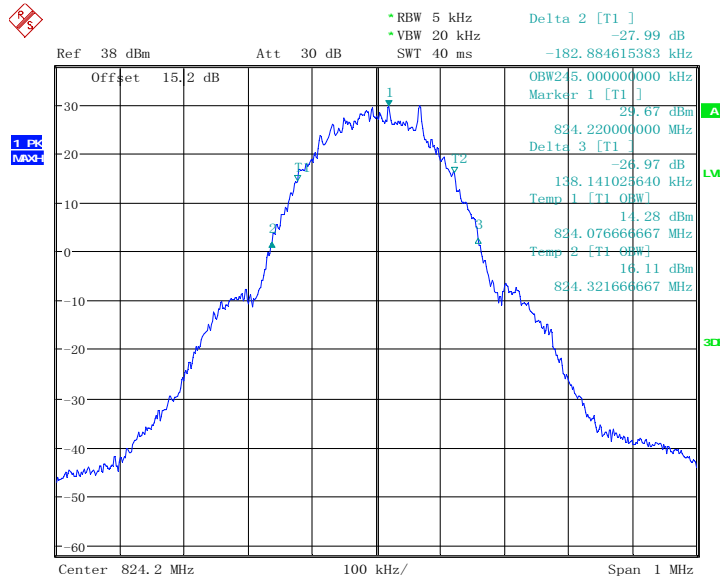

Date: 4. MAY. 2016 16:57:20

GMSK Channel 128

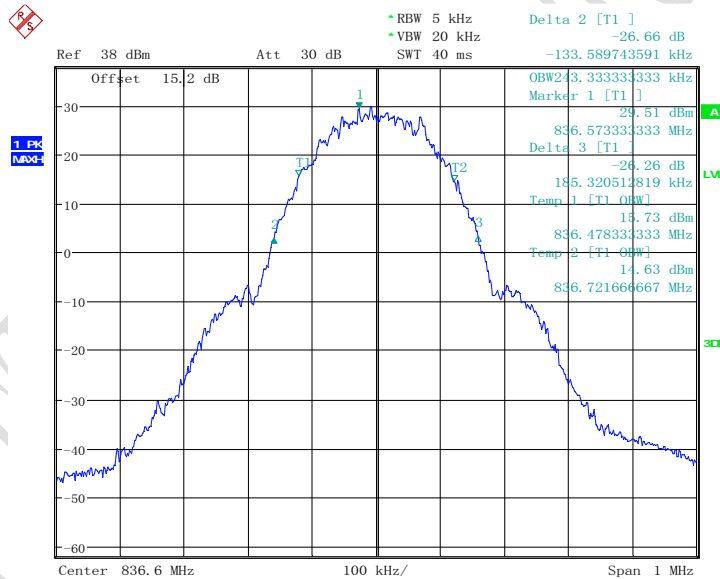

Date: 4. MAY. 2016 17:01:15

GMSK Channel 190

Report No.: B16X50165-WWAN_Rev1

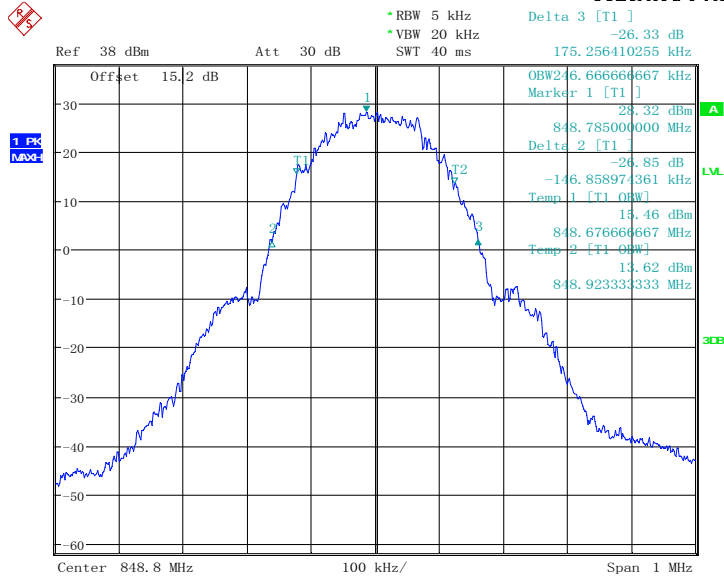

Date: 4.MAY.2016 17:02:39

GSM Channel 251

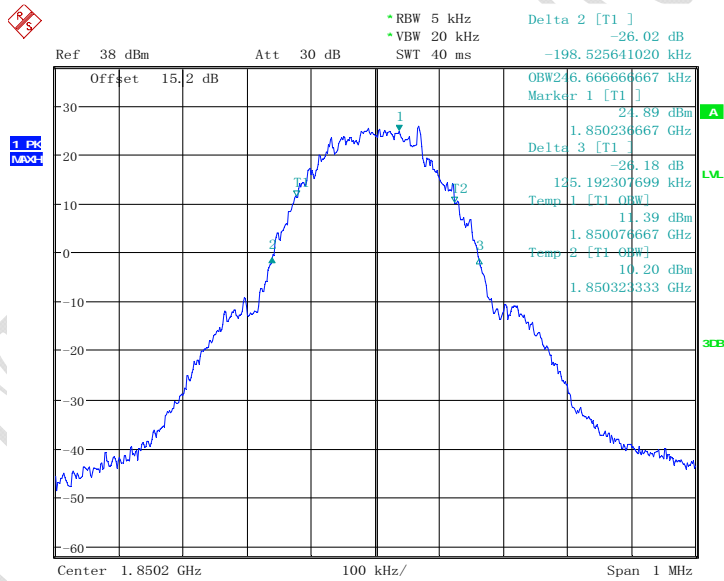

Date: 4.MAY.2016 17:16:12

GSM Channel 512

Report No.: B16X50165-WWAN_Rev1

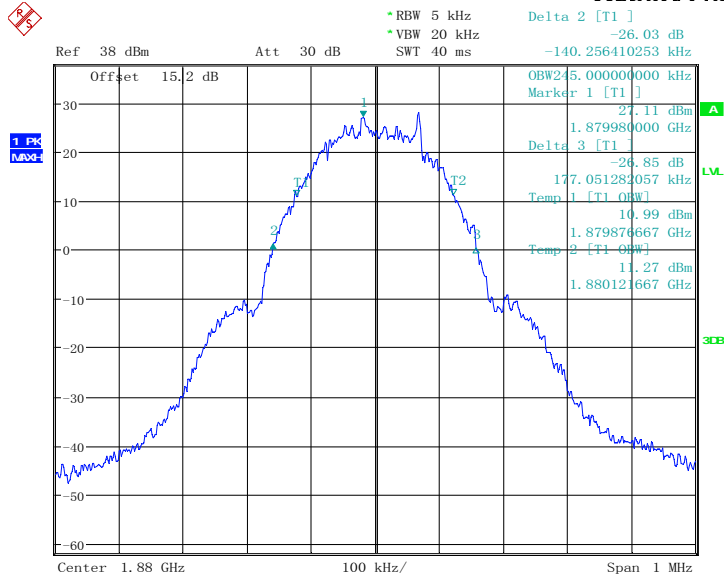

Date: 4. MAY. 2016 17:17:35

GSM Channel 661

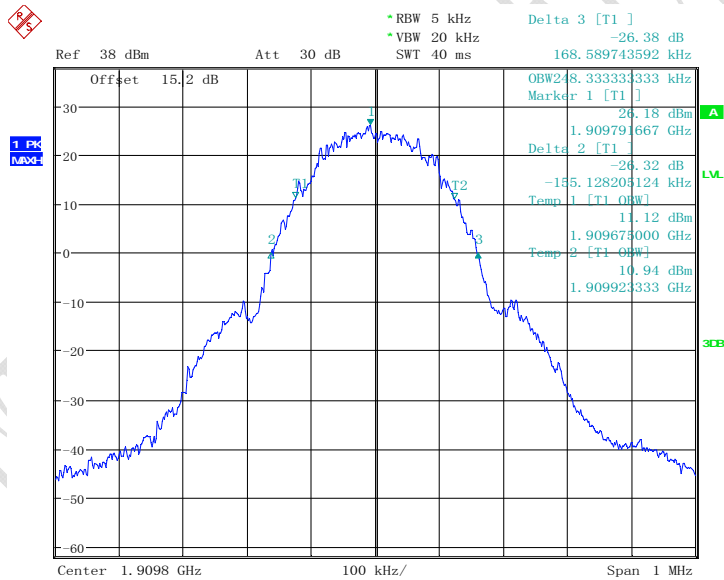

Date: 4. MAY. 2016 17:18:36

GSM Channel 810

Graphical results for WCDMA :

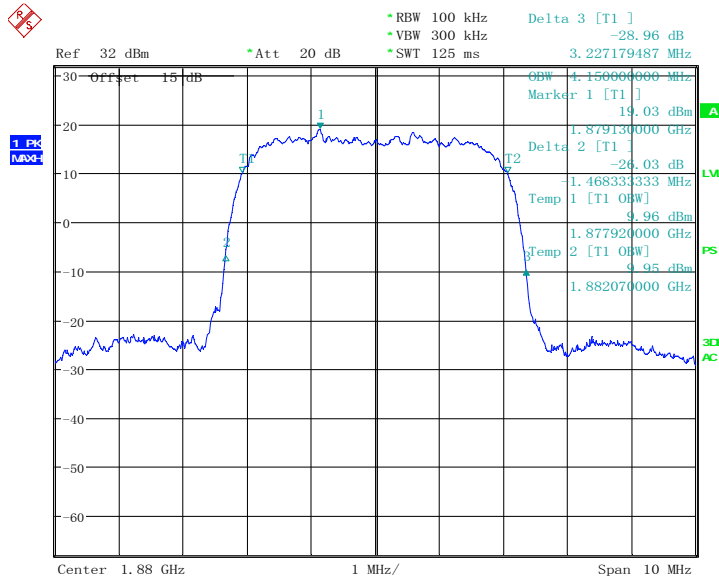

Date: 5. MAY. 2016 17:20:02

WCDMA B2 Channel 9400, QPSK

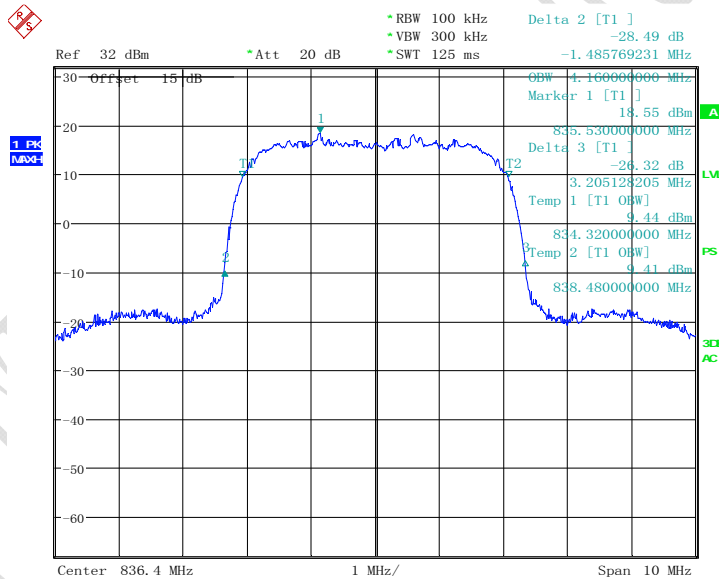

Date: 5. MAY. 2016 17:21:25

WCDMA B5 Channel 4182, QPSK

5.3 Conducted Spurious Emission

Specifications:	FCC Part 2.1051, 24.238, 2.1053, 22.917, 27.53
DUT Serial Number:	S3/10: 358066070000178
Test conditions:	Ambient Temperature:15°C-35°C Relative Humidity:30%-60% Air pressure: 86-106kPa
Test Results:	--

Limit Level Construction:

According to Part 22.917 (a), i.e., Out of band emissions. The power of any emission outside of the authorized operating frequency ranges must be attenuated below the transmitting power (P) by a factor of at least $43 + 10 \log(P)$ dB.

According to Part 24.238 (a), i.e., Out of band emissions. The power of any emission outside of the authorized operating frequency ranges must be attenuated below the transmitting power (P) by a factor of at least $43 + 10 \log(P)$ dB, so the limit level is:

$$P(\text{dBm}) - (43 + 10 \log(P)) \text{ dB} = -13\text{dBm}.$$

According to Part 27.53(h):

Except as otherwise specified below, for operations in the 1695-1710 MHz, 1710-1755 MHz, 1755-1780 MHz, 1915-1920 MHz, 1995-2000 MHz, 2000-2020 MHz, 2110-2155 MHz, 2155-2180 MHz, and 2180-2200 bands, the power of any emission outside a licensee's frequency block shall be attenuated below the transmitter power (P) in watts by at least $43 + 10 \log_{10}(P)$ dB

Limits for Radiated spurious emissions(UE)	
Frequency range	Limit Level /Resolution Bandwidth
30 MHz to 20000 MHz	-13dBm/1MHz

Test Setup:

During the test, the EUT was controlled via the Wireless Communications Test Set to ensure max power transmission and proper modulation and measured by spectrum analyzer.

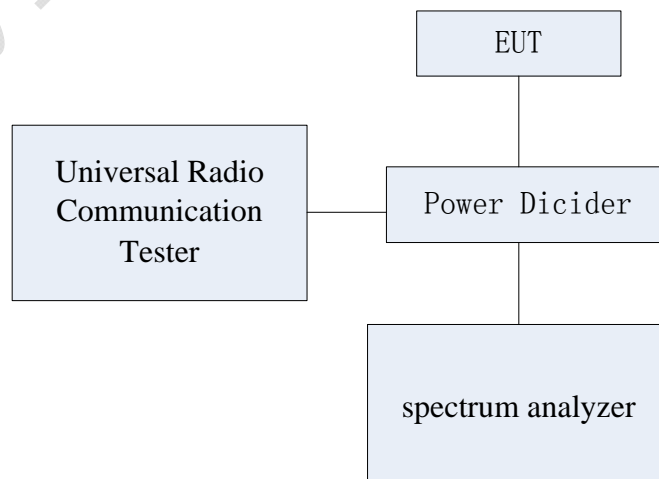

Test Method:

The measurement was performed accordance with section 2.2.13 of ANSI/TIA-603-B-2002: Land Mobile FM or PM Communications Equipment Measurement and Performance Standards.

The following steps outline the procedure used to measure the conducted emissions from the EUT.

1. Determine frequency range for measurements: From CFR 2.1057 the spectrum should be investigated from the lowest radio frequency generated in the equipment up to at least the 10th harmonic of the carrier frequency.

Note: --

5.3.1 GSM Band Mode Conducted Spurious Emission Results

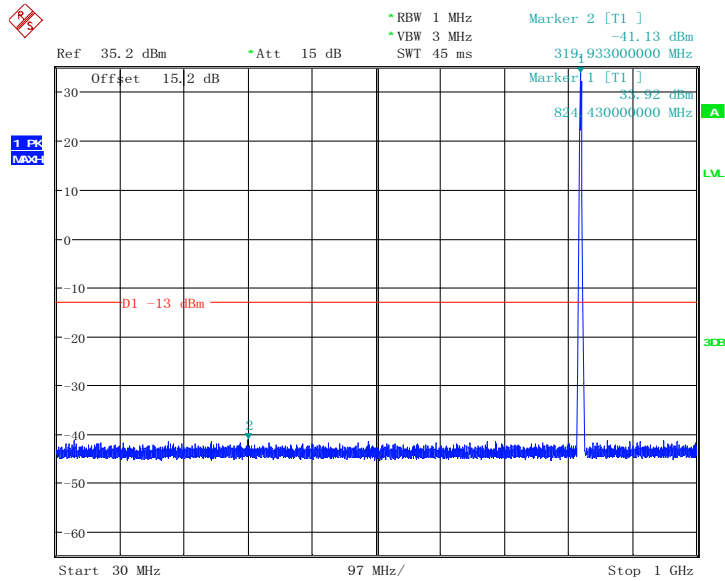

Date: 4. MAY. 2016 17:54:01

GMSK, Low channel, 824.200 MHz, 30MHz to 1GHz

Note: The strong emission shown in each case is the carrier signal.

Report No.: B16X50165-WWAN_Rev1

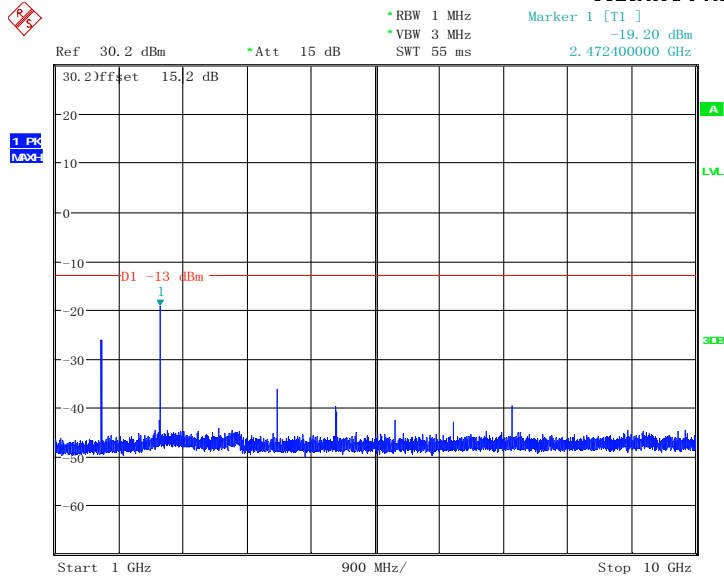

Date: 4. MAY. 2016 18:00:18

GMSK, Low channel, 824.200 MHz, 1GHz to 10GHz

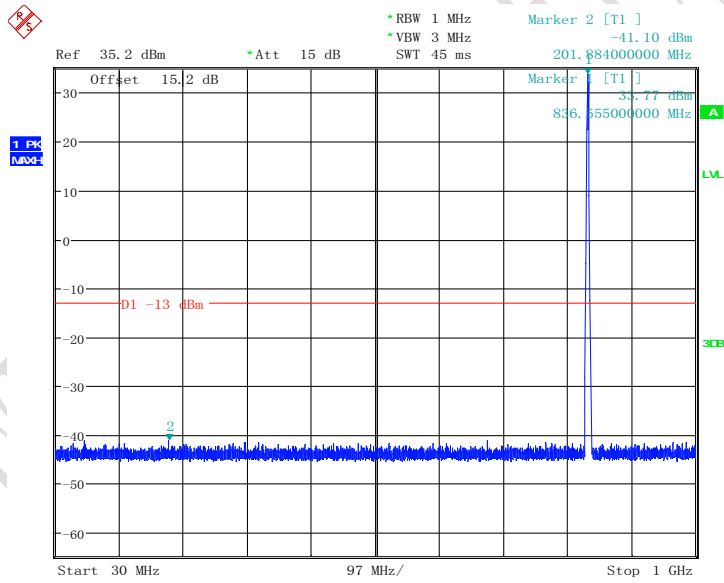

Date: 4. MAY. 2016 18:02:14

GMSK, Mid Channel, 836.6 MHz, 30MHz to 1GHz

Note: The strong emission shown in each case is the carrier signal.

Report No.: B16X50165-WWAN_Rev1

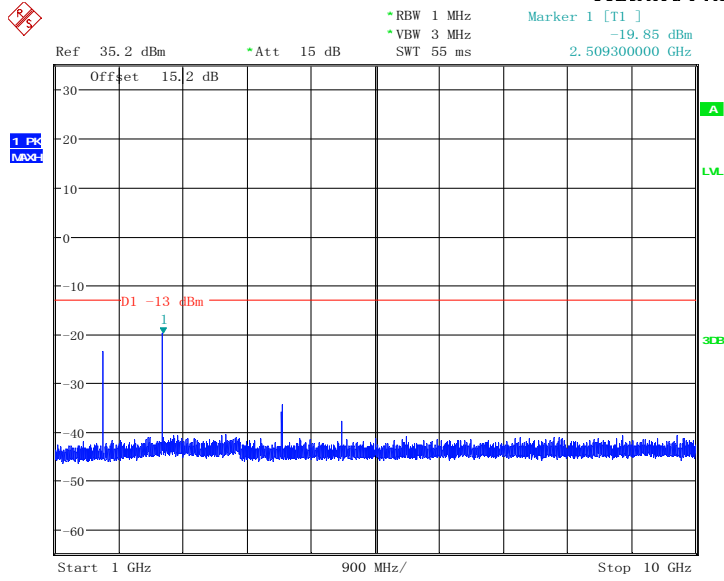

Date: 4. MAY. 2016 18:02:30

GMSK, Mid Channel, 836.6 MHz, 1GHz to 10GHz

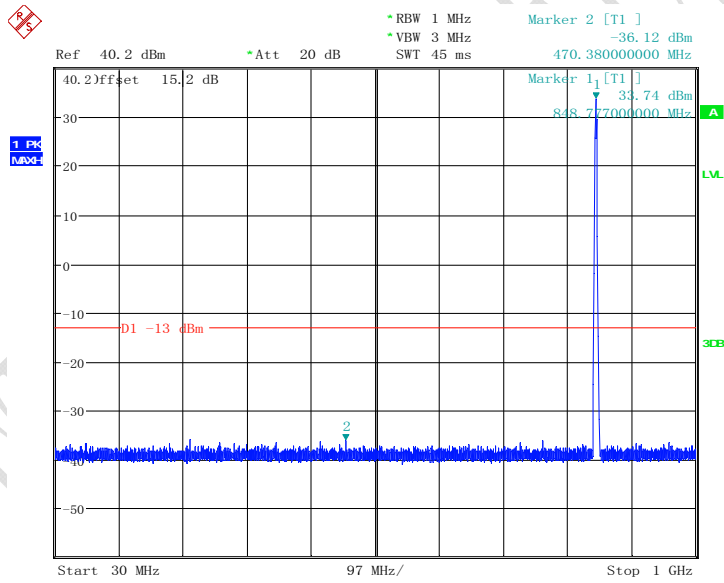

Date: 4. MAY. 2016 18:03:33

GMSK, High Channel, 848.8 MHz, 30MHz to 1GHz

Note: The strong emission shown in each case is the carrier signal.

Report No.: B16X50165-WWAN_Rev1

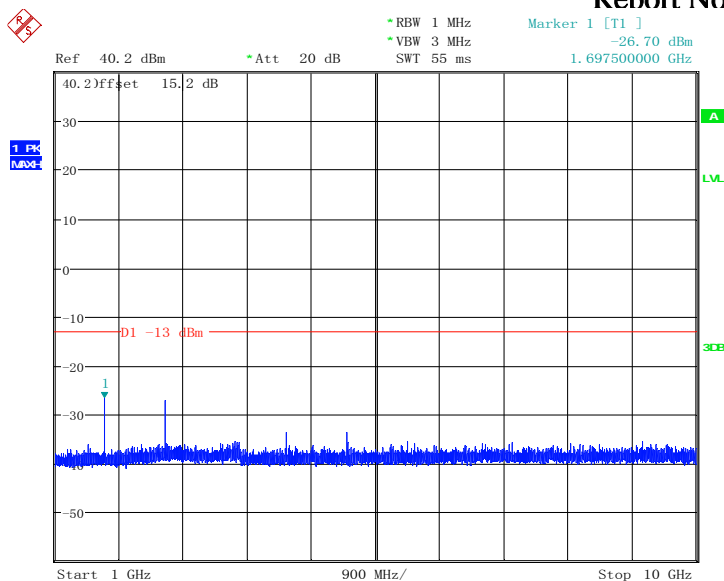

Date: 4. MAY. 2016 18:03:52

GMSK, High Channel, 848.8 MHz, 1GHz to 10GHz

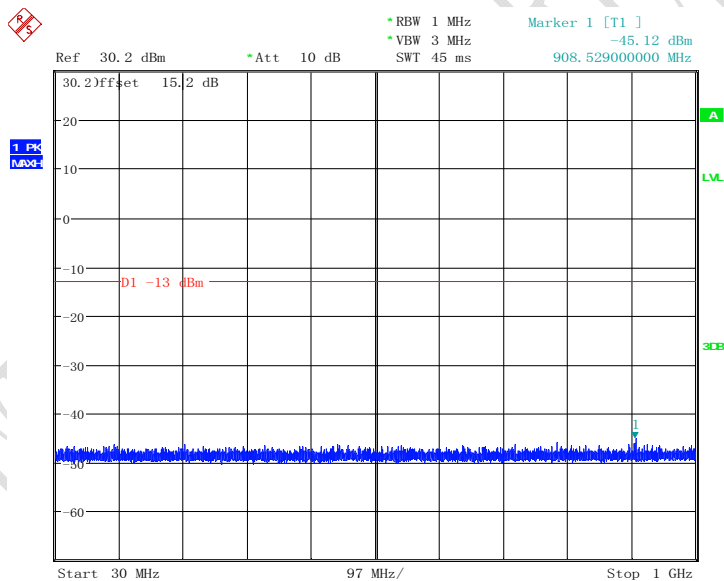

Date: 4. MAY. 2016 17:40:16

GMSK, Low channel, 1850.2 MHz, 30MHz to 1GHz

Report No.: B16X50165-WWAN_Rev1

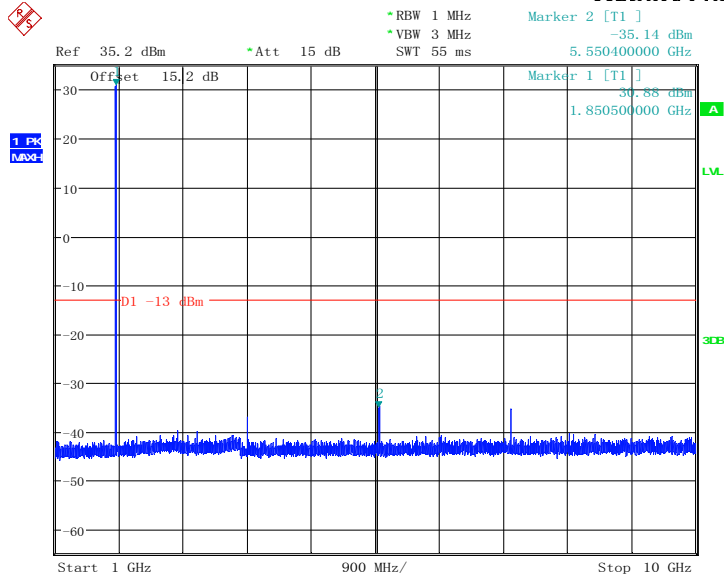

Date: 4. MAY. 2016 17:41:31

GMSK, Low channel, 1850.2 MHz, 1GHz to 10GHz

Note: The strong emission shown is the carrier signal.

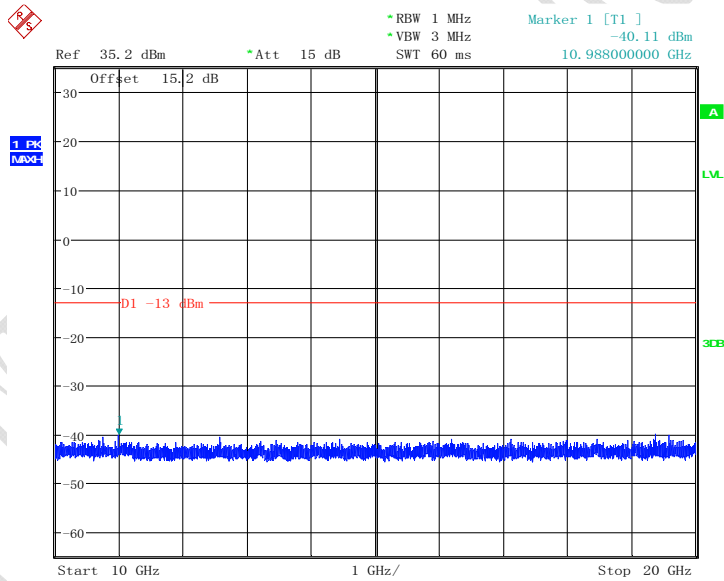

Date: 4. MAY. 2016 17:41:52

GMSK, Low channel, 1850.2 MHz, 10GHz to 20GHz

Report No.: B16X50165-WWAN_Rev1

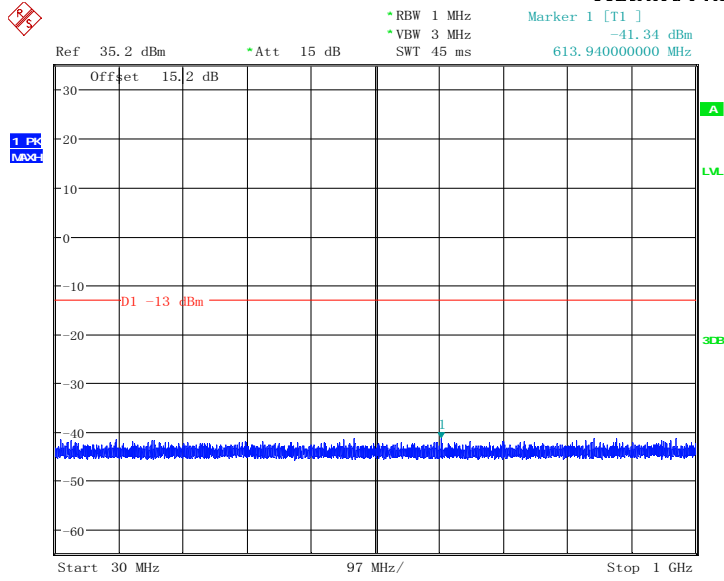

Date: 4. MAY. 2016 17:42:32

GMSK, Middle channel, 1880.0 MHz, 30MHz to 1GHz

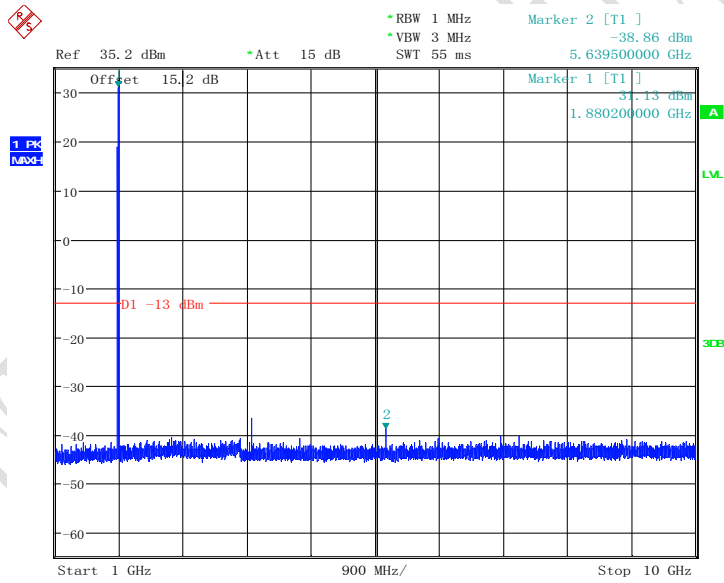

Date: 4. MAY. 2016 17:42:53

GMSK, Middle channel, 1880.0 MHz, 1GHz to 10GHz

Note: The strong emission shown is the carrier signal.

Report No.: B16X50165-WWAN_Rev1

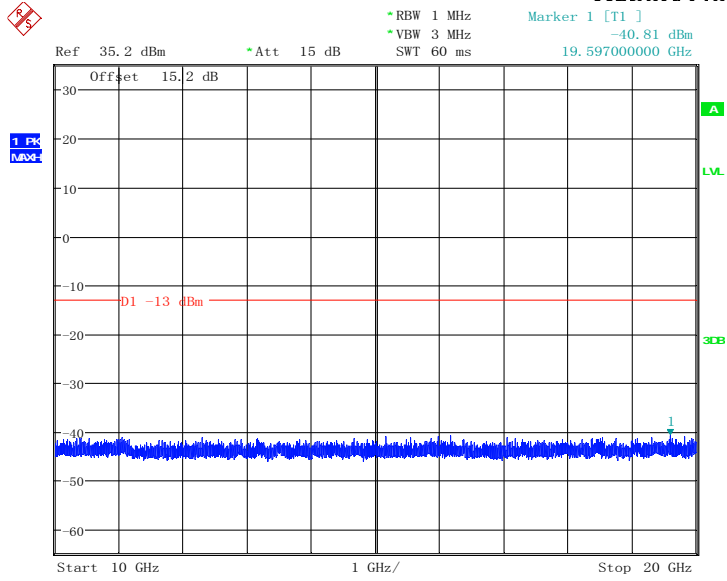

Date: 4. MAY. 2016 17:43:10

GMSK, Middle channel, 1880.0 MHz, 10GHz to 20GHz

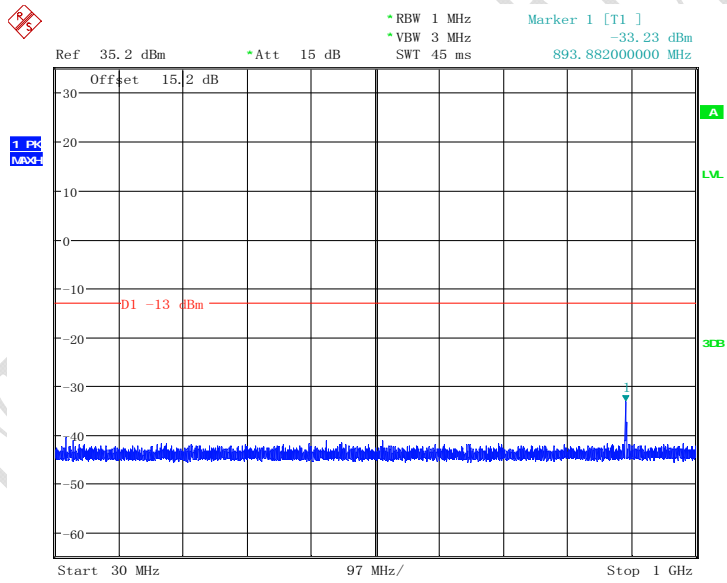

Date: 4. MAY. 2016 17:44:16

GMSK, High channel, 1909.8 MHz, 30MHz to 1GHz

Report No.: B16X50165-WWAN_Rev1

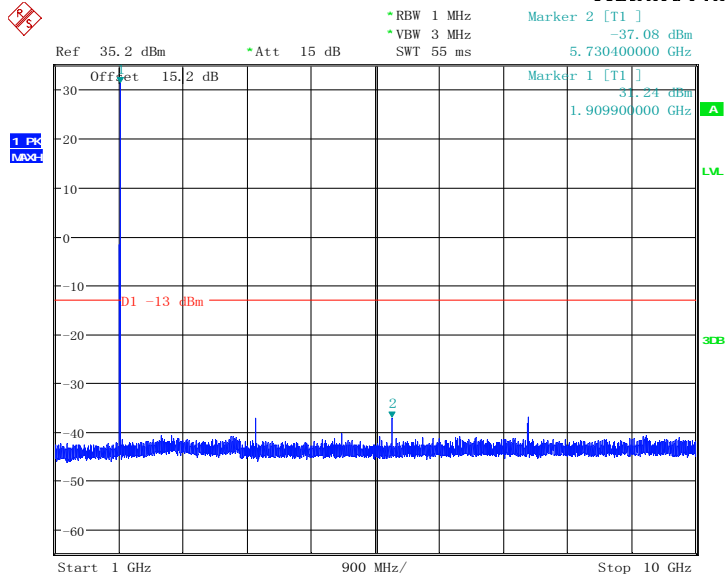

Date: 4. MAY. 2016 17:44:37

GMSK, High channel, 1909.8 MHz, 1GHz to 10GHz

Note: The strong emission shown is the carrier signal.

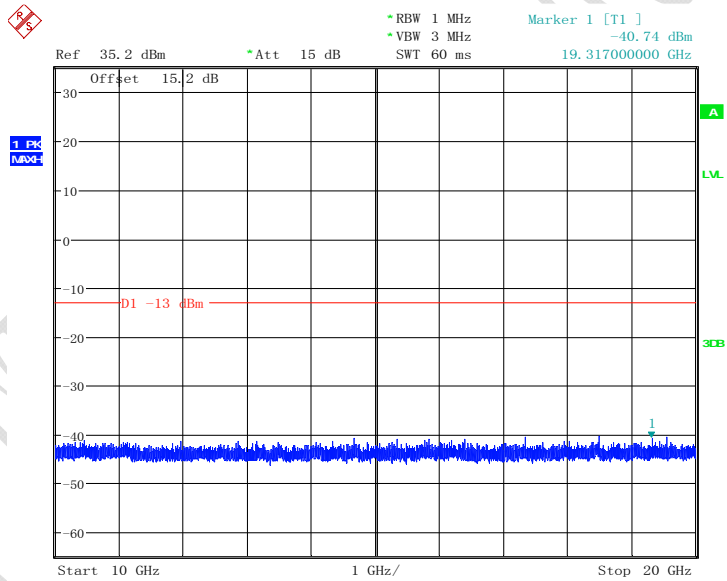

Date: 4. MAY. 2016 17:44:51

GMSK, High channel, 1909.8 MHz, 10GHz to 20GHz

5.3.2 WCDMA Band Mode Conducted Spurious Emission Results Report No.: B16X50165-WWAN_Rev1

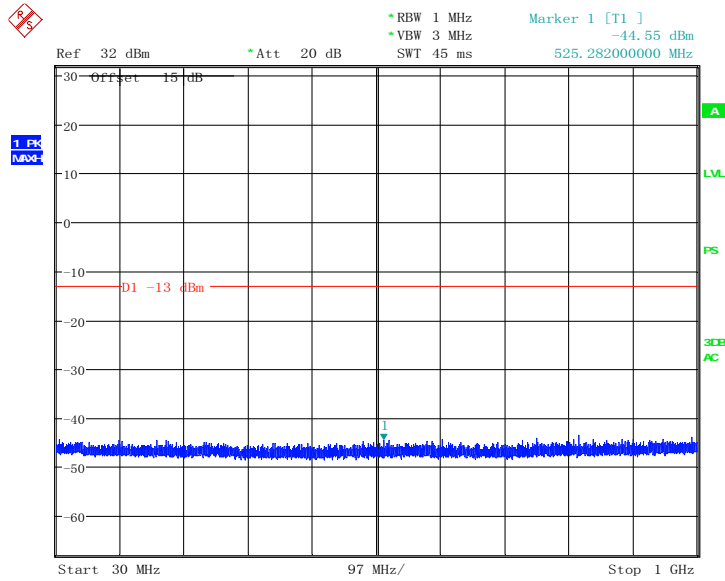

Date: 5. MAY. 2016 17:25:12

WCDMA Band 2 Middle Channel, 1880 MHz, 30MHz to 1GHz

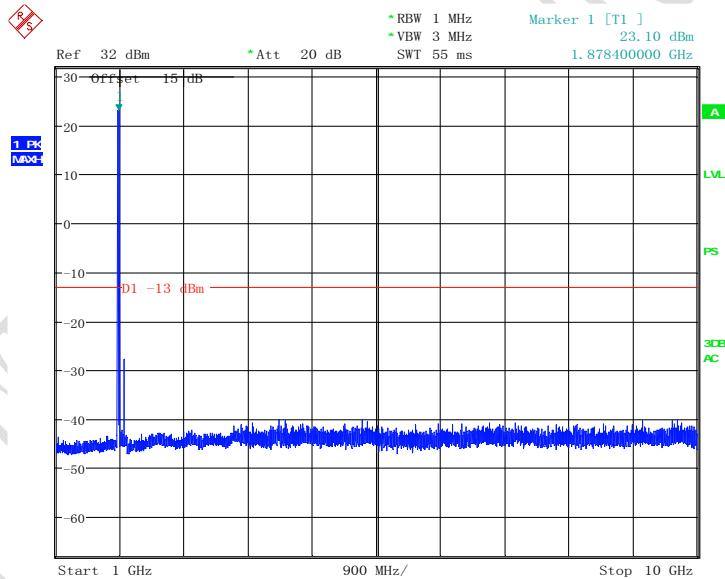

Date: 5. MAY. 2016 17:25:27

WCDMA Band 2 Middle Channel, 1880 MHz, 1GHz to 10GHz

Note: The strong emission shown in each case is the carrier signal.

Report No.: B16X50165-WWAN_Rev1

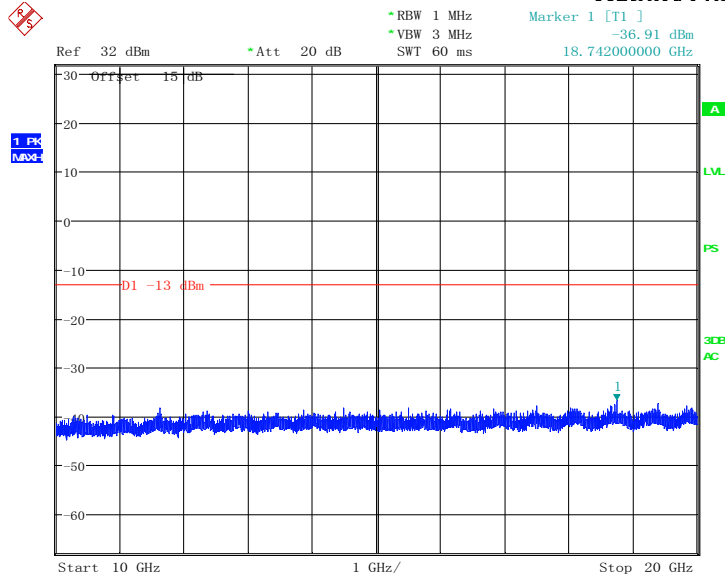

Date: 5.MAY.2016 17:25:53

WCDMA Band 2 Middle Channel, 1880 MHz, 10GHz to 20GHz

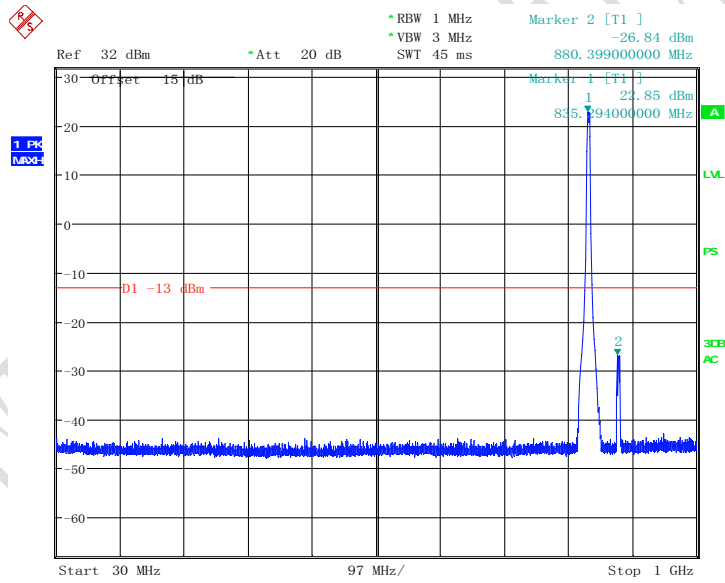

Date: 5.MAY.2016 17:24:07

WCDMA Band 5 Middle Channel, 836.4 MHz, 30MHz to 1GHz

Note: The strong emission shown in each case is the carrier signal.

Report No.: B16X50165-WWAN_Rev1

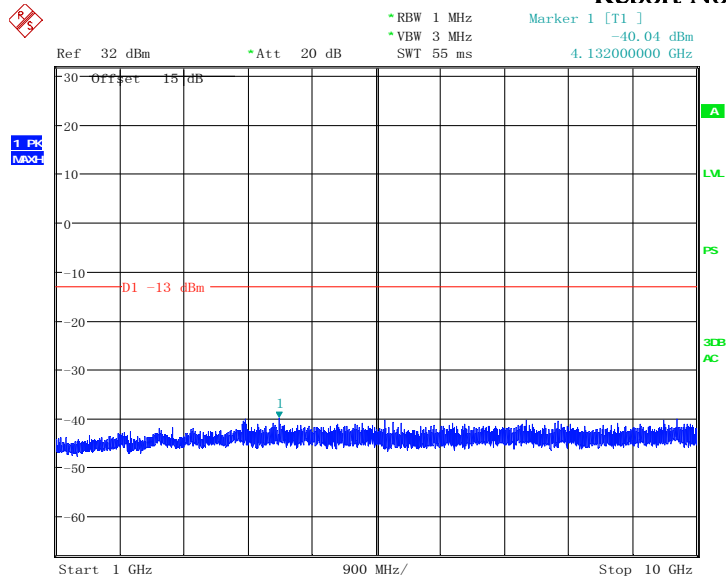

Date: 5. MAY. 2016 17:24:22

WCDMA Band 5 Middle Channel, 836.4 MHz, 1GHz to 10GHz

5.4 Radiated Spurious Emission

Specifications:	FCC Part 2.1051, 24.238, 2.1053, 22.917, 27.53
DUT Serial Number:	S8/10: 358066070000665
Test conditions:	Ambient Temperature:15°C-35°C Relative Humidity:30%-60% Air pressure: 86-106kPa
Test Results:	--

Limit Level Construction:

According to Part 22.917 (a), i.e., Out of band emissions. The power of any emission outside of the authorized operating frequency ranges must be attenuated below the transmitting power (P) by a factor of at least $43 + 10 \log(P)$ dB.

According to Part 24.238 (a), i.e., Out of band emissions. The power of any emission outside of the authorized operating frequency ranges must be attenuated below the transmitting power (P) by a factor of at least $43 + 10 \log(P)$ dB, so the limit level is:

$$P(\text{dBm}) - (43 + 10 \log(P)) \text{ dB} = -13\text{dBm}.$$

According to Part 27.53(h):

Except as otherwise specified below, for operations in the 1695-1710 MHz, 1710-1755 MHz, 1755-1780 MHz, 1915-1920 MHz, 1995-2000 MHz, 2000-2020 MHz, 2110-2155 MHz, 2155-2180 MHz, and 2180-2200 bands, the power of any emission outside a licensee's frequency block shall be attenuated below the transmitter power (P) in watts by at least $43 + 10 \log_{10}(P)$ dB

Test Setup:

The EUT was placed in an anechoic chamber. The Wireless Communications Test Set was used to set the TX channel and power level and modulate the TX signal with different bit patterns.

Test Method:

The measurement method is substitution method accordance with section 2.2.12 of ANSI/TIA-603-D: Land Mobile FM or PM Communications Equipment Measurement and Performance Standards.

(a) Connect the equipment as illustrated and measure the spurious emissions as the method as above.

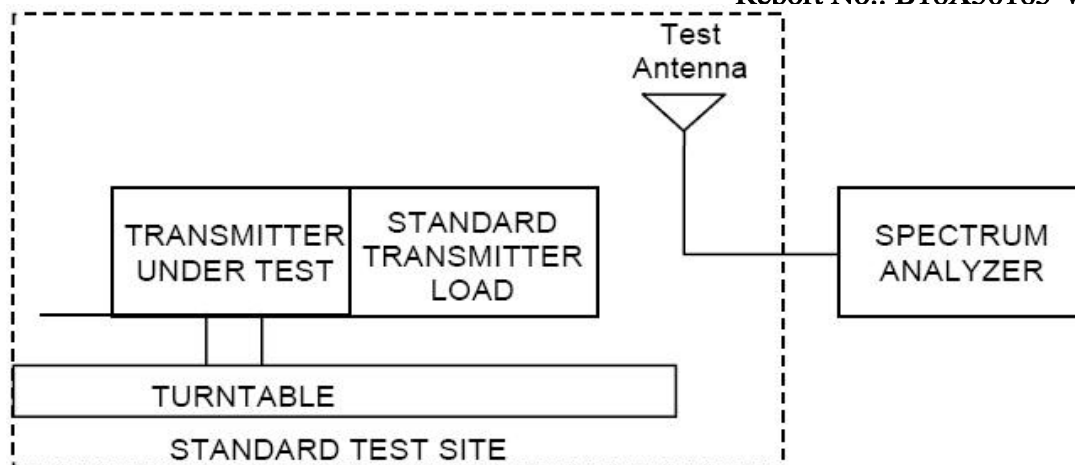

(b) Reconnect the equipment as illustrated.

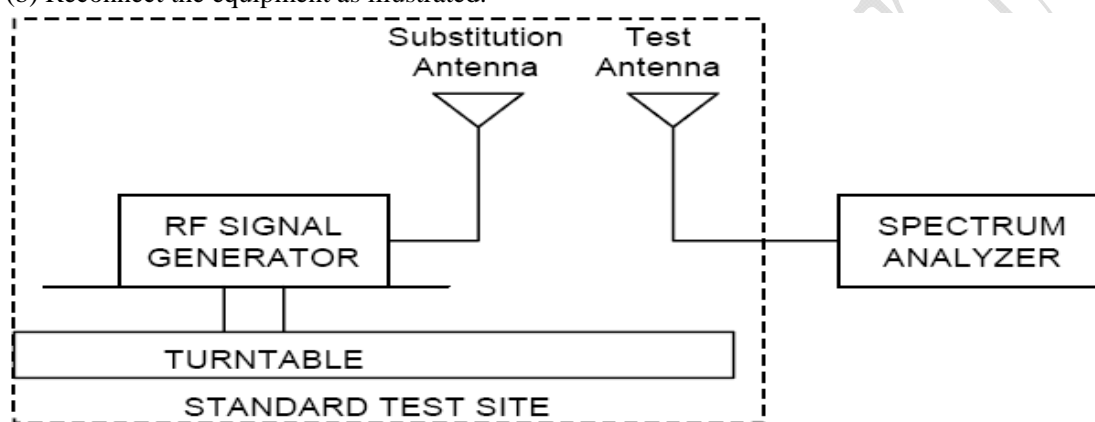

- (c) Remove the transmitter and replace it with a substitution antenna. The center of the substitution antenna should be approximately at the same location as the center of the transmitter.
- (d) Feed the substitution antenna at the transmitter end with a signal generator connected to the antenna by means of a non-radiating cable. With the antennas at both ends horizontally polarized, and with the signal generator tuned to a particular spurious frequency, raise and lower the test antenna to obtain a maximum reading at the spectrum analyzer. Adjust the level of the signal generator output until the previously recorded maximum reading for this set of conditions is obtained. This should be done carefully repeating the adjustment of the test antenna and generator output.
- (e) Repeat step d) with both antennas vertically polarized for each spurious frequency.
- (f) Calculate power in dBm into a reference ideal half-wave dipole antenna by reducing the readings obtained in steps d) and e) by the power loss in the cable between the generator and the antenna, and further corrected for the gain of the substitution antenna used relative to an ideal half-wave dipole antenna by the following formula:

$$P_d(\text{dBm}) = P_g(\text{dBm}) - \text{cable loss (dB)} + \text{antenna gain (dB)}$$

where:

P_d is the dipole equivalent power and

P_g is the generator output power into the substitution antenna.

5.4.1 GSM850 GMSK Radiated Spurious Emission Results

Test Data

Frequency [MHz]	Generator output power(P _g) [dBm]	Cable loss [dB]	Antenna Gain [dB]	Spurious Emission Power (P _d) [dBm]	Antenna Polarization [H/V]
1673.2	-51.36	4.7	9.4	-56.06	V
2509.8	-33.54	5.9	10.6	-38.24	V
3346.4	-57.45	6.9	12.6	-63.15	V
4183.0	-46.93	7.8	12.6	-51.73	V
5019.6	-49.97	7.1	12.7	-55.57	V
1673.2	-47.72	4.7	9.4	-52.42	H
2509.8	-27.18	5.9	10.6	-31.88	H
3346.4	-56.53	6.9	12.6	-62.23	H
4183.0	-45.77	7.8	12.6	-50.57	H
5019.6	-49.73	7.1	12.7	-55.33	H

5.4.2 PCS1900 GMSK Radiated Spurious Emission Results

Test Data

Frequency [MHz]	Generator output power(P _g) [dBm]	Cable loss [dB]	Antenna Gain [dB]	Spurious Emission Power (P _d) [dBm]	Antenna Polarization [H/V]
3760.0	-48.32	7.4	12.6	-53.52	V
5640.0	-47.34	1.8	13.1	-58.64	V
7520.0	-46.48	0.9	11.7	-57.28	V
9400.0	-43.31	0.8	11.9	-54.41	V
11280.0	-48.36	0.3	11.5	-59.56	V
3760.0	-47.36	7.4	12.6	-52.56	H
5640.0	-47.56	1.8	13.1	-58.86	H
7520.0	-47.36	0.9	11.7	-58.16	H
9400.0	-42.01	0.8	11.9	-53.11	H
11280.0	-46.98	0.3	11.5	-58.18	H

5.4.3 WCDMA B2 Radiated Spurious Emission Results

Test Data

Frequency [MHz]	Generator output power(P _g) [dBm]	Cable loss [dB]	Antenna Gain [dB]	Spurious Emission Power (P _a) [dBm]	Antenna Polarization [H/V]
3760.0	-48.36	7.4	12.6	-53.56	V
5640.0	-48.69	1.8	13.1	-59.99	V
7520.0	-47.36	0.9	11.7	-58.16	V
9400.0	-49.56	0.8	11.9	-60.66	V
11280.0	-48.65	0.3	11.5	-59.85	V
3760.0	-47.32	7.4	12.6	-52.52	H
5640.0	-46.25	1.8	13.1	-57.55	H
7520.0	-46.65	0.9	11.7	-57.45	H
9400.0	-45.88	0.8	11.9	-56.98	H
11280.0	-44.35	0.3	11.5	-55.55	H

5.4.4 WCDMA B5 Radiated Spurious Emission Results

Test Data

Frequency [MHz]	Generator output power(P _g) [dBm]	Cable loss [dB]	Antenna Gain [dB]	Spurious Emission Power (P _d) [dBm]	Antenna Polarization [H/V]
1673.2	-53.54	4.7	9.4	-58.24	V
2509.8	-38.53	5.9	10.6	-43.23	V
3346.4	-53.34	6.9	12.6	-59.04	V
4183.0	-54.32	7.8	12.6	-59.12	V
5019.6	-54.12	7.1	12.7	-59.72	V
1673.2	-51.36	4.7	9.4	-56.06	H
2509.8	-32.95	5.9	10.6	-37.65	H
3346.4	-52.36	6.9	12.6	-58.06	H
4183.0	-51.89	7.8	12.6	-56.69	H
5019.6	-51.78	7.1	12.7	-57.38	H

5.5 Band Edge

Specifications:	FCC Part 2.1051, 24.238, 2.1053, 22.917, 27.53
DUT Serial Number:	S3/10: 358066070000178
Test conditions:	Ambient Temperature:15°C-35°C Relative Humidity:30%-60% Air pressure: 86-106kPa
Test Results:	--

Limit Level Construction:

According to Part 22.917 and 24.238:

The power of any emission outside of the authorized operating frequency ranges must be attenuated below the transmitting power (P) by a factor of at least $43 + 10 \log(P)$ dB.

According to Part 27.53(h):

Except as otherwise specified below, for operations in the 1695-1710 MHz, 1710-1755 MHz, 1755-1780 MHz, 1915-1920 MHz, 1995-2000 MHz, 2000-2020 MHz, 2110-2155 MHz, 2155-2180 MHz, and 2180-2200 bands, the power of any emission outside a licensee's frequency block shall be attenuated below the transmitter power (P) in watts by at least $43 + 10 \log_{10}(P)$ dB.

Test Setup:

During the test, the EUT was controlled via the Wireless Communications Test Set to ensure max power transmission and proper modulation and measured by spectrum analyzer.

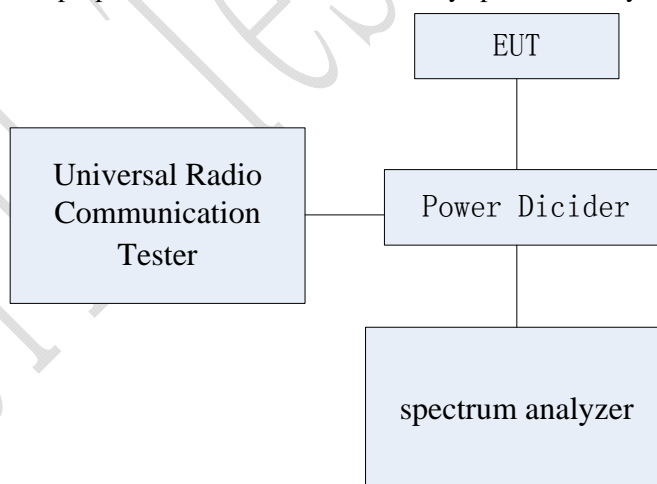

Test Method:

- 1) The EUT was coupled to the EMI test receiver analyzer mode and the base station simulator through a power divider. The loss of the cables the test system is calibrated to correct the readings.
- 2) The spectrum analyzer was set to Maxpeak Detector function and Maximum hold mode.
- 3) The resolution bandwidth of the spectrum analyzer was a little greater than 1% of the 26dB emission bandwidth.

Note: --

5.5.1 GSM850 Band Edge Results

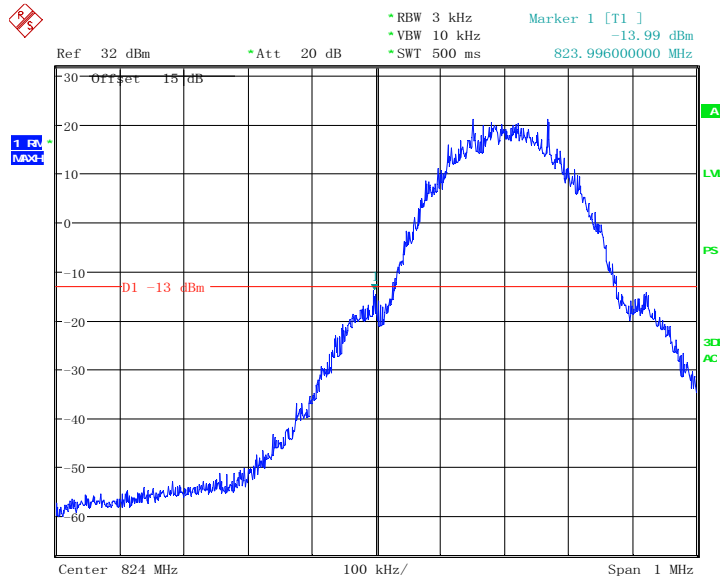

Date: 5. MAY. 2016 15:53:03

GSMK; Cellular low channel, below 824 MHz

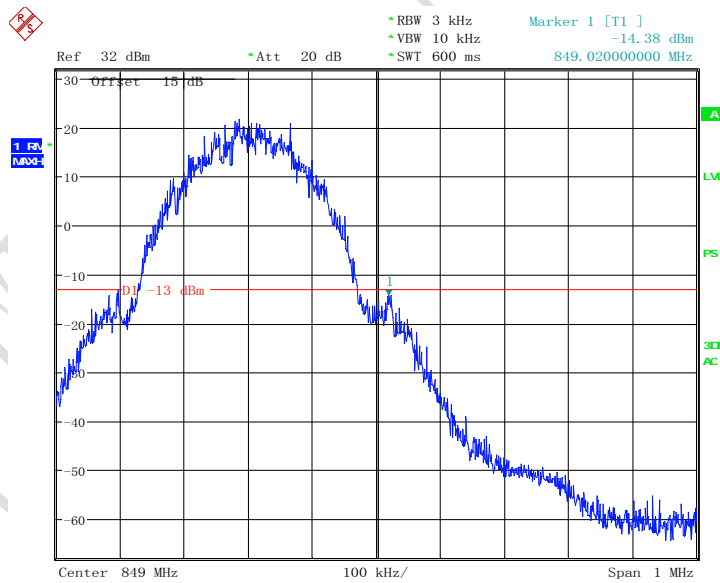

Date: 5. MAY. 2016 16:27:10

GMSK; Cellular high channel, above 849 MHz

5.5.2 PCS1900 Band Edge Results

Report No.: B16X50165-WWAN_Rev1

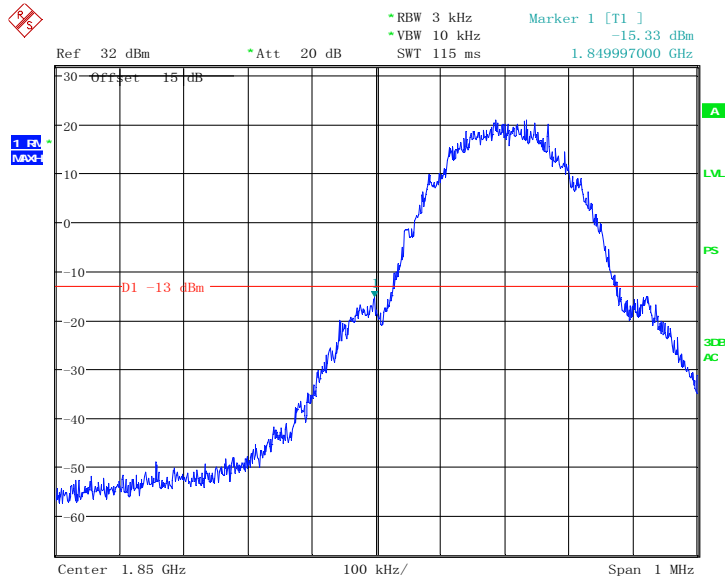

Date: 5. MAY. 2016 16:36:47

GMSK; PCS low channel, below 1850 MHz

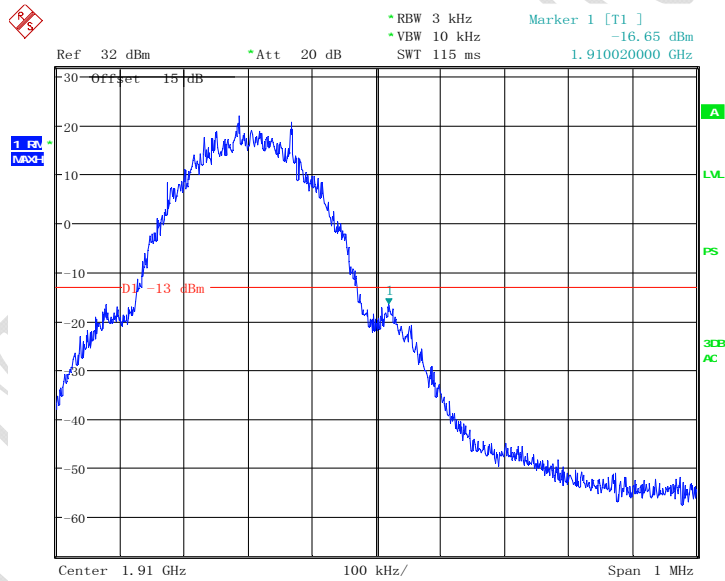

Date: 5. MAY. 2016 16:38:02

GMSK; PCS high channel, above 1910 MHz

5.5.3 WCDMA B2 Band Edge Results

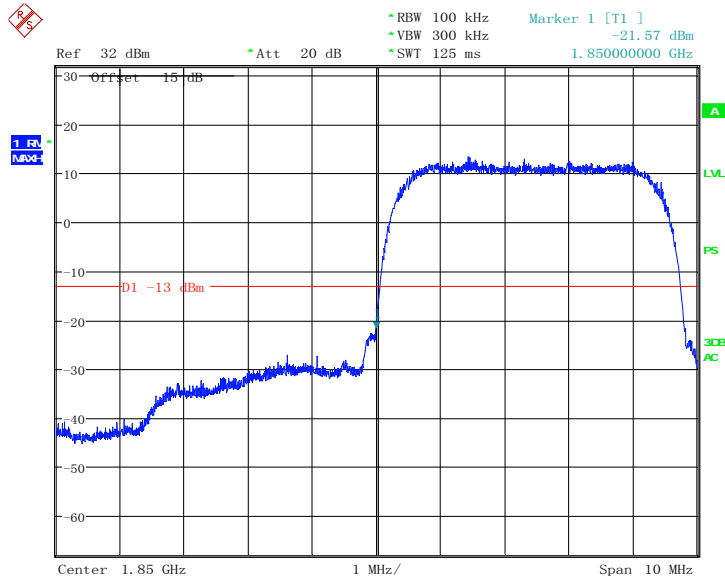

Date: 5. MAY. 2016 17:29:18

WCDMA Band 2 QPSK, Low Channel , Below 1850MHz

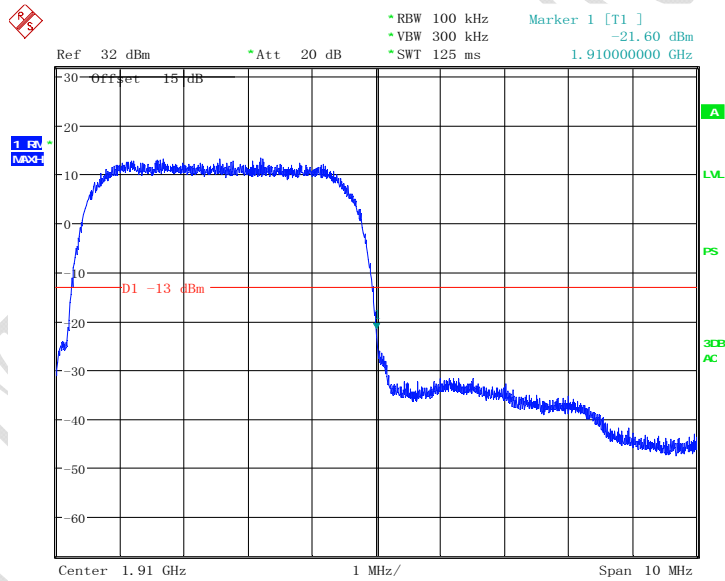

Date: 5. MAY. 2016 17:30:14

WCDMA Band 2 QPSK, High Channel , Above 1910MHz

5.5.4 WCDMA B5 Band Edge Results

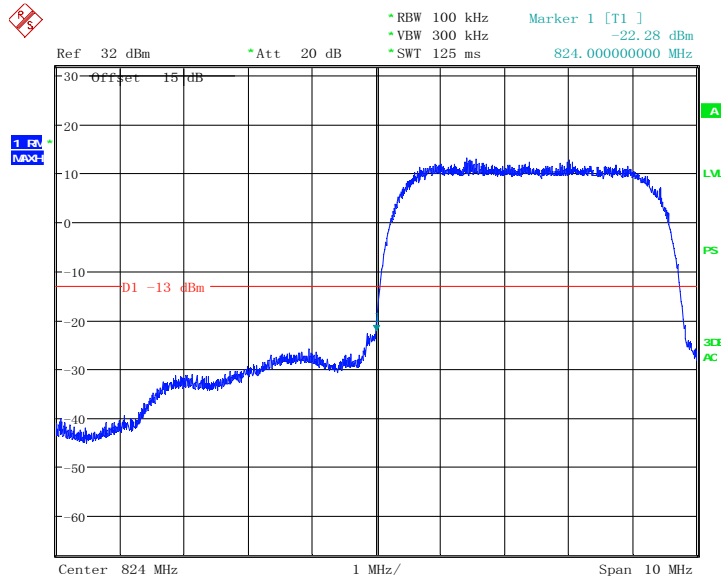

Date: 5. MAY. 2016 17:31:11

WCDMA Band 5 QPSK, Low Channel , Below 824MHz

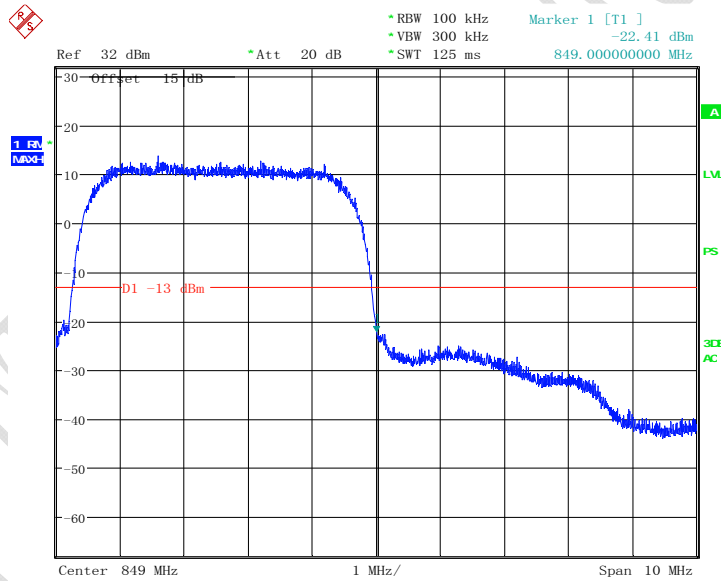

Date: 5. MAY. 2016 17:31:47

WCDMA Band 5 QPSK, High Channel , Above 849MHz

5.6 Frequency Stability over Temperature Variation

Specifications:	FCC Part 2.1055, 22.355, 24.235, 27.54
DUT Serial Number:	S5/10: 358066070000160
Test conditions:	Ambient Temperature:15°C-35°C Relative Humidity:30%-60% Air pressure: 86-106kPa
Test Results:	--

Limit	
Frequency deviation [ppm]	±2.5

Test Setup

The EUT was placed in a temperature chamber, demonstrated as figure T. The Wireless Telecommunications Test Set was used to set the Tx channel and power level, modulate the TX signal with different bit patterns and measure the frequency of Tx.

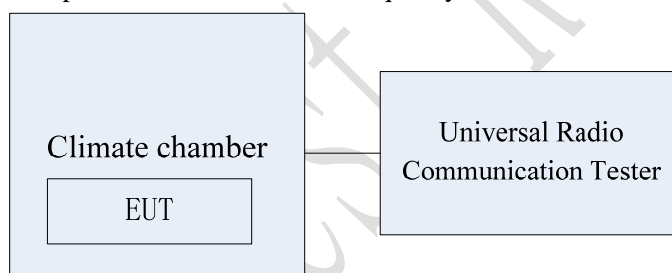

Test Method

- 1、 The EUT was turned off and placed in the temperature chamber.
- 2、 The temperature of the chamber was set to -30°C and allowed to stabilize.
- 3、 The EUT temperature was allowed to stabilize for 45 minutes.
- 4、 The EUT was turned on and set to transmit with Wireless Telecommunications Test Set.
- 5、 The maximum transmit frequency deviation during one minute period was measured by Wireless Communications Test Set.
- 6、 The steps 3-5 were repeated for -30°C, -20°C, -10°C, 0°C, 10°C, 20°C, 30°C, 40°C and 50°C.

5.6.1 GSM Band Frequency Stability over Temperature Variation Results

Band	Offset	Temperature[°C]								
		-30	-20	-10	0	10	20	30	40	50
GSM850 GMSK	Hz	11.25	9.69	10.56	7.23	-6.75	9.69	8.91	-13.54	-15.36
	ppm	0.013	0.011	0.012	0.008	-0.008	0.011	0.010	-0.016	-0.018
PCS1900 GMSK	Hz	29.02	-12.04	-14.01	23.18	15.66	-14.50	-19.61	15.14	20.03
	ppm	0.015	-0.006	-0.007	0.012	0.008	-0.007	-0.010	0.008	0.008

5.6.2 WCDMA Band Frequency Stability over Temperature Variation Results

Band	Offset	Temperature[°C]								
		-30	-20	-10	0	10	20	30	40	50
2	Hz	-4.07	6.72	3.75	2.98	4.26	6.32	4.86	5.06	-3.45
	ppm	-0.004	0.008	0.004	0.003	0.005	0.007	0.005	0.006	-0.004
5	Hz	15.62	18.96	11.27	13.54	12.04	15.47	11.46	14.81	16.53
	ppm	0.008	0.010	0.005	0.007	0.006	0.008	0.006	0.007	0.008

5.7 Frequency Stability over Voltage Variation

Specifications:	FCC Part 2.1055, 22.355, 24.235, 27.54
DUT Serial Number:	S5/10: 358066070000160
Test conditions:	Ambient Temperature:15°C-35°C Relative Humidity:30%-60% Air pressure: 86-106kPa
Test Results:	--

Limit	
Frequency deviation [ppm]	±2.5

Test Setup

The EUT was placed in a shielding chamber and powered by an adjustable power supply, demonstrated as figure V. A Wireless Telecommunications Test Set was used to set the TX channel and power level, modulate the TX signal with different bit patterns and measure the frequency of TX.

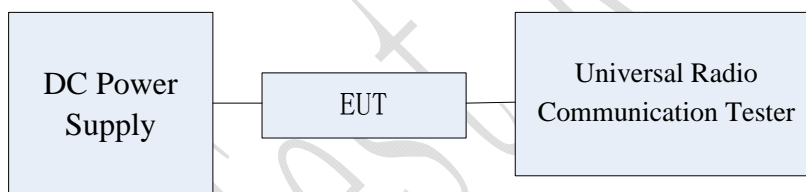

Test Method

The EUT was powered by the adjustable power supply. The frequency stability is measured by the Wireless Telecommunications Test Set.

5.7.1 GSM Band Frequency Stability over Voltage Variation Results

Test data:

Band	Offset	Voltage (V)		
		3.6	3.8	4.2
GSM850 GMSK	Hz	28.54	36.42	19.82
	ppm	0.034	0.043	0.023
PCS1900 GMSK	Hz	26.25	16.56	13.04
	ppm	0.013	0.008	0.008

5.7.2 WCDMA Band Frequency Stability over Voltage Variation Results Report No.: B16X50165-WWAN_Rev1

Test data:

Band	Offset	Voltage (V)		
		3.6	3.8	4.2
2	Hz	31.53	27.43	23.62
	ppm	0.037	0.032	0.028
5	Hz	21.41	27.52	15.32
	ppm	0.011	0.014	0.014

TTL Test Report

5.8 Peak to Average Ratio

Specifications:	FCC Part 24.232, 27.50
DUT Serial Number:	S3/10: 358066070000178
Test conditions:	Ambient Temperature:15°C-35°C Relative Humidity:30%-60% Air pressure: 86-106kPa
Test Results:	--

Limit

The EUT meets the requirement of having a peak to average ratio of less than 13dB.

Test Setup

During the test, the EUT was controlled via the Wireless Communications Test Set to ensure max power transmission and proper modulation and measured by spectrum analyzer.

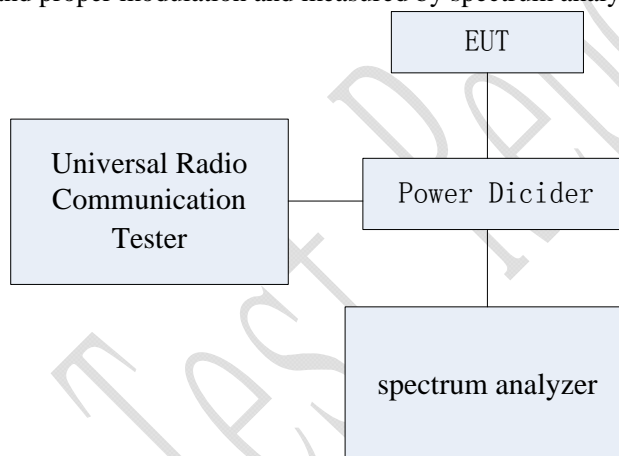

Test Method

The transmitter output was connected to a CMW500 through a coaxial RF cable and directional coupler, and configured to operate at maximum power. The peak to average ratio was measured at the required operating frequencies in each band on the Spectrum Analyzer.

5.8.1 WCDMA B2 Peak to Average Ratio Results

Frequency (MHz)	EUT channel No.	Modulation	Peak to Average Ratio
1880.0	9400	QPSK	3.33

5.8.2 WCDMA B5 Peak to Average Ratio Results

Frequency (MHz)	EUT channel No.	Modulation	Peak to Average Ratio
836.4	4182	QPSK	3.71

Graphical for Peak to Average Ratio Results

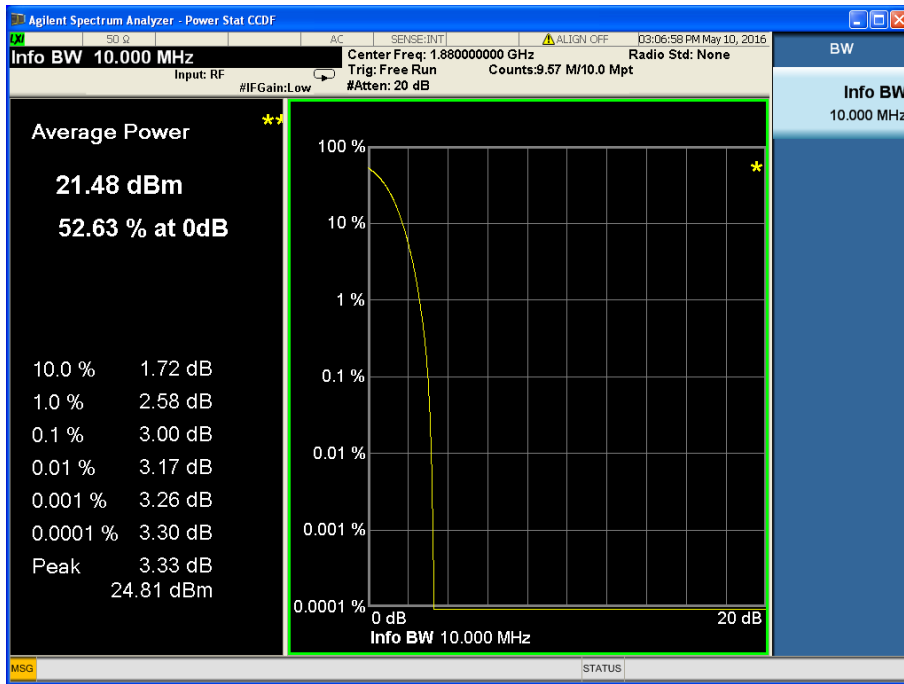

WCDMA Band2, QPSK

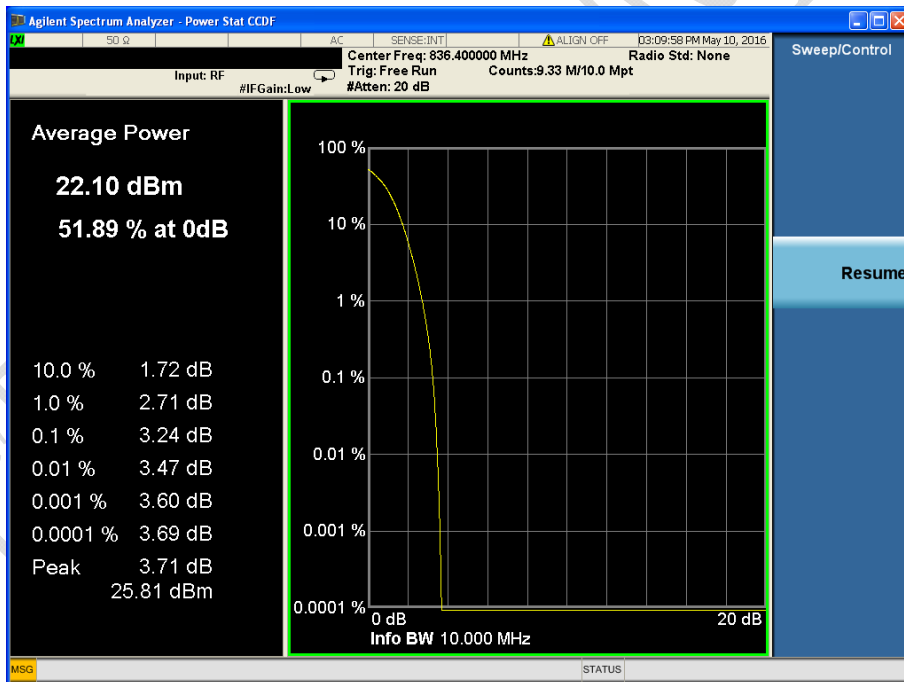

WCDMA Band5, QPSK

5.9 ERP and EIRP

Specifications:	FCC Part 22.913(a), 24.232(b)
DUT Serial Number:	S8/10: 358066070000665
Test conditions:	Ambient Temperature:15°C-35°C Relative Humidity:30%-60% Air pressure: 86-106kPa
Test Results:	--

Limit

Part 22:

According to Part 22.913(a)(2):The ERP of mobile transmitters and auxiliary test transmitters must not exceed 7 Watts.

Part 24:

According to Part 24.232(b):The EIRP of mobile transmitters and auxiliary test transmitters must not exceed 2 Watts.

Test Setup

The EUT was placed in an anechoic chamber. The Communications Test Set was used to set the TX channel and power level and modulate the TX signal with different bit patterns.

Test Method:

The measurement method is substitution method accordance with section 2.2.12 of ANSI/TIA-603-D: Land Mobile FM or PM Communications Equipment Measurement and Performance Standards.

(a) Connect the equipment as illustrated and measure the spurious emissions as the method as above.

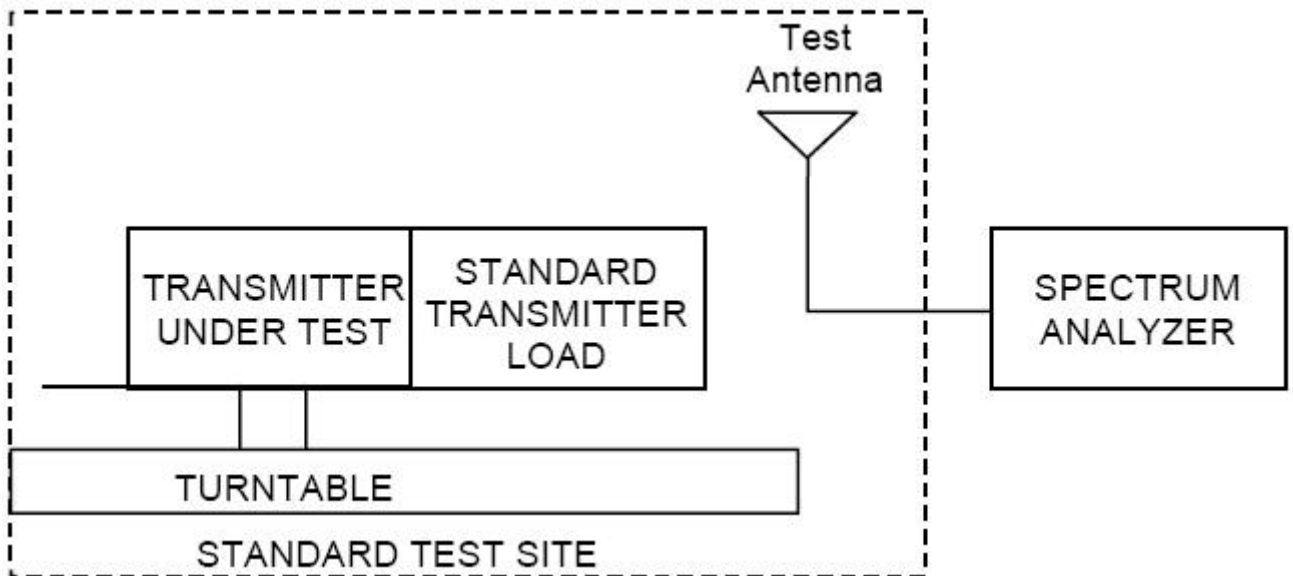

(b) Reconnect the equipment as illustrated.

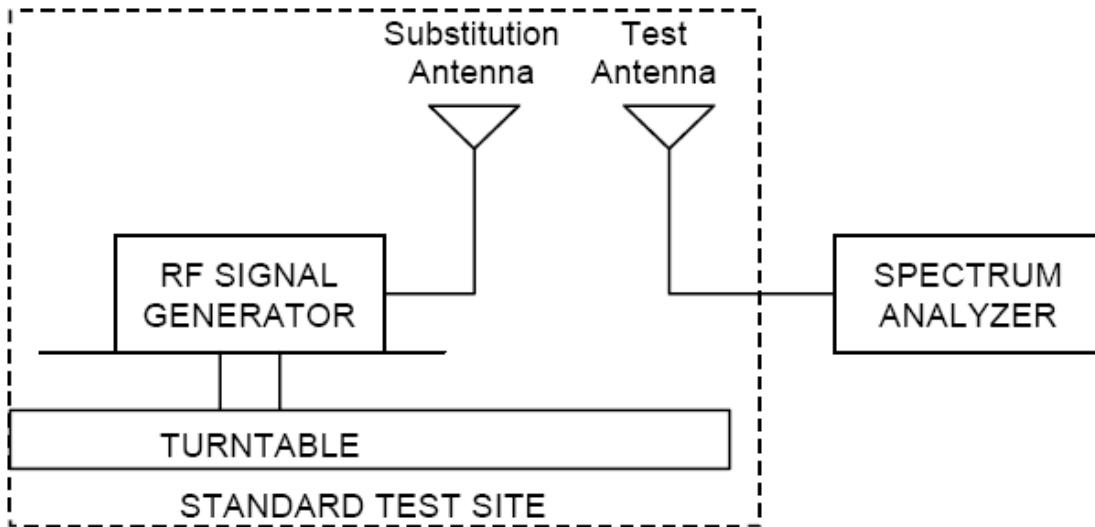

(c) Remove the transmitter and replace it with a substitution antenna. The center of the substitution antenna should be approximately at the same location as the center of the transmitter.

(d) Feed the substitution antenna at the transmitter end with a signal generator connected to the antenna by means of a non-radiating cable. With the antennas at both ends horizontally polarized, and with the signal generator tuned to a particular spurious frequency, raise and lower the test antenna to obtain a maximum reading at the spectrum analyzer. Adjust the level of the signal generator output until the previously recorded maximum reading for this set of conditions is obtained. This should be done carefully repeating the adjustment of the test antenna and generator output.

(e) Repeat step d) with both antennas vertically polarized for each spurious frequency.

(f) Calculate power in dBm into a reference ideal half-wave dipole antenna by reducing the readings obtained in steps d) and e) by the power loss in the cable between the generator and the antenna, and further corrected for the gain of the substitution antenna used relative to an ideal half-wave dipole antenna by the following formula:

$$ERP = S.G \text{ output (dBm)} - \text{cable loss (dB)} + \text{antenna gain (dBd)}$$

$$EIRP = S.G \text{ output (dBm)} - \text{cable loss (dB)} + \text{antenna gain (dBi)}$$

5.9.1 GSM850 GSM Results

Frequency [MHz]	S.G output [dBm]	Cable loss [dB]	Antenna Gain [dB]	ERP (P _d) [dBm]
824.2	24.64	3.4	-2.87	30.91
836.6	24.39	3.4	-3.11	30.90
848.8	23.57	3.4	-3.11	30.08

5.9.2 GSM850 GPRS Results

Frequency [MHz]	S.G output [dBm]	Cable loss [dB]	Antenna Gain [dB]	ERP (P _d) [dBm]
824.2	24.46	3.4	-2.87	30.73
836.6	23.65	3.4	-3.11	30.16
848.8	23.38	3.4	-3.11	29.89

5.9.3 GSM850 EGPRS GMSK Results

Frequency [MHz]	S.G output [dBm]	Cable loss [dB]	Antenna Gain [dB]	ERP (P _d) [dBm]
824.2	23.72	3.4	-2.87	29.99
836.6	23.68	3.4	-3.11	30.19
848.8	23.12	3.4	-3.11	29.63

5.9.4 PCS1900 GSM Results

Frequency [MHz]	S.G output [dBm]	Cable loss [dB]	Antenna Gain [dB]	ERP (P _d) [dBm]
1850.2	33.03	5.0	10.4	27.63
1880.0	33.93	5.0	10.4	28.53
1909.8	33.28	5.1	10.4	27.98

5.9.5 PCS1900 GPRS Results

Frequency [MHz]	S.G output [dBm]	Cable loss [dB]	Antenna Gain [dB]	ERP (P _d) [dBm]
1850.2	33.14	5.0	10.4	27.74
1880.0	33.41	5.0	10.4	28.01
1909.8	33.16	5.1	10.4	27.86

5.9.6 PCS1900 EGPRS GMSK Results

Frequency [MHz]	S.G output [dBm]	Cable loss [dB]	Antenna Gain [dB]	ERP (P _d) [dBm]
1850.2	33.23	5.0	10.4	27.83
1880.0	33.43	5.0	10.4	28.03
1909.8	33.34	5.1	10.4	28.04

5.9.7 WCDMA Band 2 RMC Results

Frequency [MHz]	S.G output [dBm]	Cable loss [dB]	Antenna Gain [dB]	ERP (P _d) [dBm]
1852.5	26.98	5.0	10.4	21.58
1880.0	27.23	5.0	10.4	21.83
1907.6	26.51	5.1	10.4	21.21

5.9.8 WCDMA Band 2 HSDPA Results

Frequency [MHz]	S.G output [dBm]	Cable loss [dB]	Antenna Gain [dB]	ERP (P _d) [dBm]
1852.5	26.22	5.0	10.4	20.82
1880.0	27.10	5.0	10.4	21.70
1907.6	26.09	5.1	10.4	20.79

5.9.9 WCDMA Band 2 HSUPA Results

Frequency [MHz]	S.G output [dBm]	Cable loss [dB]	Antenna Gain [dB]	ERP (P _d) [dBm]
1852.5	26.55	5.0	10.4	21.15
1880.0	27.11	5.0	10.4	21.71
1907.6	26.23	5.1	10.4	20.93

5.9.10 WCDMA Band 5 RMC Results

Frequency [MHz]	S.G output [dBm]	Cable loss [dB]	Antenna Gain [dB]	ERP (P _d) [dBm]
826.4	16.23	3.4	-2.87	22.50
836.4	16.09	3.4	-3.11	22.60
846.4	16.02	3.4	-3.11	22.53

5.9.11 WCDMA Band 5 HSDPA Results

Frequency [MHz]	S.G output [dBm]	Cable loss [dB]	Antenna Gain [dB]	ERP (P _d) [dBm]
824.2	15.87	3.4	-2.87	22.14
836.4	15.79	3.4	-3.11	22.30
848.8	15.45	3.4	-3.11	21.96

5.9.12 WCDMA Band 5 HSUPA Results

Report No.: B16X50165-WWAN_Rev1

Frequency [MHz]	S.G output [dBm]	Cable loss [dB]	Antenna Gain [dB]	ERP (P _d) [dBm]
824.2	14.91	3.4	-2.87	21.18
836.4	14.75	3.4	-3.11	21.26
848.8	14.72	3.4	-3.11	21.23

CITL Test Report

Annex A EUT Photos

See the document "Ilium Pad T7X-External Photos".

See the document "Ilium Pad T7X-Internal Photos".

CTTL Test Report

Report No.: B16X50165-WWAN_Rev1

ANNEX B Deviations from Prescribed Test Methods

No deviation from Prescribed Test Methods.

*****End Of Report*****

CTTL Test Report