



TEST REPORT

REPORT NUMBER: B16X50165-BLE_Rev1

ON

Type of Equipment: Pad
Model Name: Ilium Pad T7X
Manufacturer: Amer Mobile Ltd.,com

ACCORDING TO

FCC Part 15, Subpart C, 2015:

15.207 Conducted limits.

15.209 Radiated emission limits; general requirements.

15.247 Operation within the bands 902–928 MHz, 2400–2483.5 MHz, and 5725–5850 MHz

ANSI C63.10-2013:American National Standard of Procedures for Compliance Testing of Unlicensed Wireless Devices

China Telecommunication Technology Labs.

Month date, year

Jun 08, 2016

Signature



He Guili

Director

Note:

The test results in this test report relate only to the devices specified in this report. This report shall not be reproduced except in full without the written approval of China Telecommunication Technology Labs.

FCC ID: ZC4T7X
Report Date: 2016-06-08

Test Firm Name: China Telecommunication Technology Labs
FCC Registration Number: 840587

Statement

The measurements shown in this report were made in accordance with the procedures described on test pages. All reported tests were carried out on a sample equipment to demonstrate limited compliance with FCC Parts 15, subpart C. The sample tested was found to comply with the requirements defined in the applied rules.

CONTENTS

1 GENERAL INFORMATION	4
1.1 NOTES.....	4
1.2 TESTERS.....	5
1.3 TESTING LABORATORY INFORMATION	6
1.4 DETAILS OF APPLICANT OR MANUFACTURER.....	7
2 TEST ITEM	8
2.1 GENERAL INFORMATION	8
2.2 OUTLINE OF EQUIPMENT UNDER TEST	8
2.3 MODIFICATIONS INCORPORATED IN EUT.....	8
2.4 EQUIPMENT CONFIGURATION	8
2.5 OTHER INFORMATION	8
3 SUMMARY OF TEST RESULTS.....	9
4 TEST EQUIPMENTS AND ANCILLARIES USED FOR TESTS.....	10
5 TEST RESULTS	11
5.1 MAXIMUM PEAK OUTPUT POWER.....	11
5.2 PEAK POWER SPECTRAL DENSITY	12
5.3 6DB OCCUPIED BANDWIDTH	16
5.4 BAND EDGES COMPLIANCE	19
5.5 TRANSMITTER SPURIOUS EMISSION-CONDUCTED	21
5.6 TRANSMITTER SPURIOUS EMISSION-RADIATED	26
5.7 POWER LINE CONDUCTED EMISSIONS	33
ANNEX A EUT PHOTOS	36
ANNEX B DEVIATIONS FROM PRESCRIBED TEST METHODS	37

1 General Information

1.1 Notes

All reported tests were carried out on a sample equipment to demonstrate limited compliance with FCC Parts 15, subpart C and ANSI C63.10-2013 and FCC DA 00-705.

The test results of this test report relate exclusively to the item(s) tested as specified in section 2.

The following deviation from, additions to, or exclusions from the test specifications have been made. See Annex C.

China Telecommunication Technology Labs.(CTTL) authorizes the applicant or manufacturer (see section 1.4) to reproduce this report provided, and the test report may only be reproduced or published in full. Reproduction or publication of extracts from the report requires the prior written approval of director of CTTL Mr. He Guili.

Any use which a third party makes of this report, or any reliance on or decisions to be made based on it, are the responsibility of such third parties. CTTL accepts no responsibility for damages, if any, suffered by any third party as a result of decisions made or actions based on this report.

1.2 Testers

Name: Li Guoqing
Position: Engineer
Department: Department of RF test
Date: 2016-05-03 to 2016-06-08
Signature: 李国庆

Editor of this test report:

Name: Li Guoqing
Position: Engineer
Department: Department of RF test
Date: 2016-06-08
Signature: 李国庆

Technical responsibility for area of testing:

Name: Zou Dongyi
Position: Manager
Department: Director of the laboratory
Date: 2016-06-08
Signature: 邹东屹

1.3 Testing Laboratory information

1.3.1 Location

Name: China Telecommunication Technology Labs.
Address: No. 11, Yue Tan Nan Jie, Xi Cheng District
BEIJING
P. R. CHINA, 100083
Tel: +86 10 68094053
Fax: +86 10 68011404
Email: emc@chinattl.com

1.3.2 Details of accreditation status

Accredited by: China National Accreditation Service for Conformity
Assessment (CNAS)
Registration number: CNAS Registration No. CNAS L0570
Standard: ISO/IEC 17025:2005

1.3.3 Test location, where different from section 1.3.1

Name: -----
Street: -----
City: -----
Country: -----
Telephone: -----
Fax: -----
Postcode: -----

1.4 Details of applicant or manufacturer

1.4.1 Applicant

Name: Corporativo Lanix S.A.de C.V.
Address: Carretera Internacional Hermosillo - Nogales Km 8.5
Hermosillo, Sonora, México
Country: México
Telephone: 0052 16621090811
Fax: --
Contact: Oscar Guzman
Email: oguzman@lanix.com

1.4.2 Manufacturer (if different from applicant in section 1.4.1)

Name: Amer Mobile Ltd.,com
Address: 17/F, Tower B, Huihai Sqr, Chuangye Rd, Longhua Dist,
Shenzhen, China
Country: China
Telephone: 86 13421844861
Fax: --
Contact: Windy.Chen
Email: chengang841230@163.com

2 Test Item

2.1 General Information

Manufacturer: Amer Mobile Ltd.,com
 Type of Equipment: Pad
 Model Name: Ilium Pad T7X
 Serial Number: S4/10: 358066070000145
 S8/10: 358066070000665
 Production Status: Product
 Receipt date of test item: 2016-05-03

2.2 Outline of Equipment under Test

The Ilium Pad T7X, referred to as “EUT” hereafter, is a multi-band wireless modem operating on the GSM/UMTS networks. The table below shows the supported bands for the EUT.

Technology	Band	UL Freq.(MHz)	DL Freq.(MHz)	Note
GSM	GSM850	824 - 849	869 - 894	--
	PCS1900	1850 - 1910	1930 - 1990	--
WCDMA	B2	1850 - 1910	1930 - 1990	--
	B5	824 - 849	869 - 894	--

2.3 Modifications Incorporated in EUT

The EUT has not been modified from what is described by the brand name and unique type identification stated above.

2.4 Equipment Configuration

Equipment configuration list:

Item	Generic Description	Manufacturer	Type	Serial No.	Remarks
A	Modem	Amer Mobile Ltd.,com	Ilium Pad T7X	S4/10: 358066070000145 S8/10: 358066070000665	None
B	Adaptor	None	None	--	None

2.5 Other Information

--

3 Summary of Test Results

A brief summary of the tests carried out is shown as following.

FCC Rules	Name of Test	Result
15.247(b)(1)	Maximum Peak Output Power	Pass
15.247(e)	Peak Power Spectral Density	Pass
15.247(a)(2)	6dB Occupied Bandwidth	Pass
15.247(d)	Band Edges Compliance	Pass
15.247 (d)	Transmitter Spurious Emission-Conducted	Pass
15.247(d), 15.209(a)	Transmitter Spurious Emission-Radiated	Pass
ANSI C63.4 voltage mains test	Power line Conducted Emissions	Pass

4 Test Equipments and Ancillaries Used For Tests

The test equipments and ancillaries used are as follows.

No.	Equipment	Model	SN	Manufacture	Cal. Due Date
1	EMI Test Receiver	ESU26	100367	R&S	2017-03-04
2	Trilog super broadband test antenna	VULB 9163	9163-544	R&S	2017-01-05
3	Double-Ridged Horn Antenna	HF907	100356	R&S	2016-12-12
4	Fully-Anechoic Chamber	11.8m×6.5 m×6.3m	--	ETS	2017-08-19
5	Universal Radio Communication Tester	CMW500	128181	R&S	2017-03-04
6	Signal Generator	SMU200A	104517	R&S	2017-03-04
7	spectrum analyzer	FSQ 26	201137/026	R&S	2017-03-04
8	Climate chamber	SH-241	92010759	ESPEC	2017-03-04
9	DC Power Supply	N6705B	MY50000919	Agilent	2017-12-06

5 Test Results

5.1 Maximum Peak Output Power

Specifications:	FCC Part 15.247(b)(1)
DUT Serial Number:	S4/10: 358066070000145
Test conditions:	Ambient Temperature: 15°C - 35°C Relative Humidity: 30% - 60% Air pressure: 86 - 106 kPa
Test Results:	Pass

Limit Level Construction:

The maximum peak output power of the intentional radiator shall not exceed the following:

1. For systems using digital modulation in the bands of 902 - 928 MHz, 2400 - 2483.5 MHz, and 5725 - 5850 MHz: 1 watt.
2. Except as shown in paragraphs (b)(3) (i), (ii) and (iii) of this section, if transmitting antennas of directional gain greater than 6 dBi are used the peak output power from the intentional radiator shall be reduced below the stated values in paragraphs (b)(1) or (b)(2) of this section, as appropriate, by the amount in dB that the directional gain of the antenna exceeds 6 dBi.

Test Method:

The measurement is according to ANSI C63.10 clause 11.2

1. The output power of EUT was connected to the spectrum analyzer. The path loss was compensated to the results for each measurement.
2. Enable EUT transmitter maximum power continuously.
3. Set RBW \geq OBW, Set the appropriate VBW
4. Detector : Peak.
5. Trace mode: Max Hold

Note: --

Measurement Results:

Channel No.	Output Power (dBm)	Limit (dBm)	Result
Low: 0	-9.85	30	Pass
Middle: 19	-10.69		Pass
High: 39	-11.08		Pass

Conclusion: PASS

5.2 Peak Power Spectral Density

Specifications:	FCC CFR Part 15.247(e)
DUT Serial Number:	S4/10: 358066070000145
Test conditions:	Ambient Temperature:15°C-35°C Relative Humidity:30%-60% Air pressure: 86-106kPa
Test Results:	--

Limit Level Construction:

Standard	Limit
FCC CFR Part 15.247(e)	< 8dBm/3 KHz

Test procedure:

The measurement is according to ANSI C63.10 clause 11.10.

1. The output power of EUT was connected to the spectrum analyzer. The path loss was compensated to the results for each measurement.
2. Enable EUT transmitter maximum power continuously.
3. Set analyzer center frequency to DTS channel center frequency.
4. Set the span to 1.5 times the DTS bandwidth.
5. Set the RBW to $3\text{ kHz} \leq \text{RBW} \leq 100\text{ kHz}$.
6. Set the VBW $\geq [3 \times \text{RBW}]$.
7. Detector = peak.
8. Sweep time = auto couple.
9. Trace mode = max hold.
10. Allow trace to fully stabilize.
11. Use the peak marker function to determine the maximum amplitude level within the RBW.
12. If measured value exceeds requirement, then reduce RBW (but no less than 3 kHz) and repeat.

Note: --

Test Results:

Power Spectral Density(dBm/3kHz)			Conclusion
Ch0	Ch19	Ch39	
-24.79	-25.66	-26.09	Pass
Power Spectral Density(dBm/100kHz)			Conclusion
Ch0	Ch19	Ch39	
-10.18	-11.07	-11.51	Pass

Test figure as below:

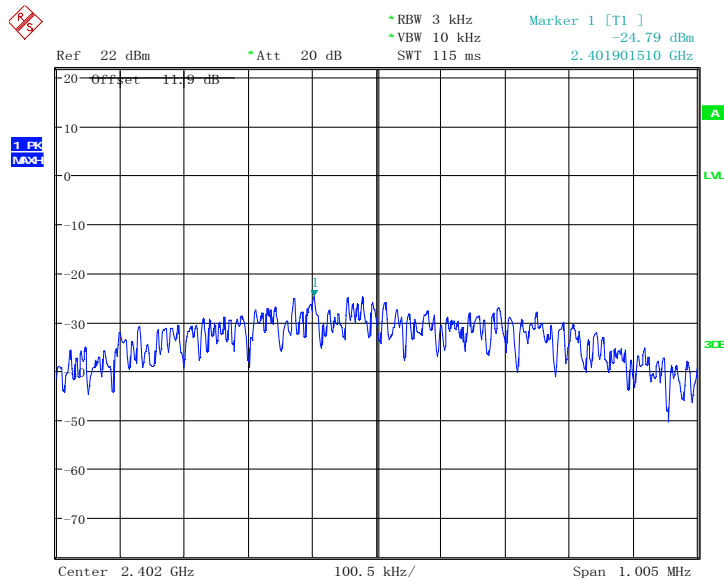

Date: 9. MAY. 2016 10:50:32

Fig.1 Power spectral density: CH0 PSD/3KHz

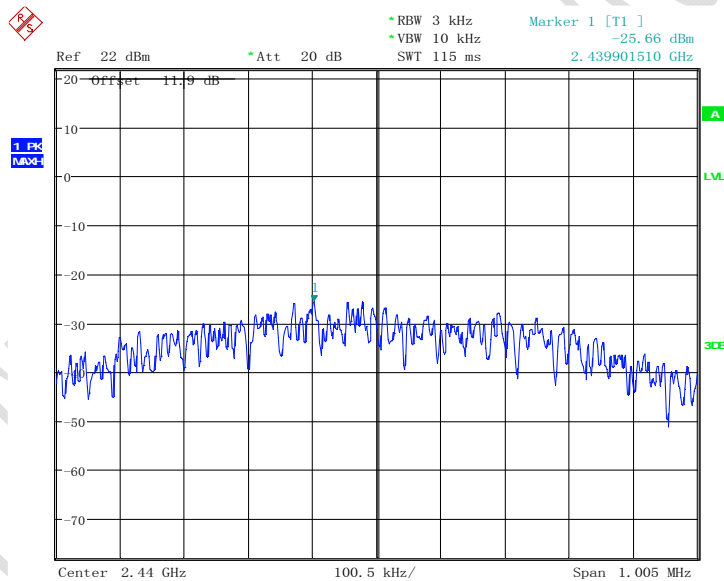

Date: 9. MAY. 2016 10:51:00

Fig.2 Power spectral density: CH19 PSD/3KHz

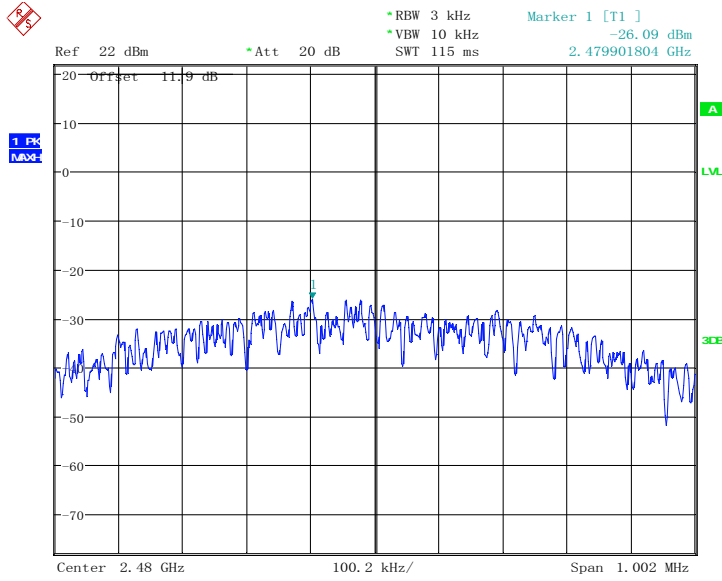

Date: 9. MAY. 2016 10:56:20

Fig.3 Power spectral density: CH39 PSD/3KHz

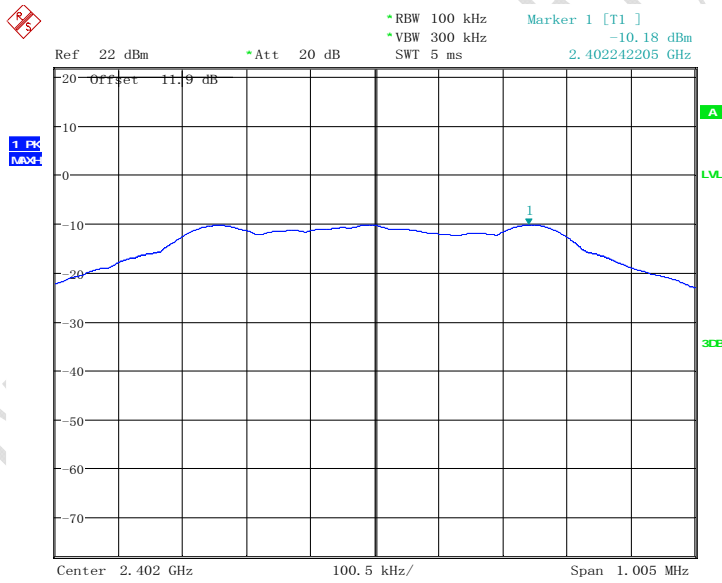

Date: 9. MAY. 2016 10:50:10

Fig.4 Power spectral density: CH0 PSD/100KHz

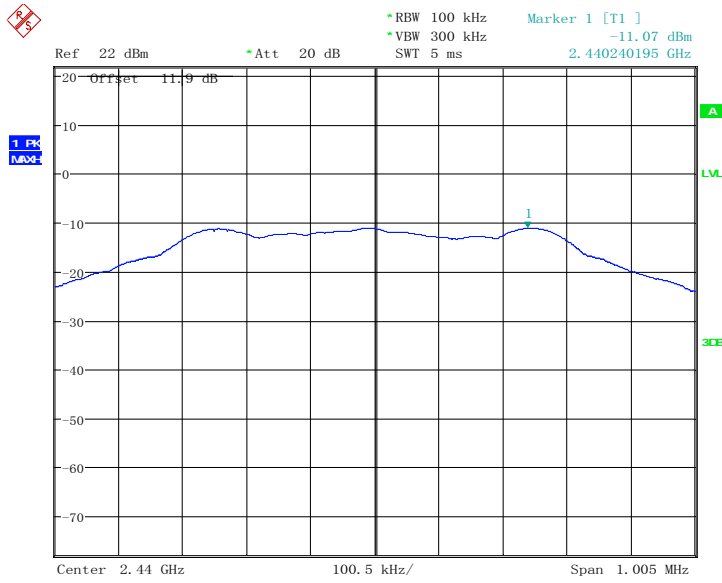

Date: 9. MAY. 2016 10:51:18

Fig.5 Power spectral density: CH19 PSD/100KHz

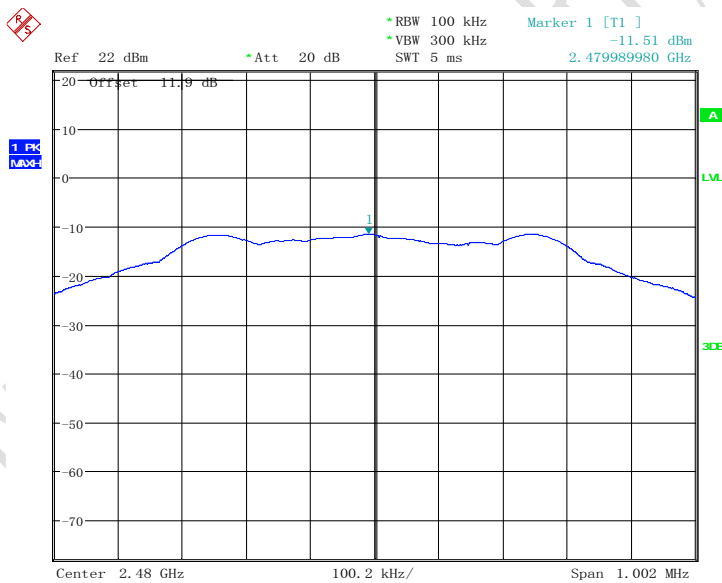

Date: 9. MAY. 2016 10:56:08

Fig.6 Power spectral density: CH39 PSD/100KHz

5.3 6dB Occupied Bandwidth

Specifications:	FCC 47 CFR Part 15.247(a)(2)
DUT Serial Number:	S4/10: 358066070000145
Test conditions:	Ambient Temperature:15°C-35°C Relative Humidity:30%-60% Air pressure: 86-106kPa
Test Results:	--

Limit Level Construction:

Standard	Limit(KHz)
FCC 47 CFR Part 15.247(a)	≥500

Test Procedure

The measurement is according to ANSI C63.10 clause 11.8.

1. The output power of EUT was connected to the spectrum analyzer. The path loss was compensated to the results for each measurement.
2. Enable EUT transmitter maximum power continuously.
3. Set RBW = 100 kHz.
4. Set the VBW ≥ [3 × RBW].
5. Detector = peak.
6. Trace mode = max hold.
7. Sweep = auto couple.
8. Allow the trace to stabilize.
9. Measure the maximum width of the emission that is constrained by the frequencies associated with the two outermost amplitude points (upper and lower frequencies) that are attenuated by 6 dB relative to the maximum level measured in the fundamental emission.

Note: --

Test Result:

Occupied 6dB Bandwidth(MHz)			Conclusion
Ch0	Ch19	Ch39	
0.708	0.721	0.715	Pass

Conclusion: PASS

Test figure as below:

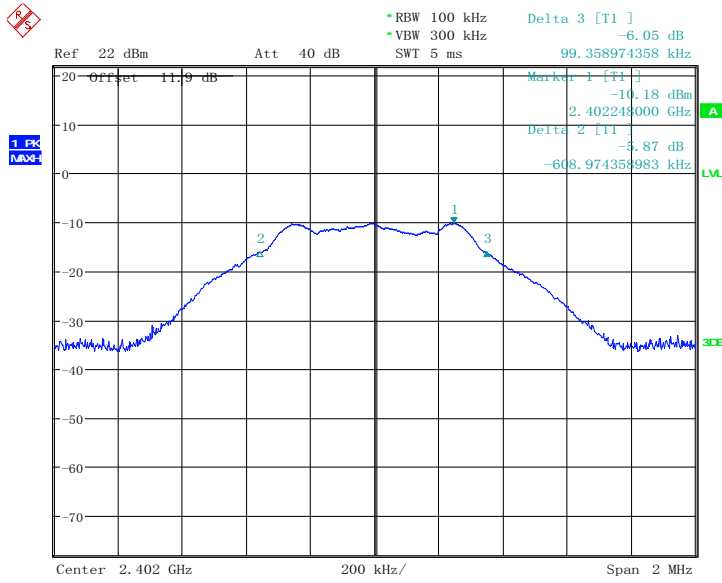

Date: 9. MAY. 2016 10:09:56

Fig.7 6dB Bandwidth: Ch0

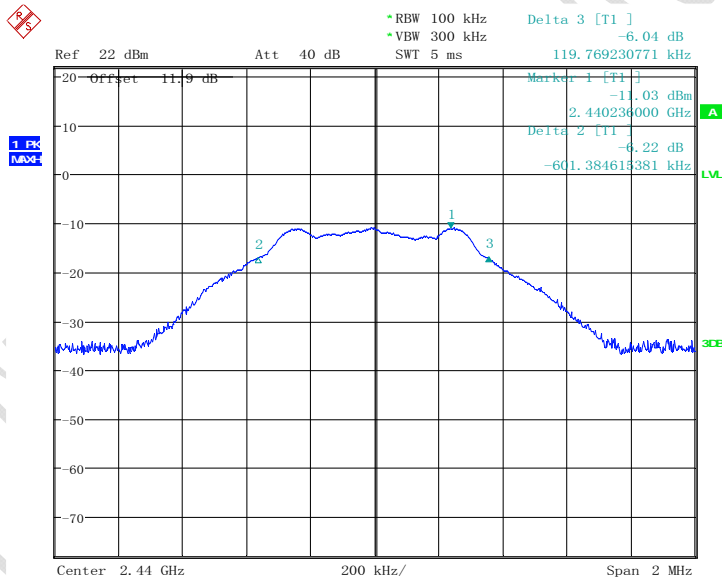

Date: 9. MAY. 2016 10:11:25

Fig.8 6dB Bandwidth: Ch19

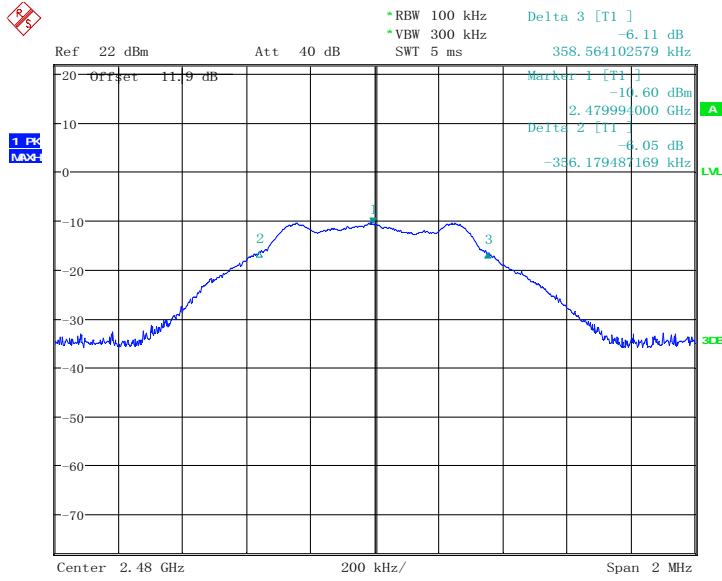

Date: 9.MAY.2016 10:12:53

Fig.9 6dB Bandwidth: Ch39

5.4 Band Edges Compliance

Specifications:	FCC 47 CFR Part 15.247(d)
DUT Serial Number:	S4/10: 358066070000145
Test conditions:	Ambient Temperature:15°C-35°C Relative Humidity:30%-60% Air pressure: 86-106kPa
Test Results:	--

Limit Level Construction:

According to §15.247(d), in any 100 kHz bandwidth outside the frequency band in which the spread spectrum or digitally modulated intentional radiator is operating, the radio frequency power that is produced by the intentional radiator shall be at least 20 dB below that in the 100 kHz bandwidth within the band that contains the highest level of the desired power, based on either an RF conducted or a radiated measurement, provided the transmitter demonstrates compliance with the peak conducted power limits.

The BLUETOOTH TESTER was used to set the TX channel and power level. The transmitter output is connected to Spectrum analyzer through a coupling.

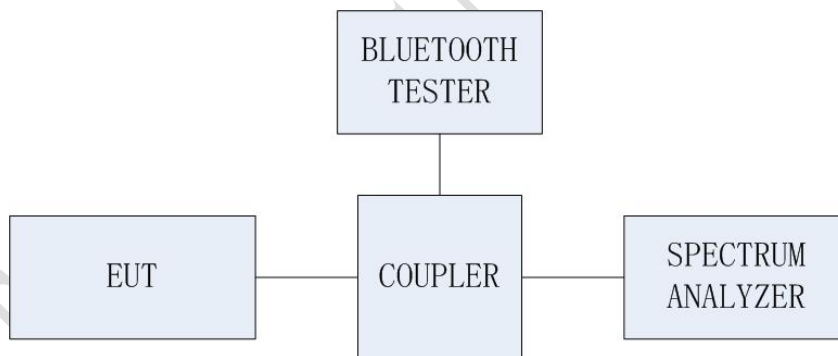

Test procedure:

The transmitter output is connected to the Spectrum Analyzer. The Spectrum Analyzer is set to the peak detector mode. The spectrum analyzer is set to:

1. Span = 10 MHz
2. RBW = 100 KHz
3. VBW = 300 KHz
4. Sweep = auto

The measurement is made according to Public notice FCC Public Notice DA 00-705, March 2000, and ANSI C63.4-2003.

Note: --

Test Result:

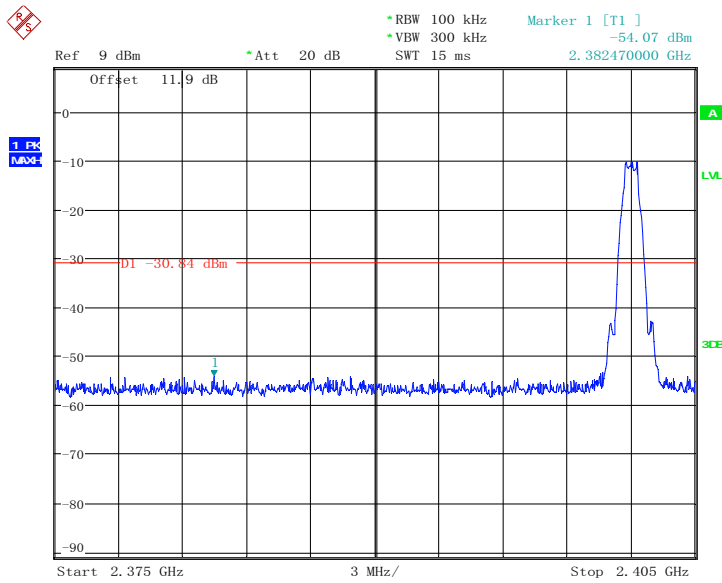

Date: 9. MAY. 2016 15:41:27

Fig.10 Frequency Band Edge: Ch0

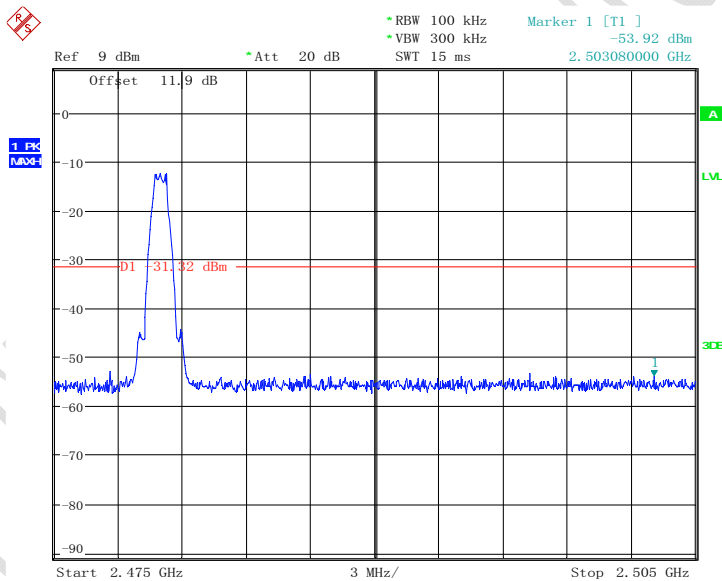

Date: 9. MAY. 2016 15:43:20

Fig.11 Frequency Band Edge: Ch39

Conclusion: PASS

5.5 Transmitter Spurious Emission-Conducted

Specifications:	FCC 47 CFR Part 15.247 (d)
DUT Serial Number:	S4/10: 358066070000145
Test conditions:	Ambient Temperature:15°C-35°C Relative Humidity:30%-60% Air pressure: 86-106kPa
Test Results:	--

Limit

Standard	Limit
FCC 47 CFR Part15.247 (d)	20dB below peak output power in 100KHz bandwidth

Test Procedure

This measurement is according to ANSI C63.10 clause 11.11.

1. The output power of EUT was connected to the spectrum analyzer. The path loss was compensated to the results for each measurement.
2. Enable EUT transmitter maximum power continuously.

Reference level measurement

3. Set instrument center frequency to DTS channel center frequency.
4. Set the span to ≥ 1.5 times the DTS bandwidth.
5. Set the RBW = 100 kHz.
6. Set the VBW $\geq [3 \times \text{RBW}]$.
7. Detector = peak.
8. Sweep time = auto couple.
9. Trace mode = max hold.
10. Allow trace to fully stabilize.
11. Use the peak marker function to determine the maximum PSD level.

Emission level measurement

12. Set the center frequency and span to encompass frequency range to be measured.
13. Set the RBW = 100 kHz.
14. Set the VBW $\geq [3 \times \text{RBW}]$.
15. Detector = peak.
16. Sweep time = auto couple.
17. Trace mode = max hold.
18. Allow trace to fully stabilize.
19. Use the peak marker function to determine the maximum amplitude level.

Test Result:

Channel	Frequency Range	Test Results	Conclusion
0	30MHz~3GHz	Fig.12	Pass
	3GHz~26.5GHz	Fig.13	Pass
19	30MHz~3GHz	Fig.14	Pass
	3GHz~26.5GHz	Fig.15	Pass
39	30MHz~3GHz	Fig.16	Pass
	3GHz~26.5GHz	Fig.17	Pass

Conclusion: PASS

Test figure as below:

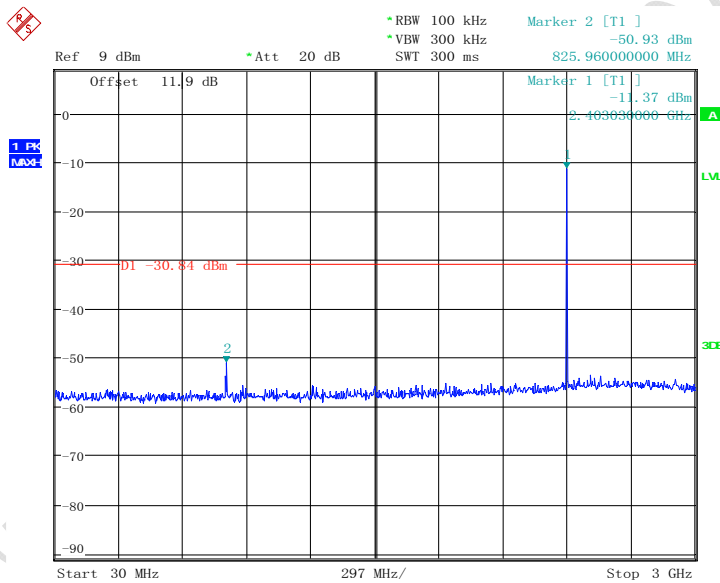

Date: 9.MAY.2016 15:46:56

Fig.12 Conducted spurious emission: Ch0, 30MHz~3GHz

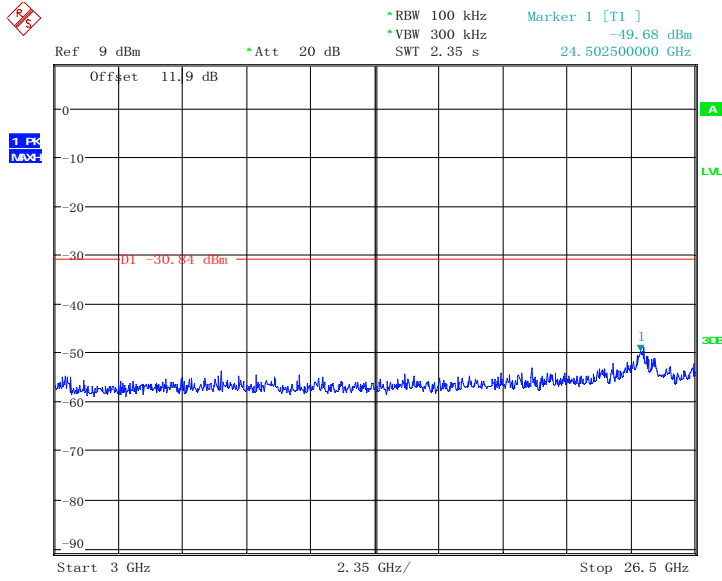

Date: 9.MAY.2016 15:47:56

Fig.13 Conducted spurious emission: Ch0, 3GHz~26.5GHz

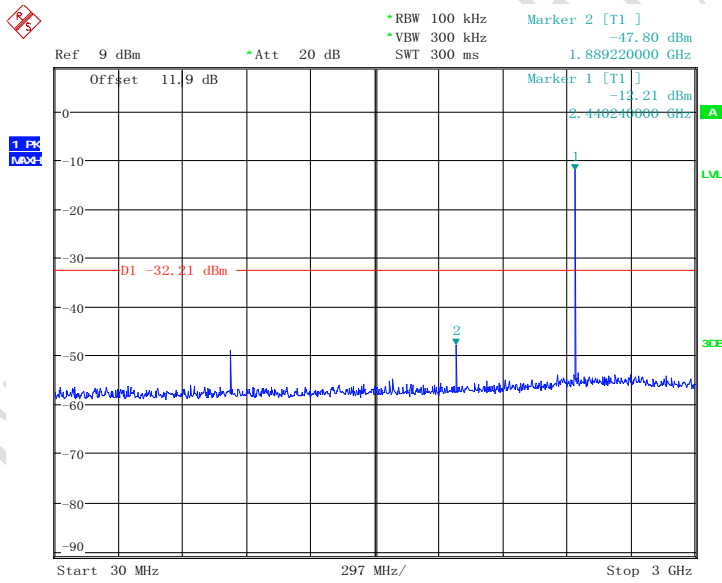

Date: 9.MAY.2016 15:51:28

Fig.14 Conducted spurious emission: Ch19, 30MHz~3GHz

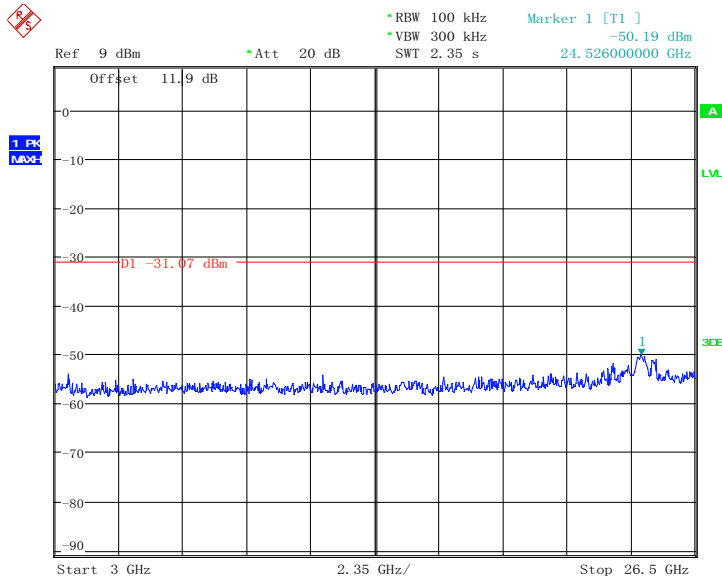

Date: 9.MAY.2016 16:11:43

Fig.15 Conducted spurious emission: Ch19, 3GHz~26.5GHz

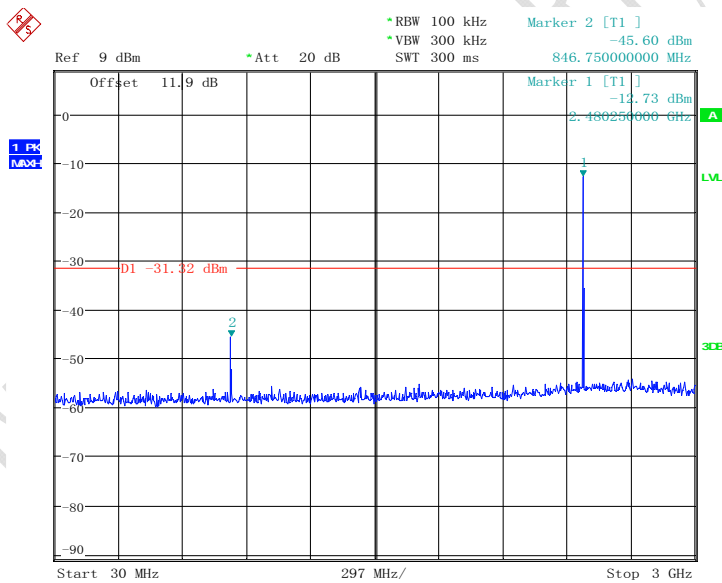

Date: 9.MAY.2016 15:53:55

Fig.16 Conducted spurious emission: Ch39, 30MHz~3GHz

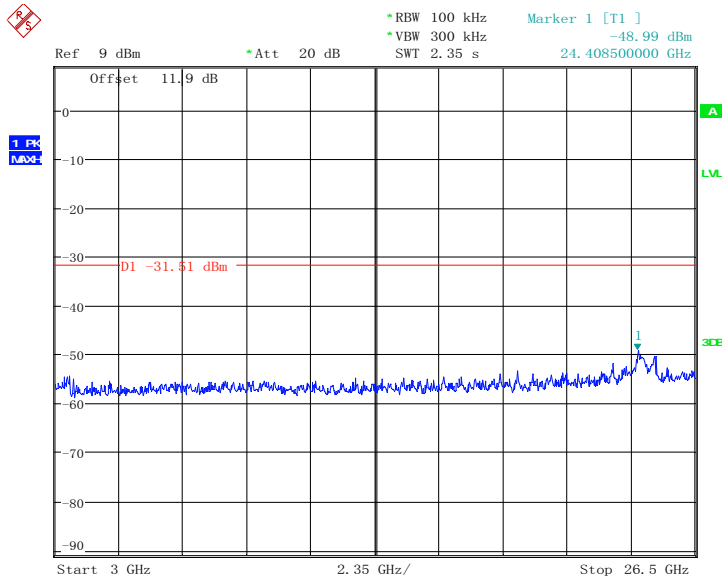

Date: 9.MAY.2016 16:13:06

Fig.17 Conducted spurious emission: Ch39, 3GHz~26.5GHz

5.6 Transmitter Spurious Emission-Radiated

Specifications:	FCC 47 CFR Part 15.247(d), 15.209(a)
DUT Serial Number:	S8/10: 358066070000665
Test conditions:	Ambient Temperature:15°C-35°C Relative Humidity:30%-60% Air pressure: 86-106kPa
Test Results:	--

Limit

Standard	Limit
FCC 47 CFR Part 15.247, 15.205, 15.209	20dB below peak output power

In addition, radiated emissions which fall in the restricted bands, as defined in 15.205(a), must also comply with the radiated emission limits specified in 15.209(a) (see 15.205(c)).

Limit in restricted band:

Frequency of emission (MHz)	Field strength (uV/m)	Field strength (dBuV/m)
30~88	100	40
88~216	150	43.5
216~960	200	46
Above 960	500	54

Test Procedure

Portable, small, lightweight, or modular devices that may be handheld, worn on the body, or placed on a table during operation shall be positioned on a non-conducting platform, the top of which is 80 cm above the reference ground plane. The preferred area occupied by the EUT arrangement is 1 m by 1.5 m, but it may be larger or smaller to accommodate various sized EUTs. For testing purposes, ceiling- and wall-mounted devices also shall be positioned on a tabletop (see also ANSI C63.10-2013 section 6.3.4 and 6.3.5). In making any tests involving handheld, body-worn, or ceiling-mounted equipment, it is essential to recognize that the measured levels may be dependent on the orientation (attitude) of the three orthogonal axes of the EUT. Thus, exploratory tests as specified in 8.3.1 shall be carried out for various axes orientations to determine the attitude having maximum or near-maximum emission level.

The EUT was placed on a non-conductive table. The measurement antenna was placed at a distance of 3 meters from the EUT. During the tests, the antenna height and the EUT azimuth were varied in order to identify the maximum level of emissions from the EUT. This maximization process was repeated with the EUT positioned in each of its three orthogonal orientations.

Frequency of emission (MHz)	RBW/VBW	Sweep Time (s)
30~1000	100KHz/300KHz	5
1000~4000	1MHz/1MHz	15
4000~18000	1MHz/1MHz	40
18000~26500	1MHz/1MHz	20

Test Result:

A “reference path loss” is established and AR_{pi} is the attenuation of “reference path loss”, and including the gain of receive antenna , the gain of the preamplifier, the cable loss.

The measurement results are obtained as described below:

$$AR_{pi} = \text{Cable loss} + \text{Antenna Gain} - \text{Preamplifier gain}$$

$$\text{Result} = P_{Mea} + AR_{pi}$$

Channel	Frequency Range	Test Results	Conclusion
Ch0	30MH-1GHz	Fig.18	Pass
	1GHz-3GHz	Fig.19	Pass
	3GHz-18GHz	Fig.20	Pass

Channel	Frequency Range	Test Results	Conclusion
Ch19	30MH-1GHz	Fig.21	Pass
	1GHz-3GHz	Fig.22	Pass
	3GHz-18GHz	Fig.23	Pass

Channel	Frequency Range	Test Results	Conclusion
Ch39	30MH-1GHz	Fig.24	Pass
	1GHz-3GHz	Fig.25	Pass
	3GHz-18GHz	Fig.26	Pass
All channels	18GHz-26GHz	Fig.27	Pass

Note: all the test data shown was peak detected.

Conclusion: PASS

Test graphs as below:

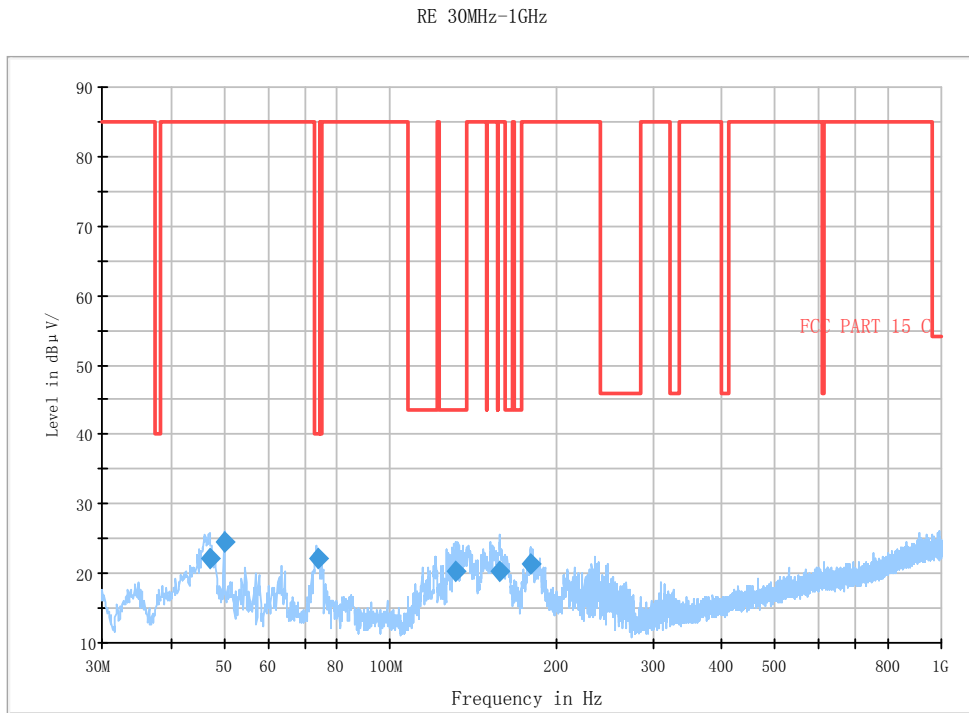

Fig.18 Radiated emission: Ch0, 30MHz-1GHz

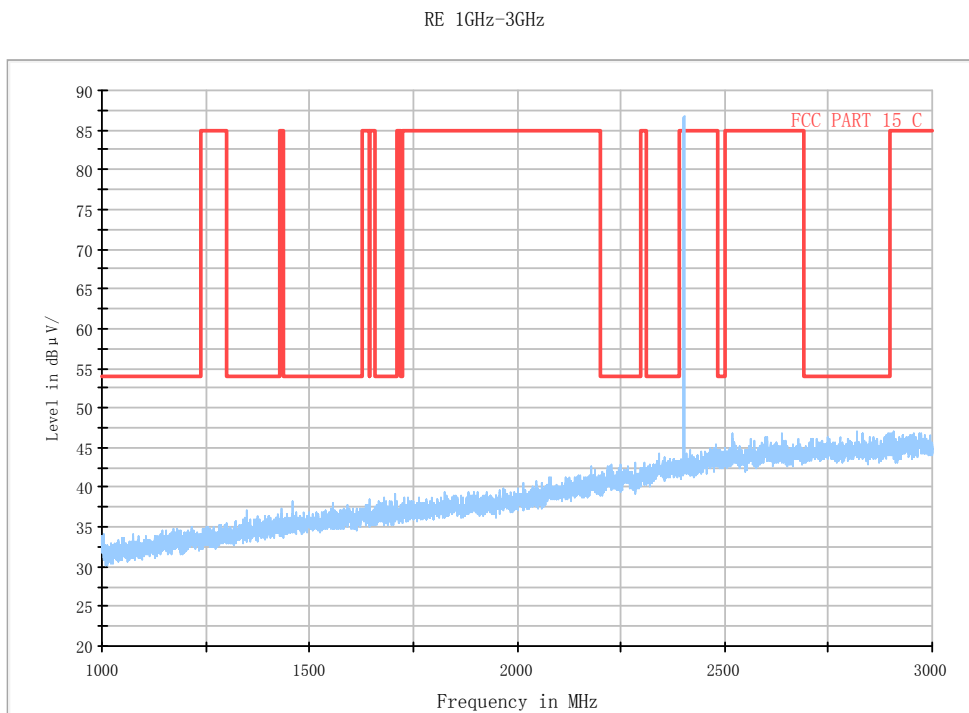

Fig.19 Radiated emission: Ch0, 1GHz-3GHz

RE 3GHz-18GHz

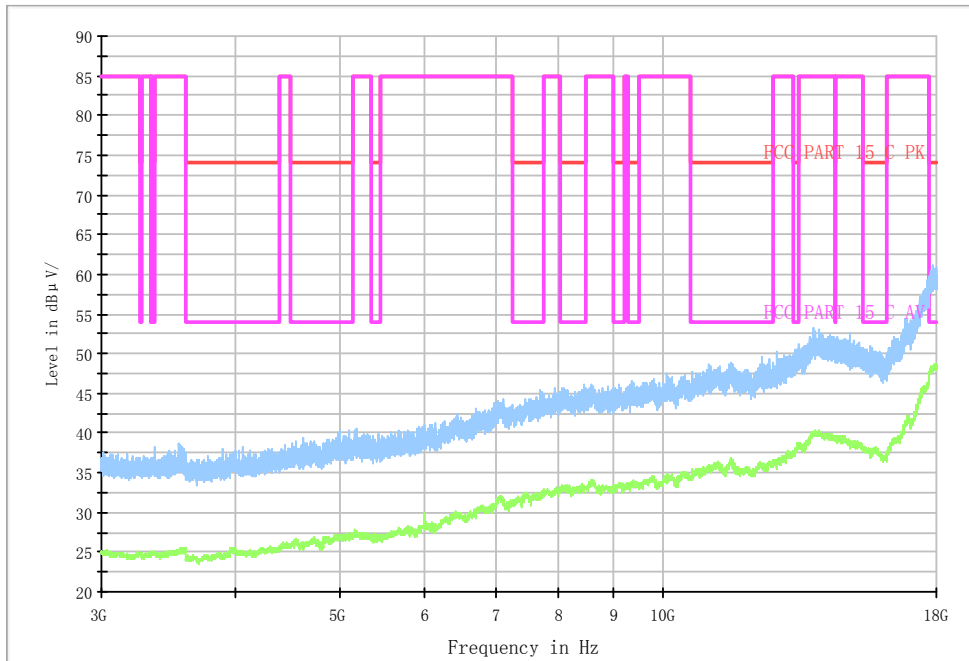

Fig.20 Radiated emission: Ch0, 3GHz-18GHz

RE 30MHz-1GHz

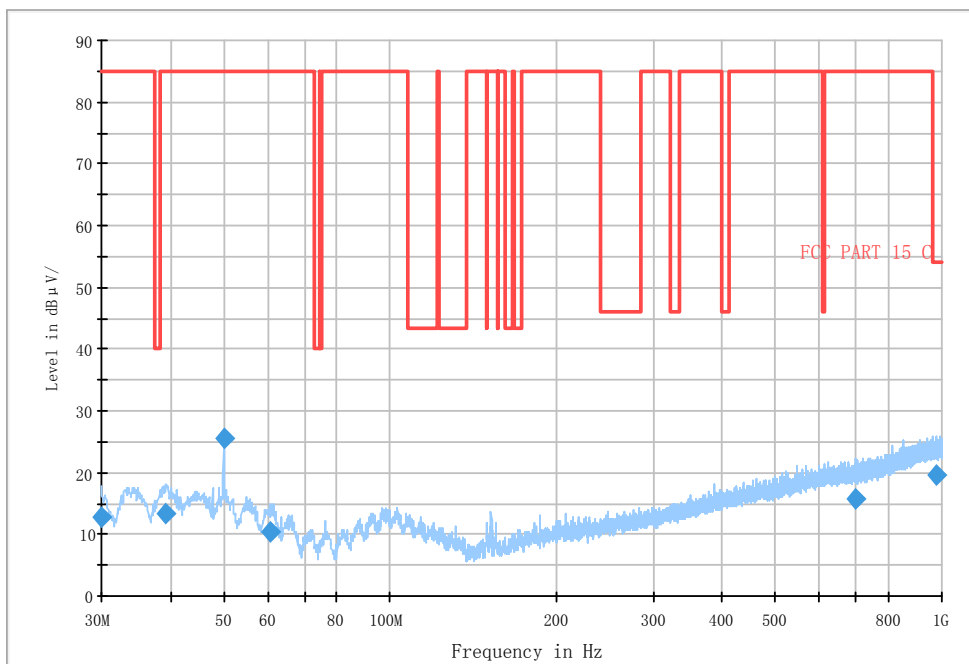

Fig.21 Radiated emission Ch19, 30MHz-1GHz

RE 1GHz-3GHz

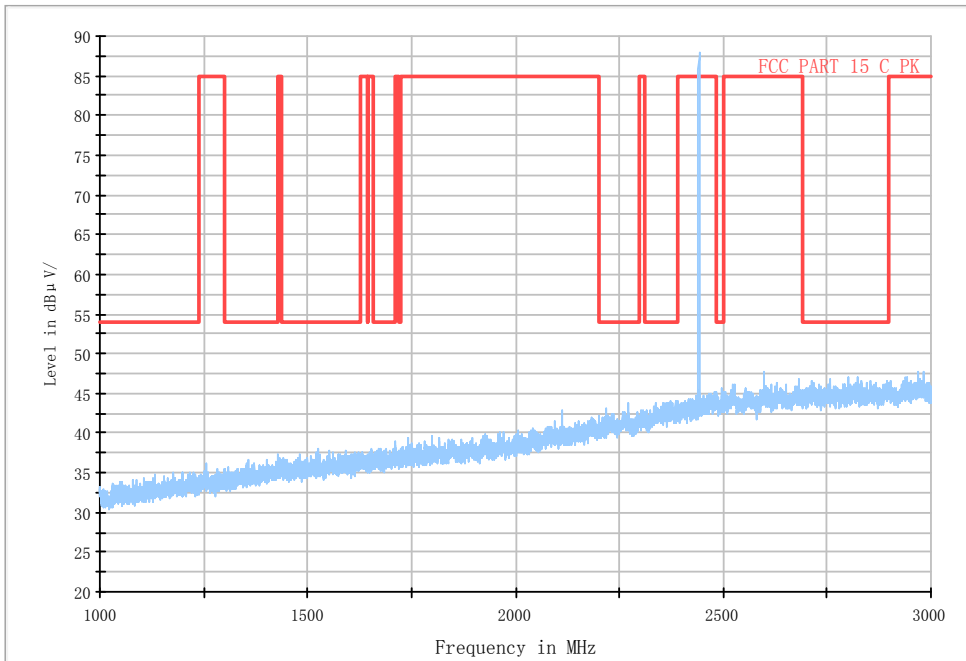

Fig.22 Radiated emission: Ch19, 1GHz-3GHz

RE 3GHz-18GHz

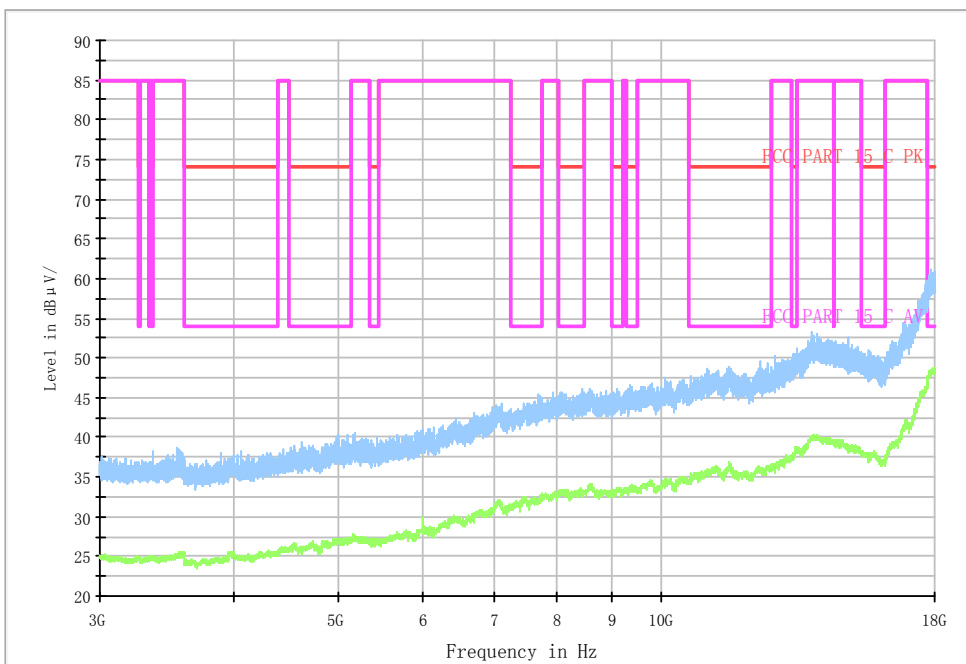

Fig.23 Radiated emission: Ch19, 3GHz-18GHz

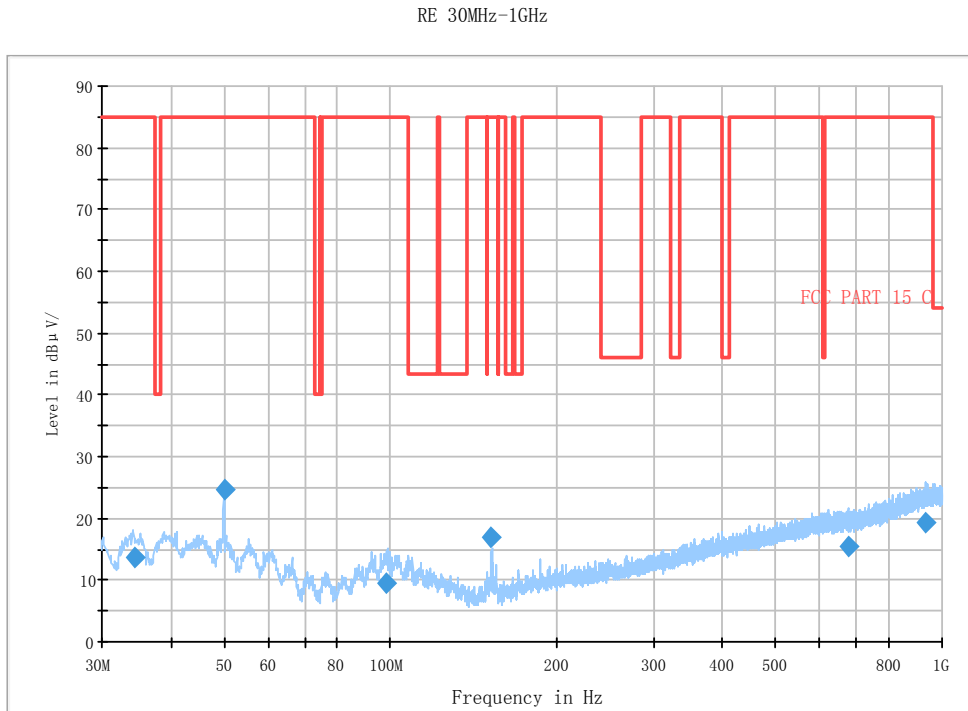

Fig.24 Radiated emission: Ch39, 30MHz-1GHz

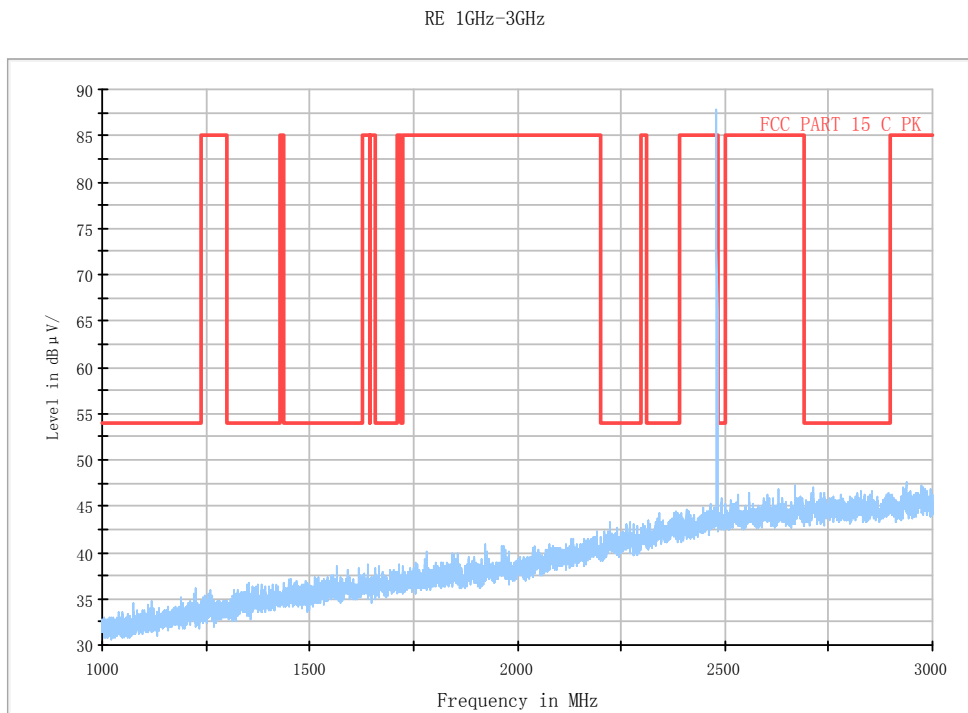

Fig.25 Radiated emission: Ch39, 1GHz-3GHz

RE 3GHz-18GHz

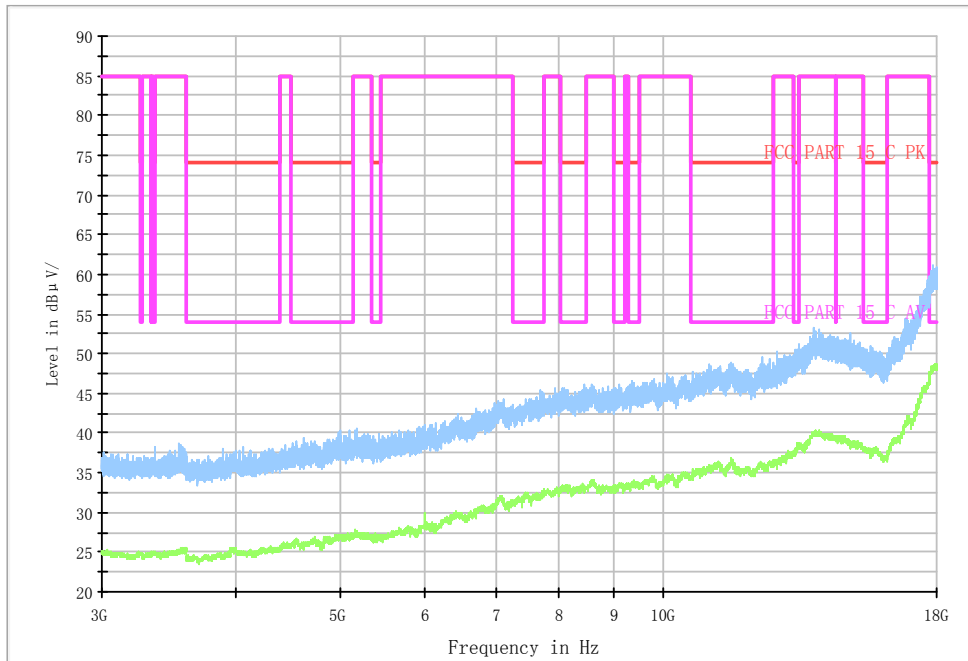

Fig.26 Radiated emission: Ch39, 3GHz-18GHz

Copy (2) of FCC Part15C 18-26G

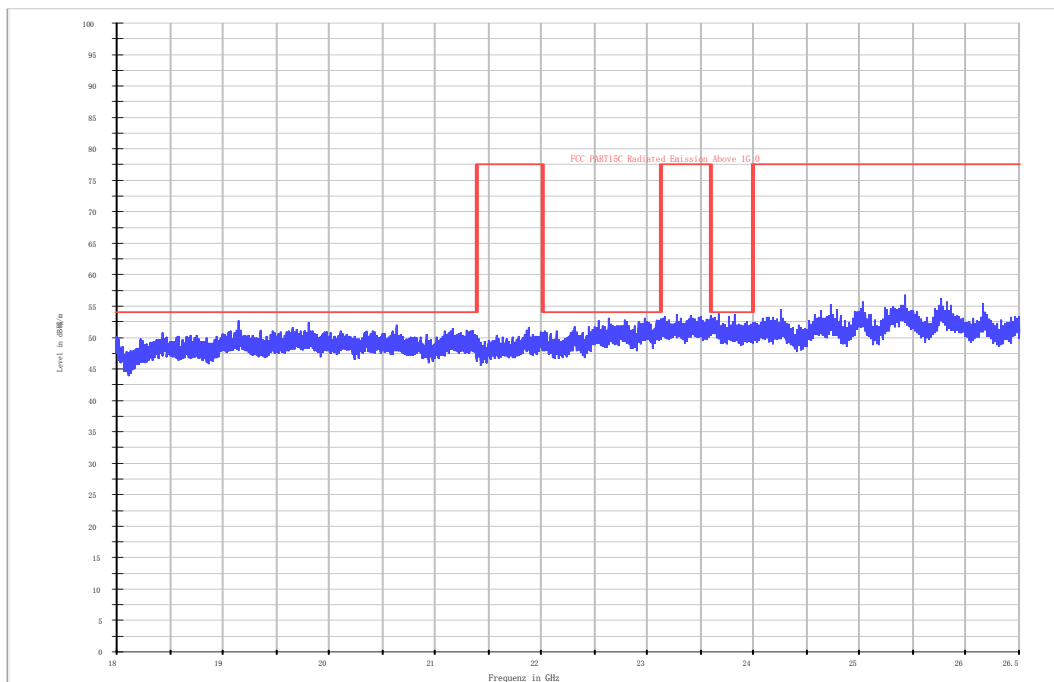

Fig.27 Radiated emission: 18 GHz - 26 GHz

Test photo

See the Pic1- Pic 6 in document "Ilium Pad T7X_Wifi_BT Test Setup Photos_Rev1".

5.7 Power line Conducted Emissions

Specifications:	ANSI C63.4 voltage mains test
DUT Serial Number:	S8/10: 358066070000665
Test conditions:	Ambient Temperature:15°C-35°C Relative Humidity:30%-60% Air pressure: 86-106kPa
Test Results:	--

Limit

The EUT meets the requirement of having a peak to average ratio of less than 13dB. For an intentional radiator which is designed to be connected to the public utility (AC) power line, the radio frequency voltage that is conducted back onto the AC power line on any frequency or frequencies within the band 150 kHz to 30 MHz shall not exceed 250 microvolt (The limit decreases linearly with the logarithm of the frequency in the range 0.15 MHz to 0.50 MHz). The limits at specific frequency range are listed as follows:

Limits of the conducted disturbance at the AC mains ports:

Frequency range	Limit(Quasi-peak)	Limit(Average)
0.15 MHz to 0.5 MHz	66 dBμV – 56 dBμV	56 dBμV – 46 dBμV
>0.5 MHz to 5MHz	56 dBμV	46 dBμV
>5 MHz to 30 MHz	60 dBμV	50 dBμV

NOTE: The limit decreases linearly with the logarithm of the frequency in the range 0.15 MHz to 0.50 MHz.

Compliance with this provision shall be based on the measurement of the radio frequency voltage between each power line (LINE and NEUTRAL) and ground at the power terminals.

Test Setup

The EUT was placed in a shielding room. The WLAN TESTER was used to set the TX channel and power level. The ac adapter output is connected to Receiver through an AMN (Artificial Mains Network).

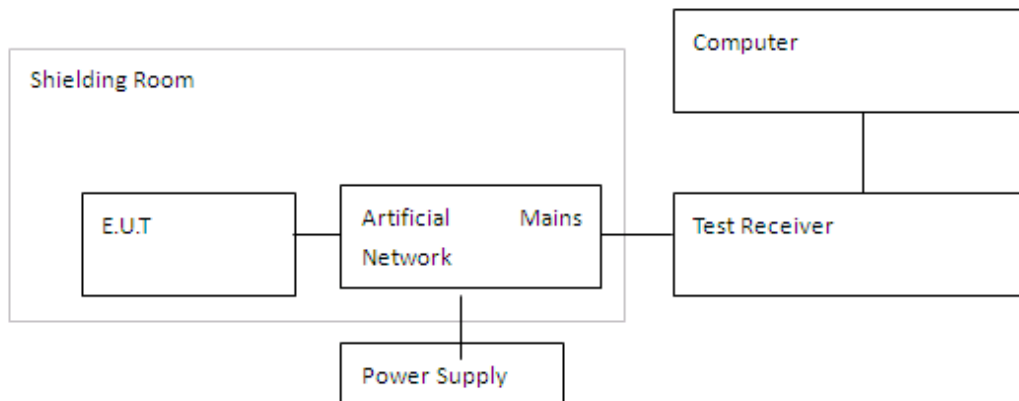

Test Procedure

1. The EUT is placed on a wooden table 80 cm above the reference ground plane.
2. The EUT is connected via LISN to a test power supply.
3. The measurement results are obtained as described below:
4. Detectors – Quasi Peak and Average Detector.

The measurement is made according to Public notice FCC Public Notice DA 00-705, March 2000, and ANSI C63.4-2014.

Test Result:

Line L&N					
Detector (QP)	Frequency (MHz)	Level (dBµV)	Limit (dBµV)	Line	PE
QP	0.456081	51.5	56.8	L1	FLO
QP	0.467781	42.5	56.6	L1	FLO
QP	0.567481	25.3	56.0	L1	FLO
QP	0.911831	41.3	56.0	L1	FLO
QP	0.912131	40.5	56.0	L1	FLO
QP	1.322300	41.9	56.0	L1	FLO

Line L&N					
Detector (AV)	Frequency (MHz)	Level (dBµV)	Limit (dBµV)	Line	PE
AV	0.451781	37.1	46.8	L1	FLO
AV	0.452081	37.6	46.8	L1	FLO
AV	1.314331	33.2	46.0	L1	FLO
AV	1.370300	18.3	46.0	L1	FLO
AV	2.881156	26.5	46.0	L1	FLO
AV	3.227356	25.0	46.0	N	FLO

Conclusion: PASS

CISPR N&L1 Voltage 150k to 30MHz-Class B

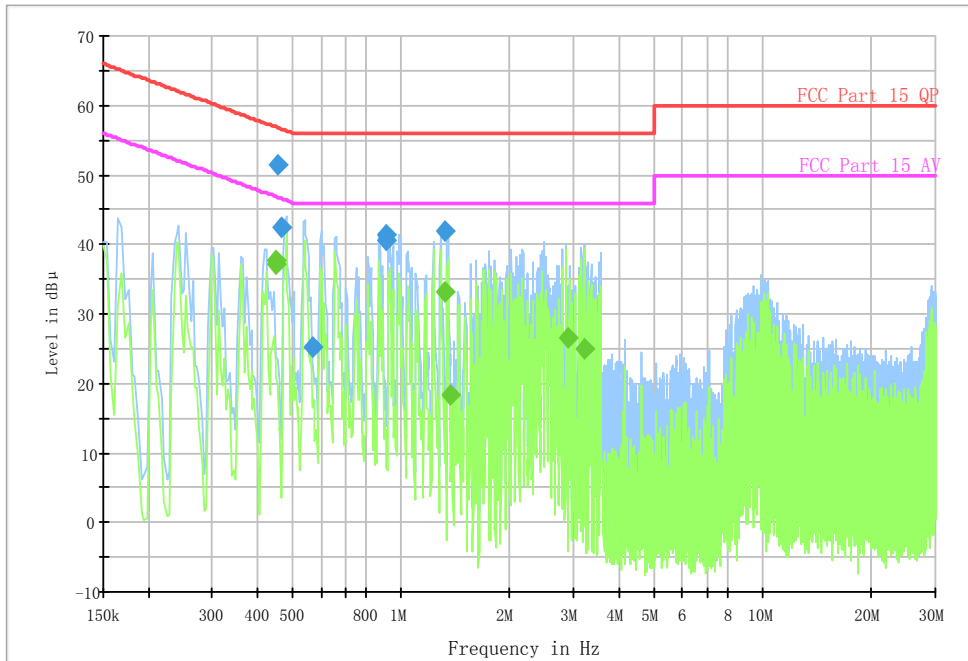

Line L & Line N

Test photo

See the Pic7 in document "Ilium Pad T7X_Wifi_BT_Test Setup Photos_Rev1".

Annex A EUT Photos

See the document "Ilium Pad T7X-External Photos".

See the document "Ilium Pad T7X-Internal Photos".

CITL Test Report

ANNEX B Deviations from Prescribed Test Methods

No deviation from Prescribed Test Methods.

*****End Of Report*****

ATTN Test Report