



FCC REPORT (Mobile phone)

Applicant: Corporativo Lanix S.A.de C.V.
Address of Applicant: Carrtera internacional Hermosillo-Nogale Km 8.5
Equipment Under Test (EUT)
Product Name: GSM Dual Band GPRS Digital Mobile Phone
Model No.: T60
Trade mark: LANIX
FCC ID: ZC4T60
Applicable standards: FCC CFR Title 47 Part 2 2010
FCC CFR Title 47 Part22H 2010
FCC CFR Title 47 Part24E 2010
Date of sample receipt: 22 Apr., 2011
Date of Test: 25-27 Apr., 2011
Date of report issued: 28 Apr., 2011
Test Result : PASS *

* In the configuration tested, the EUT complied with the standards specified above.

Authorized Signature:

Robinson Lo
Laboratory Manager

This report details the results of the testing carried out on one sample. The results contained in this test report do not relate to other samples of the same product and does not permit the use of the GTS product certification mark. The manufacturer should ensure that all products in series production are in conformity with the product sample detailed in this report.

This report may only be reproduced and distributed in full. If the product in this report is used in any configuration other than that detailed in the report, the manufacturer must ensure the new system complies with all relevant standards. Any mention of GTS International Electrical Approvals or testing done by GTS International Electrical Approvals in connection with, distribution or use of the product described in this report must be approved by GTS International Electrical Approvals in writing.

This document cannot be reproduced except in full, without prior written approval of the Company. Any unauthorized alteration, forgery or falsification of the content or appearance of this document is unlawful and offenders may be prosecuted to the fullest extent of the law. Unless otherwise stated the results shown in this test report refer only to the sample(s) tested and such sample(s) are retained for 90 days only."

2 Version

Version No.	Date	Description
<i>00</i>	<i>2011-04-28</i>	<i>Original</i>

Prepared By: Collin.He **Date:** 2011-04-28
Project Engineer

Check By: Hans.Hu **Date:** 2011-04-28
Reviewer

3 Contents

	Page
1 COVER PAGE	1
2 VERSION	2
3 CONTENTS	3
4 TEST SUMMARY	5
5 GENERAL INFORMATION	6
5.1 CLIENT INFORMATION	6
5.2 GENERAL DESCRIPTION OF E.U.T.....	6
5.3 RELATED SUBMITTAL(S) / GRANT (S)	6
5.4 TEST METHODOLOGY	6
5.5 TEST FACILITY.....	7
5.6 TEST LOCATION.....	7
5.7 TEST INSTRUMENTS LIST.....	8
6 SYSTEM TEST CONFIGURATION	9
6.1 EUT CONFIGURATION	9
6.2 EUT EXERCISE	9
6.3 TEST PROCEDURE	9
6.3.1 Conducted Emissions.....	9
6.3.2 Radiated Emissions.....	9
6.4 CONFIGURATION OF TESTED SYSTEM	9
6.5 DESCRIPTION OF TEST MODES.....	10
7 RF POWER OUTPUT MEASUREMENT	11
7.1 STANDARD APPLICABLE	11
7.2 TEST SETUP	11
7.3 MEASUREMENT PROCEDURE	11
7.4 TEST RESULT	11
8 ERP, EIRP MEASUREMENT	13
8.1 STANDARD APPLICABLE	13
8.2 TEST SET-UP (BLOCK DIAGRAM OF CONFIGURATION).....	13
8.3 MEASUREMENT PROCEDURE	14
8.4 MEASUREMENT RESULT	15
9 MODULATION CHARACTERISTIC	17
10 OCCUPIED BANDWIDTH	18
10.1 STANDARD APPLICABLE	18
10.2 TEST SETUP.....	18
10.3 TEST PROCEDURE	18
10.4 TEST RESULT	18
11 OUT OF BAND EMISSION AT ANTENNA TERMINALS	22
11.1 STANDARD APPLICABLE	22
11.2 TEST SETUP.....	22

11.3	MEASUREMENT PROCEDURE	22
11.4	MEASUREMENT RESULT	22
11.4.1	<i>Spurious emission</i>	23
11.4.2	<i>Band edge emission</i>	27
12	FIELD STRENGTH OF SPURIOUS RADIATION MEASUREMENT	29
12.1	STANDARD APPLICABLE	29
12.2	EUT SETUP (BLOCK DIAGRAM OF CONFIGURATION)	29
12.3	MEASUREMENT PROCEDURE	30
12.4	TEST RESULT	31
13	FREQUENCY STABILITY V.S. TEMPERATURE MEASUREMENT	37
13.1	STANDARD APPLICABLE	37
13.2	TEST SETUP	37
13.3	TEST PROCEDURE	37
13.4	TEST RESULT	38
14	FREQUENCY STABILITY V.S. VOLTAGE MEASUREMENT	39
14.1	STANDARD APPLICABLE	39
14.2	TEST SETUP	39
14.3	TEST PROCEDURE	39
14.4	TEST RESULT	40
15	AC POWER LINE CONDUCTED EMISSION TEST	41
15.1	STANDARD APPLICABLE	41
15.2	TEST SETUP	41
15.3	TEST PROCEDURE	41
15.4	MEASUREMENT RESULT	41
16	TEST SETUP PHOTO	46
17	EUT CONSTRUCTIONAL DETAILS	47

4 Test Summary

Test Item	Section in CFR 47	Result
RF Exposure (SAR)	§1.1307, §2.1093	Passed* (Please refer to SAR Report)
RF Output Power	§2.1046; § 22.913 (a) § 24.232 (c)	PASS
Modulation Characteristics	§ 2.1047	PASS
99% & -26 dB Occupied Bandwidth	§ 2.1049 § 22.905 § 22.917 § 24.238	PASS
Spurious Emissions at Antenna Terminal	§ 2.1051, § 22.917 (a) § 24.238 (a)	PASS
Field Strength of Spurious Radiation	§ 2.1053 § 22.917 (a) § 24.238 (a)	PASS
Out of band emission, Band Edge	§ 22.917 (a) § 24.238 (a)	PASS
Frequency stability vs. temperature Frequency stability vs. voltage	§ 2.1055 § 22.355 § 24.235	PASS

5 General Information

5.1 Client Information

Applicant:	Corporativo Lanix S.A.de C.V.
Address of Applicant:	Carrera internacional Hermosillo-Nogale Km 8.5
Manufacturer/Factory:	SHENZHEN KONKA TELECOMMUNICATION TECHNOLOGY CO.,LTD
Address of Manufacturer/Factory :	No.9008 Shennan Road,Overseas Chinese Town, ShenZhen, Guangdong,China

5.2 General Description of E.U.T.

Product Name:	GSM Dual Band GPRS Digital Mobile Phone
Model No.:	T60
Data cable(USB):	Length 1m
Earphone line:	Length 1.5m
Power supply:	DC 3.7V Li-ion rechargeable Battery
AC adapter:	Input: AC 100-240V 50/60Hz 0.15A Max Output: DC 5V 500mA

Cellular Phone Standards Frequency Range and Power	GSM/GPRS 850	824MHz-849MHz	31.69dBm
	PCS1900	1850MHz-1910MHz	28.30dBm
Type of Emission:	248KGXW		
IMEI:	866608000000029		
Software Version:	KAAT518_MXB_En_1.00.C28		
Hardware Version:	V1.2		

5.3 Related Submittal(s) / Grant (s)

This submittal(s) (test report) is filing to comply with Section Part 22 subpart H and Part 24 subpart E of the FCC CFR 47 Rules.

5.4 Test Methodology

Both conducted and radiated testing were performed according to the procedures document on chapter 13 of ANSI C63.4 (2003) and FCC CFR 47.1046, 2.1047, 2.1049, 2.1051, 2.1053, 2.1055 and 2.1057

5.5 Test Facility

The test facility is recognized, certified, or accredited by the following organizations:

- FCC —Registration No.: 600491

Global United Technology Services Co., Ltd., Shenzhen EMC Laboratory has been registered and fully described in a report filed with the (FCC) Federal Communications Commission. The acceptance letter from the FCC is maintained in files. Registration 600491, July 20, 2010.

- Industry Canada (IC)

The 3m Semi-anechoic chamber of Global United Technology Services Co., Ltd. has been Registered by Certification and Engineering Bureau of Industry Canada for radio equipment testing with Registration No.: 9079A-1.

5.6 Test Location

All tests were performed at:

Global United Technology Services Co., Ltd.

Address: 2nd Floor, Block No.2, Laodong Industrial Zone, Xixiang Road Baoan District, Shenzhen, China

Tel: 0755-27798480

Fax: 0755-27798960

5.7 Test Instruments list

Radiated Emission:						
Item	Test Equipment	Manufacturer	Model No.	Inventory No.	Cal.Date (dd-mm-yy)	Cal.Due date (dd-mm-yy)
1	3m Semi-Anechoic Chamber	ZhongYu Electron	9.2(L)*6.2(W)* 6.4(H)	GTS201	Mar. 30 2011	Mar. 30 2012
2	Control Room	ZhongYu Electron	6.2(L)*2.5(W)* 2.4(H)	GTS202	N/A	N/A
3	EMI Test Receiver	Rohde & Schwarz	ESU26	GTS203	Sept. 10 2010	Sept. 10 2011
4	BiConiLog Antenna	SCHWARZBECK MESS-ELEKTRONIK	VULB9163	GTS204	Feb. 26 2011	Feb. 26 2012
5	Double -ridged waveguide horn	SCHWARZBECK MESS-ELEKTRONIK	9120D-829	GTS205	June 30 2010	June 30 2011
6	EMI Test Software	AUDIX	E3	N/A	N/A	N/A
7	Coaxial Cable	GTS	N/A	GTS400	Apr. 01 2011	Apr. 01 2012
8	Coaxial Cable	GTS	N/A	GTS401	Apr. 01 2011	Apr. 01 2012
9	Coaxial cable	GTS	N/A	GTS402	Apr. 01 2011	Apr. 01 2012
10	Coaxial Cable	GTS	N/A	GTS407	Apr. 01 2011	Apr. 01 2012
11	Coaxial Cable	GTS	N/A	GTS408	Apr. 01 2011	Apr. 01 2012
12	Amplifier(10KHz-5GHz)	Sonnoma Instrument	305-1052	GTS210	Apr. 01 2011	Apr. 01 2012
13	Amplifier(2GHz-20GHz)	HP	8349B	GTS231	Apr. 01 2011	Apr. 01 2012
14	Universal radio communication tester	Rohde & Schwarz	CMU200	GTS235	May 11 2010	May 11 2011
15	Signal Generator	Rohde & Schwarz	SML03	GTS236	May 11 2010	May 11 2011
16	Temp. Humidity/Barometer	Oregon Scientific	BA-888	GTS248	May 11 2010	May 11 2011
17	D.C. Power Supply	Instek	PS-3030	GTS232	NA	NA
18	Splitter	Agilent	11636B	GTS237	May 11 2010	May 11 2011

Conducted Emission:						
Item	Test Equipment	Manufacturer	Model No.	Inventory No.	Cal.Date (dd-mm-yy)	Cal.Due date (dd-mm-yy)
1	Shielding Room	ZhongYu Electron	7.0(L)x3.0(W)x3.0(H)	GTS206	Apr. 10 2011	Apr. 10 2012
2	EMI Test Receiver	Rohde & Schwarz	ESCS30	GTS208	Sept. 14 2010	Sept. 14 2011
3	10dB Pulse Limita	Rohde & Schwarz	N/A	GTS209	Sept. 14 2010	Sept. 14 2011
4	LISN	SCHWARZBECK MESS-ELEKTRONIK	NSLK 8127	GTS207	Apr. 14 2011	Apr. 14 2012
5	Coaxial Cable	GTS	N/A	GTS406	Apr. 01 2011	Apr. 01 2012
6	EMI Test Software	AUDIX	E3	N/A	N/A	N/A

6 SYSTEM TEST CONFIGURATION

6.1 EUT Configuration

The EUT configuration for testing is installed on RF field strength measurement to meet the Commissions requirement and operating in a manner which intends to maximize its emission characteristics in a continuous normal application.

6.2 EUT Exercise

The EUT (Transmitter) was operated in the engineering mode to fix the Tx frequency which was for the purpose of the measurements.

6.3 Test Procedure

6.3.1 Conducted Emissions

The EUT is placed on a turn table which is 0.8m above ground plane. According to the requirements in Section 7 and 13 of ANSI C63.4-2003. Conducted emissions from the EUT measured in the frequency range between 0.15MHz and 30MHz using CISPR Quasi-Peak and Average detector mode.

6.3.2 Radiated Emissions

The EUT is placed on a turn table which is 1.0m above ground plane. The turn table shall rotate 360 degrees to determine the position of maximum emission level. EUT is set 3m away from the receiving antenna which varied from 1m to 4m to find out the highest emission. And also, each emission was to be maximized by changing the polarization of receiving antenna both horizontal and vertical. In order to find out the max. emission, the relative positions of this hand-held transmitter (EUT) was rotated through three orthogonal axes according to the requirements in Section 8 and 13 of ANSI C63.4-2003.

6.4 Configuration of Tested System

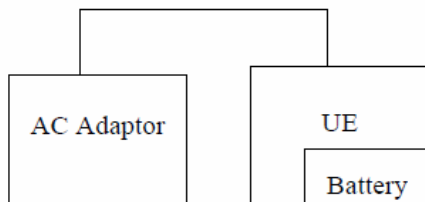

Remote Side

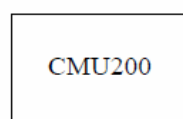

6.5 DESCRIPTION OF TEST MODES

The EUT has been tested under operating condition.

EUT staying in continuous transmitting mode. Channel Low, Mid and High for each type band with rated data rate were chosen for full testing.

The field strength of spurious radiation emission was measured as EUT stand-up position (H mode) and lie down position (E1, E2 mode) for both GSM/PCS with power adaptors, earphone and Data cable. The worst-case H mode for GSM 850 band, PCS1900 band.

7 RF POWER OUTPUT MEASUREMENT

7.1 Standard Applicable

According to FCC §2.1046.

FCC 22.913(a) Mobile station are limited to 7W

FCC 24.232(b) Mobile station are limited to 2W.

7.2 Test setup

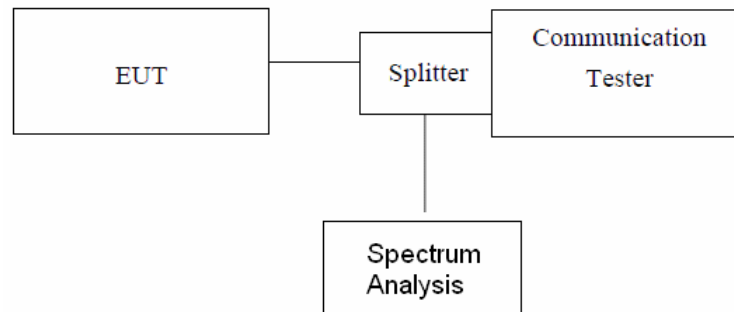

Note: Measurement setup for testing on Antenna connector

7.3 Measurement Procedure

The transmitter output was connected to a calibrated attenuator, the other end of which was connected to a spectrum analysis. Transmitter output was read off the spectrum analysis in dBm. The power output at the transmitter antenna port was determined by adding the value of the attenuator to spectrum analysis reading.

7.4 Test Result

EUT Mode	Frequency (MHz)	Channel	PK power (dBm)
GSM 850	824.20	128	31.55
	836.60	190	31.35
	848.80	251	31.69

EUT Mode	Frequency (MHz)	Channel	PK power (dBm)
PCS 1900	1850.20	512	27.76
	1880.00	661	28.30
	1909.80	810	28.21

Please refer to the following plots.

Test mode: GSM850

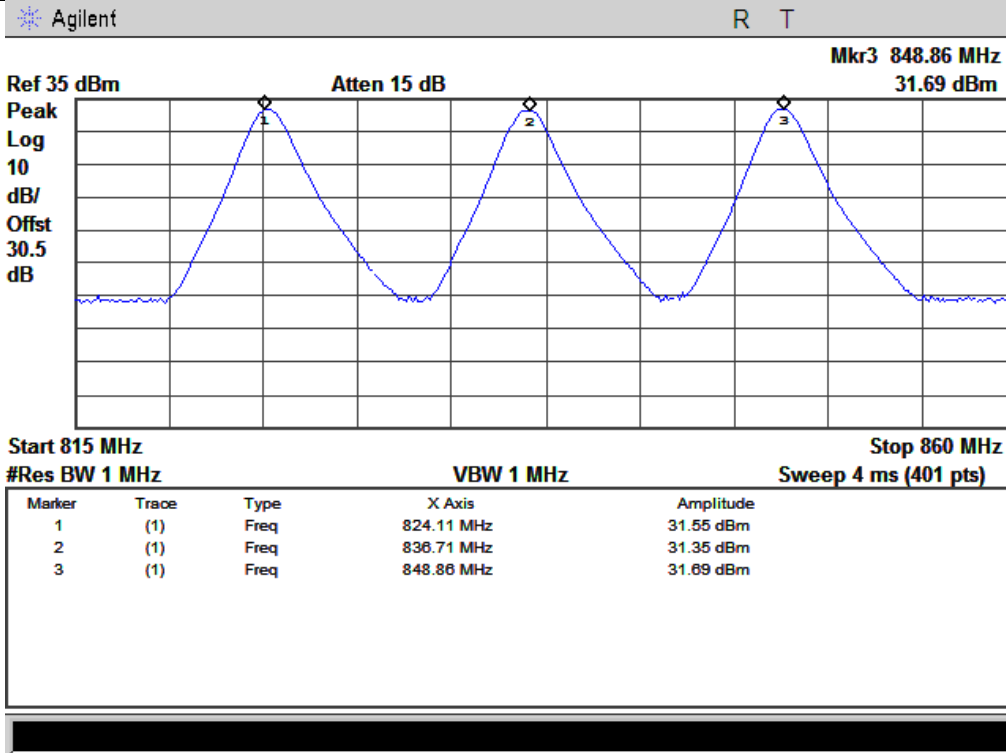

Test mode: PCS1900

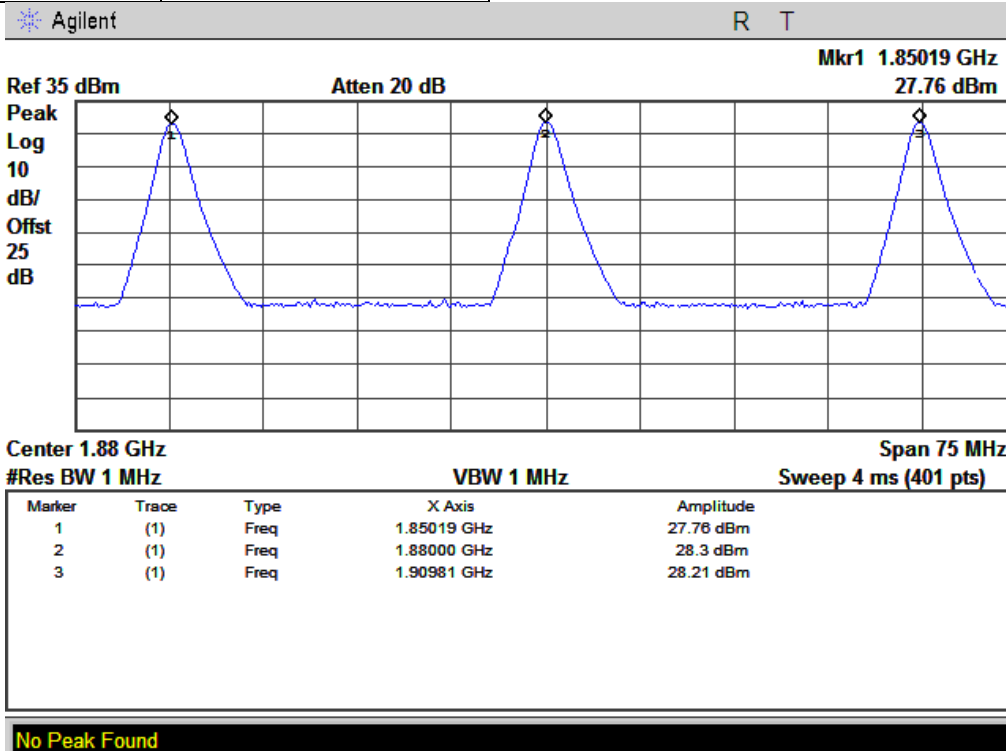

8 ERP, EIRP MEASUREMENT

8.1 Standard Applicable

According to FCC §2.1046

FCC 22.913(a) Mobile station are limited to 7W ERP.

FCC 24.232(b) Mobile station are limited to 2W EIRP.

8.2 Test SET-UP (Block Diagram of Configuration)

(A) Radiated Emission Test Set-Up, Frequency Below 1000MHz

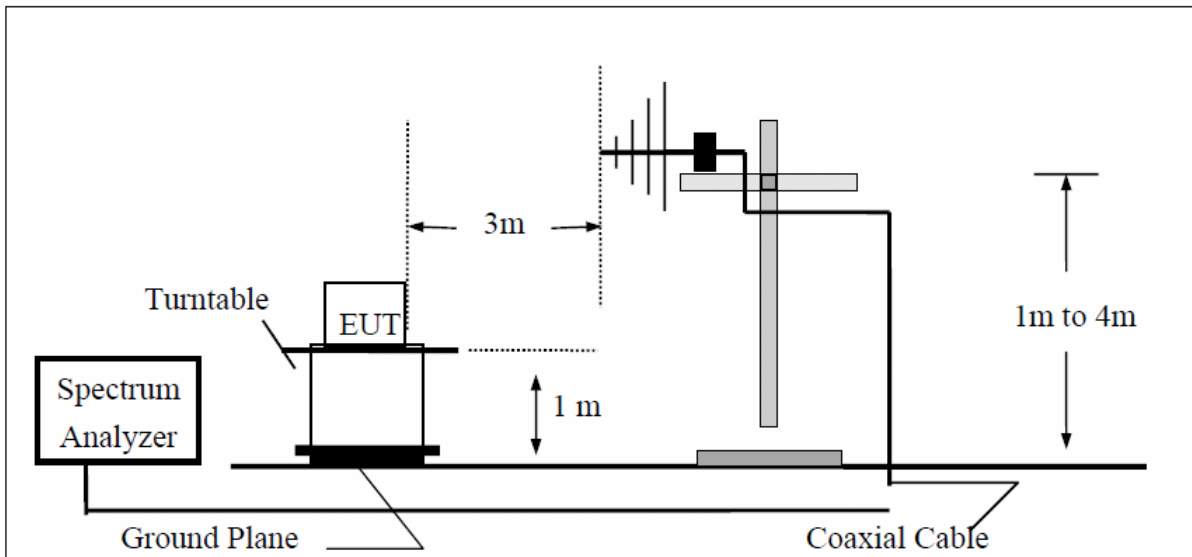

(B) Radiated Emission Test Set-UP Frequency Over 1 GHz

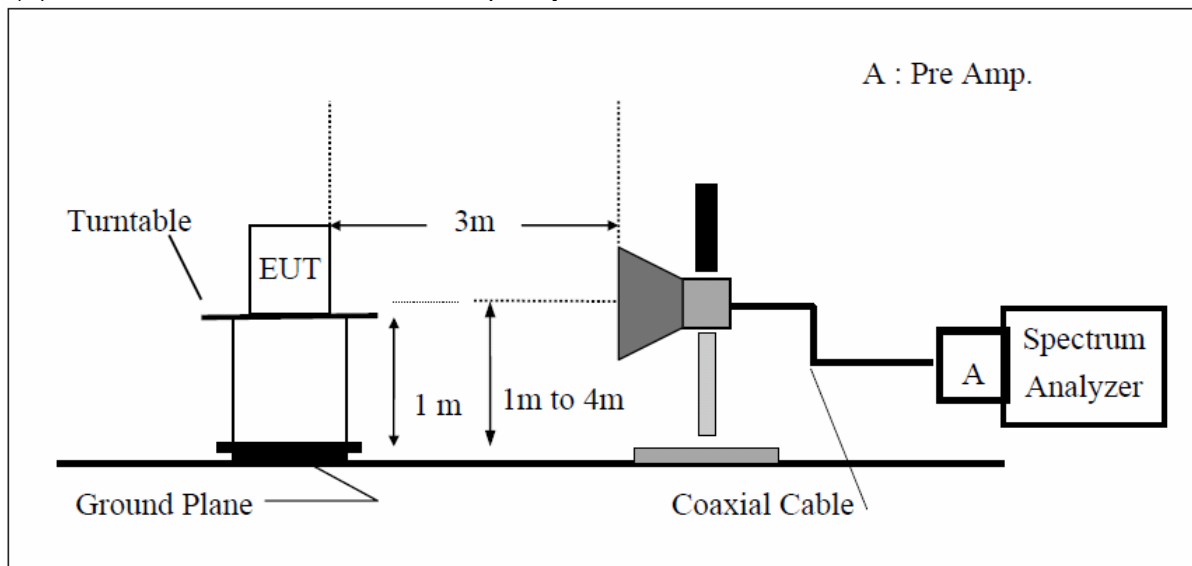

(C) Substituted Method Test Set-UP

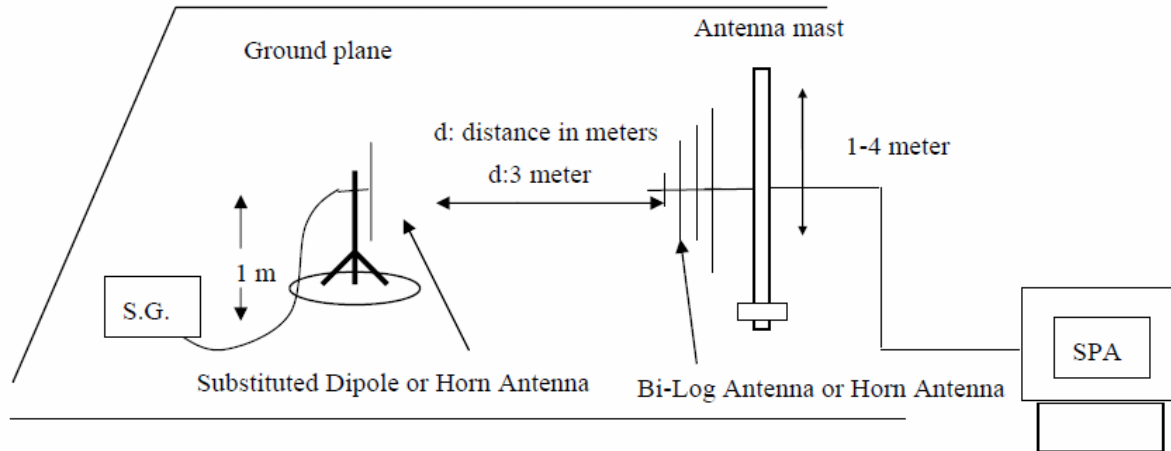

8.3 Measurement Procedure

The EUT was placed on an non-conductive turntable using a non-conductive support. The radiated emission at the fundamental frequency was measured at 3 m with a test antenna and EMI spectrum analyzer.

During the measurement, the EUT was communication with the station. The highest emission was recorded with the rotation of the turntable and the lowering of the test antenna from 4m to 1m. The reading was recorded and the field strength (E in dBuV/m) was calculated.

ERP in frequency band 824.2 –848.80.8MHz were measured using a substitution method. The EUT was replaced by dipole antenna connected, the S.G. output was recorded and ERP was calculated as follows:

EIRP in frequency band 1850.2 –1909.8MHz were measured using a substitution method. The EUT was replaced by or horn antenna connected, the S.G. output was recorded and EIRP was calculated as follows:

$$\text{ERP} = \text{S.G. output (dBm)} + \text{Antenna Gain (dBd)} - \text{Cable Loss (dB)}$$

$$\text{EIRP} = \text{S.G. output (dBm)} + \text{Antenna Gain (dBi)} - \text{Cable Loss (dB)}$$

8.4 Measurement Result

EUT mode	Frequency (MHz)	CH	EUT Pol.	Antenna Pol.	SPA Reading (dBuV)	S.G. Output (dBm)	Antenna Gain (dBd)	Cable Loss (dB)	ERP (dBm)	Limit (dBm)
GSM 850	824.20	128	H	V	118.53	32.14	-7.87	3.62	20.65	38.45
				H	125.31	42.04	-7.87	3.62	30.55	38.45
			E1	V	121.26	34.87	-7.87	3.62	23.38	38.45
				H	114.73	29.46	-7.87	3.62	17.97	38.45
			E2	V	115.80	29.41	-7.87	3.62	17.92	38.45
				H	123.72	37.45	-7.87	3.62	25.96	38.45
	836.60	190	H	V	119.50	33.25	-7.88	3.65	21.72	38.45
				H	127.01	41.90	-7.88	3.65	30.37	38.45
			E1	V	122.62	36.37	-7.88	3.65	24.84	38.45
				H	115.78	29.55	-7.88	3.65	18.02	38.45
			E2	V	116.69	30.44	-7.88	3.65	18.91	38.45
				H	125.59	39.36	-7.88	3.65	27.83	38.45
	848.80	251	H	V	121.28	35.16	-7.88	3.68	23.60	38.45
				H	128.85	41.62	-7.88	3.68	30.06	38.45
			E1	V	124.85	38.73	-7.88	3.68	27.17	38.45
				H	116.88	30.69	-7.88	3.68	19.13	38.45
			E2	V	118.09	31.97	-7.88	3.68	20.41	38.45
				H	125.73	39.49	-7.88	3.68	27.93	38.45

Remark :

- (1) The RBW,VBW of SPA for frequency
 Below 1GHz was RBW=100 KHz, VBW=300KHz,
 Above 1GHz was RBW= 1MHz , VBW= 3MHz

EUT mode	Frequency (MHz)	CH	EUT Pol.	Antenna Pol.	SPA Reading (dBuV)	S.G. Output (dBm)	Antenna Gain (dBd)	Cable Loss (dB)	ERP (dBm)	Limit (dBm)
PCS 1900	1850.20	512	H	V	122.80	18.41	9.90	5.56	22.75	33.00
				H	129.97	25.55	9.90	5.56	29.89	33.00
			E1	V	124.28	19.89	9.90	5.56	24.23	33.00
				H	127.40	23.22	9.90	5.56	27.56	33.00
			E2	V	125.94	21.55	9.90	5.56	25.89	33.00
				H	128.81	23.63	9.90	5.84	27.69	33.00
	1880.00	661	H	V	121.01	16.65	9.99	5.61	21.03	33.00
				H	129.71	25.57	9.99	5.61	29.95	33.00
			E1	V	126.79	22.43	9.99	5.61	26.81	33.00
				H	126.44	22.60	9.99	5.61	26.98	33.00
			E2	V	124.50	21.14	9.99	5.61	25.52	33.00
				H	130.08	23.94	9.99	5.61	28.32	33.00
	1909.80	810	H	V	121.23	16.90	10.08	5.66	21.32	33.00
				H	128.71	25.60	10.08	5.66	30.02	33.00
			E1	V	125.73	20.40	10.08	5.66	24.82	33.00
				H	125.92	21.81	10.08	5.66	26.23	33.00
			E2	V	125.00	20.67	10.08	5.66	25.09	33.00
				H	128.14	24.03	10.08	5.66	28.45	33.00

Remark :

- (1) The RBW,VBW of SPA for frequency
 Below 1GHz was RBW=100 KHz, VBW=300KHz,
 Above 1GHz was RBW= 1MHz , VBW= 3MHz

9 MODULATION CHARACTERISTIC

According to FCC § 2.1047(d), Part 22H & 24E there is no specific requirement for digital modulation, therefore modulation characteristic is not presented.

10 OCCUPIED BANDWIDTH

10.1 Standard Applicable

CFR 47 §2.1049

10.2 Test setup

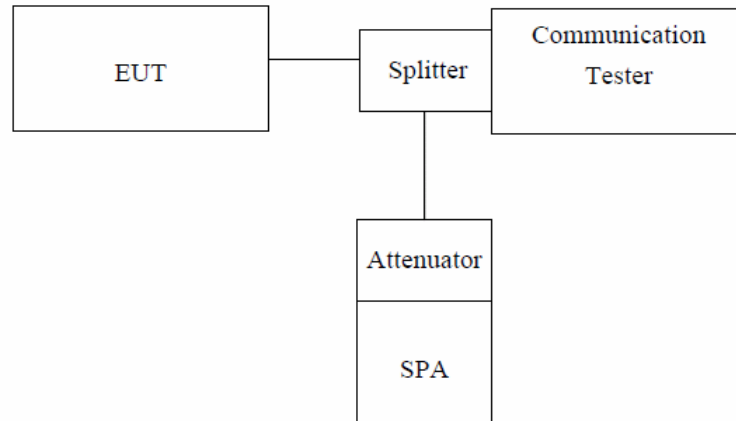

Note: Measurement setup for testing on Antenna connector

10.3 Test Procedure

The EUT's output RF connector was connected with a short cable to the spectrum analyzer, RBW (10/47KHz) was set to about 1% of emission BW, VBW= 3 times RBW(30/150KHz), -26dBc display line was placed on the screen (or 99% bandwidth), the occupied bandwidth is the delta frequency between the two points where the display line intersects the signal trace.

10.4 Test Result

EUT Mode	Frequency(MHz)	CH	26dB bandwidth	99% Bandwidth(MHz)
GSM 850	824.20	128	318.772	246.335
	836.60	190	315.741	245.240
	848.80	251	321.918	248.486

EUT Mode	Frequency(MHz)	CH	26dB bandwidth	99% Bandwidth(MHz)
PCS 1900	1850.20	512	311.985	243.838
	1880.00	661	311.732	244.791
	1909.80	810	310.021	246.383

Please refer to the following plots.

Test mode:	GSM850	Test channel:	128
------------	--------	---------------	-----

Agilent R T

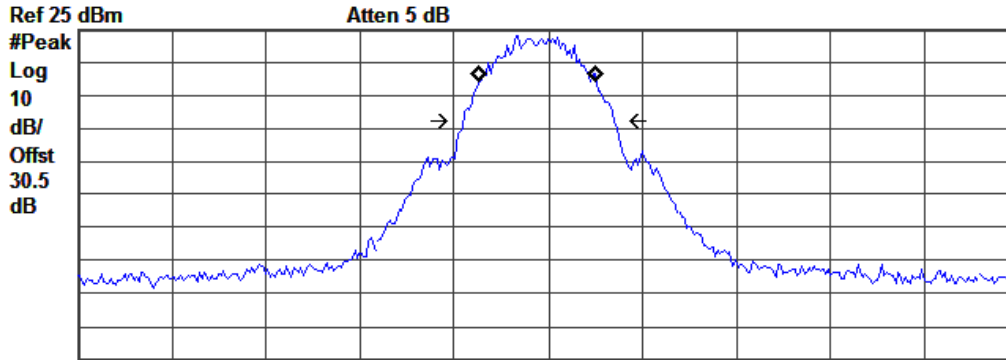

Center 824.2 MHz Span 2 MHz
 #Res BW 3 kHz #VBW 3 kHz Sweep 286.3 ms (401 pts)
Occupied Bandwidth 246.3353 kHz
 Occ BW % Pwr 99.00 %
 x dB -26.00 dB

Transmit Freq Error -21.156 kHz
 x dB Bandwidth 318.772 kHz

Test mode:	GSM850	Test channel:	190
------------	--------	---------------	-----

Agilent R T

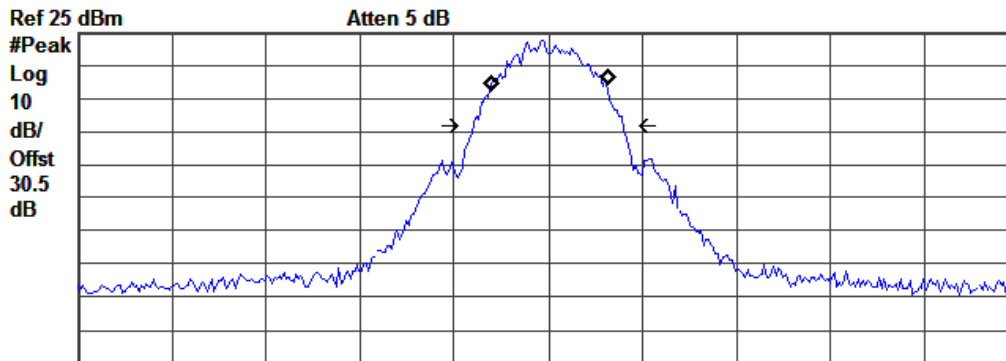

Center 836.6 MHz Span 2 MHz
 #Res BW 3 kHz #VBW 3 kHz Sweep 286.3 ms (401 pts)
Occupied Bandwidth 245.2408 kHz
 Occ BW % Pwr 99.00 %
 x dB -26.00 dB

Transmit Freq Error 157.317 Hz
 x dB Bandwidth 315.741 kHz

Test mode:	GSM850	Test channel:	251
------------	--------	---------------	-----

Agilent R T

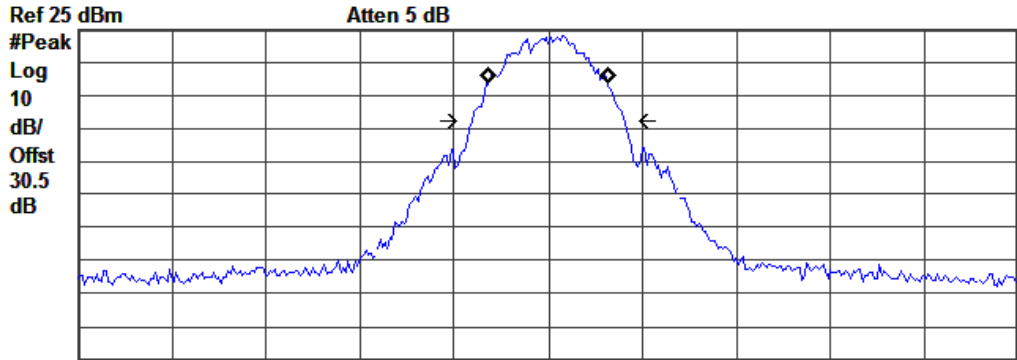

Center 848.8 MHz Span 2 MHz
 #Res BW 3 kHz #VBW 3 kHz Sweep 286.3 ms (401 pts)
Occupied Bandwidth Occ BW % Pwr 99.00 %
 248.4860 kHz x dB -26.00 dB

Transmit Freq Error -81.677 Hz
 x dB Bandwidth 321.918 kHz

Test mode:	PCS1900	Test channel:	512
------------	---------	---------------	-----

Agilent R T

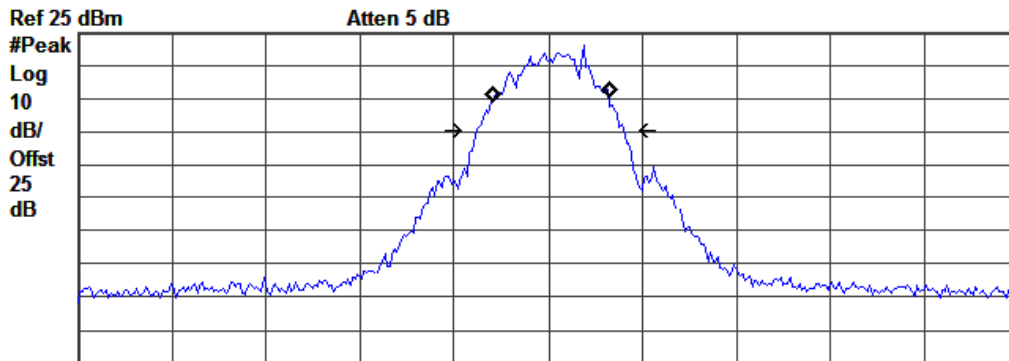

Center 1.85 GHz Span 2 MHz
 #Res BW 3 kHz #VBW 3 kHz Sweep 286.3 ms (401 pts)
Occupied Bandwidth Occ BW % Pwr 99.00 %
 243.8380 kHz x dB -26.00 dB

Transmit Freq Error 5.622 kHz
 x dB Bandwidth 311.985 kHz

Test mode:	PCS1900	Test channel:	661
------------	---------	---------------	-----

Agilent R T

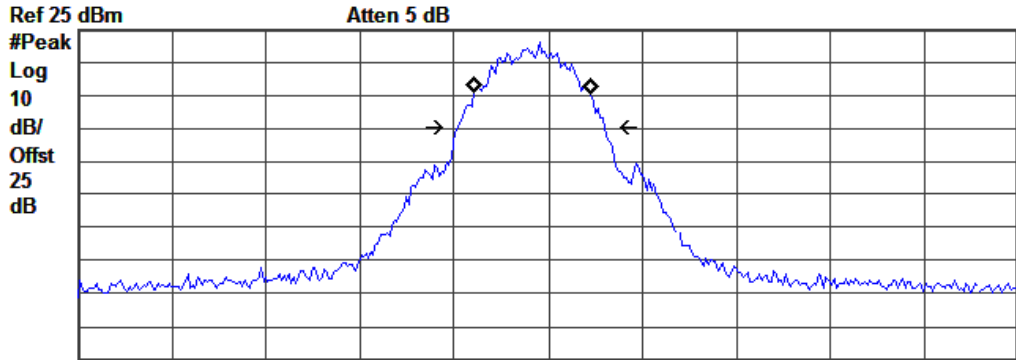

Center 1.88 GHz Span 2 MHz
 #Res BW 3 kHz #VBW 3 kHz Sweep 286.3 ms (401 pts)
Occupied Bandwidth Occ BW % Pwr 99.00 %
 244.7910 kHz x dB -26.00 dB

Transmit Freq Error -33.451 kHz
 x dB Bandwidth 311.732 kHz

Test mode:	PCS1900	Test channel:	810
------------	---------	---------------	-----

Agilent R T

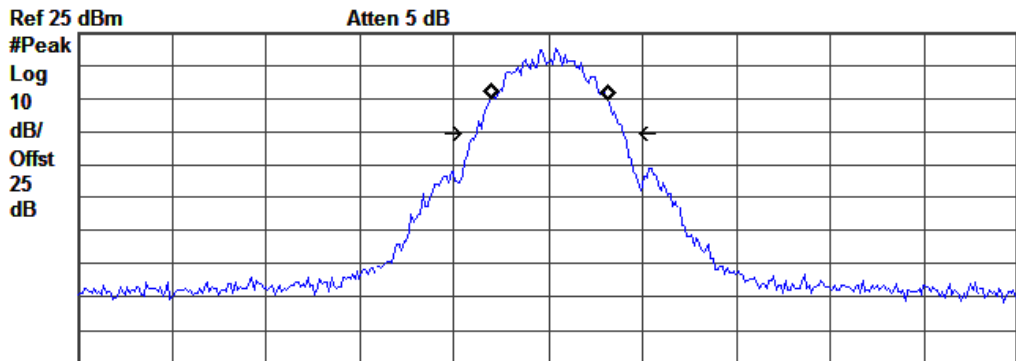

Center 1.91 GHz Span 2 MHz
 #Res BW 3 kHz #VBW 3 kHz Sweep 286.3 ms (401 pts)
Occupied Bandwidth Occ BW % Pwr 99.00 %
 246.3830 kHz x dB -26.00 dB

Transmit Freq Error 2.649 kHz
 x dB Bandwidth 310.021 kHz

11 OUT OF BAND EMISSION AT ANTENNA TERMINALS

11.1 Standard Applicable

According to FCC §2.1051.

FCC §22.917(a), §24.238(a), the magnitude of each spurious and harmonic emission that can be detected when the equipment is operated under the conditions specified in the instruction manual and/ or alignment procedure, shall not be less than $43 + 10 \log$ (mean output power in watts) dBc below the mean power output outside a license's frequency block (-13dBm)

11.2 Test setup

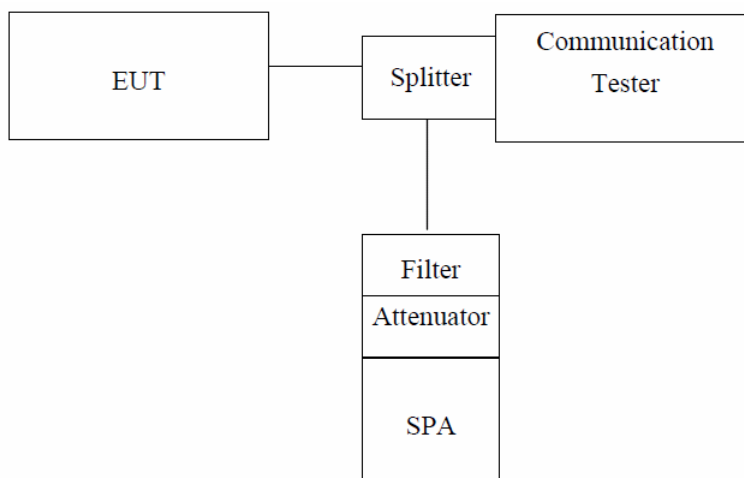

Note: Measurement setup for testing on Antenna connector

11.3 Measurement Procedure

The RF output of the transceiver was connected to a spectrum analyzer through appropriate attenuation. The resolution bandwidth of the spectrum analyzer was set at 1MHz, sufficient scans were taken to show the out of band Emissions if any up to 10th harmonic.

For the out of band: Set the RBW, VBW = 1MHz, Start=30MHz, Stop= 10th harmonic.

Limit = -13dBm

Band Edge Requirements: In the 1 MHz bands immediately outside and adjacent to the frequency block, a resolution bandwidth of at least 1 percent of the emission bandwidth of the fundamental emission of the transmitter may be employed to measure the out of band Emissions.

Limit = -13dBm.

11.4 Measurement Result

11.4.1 Spurious emission

Test mode:	GSM850	Test channel:	128
------------	--------	---------------	-----

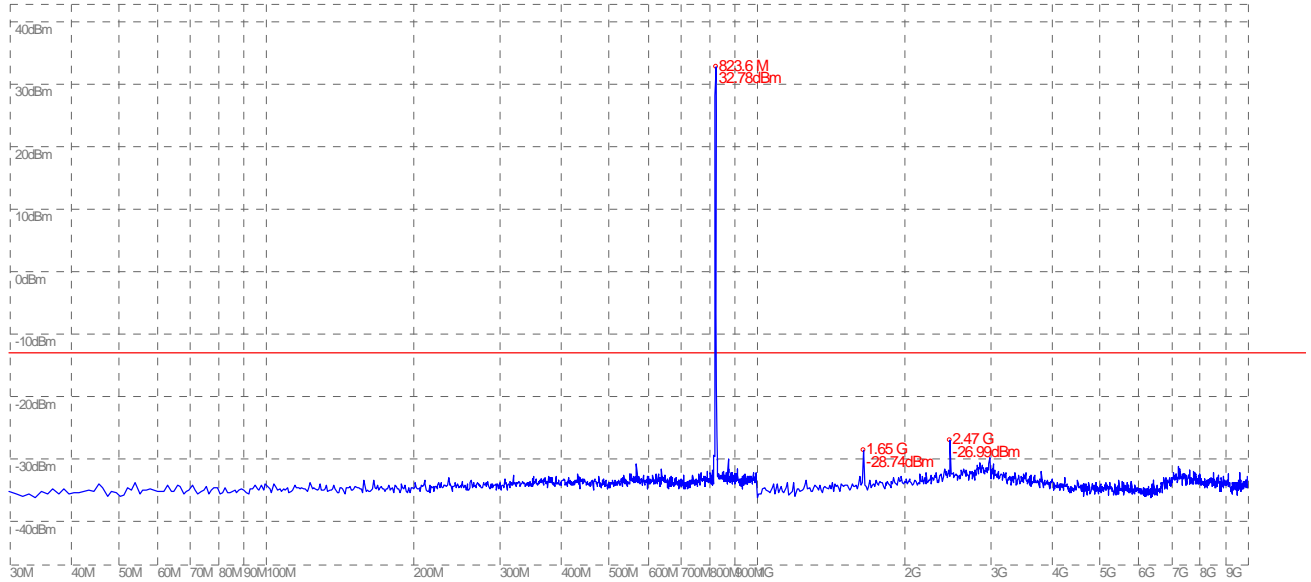

Test mode:	GSM850	Test channel:	190
------------	--------	---------------	-----



Test mode:	GSM850	Test channel:	251
------------	--------	---------------	-----

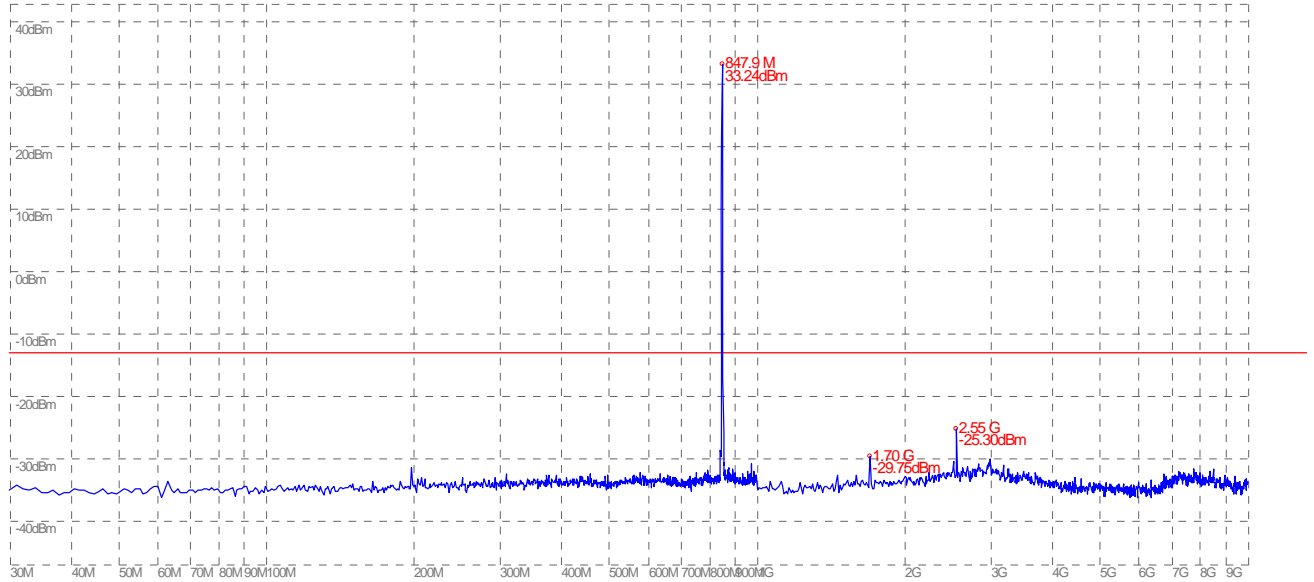

Test mode:	PCS1900	Test channel:	512
------------	---------	---------------	-----

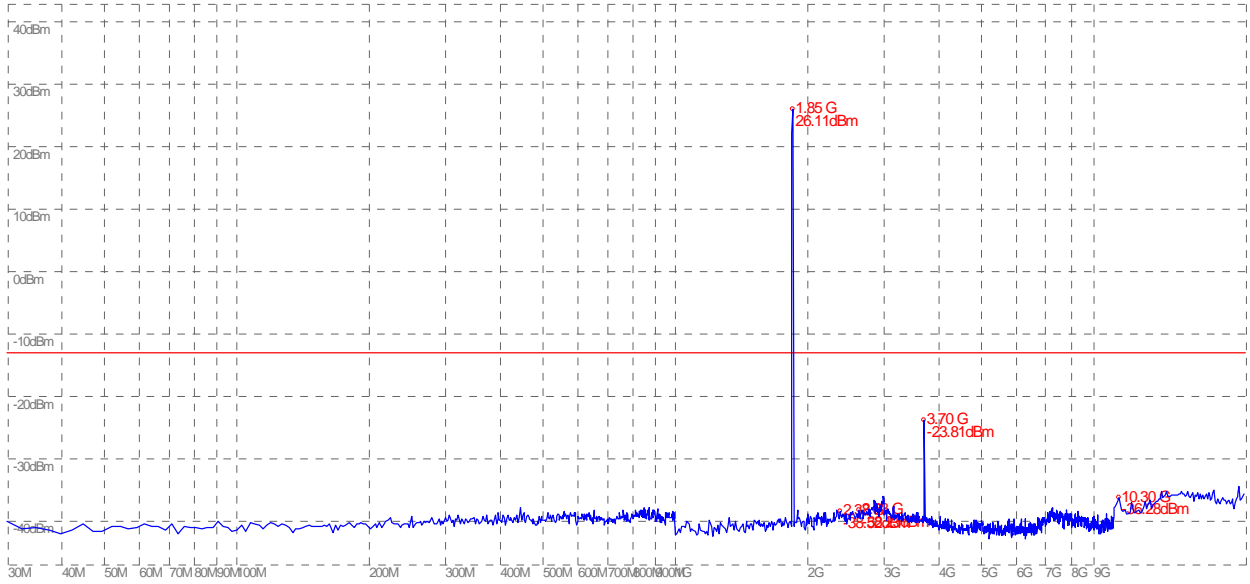

Test mode:	PCS1900	Test channel:	661
------------	---------	---------------	-----

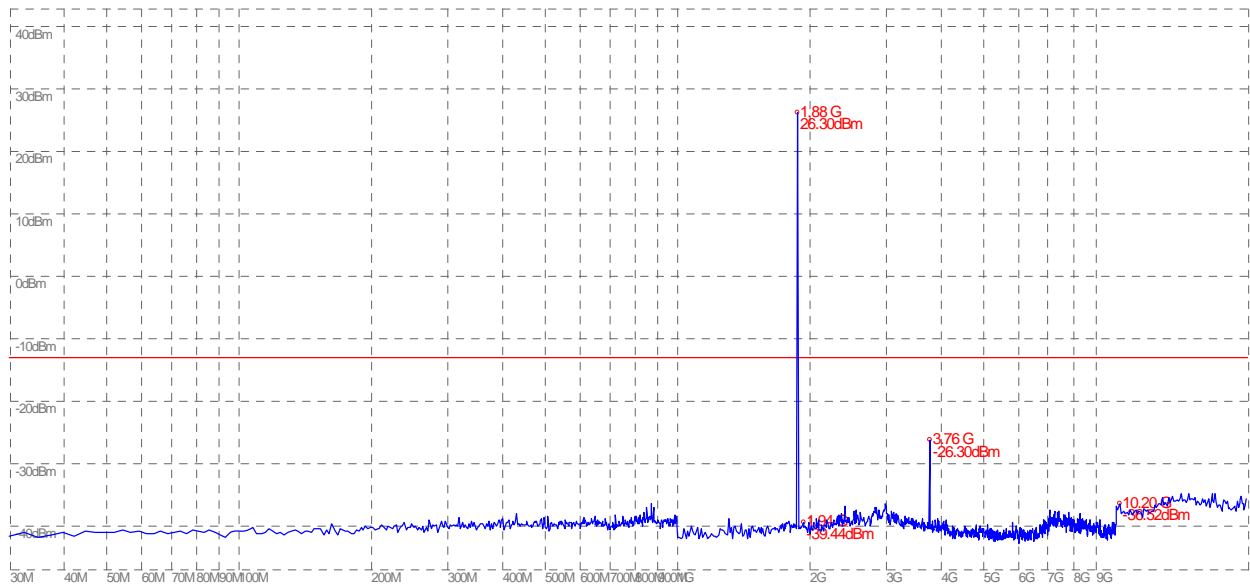

Test mode:	PCS1900	Test channel:	810
------------	---------	---------------	-----

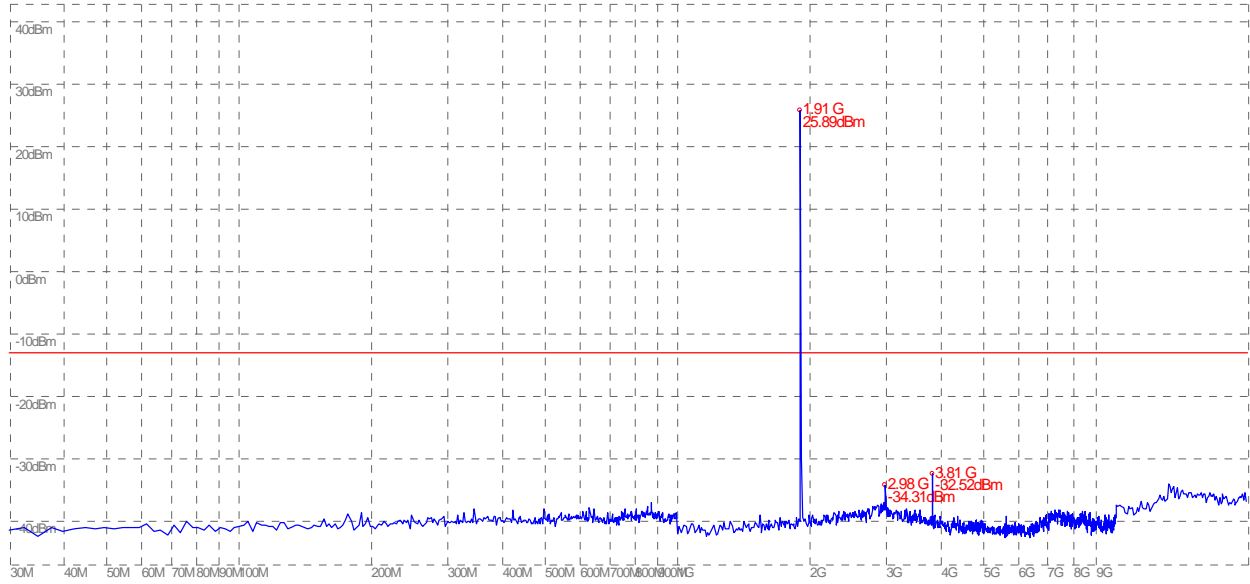

11.4.2 Band edge emission

Test mode:	GSM850	Test channel:	128
------------	--------	---------------	-----

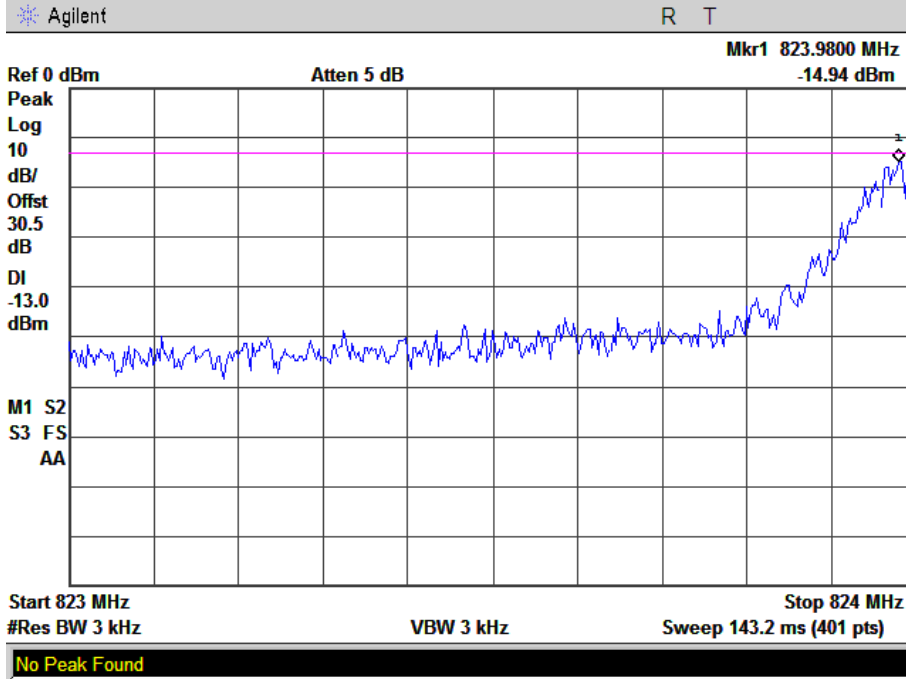

Test mode:	GSM850	Test channel:	251
------------	--------	---------------	-----

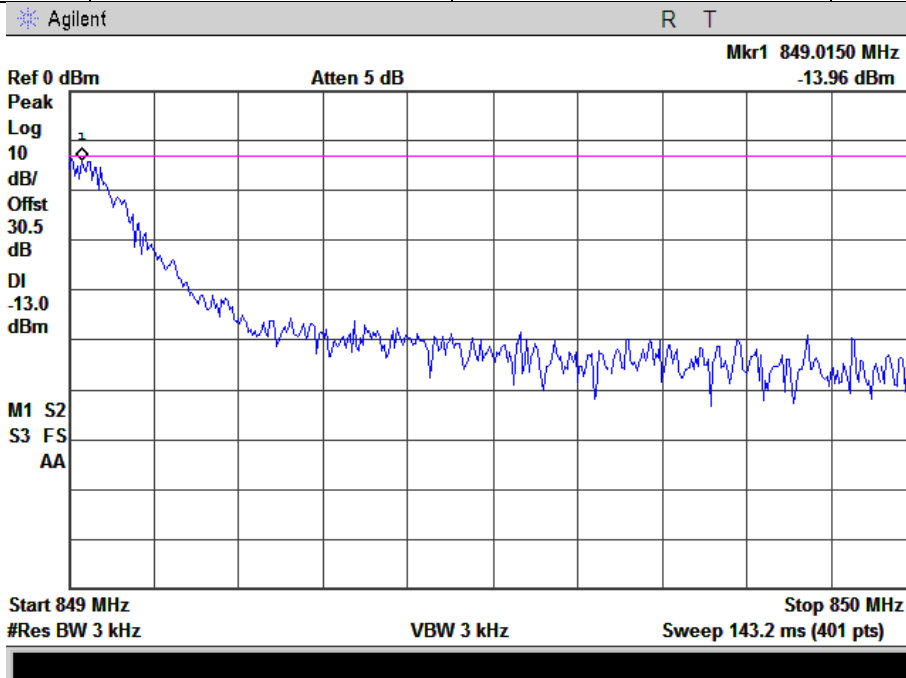

Test mode:	PCS1900	Test channel:	512
------------	---------	---------------	-----

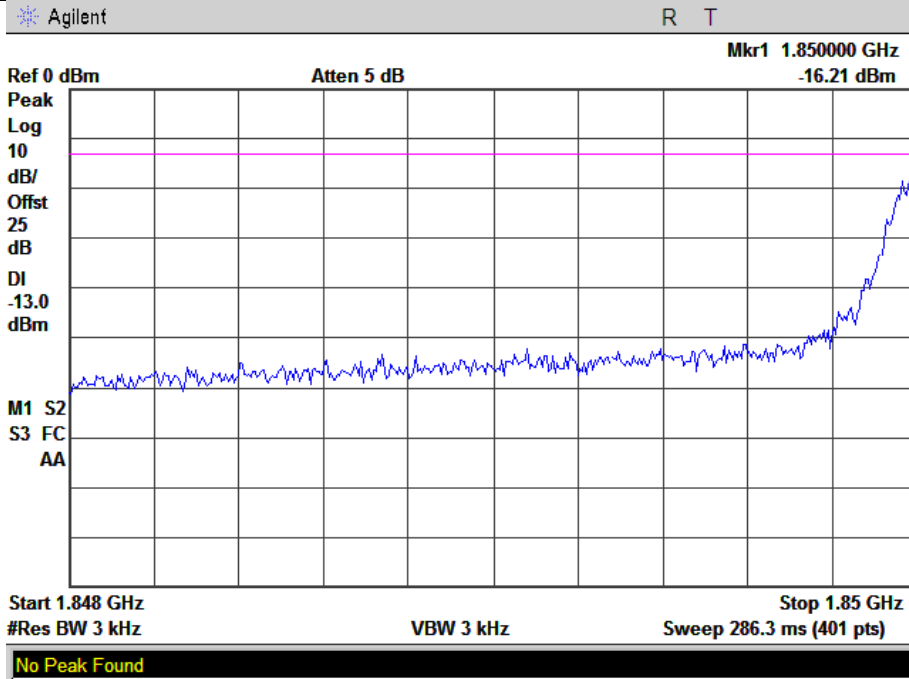

Test mode:	PCS1900	Test channel:	810
------------	---------	---------------	-----

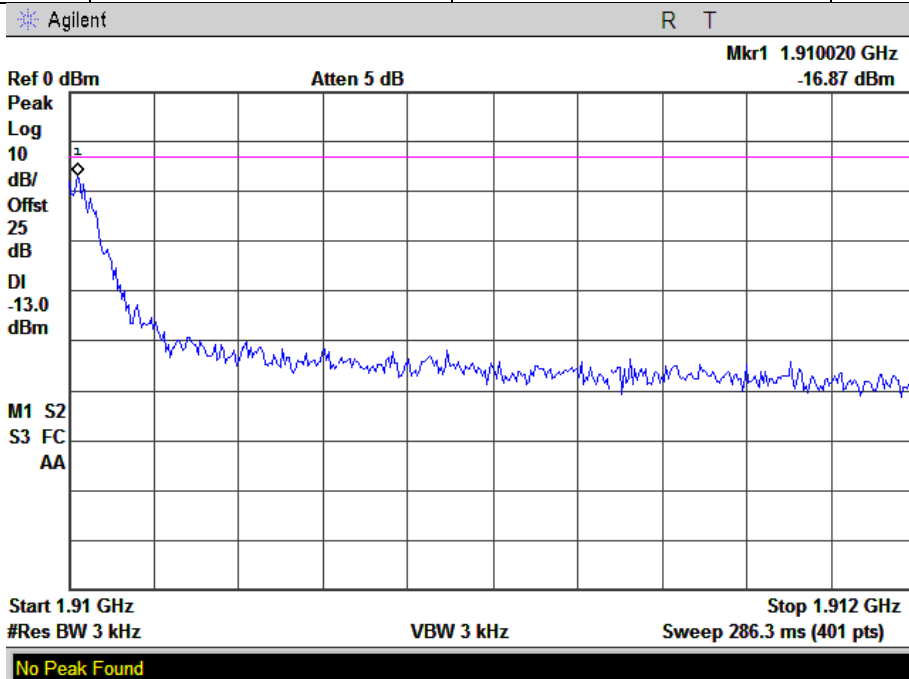

12 FIELD STRENGTH OF SPURIOUS RADIATION MEASUREMENT

12.1 Standard Applicable

According to FCC §2.1053,

FCC §22.917(a), §24.238(a), the magnitude of each spurious and harmonic emission that can be detected when the equipment is operated under the conditions specified in the instruction manual and/ or alignment procedure, shall not be less than $43 + 10 \log$ (mean output power in watts) dBc below the mean power output outside a license's frequency block (-13dBm)

12.2 EUT Setup (Block Diagram of Configuration)

(A) Radiated Emission Test Set-Up, Frequency below 1000MHz

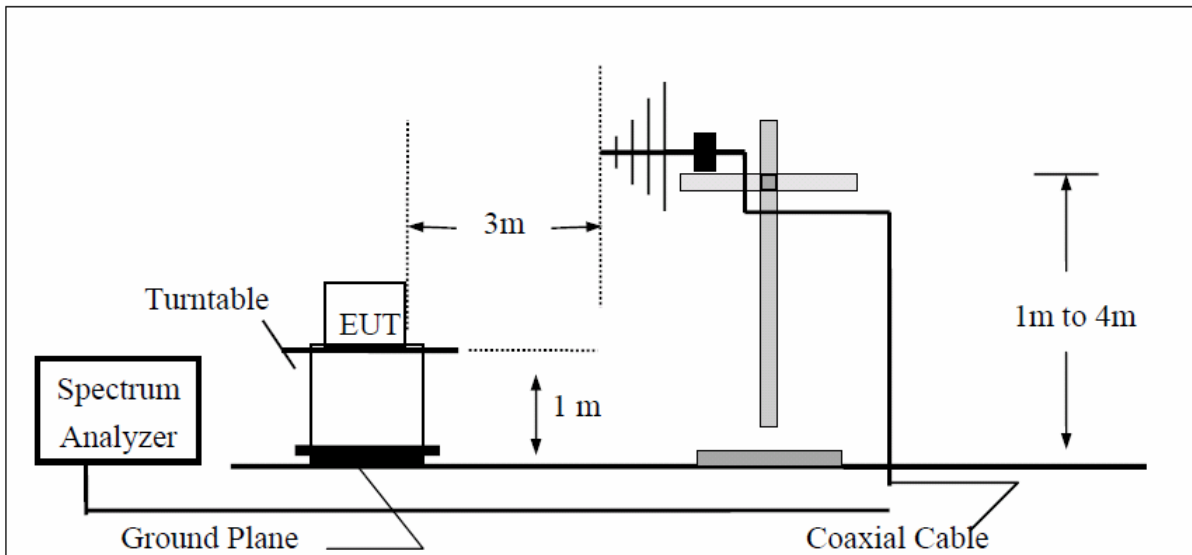

(B) Radiated Emission Test Set-UP Frequency over 1 GHz

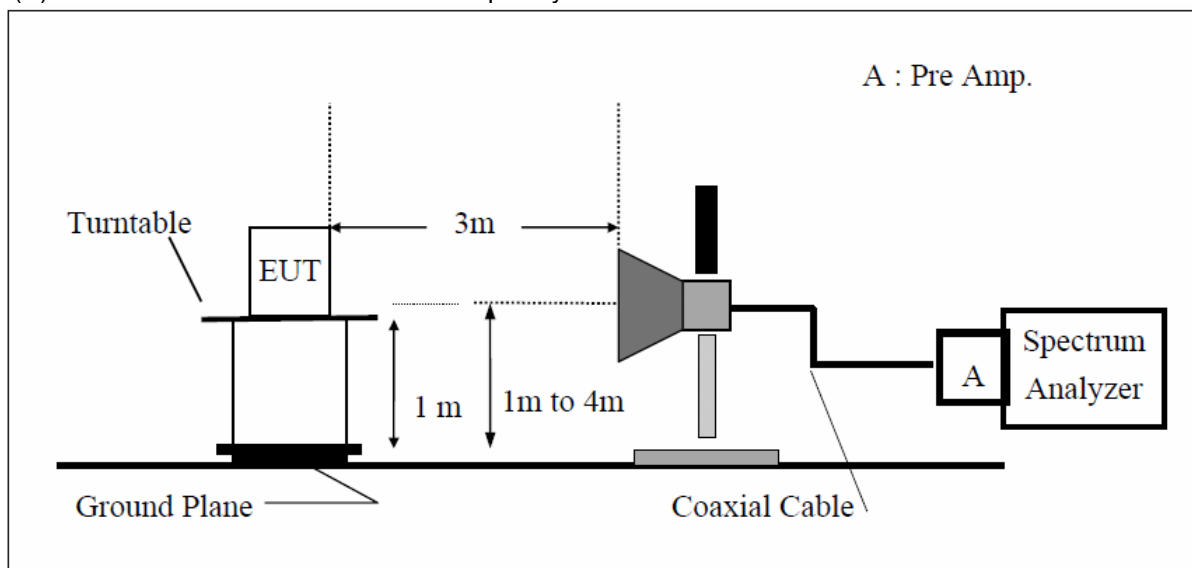

(C) Substituted Method Test Set-UP

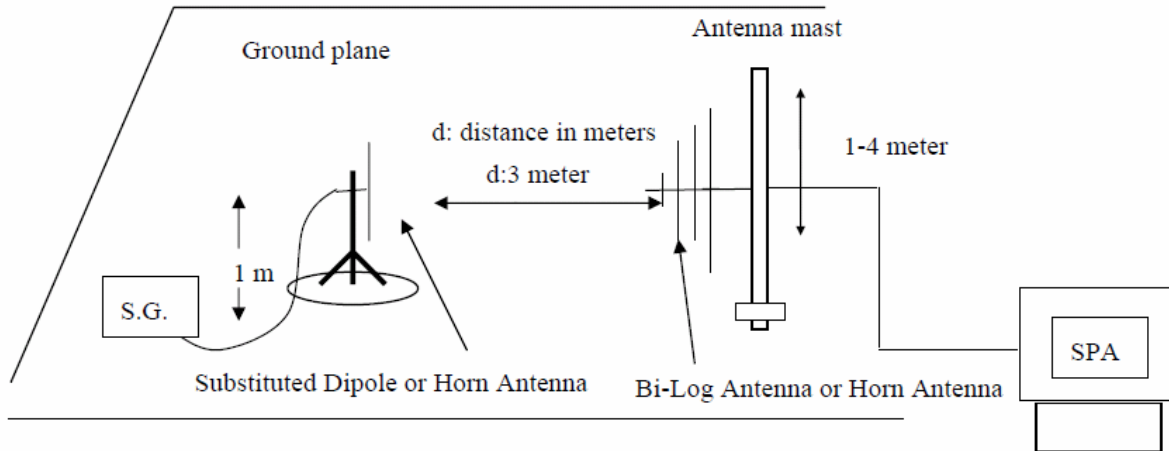

12.3 Measurement Procedure

The EUT was placed on a non-conductive, The measurement antenna was placed at a distance of 3 meters from the EUT. During the tests, the antenna height and the EUT azimuth were varied in order to identify the maximum level of emissions from the EUT. This maximization process was repeated with the EUT positioned in each of its three orthogonal orientations.

The frequency range up to tenth harmonic was investigated for each of three fundamental frequency (low, middle and high channels). Once spurious emission were identified, the power of the emission was determined using the substitution method.

The spurious emissions attenuation was calculated as the difference between radiated power at the fundamental frequency and the spurious emissions frequency.

$$\text{EIRP} = \text{S.G. output (dBm)} + \text{Antenna Gain(dBi)} - \text{Cable Loss (dB)}$$

12.4 Test Result

Test mode:	GSM850	Test channel:	128	EUT position	H
------------	--------	---------------	-----	--------------	---

Freq(MHz)	SPA reading	Ant. Pol.	S.G output (dBm)	Antenna Gain (dB/dBi)	Cable Loss (dB)	ERP/EIRP (dBm)	Limit (dBm)	Margin (dBm)
125.58	54.67	V	-50.03	-7.34	0.95	-58.32	-13.00	-45.32
561.84	50.71	V	-51.05	-7.76	1.37	-60.18	-13.00	-47.18
824.00	78.69	V	-7.31	-7.87	3.62	-18.80	-13.00	-5.80
1648.40	67.31	V	-37.27	9.29	5.23	-33.21	-13.00	-20.21
2472.60	63.76	V	-35.25	10.08	6.53	-31.70	-13.00	-18.70
3296.80	---	V				0.00	-13.00	13.00
4121.00	---	V				0.00	-13.00	13.00
4945.20	---	V				0.00	-13.00	13.00
5769.40	---	V				0.00	-13.00	13.00

Freq(MHz)	SPA reading	Ant. Pol.	S.G output (dBm)	Antenna Gain (dB/dBi)	Cable Loss (dB)	ERP/EIRP (dBm)	Limit (dBm)	Margin (dBm)
125.58	53.29	H	-53.50	-7.34	0.95	-61.79	-13.00	-48.79
561.84	52.91	H	-49.51	-7.76	1.37	-58.64	-13.00	-45.64
824.00	76.66	H	-9.73	-7.87	3.62	-21.22	-13.00	-8.22
1648.40	68.03	H	-37.79	9.29	5.23	-33.73	-13.00	-20.73
2472.60	67.08	H	-37.99	10.08	6.53	-34.44	-13.00	-21.44
3296.80	---	H					-13.00	
4121.00	---	H					-13.00	
4945.20	---	H					-13.00	
5769.40	---	H					-13.00	

Remark :

- 1 The emission behaviour belongs to narrowband spurious emission.
- 2 Remark"---" means that the emission level is too low to be measured
- 3 The result basic equation calculation is as follows:

$$\text{ERP/EIRP (dBm)} = \text{SG Setting(dBm)} + \text{Antenna Gain (dB/dBi)} - \text{Cable loss (dB)}$$

Test mode:	GSM850	Test channel:	190	EUT position	H
------------	--------	---------------	-----	--------------	---

Freq(MHz)	SPA reading	Ant. Pol.	S.G output (dBm)	Antenna Gain (dB/dBi)	Cable Loss (dB)	ERP/EIRP (dBm)	Limit (dBm)	Margin (dBm)
295.68	50.86	V	-45.98	-7.67	1.10	-54.75	-13.00	-41.75
651.27	47.78	V	-44.48	-7.83	1.58	-53.89	-13.00	-40.89
1673.20	67.44	V	-30.99	9.36	5.27	-26.90	-13.00	-13.90
2509.80	66.78	V	-35.76	10.09	6.58	-32.25	-13.00	-19.25
3346.40	69.23	V	-36.44	12.28	7.79	-31.95	-13.00	-18.95
4183.00	---	V					-13.00	
5019.60	---	V					-13.00	
5856.20	---	V					-13.00	
6692.80	---	V					-13.00	

Freq(MHz)	SPA reading	Ant. Pol.	S.G output (dBm)	Antenna Gain (dB/dBi)	Cable Loss (dB)	ERP/EIRP (dBm)	Limit (dBm)	Margin (dBm)
295.68	52.10	H	-46.17	-7.67	1.10	-54.94	-13.00	-41.94
651.27	52.01	H	-43.40	-7.83	1.58	-52.81	-13.00	-39.81
1673.20	69.29	H	-29.51	9.36	5.27	-25.42	-13.00	-12.42
2509.80	67.24	H	-36.51	10.09	6.58	-33.00	-13.00	-20.00
3346.40	66.82	H	-37.25	12.28	7.79	-32.76	-13.00	-19.76
4183.00	---	H					-13.00	
5019.60	---	H					-13.00	
5856.20	---	H					-13.00	
6692.80	---	H					-13.00	

Remark :

- 1 The emission behaviour belongs to narrowband spurious emission.
- 2 Remark"---" means that the emission level is too low to be measured
- 3 The result basic equation calculation is as follows:

$$\text{ERP/EIRP (dBm)} = \text{SG Setting(dBm)} + \text{Antenna Gain (dB/dBi)} - \text{Cable loss (dB)}$$

Test mode:	GSM850	Test channel:	251	EUT position	H
------------	--------	---------------	-----	--------------	---

Freq(MHz)	SPA reading	Ant. Pol.	S.G output (dBm)	Antenna Gain (dB/dBi)	Cable Loss (dB)	ERP/EIRP (dBm)	Limit (dBm)	Margin (dBm)
325.48	51.58	V	-49.09	-7.77	1.38	-58.24	-13.00	-45.24
748.51	49.75	V	-47.33	-7.88	2.88	-58.09	-13.00	-45.09
849.00	74.34	V	-8.20	-7.88	3.68	-19.76	-13.00	-6.76
1697.60	67.38	V	-36.47	9.44	5.31	-32.34	-13.00	-19.34
2546.40	68.52	V	-30.56	10.20	6.63	-26.99	-13.00	-13.99
3395.20	---	V					-13.00	
4244.00	---	V					-13.00	
5092.80	---	V					-13.00	
5941.60	---	V					-13.00	

Freq(MHz)	SPA reading	Ant. Pol.	S.G output (dBm)	Antenna Gain (dB/dBi)	Cable Loss (dB)	ERP/EIRP (dBm)	Limit (dBm)	Margin (dBm)
212.57	52.43	H	-44.94	-7.77	1.38	-54.09	-13.00	-41.09
598.68	52.46	H	-41.94	-7.88	2.88	-52.70	-13.00	-39.70
824.00	72.67	H	-9.80	-7.88	3.68	-21.36	-13.00	-8.36
1648.40	68.94	H	-35.78	9.44	5.31	-31.65	-13.00	-18.65
2472.60	69.63	H	-31.73	10.20	6.63	-28.16	-13.00	-15.16
3296.80	---	H					-13.00	
4121.00	---	H					-13.00	
4945.20	---	H					-13.00	
5769.40	---	H					-13.00	

Remark :

- 1 The emission behaviour belongs to narrowband spurious emission.
- 2 Remark"---" means that the emission level is too low to be measured
- 3 The result basic equation calculation is as follows:

$$\text{ERP/EIRP (dBm)} = \text{SG Setting(dBm)} + \text{Antenna Gain (dB/dBi)} - \text{Cable loss (dB)}$$

Test mode:	PCS1900	Test channel:	512	EUT position	H
------------	---------	---------------	-----	--------------	---

Freq(MHz)	SPA reading	Ant. Pol.	S.G output (dBm)	Antenna Gain (dB/dBi)	Cable Loss (dB)	ERP/EIRP (dBm)	Limit (dBm)	Margin (dBm)
527.54	54.67	V	-46.85	-7.83	1.41	-56.09	-13.00	-43.09
1387.27	50.71	V	-46.77	8.44	4.31	-42.64	-13.00	-29.64
1850.00	75.00	V	-23.79	9.90	5.56	-19.45	-13.00	-6.45
3700.40	70.07	V	-26.96	12.61	8.31	-22.66	-13.00	-9.66
5550.60	68.41	V	-30.34	13.23	10.33	-27.44	-13.00	-14.44
7400.80	---	V					-13.00	
9251.00	---	V					-13.00	
11101.20	---	V					-13.00	
12951.40	---	V					-13.00	

Freq(MHz)	SPA reading	Ant. Pol.	S.G output (dBm)	Antenna Gain (dB/dBi)	Cable Loss (dB)	ERP/EIRP (dBm)	Limit (dBm)	Margin (dBm)
527.54	53.96	H	-47.95	-7.83	1.41	-57.19	-13.00	-44.19
1578.41	49.37	H	-44.62	8.17	4.76	-41.21	-13.00	-28.21
1850.00	73.84	H	-25.18	9.90	5.56	-20.84	-13.00	-7.84
3700.40	68.06	H	-29.11	12.61	8.31	-24.81	-13.00	-11.81
5550.60	67.81	H	-31.10	13.23	10.33	-28.20	-13.00	-15.20
7400.80	---	H					-13.00	
9251.00	---	H					-13.00	
11101.20	---	H					-13.00	
12951.40	---	H					-13.00	

Remark :

- 1 The emission behaviour belongs to narrowband spurious emission.
- 2 Remark”---“ means that the emission level is too low to be measured
- 3 The result basic equation calculation is as follows:

$$\text{ERP/EIRP (dBm)} = \text{SG Setting(dBm)} + \text{Antenna Gain (dB/dBi)} - \text{Cable loss (dB)}$$

Test mode:	PCS1900	Test channel:	661	EUT position	H
------------	---------	---------------	-----	--------------	---

Freq(MHz)	SPA reading	Ant. Pol.	S.G output (dBm)	Antenna Gain (dB/dBi)	Cable Loss (dB)	ERP/EIRP (dBm)	Limit (dBm)	Margin (dBm)
527.54	55.55	V	-45.90	-7.83	1.41	-55.14	-13.00	-42.14
1607.43	49.98	V	-43.91	8.19	4.82	-40.54	-13.00	-27.54
3760.00	71.87	V	-26.64	12.60	8.39	-22.43	-13.00	-9.43
5640.00	65.99	V	-33.33	13.36	10.41	-30.38	-13.00	-17.38
7520.00	66.54	V	-32.38	11.45	12.19	-33.12	-13.00	-20.12
9400.00	---	V					-13.00	
11280.00	---	V					-13.00	
13160.00	---	V					-13.00	
15040.00	---	V					-13.00	

Freq(MHz)	SPA reading	Ant. Pol.	S.G output (dBm)	Antenna Gain (dB/dBi)	Cable Loss (dB)	ERP/EIRP (dBm)	Limit (dBm)	Margin (dBm)
527.54	56.83	H	-45.05	-7.83	1.41	-54.29	-13.00	-41.29
1201.45	50.23	H	-45.43	7.89	4.58	-42.12	-13.00	-29.12
3760.00	72.73	H	-26.36	12.60	8.39	-22.15	-13.00	-9.15
5640.00	66.53	H	-32.03	13.36	10.41	-29.08	-13.00	-16.08
7520.00	68.43	H	-30.80	11.45	12.19	-31.54	-13.00	-18.54
9400.00	---	H					-13.00	
11280.00	---	H					-13.00	
13160.00	---	H					-13.00	
15040.00	---	H					-13.00	

Remark :

- 1 The emission behaviour belongs to narrowband spurious emission.
- 2 Remark”---“ means that the emission level is too low to be measured
- 3 The result basic equation calculation is as follows:

$$\text{ERP/EIRP (dBm)} = \text{SG Setting(dBm)} + \text{Antenna Gain (dB/dBi)} - \text{Cable loss (dB)}$$

Test mode:	PCS1900	Test channel:	810	EUT position	H
------------	---------	---------------	-----	--------------	---

Freq(MHz)	SPA reading	Ant. Pol.	S.G output (dBm)	Antenna Gain (dB/dBi)	Cable Loss (dB)	ERP/EIRP (dBm)	Limit (dBm)	Margin (dBm)
527.54	55.55	V	-45.97	-7.83	1.41	-55.21	-13.00	-42.21
1388.22	50.98	V	-44.11	7.56	4.56	-41.11	-13.00	-28.11
1910.00	74.35	V	-22.88	10.08	5.66	-18.46	-13.00	-5.46
3819.60	63.89	V	-32.56	12.60	8.69	-28.65	-13.00	-15.65
5729.40	65.32	V	-32.12	13.86	10.73	-28.99	-13.00	-15.99
7639.20	---	V				0.00	-13.00	13.00
9549.00	---	V				0.00	-13.00	13.00
11458.80	---	V				0.00	-13.00	13.00
13368.60	---	V				0.00	-13.00	13.00

Freq(MHz)	SPA reading	Ant. Pol.	S.G output (dBm)	Antenna Gain (dB/dBi)	Cable Loss (dB)	ERP/EIRP (dBm)	Limit (dBm)	Margin (dBm)
527.54	54.84	H	-46.81	-7.83	1.41	-56.05	-13.00	-43.05
895.39	52.18	H	-43.85	-7.84	3.68	-55.37	-13.00	-42.37
1910.00	72.59	H	-24.56	10.08	5.66	-20.14	-13.00	-7.14
3819.60	62.09	H	-34.93	12.60	8.69	-31.02	-13.00	-18.02
5729.40	64.45	H	-35.31	13.86	10.73	-32.18	-13.00	-19.18
7639.20	---	H					-13.00	
9549.00	---	H					-13.00	
11458.80	---	H					-13.00	
13368.60	---	H					-13.00	

Remark :

- 1 The emission behaviour belongs to narrowband spurious emission.
- 2 Remark”---“ means that the emission level is too low to be measured
- 3 The result basic equation calculation is as follows:

$$\text{ERP/EIRP (dBm)} = \text{SG Setting(dBm)} + \text{Antenna Gain (dB/dBi)} - \text{Cable loss (dB)}$$

13 FREQUENCY STABILITY V.S. TEMPERATURE MEASUREMENT

13.1 Standard Applicable

According to FCC §2.1055(a)(1)(b).

Frequency Tolerance: 2.5 ppm

13.2 Test setup

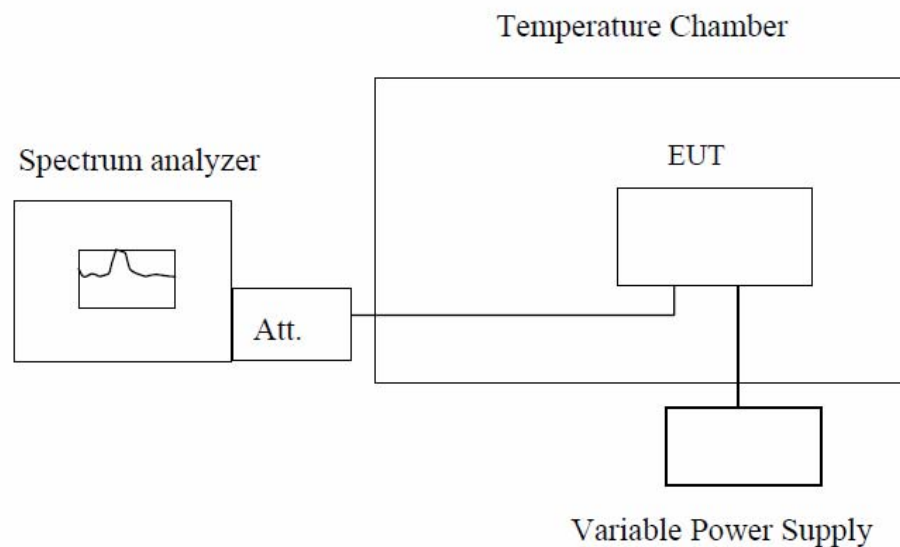

Note : Measurement setup for testing on Antenna connector

13.3 Test Procedure

The equipment under test was connected to an external AC or DC power supply and input rated voltage. RF output was connected to a frequency counter or spectrum analyzer via feed through attenuators. The EUT was placed inside the temperature chamber. Set the spectrum analyzer RBW low enough to obtain the desired frequency resolution and measure EUT 25°C operating frequency as reference frequency. Turn EUT off and set the chamber temperature to -30°C. After the temperature stabilized for approximately 30 minutes recorded the frequency. Repeat step measure with 10°C increased per stage until the highest temperature of +50°C reached.

13.4 Test Result

Reference Frequency: GSM850 Middle channel=190 channel=836.6MHz				
Temperature (°C)	Power Supplied (Vdc)	Frequency Error (Hz)	Frequency Error (ppm)	Limit (ppm)
-20	3.7	32	0.0383	2.5
-10	3.7	33	0.0394	2.5
0	3.7	31	0.0371	2.5
10	3.7	34	0.0406	2.5
20	3.7	36	0.0430	2.5
30	3.7	34	0.0406	2.5
40	3.7	36	0.0430	2.5
50	3.7	32	0.0383	2.5

Reference Frequency: PCS1900 Middle channel=661 channel=1880MHz				
Temperature (°C)	Power Supplied (Vdc)	Frequency Error (Hz)	Frequency Error (ppm)	Limit (ppm)
-20	3.7	37	0.0197	2.5
-10	3.7	41	0.0218	2.5
0	3.7	33	0.0176	2.5
10	3.7	35	0.0186	2.5
20	3.7	31	0.0165	2.5
30	3.7	34	0.0181	2.5
40	3.7	39	0.0207	2.5
50	3.7	43	0.0229	2.5

14 FREQUENCY STABILITY V.S. VOLTAGE MEASUREMENT

14.1 Standard Applicable

According to FCC §2.1055(d)(1)(2).

Frequency Tolerance: 2.5 ppm

14.2 Test setup

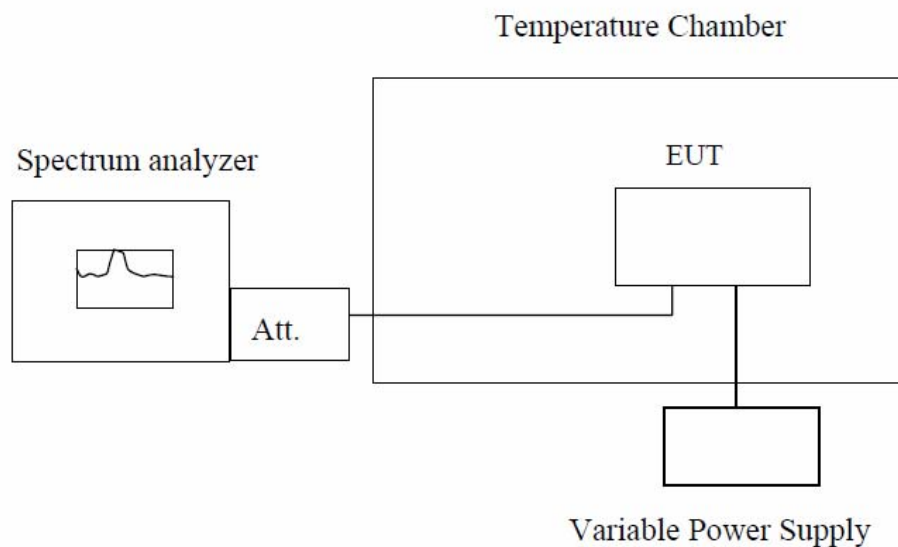

Note : Measurement setup for testing on Antenna connector

14.3 Test Procedure

Set chamber temperature to 25°C. Use a variable AC power supply / DC power source to power the EUT and set the voltage to rated voltage. Set the spectrum analyzer RBW low enough to obtain the desired frequency resolution and recorded the frequency.

Reduce the input voltage to specified extreme voltage variation (+/- 15%) and endpoint, record the maximum frequency change.

14.4 Test Result

Reference Frequency: GSM850 Middle channel=190 channel=836.6MHz				
Temperature (°C)	Power Supplied (Vdc)	Frequency Error (Hz)	Frequency Error (ppm)	Limit (ppm)
25	4.25	32	0.0383	2.5
25	3.7	34	0.0406	2.5
25	3.4	31	0.0371	2.5

Reference Frequency: PCS1900 Middle channel=661 channel=1880MHz				
Temperature (°C)	Power Supplied (Vdc)	Frequency Error (Hz)	Frequency Error (ppm)	Limit (ppm)
25	4.25	39	0.0207	2.5
25	3.7	31	0.0165	2.5
25	3.4	44	0.0234	2.5

15 AC POWER LINE CONDUCTED EMISSION TEST

15.1 Standard Applicable

According to FCC §15.207. The emission value for frequency within 150KHz to 30MHz shall not Exceed criteria of below chart.

Frequency range (MHz)	Limits dB(uV)	
	Quasi-peak	Average
0.15 to 0.50	66 to 56	56 to 46
0.50 to 5	56	46
5 to 30	60	50
<p>Note</p> <p>1.The lower limit shall apply at the transition frequencies</p> <p>2.The limit decreases linearly with the logarithm of the frequency in the range 0.15 MHz to 0.50 MHz.</p>		

15.2 Test setup

1. The conducted emission tests were performed in the test site, using the setup in accordance with the ANSI C63.4-2001.
2. The EUT was plug-in DC power adaptor and was placed on the center of the back edge on the test table. The peripherals like earphone was placed on the side of the EUT. The rear of the EUT and peripherals were placed flushed with the rear of the tabletop.
3. The Power adaptor was connected with 110Vac/60Hz power source.

15.3 Test Procedure

1. The EUT was placed on a table which is 0.8m above ground plane.
2. Maximum procedure was performed on the six highest emissions to ensure EUT compliance.
3. Repeat above procedures until all frequency measured were complete.

15.4 Measurement Result

Test mode: GSM850

Line:

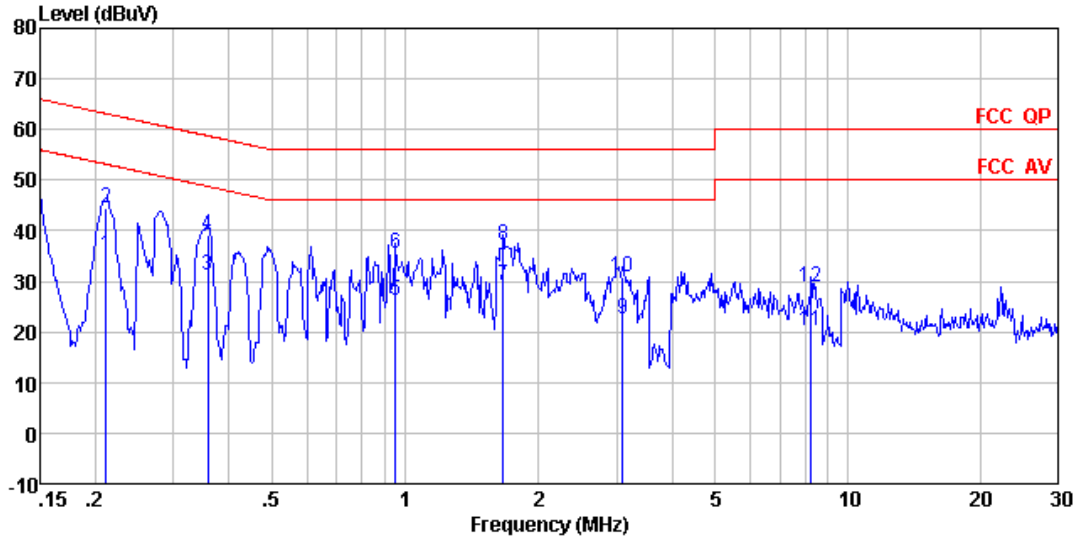

Condition : FCC QP LISN(2011) LINE
 Job No. : 195RF
 Test Mode : Ccommunicate mode(GSM850)
 Test Engineer: Collin

	Read Freq	Level	LISN Factor	Cable Loss	Level	Limit Line	Over Limit	Remark
	MHz	dBuV	dB	dB	dBuV	dBuV	dB	
1	0.212	34.55	0.65	0.10	35.30	53.14	-17.84	Average
2	0.212	43.81	0.65	0.10	44.56	63.14	-18.58	QP
3	0.360	30.62	0.59	0.10	31.31	48.74	-17.43	Average
4	0.360	38.39	0.59	0.10	39.08	58.74	-19.66	QP
5	0.953	25.66	0.48	0.10	26.24	46.00	-19.76	Average
6	0.953	34.84	0.48	0.10	35.42	56.00	-20.58	QP
7	1.662	28.57	0.42	0.10	29.09	46.00	-16.91	Average
8	1.662	36.49	0.42	0.10	37.01	56.00	-18.99	QP
9	3.090	22.25	0.35	0.10	22.70	46.00	-23.30	Average
10	3.090	30.43	0.35	0.10	30.88	56.00	-25.12	QP
11	8.235	19.69	0.24	0.18	20.11	50.00	-29.89	Average
12	8.235	28.35	0.24	0.18	28.77	60.00	-31.23	QP

Neutral:

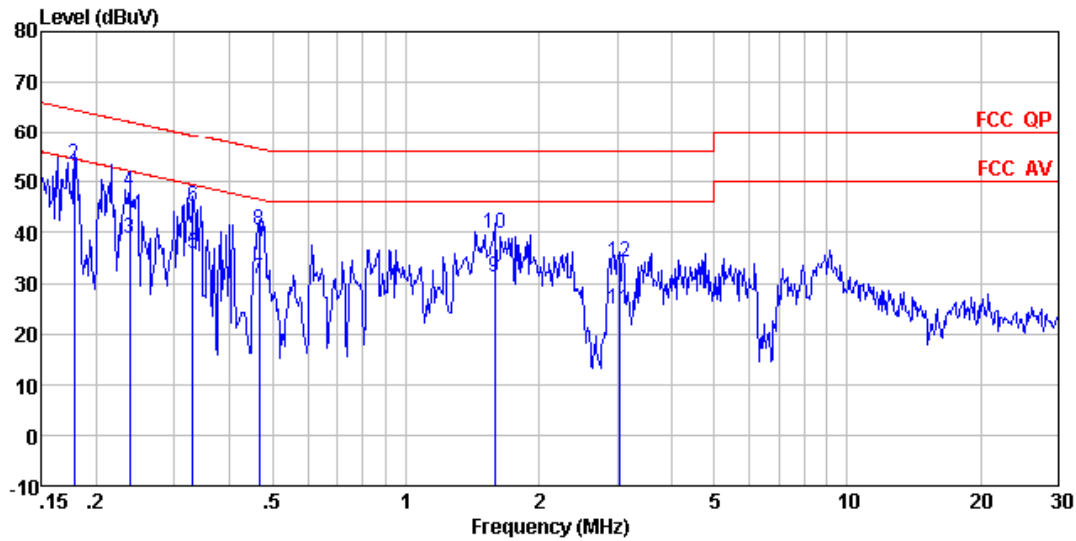

Condition : FCC QP LISN(2011) NEUTRAL
 Job No. : 195RF
 Test Mode : Communicate mode(GSM850)
 Test Engineer: Collin

	Freq	Read Level	LISN Factor	Cable Loss	Level	Limit Line	Over Limit	Remark
	MHz	dBuV	dB	dB	dBuV	dBuV	dB	
1	0.179	43.58	0.67	0.10	44.35	54.55	-10.20	Average
2	0.179	52.60	0.67	0.10	53.37	64.55	-11.18	QP
3	0.238	38.11	0.64	0.10	38.85	52.17	-13.32	Average
4	0.238	47.40	0.64	0.10	48.14	62.17	-14.03	QP
5	0.330	35.28	0.60	0.10	35.98	49.44	-13.46	Average
6	0.330	44.51	0.60	0.10	45.21	59.44	-14.23	QP
7	0.466	30.21	0.56	0.10	30.87	46.58	-15.71	Average
8	0.466	39.80	0.56	0.10	40.46	56.58	-16.12	QP
9	1.585	30.62	0.43	0.10	31.15	46.00	-14.85	Average
10	1.585	39.25	0.43	0.10	39.78	56.00	-16.22	QP
11	3.025	24.55	0.35	0.10	25.00	46.00	-21.00	Average
12	3.025	33.70	0.35	0.10	34.15	56.00	-21.85	QP

Test mode: PCS1900

Line:

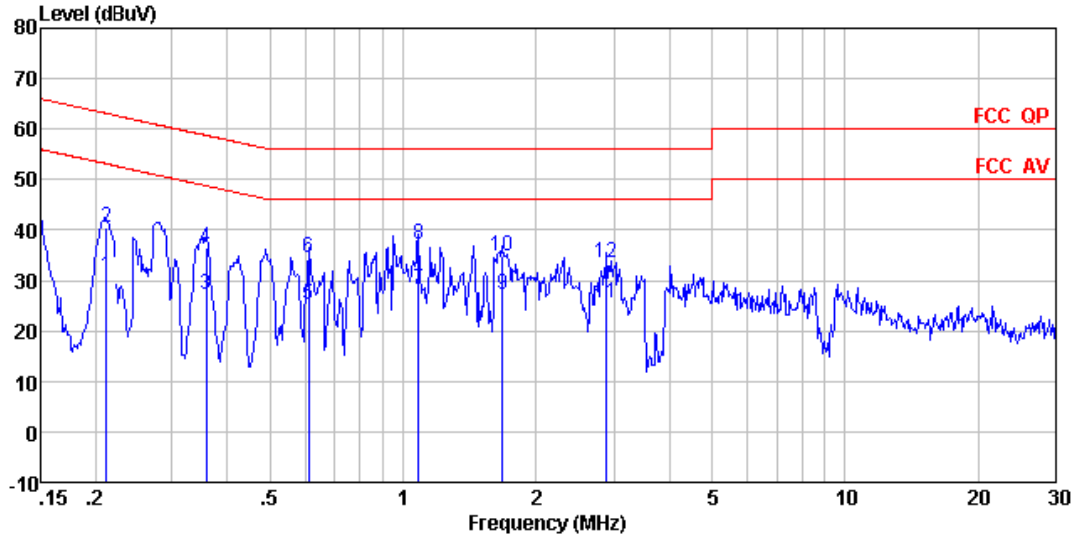

Condition : FCC QP LISN(2011) LINE
 Job No. : 195RF
 Test Mode : Communicate mode(PCS1900)
 Test Engineer: Collin

	Read Freq	Level	LISN Factor	Cable Loss	Level	Limit Line	Over Limit	Remark
	MHz	dBuV	dB	dB	dBuV	dBuV	dB	
1	0.212	30.19	0.65	0.10	30.94	53.14	-22.20	Average
2	0.212	39.88	0.65	0.10	40.63	63.14	-22.51	QP
3	0.360	26.54	0.59	0.10	27.23	48.74	-21.51	Average
4	0.360	35.75	0.59	0.10	36.44	58.74	-22.30	QP
5	0.611	24.67	0.53	0.10	25.30	46.00	-20.70	Average
6	0.611	33.93	0.53	0.10	34.56	56.00	-21.44	QP
7	1.082	27.48	0.47	0.10	28.05	46.00	-17.95	Average
8	1.082	36.51	0.47	0.10	37.08	56.00	-18.92	QP
9	1.680	26.84	0.42	0.10	27.36	46.00	-18.64	Average
10	1.680	34.29	0.42	0.10	34.81	56.00	-21.19	QP
11	2.884	25.18	0.36	0.10	25.64	46.00	-20.36	Average
12	2.884	33.08	0.36	0.10	33.54	56.00	-22.46	QP

Neutral:

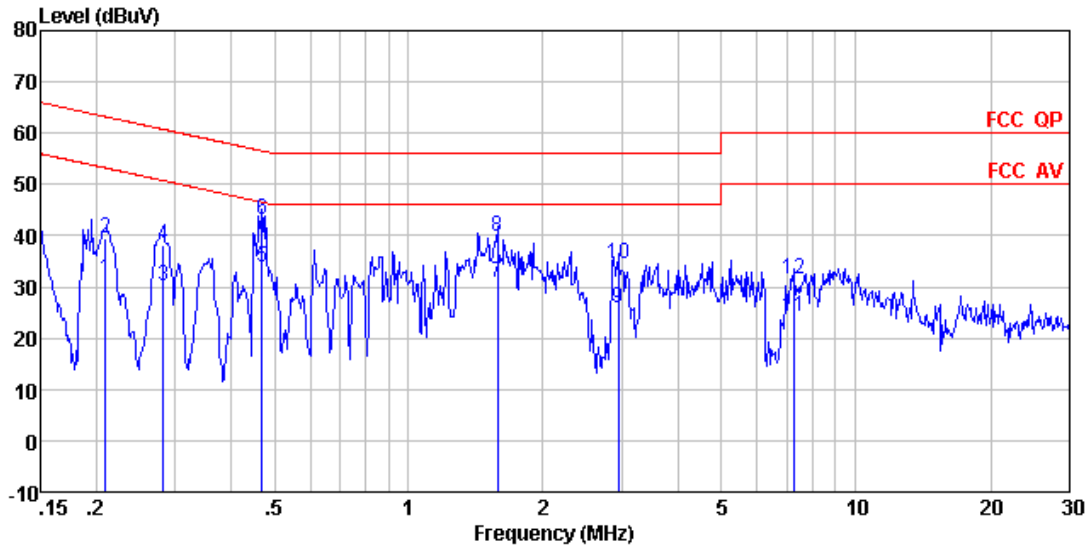

Condition : FCC QP LISN(2011) NEUTRAL
 Job No. : 195RF
 Test Mode : Communicate mode(PCS1900)
 Test Engineer: Collin

	Freq	Read Level	LISN Factor	Cable Loss	Level	Limit Line	Over Limit	Remark
	MHz	dBuV	dB	dB	dBuV	dBuV	dB	
1	0.209	30.62	0.65	0.10	31.37	53.23	-21.86	Average
2	0.209	38.86	0.65	0.10	39.61	63.23	-23.62	QP
3	0.282	29.56	0.62	0.10	30.28	50.76	-20.48	Average
4	0.282	37.43	0.62	0.10	38.15	60.76	-22.61	QP
5	0.469	33.33	0.56	0.10	33.99	46.54	-12.55	Average
6	0.469	42.34	0.56	0.10	43.00	56.54	-13.54	QP
7	1.585	30.25	0.43	0.10	30.78	46.00	-15.22	Average
8	1.585	39.31	0.43	0.10	39.84	56.00	-16.16	QP
9	2.946	25.46	0.36	0.10	25.92	46.00	-20.08	Average
10	2.946	33.96	0.36	0.10	34.42	56.00	-21.58	QP
11	7.252	23.64	0.26	0.16	24.06	50.00	-25.94	Average
12	7.252	31.19	0.26	0.16	31.61	60.00	-28.39	QP