



# FCC RF Test Report

APPLICANT : CORPORATIVO LANIX S.A. DE C.V.  
EQUIPMENT : Smart Mobile Phone  
BRAND NAME : LANIX  
MODEL NAME : ilium S200  
FCC ID : ZC4S200  
STANDARD : FCC Part 15 Subpart C §15.247  
CLASSIFICATION : (DSS) Spread Spectrum Transmitter

The product was received on May 03, 2013 and completely tested on May 28, 2013. We, SPORTON INTERNATIONAL (SHENZHEN) INC., would like to declare that the tested sample has been evaluated in accordance with the procedures and shown the compliance with the applicable technical standards.

The test results in this report apply exclusively to the tested model / sample. Without written approval of SPORTON INTERNATIONAL (SHENZHEN) INC., the test report shall not be reproduced except in full.

Reviewed by:

Jones Tsai / Manager



**SPORTON INTERNATIONAL (SHENZHEN) INC.**

**No. 3 Building, the third floor of south, Shahe River west, Fengzeyuan warehouse, Nanshan District,  
Shenzhen, Guangdong, P.R.C.**



## TABLE OF CONTENTS

**REVISION HISTORY..... 3**

**SUMMARY OF TEST RESULT ..... 4**

**1 GENERAL DESCRIPTION..... 5**

    1.1 Applicant..... 5

    1.2 Manufacturer..... 5

    1.3 Feature of Equipment Under Test ..... 5

    1.4 Product Specification of Equipment Under Test..... 5

    1.5 Testing Site..... 6

    1.6 Applied Standards ..... 6

**2 TEST CONFIGURATION OF EQUIPMENT UNDER TEST..... 7**

    2.1 Descriptions of Test Mode..... 7

    2.2 Test Mode..... 8

    2.3 Connection Diagram of Test System..... 9

    2.4 Support Unit used in test configuration and system..... 10

    2.5 Description of RF Function Operation Test Setup..... 10

    2.6 Measurement Results Explanation Example..... 10

**3 TEST RESULT ..... 12**

    3.1 Number of Channel Measurement ..... 12

    3.2 Hopping Channel Separation Measurement ..... 15

    3.3 Dwell Time Measurement..... 22

    3.4 20dB Bandwidth Measurement ..... 24

    3.5 Peak Output Power Measurement ..... 31

    3.6 Conducted Band Edges Measurement ..... 33

    3.7 Conducted Spurious Emission Measurement ..... 40

    3.8 Radiated Band Edges and Spurious Emission Measurement ..... 44

    3.9 AC Conducted Emission Measurement..... 54

    3.10 Antenna Requirements..... 58

**4 LIST OF MEASURING EQUIPMENT..... 59**

**5 UNCERTAINTY OF EVALUATION..... 60**

**APPENDIX A. PHOTOGRAPHS OF EUT**

**APPENDIX B. SETUP PHOTOGRAPHS**



## REVISION HISTORY

REPORT NO.	VERSION	DESCRIPTION	ISSUED DATE
FR350312A	Rev. 01	Initial issue of report	May 30, 2013

## SUMMARY OF TEST RESULT

Report Section	FCC Rule	Description	Limit	Result	Remark
3.1	15.247(a)(1)	Number of Channels	≥ 15Chs	Pass	-
3.2	15.247(a)(1)	Hopping Channel Separation	≥ 2/3 of 20dB BW	Pass	-
3.3	15.247(a)(1)	Dwell Time of Each Channel	≤ 0.4sec in 31.6sec period	Pass	-
3.4	15.247(a)(1)	20dB Bandwidth	NA	Pass	-
3.5	15.247(b)(1)	Peak Output Power	≤ 1 w for 1Mbps ≤ 125 Mw for 2, 3Mbps	Pass	-
3.6	15.247(d)	Conducted Band Edges	≤ 20dBc	Pass	-
3.7	15.247(d)	Conducted Spurious Emission	≤ 20dBc	Pass	-
3.8	15.247(d)	Radiated Band Edges and Radiated Spurious Emission	15.209(a) & 15.247(d)	Pass	Under limit 15.41 dB at 2399.000 MHz
3.9	15.207	AC Conducted Emission	15.207(a)	Pass	Under limit 9.68 dB at 0.780 MHz
3.10	15.203 & 15.247(b)	Antenna Requirement	N/A	Pass	-

# 1 General Description

## 1.1 Applicant

CORPORATIVO LANIX S.A. DE C.V.  
 CARRETERA INTERNACIONAL HERMOSILLO-NOGALE KM 8.5 HERMOSILLO MEXICO

## 1.2 Manufacturer

Shanghai Huaqin Telecom Technology Co.,Ltd  
 Building1, 399 Keyuan Road, Pudong district, Shanghai, China

## 1.3 Feature of Equipment Under Test

Product Feature	
Equipment	Smart Mobile Phone
Brand Name	LANIX
Model Name	ilium S200
FCC ID	ZC4S200
EUT supports Radios application	GSM/GPRS/WCDMA/HSPA/WLAN 11bgn / Bluetooth / Bluetooth v4.0-LE
HW Version	A51_MB_V2.0
SW Version	A51F_45A0_V8_0_3_20130320_DCC A51F_45A0_V0_0_P
EUT Stage	Production Unit

Remark: The above EUT's information was declared by manufacturer. Please refer to the specifications or user's manual for more detailed description.

## 1.4 Product Specification of Equipment Under Test

Product Specification subjective to this standard	
Tx/Rx Frequency Range	2402 MHz ~ 2480 MHz
Number of Channels	79
Carrier Frequency of Each Channel	2402+n*1 MHz; n=0~78
Maximum Output Power to Antenna	Bluetooth BDR (1Mbps) : 4.21 dBm (0.0026 W) Bluetooth EDR (2Mbps) : 3.62 dBm (0.0023 W) Bluetooth EDR (3Mbps) : 4.01 dBm (0.0025 W)
Antenna Type	PIFA Antenna type with gain -4 dBi
Type of Modulation	Bluetooth BDR (1Mbps) : GFSK Bluetooth EDR (2Mbps) : $\pi/4$ -DQPSK Bluetooth EDR (3Mbps) : 8-DPSK



### 1.5 Testing Site

<b>Test Site</b>	SPORTON INTERNATIONAL (SHENZHEN) INC.			
<b>Test Site Location</b>	No. 3 Building, the third floor of south, Shahe River west, Fengzeyuan warehouse, Nanshan District, Shenzhen, Guangdong, P.R.C. TEL: +86-755- 3320-2398			
<b>Test Site No.</b>	<b>Sporton Site No.</b>			<b>FCC/IC Registration No.</b>
	TH01-SZ	CO01-SZ	03CH01-SZ	149928/4086E-1

The test site complies with ANSI C63.4 2003 requirement.

### 1.6 Applied Standards

According to the specifications of the manufacturer, the EUT must comply with the requirements of the following standards:

- FCC Part 15 Subpart C §15.247
- FCC Public Notice DA 00-705
- ANSI C63.10-2009

**Remark:**

1. All test items were verified and recorded according to the standards and without any deviation during the test.
2. This EUT has also been tested and complied with the requirements of FCC Part 15, Subpart B, recorded in a separate test report.

## 2 Test Configuration of Equipment Under Test

### 2.1 Descriptions of Test Mode

Preliminary tests were performed in different data rate and recorded the RF output power in the following table:

Channel	Frequency	Bluetooth RF Output Power		
		Data Rate / Modulation		
		GFSK	$\pi/4$ -DQPSK	8-DPSK
		1Mbps	2Mbps	3Mbps
Ch00	2402MHz	2.24 dBm	1.52 dBm	1.92 dBm
Ch39	2441MHz	4.10 dBm	3.42 dBm	3.86 dBm
Ch78	2480MHz	4.21 dBm	3.62 dBm	4.01 dBm

**Remark:**

1. All the test data for each data rate were verified, but only the worst case was reported.
  2. The data rate was set in 1Mbps for all the test items due to the highest RF output power.
- 
- a. The EUT has been associated with peripherals pursuant to ANSI C63.10-2009 and configuration operated in a manner tended to maximize its emission characteristics in a typical application. Frequency range investigated: conduction (150 KHz to 30 MHz), radiation (9 KHz to the 10th harmonic of the highest fundamental frequency or to 40 GHz, whichever is lower). Pre-scanned tests, X, Y, Z in three orthogonal panels, and different data rates were conducted to determine the final configuration (Y plane as worst plane) from all possible combinations, and the worst mode of radiated spurious emissions is Bluetooth 3Mbps mode, and recorded in this report.
  - b. AC power line Conducted Emission was tested under maximum output power.

## 2.2 Test Mode

The following summary table is showing all test modes to demonstrate in compliance with the standard.

Summary table of Test Cases			
Test Item	Data Rate / Modulation		
	Bluetooth BDR 1Mbps GFSK	Bluetooth EDR 2Mbps $\pi/4$ -DQPSK	Bluetooth EDR 3Mbps 8-DPSK
Conducted Test Cases	Mode 1: CH00_2402 MHz	Mode 4: CH00_2402 MHz	Mode 7: CH00_2402 MHz
	Mode 2: CH39_2441 MHz	Mode 5: CH39_2441 MHz	Mode 8: CH39_2441 MHz
	Mode 3: CH78_2480 MHz	Mode 6: CH78_2480 MHz	Mode 9: CH78_2480 MHz
Radiated Test Cases	Bluetooth EDR 1Mbps GFSK		
	Mode 1: CH00_2402 MHz		
	Mode 2: CH39_2441 MHz		
	Mode 3: CH78_2480 MHz		
AC Conducted Emission	Mode 1 :GSM850 Idle + Bluetooth Link + WLAN Link + USB Cable (Charging from Adapter) + Earphone		
<p><b>Remark:</b> For radiated test cases, the worst mode data rate 1Mbps was reported only, because this data rate has the highest RF output power at preliminary tests, and the conducted spurious emissions and conducted band edge measurement for each data rate are no worse than 1Mbps, and no other significantly frequencies found in conducted spurious emission.</p>			



## 2.3 Connection Diagram of Test System

<Bluetooth Tx Mode>

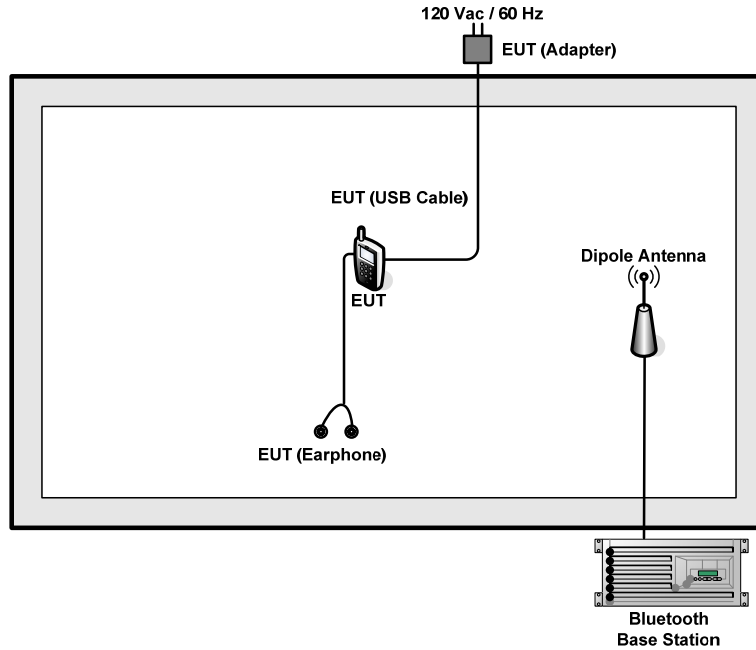

<AC Conducted Emission Mode>

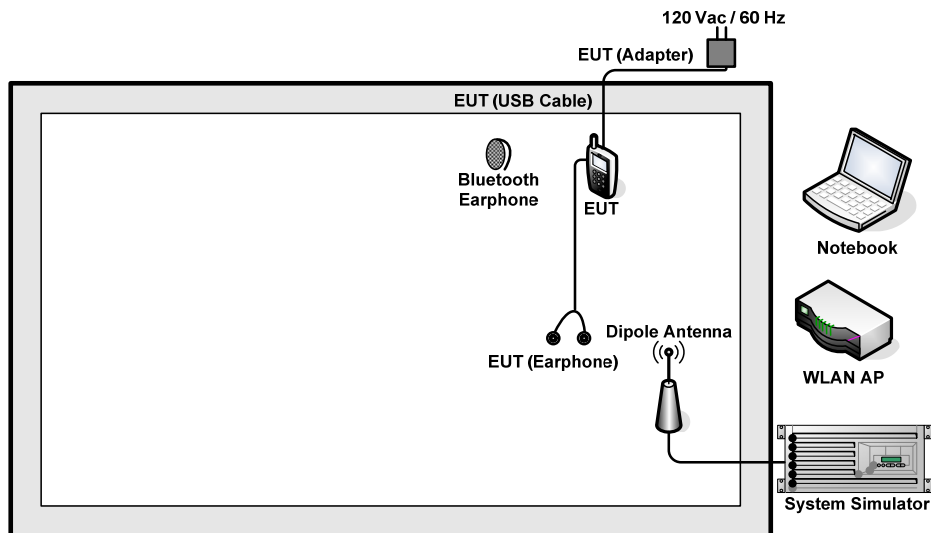

## 2.4 Support Unit used in test configuration and system

Item	Equipment	Trade Name	Model Name	FCC ID	Data Cable	Power Cord
1.	System Simulator	Agilent	E5515C	N/A	N/A	Unshielded, 1.8 m
2.	Bluetooth Base Station	R&S	CBT	FCC DoC	N/A	Unshielded, 1.8 m
3.	Bluetooth Base Station	Anritus	8852B	N/A	N/A	Unshielded, 1.8 m
4.	Base Station	Agilent	8960	N/A	N/A	Unshielded, 1.8 m
5.	DC Power Supply	TOPWORD	3303DR	N/A	N/A	Unshielded, 1.8 m
6.	WLAN AP	D-Link	DIR-612	N/A	N/A	Unshielded, 1.8 m
7.	Notebook	DELL	P08S	QDS-BRCM1030	N/A	AC I/P: Unshielded, 0.9 m DC O/P: Shielded, 1.8 m
8.	Notebook	DELL	VOSTRO 1440	N/A	N/A	Unshielded, 1.8 m
9.	Bluetooth Earphone	Nokia	BH108	N/A	N/A	N/A

## 2.5 Description of RF Function Operation Test Setup

For Bluetooth function, key in “\* # \* # 3646633 # \* # \*” on the EUT directly. Then, the EUT will get into the engineering modes to contact with Bluetooth base station for continuous transmitting and receiving signals.

## 2.6 Measurement Results Explanation Example

**For conducted test items:**

The offset level is set in the spectrum analyzer to compensate the RF cable loss and 10dB attenuator between EUT conducted output port and spectrum analyzer. With the offset compensation, the spectrum analyzer reading level is exactly the EUT RF output level.

The spectrum analyzer offset is derived from RF cable loss and 10dB attenuator factor.

*Offset = RF cable loss + attenuator factor.*

Following table shows an offset computation example with cable loss 5.6 dB.

Example :

$$\begin{aligned} \text{Offset(dB)} &= \text{RF cable loss(dB)} + \text{attenuator factor(dB)}. \\ &= 5.6 + 10 = 15.6 \text{ (dB)} \end{aligned}$$

**For radiated band edges and spurious emission test :**

Per part 15.35(c), the EUT Bluetooth average emission level could be determined by the peak emission level applying duty cycle correction factor, to represent averaging over the whole pulse train.

The average level is derived from the peak level corrected with “Duty cycle correction factor”.

$$\text{Average Emission Level(dBuV/m)} = \text{Peak Emission Level(dBuV/m)} + \text{Duty cycle correction factor(dB)}$$

$$\text{Duty cycle correction factor(dB)} = 20 * \log(\text{Duty cycle}).$$

Duty cycle = On time / 100 milliseconds

On time = dwell time \* hopping number in 100 ms

For example : bluetooth with dwell time 2.9ms and 2 hops in 100 ms, then

$$\text{Duty cycle correction factor(dB)} = 20 * \log( (2.9 * 2) / 100 ) = -24.73 \text{ dB}$$

Following shows an average computation example with duty cycle correction factor = -24.73dB, and the peak emission level is 45.61 dBuV/m.

Example :

$$\begin{aligned} \text{Average Emission Level(dBuV/m)} &= \text{Peak Emission Level(dBuV/m)} + \text{duty cycle correction factor(dB)} \\ &= 45.61 + ( -24.73 ) = 20.88 \text{ (dBuV/m)} \end{aligned}$$

### 3 Test Result

#### 3.1 Number of Channel Measurement

##### 3.1.1 Limits of Number of Hopping Frequency

Frequency hopping systems in the 2400-2483.5 MHz band shall use at least 15 channels.

##### 3.1.2 Measuring Instruments

See list of measuring instruments of this test report.

##### 3.1.3 Test Procedure

1. The testing follows FCC Public Notice DA 00-705 Measurement Guidelines.
2. The RF output of EUT was connected to the spectrum analyzer by RF cable and attenuator. The path loss was compensated to the results for each measurement.
3. Set to the maximum power setting and enable the EUT transmit continuously.
4. Enable the EUT hopping function.
5. Use the following spectrum analyzer settings: Span = the frequency band of operation; RBW  $\geq$  1% of the span; VBW  $\geq$  RBW; Sweep = auto; Detector function = peak; Trace = max hold.
6. The number of hopping frequency used is defined as the number of total channel.
7. Record the measurement data derived from spectrum analyzer.

##### 3.1.4 Test Setup

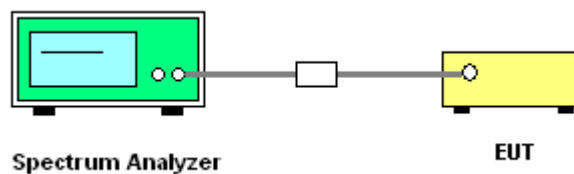

### 3.1.5 Test Result of Number of Hopping Frequency

Test Mode :	1Mbps	Temperature :	24~26°C
Test Engineer :	Fly Chen	Relative Humidity :	50~53%

  

Number of Hopping (Channel)	Adaptive Frequency Hopping (Channel)	Limits (Channel)	Pass/Fail
79	>= 20	> 15	Pass

Number of Hopping Channel Plot on Channel 00 - 78

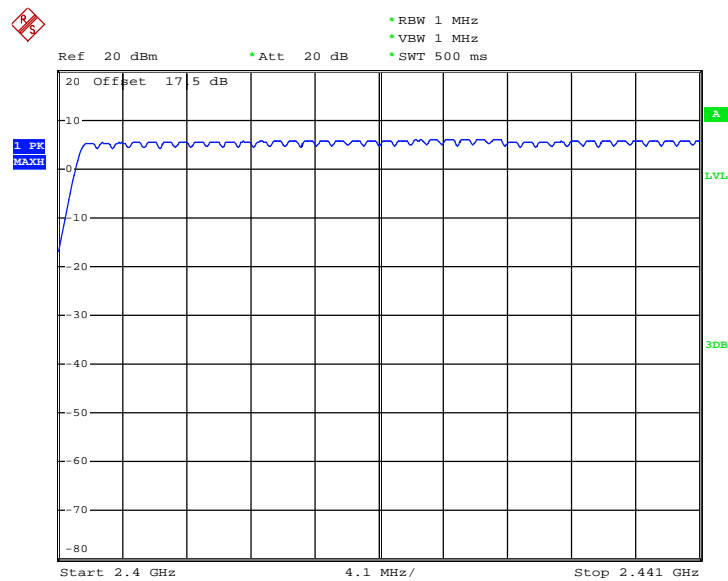

Date: 16.MAY.2013 16:40:54

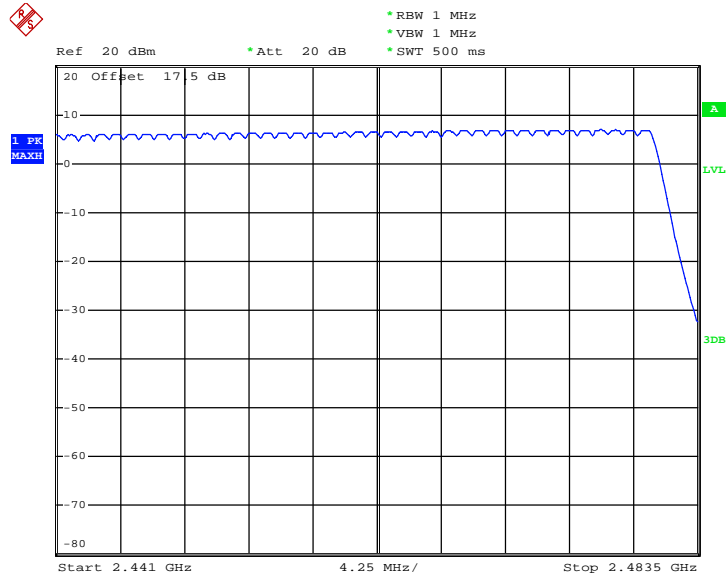

Date: 16.MAY.2013 16:48:05

## 3.2 Hopping Channel Separation Measurement

### 3.2.1 Limit of Hopping Channel Separation

Frequency hopping systems operating in the 2400-2483.5 MHz band may have hopping channel carrier frequencies that are separated by 25 KHz or two-thirds of the 20 dB bandwidth of the hopping channel, whichever is greater.

### 3.2.2 Measuring Instruments

See list of measuring instruments of this test report.

### 3.2.3 Test Procedures

1. The testing follows FCC Public Notice DA 00-705 Measurement Guidelines.
2. The RF output of EUT was connected to the spectrum analyzer by RF cable and attenuator. The path loss was compensated to the results for each measurement.
3. Set to the maximum power setting and enable the EUT transmit continuously.
4. Enable the EUT hopping function.
5. Use the following spectrum analyzer settings:  
Span = wide enough to capture the peaks of two adjacent channels;  $RBW \geq 1\%$  of the span;  
 $VBW \geq RBW$ ; Sweep = auto; Detector function = peak; Trace = max hold.
6. Measure and record the results in the test report.

### 3.2.4 Test Setup

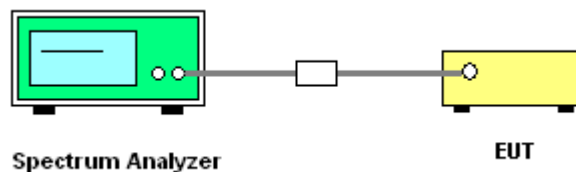



3.2.5 Test Result of Hopping Channel Separation

Test Mode :	1Mbps	Temperature :	24~26°C
Test Engineer :	Fly Chen	Relative Humidity :	50~53%

Channel	Frequency (MHz)	Frequency Separation (MHz)	(2/3 of 20dB BW) Limits (MHz)	Pass/Fail
00	2402	1.002	0.6053	Pass
39	2441	1.008	0.6080	Pass
78	2480	1.002	0.6053	Pass

Channel Separation Plot on Channel 00 - 01

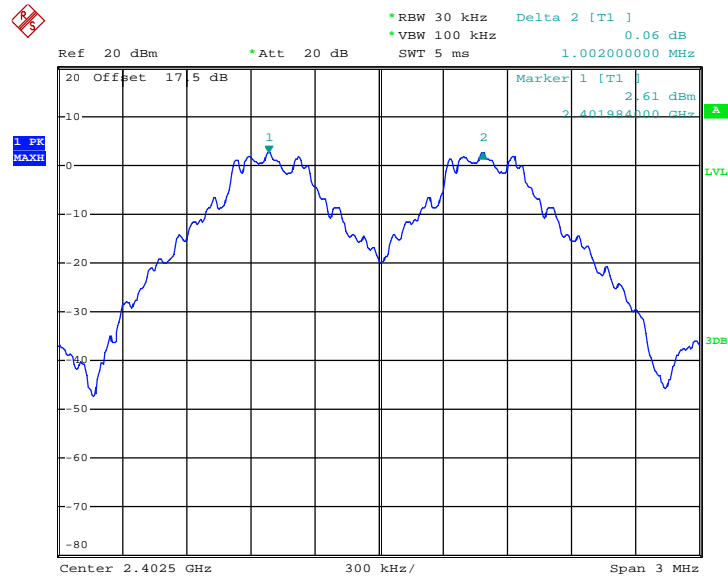

Date: 16.MAY.2013 15:58:01





Channel Separation Plot on Channel 39 - 40

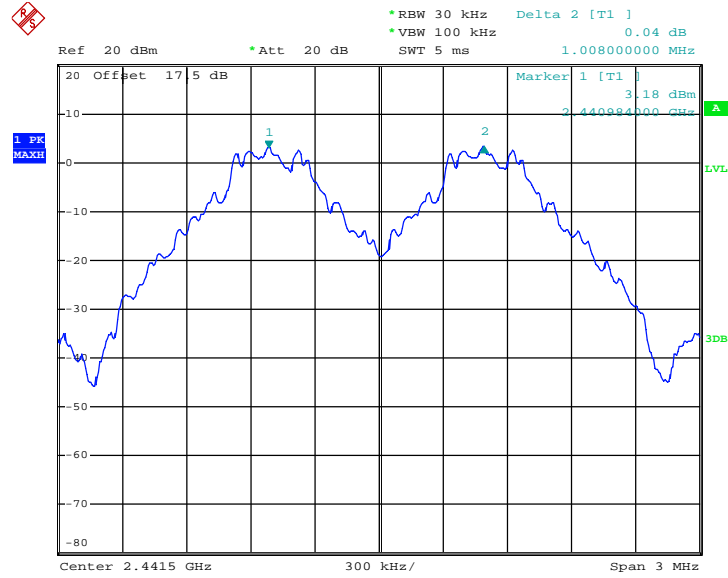

Date: 16.MAY.2013 15:58:37

Channel Separation Plot on Channel 77 - 78

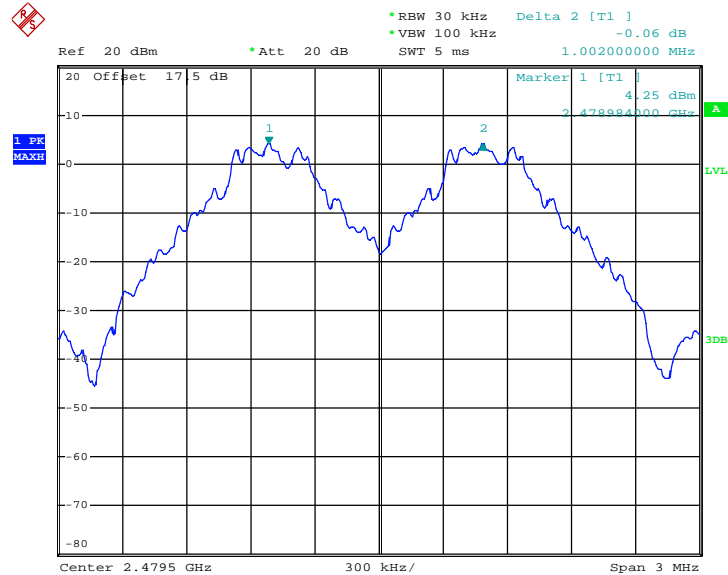

Date: 16.MAY.2013 15:59:14



Test Mode :	2Mbps	Temperature :	24~26°C
Test Engineer :	Fly Chen	Relative Humidity :	50~53%

Channel	Frequency (MHz)	Frequency Separation (MHz)	(2/3 of 20dB BW) Limits (MHz)	Pass/Fail
00	2402	1.008	0.8160	Pass
39	2441	1.002	0.8240	Pass
78	2480	1.002	0.8400	Pass

Channel Separation Plot on Channel 00 - 01

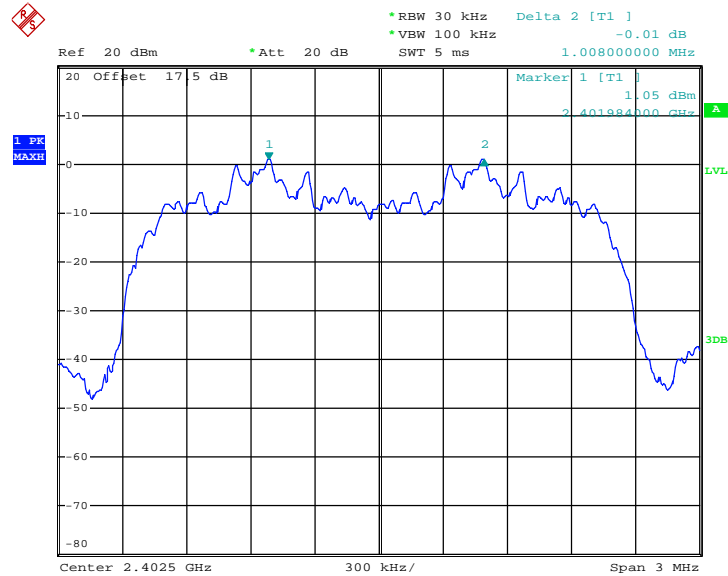

Date: 16.MAY.2013 16:07:20



### Channel Separation Plot on Channel 39 - 40

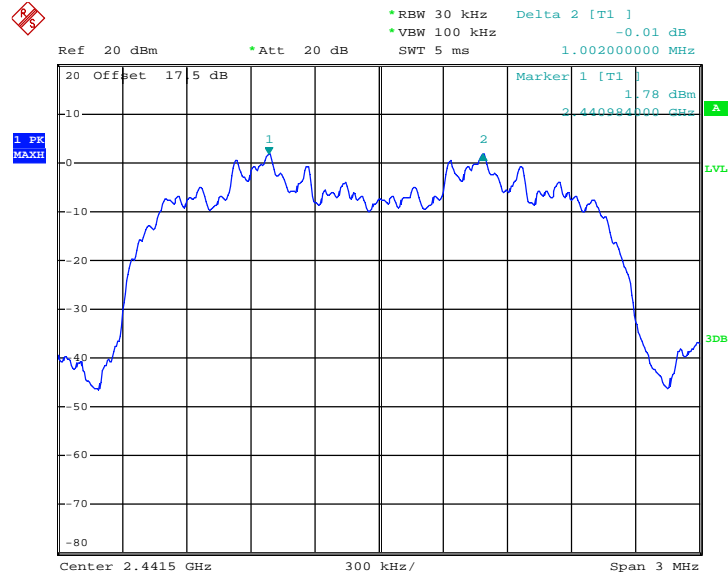

Date: 16.MAY.2013 16:06:40

### Channel Separation Plot on Channel 77 - 78

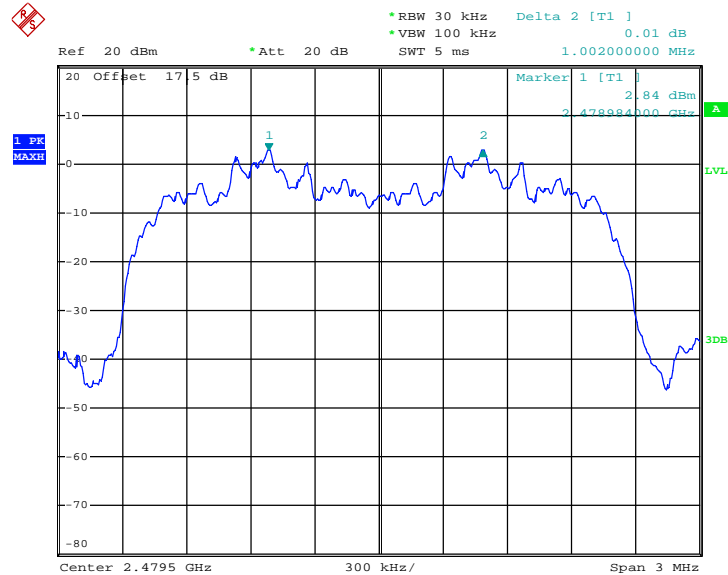

Date: 16.MAY.2013 16:05:57



Test Mode :	3Mbps	Temperature :	24~26°C
Test Engineer :	Fly Chen	Relative Humidity :	50~53%

Channel	Frequency (MHz)	Frequency Separation (MHz)	(2/3 of 20dB BW) Limits (MHz)	Pass/Fail
00	2402	1.002	0.8187	Pass
39	2441	1.002	0.8187	Pass
78	2480	1.002	0.8187	Pass

Channel Separation Plot on Channel 00 - 01

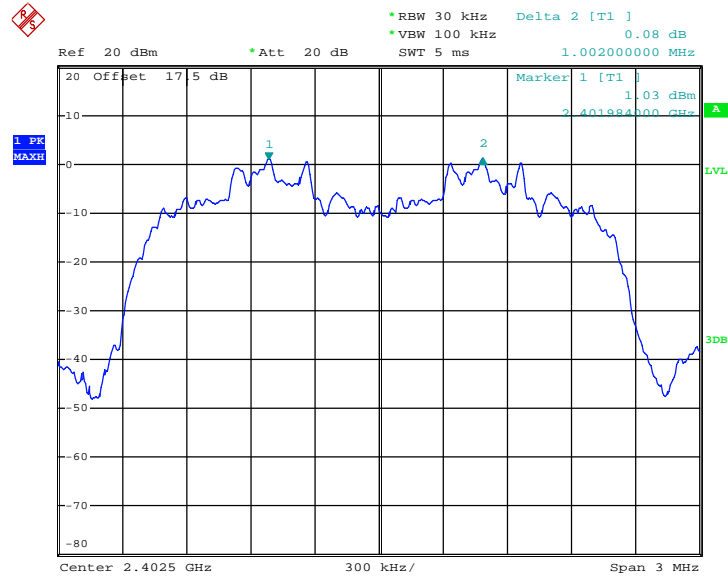

Date: 16.MAY.2013 16:08:01



Channel Separation Plot on Channel 39 - 40

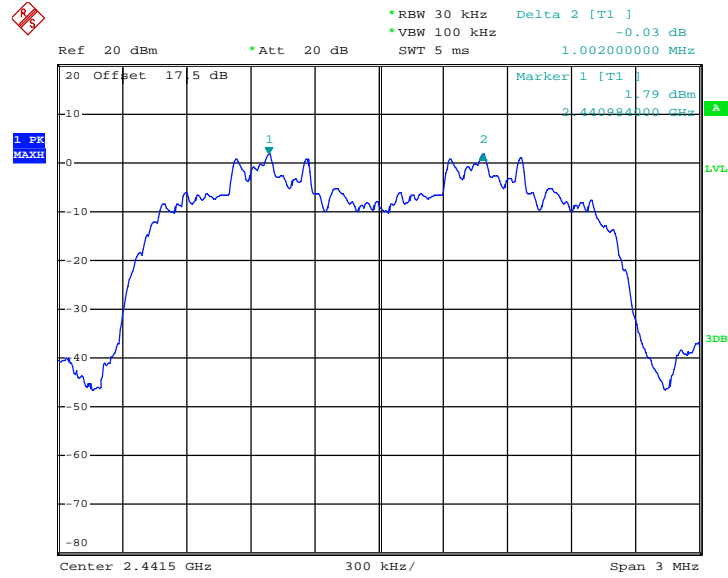

Date: 16.MAY.2013 16:08:33

Channel Separation Plot on Channel 77 - 78

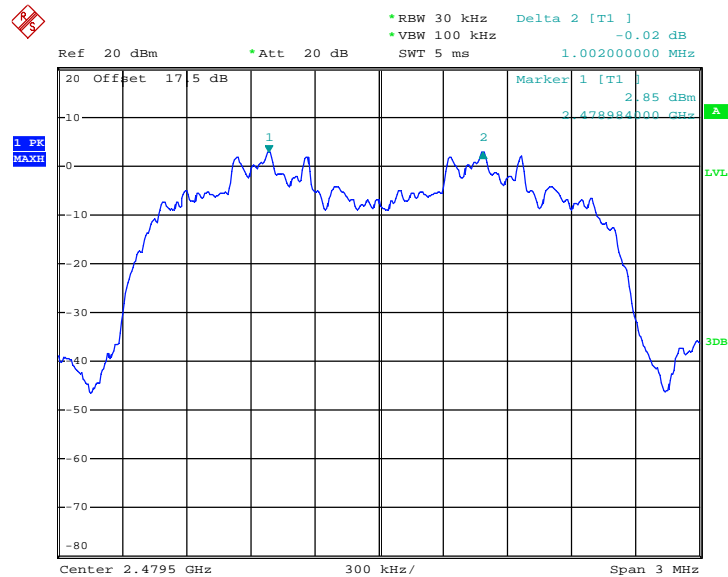

Date: 16.MAY.2013 16:09:12

### 3.3 Dwell Time Measurement

#### 3.3.1 Limit of Dwell Time

The average time of occupancy on any channel shall not be greater than 0.4 seconds within a period of 0.4 seconds multiplied by the number of hopping channels employed.

#### 3.3.2 Measuring Instruments

See list of measuring instruments of this test report.

#### 3.3.3 Test Procedures

1. The testing follows FCC Public Notice DA 00-705 Measurement Guidelines.
2. The RF output of EUT was connected to the spectrum analyzer by RF cable and attenuator. The path loss was compensated to the results for each measurement.
3. Set to the maximum power setting and enable the EUT transmit continuously.
4. Enable the EUT hopping function.
5. Use the following spectrum analyzer settings: Span = zero span, centered on a hopping channel; RBW = 1 MHz; VBW  $\geq$  RBW; Sweep = as necessary to capture the entire dwell time per hopping channel; Detector function = peak; Trace = max hold.
6. Measure and record the results in the test report.

#### 3.3.4 Test Setup

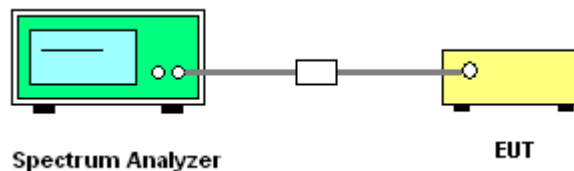

#### 3.3.5 Test Result of Dwell Time

Test Mode :	DH5	Temperature :	24~26°C
Test Engineer :	Fly Chen	Relative Humidity :	50~53%

Mode	Hopping Channel Number	Hops Over Occupancy Time(hops)	Package Transfer Time (msec)	Dwell Time (sec)	Limits (sec)	Pass/Fail
Normal	79	106.67	2.920	0.31	0.4	Pass
AFH	20	53.34	2.920	0.16	0.4	Pass

**Remark:**

1. In normal mode, hopping rate is 1600hops/s with 6 slots in 79 hopping channels.  
 With channel hopping rate (1600 / 6 / 79) in Occupancy Time Limit (0.4 x 79) (s),  
 Hops Over Occupancy Time comes to (1600 / 6 / 79) x (0.4 x 79) = 106.67 hops.
  
2. In AFH mode, hopping rate is 800hops/s with 6 slots in 20 hopping channels.  
 With channel hopping rate (800 / 6 / 20) in Occupancy Time Limit (0.4 x 20) (s),  
 Hops Over Occupancy Time comes to (800 / 6 / 20) x (0.4 x 20) = 53.34 hops.
  
3. Dwell Time(s) = Hops Over Occupancy Time (hops) x Package Transfer Time

**Package Transfer Time Plot**

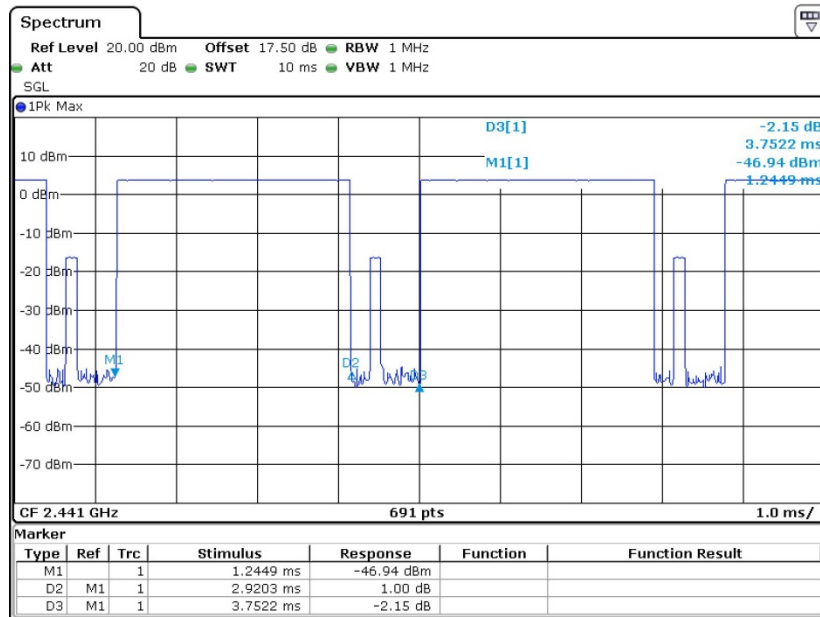

Date: 8.MAY.2013 08:21:50

### 3.4 20dB Bandwidth Measurement

#### 3.4.1 Limit of 20dB Bandwidth

Reporting only

#### 3.4.2 Measuring Instruments

See list of measuring instruments of this test report.

#### 3.4.3 Test Procedures

1. The testing follows FCC Public Notice DA 00-705 Measurement Guidelines.
2. The RF output of EUT was connected to the spectrum analyzer by RF cable and attenuator. The path loss was compensated to the results for each measurement.
3. Set to the maximum power setting and enable the EUT transmit continuously.
4. Use the following spectrum analyzer settings for 20dB Bandwidth measurement.  
Span = approximately 2 to 3 times the 20 dB bandwidth, centered on a hopping channel;  
RBW  $\geq$  1% of the 20 dB bandwidth; VBW  $\geq$  RBW; Sweep = auto; Detector function = peak;  
Trace = max hold.
5. Measure and record the results in the test report.

#### 3.4.4 Test Setup

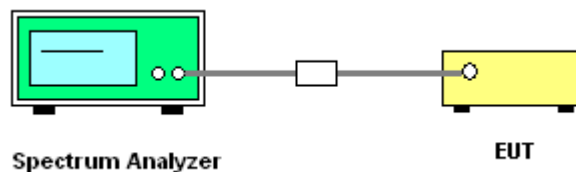





3.4.5 Test Result of 20dB Bandwidth

Test Mode :	1Mbps	Temperature :	24~26°C
Test Engineer :	Fly Chen	Relative Humidity :	50~53%

Channel	Frequency (MHz)	20dB Bandwidth (MHz)
00	2402	0.908
39	2441	0.912
78	2480	0.908

20 dB Bandwidth Plot on Channel 00

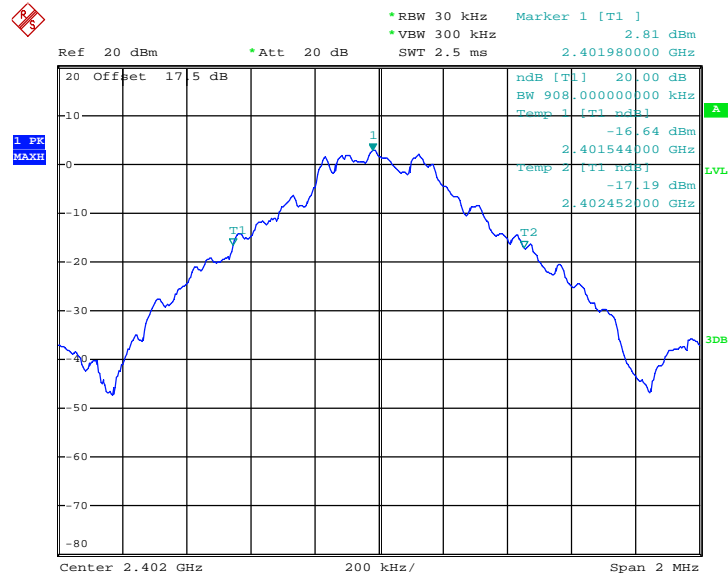

Date: 16.MAY.2013 15:31:10



### 20 dB Bandwidth Plot on Channel 39

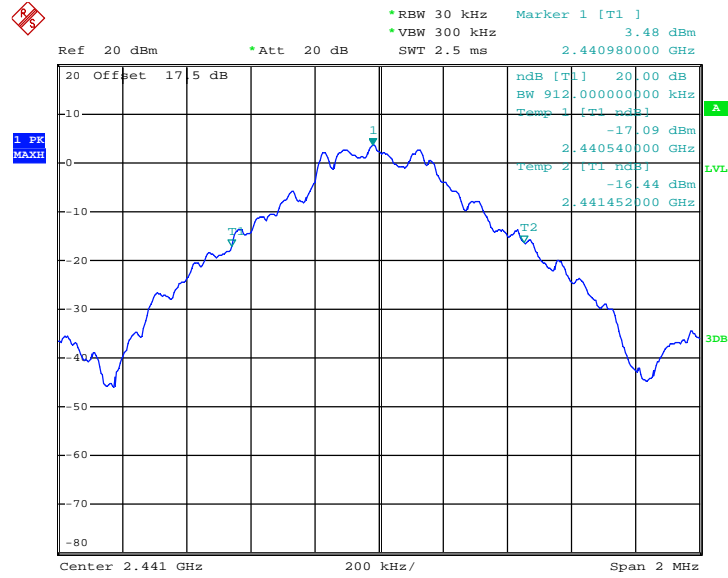

Date: 16.MAY.2013 15:30:48

### 20 dB Bandwidth Plot on Channel 78

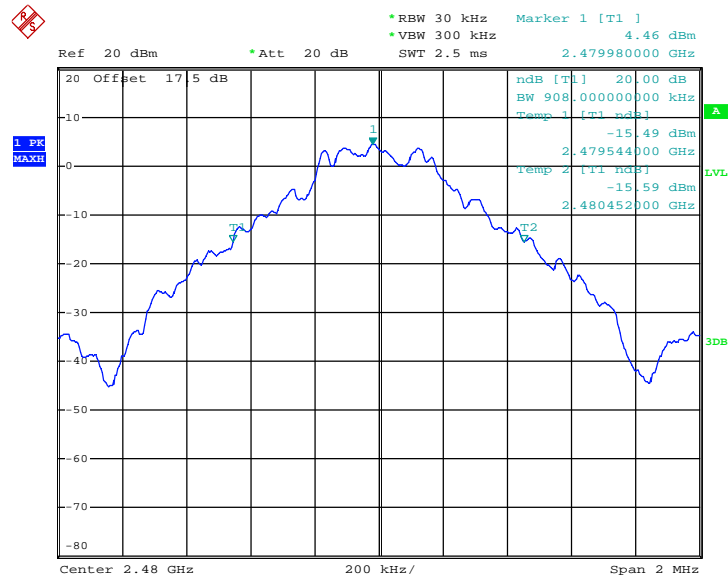

Date: 16.MAY.2013 15:30:26



Test Mode :	2Mbps	Temperature :	24~26°C
Test Engineer :	Fly Chen	Relative Humidity :	50~53%

Channel	Frequency (MHz)	20dB Bandwidth (MHz)
00	2402	1.224
39	2441	1.236
78	2480	1.260

20 dB Bandwidth Plot on Channel 00

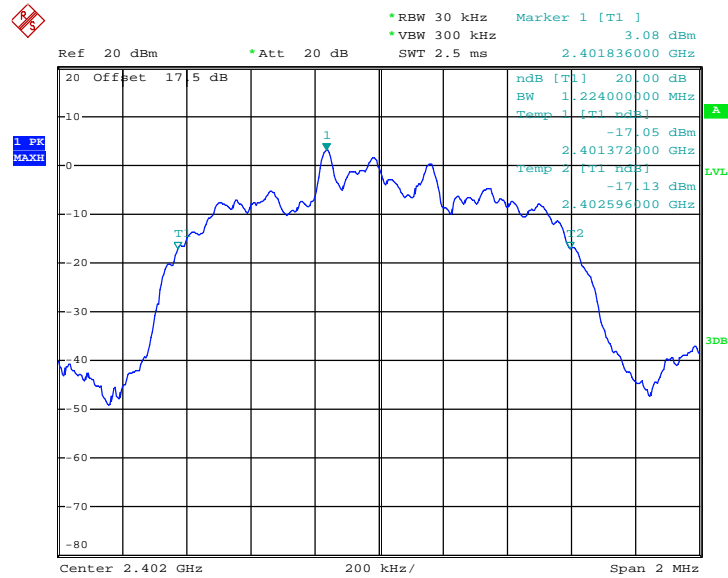

Date: 16.MAY.2013 15:23:16



20 dB Bandwidth Plot on Channel 39

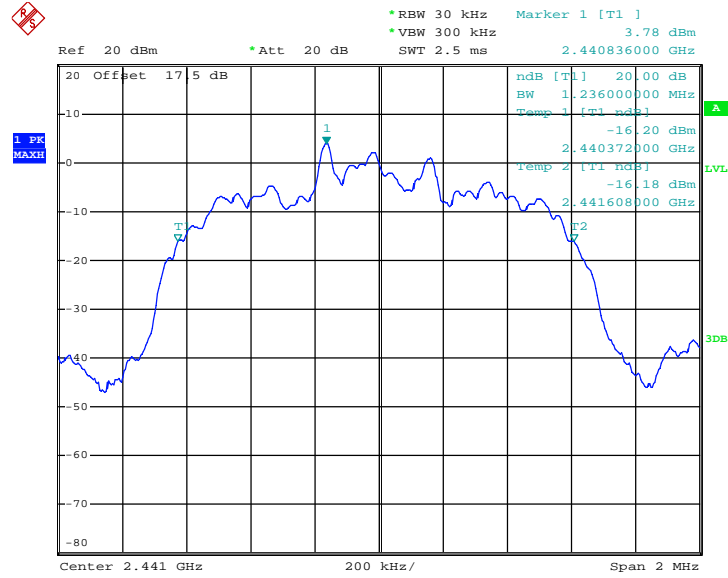

Date: 16.MAY.2013 15:24:47

20 dB Bandwidth Plot on Channel 78

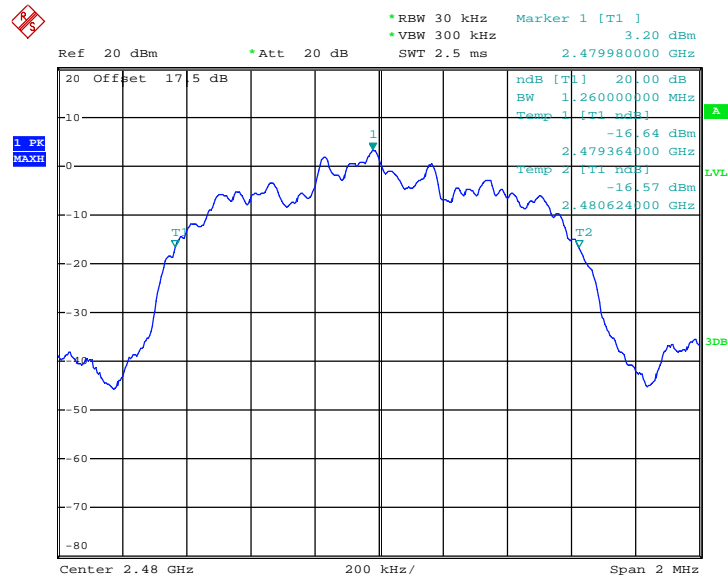

Date: 16.MAY.2013 15:31:57



Test Mode :	3Mbps	Temperature :	24~26°C
Test Engineer :	Fly Chen	Relative Humidity :	50~53%

Channel	Frequency (MHz)	20dB Bandwidth (MHz)
00	2402	1.228
39	2441	1.228
78	2480	1.228

20 dB Bandwidth Plot on Channel 00

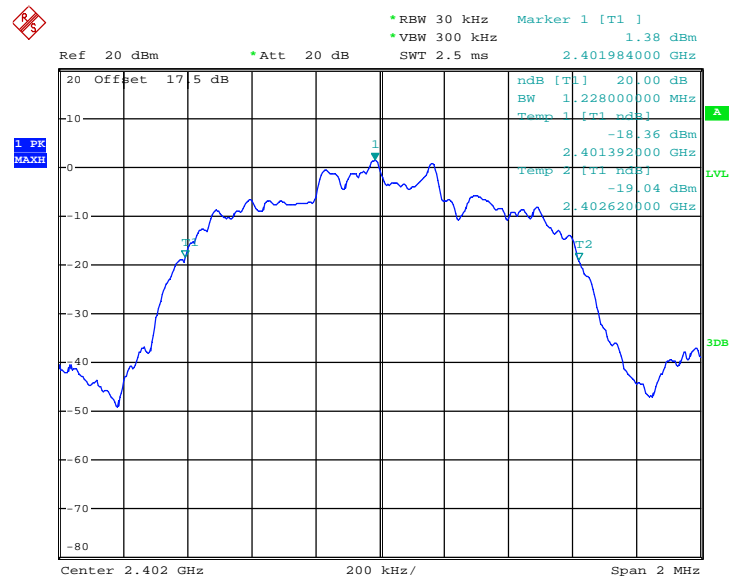

Date: 16.MAY.2013 15:23:50



20 dB Bandwidth Plot on Channel 39

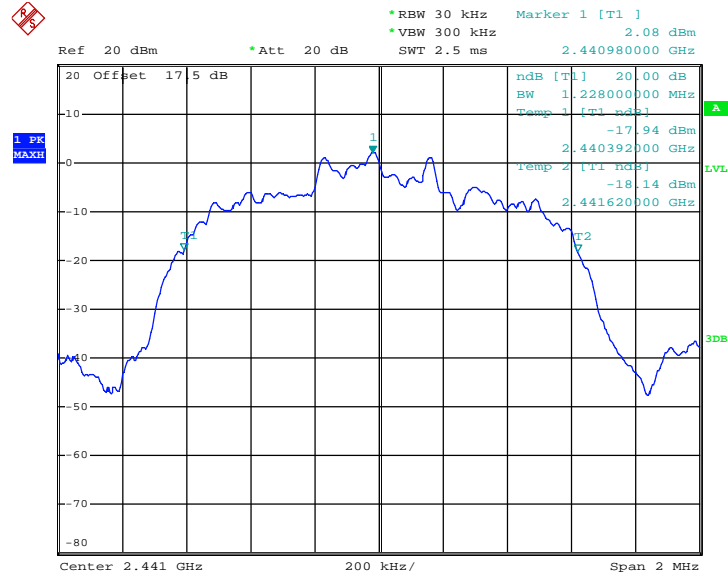

Date: 16.MAY.2013 15:24:19

20 dB Bandwidth Plot on Channel 78

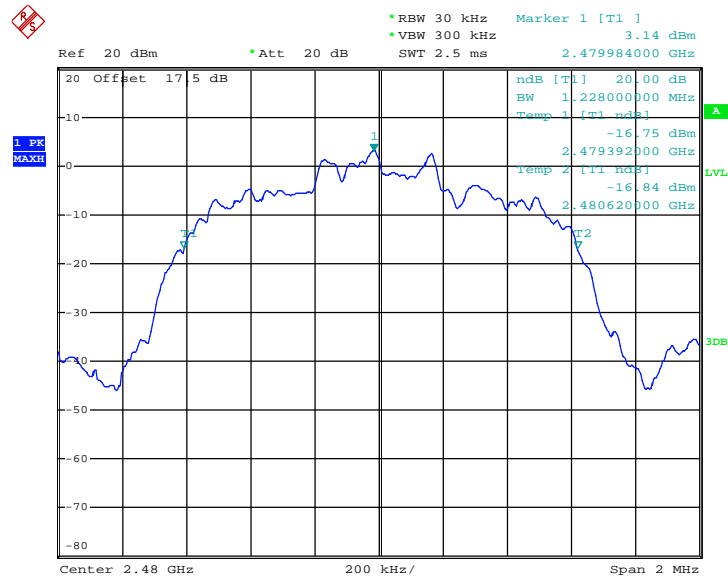

Date: 16.MAY.2013 15:32:19

## 3.5 Peak Output Power Measurement

### 3.5.1 Limit of Peak Output Power

Section 15.247 (b) The maximum peak conducted output power of the intentional radiator shall not exceed the following: (1) For frequency hopping systems operating in the 2400-2483.5 MHz band employing at least 75 non-overlapping hopping channels, and all frequency hopping systems in the 5725-5850 MHz band: 1 watt. For all other frequency hopping systems in the 2400-2483.5 MHz band 0.125 watts. The power limit for 1Mbps is 1watt, and for 2Mbps, and 3Mbps are 0.125 watts.

### 3.5.2 Measuring Instruments

See list of measuring instruments of this test report.

### 3.5.3 Test Procedures

1. The testing follows FCC Public Notice DA 00-705 Measurement Guidelines.
2. The RF output of EUT was connected to the power meter by RF cable and attenuator. The path loss was compensated to the results for each measurement.
3. Set to the maximum power setting and enable the EUT transmit continuously.
4. Measure the conducted output power with cable loss and record the results in the test report.
5. Measure and record the results in the test report.

### 3.5.4 Test Setup

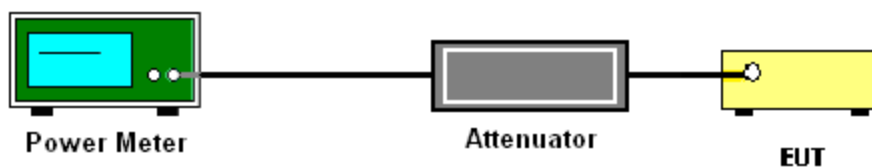



3.5.5 Test Result of Peak Output Power

Test Mode :	1Mbps	Temperature :	24~26°C
Test Engineer :	Fly Chen	Relative Humidity :	50~53%

Channel	Frequency (MHz)	RF Power (dBm)		
		GFSK	Max. Limits (dBm)	Pass/Fail
		1 Mbps		
00	2402	2.24	30.00	Pass
39	2441	4.10	30.00	Pass
78	2480	4.21	30.00	Pass



## 3.6 Conducted Band Edges Measurement

### 3.6.1 Limit of Band Edges

In any 100 KHz bandwidth outside the intentional radiation frequency band, the radio frequency power shall be at least 20 dB below the highest level of the radiated power. In addition, radiated emissions which fall in the restricted bands must also comply with the radiated emission limits.

### 3.6.2 Measuring Instruments

See list of measuring instruments of this test report.

### 3.6.3 Test Procedures

1. The testing follows the guidelines in Band-edge Compliance of RF Conducted Emissions of FCC Public Notice DA 00-705 Measurement Guidelines.
2. Set to the maximum power setting and enable the EUT transmit continuously.
3. Set RBW = 300KHz ( $\geq 1\%$  span=30MHz ), VBW = 300KHz ( $\geq$  RBW). Band edge emissions must be at least 20 dB down from the highest emission level within the authorized band as measured with a 300KHz RBW. The attenuation shall be 30 dB instead of 20 dB when RMS conducted output power procedure is used.
4. Enable hopping function of the EUT and then repeat step 2. and 3.
5. Measure and record the results in the test report.

### 3.6.4 Test Setup

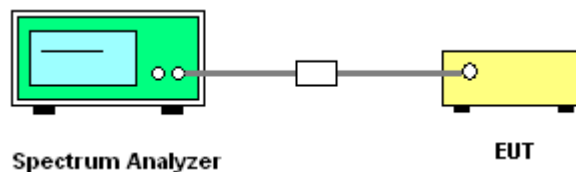



### 3.6.6 Test Result of Conducted Band Edges

Test Mode :	1Mbps	Temperature :	24~26°C
Test Channel :	00 and 78	Relative Humidity :	50~53%
		Test Engineer :	Fly Chen

#### Low Band Edge Plot on Channel 00

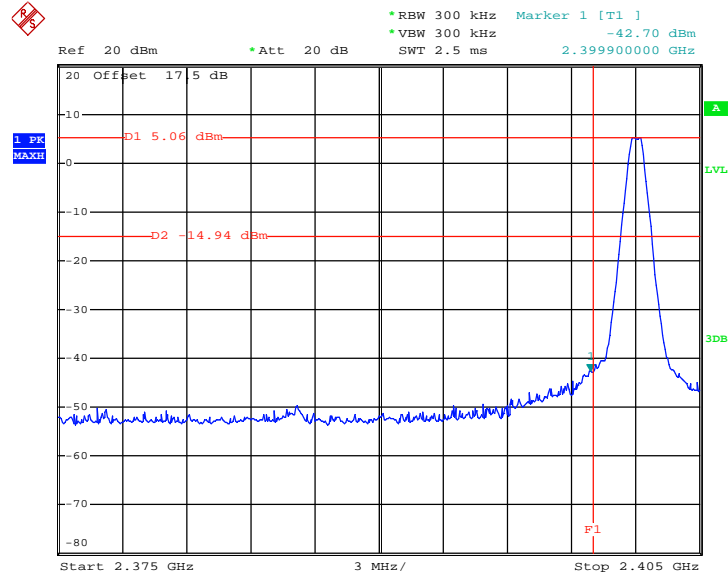

Date: 16.MAY.2013 16:18:54

#### High Band Edge Plot on Channel 78

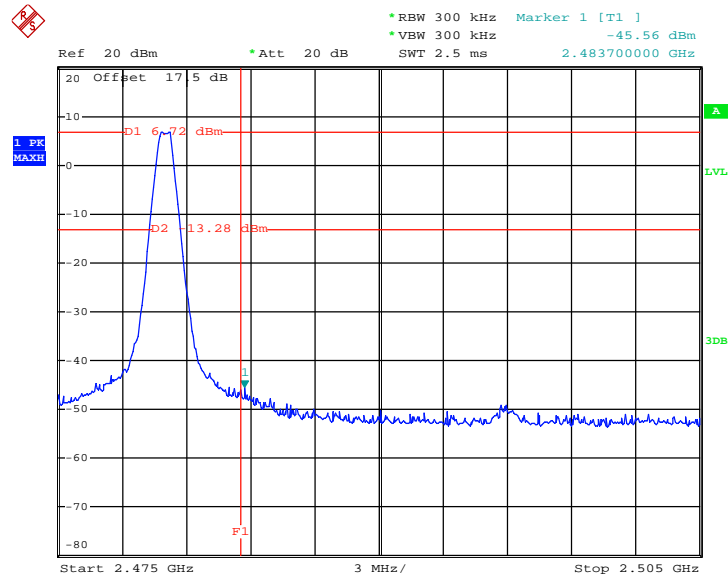

Date: 16.MAY.2013 16:18:08



Test Mode :	2Mbps	Temperature :	24~26°C
Test Channel :	00 and 78	Relative Humidity :	50~53%
		Test Engineer :	Fly Chen

Low Band Edge Plot on Channel 00

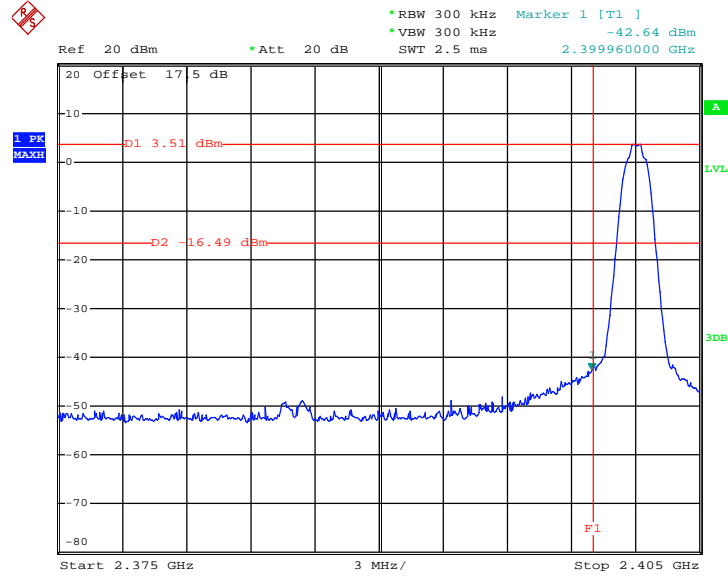

Date: 16.MAY.2013 16:16:57

High Band Edge Plot on Channel 78

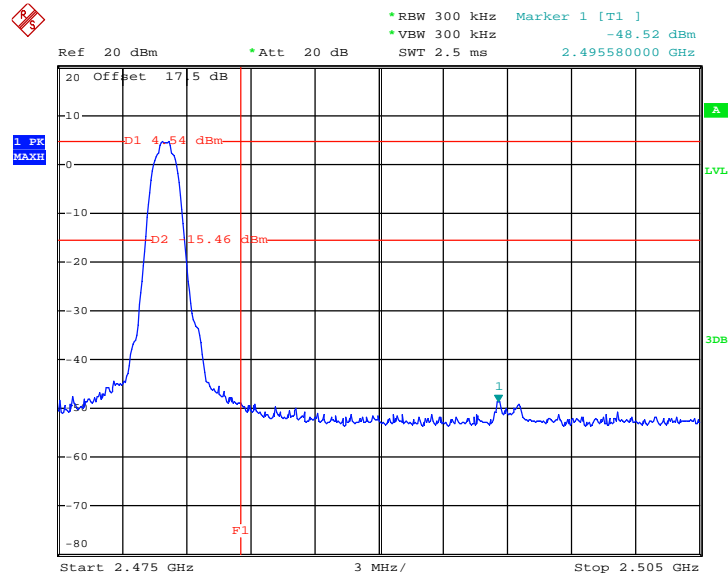

Date: 18.MAY.2013 16:02:10



Test Mode :	3Mbps	Temperature :	24~26°C
Test Channel :	00 and 78	Relative Humidity :	50~53%
		Test Engineer :	Fly Chen

Low Band Edge Plot on Channel 00

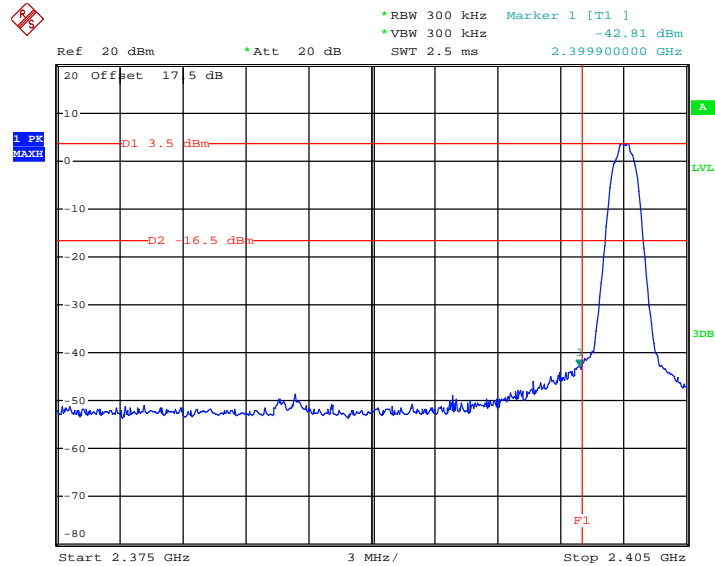

Date: 16.MAY.2013 16:14:14

High Band Edge Plot on Channel 78

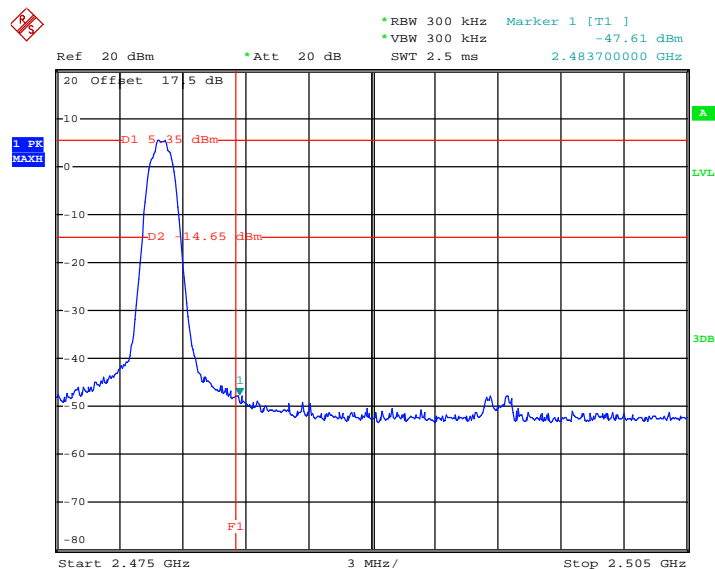

Date: 16.MAY.2013 16:13:09

### 3.6.7 Test Result of Conducted Hopping Mode Band Edges

Test Mode :	1Mbps	Temperature :	24~26°C
Test Engineer :	Fly Chen	Relative Humidity :	50~53%

Hopping Mode Low Band Edge Plot on Channel 00

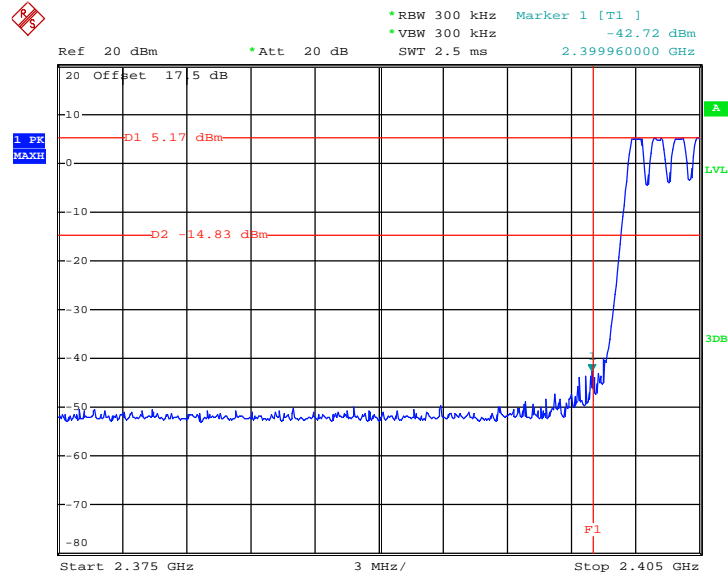

Date: 16.MAY.2013 16:23:40

Hopping Mode High Band Edge Plot on Channel 78

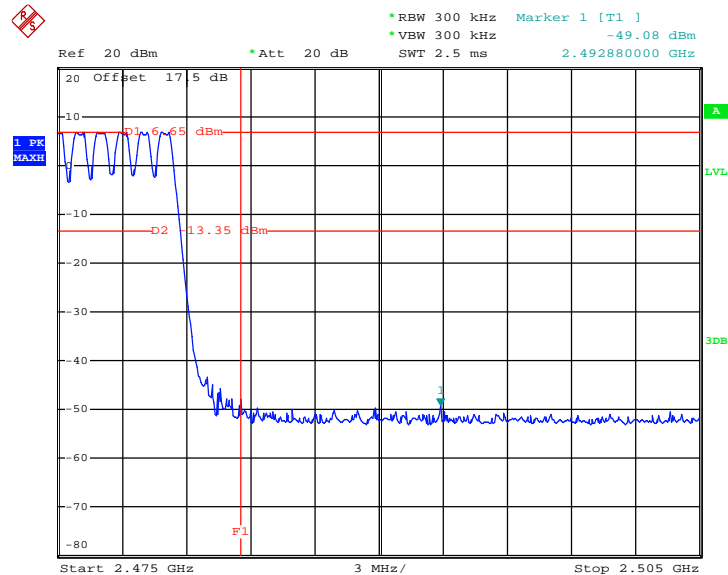

Date: 16.MAY.2013 16:21:41



Test Mode :	2Mbps	Temperature :	24~26°C
Test Engineer :	Fly Chen	Relative Humidity :	50~53%

Hopping Mode Low Band Edge Plot on Channel 00

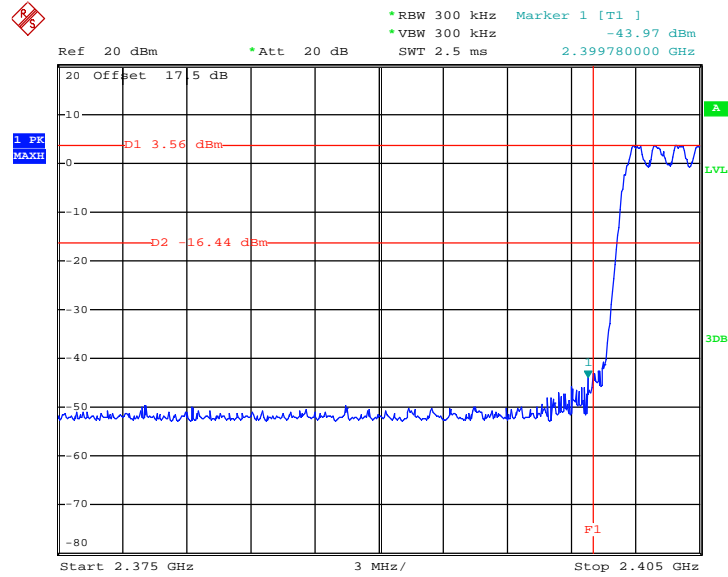

Date: 16.MAY.2013 16:28:18

Hopping Mode High Band Edge Plot on Channel 78

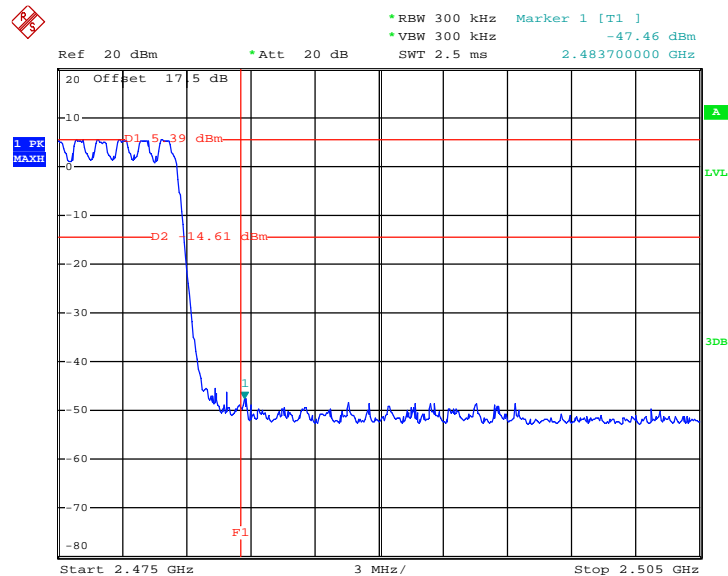

Date: 16.MAY.2013 16:26:23



Test Mode :	3Mbps	Temperature :	24~26°C
Test Engineer :	Fly Chen	Relative Humidity :	50~53%

Hopping Mode Low Band Edge Plot on Channel 00

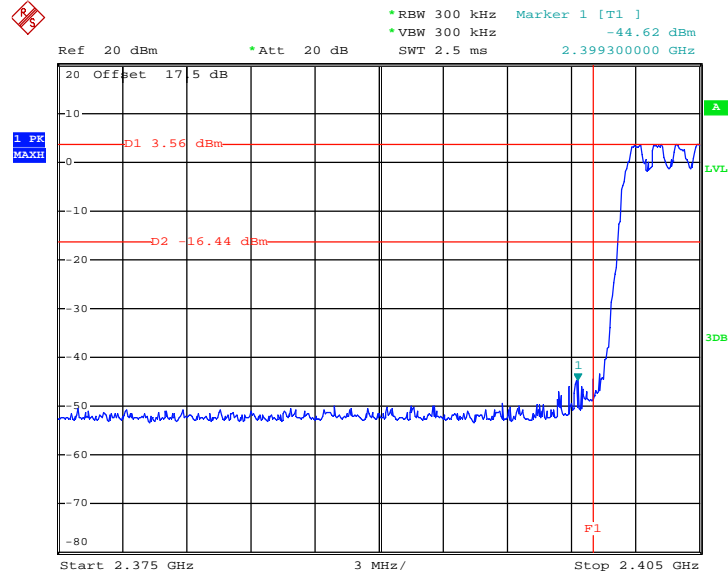

Date: 16.MAY.2013 16:31:12

Hopping Mode High Band Edge Plot on Channel 78

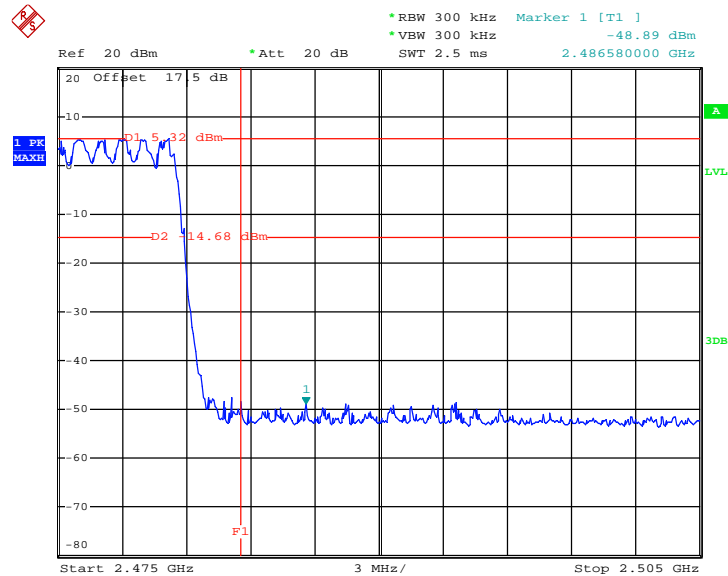

Date: 16.MAY.2013 16:29:49

## 3.7 Conducted Spurious Emission Measurement

### 3.7.1 Limit of Spurious Emission Measurement

In any 100 KHz bandwidth outside the intentional radiation frequency band, the radio frequency power shall be at least 20 dB below the highest level of the radiated power. In addition, radiated emissions which fall in the restricted bands must also comply with the radiated emission limits.

### 3.7.2 Measuring Instruments

See list of measuring instruments of this test report.

### 3.7.3 Test Procedure

1. The testing follows the guidelines in Spurious RF Conducted Emissions of FCC Public Notice DA 00-705 Measurement Guidelines
2. The RF output of EUT was connected to the spectrum analyzer by RF cable and attenuator. The path loss was compensated to the results for each measurement.
3. Set to the maximum power setting and enable the EUT transmit continuously.
4. Set RBW = 100 KHz, VBW = 300KHz, scan up through 10th harmonic. All harmonics / spurs must be at least 20 dB down from the highest emission level within the authorized band as measured with a 100 KHz RBW.
5. Measure and record the results in the test report.

### 3.7.4 Test Setup

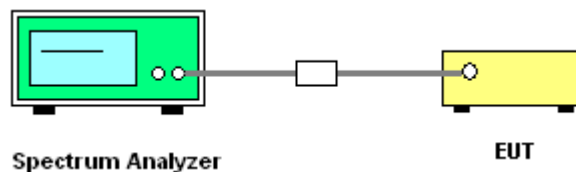



### 3.7.5 Test Results

Test Mode :	1Mbps	Temperature :	24~26°C
Test Channel :	00	Relative Humidity :	50~53%
		Test Engineer :	Fly Chen

#### Conducted Spurious Emission Plot between 30MHz ~ 3 GHz

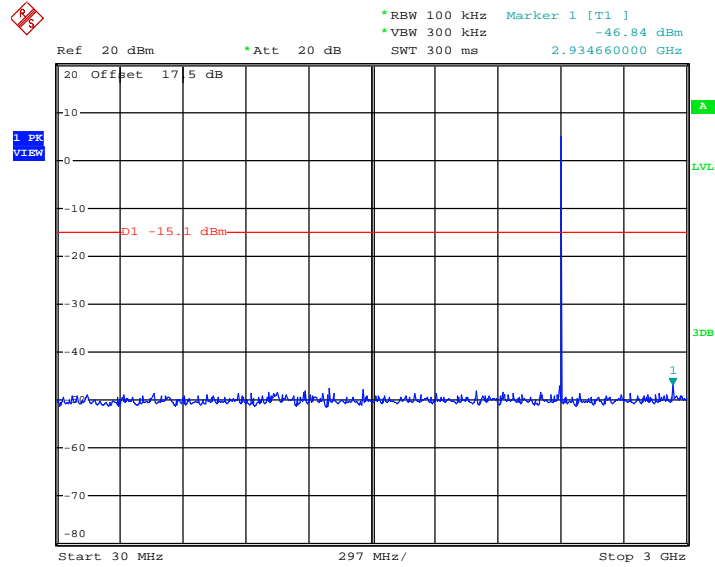

Date: 16.MAY.2013 17:10:26

#### Conducted Spurious Emission Plot between 2 GHz ~ 25 GHz

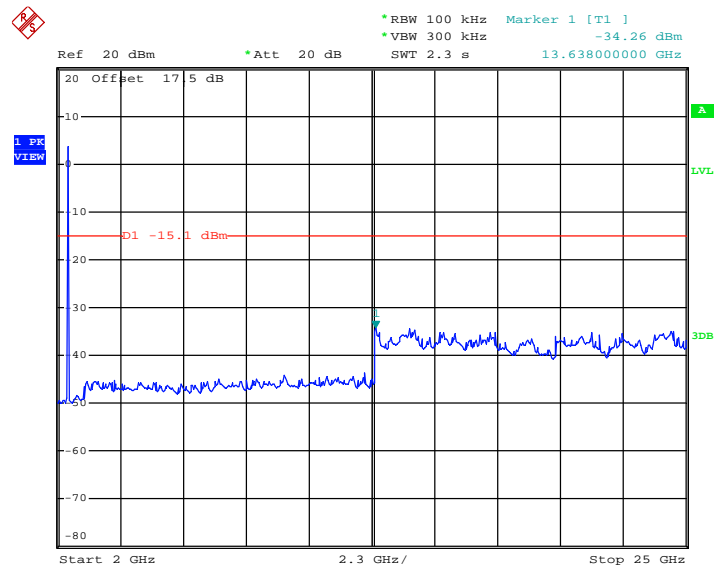

Date: 16.MAY.2013 17:11:01



Test Mode :	1Mbps	Temperature :	24~26°C
Test Channel :	39	Relative Humidity :	50~53%
		Test Engineer :	Fly Chen

Conducted Spurious Emission Plot between 30MHz ~ 3 GHz

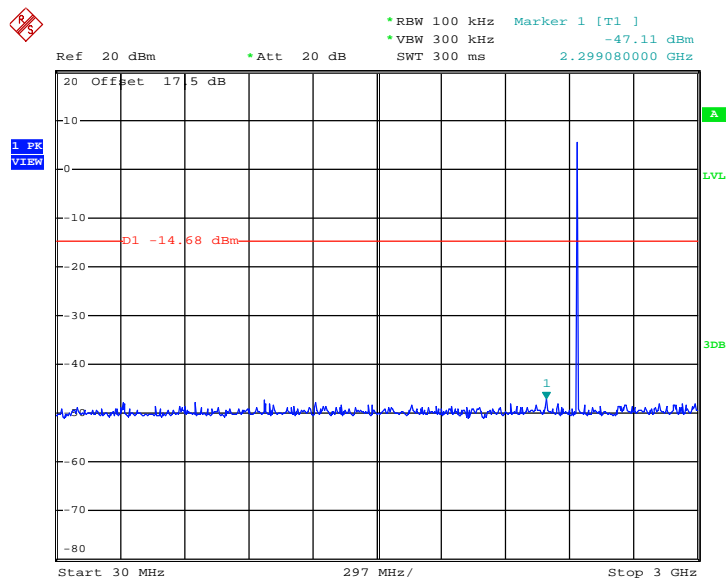

Date: 16.MAY.2013 17:11:50

Conducted Spurious Emission Plot between 2 GHz ~ 25 GHz

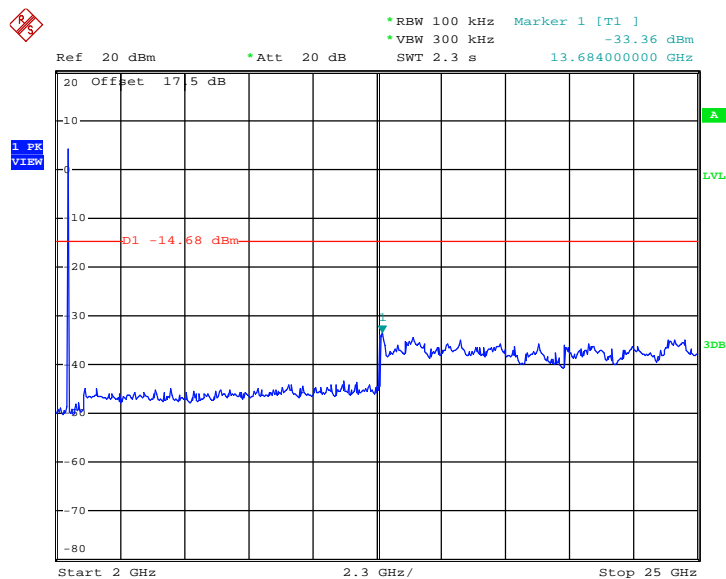

Date: 16.MAY.2013 17:12:35



Test Mode :	1Mbps	Temperature :	24~26°C
Test Channel :	78	Relative Humidity :	50~53%
		Test Engineer :	Fly Chen

Conducted Spurious Emission Plot between 30MHz ~ 3 GHz

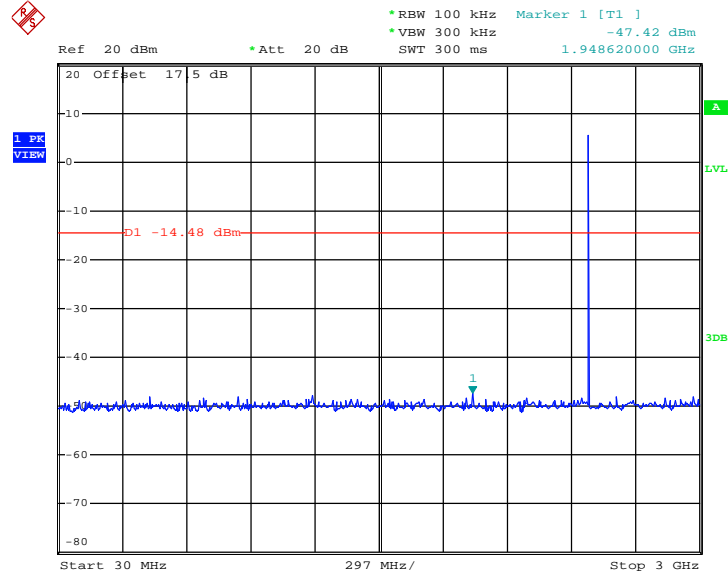

Date: 16.MAY.2013 17:13:27

Conducted Spurious Emission Plot between 2 GHz ~ 25 GHz

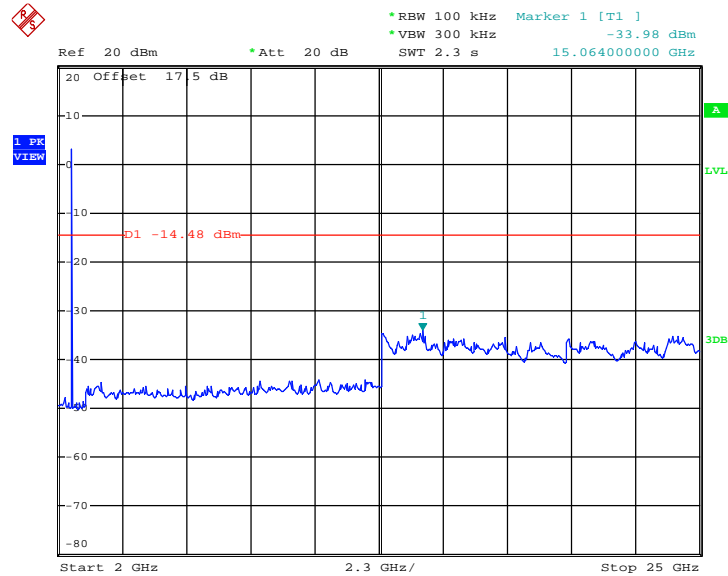

Date: 16.MAY.2013 17:13:59

## 3.8 Radiated Band Edges and Spurious Emission Measurement

### 3.8.1 Limit of Radiated Band Edges and Spurious Emission

In any 100 KHz bandwidth outside the intentional radiator frequency band, all harmonics/spurious must be at least 20 dB below the highest emission level within the authorized band. In addition, radiated emissions which fall in the restricted bands must also comply with the FCC section 15.209 limits as below.

Frequency (MHz)	Field Strength (microvolts/meter)	Measurement Distance (meters)
0.009 – 0.490	2400/F(KHz)	300
0.490 – 1.705	24000/F(KHz)	30
1.705 – 30.0	30	30
30 – 88	100	3
88 – 216	150	3
216 - 960	200	3
Above 960	500	3

### 3.8.2 Measuring Instruments

See list of measuring instruments of this test report.

### 3.8.3 Test Procedures

1. The testing follows the guidelines in Spurious Radiated Emissions of FCC Public Notice DA 00-705 Measurement Guidelines and fulfills ANSI C63.4-2003 and the guidelines in ANSI C63.10-2009 test site requirement.
2. The EUT was placed on a turntable with 0.8 meter above ground.
3. The EUT was set 3 meters from the interference receiving antenna, which was mounted on the top of a variable height antenna tower.
4. For each suspected emission, the EUT was arranged to its worst case and then tune the Antenna tower (from 1 m to 4 m) and turntable (from 0 degree to 360 degrees) to find the maximum reading. A pre-amp and a high pass filter are used for the test in order to get better signal level to comply with the guidelines.
5. Set to the maximum power setting and enable the EUT transmit continuously.
6. For measurement below 1GHz, If the emission level of the EUT measured by the peak detector is 3 dB lower than the applicable limit, the peak emission level will be reported. Otherwise, the emission measurement will be repeated using the quasi-peak detector and reported
7. Use the following spectrum analyzer settings:
  - (1) Span shall wide enough to fully capture the emission being measured;
  - (2) Set RBW=100 KHz for  $f < 1$  GHz, RBW=1MHz for  $f > 1$ GHz ; VBW  $\geq$  RBW; Sweep = auto; Detector function = peak; Trace = max hold for peak
  - (3) For average measurement: use duty cycle correction factor method per 15.35(c).  
Duty cycle = On time/100 milliseconds  
On time =  $N_1 * L_1 + N_2 * L_2 + \dots + N_{n-1} * L_{n-1} + N_n * L_n$   
Where  $N_1$  is number of type 1 pulses,  $L_1$  is length of type 1 pulses, etc.  
Average Level = Peak Level +  $20 * \log(\text{Duty cycle})$
8. Corrected Reading: Antenna Factor + Cable Loss + Read Level - Preamp Factor = Level

Note: The average levels were calculated from the peak level corrected with duty cycle correction factor (24.79dB) derived from  $20 \log(\text{dwell time}/100\text{ms})$ .

### 3.8.4 Test Setup

For radiated emissions below 30MHz

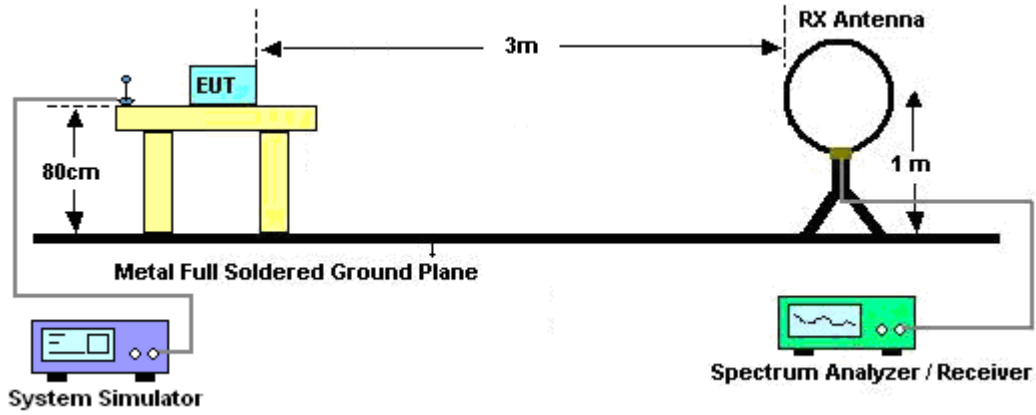

For radiated emissions from 30MHz to 1GHz

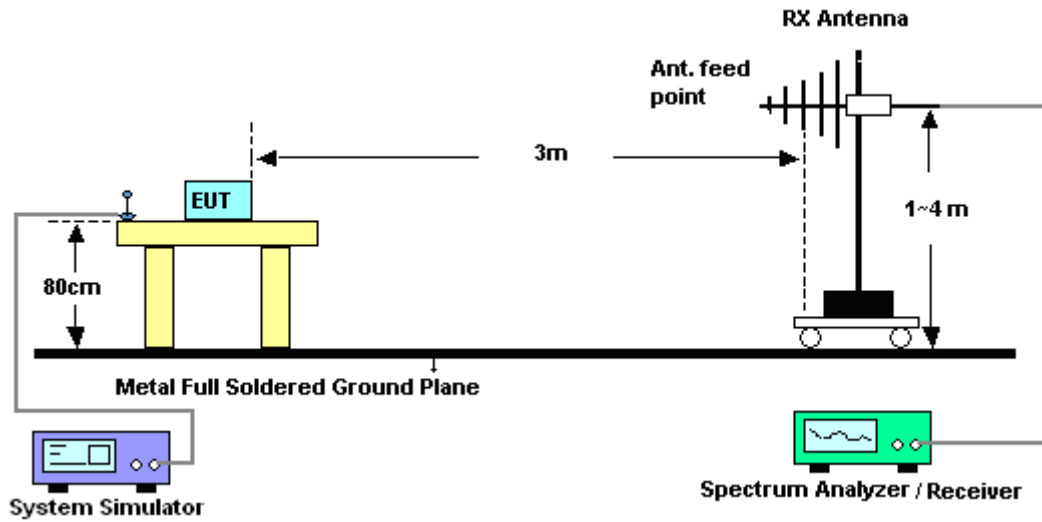

For radiated emissions above 1GHz

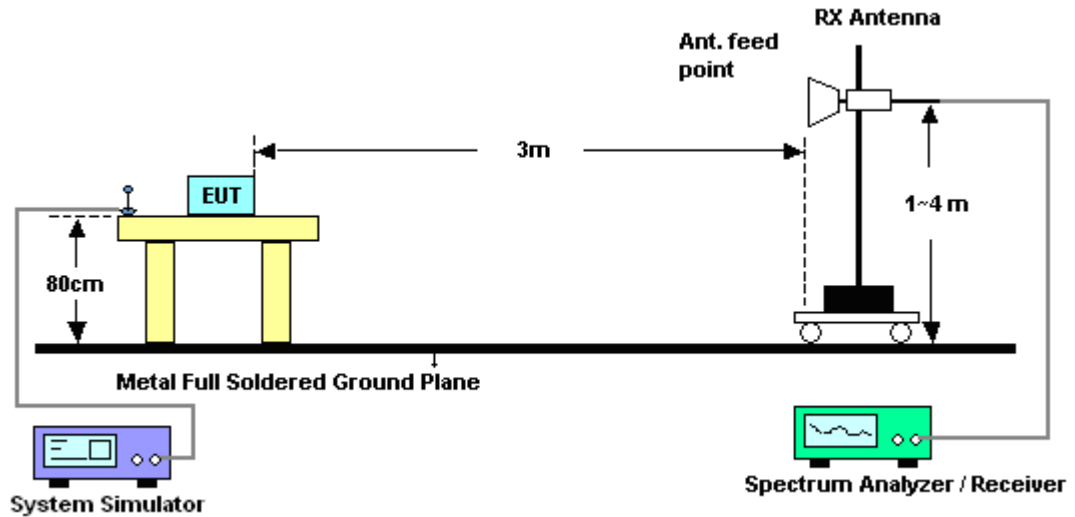

### 3.8.5 Test Results of Radiated Spurious Emission (9 KHz ~ 30 MHz)

The low frequency, which started from 9 KHz to 30MHz, was pre-scanned and the result which was 20dB lower than the limit line per 15.31(o) was not reported.

### 3.8.6 Duty cycle correction factor for average measurement

DH5 on time/100ms (One Pulse) Plot on Channel 39

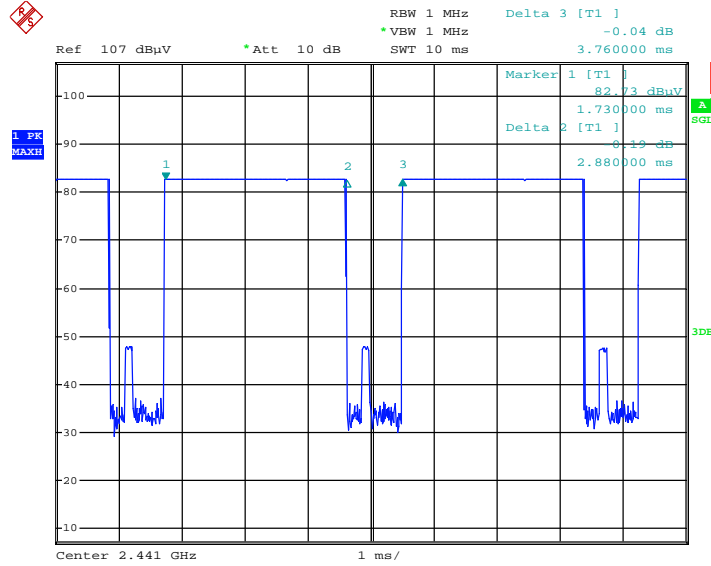

Date: 28.MAY.2013 00:10:30

DH5 on time/100ms (Count Pulses) Plot on Channel 39

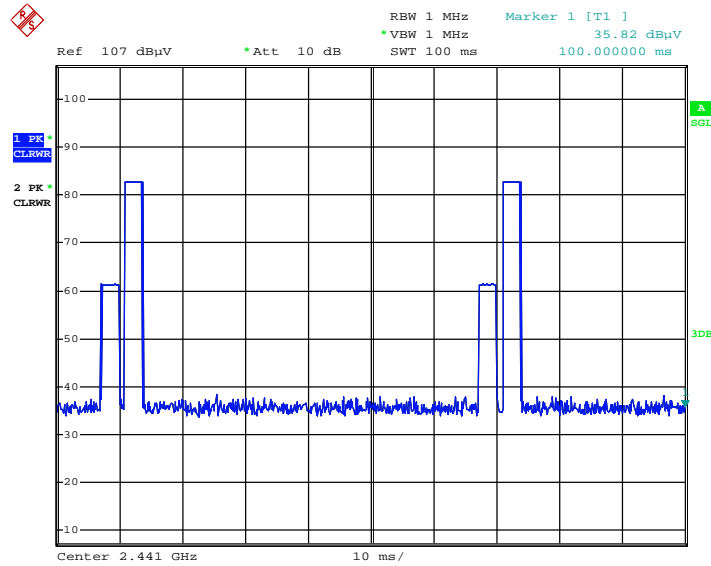

Date: 28.MAY.2013 00:01:13

**Note:**

1. Duty cycle = on time/100 milliseconds =  $2 * 2.88 / 100 = 5.76 \%$
2. Duty cycle correction factor =  $20 * \log(\text{Duty cycle}) = -24.79 \text{ dB}$
3. DH5 has the highest duty cycle and is reported.





3.8.7 Test Result of Radiated Band Edges

Test Mode :	1Mbps	Temperature :	24~25°C
Test Channel :	00	Relative Humidity :	49~50%
		Test Engineer :	Robin Luo

ANTENNA POLARITY : HORIZONTAL										
Frequency ( MHz )	Level ( dBμV/m )	Over Limit ( dB )	Limit Line ( dBμV/m )	Read Level ( dBμV )	Antenna Factor ( dB )	Cable Loss ( dB )	Preamp Factor ( dB )	Ant Pos ( cm )	Table Pos ( deg )	Remark
2376.78	45.27	-28.73	74	38.52	32.12	4.42	29.79	124	67	Peak
2376.78	20.48	-33.52	54	-	-	-	-	-	-	Average

ANTENNA POLARITY : VERTICAL										
Frequency ( MHz )	Level ( dBμV/m )	Over Limit ( dB )	Limit Line ( dBμV/m )	Read Level ( dBμV )	Antenna Factor ( dB )	Cable Loss ( dB )	Preamp Factor ( dB )	Ant Pos ( cm )	Table Pos ( deg )	Remark
2316.84	45.82	-28.18	74	39.26	32.02	4.34	29.8	152	72	Peak
2316.84	21.03	-32.97	54	-	-	-	-	-	-	Average

**Note:** The average levels were calculated from the peak level corrected with duty cycle correction factor (24.79dB) derived from 20log (dwell time/100ms).

For example: Average level = 45.27dBuV/m – 24.79 (dB) = 20.48dBuV/m.

Test Mode :	1Mbps	Temperature :	24~25°C
Test Channel :	78	Relative Humidity :	49~50%
		Test Engineer :	Robin Luo

ANTENNA POLARITY : HORIZONTAL										
Frequency ( MHz )	Level ( dBμV/m )	Over Limit ( dB )	Limit Line ( dBμV/m )	Read Level ( dBμV )	Antenna Factor ( dB )	Cable Loss ( dB )	Preamp Factor ( dB )	Ant Pos ( cm )	Table Pos ( deg )	Remark
2483.5	50.04	-23.96	74	43.06	32.27	4.47	29.76	176	127	Peak
2483.5	25.25	-28.75	54	-	-	-	-	-	-	Average

ANTENNA POLARITY : VERTICAL										
Frequency ( MHz )	Level ( dBμV/m )	Over Limit ( dB )	Limit Line ( dBμV/m )	Read Level ( dBμV )	Antenna Factor ( dB )	Cable Loss ( dB )	Preamp Factor ( dB )	Ant Pos ( cm )	Table Pos ( deg )	Remark
2483.5	50.85	-23.15	74	43.87	32.27	4.47	29.76	100	128	Peak
2483.5	26.06	-27.94	54	-	-	-	-	-	-	Average

### 3.8.8 Test Result of Radiated Spurious Emission (30 MHz ~ 10<sup>th</sup> Harmonic)

**Note:** Below 1GHz for radiated emission measurement, pre-scanned all test modes and only choose the worst case mode was recorded in the report.

<b>Test Mode :</b>	1Mbps	<b>Temperature :</b>	24~25°C
<b>Test Channel :</b>	00	<b>Relative Humidity :</b>	49~50%
<b>Test Engineer :</b>	Robin Luo	<b>Polarization :</b>	Horizontal
<b>Remark :</b>	1. 2402 MHz is fundamental signal which can be ignored. 2. 2399MHz and 7206MHz are not within a restricted band, and their limit line is 20dB below the highest emission level. For example, 89.76dBuV/m - 20dB = 69.76dBuV/m. 3. Average measurement was not performed if peak level went lower than the average limit.		

Frequency ( MHz )	Level ( dBμV/m )	Over Limit ( dB )	Limit Line ( dBμV/m )	Read Level ( dBμV )	Antenna Factor ( dB )	Cable Loss ( dB )	Preamp Factor ( dB )	Ant Pos ( cm )	Table Pos ( deg )	Remark
32.91	18.99	-21.01	40	35.13	13.5	0.93	30.57	-	-	Peak
92.08	22.51	-20.99	43.5	41.82	10.2	1.14	30.65	-	-	Peak
106.63	24.98	-18.52	43.5	42.51	11.93	1.18	30.64	-	-	Peak
227.88	20.96	-25.04	46	39.42	10.2	1.58	30.24	-	-	Peak
460.68	22.48	-23.52	46	33.09	16.84	2.01	29.46	-	-	Peak
800.18	29.95	-16.05	46	35.76	20.5	2.62	28.93	200	166	Peak
2399	54.35	-15.41	69.76	47.57	32.14	4.42	29.78	113	200	Peak
2402	89.76	-	-	82.96	32.14	4.44	29.78	113	200	Peak
2402	64.97	-	-	-	-	-	-	100	54	Average
4804	45.45	-28.55	74	63.55	33.63	5.95	57.68	100	213	Peak
4804	20.66	-33.34	54	-	-	-	-	122	198	Average
7206	47	-22.76	69.76	62.25	35.27	7.47	57.99	100	23	Peak

**Note:** Other harmonics are lower than background noise.



<b>Test Mode :</b>	1Mbps	<b>Temperature :</b>	24~25°C
<b>Test Channel :</b>	00	<b>Relative Humidity :</b>	49~50%
<b>Test Engineer :</b>	Robin Luo	<b>Polarization :</b>	Vertical
<b>Remark :</b>	1. 2402 MHz is fundamental signal which can be ignored. 2. 2399MHz and 7206MHz are not within a restricted band, and their limit line is 20dB below the highest emission level. 3. Average measurement was not performed if peak level went lower than the average limit.		

Frequency ( MHz )	Level ( dBμV/m )	Over Limit ( dB )	Limit Line ( dBμV/m )	Read Level (dBμV)	Antenna Factor ( dB )	Cable Loss ( dB )	Preamp Factor ( dB )	Ant Pos ( cm )	Table Pos ( deg )	Remark
31.94	24.16	-15.84	40	40.29	13.5	0.94	30.57	128	33	Peak
40.67	20.83	-19.17	40	40.41	10.1	0.86	30.54	-	-	Peak
45.52	20.74	-19.26	40	41.69	8.7	0.87	30.52	-	-	Peak
93.05	23.69	-19.81	43.5	43	10.2	1.14	30.65	-	-	Peak
197.81	19.84	-23.66	43.5	39.59	9.15	1.44	30.34	-	-	Peak
725.49	23.83	-22.17	46	30.12	20.24	2.5	29.03	-	-	Peak
2399	53.36	-19.21	72.57	46.58	32.14	4.42	29.78	152	72	Peak
2402	92.57	-	-	85.77	32.14	4.44	29.78	152	72	Peak
2402	67.78	-	-	-	-	-	-	200	21	Average
4804	54.85	-19.15	74	44.61	33.63	5.95	29.34	100	0	Peak
4804	30.06	-23.94	54	-	-	-	-	100	0	Average
7206	51.88	-20.69	72.57	37.23	35.27	7.47	28.09	136	92	Peak

**Note:** Other harmonics are lower than background noise.



<b>Test Mode :</b>	1Mbps	<b>Temperature :</b>	24~25°C
<b>Test Channel :</b>	39	<b>Relative Humidity :</b>	49~50%
<b>Test Engineer :</b>	Robin Luo	<b>Polarization :</b>	Horizontal
<b>Remark :</b>	1. 2441 MHz is fundamental signal which can be ignored. 2. Average measurement was not performed if peak level went lower than the average limit.		

Frequency ( MHz )	Level ( dBμV/m )	Over Limit ( dB )	Limit Line ( dBμV/m )	Read Level (dBμV)	Antenna Factor ( dB )	Cable Loss ( dB )	Preamp Factor ( dB )	Ant Pos ( cm )	Table Pos ( deg )	Remark
2441	95	-	-	88.09	32.22	4.45	29.76	100	21	Peak
2441	70.21	-	-	-	-	-	-	100	21	Average
4882	45.89	-28.11	74	63.47	33.8	6.02	57.4	100	254	Peak
7323	50.82	-23.18	74	65.56	35.32	7.9	57.96	100	320	Peak

**Note:** Other harmonics are lower than background noise.

<b>Test Mode :</b>	1Mbps	<b>Temperature :</b>	24~25°C
<b>Test Channel :</b>	39	<b>Relative Humidity :</b>	49~50%
<b>Test Engineer :</b>	Robin Luo	<b>Polarization :</b>	Vertical
<b>Remark :</b>	1. 2441 MHz is fundamental signal which can be ignored. 2. Average measurement was not performed if peak level went lower than the average limit.		

Frequency ( MHz )	Level ( dBμV/m )	Over Limit ( dB )	Limit Line ( dBμV/m )	Read Level (dBμV)	Antenna Factor ( dB )	Cable Loss ( dB )	Preamp Factor ( dB )	Ant Pos ( cm )	Table Pos ( deg )	Remark
2441	91.56	-	-	84.65	32.22	4.45	29.76	100	266	Peak
2441	66.77	-	-	-	-	-	-	100	266	Average
4882	44.58	-29.42	74	62.16	33.8	6.02	57.4	200	320	Peak
7323	50.02	-23.98	74	64.76	35.32	7.9	57.96	200	32	Peak

**Note:** Other harmonics are lower than background noise.



<b>Test Mode :</b>	1Mbps	<b>Temperature :</b>	24~25°C
<b>Test Channel :</b>	78	<b>Relative Humidity :</b>	49~50%
<b>Test Engineer :</b>	Robin Luo	<b>Polarization :</b>	Horizontal
<b>Remark :</b>	1. 2480 MHz is fundamental signal which can be ignored. 2. Average measurement was not performed if peak level went lower than the average limit.		

Frequency ( MHz )	Level ( dBμV/m )	Over Limit ( dB )	Limit Line ( dBμV/m )	Read Level (dBμV)	Antenna Factor ( dB )	Cable Loss ( dB )	Preamp Factor ( dB )	Ant Pos ( cm )	Table Pos ( deg )	Remark
2480	92.5	-	-	85.52	32.27	4.47	29.76	176	127	Peak
2480	67.71	-	-	-	-	-	-	-	-	Average
4960	45.47	-28.53	74	62.38	34.01	6.13	57.05	111	124	Peak
7440	51.05	-22.95	74	65.53	35.37	8.08	57.93	200	360	Peak

**Note:** Other harmonics are lower than background noise.

<b>Test Mode :</b>	1Mbps	<b>Temperature :</b>	24~25°C
<b>Test Channel :</b>	78	<b>Relative Humidity :</b>	49~50%
<b>Test Engineer :</b>	Robin Luo	<b>Polarization :</b>	Vertical
<b>Remark :</b>	1. 2480 MHz is fundamental signal which can be ignored. 2. Average measurement was not performed if peak level went lower than the average limit.		

Frequency ( MHz )	Level ( dBμV/m )	Over Limit ( dB )	Limit Line ( dBμV/m )	Read Level (dBμV)	Antenna Factor ( dB )	Cable Loss ( dB )	Preamp Factor ( dB )	Ant Pos ( cm )	Table Pos ( deg )	Remark
2480	93.72	-	-	86.74	32.27	4.47	29.76	100	128	Peak
2480	68.93	-	-	-	-	-	-	-	-	Average
4960	44.58	-29.42	74	61.49	34.01	6.13	57.05	200	320	Peak
7440	50.02	-23.98	74	64.5	35.37	8.08	57.93	200	32	Peak

**Note:** Other harmonics are lower than background noise.

## 3.9 AC Conducted Emission Measurement

### 3.9.1 Limit of AC Conducted Emission

For equipment that is designed to be connected to the public utility (AC) power line, the radio frequency voltage that is conducted back onto the AC power line on any frequency or frequencies within the band 150 KHz to 30 MHz shall not exceed the limits in the following table.

Frequency of emission (MHz)	Conducted limit (dBuV)	
	Quasi-peak	Average
0.15-0.5	66 to 56*	56 to 46*
0.5-5	56	46
5-30	60	50

\*Decreases with the logarithm of the frequency.

### 3.9.2 Measuring Instruments

See list of measuring instruments of this test report.

### 3.9.3 Test Procedures

1. The test follows the guidelines in ANSI C63.10-2009 test site requirement.
2. The EUT was placed 0.4 meter from the conducting wall of the shielding room was kept at least 80 centimeters from any other grounded conducting surface.
3. Connect EUT to the power mains through a line impedance stabilization network (LISN).
4. All the support units are connecting to the other LISN.
5. The LISN provides 50 ohm coupling impedance for the measuring instrument.
6. The FCC states that a 50 ohm, 50 microhenry LISN should be used.
7. Both sides of AC line were checked for maximum conducted interference.
8. The frequency range from 150 KHz to 30 MHz was searched.
9. Set the test-receiver system to Peak Detect Function and specified bandwidth with Maximum Hold Mode.

### 3.9.4 Test Setup

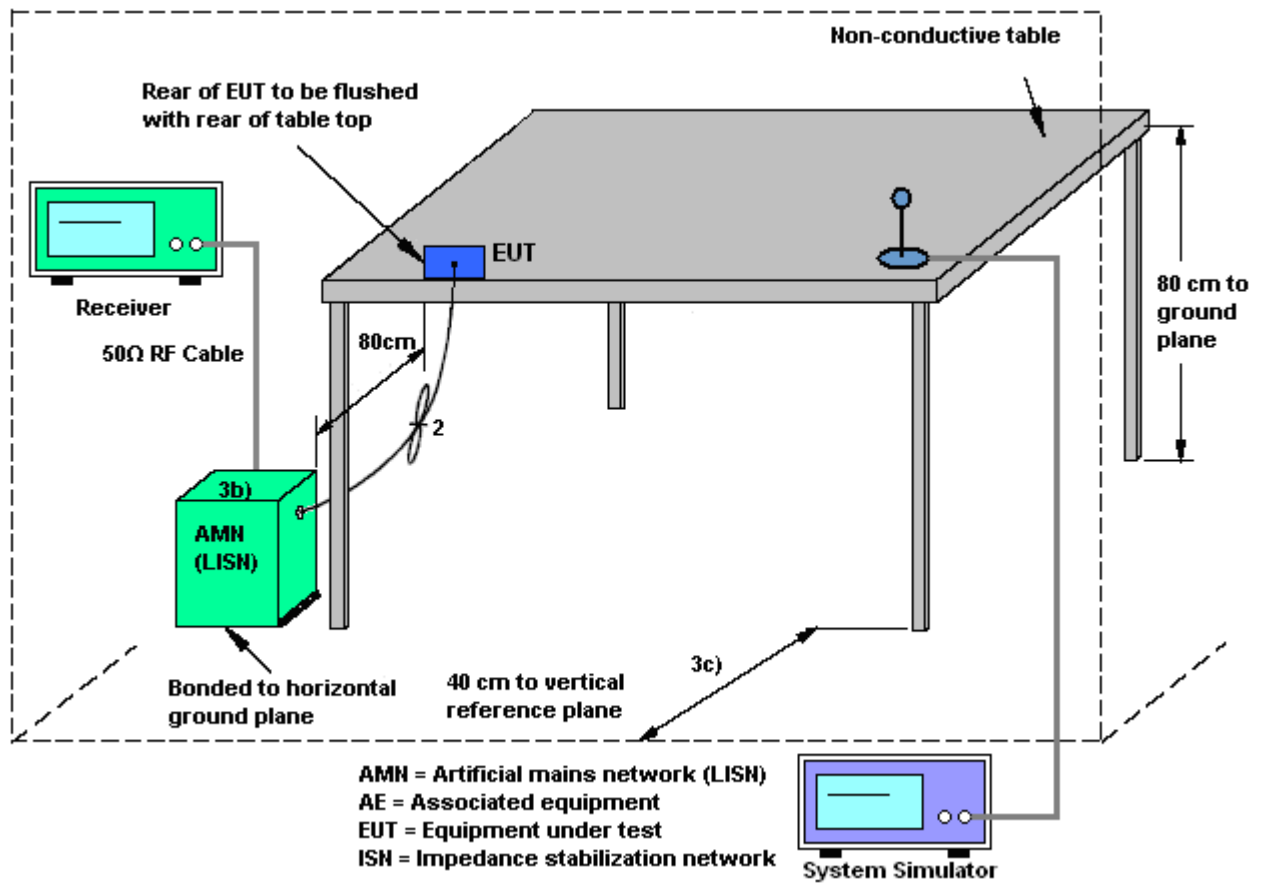

3.9.5 Test Result of AC Conducted Emission

Test Mode :	Mode 1	Temperature :	24~25°C
Test Engineer :	Leo Liao	Relative Humidity :	49~50%
Test Voltage :	120Vac / 60Hz	Phase :	Line
Function Type :	GSM850 Idle + Bluetooth Link + WLAN Link + USB Cable (Charging from Adapter) + Earphone		
Remark :	All emissions not reported here are more than 10 dB below the prescribed limit.		

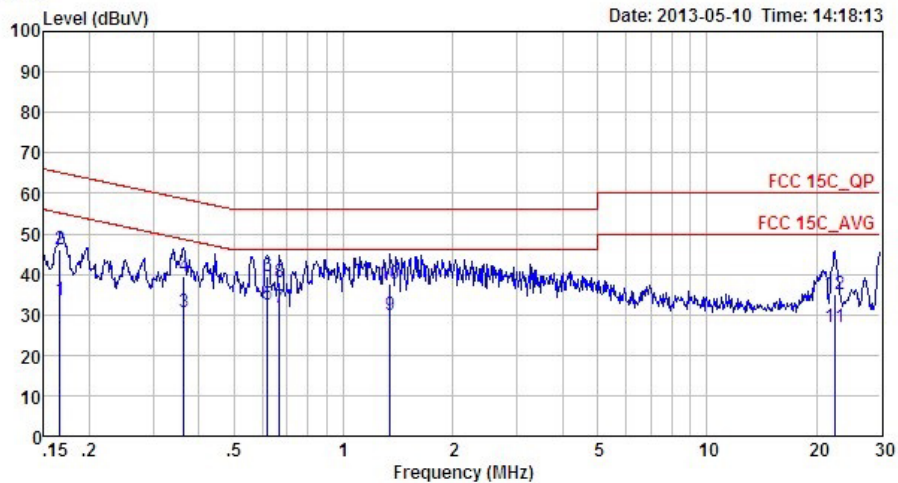

Site : C001-SZ  
 Condition: FCC 15C\_QP LISN\_L\_2000601 LINE  
 Project : (FR) 350321  
 Mode : Mode 1

	Freq	Level	Over Limit	Limit Line	Read Level	LISN Factor	Cable Loss	Remark
	MHz	dBuV	dB	dBuV	dBuV	dB	dB	
1	0.17	33.48	-21.68	55.16	23.40	0.03	10.05	Average
2	0.17	46.28	-18.88	65.16	36.20	0.03	10.05	QP
3	0.36	30.49	-18.16	48.65	20.40	0.02	10.07	Average
4	0.36	39.59	-19.06	58.65	29.50	0.02	10.07	QP
5 *	0.62	32.32	-13.68	46.00	22.20	0.02	10.10	Average
6	0.62	39.62	-16.38	56.00	29.50	0.02	10.10	QP
7	0.67	31.72	-14.28	46.00	21.60	0.02	10.10	Average
8	0.67	38.12	-17.88	56.00	28.00	0.02	10.10	QP
9	1.34	29.95	-16.05	46.00	19.80	0.03	10.12	Average
10	1.34	37.75	-18.25	56.00	27.60	0.03	10.12	QP
11	22.42	26.89	-23.11	50.00	16.00	0.43	10.46	Average
12	22.42	35.09	-24.91	60.00	24.20	0.43	10.46	QP





Test Mode :	Mode 1	Temperature :	24~25°C
Test Engineer :	Leo Liao	Relative Humidity :	49~50%
Test Voltage :	120Vac / 60Hz	Phase :	Neutral
Function Type :	GSM850 Idle + Bluetooth Link + WLAN Link + USB Cable (Charging from Adapter) + Earphone		
Remark :	All emissions not reported here are more than 10 dB below the prescribed limit.		

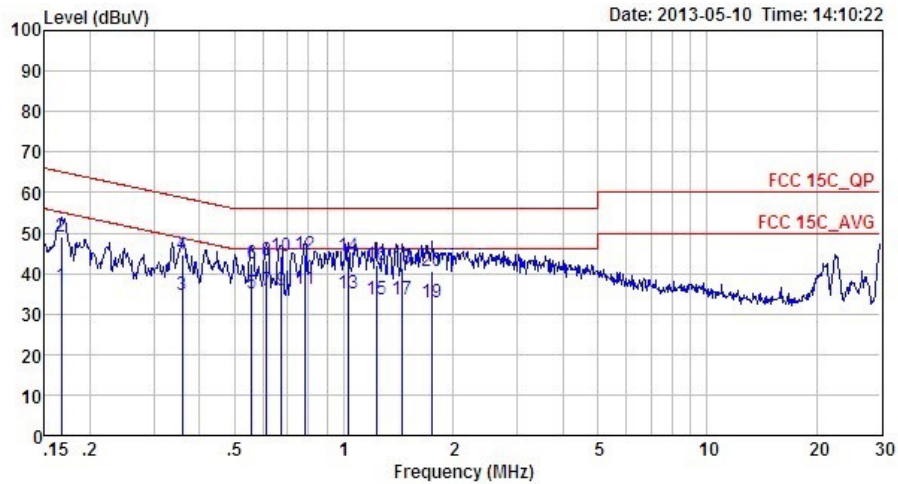

Site : CO01-SZ  
 Condition: FCC 15C\_QP LISN\_N\_2000601 NEUTRAL  
 Project : (FR) 350321  
 Mode : Mode 1

	Freq	Level	Over Limit	Limit Line	Read Level	LISN Factor	Cable Loss	Remark
	MHz	dBuV	dB	dBuV	dBuV	dB	dB	
1	0.17	37.08	-18.04	55.12	27.01	0.02	10.05	Average
2	0.17	48.98	-16.14	65.12	38.91	0.02	10.05	QP
3	0.36	34.79	-13.95	48.74	24.70	0.02	10.07	Average
4	0.36	44.49	-14.25	58.74	34.40	0.02	10.07	QP
5	0.56	35.21	-10.79	46.00	25.10	0.02	10.09	Average
6	0.56	42.31	-13.69	56.00	32.20	0.02	10.09	QP
7	0.61	35.91	-10.09	46.00	25.79	0.02	10.10	Average
8	0.61	43.11	-12.89	56.00	32.99	0.02	10.10	QP
9	0.67	35.92	-10.08	46.00	25.80	0.02	10.10	Average
10	0.67	44.42	-11.58	56.00	34.30	0.02	10.10	QP
11 *	0.78	36.32	-9.68	46.00	26.20	0.02	10.10	Average
12	0.78	44.82	-11.18	56.00	34.70	0.02	10.10	QP
13	1.03	34.94	-11.06	46.00	24.81	0.02	10.11	Average
14	1.03	44.14	-11.86	56.00	34.01	0.02	10.11	QP
15	1.23	33.65	-12.35	46.00	23.51	0.02	10.12	Average
16	1.23	42.05	-13.95	56.00	31.91	0.02	10.12	QP
17	1.45	33.45	-12.55	46.00	23.29	0.03	10.13	Average
18	1.45	41.25	-14.75	56.00	31.09	0.03	10.13	QP
19	1.75	32.97	-13.03	46.00	22.80	0.03	10.14	Average
20	1.75	40.77	-15.23	56.00	30.60	0.03	10.14	QP



## **3.10 Antenna Requirements**

### **3.10.1 Standard Applicable**

If directional gain of transmitting antennas is greater than 6dBi, the power shall be reduced by the same level in dB comparing to gain minus 6dBi. The use of a permanently attached antenna or of an antenna that uses a unique coupling to the intentional radiator shall be considered sufficient to comply with the FCC rule.

### **3.10.2 Antenna Connected Construction**

Non-standard connector used.

### **3.10.3 Antenna Gain**

The antenna peak gain of EUT is less than 6 dBi. Therefore, it is not necessary to reduce maximum peak output power limit.



## 4 List of Measuring Equipment

Instrument	Manufacturer	Model No.	Serial No.	Characteristics	Calibration Date	Test Date	Due Date	Remark
Spectrum Analyzer	R&S	FSP30	101400	9kHz~30GHz	Jun. 01, 2012	May 08, 2013~ May 18, 2013	May 31, 2013	Conducted (TH01-SZ)
Power meter	Anritsu	ML2495A	1218010	N/A	Mar. 28, 2013	May 08, 2013~ May 18, 2013	Mar. 27, 2014	Conducted (TH01-SZ)
Power Senso	Anritsu	MA2411B	1207253	N/A	Mar. 28, 2013	May 08, 2013~ May 18, 2013	Mar. 27, 2014	Conducted (TH01-SZ)
DC Power Supply	TOPWORD	3303DR	714621	N/A	Nov. 19, 2012	May 08, 2013~ May 18, 2013	Nov. 18, 2013	Conducted (TH01-SZ)
Thermal Chamber	Hongzhan	LP-150U	HD20120425	N/A	Jun. 11, 2012	May 08, 2013~ May 18, 2013	Jun. 10, 2013	Conducted (TH01-SZ)
BT Base Station	ANRITSU	MT8852B	6K00004935	BT EDR	Oct. 12, 2012	May 08, 2013~ May 18, 2013	Oct. 11, 2013	Conducted (TH01-SZ)
ESCI TEST Receiver	R&S	ESCI	100724	9K-3GHz	Mar. 28, 2013	May 28, 2013	Mar. 27, 2014	Radiation (03CH01-SZ)
Spectrum Analyzer	R&S	FSP30	101362	9kHz~30GHz	Oct. 11, 2012	May 28, 2013	Oct. 10, 2013	Radiation (03CH01-SZ)
Double Ridge Horn Antenna	ETS Lindgren	3117	00119436	1GHz~18GHz	Oct. 12, 2012	May 28, 2013	Oct. 11, 2013	Radiation (03CH01-SZ)
Bilog Antenna	SCHAFFNER	CBL6112B	2614	30Mhz~2Ghz	Nov. 03, 2012	May 28, 2013	Nov. 02, 2013	Radiation (03CH01-SZ)
Amplifier	ADVANTEST	BB525C	E9007003	9K-3000MHz GAIN 30db	Mar. 28, 2013	May 28, 2013	Mar. 27, 2014	Radiation (03CH01-SZ)
Amplifier	Yiai	AV3860B	04030	2GHz~26.5GHz	Mar. 28, 2013	May 28, 2013	Mar. 27, 2014	Radiation (03CH01-SZ)
SHF-EHF-Horn	Schwarzbeck	BBHA9170	BBHA9170249	14GHz~40Ghz	Nov. 23, 2012	May 28, 2013	Nov. 22, 2013	Radiation (03CH01-SZ)
Loop Antenna	R&S	HFH2-Z2	100321	9KHZ-30MHZ	Oct. 22, 2012	May 28, 2013	Oct. 21, 2013	Radiation (03CH01-SZ)
System Simulator	Agilent	E5515C	MY50264168	GSM/WCDMA /CDMA2000	Oct. 09, 2012	May 28, 2013	Oct. 08, 2013	Radiation (03CH01-SZ)
BT Base Station	ANRITSU	MT8852B	6K00004935	BT EDR	Oct. 12, 2012	May 28, 2013	Oct. 11, 2013	Radiation (03CH01-SZ)
ESCIO TEST Receiver	R&S	1142.8007.0 3	100724	9K-3GHz	Mar. 28, 2013	May 10, 2013	Mar. 27, 2014	Conduction (CO01-SZ)
AC LISN	ETS-LINDGREN	3816/2SH	00103912	9KHZ~30MHZ	Mar. 28, 2013	May 10, 2013	Mar. 27, 2014	Conduction (CO01-SZ)
AC LISN	ETS-LINDGREN	3816/2SH	00103892	9KHZ~30MHZ	Mar. 28, 2013	May 10, 2013	Mar. 27, 2014	Conduction (CO01-SZ)
AC Source	Chroma	61602	616020000891	N/A	Nov.20, 2012	May 10, 2013	Nov. 19, 2013	Conduction (CO01-SZ)
System Simulator	Agilent	E5515C	MY50264168	GSM/WCDMA /CDMA2000	Oct. 09, 2012	May 10, 2013	Oct. 08, 2013	Conduction (CO01-SZ)



## 5 Uncertainty of Evaluation

### Uncertainty of Conducted Emission Measurement (150 KHz ~ 30 MHz)

Measuring Uncertainty for a Level of Confidence of 95% ( $U = 2Uc(y)$ )	2.26
---	------

### Uncertainty of Radiated Emission Measurement (30 MHz ~ 1000 MHz)

Measuring Uncertainty for a Level of Confidence of 95% ( $U = 2Uc(y)$ )	2.54
---	------

### Uncertainty of Radiated Emission Measurement (1 GHz ~ 40 GHz)

Measuring Uncertainty for a Level of Confidence of 95% ( $U = 2Uc(y)$ )	4.72
---	------



## **Appendix A. Photographs of EUT**

Please refer to Sporton report number EP350312 as below.