



FCC RF Test Report

APPLICANT : Corporativo Lanix S.A. de C.V.
EQUIPMENT : Smart phone
BRAND NAME : LANIX
MODEL NAME : Ilium L820
FCC ID : ZC4L820
STANDARD : FCC 47 CFR Part 2, 22(H), 24(E)
CLASSIFICATION : PCS Licensed Transmitter Held to Ear (PCE)

The product was received on Sep. 22, 2014 and testing was completed on Oct. 04, 2014. We, SPORTON INTERNATIONAL (SHENZHEN) INC., would like to declare that the tested sample has been evaluated in accordance with the test procedures given in ANSI / TIA / EIA-603-C-2004 and has been in compliance with the applicable technical standards.

The test results in this report apply exclusively to the tested model / sample. Without written approval of SPORTON INTERNATIONAL (SHENZHEN) INC., the test report shall not be reproduced except in full.

Reviewed by: Joseph Lin / Supervisor

Approved by: Jones Tsai / Manager



SPORTON INTERNATIONAL (SHENZHEN) INC.

No. 3 Building, the third floor of south, Shahe River west, Fengzeyuan warehouse, Nanshan District, Shenzhen, Guangdong, P.R.C.



TABLE OF CONTENTS

REVISION HISTORY..... 3

SUMMARY OF TEST RESULT 4

1 GENERAL DESCRIPTION 5

 1.1 Applicant..... 5

 1.2 Manufacturer 5

 1.3 Feature of Equipment Under Test..... 5

 1.4 Product Specification of Equipment Under Test 6

 1.5 Modification of EUT 6

 1.6 Maximum ERP/EIRP Power, Frequency Tolerance, and Emission Designator 7

 1.7 Testing Site 7

 1.8 Applied Standards 8

2 TEST CONFIGURATION OF EQUIPMENT UNDER TEST 9

 2.1 Test Mode..... 9

 2.2 Connection Diagram of Test System 11

 2.3 Support Unit used in test configuration and system..... 11

 2.4 Measurement Results Explanation Example 12

3 TEST RESULT 13

 3.1 Conducted Output Power Measurement..... 13

 3.2 Peak-to-Average Ratio 15

 3.3 Effective Radiated Power and Effective Isotropic Radiated Power Measurement 23

 3.4 99% Occupied Bandwidth and 26dB Bandwidth Measurement..... 29

 3.5 Band Edge Measurement..... 49

 3.6 Conducted Spurious Emission Measurement 63

 3.7 Field Strength of Spurious Radiation Measurement 80

 3.8 Frequency Stability Measurement..... 100

4 LIST OF MEASURING EQUIPMENT 105

5 UNCERTAINTY OF EVALUATION 106

APPENDIX A. SETUP PHOTOGRAPHS



REVISION HISTORY

REPORT NO.	VERSION	DESCRIPTION	ISSUED DATE
FG492206A	Rev. 01	Initial issue of report	Oct. 21, 2014



SUMMARY OF TEST RESULT

Report Section	FCC Rule	Description	Limit	Result	Remark
3.1	§2.1046	Conducted Output Power	N/A	PASS	-
3.2	§24.232(d)	Peak-to-Average Ratio	<13 dB	PASS	-
3.3	§22.913(a)(2)	Effective Radiated Power	< 7 Watts	PASS	-
	§24.232(c)	Equivalent Isotropic Radiated Power	< 2 Watts	PASS	-
3.4	§2.1049 §22.917(b) §24.238(b)	Occupied Bandwidth	N/A	PASS	-
3.5	§2.1051 §22.917(a) §24.238(a)	Band Edge Measurement	< 43+10log ₁₀ (P[Watts])	PASS	-
3.6	§2.1051 §22.917(a) §24.238(a)	Conducted Spurious Emission	< 43+10log ₁₀ (P[Watts])	PASS	-
3.7	§2.1053 §22.917(a) §24.238(a)	Field Strength of Spurious Radiation	< 43+10log ₁₀ (P[Watts])	PASS	Under limit 6.08 dB at 2472.600 MHz
3.8	§2.1055 §22.355	Frequency Stability for Temperature & Voltage	< 2.5 ppm	PASS	-
	§2.1055 §24.235		within authorized band		



1 General Description

1.1 Applicant

Corporativo Lanix S.A. de C.V.

Carretera Internacional Hermosillo-Nogales Km 8.5, Hermosillo Sonora, Mexico

1.2 Manufacturer

Tinno Mobile Technology Corp.

4/F, H-3 Building, OCT Eastern industrial Park, No.1 XiangShan East Road, Nan Shan District, Shenzhen, P.R.China

1.3 Product Feature of Equipment Under Test

Product Feature	
Equipment	Smart phone
Brand Name	LANIX
Model Name	Ilium L820
FCC ID	ZC4L820
EUT supports Radios application	GSM/GPRS/EGPRS/WCDMA/HSPA/HSPA+(Downlink Only)/LTE WLAN 2.4GHz 802.11b/g/n HT20/HT40/ Bluetooth v3.0 + EDR/Bluetooth v4.0 LE
HW Version	V1.0
SW Version	Ilium L820_CLARO_SW_01
EUT Stage	Pre-Production

Remark: The above EUT's information was declared by manufacturer. Please refer to the specifications or user's manual for more detailed description.

1.4 Product Specification subjective to this standard

Product Specification subjective to this standard	
Tx Frequency	GSM850: 824.2 MHz ~ 848.8 MHz GSM1900: 1850.2 MHz ~ 1909.8MHz WCDMA Band V: 826.4 MHz ~ 846.6 MHz WCDMA Band II: 1852.4 MHz ~ 1907.6 MHz
Rx Frequency	GSM850: 869.2 MHz ~ 893.8 MHz GSM1900: 1930.2 MHz ~ 1989.8 MHz WCDMA Band V: 871.4 MHz ~ 891.6 MHz WCDMA Band II: 1932.4 MHz ~ 1987.6 MHz
Maximum Output Power to Antenna	GSM850 : 31.68 dBm GSM1900 : 28.45 dBm WCDMA Band V : 22.50 dBm WCDMA Band II : 22.85 dBm
Antenna Type	IFA Antenna
Type of Modulation	GSM: GMSK GPRS: GMSK EDGE: GMSK / 8PSK WCDMA: QPSK (Uplink) HSDPA: QPSK (Uplink) HSUPA: QPSK (Uplink) HSPA+ : 16QAM (Downlink Only)

1.5 Modification of EUT

No modifications are made to the EUT during all test items.



1.6 Maximum ERP/EIRP Power, Frequency Tolerance, and Emission Designator

FCC Rule	System	Type of Modulation	Maximum ERP/EIRP (W)	Frequency Tolerance (ppm)	Emission Designator
Part 22	GSM850 GSM	GMSK	0.7790	0.0036 ppm	249KGXW
Part 22	GSM850 EDGE class 8	8PSK	0.1519	0.0048 ppm	253KG7W
Part 22	WCDMA Band V RMC 12.2Kbps	QPSK	0.0703	0.0036 ppm	4M23F9W
Part 24	GSM1900 GSM	GMSK	1.5206	0.0037 ppm	249KGXW
Part 24	GSM1900 EDGE class 8	8PSK	0.7221	0.0027 ppm	255KG7W
Part 24	WCDMA Band II RMC 12.2Kbps	QPSK	0.4084	0.0016 ppm	4M24F9W

1.7 Testing Location

Test Site	SPORTON INTERNATIONAL (SHENZHEN) INC.		
Test Site Location	No. 3 Building, the third floor of south, Shahe River west, Fengzeyuan warehouse, Nanshan District, Shenzhen, Guangdong, P.R.C. TEL: +86-755-3320-2398		
Test Site No.	Sporton Site No.		FCC Registration No.
	TH01-SZ	03CH01-SZ	831040

Test Site	SPORTON INTERNATIONAL (SHENZHEN) INC.		
Test Site Location	No. 101, Complex Building C, Guanlong Village, Xili Town, Nanshan District, Shenzhen, Guangdong, P.R.C. TEL: +86-755-8637-9589 FAX: +86-755-8637-9595		
Test Site No.	Sporton Site No.		
	OTA01-SZ		



1.8 Applicable Standards

According to the specifications of the manufacturer, the EUT must comply with the requirements of the following standards:

- ♦ FCC 47 CFR Part 2, 22(H), 24(E)
- ♦ ANSI / TIA / EIA-603-C-2004
- ♦ FCC KDB 971168 D01 Power Meas. License Digital Systems v02r01

Remark:

1. All test items were verified and recorded according to the standards and without any deviation during the test.
2. This EUT has also been tested and complied with the requirements of FCC Part 15, Subpart B, recorded in a separate test report.



2 Test Configuration of Equipment Under Test

2.1 Test Mode

Antenna port conducted and radiated test items were performed according to KDB 971168 D01 Power Meas. License Digital Systems v02r01 with maximum output power.

Radiated measurements were performed with rotating EUT in different three orthogonal test planes to find the maximum emission.

Radiated emissions were investigated as following frequency range:

1. 30 MHz to 9000 MHz for GSM850 and WCDMA Band V.
2. 30 MHz to 19000 MHz for GSM1900 and WCDMA Band II.

All modes and data rates and positions were investigated.

Test modes are chosen to be reported as the worst case configuration below:

Test Modes		
Band	Radiated TCs	Conducted TCs
GSM 850	<ul style="list-style-type: none">■ GSM Link■ EDGE class 8 Link	<ul style="list-style-type: none">■ GSM Link■ EDGE class 8 Link
GSM 1900	<ul style="list-style-type: none">■ GSM Link■ EDGE class 8 Link	<ul style="list-style-type: none">■ GSM Link■ EDGE class 8 Link
WCDMA Band V	<ul style="list-style-type: none">■ RMC 12.2Kbps Link	<ul style="list-style-type: none">■ RMC 12.2Kbps Link
WCDMA Band II	<ul style="list-style-type: none">■ RMC 12.2Kbps Link	<ul style="list-style-type: none">■ RMC 12.2Kbps Link



Conducted Power Measurement Results:

Conducted Power (*Unit: dBm)						
Band	GSM850			GSM1900		
Channel	128	189	251	512	661	810
Frequency	824.2	836.4	848.8	1850.2	1880.0	1909.8
GSM	31.64	31.66	31.68	28.41	28.40	28.45
GPRS class 8	31.59	31.62	31.64	28.35	28.38	28.40
GPRS class 10	31.04	31.08	31.10	27.86	27.85	27.91
GPRS class 11	29.55	29.60	29.62	26.37	26.34	26.38
GPRS class 12	28.47	28.54	28.58	25.28	25.26	25.30
EGPRS class 8	25.98	26.00	25.91	24.99	24.98	24.95
EGPRS class 10	24.99	25.01	24.93	23.95	23.99	23.91
EGPRS class 11	23.03	23.04	22.98	21.84	21.91	21.82
EGPRS class 12	21.99	22.05	21.96	20.67	20.71	20.66

Conducted Power (*Unit: dBm)						
Band	WCDMA Band V			WCDMA Band II		
Channel	4132	4182	4233	9262	9400	9538
Frequency	826.4	836.4	846.6	1852.4	1880.0	1907.6
AMR 12.2K	22.48	22.19	21.82	22.83	22.24	21.80
RMC 12.2K	22.50	22.20	21.84	22.85	22.25	21.82
HSDPA Subtest-1	21.85	21.60	21.25	22.21	21.62	20.91
HSDPA Subtest-2	21.87	21.59	21.25	22.22	21.59	20.90
HSDPA Subtest-3	21.42	21.15	20.78	21.77	21.16	20.47
HSDPA Subtest-4	21.38	21.13	20.77	21.74	21.12	20.45
HSUPA Subtest-1	19.96	19.68	19.26	20.28	19.64	19.02
HSUPA Subtest-2	19.89	19.63	19.25	20.15	19.64	18.98
HSUPA Subtest-3	20.87	20.61	20.20	21.17	20.61	19.92
HSUPA Subtest-4	19.37	19.05	18.67	19.72	19.07	18.46
HSUPA Subtest-5	21.80	21.60	21.20	22.10	21.50	20.90

2.2 Connection Diagram of Test System

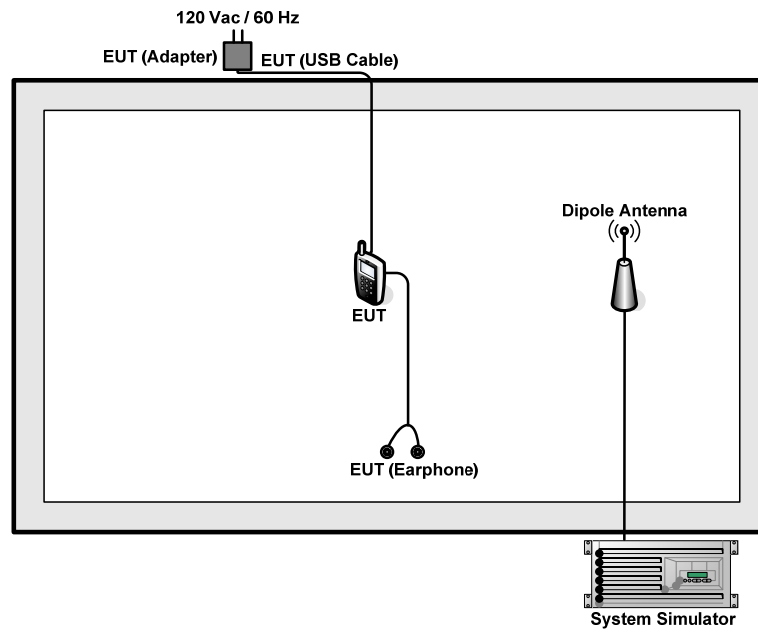

2.3 Support Unit used in test configuration

Item	Equipment	Trade Name	Model No.	FCC ID	Data Cable	Power Cord
1.	System Simulator	R&S	CMU 200	N/A	N/A	Unshielded, 1.8 m
2.	DC Power Supply	GW INSTRON	GPS-3030D	N/A	N/A	Unshielded, 1.8 m



2.4 Measurement Results Explanation Example

For all conducted test items:

The offset level is set in the spectrum analyzer to compensate the RF cable loss and attenuator factor between RF conducted output port and spectrum analyzer. With the offset compensation, the spectrum analyzer reading level will be exactly the RF output level.

The spectrum analyzer offset is derived from RF cable loss and attenuator factor.

Offset = RF cable loss + attenuator factor.

The following shows an offset computation example with RF cable loss 7.5 dB and a 10dB attenuator.

Example :

$$\begin{aligned} \text{Offset(dB)} &= \text{RF cable loss(dB)} + \text{attenuator factor(dB)} \\ &= 7.5 + 10 = 17.5 \text{ (dB)} \end{aligned}$$

3 Test Result

3.1 Conducted Output Power Measurement

3.1.1 Description of the Conducted Output Power Measurement

A system simulator was used to establish communication with the EUT. Its parameters were set to enforce EUT transmitting at the maximum power. The measured power in the radio frequency on the transmitter output terminals shall be reported.

3.1.2 Measuring Instruments

The measuring equipment is listed in the section 4 of this test report.

3.1.3 Test Procedures

1. The transmitter output port was connected to the system simulator.
2. Set EUT at maximum power through system simulator.
3. Select lowest, middle, and highest channels for each band and different modulation.
4. Measure the maximum burst average power for GSM and maximum average power for other modulation signal.

3.1.4 Test Setup

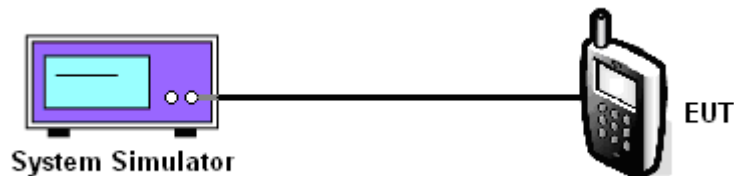



3.1.5 Test Result of Conducted Output Power

Cellular Band									
Modes	GSM850 (GSM)			GSM850 (EDGE class 8)			WCDMA Band V (RMC 12.2Kbps)		
Channel	128 (Low)	189 (Mid)	251 (High)	128 (Low)	189 (Mid)	251 (High)	4132 (Low)	4182 (Mid)	4233 (High)
Frequency (MHz)	824.2	836.4	848.8	824.2	836.4	848.8	826.4	836.4	846.6
Conducted Power (dBm)	31.64	31.66	31.68	25.98	26.00	25.91	22.50	22.20	21.84
Conducted Power (Watts)	1.46	1.47	1.47	0.40	0.40	0.39	0.18	0.17	0.15

PCS Band									
Modes	GSM1900 (GSM)			GSM1900 (EDGE class 8)			WCDMA Band II (RMC 12.2Kbps)		
Channel	512 (Low)	661 (Mid)	810 (High)	512 (Low)	661 (Mid)	810 (High)	9262 (Low)	9400 (Mid)	9538 (High)
Frequency (MHz)	1850.2	1880	1909.8	1850.2	1880	1909.8	1852.4	1880	1907.6
Conducted Power (dBm)	28.41	28.40	28.45	24.99	24.98	24.95	22.85	22.25	21.82
Conducted Power (Watts)	0.69	0.69	0.70	0.32	0.31	0.31	0.19	0.17	0.15

Note: maximum burst average power for GSM, and maximum average power for WCDMA.

3.2 Peak-to-Average Ratio

3.2.1 Description of the PAR Measurement

The peak-to-average ratio (PAR) of the transmission may not exceed 13 dB.

3.2.2 Measuring Instruments

The measuring equipment is listed in the section 4 of this test report.

3.2.3 Test Procedures

1. The testing follows FCC KDB 971168 v02r01 Section 5.7.1.
2. The EUT was connected to the spectrum analyzer and system simulator via a power divider.
3. For GSM/EGPRS operating modes:
 - a. Set EUT in maximum power output.
 - b. Set the RBW = 1MHz, VBW = 3MHz, Peak detector on spectrum analyzer for first trace.
 - c. Set the RBW = 1MHz, VBW = 3MHz, RMS detector on spectrum analyzer for second trace.
 - d. The wanted burst signal is triggered by spectrum analyzer, and measured respectively the peak level and Mean level without burst-off time, after system simulator has synchronized with the spectrum analyzer.
4. For UMTS operating modes:
 - a. Set the CCDF (Complementary Cumulative Distribution Function) option on the spectrum analyzer.
 - b. The highest RF powers were measured and recorded the maximum PAPR level associated with a probability of 0.1 %.
5. Record the deviation as Peak to Average Ratio.

3.2.4 Test Setup

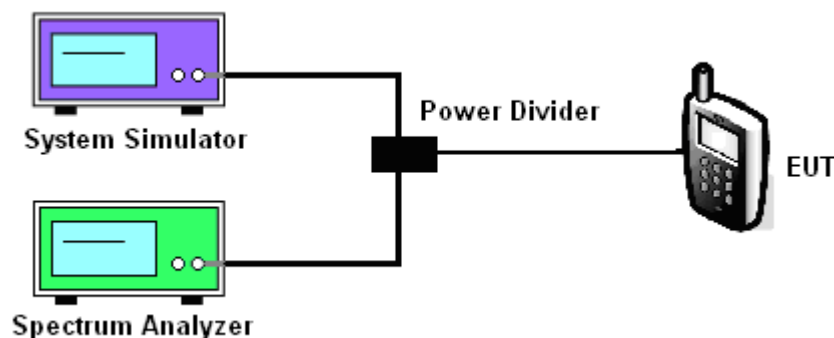



3.2.5 Test Result of Peak-to-Average Ratio

PCS Band									
Modes	GSM1900 (GSM)			GSM1900 (EDGE class 8)			WCDMA Band II (RMC 12.2Kbps)		
Channel	512 (Low)	661 (Mid)	810 (High)	512 (Low)	661 (Mid)	810 (High)	9262 (Low)	9400 (Mid)	9538 (High)
Frequency (MHz)	1850.2	1880	1909.8	1850.2	1880	1909.8	1852.4	1880	1907.6
Peak-to-Average Ratio (dB)	0.23	0.23	0.20	3.09	3.24	2.99	2.55	2.81	2.61



3.2.6 Test Result (Plots) of Peak-to-Average Ratio

Band :	GSM 1900	Test Mode :	GSM Link (GMSK)
---------------	----------	--------------------	-----------------

Peak-to-Average Ratio on Channel 512 (1850.2 MHz)

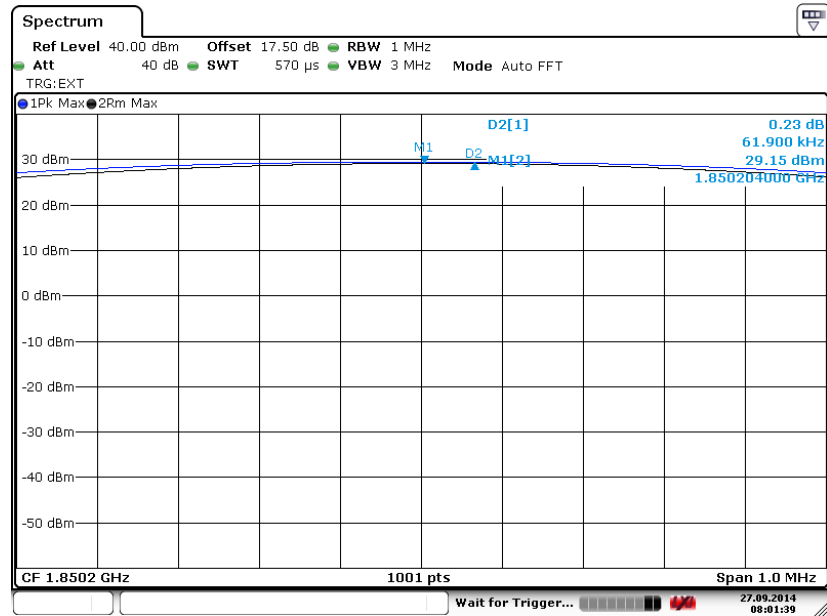

Date: 27.SEP.2014 08:01:39

Peak-to-Average Ratio on Channel 661 (1880.0 MHz)

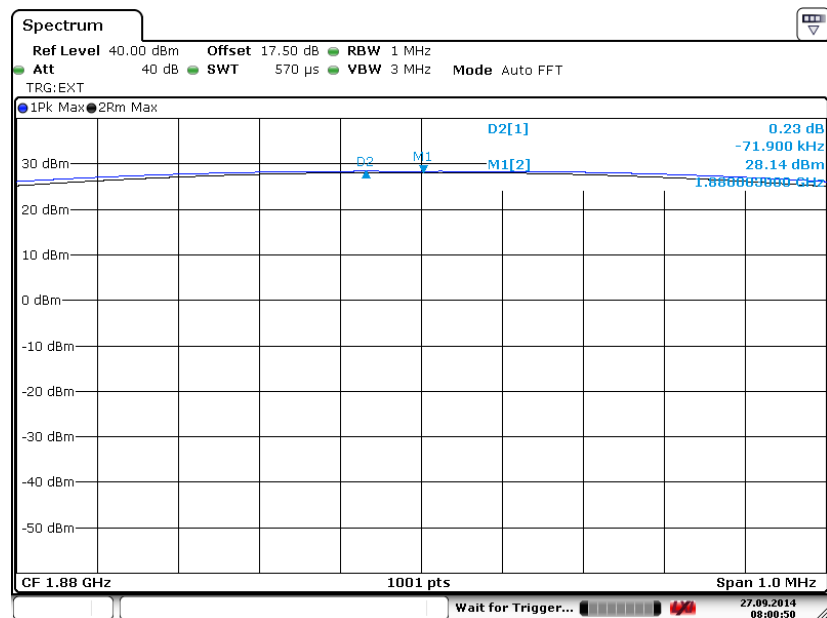

Date: 27.SEP.2014 08:00:50



Peak-to-Average Ratio on Channel 810 (1909.8 MHz)

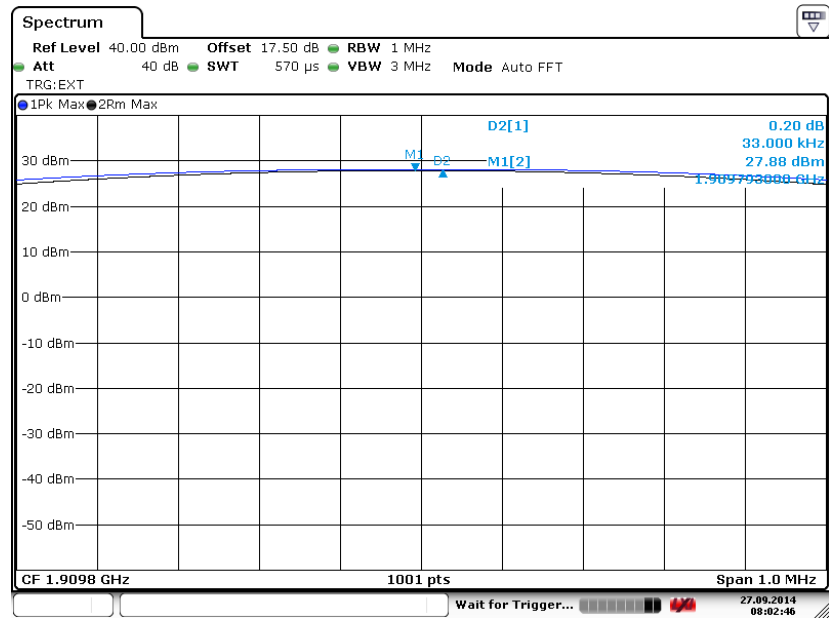

Date: 27.SEP.2014 08:02:46



Band :	GSM 1900	Test Mode :	EDGE class 8 Link (8PSK)
---------------	----------	--------------------	--------------------------

Peak-to-Average Ratio on Channel 512 (1850.2 MHz)

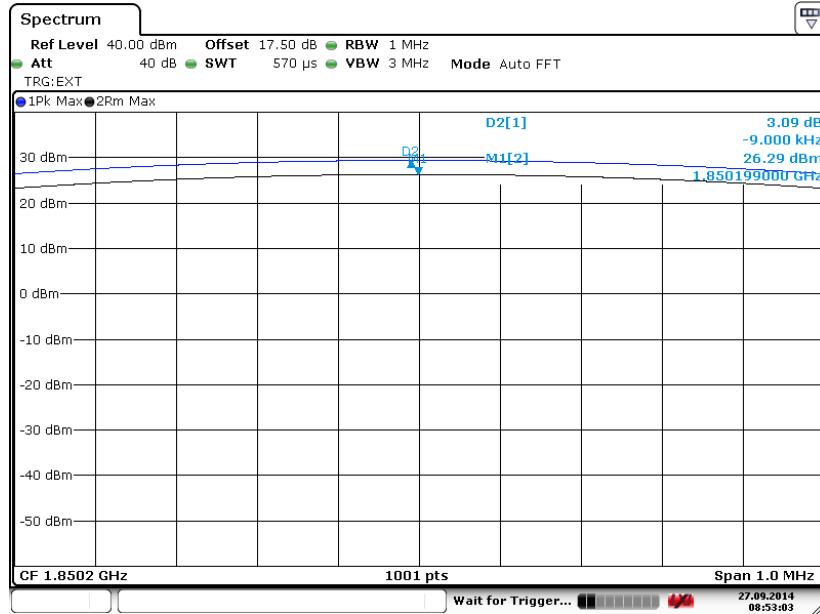

Date: 27.SEP.2014 08:53:03

Peak-to-Average Ratio on Channel 661 (1880.0 MHz)

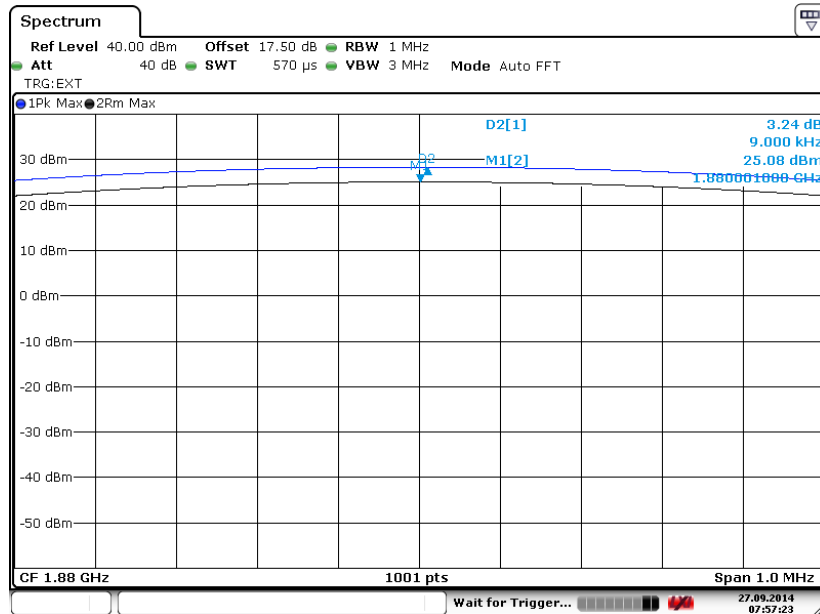

Date: 27.SEP.2014 07:57:23



Peak-to-Average Ratio on Channel 810 (1909.8 MHz)

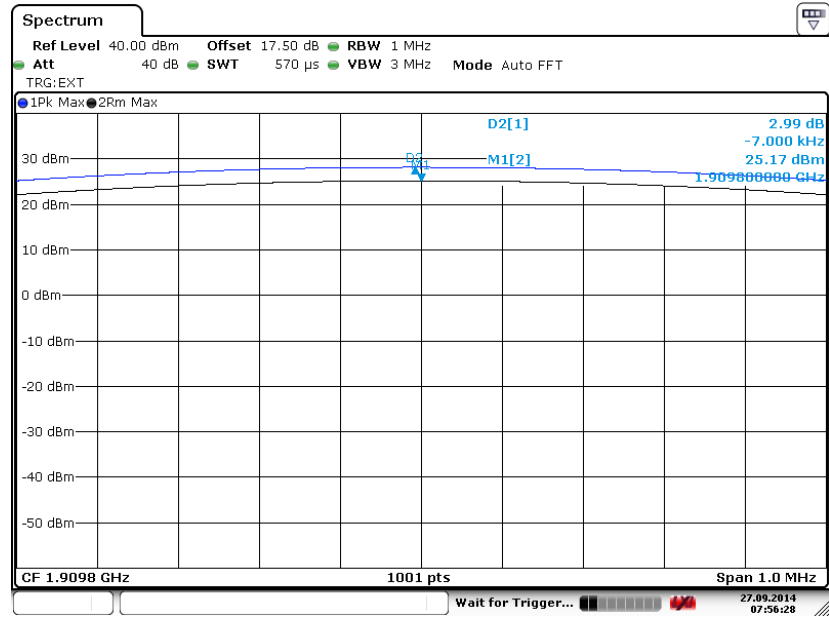

Date: 27.SEP.2014 07:56:28



Band :	WCDMA Band II	Test Mode :	RMC 12.2Kbps Link (QPSK)
--------	---------------	-------------	--------------------------

Peak-to-Average Ratio on Channel 9262 (1852.4 MHz)

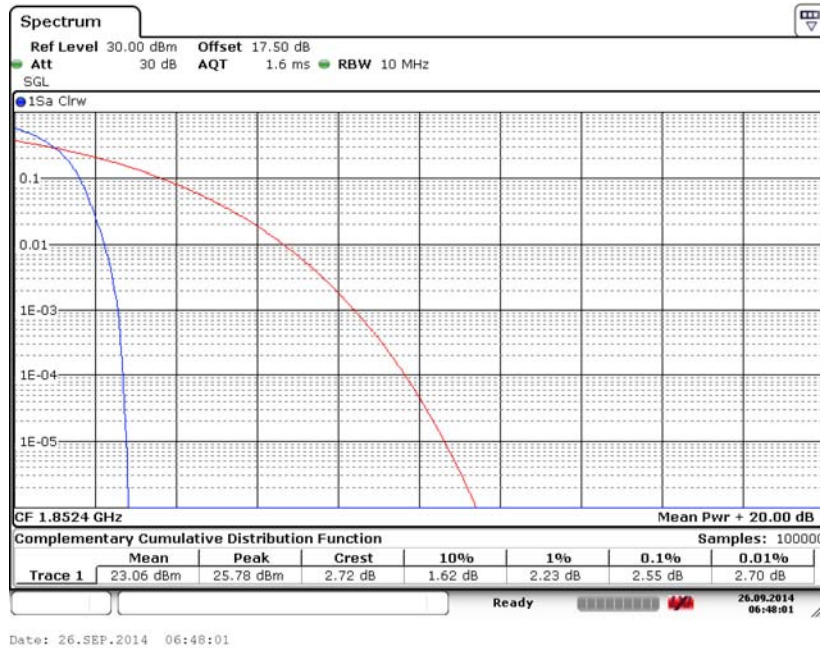

Peak-to-Average Ratio on Channel 9400 (1880.0 MHz)

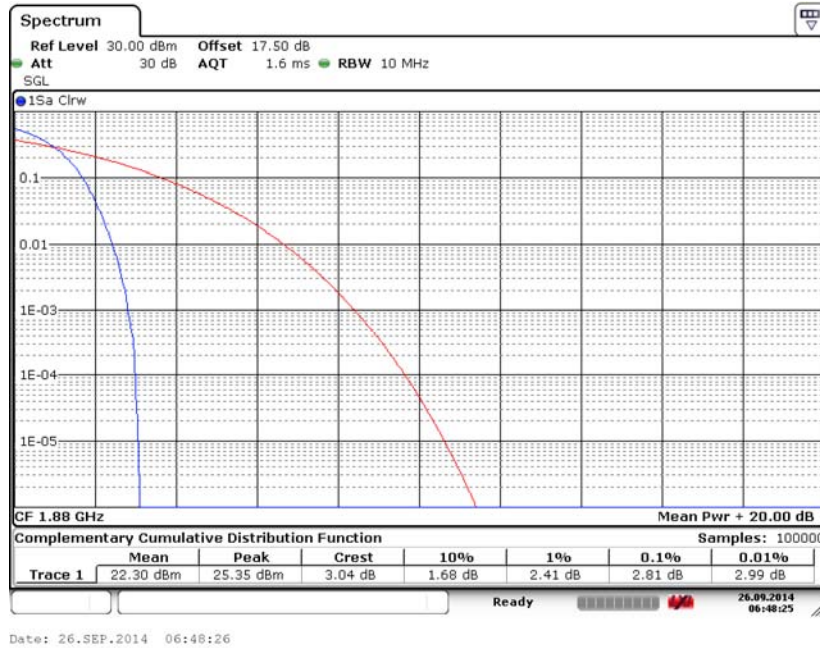



Peak-to-Average Ratio on Channel 9538 (1907.6 MHz)

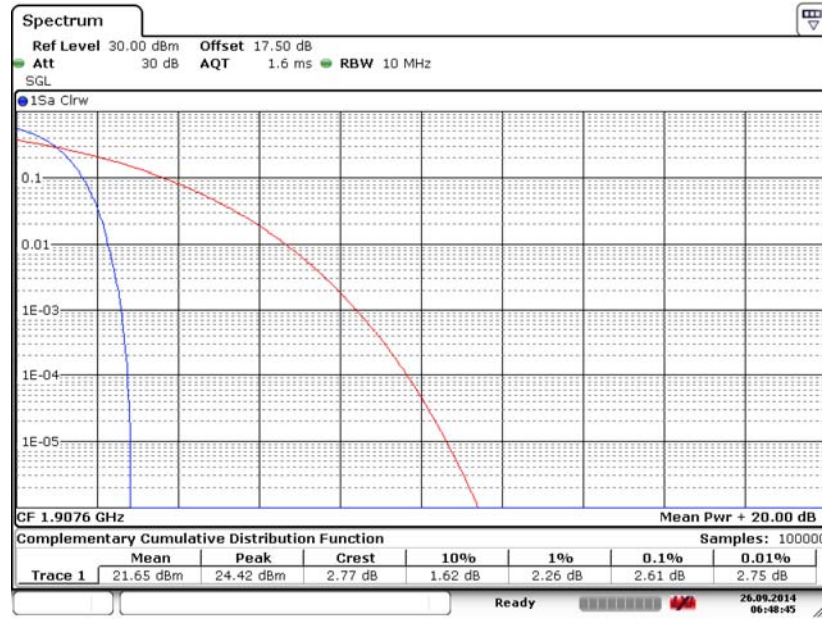

Date: 26.SEP.2014 06:48:46



3.3 Effective Radiated Power and Effective Isotropic Radiated Power Measurement

3.3.1 Description of the ERP/EIRP Measurement

The substitution method, in ANSI / TIA / EIA-603-C-2004, was used for ERP/EIRP measurement, and the spectrum analyzer configuration follows KDB 971168 D01 Power Meas. License Digital Systems v02r01. The ERP of mobile transmitters must not exceed 7 Watts and the EIRP of mobile transmitters are limited to 2 Watts.

3.3.2 Measuring Instruments

The measuring equipment is listed in the section 4 of this test report.

3.3.3 Test Procedures

1. The testing follows FCC KDB 971168 v02r01 Section 5.2.1. (for CDMA/WCDMA), Section 5.2.2.2 (for GSM/GPRS/EDGE) and ANSI / TIA-603-C-2004 Section 2.2.17.
2. The EUT was placed on a turntable 1.5 meters high in a fully anechoic chamber.
3. The EUT was placed 3 meters from the receiving antenna, which was mounted on the antenna tower.
4. GSM operating modes: Set RBW= 1MHz, VBW= 3MHz, RMS detector over burst;
UMTS operating modes: Set RBW= 100 kHz, VBW= 300 kHz, RMS detector over frame, and use channel power option with bandwidth=5MHz, per KDB 971168 D01.
5. The table was rotated 360 degrees to determine the position of the highest radiated power.
6. The height of the receiving antenna is adjusted to look for the maximum ERP/EIRP.
7. Taking the record of maximum ERP/EIRP.
8. A dipole antenna was substituted in place of the EUT and was driven by a signal generator.
9. The conducted power at the terminal of the dipole antenna is measured.
10. Repeat step 3 to step 5 to get the maximum ERP/EIRP of the substitution antenna.
11. $ERP/EIRP = P_s + E_t - E_s + G_s = P_s + R_t - R_s + G_s$

P_s (dBm) : Input power to substitution antenna.

G_s (dBi or dBd) : Substitution antenna Gain.

$E_t = R_t + AF$

$E_s = R_s + AF$

AF (dB/m) : Receive antenna factor

R_t : The highest received signal in spectrum analyzer for EUT.

R_s : The highest received signal in spectrum analyzer for substitution antenna.

3.3.4 Test Setup

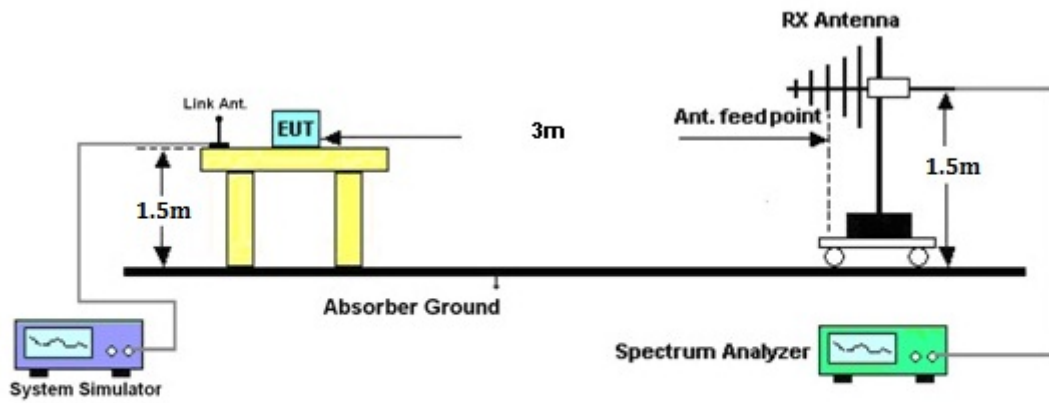



3.3.5 Test Result of ERP

GSM850 (GSM) Radiated Power ERP						
Horizontal Polarization						
Frequency (MHz)	Rt (dBm)	Rs (dBm)	Ps (dBm)	Gs (dBd)	ERP (dBm)	ERP (W)
824.20	-20.05	-48.12	0.00	-1.08	26.99	0.4998
836.40	-19.40	-48.28	0.00	-0.93	27.95	0.6242
848.80	-18.67	-48.35	0.00	-0.76	28.92	0.7790
Vertical Polarization						
Frequency (MHz)	Rt (dBm)	Rs (dBm)	Ps (dBm)	Gs (dBd)	ERP (dBm)	ERP (W)
824.20	-32.96	-47.97	0.00	-1.08	13.93	0.0247
836.40	-32.18	-48.01	0.00	-0.93	14.90	0.0309
848.80	-31.68	-48.05	0.00	-0.76	15.61	0.0364

GSM850 (EDGE class 8) Radiated Power ERP						
Horizontal Polarization						
Frequency (MHz)	Rt (dBm)	Rs (dBm)	Ps (dBm)	Gs (dBd)	ERP (dBm)	ERP (W)
824.20	-26.96	-48.12	0.00	-1.08	20.08	0.1018
836.40	-26.42	-48.28	0.00	-0.93	20.93	0.1238
848.80	-25.77	-48.35	0.00	-0.76	21.82	0.1519
Vertical Polarization						
Frequency (MHz)	Rt (dBm)	Rs (dBm)	Ps (dBm)	Gs (dBd)	ERP (dBm)	ERP (W)
824.20	-39.91	-47.97	0.00	-1.08	6.98	0.0050
836.40	-39.46	-48.01	0.00	-0.93	7.62	0.0058
848.80	-38.90	-48.05	0.00	-0.76	8.39	0.0069



WCDMA Band V (RMC 12.2Kbps) Radiated Power ERP						
Horizontal Polarization						
Frequency (MHz)	Rt (dBm)	Rs (dBm)	Ps (dBm)	Gs (dBd)	ERP (dBm)	ERP (W)
826.40	-29.28	-48.12	0.00	-1.08	17.76	0.0597
836.40	-29.18	-48.28	0.00	-0.93	18.17	0.0656
846.60	-29.12	-48.35	0.00	-0.76	18.47	0.0703
Vertical Polarization						
Frequency (MHz)	Rt (dBm)	Rs (dBm)	Ps (dBm)	Gs (dBd)	ERP (dBm)	ERP (W)
826.40	-42.07	-47.97	0.00	-1.08	4.82	0.0030
836.40	-42.02	-48.01	0.00	-0.93	5.06	0.0032
846.60	-42.20	-48.05	0.00	-0.76	5.09	0.0032



3.3.6 Test Result of EIRP

GSM1900 (GSM) Radiated Power EIRP						
Horizontal Polarization						
Frequency (MHz)	Rt (dBm)	Rs (dBm)	Ps (dBm)	Gs (dBi)	EIRP (dBm)	EIRP (W)
1850.20	-22.02	-51.88	0.00	1.96	31.82	1.5206
1880.00	-23.82	-52.99	0.00	2.00	31.17	1.3095
1909.80	-25.43	-54.28	0.00	1.98	30.83	1.2119
Vertical Polarization						
Frequency (MHz)	Rt (dBm)	Rs (dBm)	Ps (dBm)	Gs (dBi)	EIRP (dBm)	EIRP (W)
1850.20	-22.35	-52.13	0.00	1.96	31.74	1.4920
1880.00	-24.01	-53.17	0.00	2.00	31.16	1.3057
1909.80	-25.31	-54.13	0.00	1.98	30.80	1.2027

GSM1900 (EDGE class 8) Radiated Power EIRP						
Horizontal Polarization						
Frequency (MHz)	Rt (dBm)	Rs (dBm)	Ps (dBm)	Gs (dBi)	EIRP (dBm)	EIRP (W)
1850.20	-25.25	-51.88	0.00	1.96	28.59	0.7221
1880.00	-27.47	-52.99	0.00	2.00	27.52	0.5649
1909.80	-29.68	-54.28	0.00	1.98	26.58	0.4545
Vertical Polarization						
Frequency (MHz)	Rt (dBm)	Rs (dBm)	Ps (dBm)	Gs (dBi)	EIRP (dBm)	EIRP (W)
1850.20	-25.60	-52.13	0.00	1.96	28.49	0.7066
1880.00	-27.55	-53.17	0.00	2.00	27.62	0.5784
1909.80	-29.43	-54.13	0.00	1.98	26.68	0.4653



WCDMA Band II (RMC 12.2Kbps) Radiated Power EIRP						
Horizontal Polarization						
Frequency (MHz)	Rt (dBm)	Rs (dBm)	Ps (dBm)	Gs (dBi)	EIRP (dBm)	EIRP (W)
1852.40	-27.73	-51.88	0.00	1.96	26.11	0.4084
1880.00	-29.91	-52.99	0.00	2.00	25.08	0.3218
1907.60	-31.79	-54.28	0.00	1.98	24.47	0.2801
Vertical Polarization						
Frequency (MHz)	Rt (dBm)	Rs (dBm)	Ps (dBm)	Gs (dBi)	EIRP (dBm)	EIRP (W)
1852.40	-28.02	-52.13	0.00	1.96	26.07	0.4049
1880.00	-30.23	-53.17	0.00	2.00	24.94	0.3119
1907.60	-31.60	-54.13	0.00	1.98	24.51	0.2825

3.4 99% Occupied Bandwidth and 26dB Bandwidth Measurement

3.4.1 Description of 99% Occupied Bandwidth and 26dB Bandwidth Measurement

The 99% occupied bandwidth is the width of a frequency band such that, below the lower and above the upper frequency limits, the mean powers emitted are each equal to a specified percentage 0.5% of the total mean transmitted power.

The emission bandwidth is defined as the width of the signal between two points, located at the 2 sides of the carrier frequency, outside of which all emissions are attenuated at least 26 dB below the transmitter power.

3.4.2 Measuring Instruments

The measuring equipment is listed in the section 4 of this test report.

3.4.3 Test Procedures

1. The testing follows FCC KDB 971168 v02r01 Section 4.2.
2. The EUT was connected to the spectrum analyzer and system simulator via a power divider.
3. The RF output of the EUT was connected to the spectrum analyzer by RF cable and attenuator. The path loss was compensated to the results for each measurement.
4. The 99% occupied bandwidth were measured, set RBW= 1% of span, VBW= 3*RBW, sample detector, trace maximum hold.
5. The 26dB bandwidth were measured, set RBW= 1% of EBW, VBW= 3*RBW, peak detector, trace maximum hold.

3.4.4 Test Setup

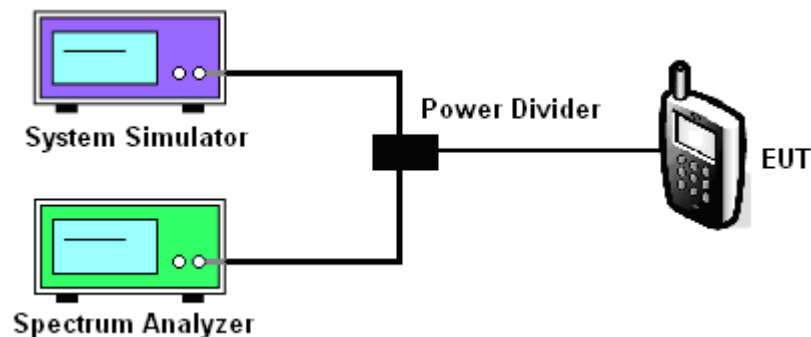



3.4.5 Test Result of Occupied Bandwidth and 26dB Bandwidth

Cellular Band						
Modes	GSM850 (GSM)			GSM850 (EDGE class 8)		
Channel	128 (Low)	189 (Mid)	251 (High)	128 (Low)	189 (Mid)	251 (High)
Frequency (MHz)	824.2	836.4	848.8	824.2	836.4	848.8
99% OBW (kHz)	247.47	248.91	247.47	253.26	253.26	247.47
26dB BW (kHz)	309.70	305.40	303.90	308.20	301.00	303.90

PCS Band						
Modes	GSM1900 (GSM)			GSM1900 (EDGE class 8)		
Channel	512 (Low)	661 (Mid)	810 (High)	512 (Low)	661 (Mid)	810 (High)
Frequency (MHz)	1850.2	1880	1909.8	1850.2	1880	1909.8
99% OBW (kHz)	246.02	244.57	248.91	250.36	254.70	250.36
26dB BW (kHz)	302.50	306.80	309.70	312.60	311.10	315.50

Cellular Band			
Modes	WCDMA Band V (RMC 12.2Kbps)		
Channel	4132 (Low)	4182 (Mid)	4233 (High)
Frequency (MHz)	826.4	836.4	846.6
99% OBW (MHz)	4.23	4.21	4.21
26dB BW (MHz)	4.88	4.86	4.86

PCS Band			
Modes	WCDMA Band II (RMC 12.2Kbps)		
Channel	9262 (Low)	9400 (Mid)	9538 (High)
Frequency (MHz)	1852.4	1880	1907.6
99% OBW (MHz)	4.24	4.23	4.21
26dB BW (MHz)	4.88	4.85	4.86



3.4.6 Test Result (Plots) of Occupied Bandwidth and 26dB Bandwidth

Band :	GSM 850	Test Mode :	GSM Link (GMSK)
--------	---------	-------------	-----------------

99% Occupied Bandwidth Plot on Channel 128 (824.2 MHz)

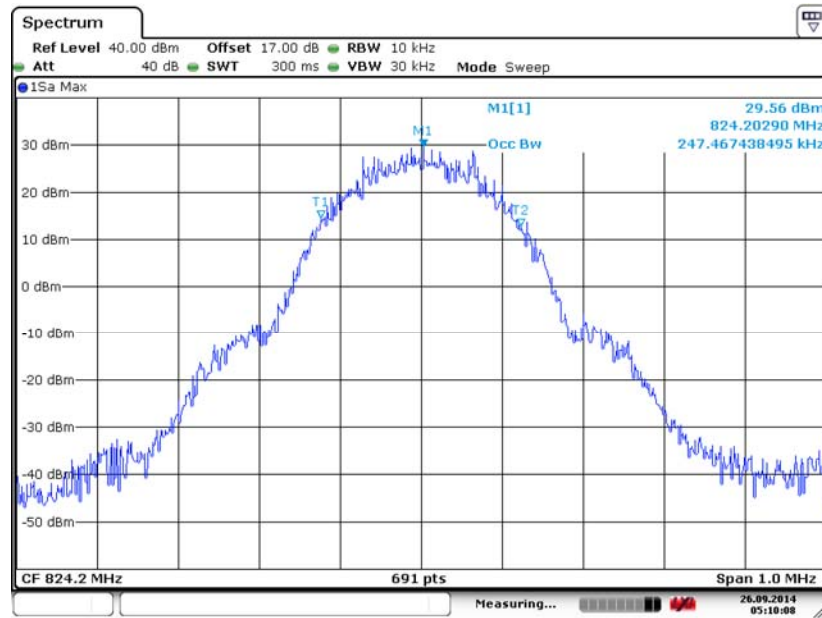

Date: 26.SEP.2014 05:10:08

26dB Bandwidth Plot on Channel 128 (824.2 MHz)

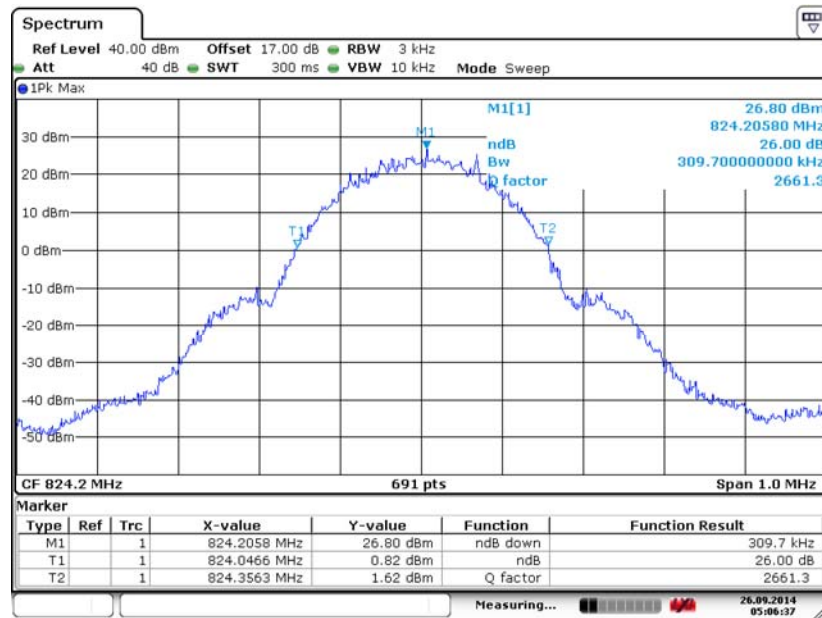

Date: 26.SEP.2014 05:06:38



99% Occupied Bandwidth Plot on Channel 189 (836.4 MHz)

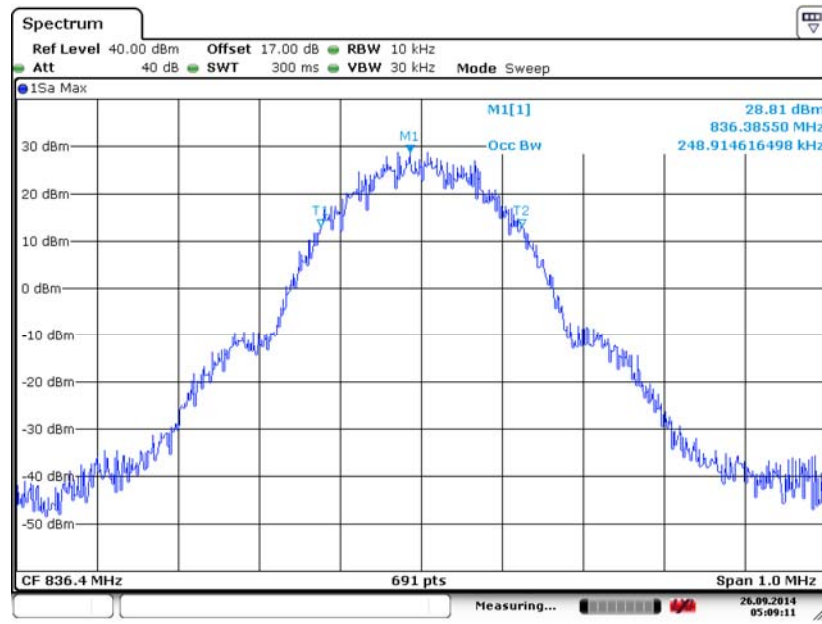

Date: 26.SEP.2014 05:09:11

26dB Bandwidth Plot on Channel 189 (836.4 MHz)

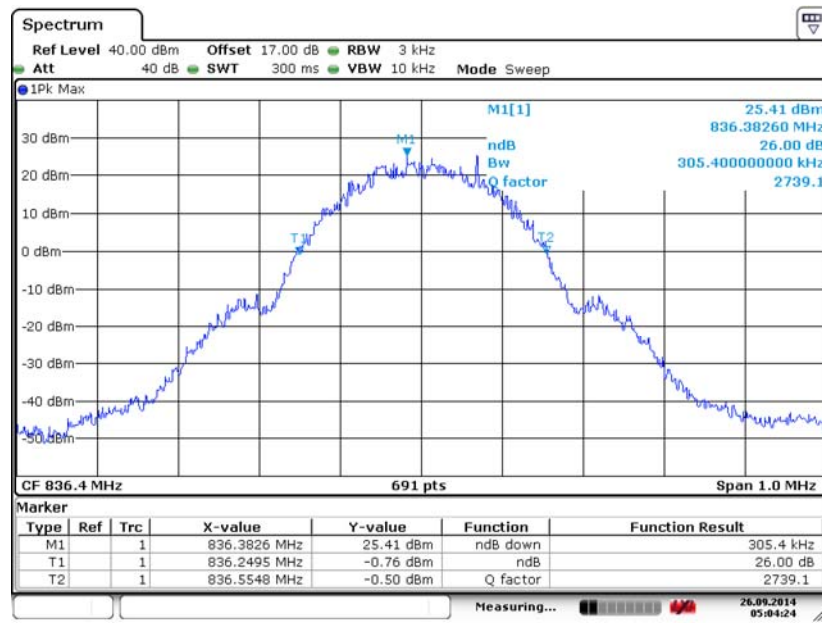

Date: 26.SEP.2014 05:04:24



99% Occupied Bandwidth Plot on Channel 251 (848.8 MHz)

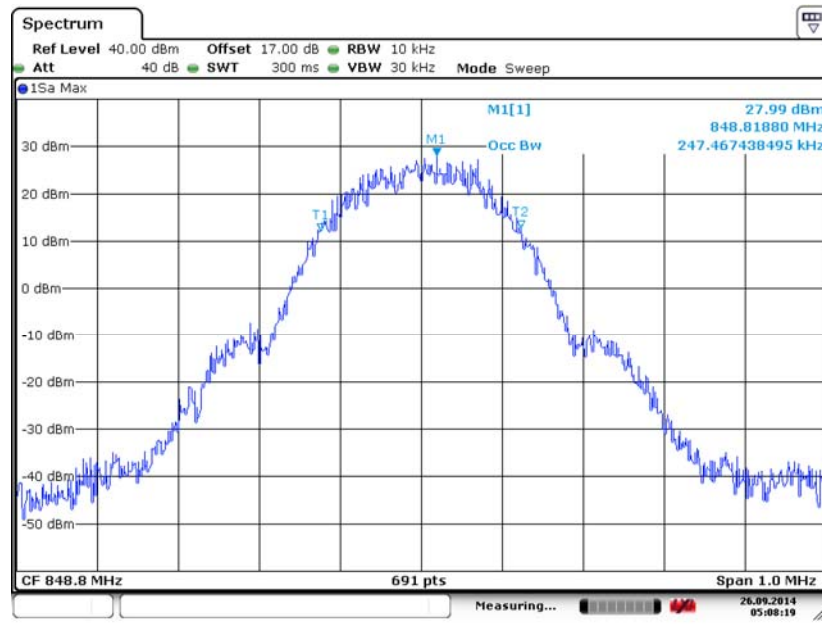

Date: 26.SEP.2014 05:08:20

26dB Bandwidth Plot on Channel 251 (848.8 MHz)

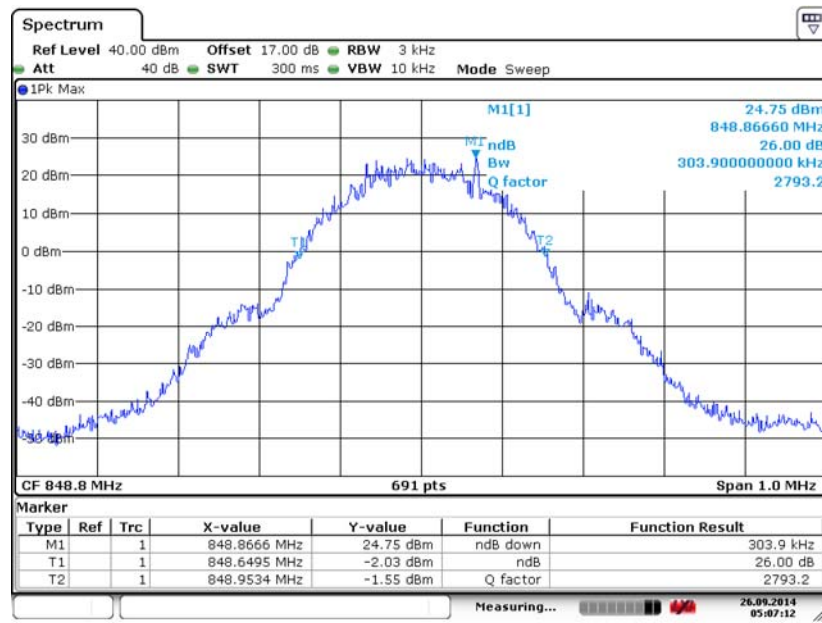

Date: 26.SEP.2014 05:07:13



Band :	GSM 850	Test Mode :	EDGE class 8 Link (8PSK)
---------------	---------	--------------------	--------------------------

99% Occupied Bandwidth Plot on Channel 128 (824.2 MHz)

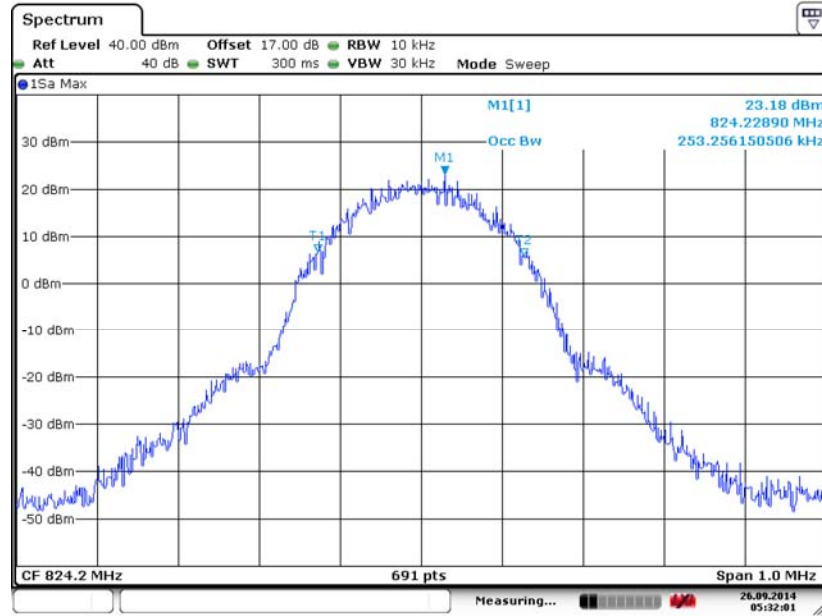

Date: 26.SEP.2014 05:32:01

26dB Bandwidth Plot on Channel 128 (824.2 MHz)

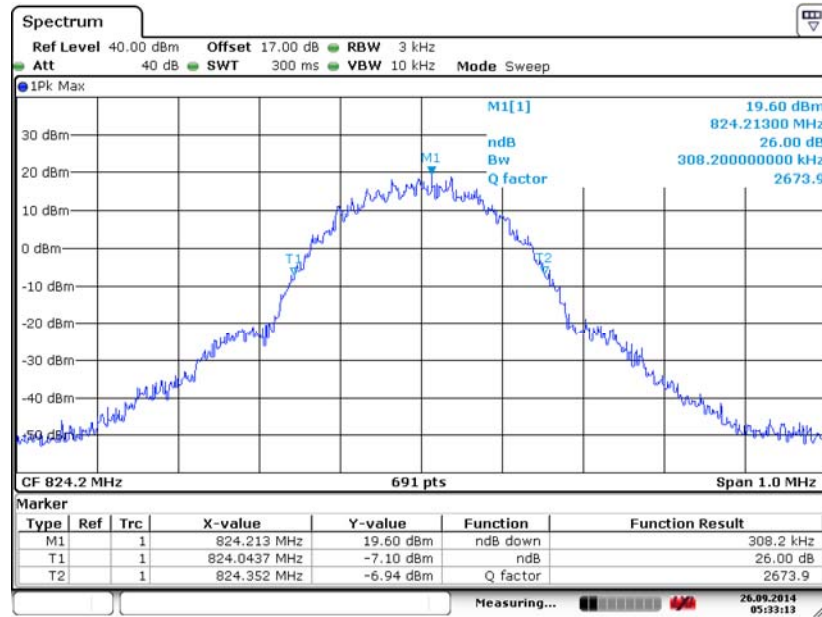

Date: 26.SEP.2014 05:33:14



99% Occupied Bandwidth Plot on Channel 189 (836.4 MHz)

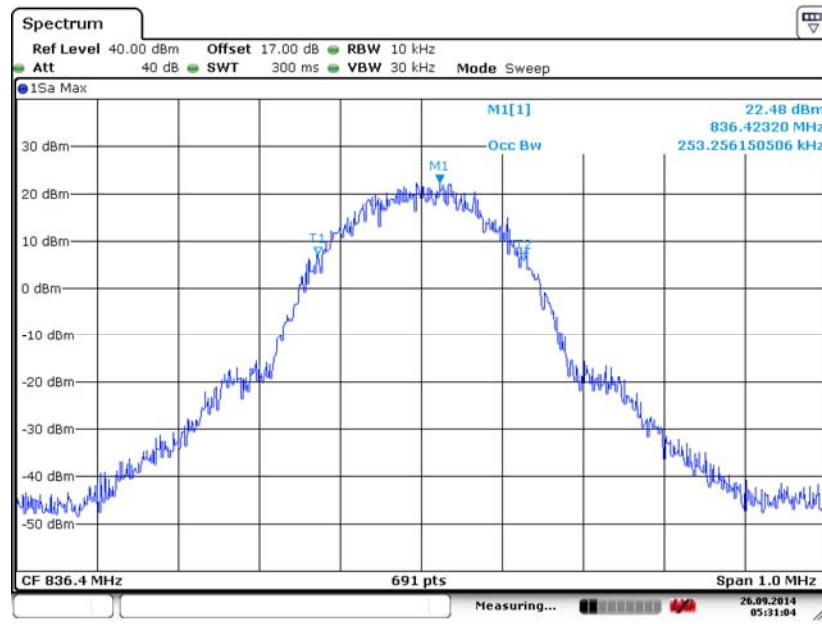

Date: 26.SEP.2014 05:31:05

26dB Bandwidth Plot on Channel 189 (836.4 MHz)

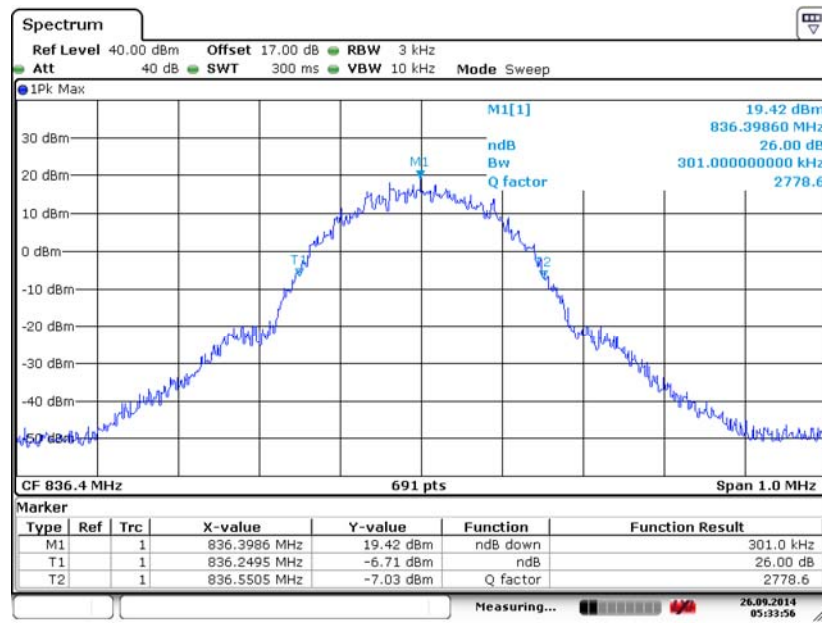

Date: 26.SEP.2014 05:33:57



99% Occupied Bandwidth Plot on Channel 251 (848.8 MHz)

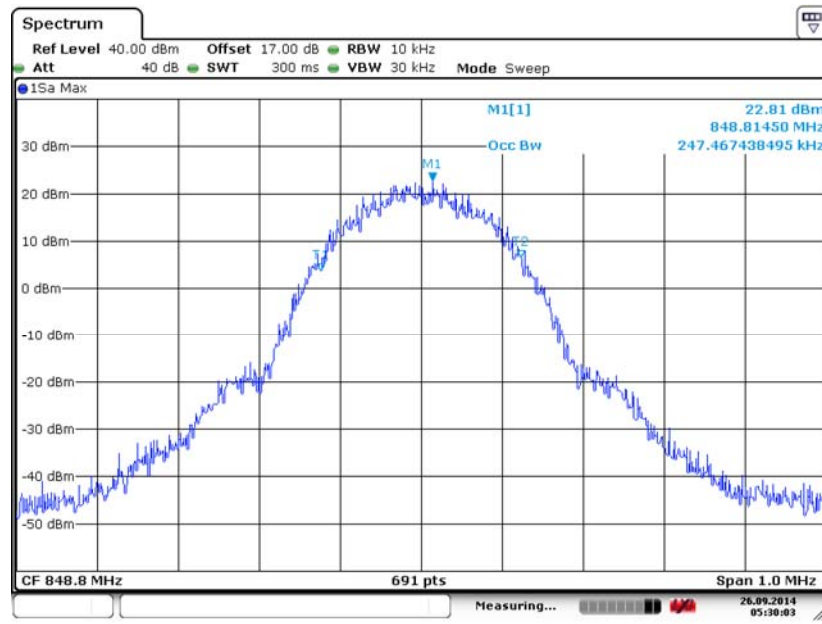

Date: 26.SEP.2014 05:30:03

26dB Bandwidth Plot on Channel 251 (848.8 MHz)

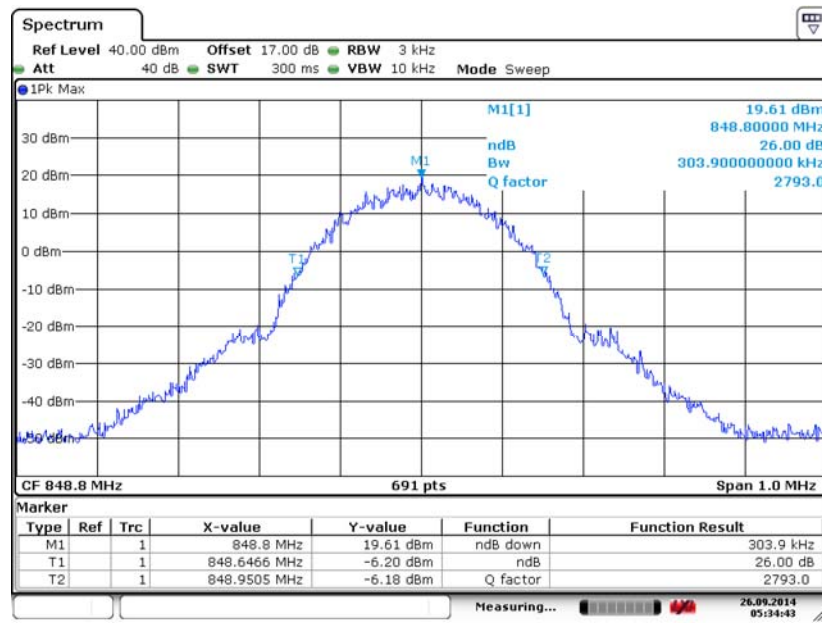

Date: 26.SEP.2014 05:34:44



Band :	GSM 1900	Test Mode :	GSM Link (GMSK)
--------	----------	-------------	-----------------

99% Occupied Bandwidth Plot on Channel 512 (1850.2 MHz)

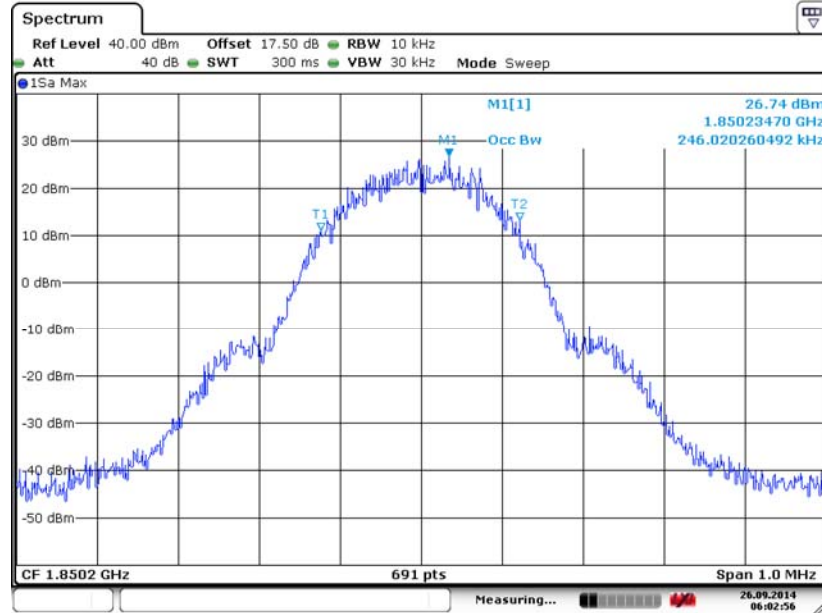

Date: 26.SEP.2014 06:02:57

26dB Bandwidth Plot on Channel 512 (1850.2 MHz)

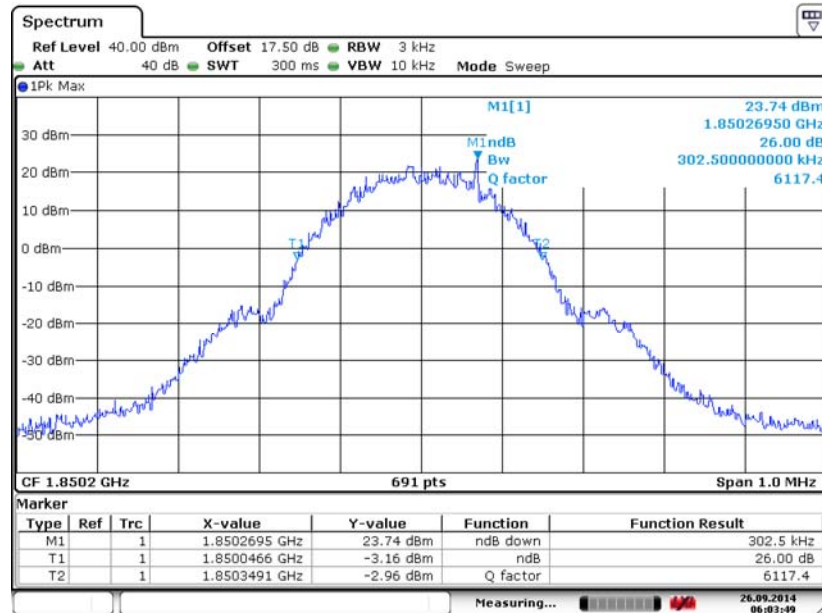

Date: 26.SEP.2014 06:03:50



99% Occupied Bandwidth Plot on Channel 661 (1880.0 MHz)

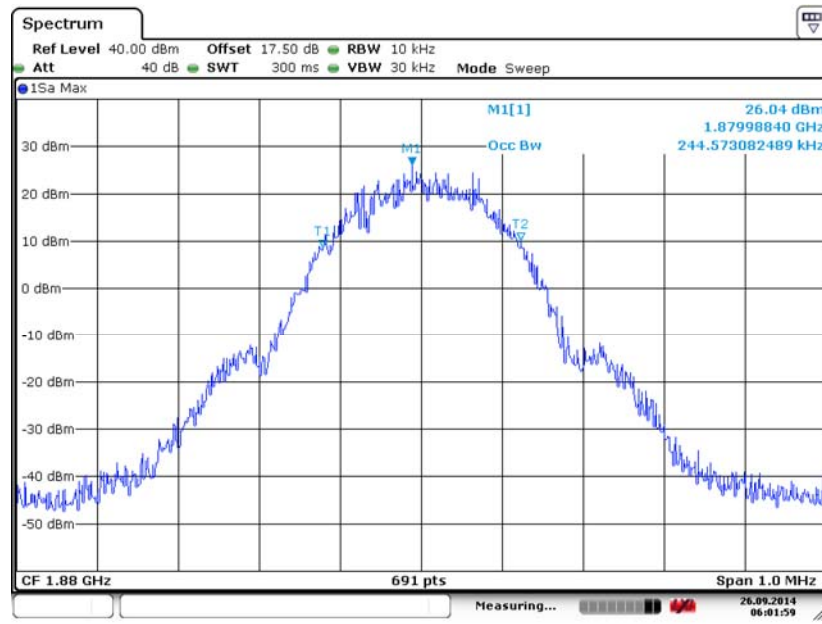

Date: 26.SEP.2014 06:02:00

26dB Bandwidth Plot on Channel 661 (1880.0 MHz)

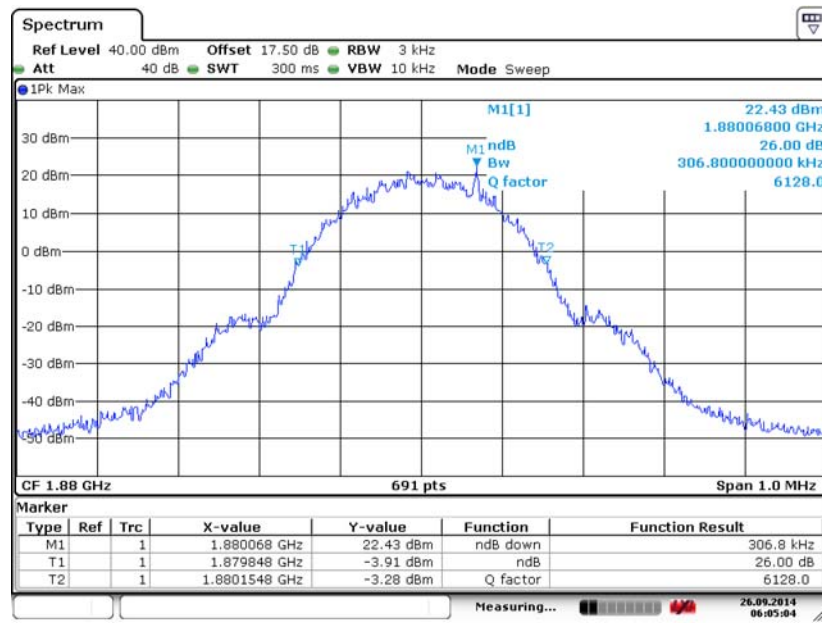

Date: 26.SEP.2014 06:05:04



99% Occupied Bandwidth Plot on Channel 810 (1909.8 MHz)

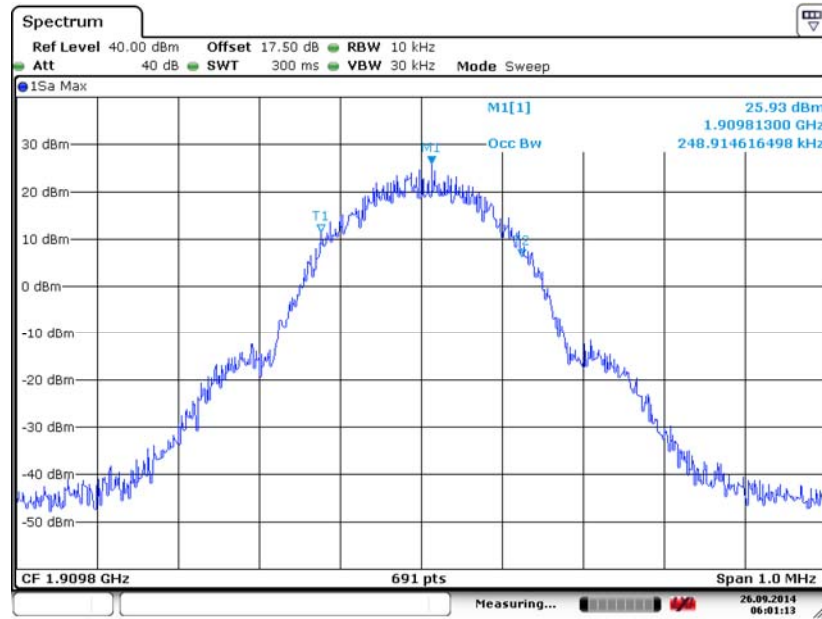

Date: 26.SEP.2014 06:01:14

26dB Bandwidth Plot on Channel 810 (1909.8 MHz)

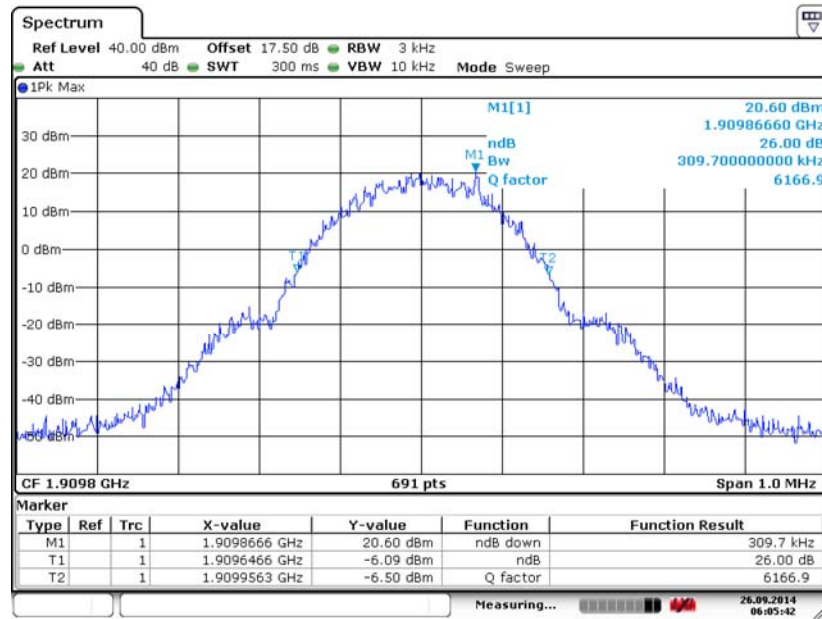

Date: 26.SEP.2014 06:05:42



Band :	GSM 1900	Test Mode :	EDGE class 8 Link (8PSK)
--------	----------	-------------	--------------------------

99% Occupied Bandwidth Plot on Channel 512 (1850.2 MHz)

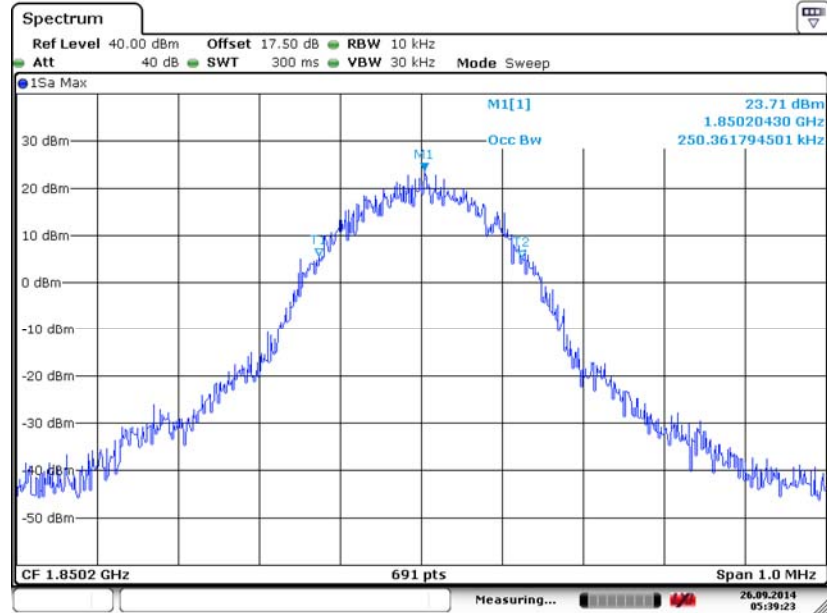

Date: 26.SEP.2014 05:39:23

26dB Bandwidth Plot on Channel 512 (1850.2 MHz)

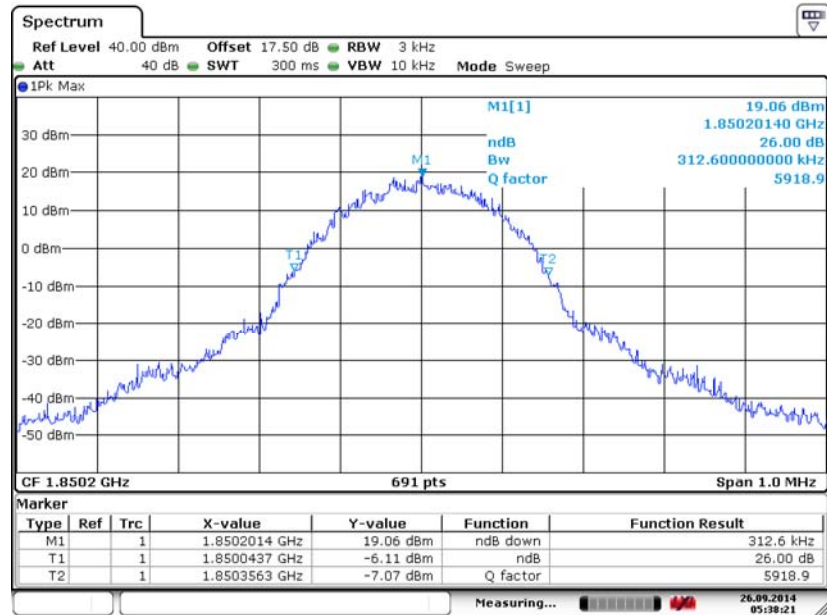

Date: 26.SEP.2014 05:38:21



99% Occupied Bandwidth Plot on Channel 661 (1880.0 MHz)

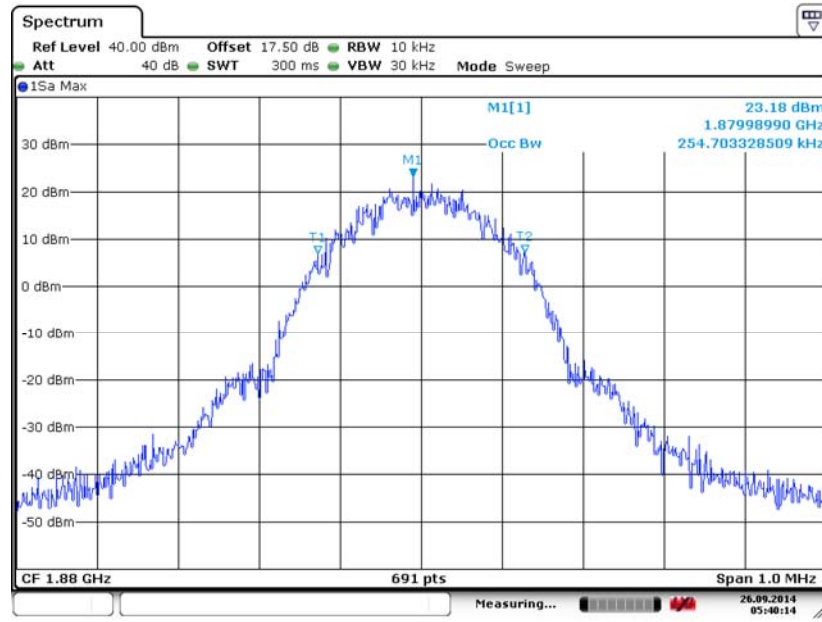

Date: 26.SEP.2014 05:40:14

26dB Bandwidth Plot on Channel 661 (1880.0 MHz)

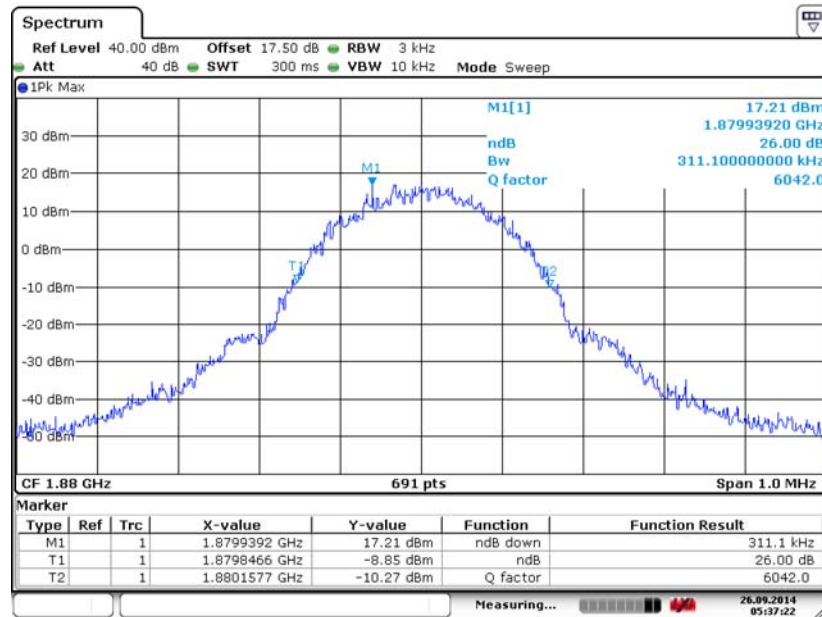

Date: 26.SEP.2014 05:37:22



99% Occupied Bandwidth Plot on Channel 810 (1909.8 MHz)

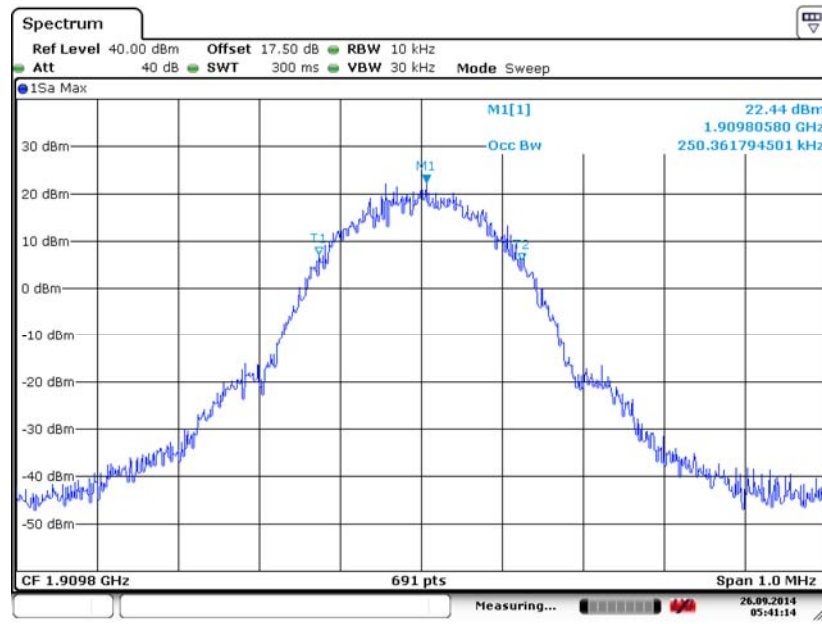

Date: 26.SEP.2014 05:41:14

26dB Bandwidth Plot on Channel 810 (1909.8 MHz)

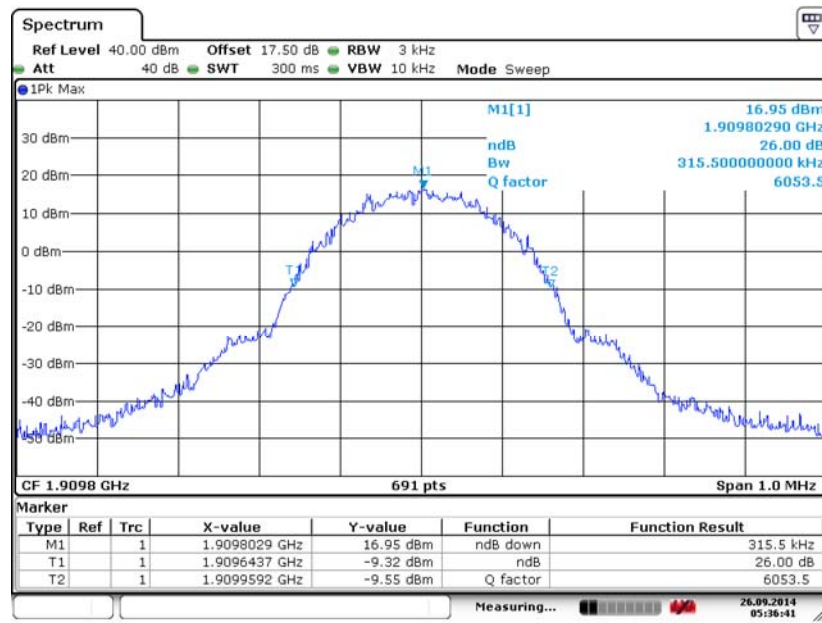

Date: 26.SEP.2014 05:36:41



Band :	WCDMA Band V	Test Mode :	RMC 12.2Kbps Link (QPSK)
--------	--------------	-------------	--------------------------

99% Occupied Bandwidth Plot on Channel 4132 (826.4 MHz)

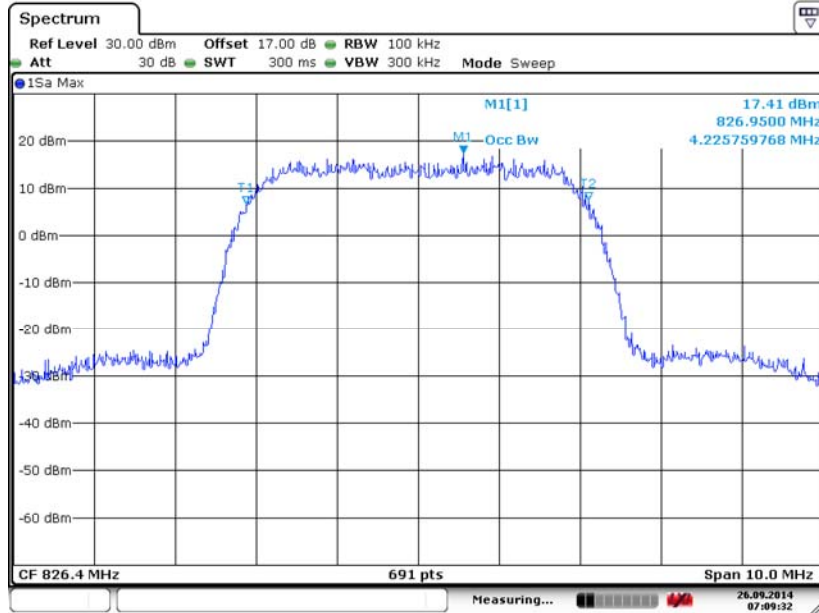

Date: 26.SEP.2014 07:09:32

26dB Bandwidth Plot on Channel 4132 (826.4 MHz)

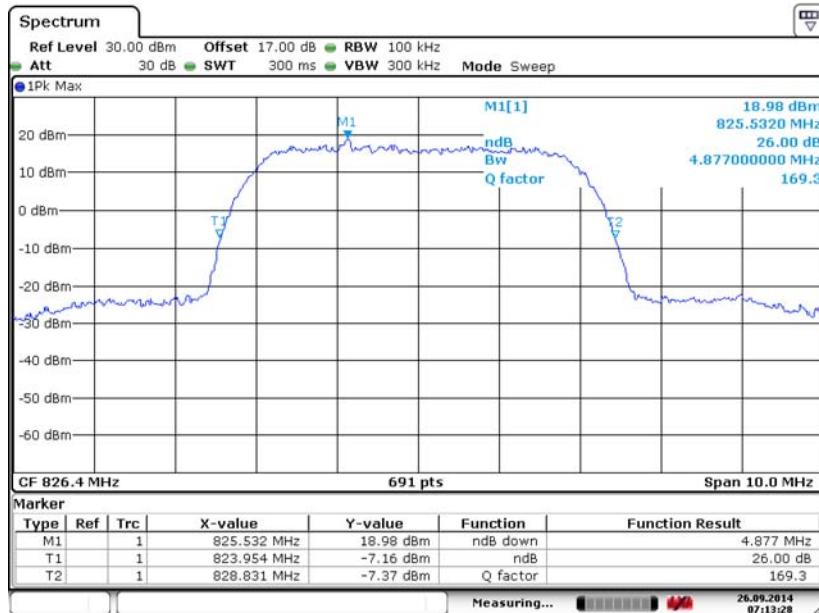

Date: 26.SEP.2014 07:13:29



99% Occupied Bandwidth Plot on Channel 4182 (836.4 MHz)

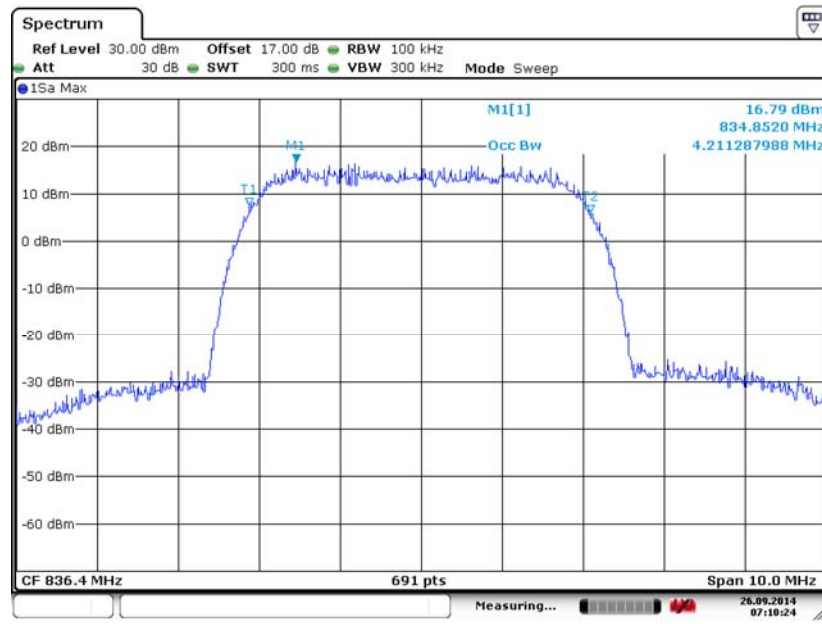

Date: 26.SEP.2014 07:10:24

26dB Bandwidth Plot on Channel 4182 (836.4 MHz)

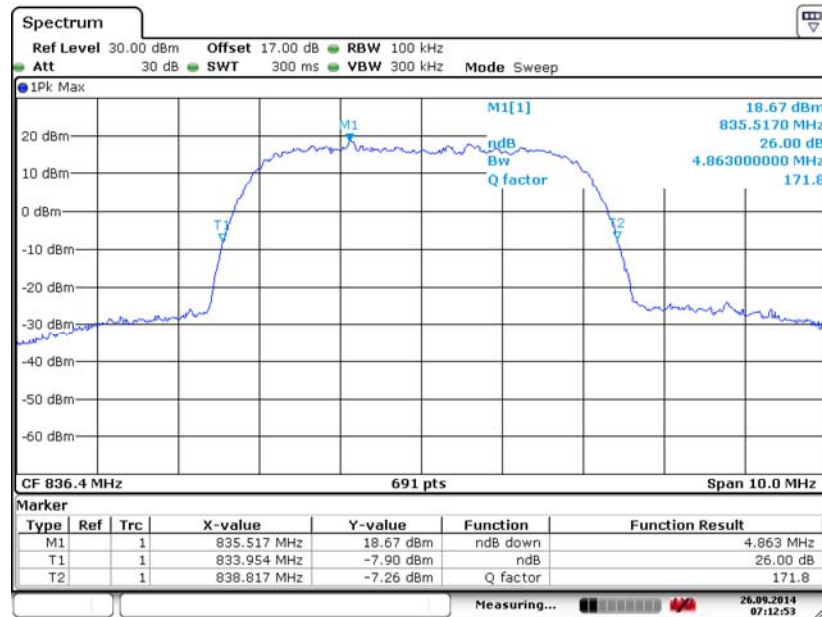

Date: 26.SEP.2014 07:12:53



99% Occupied Bandwidth Plot on Channel 4233 (846.6 MHz)

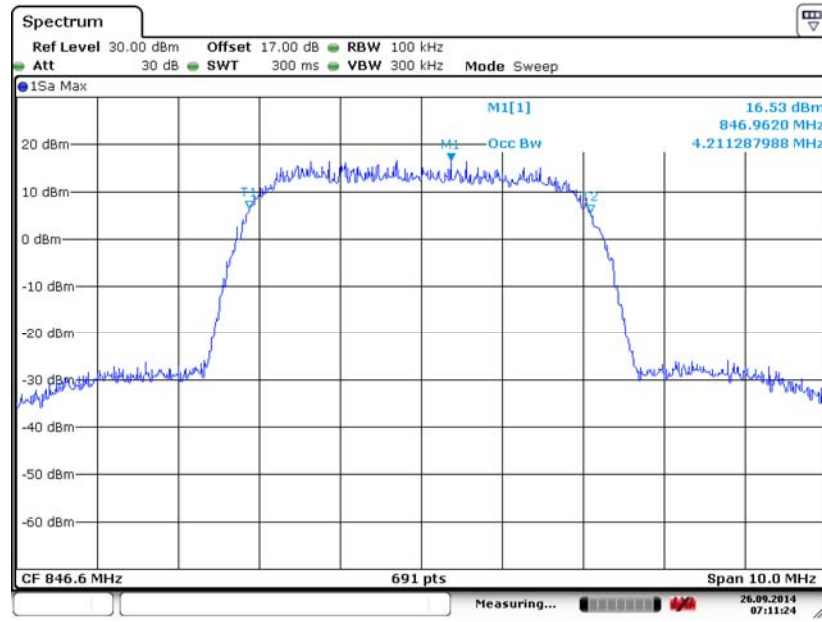

Date: 26.SEP.2014 07:11:24

26dB Bandwidth Plot on Channel 4233 (846.6 MHz)

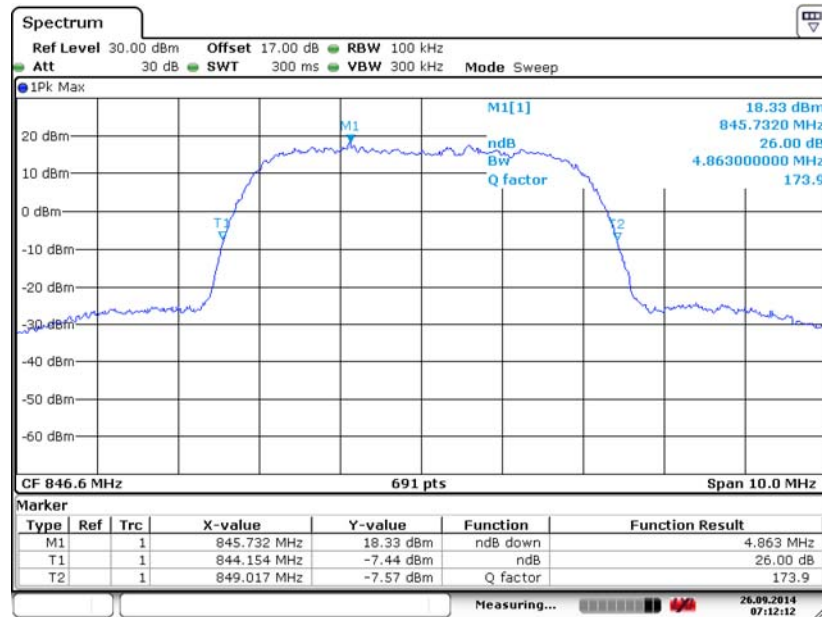

Date: 26.SEP.2014 07:12:12



Band :	WCDMA Band II	Test Mode :	RMC 12.2Kbps Link (QPSK)
--------	---------------	-------------	--------------------------

99% Occupied Bandwidth Plot on Channel 9262 (1852.4 MHz)

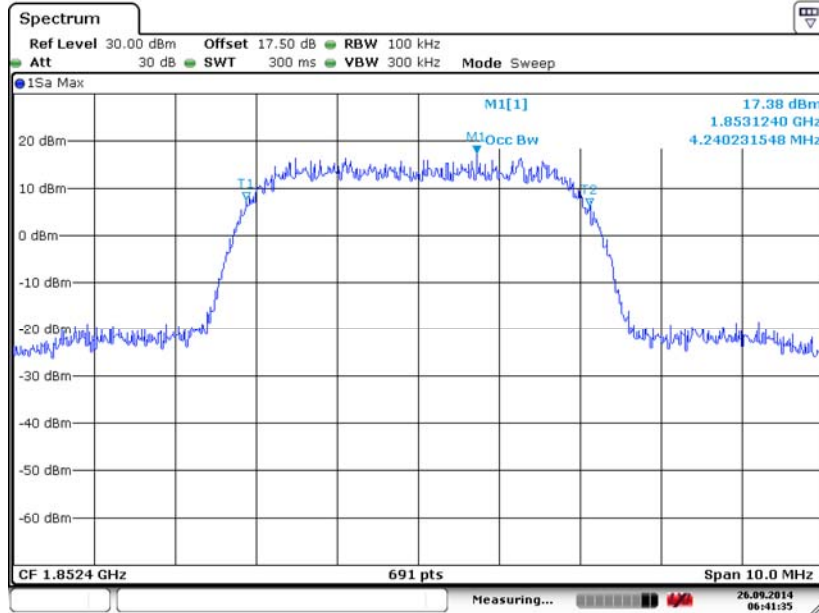

Date: 26.SEP.2014 06:41:35

26dB Bandwidth Plot on Channel 9262 (1852.4 MHz)

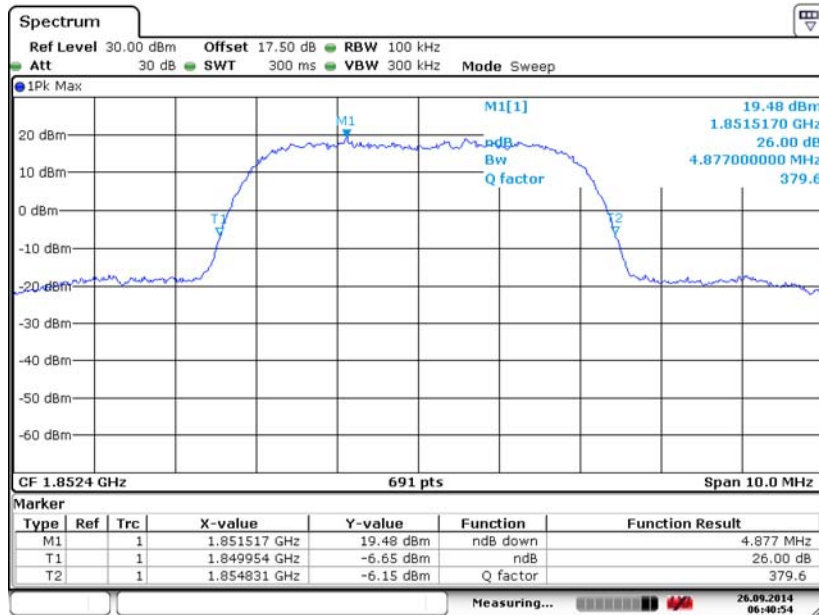

Date: 26.SEP.2014 06:40:55



99% Occupied Bandwidth Plot on Channel 9400 (1880.0 MHz)

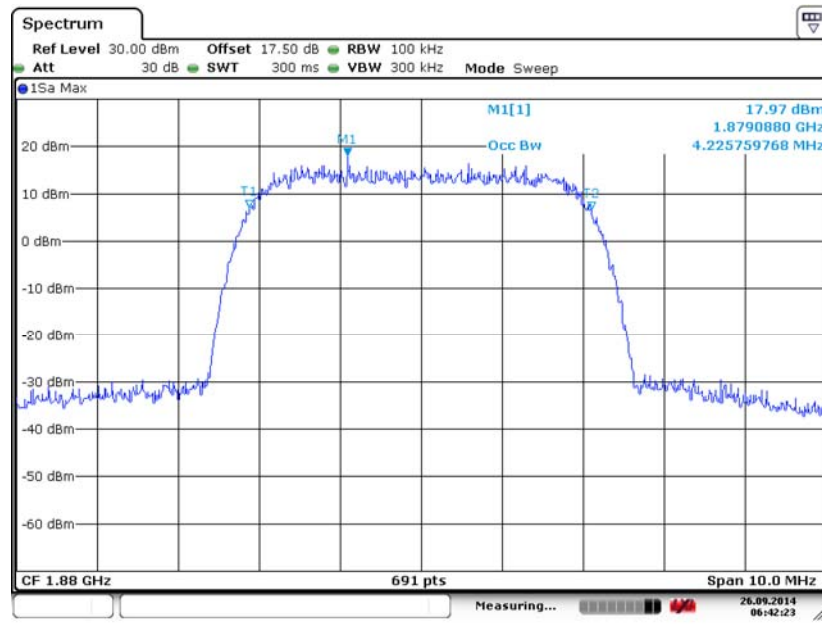

Date: 26.SEP.2014 06:42:23

26dB Bandwidth Plot on Channel 9400 (1880.0 MHz)

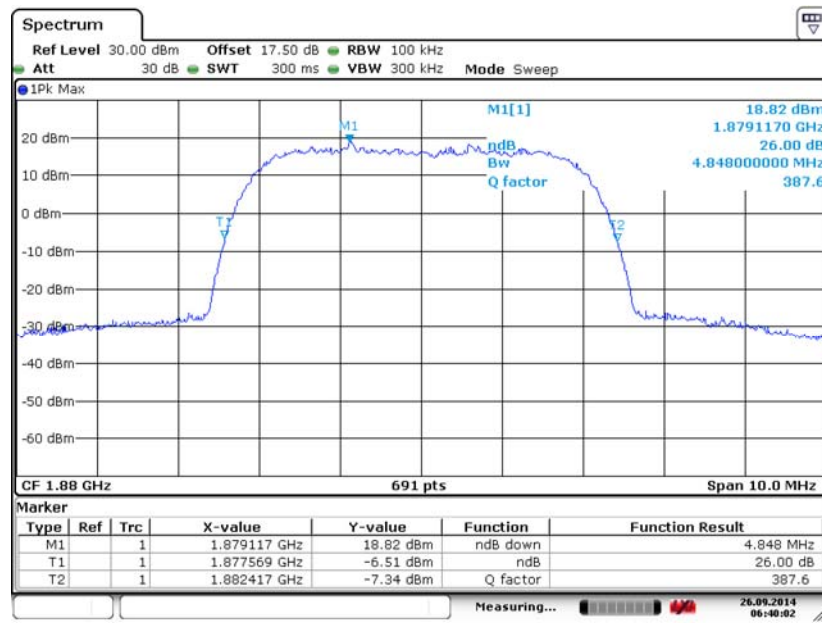

Date: 26.SEP.2014 06:40:02



99% Occupied Bandwidth Plot on Channel 9538 (1907.6 MHz)

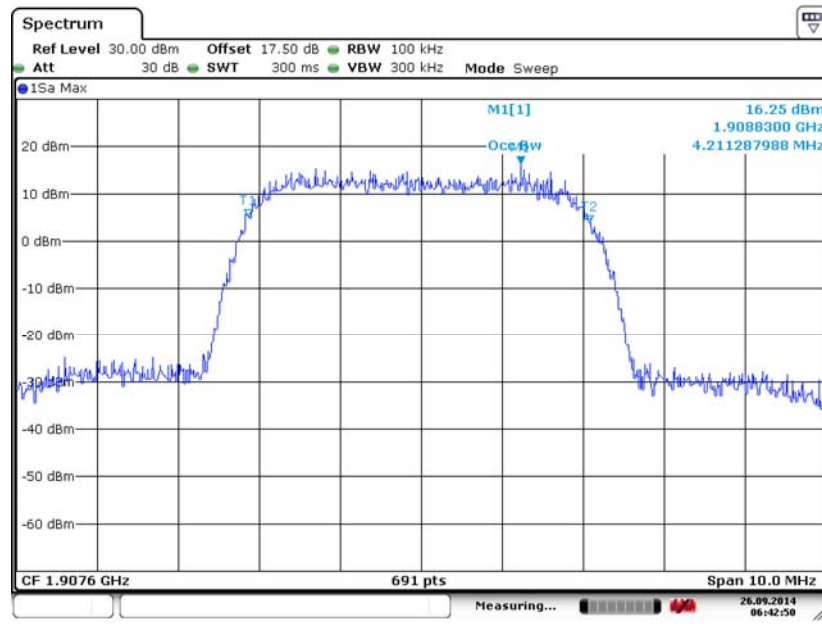

Date: 26.SEP.2014 06:42:50

26dB Bandwidth Plot on Channel 9538 (1907.6 MHz)

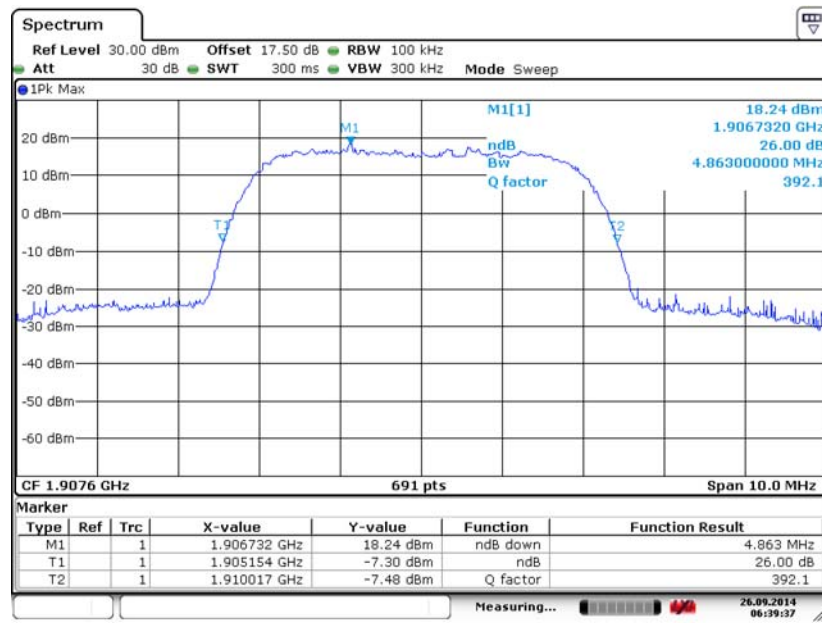

Date: 26.SEP.2014 06:39:37



3.5 Band Edge Measurement

3.5.1 Description of Band Edge Measurement

The power of any emission outside of the authorized operating frequency ranges must be lower than the transmitter power (P) by a factor of at least $43 + 10 \log (P)$ dB.

3.5.2 Measuring Instruments

The measuring equipment is listed in the section 4 of this test report.

3.5.3 Test Procedures

1. The testing follows FCC KDB 971168 v02r01 Section 6.0.
2. The EUT was connected to the spectrum analyzer and system simulator via a power divider.
3. The RF output of EUT was connected to the spectrum analyzer by an RF cable and attenuator. The path loss was compensated to the results for each measurement.
4. The band edges of low and high channels for the highest RF powers were measured.
5. The RF fundamental frequency should be excluded against the limit line in the operating frequency band.
6. The limit line is derived from $43 + 10\log(P)$ dB below the transmitter power P(Watts)
= $P(W) - [43 + 10\log(P)]$ (dB)
= $[30 + 10\log(P)]$ (dBm) - $[43 + 10\log(P)]$ (dB)
= -13dBm.

3.5.4 Test Setup

<Conducted Band Edge >

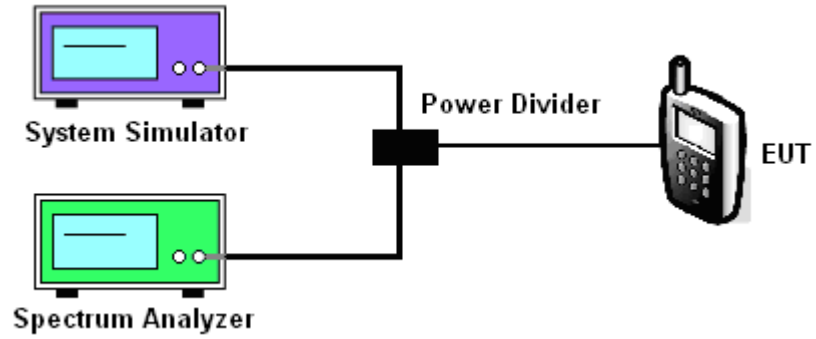

3.5.5 Test Result (Plots) of Conducted Band Edge

Band :	GSM850	Test Mode :	GSM Link (GMSK)
Correction Factor :	0.14dB	Maximum 26dB Bandwidth :	0.310MHz
Band Edge :	-16.29dBm	Measurement Value :	-16.43dBm

Lower Band Edge Plot on Channel 128 (824.2 MHz)

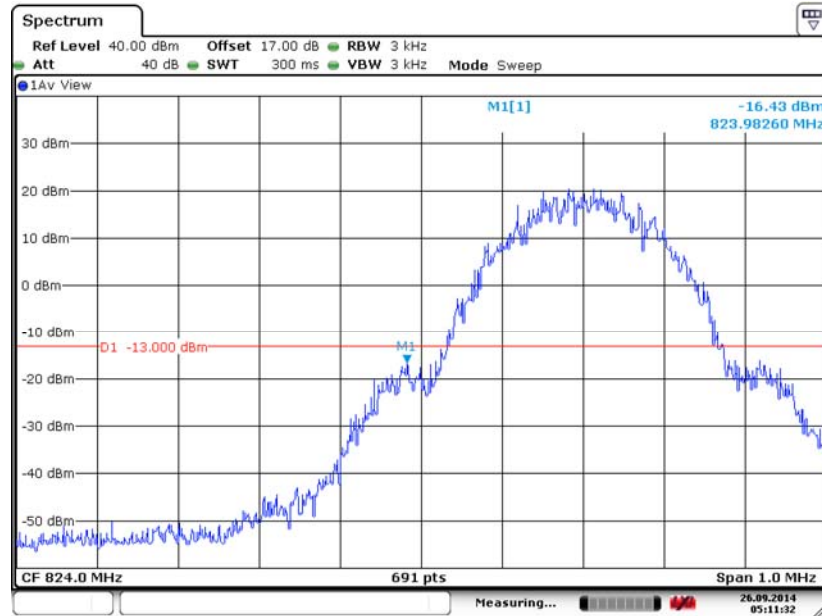

1. Correction Factor(dB)= $10\log(1\% \text{ Emission BW/RBW})$
2. Band Edge= Measurement Value + Correction Factor(dB)



Band :	GSM850	Test Mode :	GSM Link (GMSK)
Correction Factor :	0.14dB	Maximum 26dB Bandwidth :	0.310MHz
Band Edge :	-16.00dBm	Measurement Value :	-16.14dBm

Higher Band Edge Plot on Channel 251 (848.8 MHz)

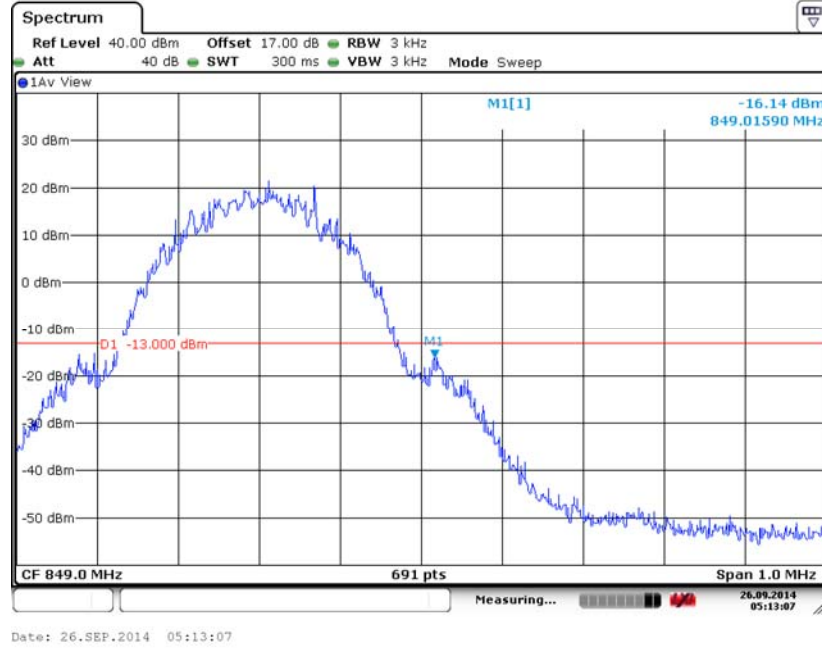

1. Correction Factor(dB)= $10\log(1\% \text{ Emission BW/RBW})$
2. Band Edge= Measurement Value + Correction Factor(dB)



Band :	GSM850	Test Mode :	EDGE class 8 Link (8PSK)
Correction Factor :	0.12dB	Maximum 26dB Bandwidth :	0.308MHz
Band Edge :	-23.93dBm	Measurement Value :	-24.05dBm

Lower Band Edge Plot on Channel 128 (824.2 MHz)

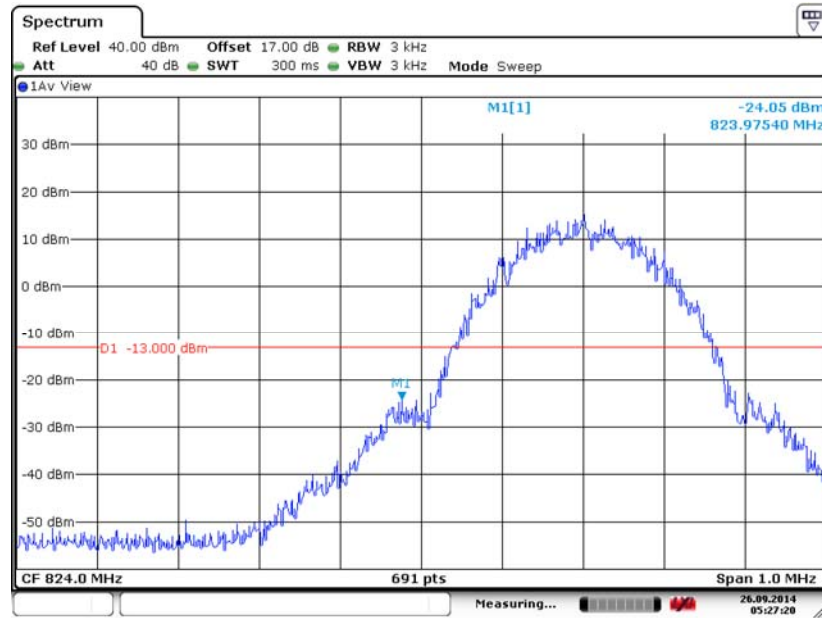

Date: 26.SEP.2014 05:27:21

1. Correction Factor(dB)= $10\log(1\% \text{ Emission BW/RBW})$
2. Band Edge= Measurement Value + Correction Factor(dB)



Band :	GSM850	Test Mode :	EDGE class 8 Link (8PSK)
Correction Factor :	0.12dB	Maximum 26dB Bandwidth :	0.308MHz
Band Edge :	-24.01dBm	Measurement Value :	-24.13dBm

Higher Band Edge Plot on Channel 251 (848.8 MHz)

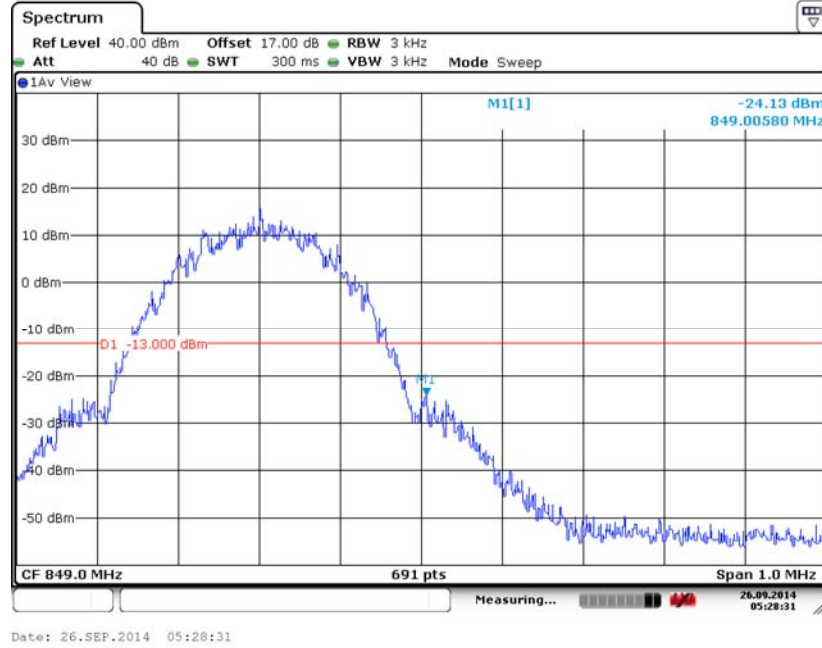

1. Correction Factor(dB)= $10\log(1\% \text{ Emission BW/RBW})$
2. Band Edge= Measurement Value + Correction Factor(dB)



Band :	GSM1900	Test Mode :	GSM Link (GMSK)
Correction Factor :	0.14dB	Maximum 26dB Bandwidth :	0.310MHz
Band Edge :	-17.64dBm	Measurement Value :	-17.78dBm

Lower Band Edge Plot on Channel 512 (1850.2 MHz)

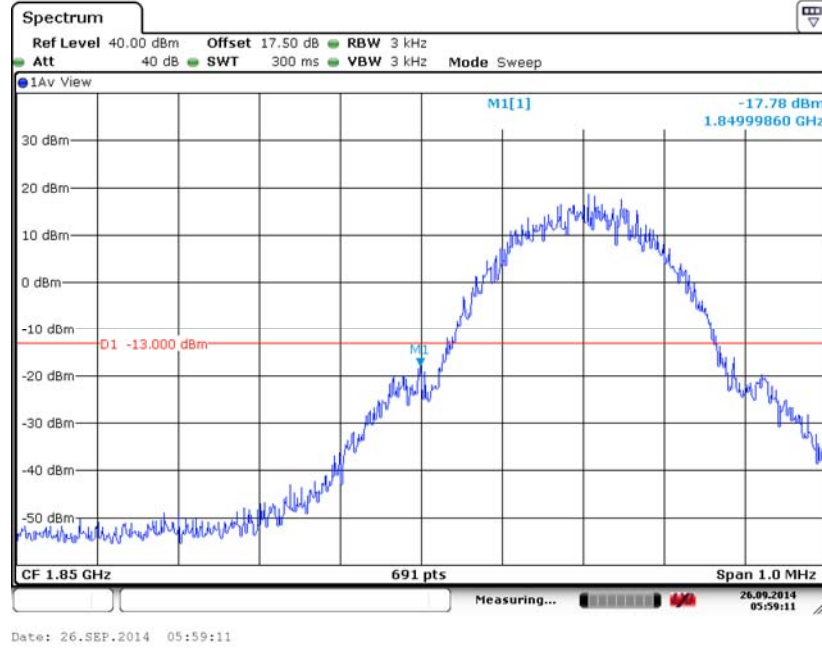

1. Correction Factor(dB)= $10\log(1\% \text{ Emission BW/RBW})$
2. Band Edge= Measurement Value + Correction Factor(dB)



Band :	GSM1900	Test Mode :	GSM Link (GMSK)
Correction Factor :	0.14dB	Maximum 26dB Bandwidth :	0.310MHz
Band Edge :	-20.57dBm	Measurement Value :	-20.71dBm

Higher Band Edge Plot on Channel 810 (1909.8 MHz)

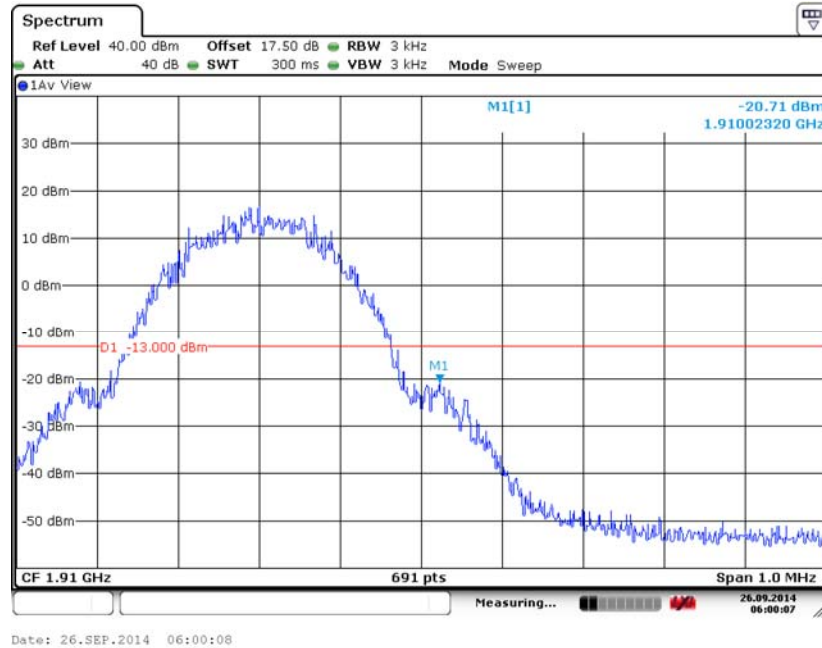

1. Correction Factor(dB)= $10\log(1\% \text{ Emission BW/RBW})$
2. Band Edge= Measurement Value + Correction Factor(dB)



Band :	GSM1900	Test Mode :	EDGE class 8 Link (8PSK)
Correction Factor :	0.22dB	Maximum 26dB Bandwidth :	0.316MHz
Band Edge :	-24.17dBm	Measurement Value :	-24.39dBm

Lower Band Edge Plot on Channel 512 (1850.2 MHz)

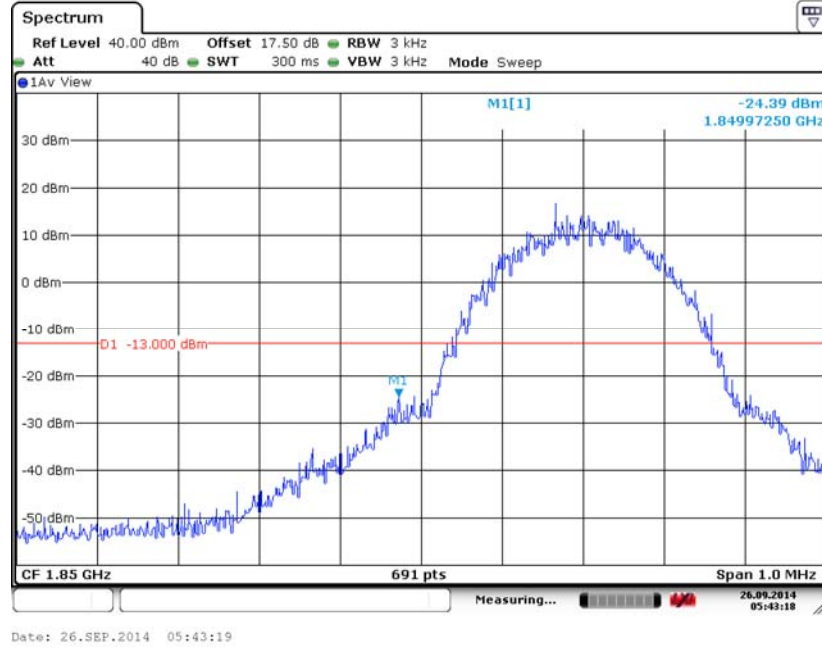

1. Correction Factor(dB)= $10\log(1\% \text{ Emission BW/RBW})$
2. Band Edge= Measurement Value + Correction Factor(dB)



Band :	GSM1900	Test Mode :	EDGE class 8 Link (8PSK)
Correction Factor :	0.22dB	Maximum 26dB Bandwidth :	0.316MHz
Band Edge :	-25.45dBm	Measurement Value :	-25.67dBm

Higher Band Edge Plot on Channel 810 (1909.8 MHz)

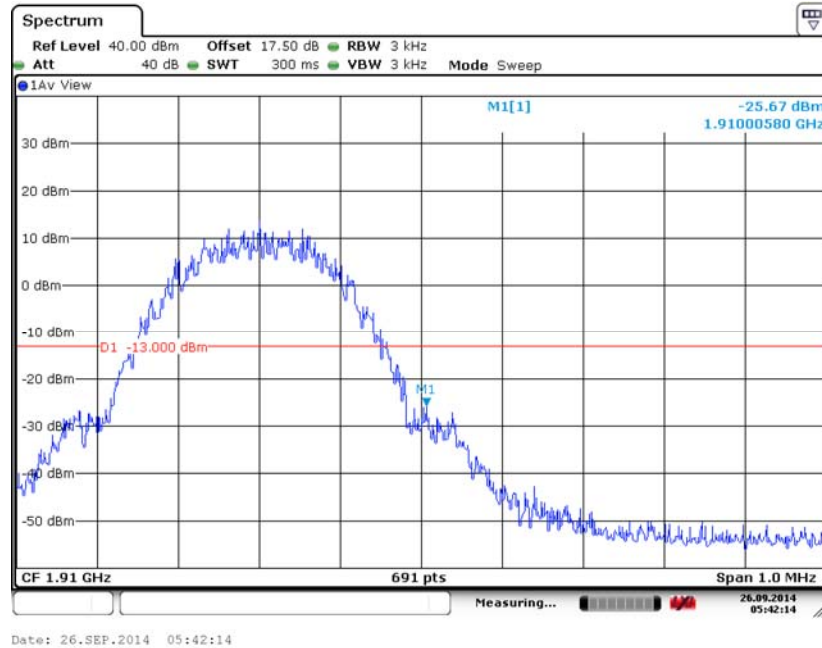

1. Correction Factor(dB)= $10\log(1\% \text{ Emission BW/RBW})$
2. Band Edge= Measurement Value + Correction Factor(dB)



Band :	WCDMA Band V	Test Mode :	RMC 12.2Kbps Link (QPSK)
Correction Factor :	-3.12dB	Maximum 26dB Bandwidth :	4.880MHz
Band Edge :	-18.38dBm	Measurement Value :	-15.26dBm

Lower Band Edge Plot on Channel 4132 (826.4 MHz)

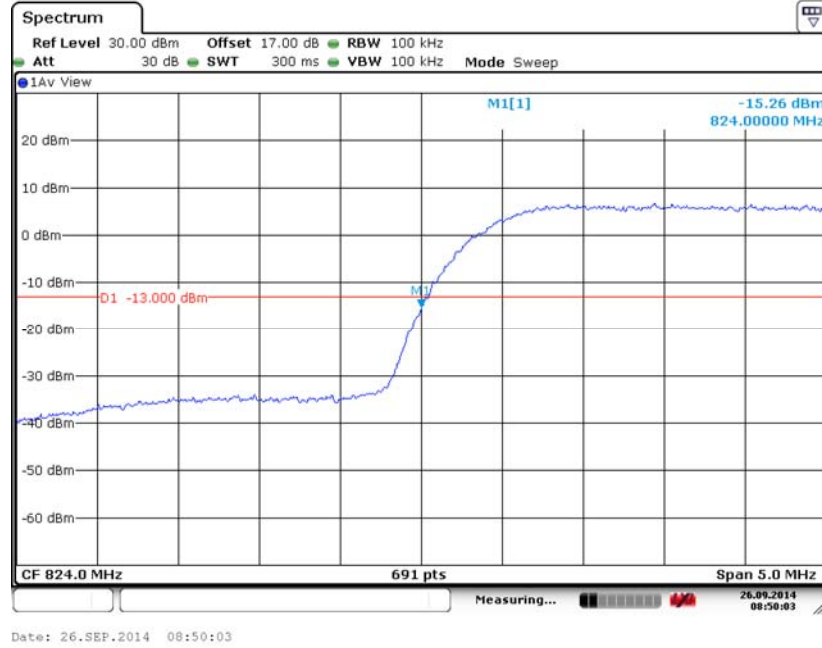

1. Correction Factor(dB)= $10\log(1\% \text{ Emission BW/RBW})$
2. Band Edge= Measurement Value + Correction Factor(dB)



Band :	WCDMA Band V	Test Mode :	RMC 12.2Kbps Link (QPSK)
Correction Factor :	-3.12dB	Maximum 26dB Bandwidth :	4.880MHz
Band Edge :	-20.00dBm	Measurement Value :	-16.88dBm

Higher Band Edge Plot on Channel 4233 (846.6 MHz)

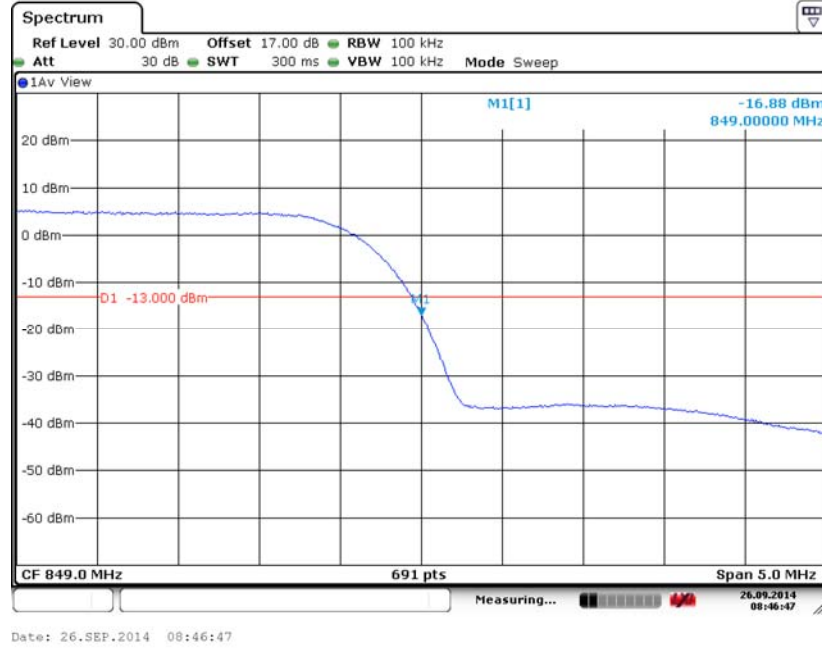

1. Correction Factor(dB)= $10\log(1\% \text{ Emission BW/RBW})$
2. Band Edge= Measurement Value + Correction Factor(dB)



Band :	WCDMA Band II	Test Mode :	RMC 12.2Kbps Link (QPSK)
Correction Factor :	-3.12dB	Maximum 26dB Bandwidth :	4.880MHz
Band Edge :	-17.43dBm	Measurement Value :	-14.31dBm

Lower Band Edge Plot on Channel 9262 (1852.4 MHz)

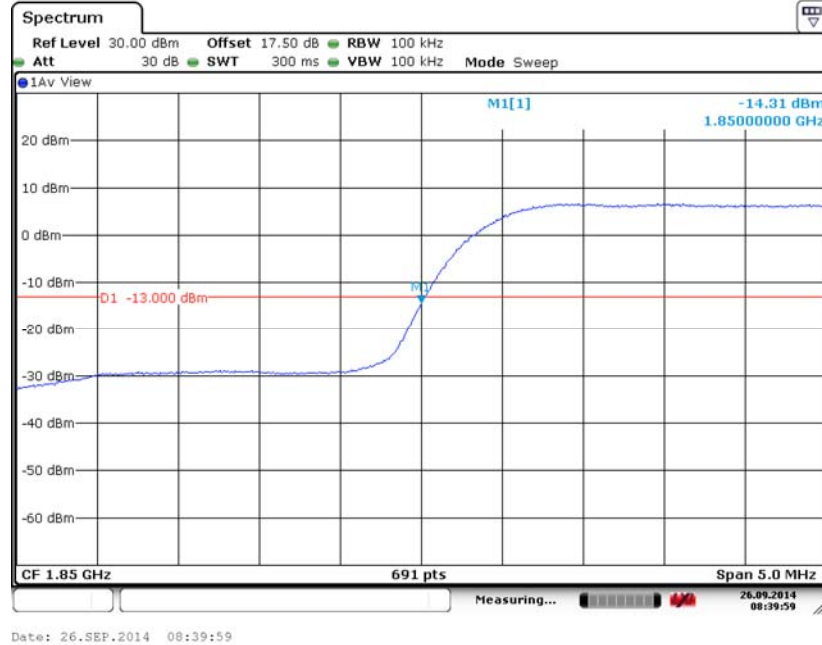

1. Correction Factor(dB)= $10\log(1\% \text{ Emission BW/RBW})$
2. Band Edge= Measurement Value + Correction Factor(dB)



Band :	WCDMA Band II	Test Mode :	RMC 12.2Kbps Link (QPSK)
Correction Factor :	-3.12dB	Maximum 26dB Bandwidth :	4.880MHz
Band Edge :	-19.77dBm	Measurement Value :	-16.65dBm

Higher Band Edge Plot on Channel 9538 (1907.6 MHz)

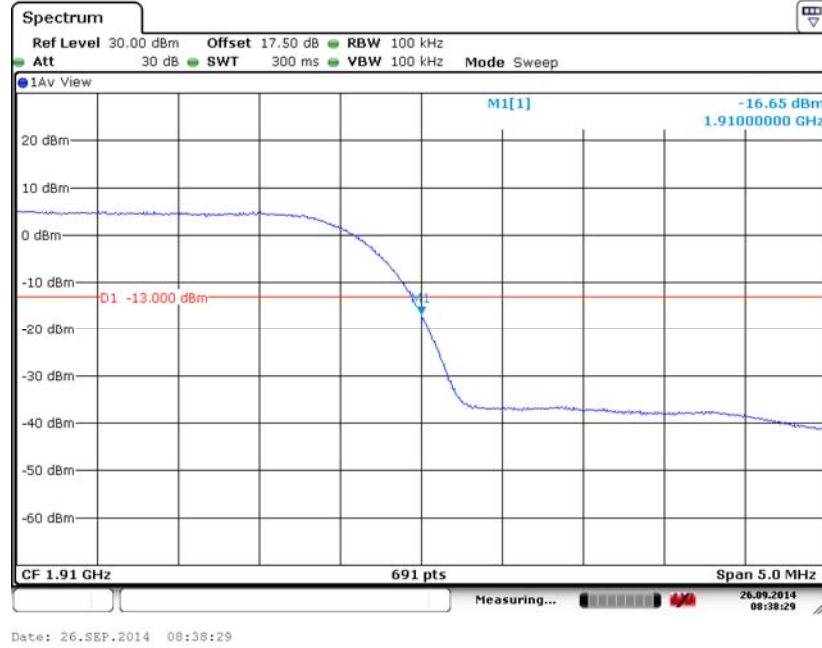

1. Correction Factor(dB)= $10\log(1\% \text{ Emission BW/RBW})$
2. Band Edge= Measurement Value + Correction Factor(dB)

3.6 Conducted Spurious Emission Measurement

3.6.1 Description of Conducted Spurious Emission Measurement

The power of any emission outside of the authorized operating frequency ranges must be lower than the transmitter power (P) by a factor of at least $43 + 10 \log (P)$ dB.

It is measured by means of a calibrated spectrum analyzer and scanned from 30 MHz up to a frequency including its 10th harmonic.

3.6.2 Measuring Instruments

The measuring equipment is listed in the section 4 of this test report.

3.6.3 Test Procedures

1. The testing follows FCC KDB 971168 v02r01 Section 6.0.
2. The EUT was connected to the spectrum analyzer and system simulator via a power divider.
3. The RF output of EUT was connected to the spectrum analyzer by an RF cable and attenuator. The path loss was compensated to the results for each measurement.
4. The middle channel for the highest RF power within the transmitting frequency was measured.
5. The conducted spurious emission for the whole frequency range was taken.
6. The RF fundamental frequency should be excluded against the limit line in the operating frequency band.
7. The limit line is derived from $43 + 10\log(P)$ dB below the transmitter power P(Watts)
= $P(W) - [43 + 10\log(P)]$ (dB)
= $[30 + 10\log(P)]$ (dBm) - $[43 + 10\log(P)]$ (dB)
= -13dBm.

3.6.4 Test Setup

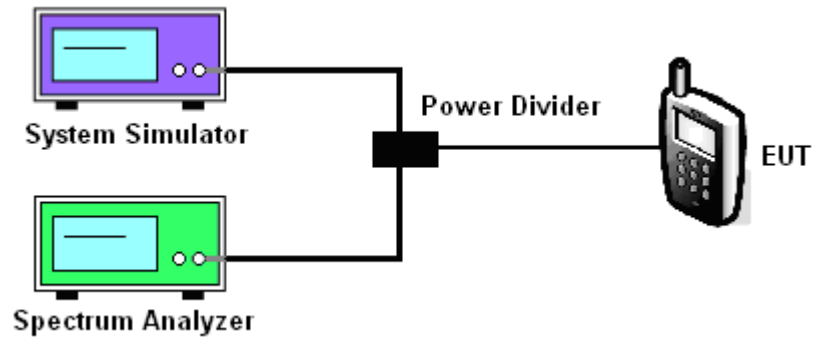



3.6.5 Test Result (Plots) of Conducted Spurious Emission

Band :	GSM850	Channel :	CH189
Test Mode :	GSM Link (GMSK)	Frequency :	836.4 MHz

Conducted Spurious Emission Plot between 30MHz ~ 1GHz

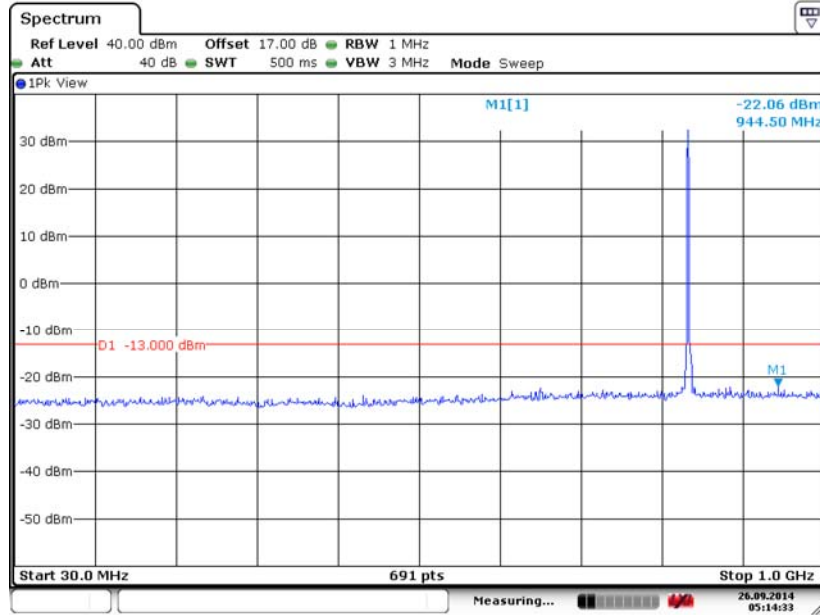

Conducted Spurious Emission Plot between 1GHz ~ 3GHz

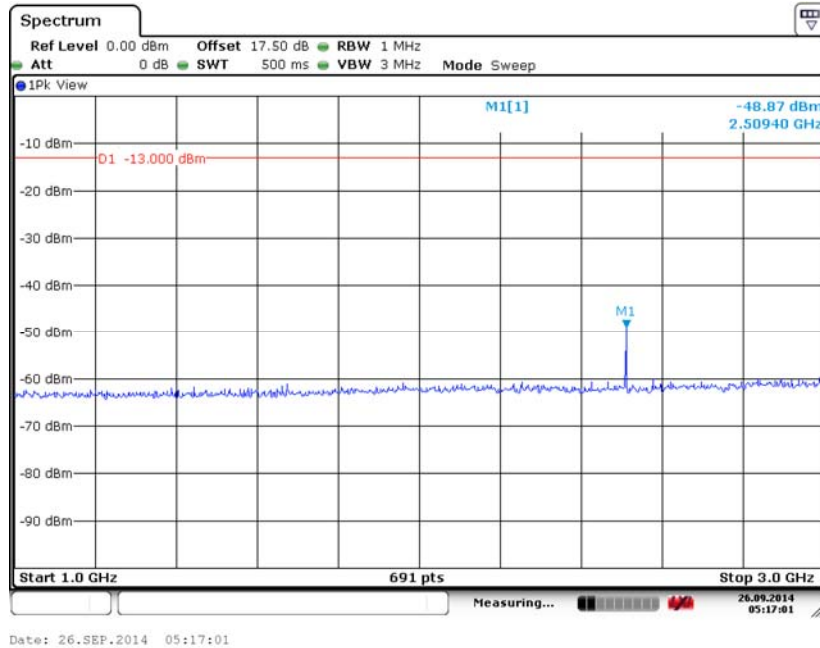



Conducted Spurious Emission Plot between 3GHz ~ 7GHz

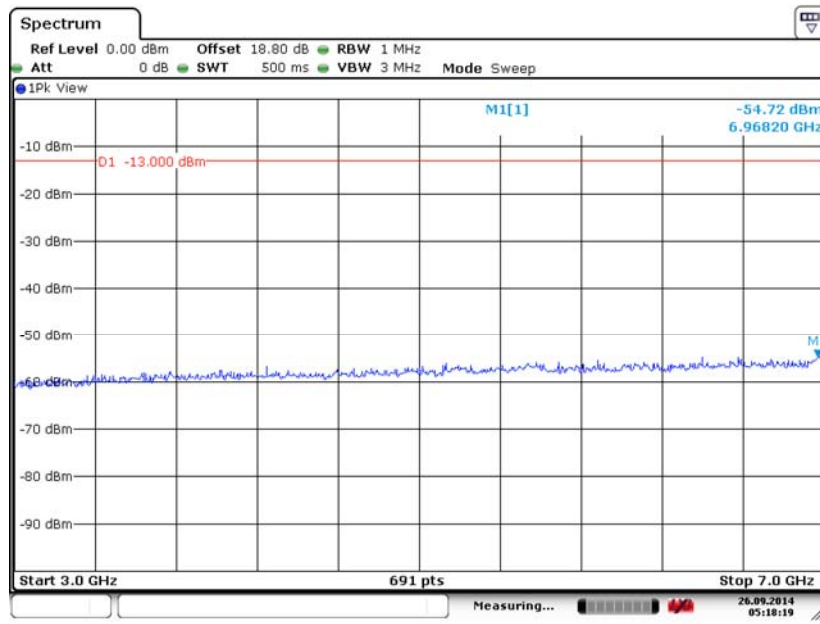

Date: 26.SEP.2014 05:18:20

Conducted Spurious Emission Plot between 7GHz ~ 9GHz

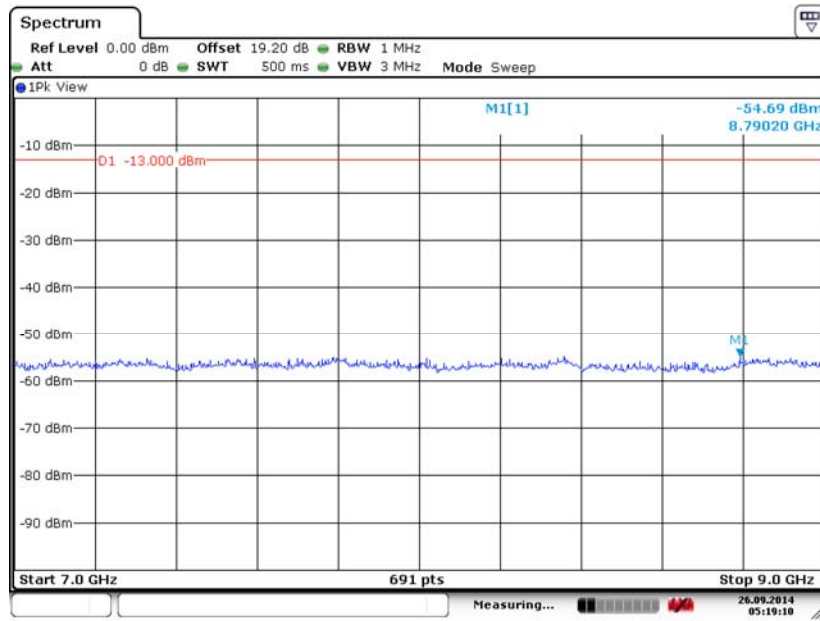

Date: 26.SEP.2014 05:19:11



Band :	GSM850	Channel :	CH189
Test Mode :	EDGE class 8 Link (8PSK)	Frequency :	836.4 MHz

Conducted Spurious Emission Plot between 30MHz ~ 1GHz

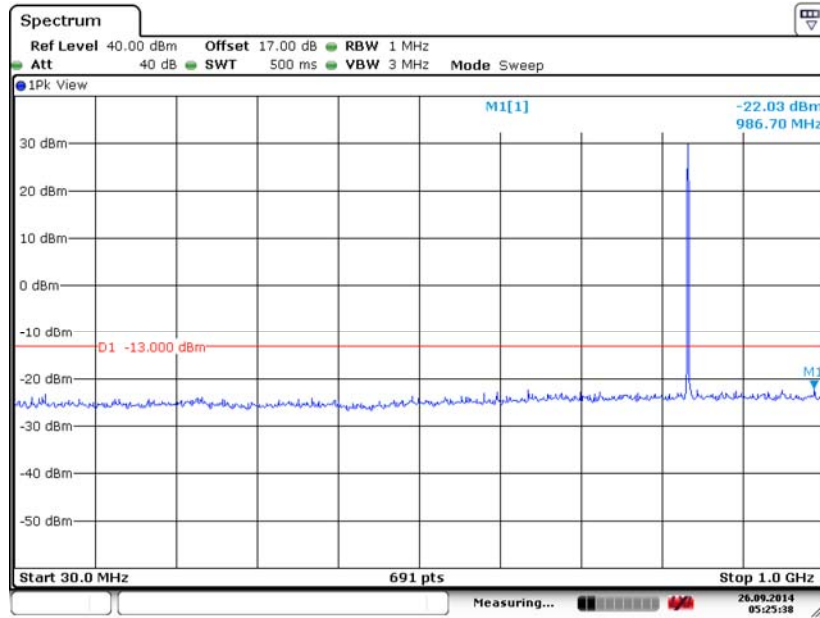

Date: 26.SEP.2014 05:25:38

Conducted Spurious Emission Plot between 1GHz ~ 3GHz

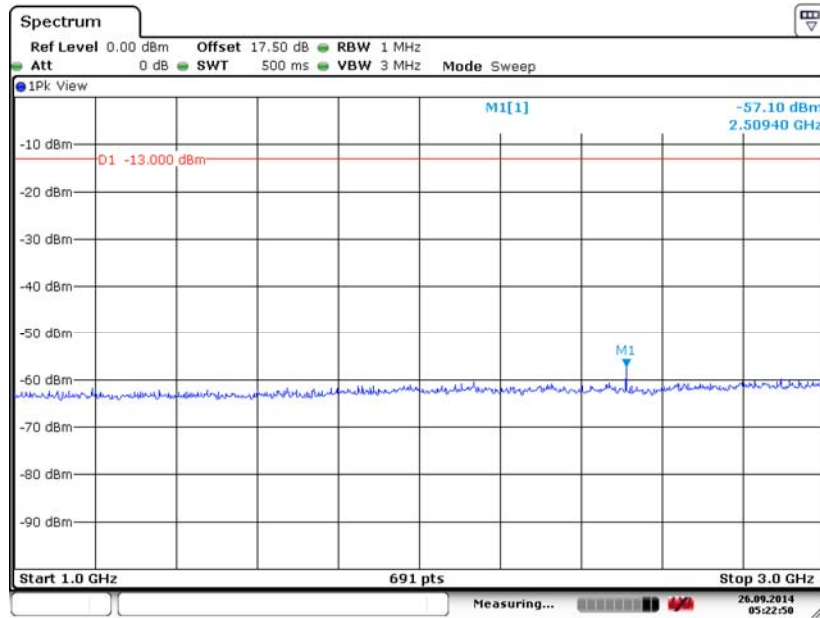

Date: 26.SEP.2014 05:22:58



Conducted Spurious Emission Plot between 3GHz ~ 7GHz

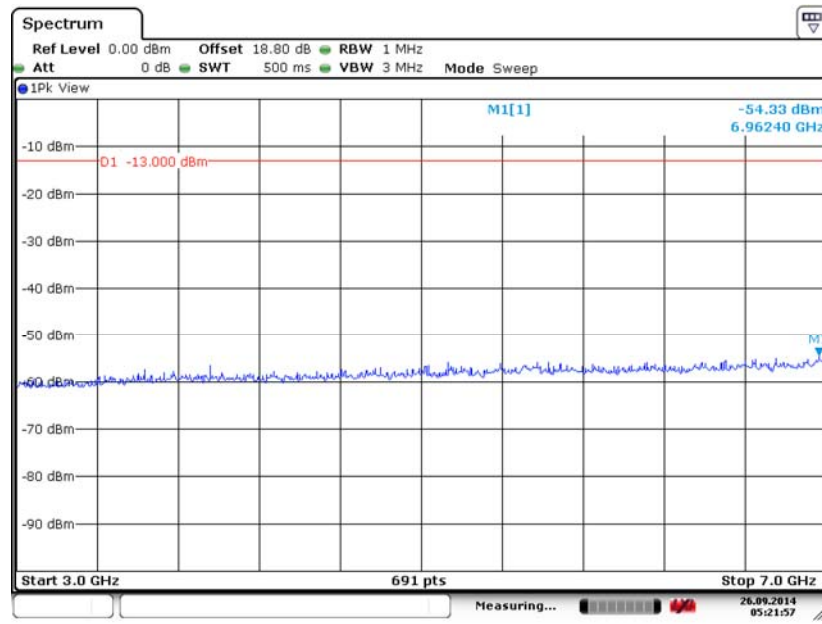

Date: 26.SEP.2014 05:21:57

Conducted Spurious Emission Plot between 7GHz ~ 9GHz

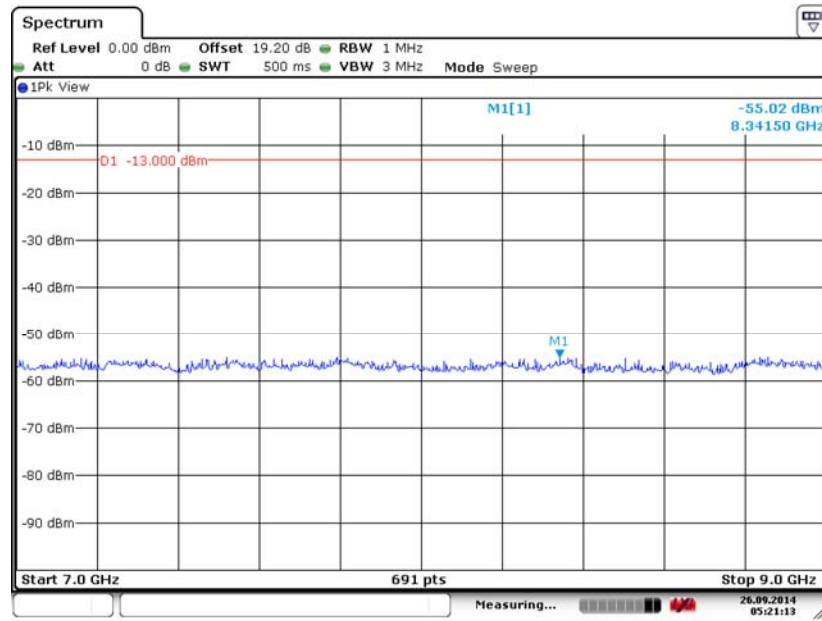

Date: 26.SEP.2014 05:21:13



Band :	GSM1900	Channel :	CH661
Test Mode :	GSM Link (GMSK)	Frequency :	1880.0 MHz

Conducted Spurious Emission Plot between 30MHz ~ 1GHz

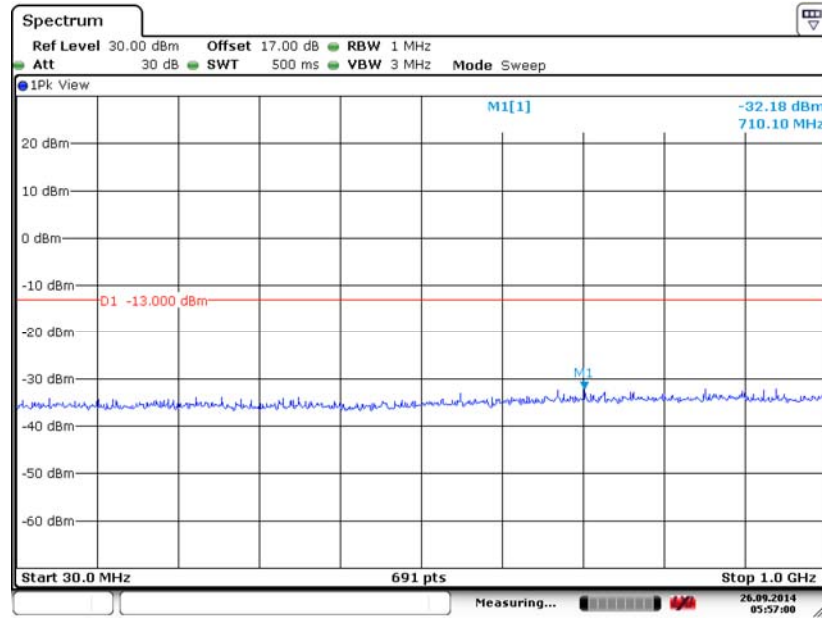

Date: 26.SEP.2014 05:57:00

Conducted Spurious Emission Plot between 1GHz ~ 3GHz

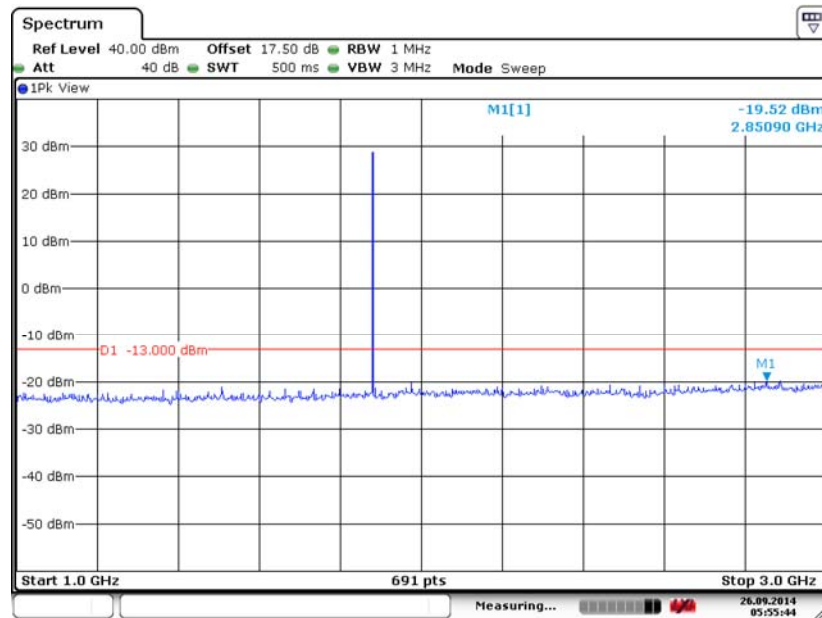

Date: 26.SEP.2014 05:55:44



Conducted Spurious Emission Plot between 3GHz ~ 7GHz

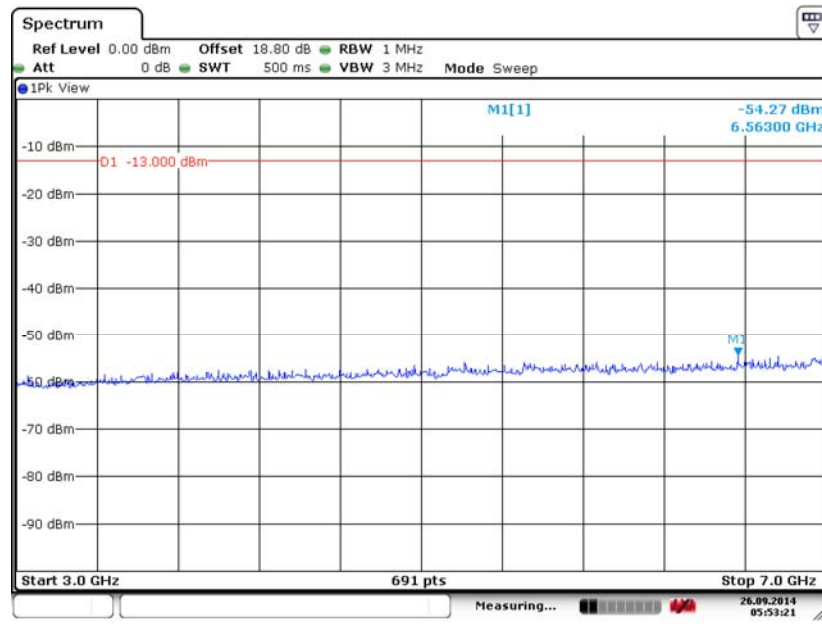

Date: 26.SEP.2014 05:53:22

Conducted Spurious Emission Plot between 7GHz ~ 13.6GHz

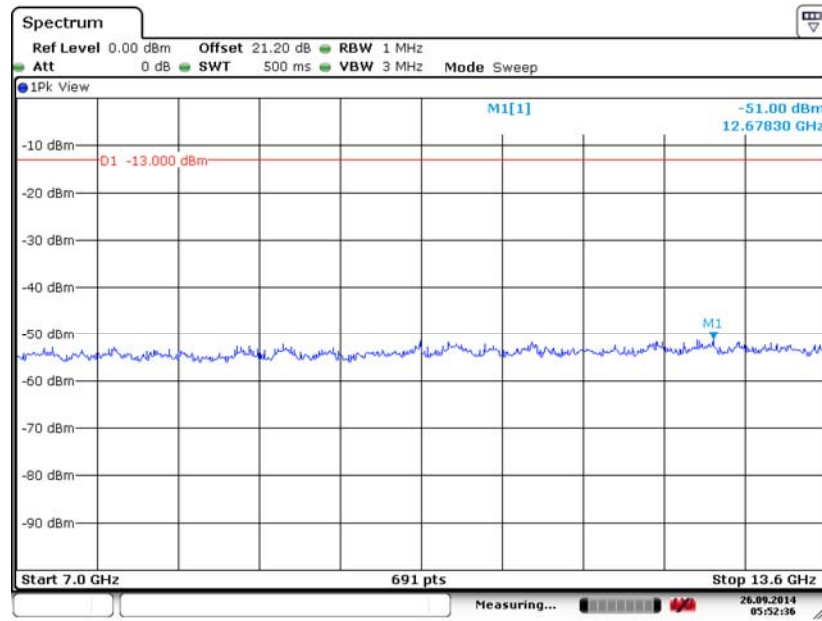

Date: 26.SEP.2014 05:52:36



Conducted Spurious Emission Plot between 13.6GHz ~ 19.1GHz

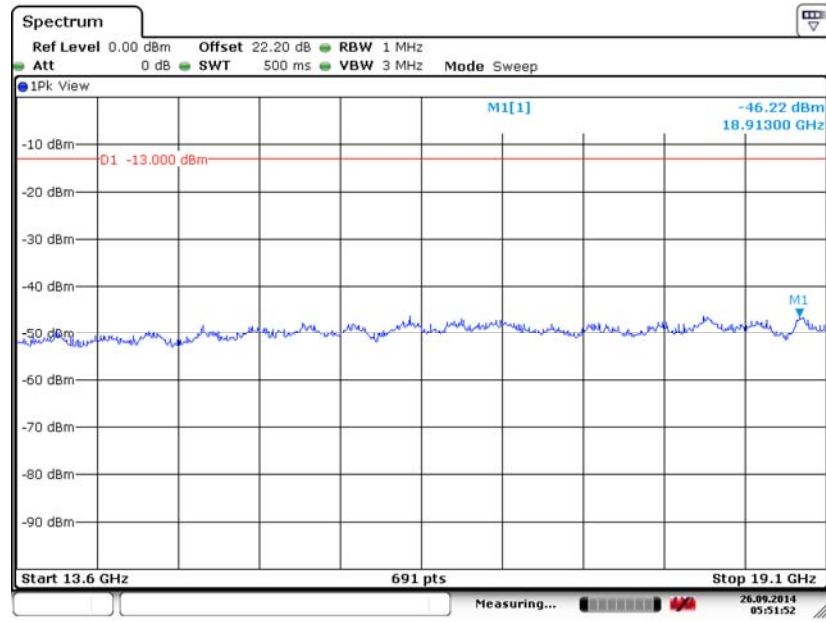

Date: 26.SEP.2014 05:51:53



Band :	GSM1900	Channel :	CH661
Test Mode :	EDGE class 8 Link (8PSK)	Frequency :	1880.0 MHz

Conducted Spurious Emission Plot between 30MHz ~ 1GHz

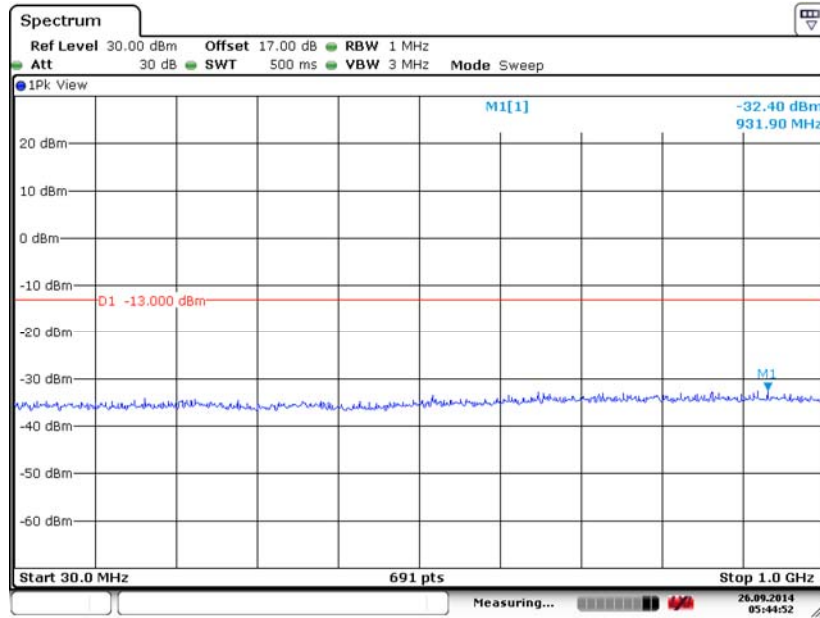

Date: 26.SEP.2014 05:44:53

Conducted Spurious Emission Plot between 1GHz ~ 3GHz

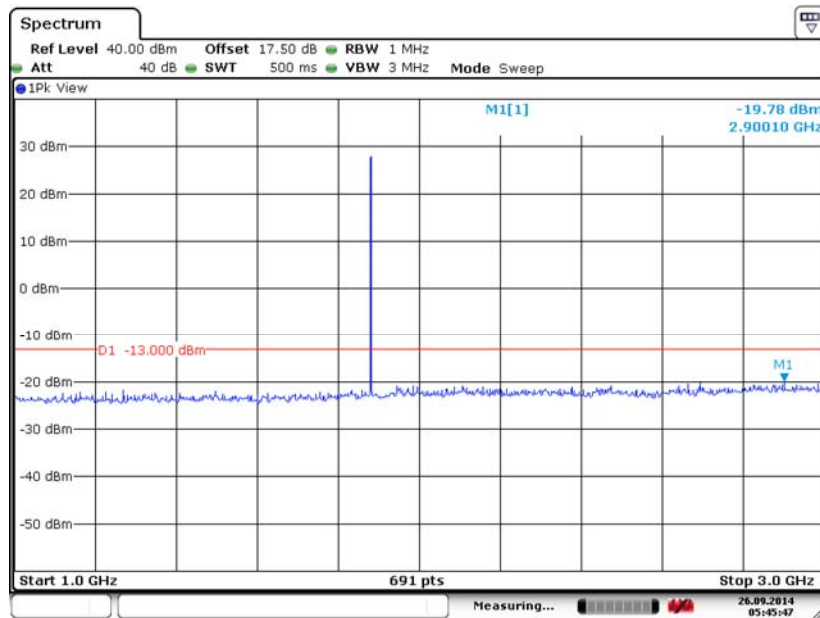

Date: 26.SEP.2014 05:45:48



Conducted Spurious Emission Plot between 3GHz ~ 7GHz

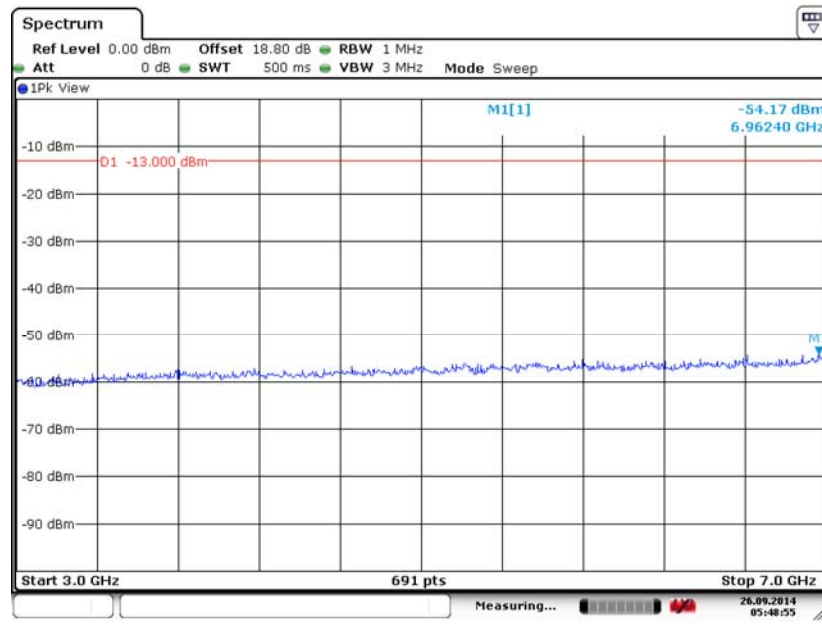

Date: 26.SEP.2014 05:48:56

Conducted Spurious Emission Plot between 7GHz ~ 13.6GHz

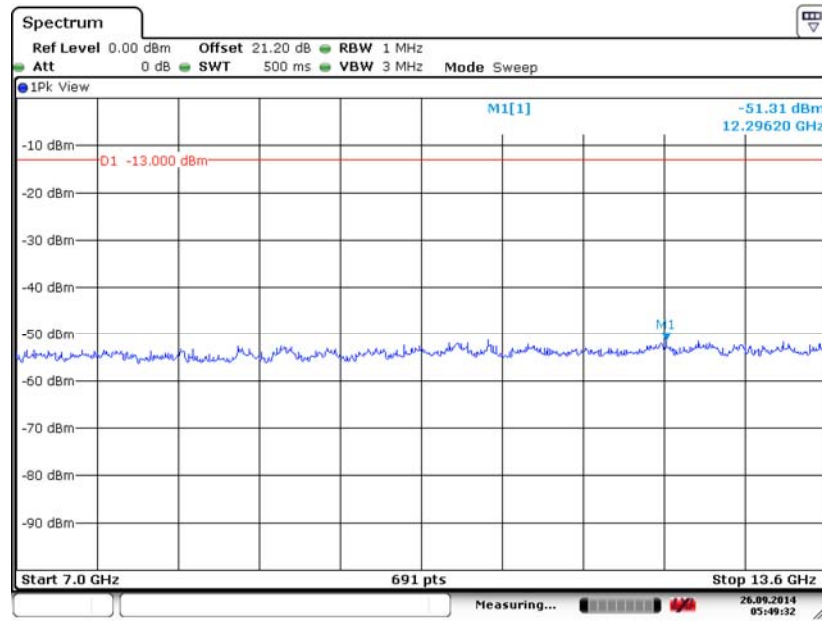

Date: 26.SEP.2014 05:49:32



Conducted Spurious Emission Plot between 13.6GHz ~ 19.1GHz

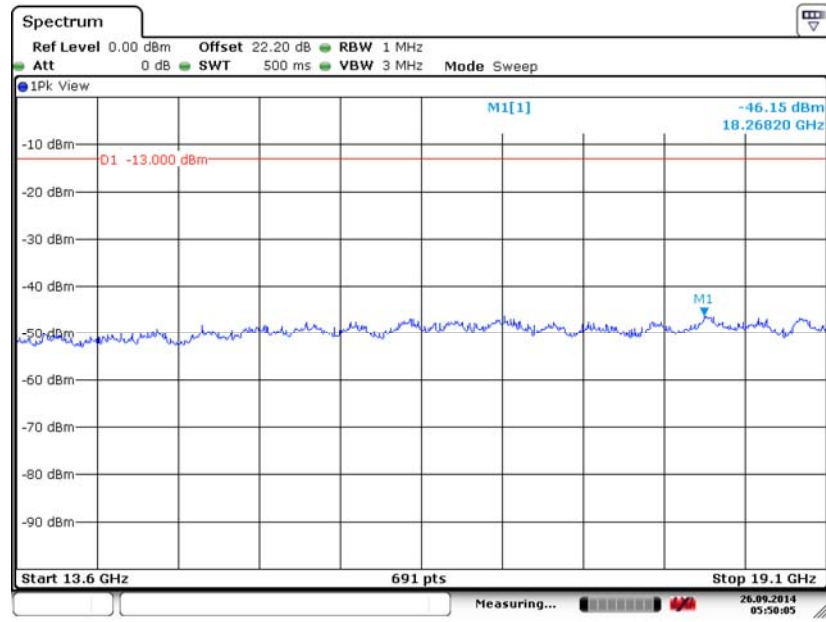

Date: 26.SEP.2014 05:50:06



Band :	WCDMA Band V	Channel :	CH4182
Test Mode :	RMC 12.2Kbps Link (QPSK)	Frequency :	836.4 MHz

Conducted Spurious Emission Plot between 30MHz ~ 1GHz

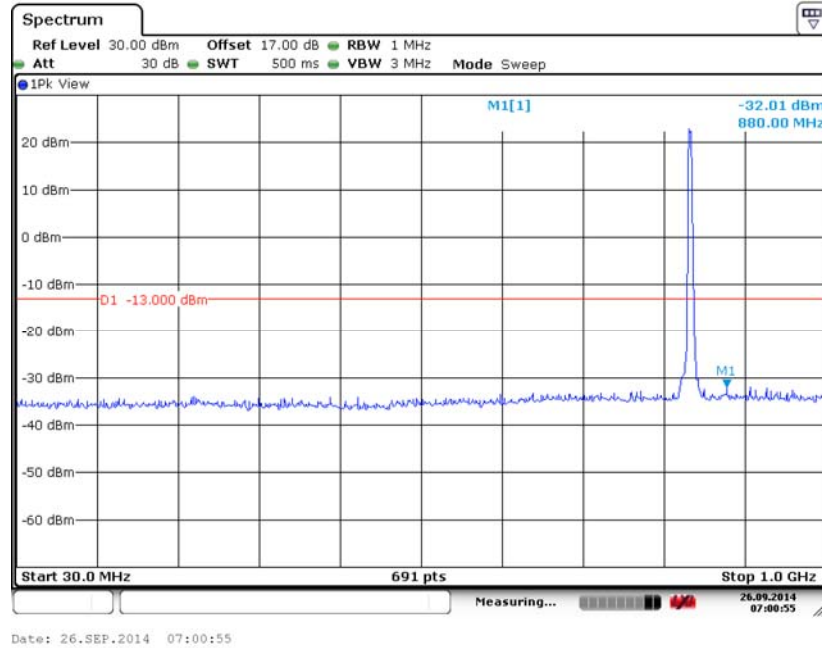

Conducted Spurious Emission Plot between 1GHz ~ 3GHz

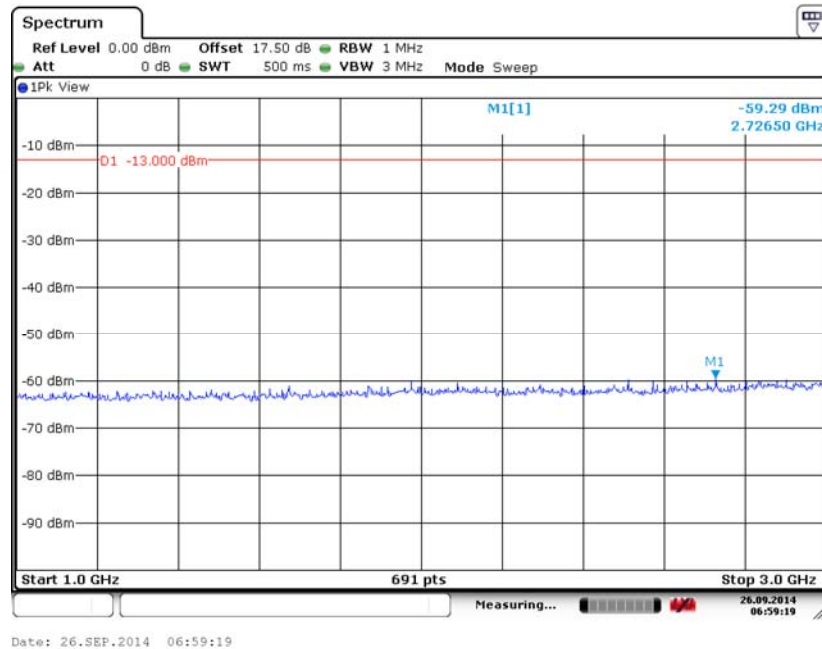



Conducted Spurious Emission Plot between 3GHz ~ 7GHz

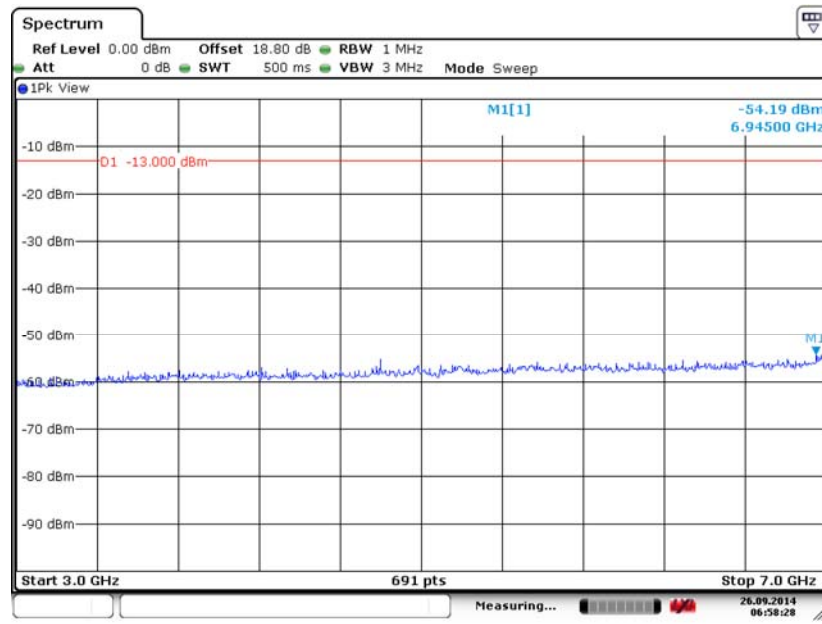

Date: 26.SEP.2014 06:58:28

Conducted Spurious Emission Plot between 7GHz ~ 9GHz

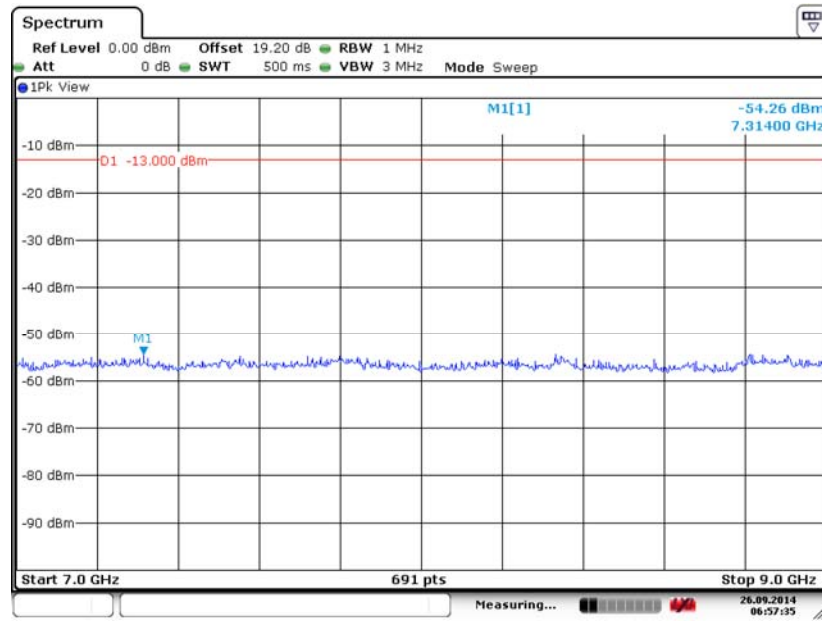

Date: 26.SEP.2014 06:57:36



Band :	WCDMA Band II	Channel :	CH9400
Test Mode :	RMC 12.2Kbps Link (QPSK)	Frequency :	1880.0 MHz

Conducted Spurious Emission Plot between 30MHz ~ 1GHz

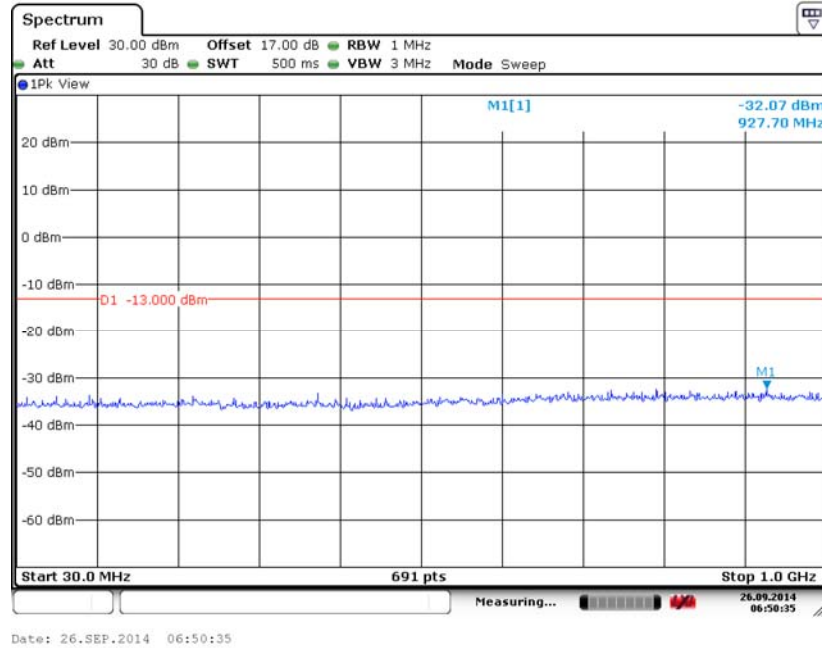

Conducted Spurious Emission Plot between 1GHz ~ 3GHz

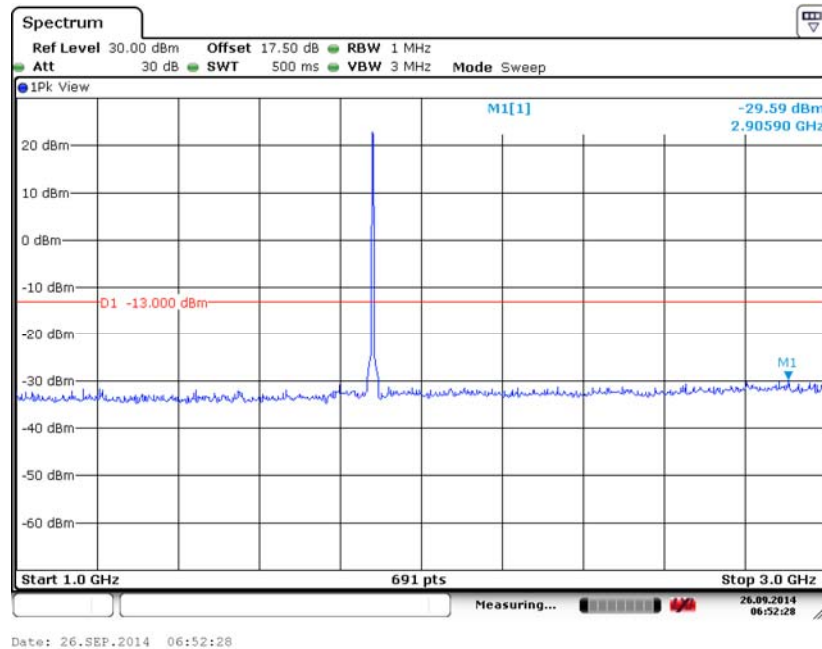



Conducted Spurious Emission Plot between 3GHz ~ 7GHz

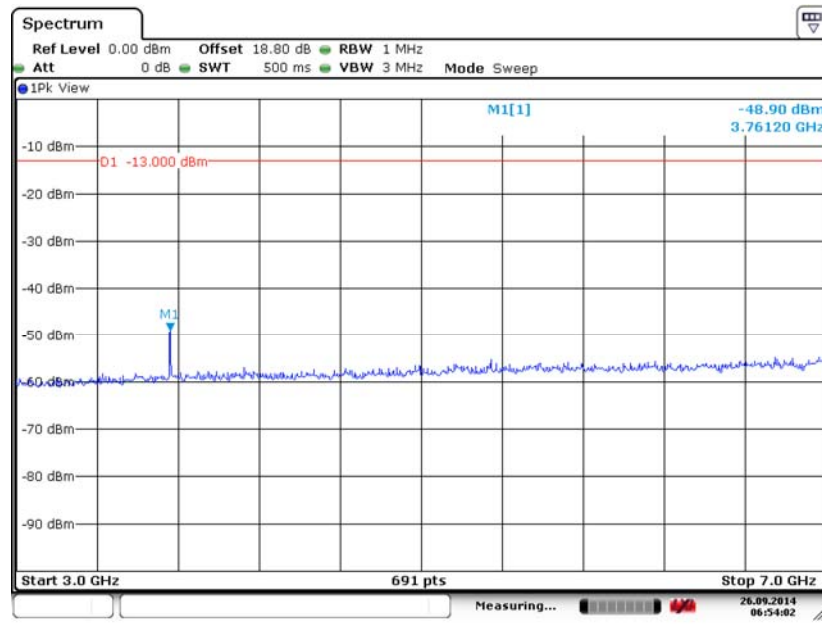

Date: 26.SEP.2014 06:54:02

Conducted Spurious Emission Plot between 7GHz ~ 13.6GHz

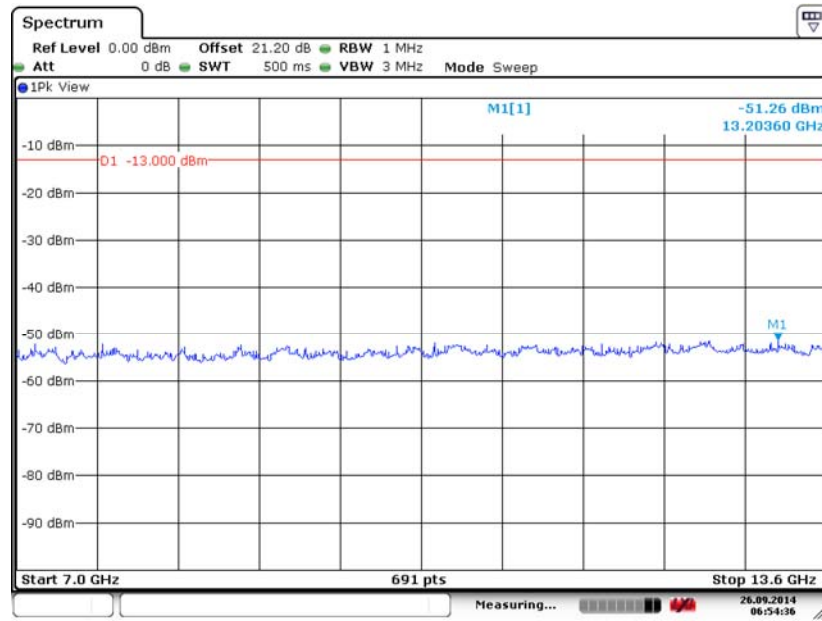

Date: 26.SEP.2014 06:54:36



Conducted Spurious Emission Plot between 13.6GHz ~ 19.1GHz

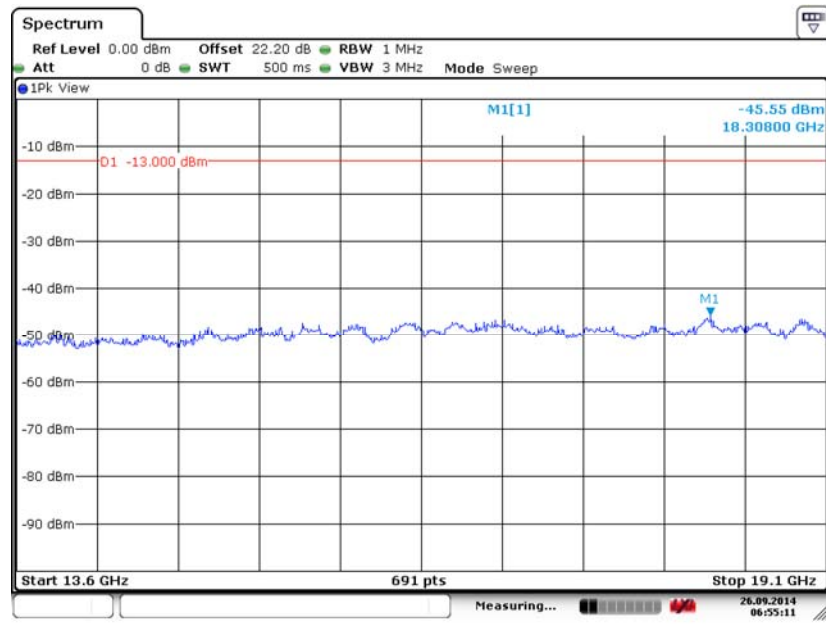

Date: 26.SEP.2014 06:55:11



3.7 Field Strength of Spurious Radiation Measurement

3.7.1 Description of Field Strength of Spurious Radiated Measurement

The power of any emission outside of the authorized operating frequency ranges must be attenuated below the transmitter power (P) by a factor of at least $43 + 10 \log (P)$ dB. The spectrum is scanned from 30 MHz up to a frequency including its 10th harmonic.

3.7.2 Measuring Instruments

The measuring equipment is listed in the section 4 of this test report.

3.7.3 Test Procedures

1. The testing follows FCC KDB 971168 v02r01 Section 5.8 and ANSI / TIA-603-C-2004 Section 2.2.12.
2. The EUT was placed on a rotatable wooden table 0.8 meters above the ground.
3. The EUT was set 3 meters from the receiving antenna, which was mounted on the antenna tower.
4. The table was rotated 360 degrees to determine the position of the highest spurious emission.
5. The height of the receiving antenna is varied between one meter and four meters to search for the maximum spurious emission for both horizontal and vertical polarizations.
6. Make the measurement with the spectrum analyzer's RBW = 1MHz, VBW = 3MHz, taking record of maximum spurious emission.
7. A horn antenna was substituted in place of the EUT and was driven by a signal generator.
8. Tune the output power of signal generator to the same emission level with EUT maximum spurious emission.
9. Taking the record of output power at antenna port.
10. Repeat step 7 to step 8 for another polarization.
11. $EIRP \text{ (dBm)} = S.G. \text{ Power} - Tx \text{ Cable Loss} + Tx \text{ Antenna Gain}$
12. $ERP \text{ (dBm)} = EIRP - 2.15$
13. The RF fundamental frequency should be excluded against the limit line in the operating frequency band.
14. The limit line is derived from $43 + 10\log(P)$ dB below the transmitter power P(Watts)
= $P(W) - [43 + 10\log(P)] \text{ (dB)}$
= $[30 + 10\log(P)] \text{ (dBm)} - [43 + 10\log(P)] \text{ (dB)}$
= -13dBm.

3.7.4 Test Setup

For radiated emissions from 30MHz to 1GHz

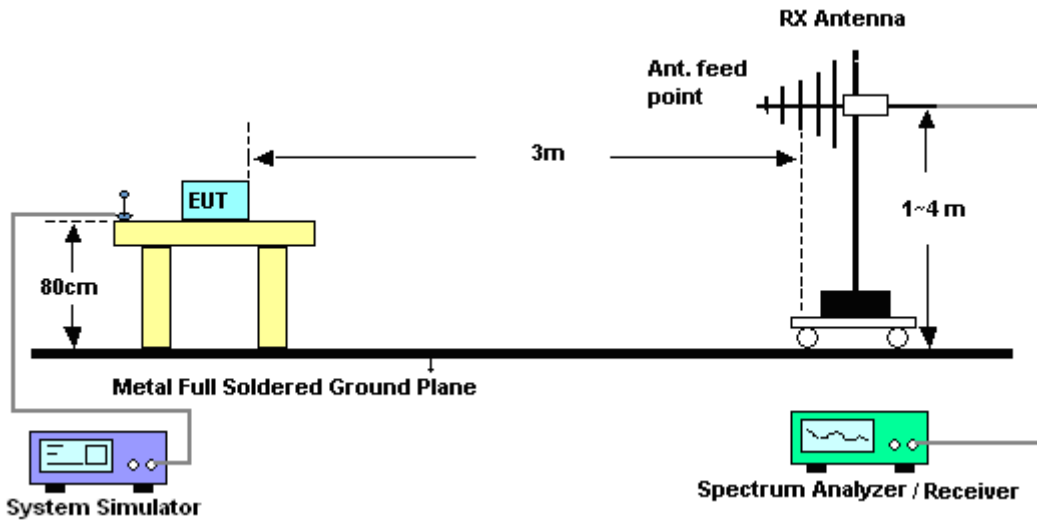

For radiated emissions above 1GHz

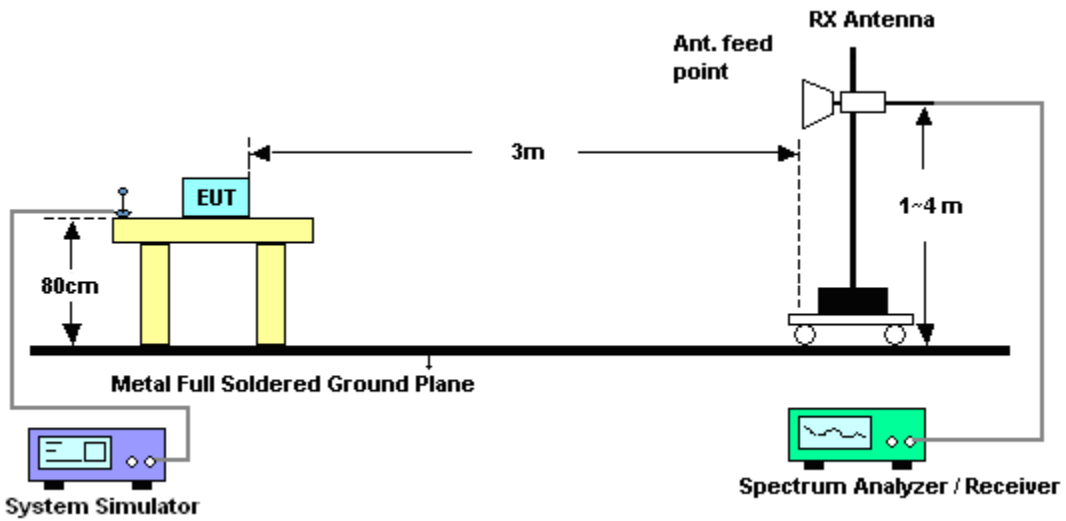



3.7.5 Test Result of Field Strength of Spurious Radiated

Band :	GSM850 for CH128		Temperature :	23~25°C					
Test Mode :	GSM Link (GMSK)		Relative Humidity :	48~52%					
Test Engineer :	Kear Huang		Polarization :	Horizontal					
Remark :	Spurious emissions within 30-1000MHz were found more than 20dB below limit line.								
Frequency (MHz)	ERP (dBm)	Limit (dBm)	Over Limit (dB)	SPA Reading (dBm)	S.G. Power (dBm)	TX Cable loss (dB)	TX Antenna Gain (dBi)	Polarization (H/V)	Result
1648.4	-19.13	-13	-6.13	-36.31	-21.95	0.73	5.70	H	Pass
2472.6	-19.08	-13	-6.08	-45.05	-21.44	0.91	5.42	H	Pass
3296.8	-49.14	-13	-36.14	-60.01	-53.78	1.07	7.86	H	Pass

Band :	GSM850 for CH128		Temperature :	23~25°C					
Test Mode :	GSM Link (GMSK)		Relative Humidity :	48~52%					
Test Engineer :	Kear Huang		Polarization :	Vertical					
Remark :	Spurious emissions within 30-1000MHz were found more than 20dB below limit line.								
Frequency (MHz)	ERP (dBm)	Limit (dBm)	Over Limit (dB)	SPA Reading (dBm)	S.G. Power (dBm)	TX Cable loss (dB)	TX Antenna Gain (dBi)	Polarization (H/V)	Result
1648.4	-25.32	-13	-12.32	-40.14	-28.14	0.73	5.70	V	Pass
2472.6	-23.35	-13	-10.35	-46.83	-25.71	0.91	5.42	V	Pass
3296.8	-48.69	-13	-35.69	-61.37	-53.33	1.07	7.86	V	Pass



Band :	GSM850 for CH189				Temperature :	23~25°C			
Test Mode :	GSM Link (GMSK)				Relative Humidity :	48~52%			
Test Engineer :	Rock Tang				Polarization :	Horizontal			
Remark :	Spurious emissions within 30-1000MHz were found more than 20dB below limit line.								
Frequency (MHz)	ERP (dBm)	Limit (dBm)	Over Limit (dB)	SPA Reading (dBm)	S.G. Power (dBm)	TX Cable loss (dB)	TX Antenna Gain (dBi)	Polarization (H/V)	Result
1672	-37.42	-13	-24.42	-54.23	-40.39	0.88	6.00	H	Pass
2510	-27.49	-13	-14.49	-52.97	-30.10	1.08	5.84	H	Pass
3346	-61.07	-13	-48.07	-71.67	-65.44	1.14	7.66	H	Pass

Band :	GSM850 for CH189				Temperature :	23~25°C			
Test Mode :	GSM Link (GMSK)				Relative Humidity :	48~52%			
Test Engineer :	Kear Huang				Polarization :	Vertical			
Remark :	Spurious emissions within 30-1000MHz were found more than 20dB below limit line.								
Frequency (MHz)	ERP (dBm)	Limit (dBm)	Over Limit (dB)	SPA Reading (dBm)	S.G. Power (dBm)	TX Cable loss (dB)	TX Antenna Gain (dBi)	Polarization (H/V)	Result
1672	-42.73	-13	-29.73	-56.12	-45.70	0.88	6.00	V	Pass
2510	-30.34	-13	-17.34	-53.36	-32.95	1.08	5.84	V	Pass
3346	-57.32	-13	-44.32	-69.15	-61.69	1.14	7.66	V	Pass



Band :	GSM850 for CH251				Temperature :	23~25°C			
Test Mode :	GSM Link (GMSK)				Relative Humidity :	48~52%			
Test Engineer :	Rock Tang				Polarization :	Horizontal			
Remark :	Spurious emissions within 30-1000MHz were found more than 20dB below limit line.								
Frequency (MHz)	ERP (dBm)	Limit (dBm)	Over Limit (dB)	SPA Reading (dBm)	S.G. Power (dBm)	TX Cable loss (dB)	TX Antenna Gain (dBi)	Polarization (H/V)	Result
1697.6	-41.48	-13	-28.48	-58.30	-44.47	0.75	5.89	H	Pass
2546.4	-42.11	-13	-29.11	-66.36	-44.82	1.12	5.98	H	Pass
3395.2	-60.38	-13	-47.38	-71.58	-64.78	1.25	7.80	H	Pass

Band :	GSM850 for CH251				Temperature :	23~25°C			
Test Mode :	GSM Link (GMSK)				Relative Humidity :	48~52%			
Test Engineer :	Kear Huang				Polarization :	Vertical			
Remark :	Spurious emissions within 30-1000MHz were found more than 20dB below limit line.								
Frequency (MHz)	ERP (dBm)	Limit (dBm)	Over Limit (dB)	SPA Reading (dBm)	S.G. Power (dBm)	TX Cable loss (dB)	TX Antenna Gain (dBi)	Polarization (H/V)	Result
1697.6	-50.15	-13	-37.15	-62.88	-53.14	0.75	5.89	V	Pass
2546.4	-45.76	-13	-32.76	-67.52	-48.47	1.12	5.98	V	Pass
3395.2	-58.55	-13	-45.55	-70.98	-62.95	1.25	7.80	V	Pass



Band :	GSM850 for CH128	Temperature :	23~25°C						
Test Mode :	EDGE class 8 Link (8PSK)	Relative Humidity :	48~52%						
Test Engineer :	Kear Huang	Polarization :	Horizontal						
Remark :	Spurious emissions within 30-1000MHz were found more than 20dB below limit line.								
Frequency (MHz)	ERP (dBm)	Limit (dBm)	Over Limit (dB)	SPA Reading (dBm)	S.G. Power (dBm)	TX Cable loss (dB)	TX Antenna Gain (dBi)	Polarization (H/V)	Result
1648.4	-34.77	-13	-21.77	-52.13	-37.59	0.73	5.70	H	Pass
2472.6	-23.81	-13	-10.81	-49.70	-26.17	0.91	5.42	H	Pass
3296.8	-60.00	-13	-47.00	-70.87	-64.64	1.07	7.86	H	Pass

Band :	GSM850 for CH128	Temperature :	23~25°C						
Test Mode :	EDGE class 8 Link (8PSK)	Relative Humidity :	48~52%						
Test Engineer :	Kear Huang	Polarization :	Vertical						
Remark :	Spurious emissions within 30-1000MHz were found more than 20dB below limit line.								
Frequency (MHz)	ERP (dBm)	Limit (dBm)	Over Limit (dB)	SPA Reading (dBm)	S.G. Power (dBm)	TX Cable loss (dB)	TX Antenna Gain (dBi)	Polarization (H/V)	Result
1648.4	-44.53	-13	-31.53	-58.49	-47.35	0.73	5.70	V	Pass
2472.6	-29.79	-13	-16.79	-53.12	-32.15	0.91	5.42	V	Pass
3296.8	-59.27	-13	-46.27	-71.45	-63.91	1.07	7.86	V	Pass



Band :	GSM850 for CH189		Temperature :	23~25°C					
Test Mode :	EDGE class 8 Link (8PSK)		Relative Humidity :	48~52%					
Test Engineer :	Kear Huang		Polarization :	Horizontal					
Remark :	Spurious emissions within 30-1000MHz were found more than 20dB below limit line.								
Frequency (MHz)	ERP (dBm)	Limit (dBm)	Over Limit (dB)	SPA Reading (dBm)	S.G. Power (dBm)	TX Cable loss (dB)	TX Antenna Gain (dBi)	Polarization (H/V)	Result
1672	-41.46	-13	-28.46	-57.94	-44.43	0.88	6.00	H	Pass
2510	-41.48	-13	-28.48	-65.49	-44.09	1.08	5.84	H	Pass
3346	-61.45	-13	-48.45	-72.05	-65.82	1.14	7.66	H	Pass

Band :	GSM850 for CH189		Temperature :	23~25°C					
Test Mode :	EDGE class 8 Link (8PSK)		Relative Humidity :	48~52%					
Test Engineer :	Kear Huang		Polarization :	Vertical					
Remark :	Spurious emissions within 30-1000MHz were found more than 20dB below limit line.								
Frequency (MHz)	ERP (dBm)	Limit (dBm)	Over Limit (dB)	SPA Reading (dBm)	S.G. Power (dBm)	TX Cable loss (dB)	TX Antenna Gain (dBi)	Polarization (H/V)	Result
1672	-48.98	-13	-35.98	-61.89	-51.95	0.88	6.00	V	Pass
2510	-47.22	-13	-34.22	-68.02	-49.83	1.08	5.84	V	Pass
3346	-59.18	-13	-46.18	-71.01	-63.55	1.14	7.66	V	Pass



Band :	GSM850 for CH251		Temperature :	23~25°C					
Test Mode :	EDGE class 8 Link (8PSK)		Relative Humidity :	48~52%					
Test Engineer :	Kear Huang		Polarization :	Horizontal					
Remark :	Spurious emissions within 30-1000MHz were found more than 20dB below limit line.								
Frequency (MHz)	ERP (dBm)	Limit (dBm)	Over Limit (dB)	SPA Reading (dBm)	S.G. Power (dBm)	TX Cable loss (dB)	TX Antenna Gain (dBi)	Polarization (H/V)	Result
1697.6	-48.63	-13	-35.63	-63.90	-51.62	0.75	5.89	H	Pass
2546.4	-46.88	-13	-33.88	-69.88	-49.59	1.12	5.98	H	Pass
3395.2	-59.76	-13	-46.76	-70.96	-64.16	1.25	7.80	H	Pass

Band :	GSM850 for CH251		Temperature :	23~25°C					
Test Mode :	EDGE class 8 Link (8PSK)		Relative Humidity :	48~52%					
Test Engineer :	Kear Huang		Polarization :	Vertical					
Remark :	Spurious emissions within 30-1000MHz were found more than 20dB below limit line.								
Frequency (MHz)	ERP (dBm)	Limit (dBm)	Over Limit (dB)	SPA Reading (dBm)	S.G. Power (dBm)	TX Cable loss (dB)	TX Antenna Gain (dBi)	Polarization (H/V)	Result
1697.6	-55.57	-13	-42.57	-66.55	-58.56	0.75	5.89	V	Pass
2546.4	-49.55	-13	-36.55	-70.01	-52.26	1.12	5.98	V	Pass
3395.2	-59.52	-13	-46.52	-71.95	-63.92	1.25	7.80	V	Pass



Band :	GSM1900 for CH512	Temperature :	23~25°C						
Test Mode :	GSM Link (GMSK)	Relative Humidity :	48~52%						
Test Engineer :	Kear Huang	Polarization :	Horizontal						
Remark :	Spurious emissions within 30-1000MHz were found more than 20dB below limit line.								
Frequency (MHz)	EIRP (dBm)	Limit (dBm)	Over Limit (dB)	SPA Reading (dBm)	S.G. Power (dBm)	TX Cable loss (dB)	TX Antenna Gain (dBi)	Polarization (H/V)	Result
3700.4	-39.45	-13	-26.45	-55.28	-46.20	1.2	7.95	H	Pass
5550.6	-41.73	-13	-28.73	-60.43	-49.83	1.5	9.60	H	Pass
7400.8	-49.27	-13	-36.27	-70.85	-59.46	1.7	11.89	H	Pass

Band :	GSM1900 for CH512	Temperature :	23~25°C						
Test Mode :	GSM Link (GMSK)	Relative Humidity :	48~52%						
Test Engineer :	Kear Huang	Polarization :	Vertical						
Remark :	Spurious emissions within 30-1000MHz were found more than 20dB below limit line.								
Frequency (MHz)	EIRP (dBm)	Limit (dBm)	Over Limit (dB)	SPA Reading (dBm)	S.G. Power (dBm)	TX Cable loss (dB)	TX Antenna Gain (dBi)	Polarization (H/V)	Result
3700.4	-42.50	-13	-29.50	-58.43	-49.25	1.2	7.95	V	Pass
5550.6	-42.58	-13	-29.58	-60.5	-50.68	1.5	9.6	V	Pass
7400.8	-48.09	-13	-35.09	-69.98	-58.28	1.7	11.89	V	Pass



Band :	GSM1900 for CH661	Temperature :	23~25°C						
Test Mode :	GSM Link (GMSK)	Relative Humidity :	48~52%						
Test Engineer :	Kear Huang	Polarization :	Horizontal						
Remark :	Spurious emissions within 30-1000MHz were found more than 20dB below limit line.								
Frequency (MHz)	EIRP (dBm)	Limit (dBm)	Over Limit (dB)	SPA Reading (dBm)	S.G. Power (dBm)	TX Cable loss (dB)	TX Antenna Gain (dBi)	Polarization (H/V)	Result
3760	-49.48	-13	-36.48	-62.93	-56.22	1.28	8.02	H	Pass
5640	-44.83	-13	-31.83	-63.40	-53.25	1.58	10.00	H	Pass
7520	-52.21	-13	-39.21	-74.15	-62.53	1.78	12.10	H	Pass

Band :	GSM1900 for CH661	Temperature :	23~25°C						
Test Mode :	GSM Link (GMSK)	Relative Humidity :	48~52%						
Test Engineer :	Kear Huang	Polarization :	Vertical						
Remark :	Spurious emissions within 30-1000MHz were found more than 20dB below limit line.								
Frequency (MHz)	EIRP (dBm)	Limit (dBm)	Over Limit (dB)	SPA Reading (dBm)	S.G. Power (dBm)	TX Cable loss (dB)	TX Antenna Gain (dBi)	Polarization (H/V)	Result
3760	-49.04	-13	-36.04	-64.07	-55.78	1.28	8.02	V	Pass
5640	-46.92	-13	-33.92	-64.04	-55.34	1.58	10	V	Pass
7520	-53.56	-13	-40.56	-75.81	-63.88	1.78	12.1	V	Pass



Band :	GSM1900 for CH810	Temperature :	23~25°C						
Test Mode :	GSM Link (GMSK)	Relative Humidity :	48~52%						
Test Engineer :	Kear Huang	Polarization :	Horizontal						
Remark :	Spurious emissions within 30-1000MHz were found more than 20dB below limit line.								
Frequency (MHz)	EIRP (dBm)	Limit (dBm)	Over Limit (dB)	SPA Reading (dBm)	S.G. Power (dBm)	TX Cable loss (dB)	TX Antenna Gain (dBi)	Polarization (H/V)	Result
3819.6	-45.15	-13	-32.15	-59.49	-51.92	1.23	8.00	H	Pass
5729.4	-43.63	-13	-30.63	-62.39	-51.76	1.52	9.65	H	Pass
7639.2	-52.74	-13	-39.74	-74.98	-62.92	1.82	12.00	H	Pass

Band :	GSM1900 for CH810	Temperature :	23~25°C						
Test Mode :	GSM Link (GMSK)	Relative Humidity :	48~52%						
Test Engineer :	Kear Huang	Polarization :	Vertical						
Remark :	Spurious emissions within 30-1000MHz were found more than 20dB below limit line.								
Frequency (MHz)	EIRP (dBm)	Limit (dBm)	Over Limit (dB)	SPA Reading (dBm)	S.G. Power (dBm)	TX Cable loss (dB)	TX Antenna Gain (dBi)	Polarization (H/V)	Result
3819.6	-45.35	-13	-32.35	-60.81	-52.12	1.23	8	V	Pass
5729.4	-48.70	-13	-35.70	-65.59	-56.83	1.52	9.65	V	Pass
7639.2	-52.11	-13	-39.11	-74.66	-62.29	1.82	12	V	Pass



Band :	GSM1900 for CH512	Temperature :	23~25°C						
Test Mode :	EDGE class 8 Link (8PSK)	Relative Humidity :	48~52%						
Test Engineer :	Kear Huang	Polarization :	Horizontal						
Remark :	Spurious emissions within 30-1000MHz were found more than 20dB below limit line.								
Frequency (MHz)	EIRP (dBm)	Limit (dBm)	Over Limit (dB)	SPA Reading (dBm)	S.G. Power (dBm)	TX Cable loss (dB)	TX Antenna Gain (dBi)	Polarization (H/V)	Result
3700.4	-39.33	-13	-26.33	-55.21	-46.08	1.2	7.95	H	Pass
5550.6	-45.80	-13	-32.80	-63.29	-53.90	1.5	9.60	H	Pass
7400.8	-48.35	-13	-35.35	-69.93	-58.54	1.7	11.89	H	Pass

Band :	GSM1900 for CH512	Temperature :	23~25°C						
Test Mode :	EDGE class 8 Link (8PSK)	Relative Humidity :	48~52%						
Test Engineer :	Kear Huang	Polarization :	Vertical						
Remark :	Spurious emissions within 30-1000MHz were found more than 20dB below limit line.								
Frequency (MHz)	EIRP (dBm)	Limit (dBm)	Over Limit (dB)	SPA Reading (dBm)	S.G. Power (dBm)	TX Cable loss (dB)	TX Antenna Gain (dBi)	Polarization (H/V)	Result
3700.4	-44.18	-13	-31.18	-59.63	-50.93	1.2	7.95	V	Pass
5550.6	-44.91	-13	-31.91	-61.98	-53.01	1.5	9.6	V	Pass
7400.8	-46.32	-13	-33.32	-68.21	-56.51	1.7	11.89	V	Pass



Band :	GSM1900 for CH661		Temperature :	23~25°C					
Test Mode :	EDGE class 8 Link (8PSK)		Relative Humidity :	48~52%					
Test Engineer :	Kear Huang		Polarization :	Horizontal					
Remark :	Spurious emissions within 30-1000MHz were found more than 20dB below limit line.								
Frequency (MHz)	EIRP (dBm)	Limit (dBm)	Over Limit (dB)	SPA Reading (dBm)	S.G. Power (dBm)	TX Cable loss (dB)	TX Antenna Gain (dBi)	Polarization (H/V)	Result
3760	-53.32	-13	-40.32	-65.47	-60.06	1.28	8.02	H	Pass
5640	-47.75	-13	-34.75	-65.74	-56.17	1.58	10.00	H	Pass
7520	-54.15	-13	-41.15	-76.09	-64.47	1.78	12.10	H	Pass

Band :	GSM1900 for CH661		Temperature :	23~25°C					
Test Mode :	EDGE class 8 Link (8PSK)		Relative Humidity :	48~52%					
Test Engineer :	Kear Huang		Polarization :	Vertical					
Remark :	Spurious emissions within 30-1000MHz were found more than 20dB below limit line.								
Frequency (MHz)	EIRP (dBm)	Limit (dBm)	Over Limit (dB)	SPA Reading (dBm)	S.G. Power (dBm)	TX Cable loss (dB)	TX Antenna Gain (dBi)	Polarization (H/V)	Result
3760	-52.81	-13	-39.81	-67.84	-59.55	1.28	8.02	V	Pass
5640	-47.37	-13	-34.37	-64.45	-55.79	1.58	10	V	Pass
7520	-53.42	-13	-40.42	-75.67	-63.74	1.78	12.1	V	Pass



Band :	GSM1900 for CH810		Temperature :	23~25°C					
Test Mode :	EDGE class 8 Link (8PSK)		Relative Humidity :	48~52%					
Test Engineer :	Kear Huang		Polarization :	Horizontal					
Remark :	Spurious emissions within 30-1000MHz were found more than 20dB below limit line.								
Frequency (MHz)	EIRP (dBm)	Limit (dBm)	Over Limit (dB)	SPA Reading (dBm)	S.G. Power (dBm)	TX Cable loss (dB)	TX Antenna Gain (dBi)	Polarization (H/V)	Result
3819.6	-46.42	-13	-33.42	-60.46	-53.19	1.23	8.00	H	Pass
5729.4	-44.62	-13	-31.62	-63.09	-52.75	1.52	9.65	H	Pass
7639.2	-53.00	-13	-40.00	-75.24	-63.18	1.82	12.00	H	Pass

Band :	GSM1900 for CH810		Temperature :	23~25°C					
Test Mode :	EDGE class 8 Link (8PSK)		Relative Humidity :	48~52%					
Test Engineer :	Kear Huang		Polarization :	Vertical					
Remark :	Spurious emissions within 30-1000MHz were found more than 20dB below limit line.								
Frequency (MHz)	EIRP (dBm)	Limit (dBm)	Over Limit (dB)	SPA Reading (dBm)	S.G. Power (dBm)	TX Cable loss (dB)	TX Antenna Gain (dBi)	Polarization (H/V)	Result
3819.6	-50.48	-13	-37.48	-64.93	-57.25	1.23	8	V	Pass
5729.4	-48.33	-13	-35.33	-65.22	-56.46	1.52	9.65	V	Pass
7639.2	-52.69	-13	-39.69	-75.24	-62.87	1.82	12	V	Pass



Band :	WCDMA Band V for CH4132	Temperature :	23~25°C						
Test Mode :	RMC 12.2Kbps Link (QPSK)	Relative Humidity :	48~52%						
Test Engineer :	Kear Huang	Polarization :	Horizontal						
Remark :	Spurious emissions within 30-1000MHz were found more than 20dB below limit line.								
Frequency (MHz)	ERP (dBm)	Limit (dBm)	Over Limit (dB)	SPA Reading (dBm)	S.G. Power (dBm)	TX Cable loss (dB)	TX Antenna Gain (dBi)	Polarization (H/V)	Result
1652.8	-48.53	-13	-35.53	-64.28	-51.52	0.81	5.95	H	Pass
2479.2	-46.75	-13	-33.75	-68.94	-49.20	1.2	5.80	H	Pass
3305.6	-61.17	-13	-48.17	-71.77	-65.47	1.25	7.70	H	Pass

Band :	WCDMA Band V for CH4132	Temperature :	23~25°C						
Test Mode :	RMC 12.2Kbps Link (QPSK)	Relative Humidity :	48~52%						
Test Engineer :	Kear Huang	Polarization :	Vertical						
Remark :	Spurious emissions within 30-1000MHz were found more than 20dB below limit line.								
Frequency (MHz)	ERP (dBm)	Limit (dBm)	Over Limit (dB)	SPA Reading (dBm)	S.G. Power (dBm)	TX Cable loss (dB)	TX Antenna Gain (dBi)	Polarization (H/V)	Result
1652.8	-53.74	-13	-40.74	-65.98	-56.73	0.81	5.95	V	Pass
2479.2	-49.74	-13	-36.74	-69.29	-52.19	1.20	5.80	V	Pass
3305.6	-60.11	-13	-47.11	-71.94	-64.41	1.25	7.70	V	Pass



Band :	WCDMA Band V for CH4182	Temperature :	23~25°C						
Test Mode :	RMC 12.2Kbps Link (QPSK)	Relative Humidity :	48~52%						
Test Engineer :	Kear Huang	Polarization :	Horizontal						
Remark :	Spurious emissions within 30-1000MHz were found more than 20dB below limit line.								
Frequency (MHz)	ERP (dBm)	Limit (dBm)	Over Limit (dB)	SPA Reading (dBm)	S.G. Power (dBm)	TX Cable loss (dB)	TX Antenna Gain (dBi)	Polarization (H/V)	Result
1672	-49.93	-13	-36.93	-64.63	-52.90	0.88	6.00	H	Pass
2510	-47.21	-13	-34.21	-69.69	-49.82	1.08	5.84	H	Pass
3346	-60.75	-13	-47.75	-71.35	-65.12	1.14	7.66	H	Pass

Band :	WCDMA Band V for CH4182	Temperature :	23~25°C						
Test Mode :	RMC 12.2Kbps Link (QPSK)	Relative Humidity :	48~52%						
Test Engineer :	Kear Huang	Polarization :	Vertical						
Remark :	Spurious emissions within 30-1000MHz were found more than 20dB below limit line.								
Frequency (MHz)	ERP (dBm)	Limit (dBm)	Over Limit (dB)	SPA Reading (dBm)	S.G. Power (dBm)	TX Cable loss (dB)	TX Antenna Gain (dBi)	Polarization (H/V)	Result
1672	-57.75	-13	-44.75	-68.38	-60.72	0.88	6.00	V	Pass
2510	-50.00	-13	-37.00	-69.90	-52.61	1.08	5.84	V	Pass
3346	-59.78	-13	-46.78	-71.61	-64.15	1.14	7.66	V	Pass



Band :	WCDMA Band V for CH4233	Temperature :	23~25°C						
Test Mode :	RMC 12.2Kbps Link (QPSK)	Relative Humidity :	48~52%						
Test Engineer :	Kear Huang	Polarization :	Horizontal						
Remark :	Spurious emissions within 30-1000MHz were found more than 20dB below limit line.								
Frequency (MHz)	ERP (dBm)	Limit (dBm)	Over Limit (dB)	SPA Reading (dBm)	S.G. Power (dBm)	TX Cable loss (dB)	TX Antenna Gain (dBi)	Polarization (H/V)	Result
1693.2	-54.04	-13	-41.04	-67.58	-57.37	0.82	6.30	H	Pass
2539.8	-48.50	-13	-35.50	-70.26	-51.11	1.08	5.84	H	Pass
3386.4	-60.60	-13	-47.60	-71.49	-64.72	1.23	7.50	H	Pass

Band :	WCDMA Band V for CH4233	Temperature :	23~25°C						
Test Mode :	RMC 12.2Kbps Link (QPSK)	Relative Humidity :	48~52%						
Test Engineer :	Kear Huang	Polarization :	Vertical						
Remark :	Spurious emissions within 30-1000MHz were found more than 20dB below limit line.								
Frequency (MHz)	ERP (dBm)	Limit (dBm)	Over Limit (dB)	SPA Reading (dBm)	S.G. Power (dBm)	TX Cable loss (dB)	TX Antenna Gain (dBi)	Polarization (H/V)	Result
1693.2	-58.09	-13	-45.09	-69.34	-61.42	0.82	6.30	V	Pass
2539.8	-50.80	-13	-37.80	-70.34	-53.41	1.08	5.84	V	Pass
3386.4	-59.64	-13	-46.64	-71.76	-63.76	1.23	7.50	V	Pass



Band :	WCDMA Band II for CH9262	Temperature :	23~25°C						
Test Mode :	RMC 12.2Kbps Link (QPSK)	Relative Humidity :	48~52%						
Test Engineer :	Kear Huang	Polarization :	Horizontal						
Remark :	Spurious emissions within 30-1000MHz were found more than 20dB below limit line.								
Frequency (MHz)	EIRP (dBm)	Limit (dBm)	Over Limit (dB)	SPA Reading (dBm)	S.G. Power (dBm)	TX Cable loss (dB)	TX Antenna Gain (dBi)	Polarization (H/V)	Result
3704.8	-60.23	-13	-47.23	-72.09	-67.08	1.35	8.20	H	Pass
5557.2	-55.85	-13	-42.85	-73.58	-64.46	1.65	10.26	H	Pass
7409.6	-52.36	-13	-39.36	-74.80	-62.70	1.82	12.16	H	Pass

Band :	WCDMA Band II for CH9262	Temperature :	23~25°C						
Test Mode :	RMC 12.2Kbps Link (QPSK)	Relative Humidity :	48~52%						
Test Engineer :	Kear Huang	Polarization :	Vertical						
Remark :	Spurious emissions within 30-1000MHz were found more than 20dB below limit line.								
Frequency (MHz)	EIRP (dBm)	Limit (dBm)	Over Limit (dB)	SPA Reading (dBm)	S.G. Power (dBm)	TX Cable loss (dB)	TX Antenna Gain (dBi)	Polarization (H/V)	Result
3704.8	-58.37	-13	-45.37	-73.11	-65.22	1.35	8.2	V	Pass
5557.2	-56.53	-13	-43.53	-73.35	-65.14	1.65	10.26	V	Pass
7409.6	-52.86	-13	-39.86	-75.61	-63.20	1.82	12.16	V	Pass



Band :	WCDMA Band II for CH9400	Temperature :	23~25°C						
Test Mode :	RMC 12.2Kbps Link (QPSK)	Relative Humidity :	48~52%						
Test Engineer :	Kear Huang	Polarization :	Horizontal						
Remark :	Spurious emissions within 30-1000MHz were found more than 20dB below limit line.								
Frequency (MHz)	EIRP (dBm)	Limit (dBm)	Over Limit (dB)	SPA Reading (dBm)	S.G. Power (dBm)	TX Cable loss (dB)	TX Antenna Gain (dBi)	Polarization (H/V)	Result
3760	-60.47	-13	-47.47	-72.62	-67.21	1.28	8.02	H	Pass
5640	-54.44	-13	-41.44	-72.43	-62.86	1.58	10.00	H	Pass
7520	-52.70	-13	-39.70	-74.64	-63.02	1.78	12.10	H	Pass

Band :	WCDMA Band II for CH9400	Temperature :	23~25°C						
Test Mode :	RMC 12.2Kbps Link (QPSK)	Relative Humidity :	48~52%						
Test Engineer :	Kear Huang	Polarization :	Vertical						
Remark :	Spurious emissions within 30-1000MHz were found more than 20dB below limit line.								
Frequency (MHz)	EIRP (dBm)	Limit (dBm)	Over Limit (dB)	SPA Reading (dBm)	S.G. Power (dBm)	TX Cable loss (dB)	TX Antenna Gain (dBi)	Polarization (H/V)	Result
3760	-57.95	-13	-44.95	-72.98	-64.69	1.28	8.02	V	Pass
5640	-56.00	-13	-43.00	-73.08	-64.42	1.58	10	V	Pass
7520	-53.44	-13	-40.44	-75.69	-63.76	1.78	12.1	V	Pass



Band :	WCDMA Band II for CH9538	Temperature :	23~25°C						
Test Mode :	RMC 12.2Kbps Link (QPSK)	Relative Humidity :	48~52%						
Test Engineer :	Kear Huang	Polarization :	Horizontal						
Remark :	Spurious emissions within 30-1000MHz were found more than 20dB below limit line.								
Frequency (MHz)	EIRP (dBm)	Limit (dBm)	Over Limit (dB)	SPA Reading (dBm)	S.G. Power (dBm)	TX Cable loss (dB)	TX Antenna Gain (dBi)	Polarization (H/V)	Result
3815.2	-59.10	-13	-46.10	-71.25	-65.84	1.28	8.02	H	Pass
5722.8	-54.99	-13	-41.99	-72.98	-63.41	1.58	10.00	H	Pass
7630.4	-53.57	-13	-40.57	-75.51	-63.89	1.78	12.10	H	Pass

Band :	WCDMA Band II for CH9538	Temperature :	23~25°C						
Test Mode :	RMC 12.2Kbps Link (QPSK)	Relative Humidity :	48~52%						
Test Engineer :	Kear Huang	Polarization :	Vertical						
Remark :	Spurious emissions within 30-1000MHz were found more than 20dB below limit line.								
Frequency (MHz)	EIRP (dBm)	Limit (dBm)	Over Limit (dB)	SPA Reading (dBm)	S.G. Power (dBm)	TX Cable loss (dB)	TX Antenna Gain (dBi)	Polarization (H/V)	Result
3815.2	-58.15	-13	-45.15	-73.18	-64.89	1.28	8.02	V	Pass
5722.8	-56.32	-13	-43.32	-73.4	-64.74	1.58	10	V	Pass
7630.4	-53.36	-13	-40.36	-75.61	-63.68	1.78	12.1	V	Pass

3.8 Frequency Stability Measurement

3.8.1 Description of Frequency Stability Measurement

The frequency stability shall be measured by variation of ambient temperature and variation of primary supply voltage to ensure that the fundamental emission stays within the authorized frequency block. The frequency stability of the transmitter shall be maintained within $\pm 0.00025\%$ ($\pm 2.5\text{ppm}$) of the center frequency.

3.8.2 Measuring Instruments

The measuring equipment is listed in the section 4 of this test report.

3.8.3 Test Procedures for Temperature Variation

1. The testing follows FCC KDB 971168 v02r01 Section 9.0.
2. The EUT was set up in the thermal chamber and connected with the system simulator.
3. With power OFF, the temperature was decreased to -30°C and the EUT was stabilized before testing. Power was applied and the maximum change in frequency was recorded within one minute.
4. With power OFF, the temperature was raised in 10°C steps up to 50°C . The EUT was stabilized at each step for at least half an hour. Power was applied and the maximum frequency change was recorded within one minute.

3.8.4 Test Procedures for Voltage Variation

1. The testing follows FCC KDB 971168 v02r01 Section 9.0.
2. The EUT was placed in a temperature chamber at $25\pm 5^{\circ}\text{C}$ and connected with the system simulator.
3. The power supply voltage to the EUT was varied from BEP to 115% of the nominal value measured at the input to the EUT.
4. The variation in frequency was measured for the worst case.

3.8.5 Test Setup

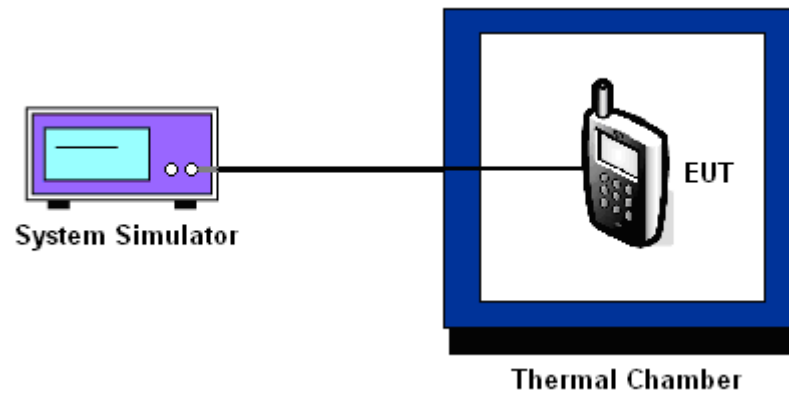



3.8.6 Test Result of Temperature Variation

Band :	GSM 850	Channel :	189
Limit (ppm) :	2.5	Frequency :	836.4 MHz

Temperature (°C)	GSM		EDGE class 8		Result
	Freq. Dev. (Hz)	Deviation (ppm)	Freq. Dev. (Hz)	Deviation (ppm)	
50	8	0.0024	6	0.0036	PASS
40	5	0.0012	5	0.0024	
30	5	0.0012	2	0.0012	
20(Ref.)	6	0.0000	3	0.0000	
10	7	0.0012	3	0.0000	
0	4	0.0024	5	0.0024	
-10	6	0.0000	7	0.0048	
-20	8	0.0024	6	0.0036	
-30	9	0.0036	7	0.0048	

Band :	GSM 1900	Channel :	661
Limit (ppm) :	within authorized band	Frequency :	1880.0 MHz

Temperature (°C)	GSM		EDGE class 8		Result
	Freq. Dev. (Hz)	Deviation (ppm)	Freq. Dev. (Hz)	Deviation (ppm)	
50	9	0.0021	12	0.0016	PASS
40	8	0.0016	10	0.0005	
30	4	0.0005	8	0.0005	
20(Ref.)	5	0.0000	9	0.0000	
10	6	0.0005	8	0.0005	
0	8	0.0016	9	0.0000	
-10	11	0.0032	12	0.0016	
-20	10	0.0027	10	0.0005	
-30	12	0.0037	14	0.0027	

Note: The frequency fundamental emissions stay within the authorized frequency block based on the frequency deviation measured is small.



Band :	WCDMA Band V	Channel :	4182
Limit (ppm) :	2.5	Frequency :	836.4 MHz

Temperature (°C)	RMC 12.2Kbps		Result
	Freq. Dev. (Hz)	Deviation (ppm)	
50	-2	0.0012	PASS
40	-2	0.0012	
30	0	0.0012	
20(Ref.)	-1	0.0000	
10	-2	0.0012	
0	1	0.0024	
-10	0	0.0012	
-20	-2	0.0012	
-30	-4	0.0036	

Band :	WCDMA Band II	Channel :	9400
Limit (ppm) :	within authorized band	Frequency :	1880.0 MHz

Temperature (°C)	RMC 12.2Kbps		Result
	Freq. Dev. (Hz)	Deviation (ppm)	
50	4	0.0016	PASS
40	3	0.0011	
30	-2	0.0016	
20(Ref.)	1	0.0000	
10	2	0.0005	
0	-1	0.0011	
-10	-2	0.0016	
-20	2	0.0005	
-30	3	0.0011	

Note: The frequency fundamental emissions stay within the authorized frequency block based on the frequency deviation measured is small.



3.8.7 Test Result of Voltage Variation

Band & Channel	Mode	Voltage (Volt)	Freq. Dev. (Hz)	Deviation (ppm)	Limit (ppm)	Result
GSM 850 CH189	GSM	3.8	4	0.0024	2.5	PASS
		BEP	6	0.0000		
		4.2	8	0.0024		
	EDGE class 8	3.8	3	0.0000		
		BEP	3	0.0000		
		4.2	5	0.0024		
GSM 1900 CH661	GSM	3.8	4	0.0005	(Note 3.)	
		BEP	5	0.0000		
		4.2	7	0.0011		
	EDGE class 8	3.8	8	0.0005		
		BEP	9	0.0000		
		4.2	12	0.0016		
WCDMA Band V CH4182	RMC 12.2Kbps	3.8	-2	0.0012	2.5	
		BEP	-1	0.0000		
		4.2	0	0.0012		
WCDMA Band II CH9400	RMC 12.2Kbps	3.8	0	0.0005	(Note 3.)	
		BEP	1	0.0000		
		4.2	-1	0.0011		

Note:

1. Normal Voltage = 3.8V.
2. Battery End Point (BEP) = 3.4 V.
3. The frequency fundamental emissions stay within the authorized frequency block based on the frequency deviation measured is small.



4 List of Measuring Equipment

Instrument	Manufacturer	Model No.	Serial No.	Characteristics	Calibration Date	Test Date	Due Date	Remark
Spectrum Analyzer	R&S	FSV40	101078	10Hz~40GHz	May 08, 2014	Sep. 26, 2014~ Sep. 27, 2014	May 07, 2015	Conducted (TH01-SZ)
Thermal Chamber	Hongzhangroup	LP-150U	HD20120425	-40°C~150°C	Feb. 21, 2014	Sep. 26, 2014~ Sep. 27, 2014	Feb. 20, 2015	Conducted (TH01-SZ)
ESCIO TEST Receiver	R&S	ESCI	100724	9kHz~3GHz	Feb. 21, 2014	Oct. 04, 2014	Feb. 20, 2015	Radiation (03CH01-SZ)
Spectrum Analyzer	Agilent Technologies	N9038A	MY52260185	20Hz~26.5GHz	May 26, 2014	Oct. 04, 2014	May 25, 2015	Radiation (03CH01-SZ)
Bilog Antenna	TESEQ	CBL 6112D	23188	30MHz~2GHz	Oct. 26, 2013	Oct. 04, 2014	Oct. 25, 2014	Radiation (03CH01-SZ)
Double Ridge Horn Antenna	ETS Lindgren	3117	00119436	1GHz~18GHz	Oct. 26, 2013	Oct. 04, 2014	Oct. 25, 2014	Radiation (03CH01-SZ)
Double Ridged Horn Antenna	COM-POWER	AH-840	101073	18GHz~40GHz	Jun. 09, 2014	Oct. 04, 2014	Jun. 08, 2015	Radiation (03CH01-SZ)
Amplifier	ADVANTEST	BB525C	E9007003	9kHz~3000MHz	Feb. 21, 2014	Oct. 04, 2014	Feb. 20, 2015	Radiation (03CH01-SZ)
Amplifier	Yiai	AV3860B	04030	2GHz~26.5GHz	May 08, 2014	Oct. 04, 2014	May 07, 2015	Radiation (03CH01-SZ)
AC Source(AVR)	Chroma	61601	616010001985	100Vac~250Vac	Mar. 25, 2014	Oct. 04, 2014	Mar. 24, 2015	Radiation (03CH01-SZ)
Turn Table	EM Electronics	EM 1000	N/A	0~360 degree	NCR	Oct. 04, 2014	NCR	Radiation (03CH01-SZ)
Antenna Mast	EM Electronics	EM 1000	N/A	1 m~4 m	NCR	Oct. 04, 2014	NCR	Radiation (03CH01-SZ)
Spectrum Analyzer	R&S	FSP 7	100818	9kHz~7GHz	Jul. 17, 2014	Sep. 29, 2014	Jul. 16, 2015	ERP/EIRP (OTA01-SZ)
Quad-Ridged Horn	ETS-Lindgren	3164-08	00102954	700MHz~10000 MHz	N/A	Sep. 29, 2014	N/A	ERP/EIRP (OTA01-SZ)
Multi-Devices Controller	ETS-Lindgren	2090-OPT1	00108147	N/A	N/A	Sep. 29, 2014	N/A	ERP/EIRP (OTA01-SZ)
Switch Control Mainframe	Agilent	3499A	MY42005451	N/A	N/A	Sep. 29, 2014	N/A	ERP/EIRP (OTA01-SZ)



5 Uncertainty of Evaluation

Uncertainty of Radiated Emission Measurement (30 MHz ~ 1000 MHz)

Measuring Uncertainty for a Level of Confidence of 95% ($U = 2Uc(y)$)	3.9
---	-----