



# RADIO TEST REPORT

Report No: STS1506010F03

Issued for

Corporativo Lanix S.A. de C.V.

Carretera Internacional Hermosillo - Nogales Km 8.5  
Hermosillo, Sonora, México

|                |                 |
|----------------|-----------------|
| Product Name:  | smart phone     |
| Brand Name:    | LANIX           |
| Model No.:     | Ilium L200      |
| Series Model:  | N/A             |
| FCC ID:        | ZC4L200         |
| Test Standard: | FCC Part 15.247 |

Any reproduction of this document must be done in full. No single part of this document may be reproduced without permission from STS, All Test Data Presented in this report is only applicable to presented Test sample.





### TEST RESULT CERTIFICATION

Applicant's name..... Corporativo Lanix S.A. de C.V.  
 Address ..... Carretera Internacional Hermosillo - Nogales Km 8.5 Hermosillo, Sonora, México  
**Manufacture's Name**..... AMER MOBILE CO.,LIMITED  
 Address ..... Room A30, 9th floor, Silvercorp International Tower No 707-713, Nathan Road, mongkok, Kowloon, Hong Kong

#### Product description

Product name ..... smart phone  
 Band name ..... LANIX  
 Model and/or type reference Ilium L200  
 .....  
 Ratings ..... DC 5V/500mA

**Standards** ..... FCC Part 15.247

Test procedure ..... ANSI C63.10-2013

This device described above has been tested by STS, and the test results show that the equipment under test (EUT) is in compliance with the FCC requirements. And it is applicable only to the tested sample identified in the report.

This report shall not be reproduced except in full, without the written approval of STS, this document may be altered or revised by STS, personal only, and shall be noted in the revision of the document.

**Date of Test** .....

Date (s) of performance of tests .. 04 June. 2015 ~10June. 2015

Date of Issue..... 11 June. 2015

Test Result..... Pass

Testing Engineer :

(Jin Ming)

Technical Manager :

(Vita Li)

Authorized Signatory :

(Bovey Yang)





| Table of Contents   | Page      |
|---|-----------|
| <b>1. SUMMARY OF TEST RESULTS</b>                           | <b>6</b>  |
| 1.1 TEST FACILITY   | 7         |
| 1.2 MEASUREMENT UNCERTAINTY                                 | 7         |
| <b>2. GENERAL INFORMATION</b>                               | <b>8</b>  |
| 2.1 GENERAL DESCRIPTION OF EUT                              | 8         |
| 2.2 DESCRIPTION OF TEST MODES                               | 10        |
| 2.3 TABLE OF PARAMETERS OF TEXT SOFTWARE SETTING            | 10        |
| 2.4 BLOCK DIGRAM SHOWING THE CONFIGURATION OF SYSTEM TESTED | 11        |
| 2.5 DESCRIPTION OF SUPPORT UNITS                            | 12        |
| 2.6 EQUIPMENTS LIST FOR ALL TEST ITEMS                      | 13        |
| <b>3. EMC EMISSION TEST</b>                                 | <b>14</b> |
| 3.1 CONDUCTED EMISSION MEASUREMENT                          | 14        |
| 3.1.1 POWER LINE CONDUCTED EMISSION LIMITS                  | 14        |
| 3.1.2 TEST PROCEDURE  | 15        |
| 3.1.3 TEST SETUP  | 15        |
| 3.1.4 EUT OPERATING CONDITIONS                              | 15        |
| 3.1.5 TEST RESULTS  | 16        |
| 3.2 RADIATED EMISSION MEASUREMENT                           | 18        |
| 3.2.1 RADIATED EMISSION LIMITS                              | 18        |
| 3.2.2 TEST PROCEDURE  | 19        |
| 3.2.3 DEVIATION FROM TEST STANDARD                          | 19        |
| 3.2.4 TEST SETUP  | 20        |
| 3.2.5 EUT OPERATING CONDITIONS                              | 21        |
| 3.2.6 TEST RESULTS  | 22        |
| <b>4. CONDUCTED SPURIOUS EMISSIONS</b>                      | <b>28</b> |
| 4.1 REQUIREMENT   | 28        |
| 4.2 TEST PROCEDURE  | 28        |
| 4.3 TEST SETUP  | 28        |
| 4.4 EUT OPERATION CONDITIONS                                | 28        |
| 4.5 TEST RESULTS  | 29        |
| <b>5. NUMBER OF HOPPING CHANNEL</b>                         | <b>38</b> |
| 5.1 APPLIED PROCEDURES / LIMIT                              | 38        |
| 5.2 TEST PROCEDURE  | 38        |
| 5.3 TEST SETUP  | 38        |
| 5.4 EUT OPERATION CONDITIONS                                | 38        |



| <b>Table of Contents</b>                         | <b>Page</b> |
|--|-------------|
| <b>5.5 TEST RESULTS</b>                          | <b>39</b>   |
| <b>6. AVERAGE TIME OF OCCUPANCY</b>              | <b>40</b>   |
| 6.1 APPLIED PROCEDURES / LIMIT                   | 40          |
| 6.2 TEST PROCEDURE                               | 40          |
| 6.3 TEST SETUP                                   | 40          |
| 6.4 EUT OPERATION CONDITIONS                     | 40          |
| 6.5 TEST RESULTS                                 | 41          |
| <b>7. HOPPING CHANNEL SEPARATION MEASUREMENT</b> | <b>47</b>   |
| 7.1 APPLIED PROCEDURES / LIMIT                   | 47          |
| 7.2 TEST PROCEDURE                               | 47          |
| 7.3 TEST SETUP                                   | 47          |
| 7.4 EUT OPERATION CONDITIONS                     | 47          |
| 7.5 TEST RESULTS                                 | 48          |
| <b>8. BANDWIDTH TEST</b>                         | <b>54</b>   |
| 8.1 APPLIED PROCEDURES / LIMIT                   | 54          |
| 8.2 TEST PROCEDURE                               | 54          |
| 8.3 TEST SETUP                                   | 54          |
| 8.4 EUT OPERATION CONDITIONS                     | 54          |
| 8.5 TEST RESULTS                                 | 55          |
| <b>9. PEAK OUTPUT POWER TEST</b>                 | <b>61</b>   |
| 9.1 APPLIED PROCEDURES / LIMIT                   | 61          |
| 9.2 TEST PROCEDURE                               | 61          |
| 9.3 TEST SETUP                                   | 61          |
| 9.4 EUT OPERATION CONDITIONS                     | 61          |
| 9.5 TEST RESULTS                                 | 62          |
| <b>10. ANTENNA REQUIREMENT</b>                   | <b>68</b>   |
| 10.1 STANDARD REQUIREMENT                        | 68          |
| 10.2 EUT ANTENNA                                 | 68          |



**Revision History**

| Rev. | Issue Date    | Report NO.    | Effect Page | Contents      |
|------|---------------|---------------|-------------|---------------|
| 00   | 11 June. 2015 | STS1506010F03 | ALL         | Initial Issue |
|      |               |               |             |               |





## 1. SUMMARY OF TEST RESULTS

Test procedures according to the technical standards:

| <b>FCC Part15 (15.247) , Subpart C</b> |                             |          |        |
|--|-----------------------------|----------|--------|
| Standard Section                       | Test Item                   | Judgment | Remark |
| 15.207                                 | Conducted Emission          | PASS     | --     |
| 15.247(a)(1)                           | Hopping Channel Separation  | PASS     | --     |
| 15.247(b)(1)                           | Peak Output Power           | PASS     | --     |
| 15.247(c)                              | Radiated Spurious Emission  | PASS     | --     |
| 15.247(d)                              | Conducted Spurious Emission | PASS     | --     |
| 15.247(a)(iii)                         | Number of Hopping Frequency | PASS     | --     |
| 15.247(a)(iii)                         | Dwell Time                  | PASS     | --     |
| 15.247(a)(1)                           | Bandwidth                   | PASS     | --     |
| 15.205                                 | Band Edge Emission          | PASS     | --     |
| 15.203                                 | Antenna Requirement         | PASS     | --     |

**NOTE:**

(1) "N/A" denotes test is not applicable in this Test Report



## 1.1 TEST FACILITY

Shenzhen STS Test Services Co., Ltd.

Add. : 1/F., Building B, Zhuoke Science Park, No.190,Chongqing Road,  
Fuyong Street, Bao'an District, Shenzhen, Guangdong,China

CNAS Registration No.: L7649;

FCC Registration No.: 842334; IC Registration No.: 12108A-1

## 1.2 MEASUREMENT UNCERTAINTY

The reported uncertainty of measurement  $y \pm U$ , where expanded uncertainty  $U$  is based on a standard uncertainty multiplied by a coverage factor of  $k=2$ , providing a level of confidence of approximately **95 %**.

| No. | Item                                       | Uncertainty               |
|-----|--|---------------------------|
| 1   | Conducted Emission (9KHz-150KHz)           | $\pm 2.88\text{dB}$       |
| 2   | Conducted Emission (150KHz-30MHz)          | $\pm 2.67\text{dB}$       |
| 3   | RF power,conducted                         | $\pm 0.70\text{dB}$       |
| 4   | Spurious emissions,conducted               | $\pm 1.19\text{dB}$       |
| 5   | All emissions,radiated(<1G) 30MHz-200MHz   | $\pm 2.83\text{dB}$       |
| 6   | All emissions,radiated(<1G) 200MHz-1000MHz | $\pm 2.94\text{dB}$       |
| 7   | All emissions,radiated(>1G)                | $\pm 3.03\text{dB}$       |
| 8   | Temperature                                | $\pm 0.5^{\circ}\text{C}$ |
| 9   | Humidity                                   | $\pm 2\%$                 |



## 2. GENERAL INFORMATION

### 2.1 GENERAL DESCRIPTION OF EUT

|                            |   |
|----------------------------|---|
| Equipment                  | smart phone   |
| Trade Name                 | LANIX   |
| Model Name                 | Ilium L200  |
| Serial Model               | N/A   |
| Model Difference           | N/A   |
| Channel List               | Please refer to the Note 2.   |
| Bluetooth                  | Frequency:2402 – 2480 MHz<br>Modulation: GFSK(1Mbps), $\pi/4$ -DQPSK(2Mbps),<br>8-DPSK(3Mbps) |
| Adapter                    | Input:AC 100-240V,50/60Hz,150mA<br>Output:DC 5V,500mA   |
| Battery                    | Rated Voltage: 3.7V<br>capacity :1600mAh  |
| Hardware version number    | WMDAb   |
| Software versioning number | --  |
| Connecting I/O Port(s)     | Please refer to the User's Manual   |

Note:

1. For a more detailed features description, please refer to the manufacturer's specifications or the User's Manual.





2.

| Channel List |                 |         |                 |         |                 |
|--------------|-----------------|---------|-----------------|---------|-----------------|
| Channel      | Frequency (MHz) | Channel | Frequency (MHz) | Channel | Frequency (MHz) |
| 00           | 2402            | 27      | 2429            | 54      | 2456            |
| 01           | 2403            | 28      | 2430            | 55      | 2457            |
| 02           | 2404            | 29      | 2431            | 56      | 2458            |
| 03           | 2405            | 30      | 2432            | 57      | 2459            |
| 04           | 2406            | 31      | 2433            | 58      | 2460            |
| 05           | 2407            | 32      | 2434            | 59      | 2461            |
| 06           | 2408            | 33      | 2435            | 60      | 2462            |
| 07           | 2409            | 34      | 2436            | 61      | 2463            |
| 08           | 2410            | 35      | 2437            | 62      | 2464            |
| 09           | 2411            | 36      | 2438            | 63      | 2465            |
| 10           | 2412            | 37      | 2439            | 64      | 2466            |
| 11           | 2413            | 38      | 2440            | 65      | 2467            |
| 12           | 2414            | 39      | 2441            | 66      | 2468            |
| 13           | 2415            | 40      | 2442            | 67      | 2469            |
| 14           | 2416            | 41      | 2443            | 68      | 2470            |
| 15           | 2417            | 42      | 2444            | 69      | 2471            |
| 16           | 2418            | 43      | 2445            | 70      | 2472            |
| 17           | 2419            | 44      | 2446            | 71      | 2473            |
| 18           | 2420            | 45      | 2447            | 72      | 2474            |
| 19           | 2421            | 46      | 2448            | 73      | 2475            |
| 20           | 2422            | 47      | 2449            | 74      | 2476            |
| 21           | 2423            | 48      | 2450            | 75      | 2477            |
| 22           | 2424            | 49      | 2451            | 76      | 2478            |
| 23           | 2425            | 50      | 2452            | 77      | 2479            |
| 24           | 2426            | 51      | 2453            | 78      | 2480            |
| 25           | 2427            | 52      | 2454            |         |                 |
| 26           | 2428            | 53      | 2455            |         |                 |

3. Table for Filed Antenna

| Ant | Brand | Model Name | Antenna Type | Connector | Gain (dBi) | NOTE       |
|-----|-------|------------|--------------|-----------|------------|------------|
| 1   | N/A   | N/A        | PIFA Antenna | N/A       | 0          | BT Antenna |

The EUT antenna is integral Antenna. no antenna other than that furnished by the responsible party shall be used with the device.



## 2.2 DESCRIPTION OF TEST MODES

To investigate the maximum EMI emission characteristics generates from EUT, the test system was pre-scanning tested base on the consideration of following EUT operation mode or test configuration mode which possible have effect on EMI emission level. Each of these EUT operation mode(s) or test configuration mode(s) mentioned above was evaluated respectively.

| Pretest Mode | Description         |
|--------------|---------------------|
| Mode 1       | CH00                |
| Mode 2       | CH39                |
| Mode 3       | CH78                |
| Mode 4       | Charging+ Link Mode |

| For Conducted Emission |                     |
|------------------------|---------------------|
| Final Test Mode        | Description         |
| Mode 4                 | Charging+ Link Mode |

| For Radiated Emission |                     |
|-----------------------|---------------------|
| Final Test Mode       | Description         |
| Mode 1                | CH00                |
| Mode 2                | CH39                |
| Mode 3                | CH78                |
| Mode 4                | Charging+ Link Mode |

Note:

- (1) The measurements are performed at the highest, middle, lowest available channels.

## 2.3 TABLE OF PARAMETERS OF TEXT SOFTWARE SETTING

During testing channel & power controlling software provided by the customer was used to control the operating channel as well as the output power level. The RF output power selection is for the setting of RF output power expected by the customer and is going to be fixed on the firmware of the final end product power parameters of FHSS

| Test software Version | Test program: N/A |          |          |
|-----------------------|-------------------|----------|----------|
| Frequency             | 2402 MHz          | 2441 MHz | 2480 MHz |
| Parameters(1Mbps)     | DEF               | DEF      | DEF      |

## 2.4 BLOCK DIGRAM SHOWING THE CONFIGURATION OF SYSTEM TESTED

During testing channel & power controlling software provided by the customer was used to control the operating channel as well as the output power level. The RF output power selection is for the setting of RF output power expected by the customer and is going to be fixed on the firmware of the final end product power parameters of FHSS

### Radiated Spurious Emission Test

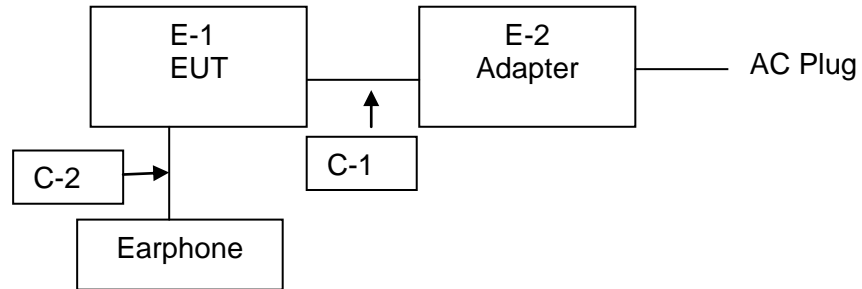

### Conducted Emission Test

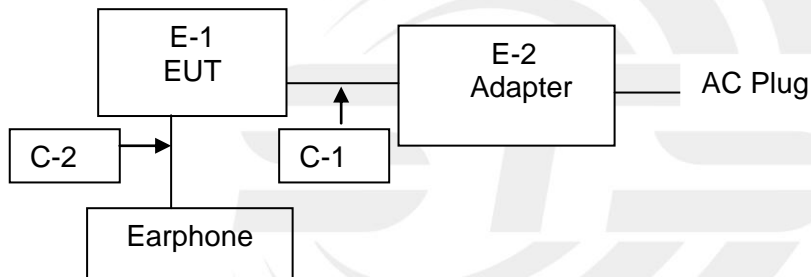



## 2.5 DESCRIPTION OF SUPPORT UNITS

The EUT has been tested as an independent unit together with other necessary accessories or support units. The following support units or accessories were used to form a representative test configuration during the tests.

| Item | Equipment   | Mfr/Brand | Model/Type No. | Series No. | Note |
|------|-------------|-----------|----------------|------------|------|
| E-1  | smart phone | LANIX     | Ilium L200     | N/A        | EUT  |
| E-2  | Adapter     | LANIX     | Ilium L200-C   | N/A        | EUT  |
| E-3  | Earphone    | N/A       | N/A            | N/A        | EUT  |
|      |             |           |                |            |      |
|      |             |           |                |            |      |
|      |             |           |                |            |      |

| Item | Shielded Type | Ferrite Core | Length | Note |
|------|---------------|--------------|--------|------|
| C-1  | unshielded    | NO           | 101cm  | N/A  |
| C-2  | unshielded    | NO           | 145cm  | N/A  |
|      |               |              |        |      |
|      |               |              |        |      |
|      |               |              |        |      |

Note:

- (1) The support equipment was authorized by Declaration of Confirmation.
- (2) For detachable type I/O cable should be specified the length in cm in 『Length』 column.
- (3) “YES” is means “shielded” “with core”; “NO” is means “unshielded” “without core”.



## 2.6 EQUIPMENTS LIST FOR ALL TEST ITEMS

## Radiation Test equipment

| Kind of Equipment   | Manufacturer | Type No.            | Serial No.    | Last calibration | Calibrated until |
|---------------------|--------------|---------------------|---------------|------------------|------------------|
| Spectrum Analyzer   | Agilent      | E4407B              | MY50140340    | 2014.10.25       | 2015.10.24       |
| Test Receiver       | R&S          | ESCI                | 101427        | 2014.10.25       | 2015.10.24       |
| Bilog Antenna       | TESEQ        | CBL6111D            | 34678         | 2014.11.25       | 2015.11.24       |
| Horn Antenna        | Schwarzbeck  | BBHA<br>9120D(1201) | 9120D-1343    | 2015.03.06       | 2016.03.05       |
| 50Ω Coaxial Switch  | Anritsu      | MP59B               | 6200264416    | 2015.06.06       | 2016.06.05       |
| PreAmplifier        | Agilent      | 8449B               | 60538         | 2014.10.25       | 2015.10.24       |
| Loop Antenna        | ARA          | PLA-1030/B          | 1029          | 2015.06.08       | 2016.06.07       |
| USB RF power sensor | DARE         | RPR3006W            | 15I00041SNO03 | 2014.10.25       | 2015.10.24       |

## Conduction Test equipment

| Kind of Equipment | Manufacturer | Type No. | Serial No. | Last calibration | Calibrated until |
|-------------------|--------------|----------|------------|------------------|------------------|
| EMI Test Receiver | R&S          | ESPI     | 102086     | 2014.11.20       | 2015.11.19       |
| LISN              | R&S          | ENV216   | 101242     | 2014.10.25       | 2015.10.24       |



### 3. EMC EMISSION TEST

#### 3.1 CONDUCTED EMISSION MEASUREMENT

##### 3.1.1 POWER LINE CONDUCTED EMISSION LIMITS

Operating frequency band. In case the emission fall within the restricted band specified on Part 15.247&207(a) limit in the table below has to be followed.

| FREQUENCY (MHz) | Class B (dBuV) |           | Standard |
|-----------------|----------------|-----------|----------|
|                 | Quasi-peak     | Average   |          |
| 0.15 -0.5       | 66 - 56 *      | 56 - 46 * | CISPR    |
| 0.50 -5.0       | 56.00          | 46.00     | CISPR    |
| 5.0 -30.0       | 60.00          | 50.00     | CISPR    |

|           |           |           |     |
|-----------|-----------|-----------|-----|
| 0.15 -0.5 | 66 - 56 * | 56 - 46 * | FCC |
| 0.50 -5.0 | 56.00     | 46.00     | FCC |
| 5.0 -30.0 | 60.00     | 50.00     | FCC |

Note:

- (1) The tighter limit applies at the band edges.
- (2) The limit of " \* " marked band means the limitation decreases linearly with the logarithm of the frequency in the range.

The following table is the setting of the receiver

| Receiver Parameters | Setting  |
|---------------------|----------|
| Attenuation         | 10 dB    |
| Start Frequency     | 0.15 MHz |
| Stop Frequency      | 30 MHz   |
| IF Bandwidth        | 9 kHz    |

### 3.1.2 TEST PROCEDURE

- a. The EUT was placed 0.4 meters from the horizontal ground plane with EUT being connected to the power mains through a line impedance stabilization network (LISN). All other support equipments powered from additional LISN(s). The LISN provide 50 Ohm/ 50uH of coupling impedance for the measuring instrument.
- b. Interconnecting cables that hang closer than 40 cm to the ground plane shall be folded back and forth in the center forming a bundle 30 to 40 cm long.
- c. I/O cables that are not connected to a peripheral shall be bundled in the center. The end of the cable may be terminated, if required, using the correct terminating impedance. The overall length shall not exceed 1 m.
- d. LISN at least 80 cm from nearest part of EUT chassis.
- e. For the actual test configuration, please refer to the related Item –EUT Test Photos.

### 3.1.3 TEST SETUP

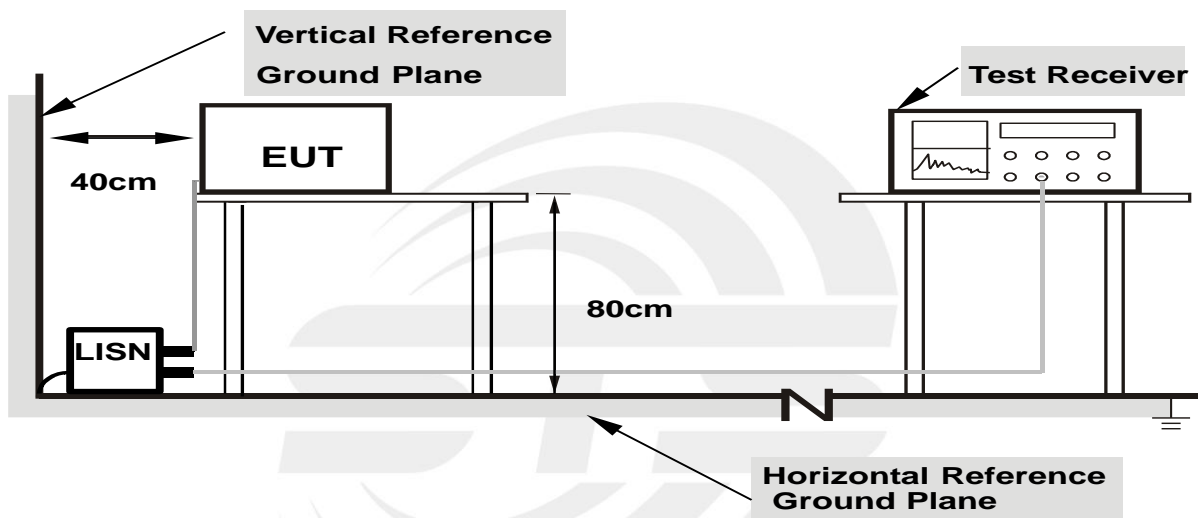

- Note: 1.Support units were connected to second LISN.**  
**2.Both of LISNs (AMN) are 80 cm from EUT and at least 80 from other units and other metal planes**

### 3.1.4 EUT OPERATING CONDITIONS

The EUT was configured for testing in a typical fashion (as a customer would normally use it). The EUT has been programmed to continuously transmit during test. This operating condition was tested and used to collect the included data.



3.1.5 TEST RESULTS

|               |                                   |                    |            |
|---------------|-----------------------------------|--------------------|------------|
| EUT:          | smart phone                       | Model Name.:       | Ilium L200 |
| Temperature:  | 26 °C                             | Relative Humidity: | 54%        |
| Pressure:     | 1010hPa                           | Phase:             | L          |
| Test Voltage: | DC 5V from Adapter<br>AC120V/60Hz | Test Mode:         | Mode 4     |

| Frequency (MHz) | Reading (dBuV) | Correct Factor(dB) | Result (dBuV) | Limit (dBuV) | Margin (dB) | Remark |
|-----------------|----------------|--------------------|---------------|--------------|-------------|--------|
| 0.1988          | 33.08          | 10.00              | 43.08         | 63.66        | -20.58      | QP     |
| 0.1988          | 19.39          | 10.00              | 29.39         | 53.66        | -24.27      | AVG    |
| 0.2972          | 32.08          | 9.90               | 41.98         | 60.32        | -18.34      | QP     |
| 0.2972          | 25.69          | 9.90               | 35.59         | 50.32        | -14.73      | AVG    |
| 0.6476          | 26.14          | 9.97               | 36.11         | 56.00        | -19.89      | QP     |
| 0.6476          | 19.70          | 9.97               | 29.67         | 46.00        | -16.33      | AVG    |
| 1.9927          | 20.90          | 10.00              | 30.90         | 56.00        | -25.10      | QP     |
| 1.9927          | 6.54           | 10.00              | 16.54         | 46.00        | -29.46      | AVG    |
| 3.4722          | 27.19          | 10.17              | 37.36         | 56.00        | -18.64      | QP     |
| 3.4722          | 12.09          | 10.17              | 22.26         | 46.00        | -23.74      | AVG    |
| 26.4663         | 26.28          | 10.55              | 36.83         | 60.00        | -23.17      | QP     |
| 26.4663         | 15.23          | 10.55              | 25.78         | 50.00        | -24.22      | AVG    |

Remark:

1. Factor = Antenna Factor + Cable Loss – Pre-amplifier.

100.0 dBuV

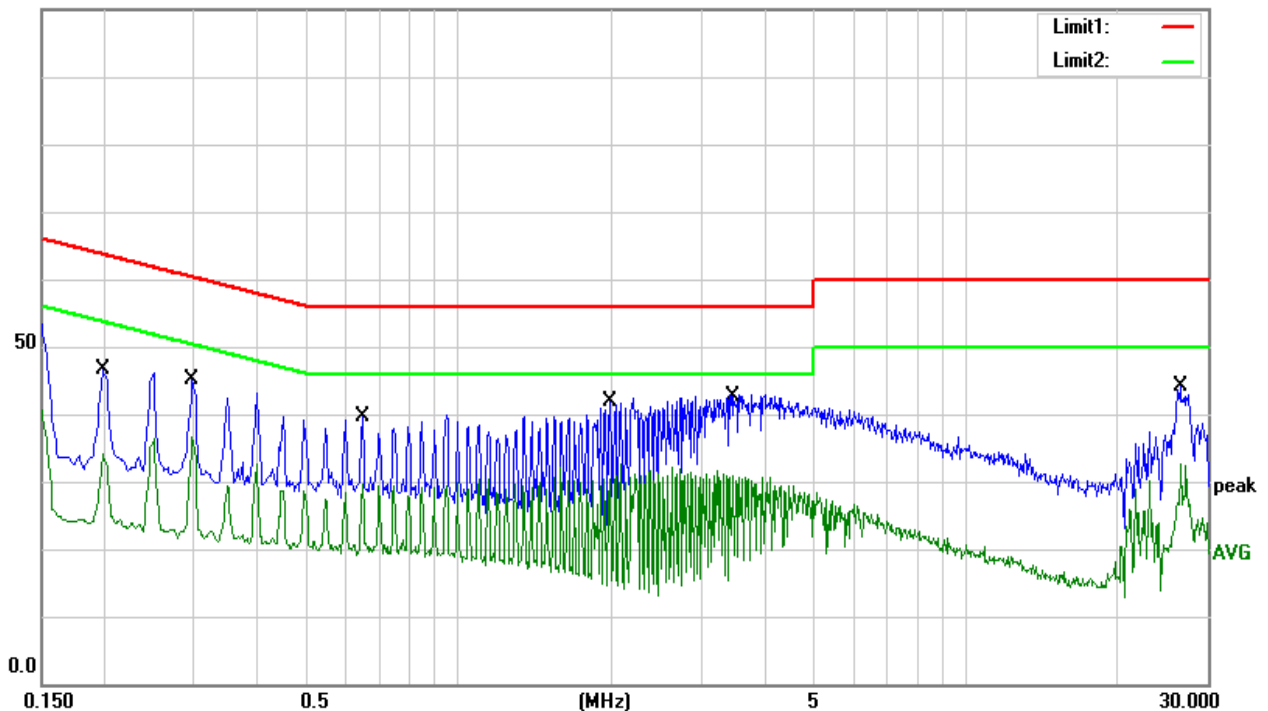





|               |                                   |                    |            |
|---------------|-----------------------------------|--------------------|------------|
| EUT:          | smart phone                       | Model Name.:       | Ilium L200 |
| Temperature:  | 26 °C                             | Relative Humidity: | 54%        |
| Pressure:     | 1010hPa                           | Phase:             | N          |
| Test Voltage: | DC 5V from Adapter<br>AC120V/60Hz | Test Mode:         | Mode 4     |

| Frequency (MHz) | Reading (dBUV) | Correct Factor(dB) | Result (dBUV) | Limit (dBUV) | Margin (dB) | Remark |
|-----------------|----------------|--------------------|---------------|--------------|-------------|--------|
| 0.2975          | 33.57          | 9.90               | 43.47         | 60.31        | -16.84      | QP     |
| 0.2975          | 29.80          | 9.90               | 39.70         | 50.31        | -10.61      | AVG    |
| 0.3957          | 31.53          | 10.00              | 41.53         | 57.94        | -16.41      | QP     |
| 0.3957          | 21.01          | 10.00              | 31.01         | 47.94        | -16.93      | AVG    |
| 0.9410          | 31.39          | 10.00              | 41.39         | 56.00        | -14.61      | QP     |
| 0.9410          | 23.92          | 10.00              | 33.92         | 46.00        | -12.08      | AVG    |
| 2.0818          | 32.99          | 10.00              | 42.99         | 56.00        | -13.01      | QP     |
| 2.0818          | 17.99          | 10.00              | 27.99         | 46.00        | -18.01      | AVG    |
| 3.3195          | 30.36          | 10.10              | 40.46         | 56.00        | -15.54      | QP     |
| 3.3195          | 14.91          | 10.10              | 25.01         | 46.00        | -20.99      | AVG    |
| 26.1900         | 24.28          | 10.73              | 35.01         | 60.00        | -24.99      | QP     |
| 26.1900         | 14.86          | 10.73              | 25.59         | 50.00        | -24.41      | AVG    |

Remark:

1. Factor = Antenna Factor + Cable Loss – Pre-amplifier.

100.0 dBUV

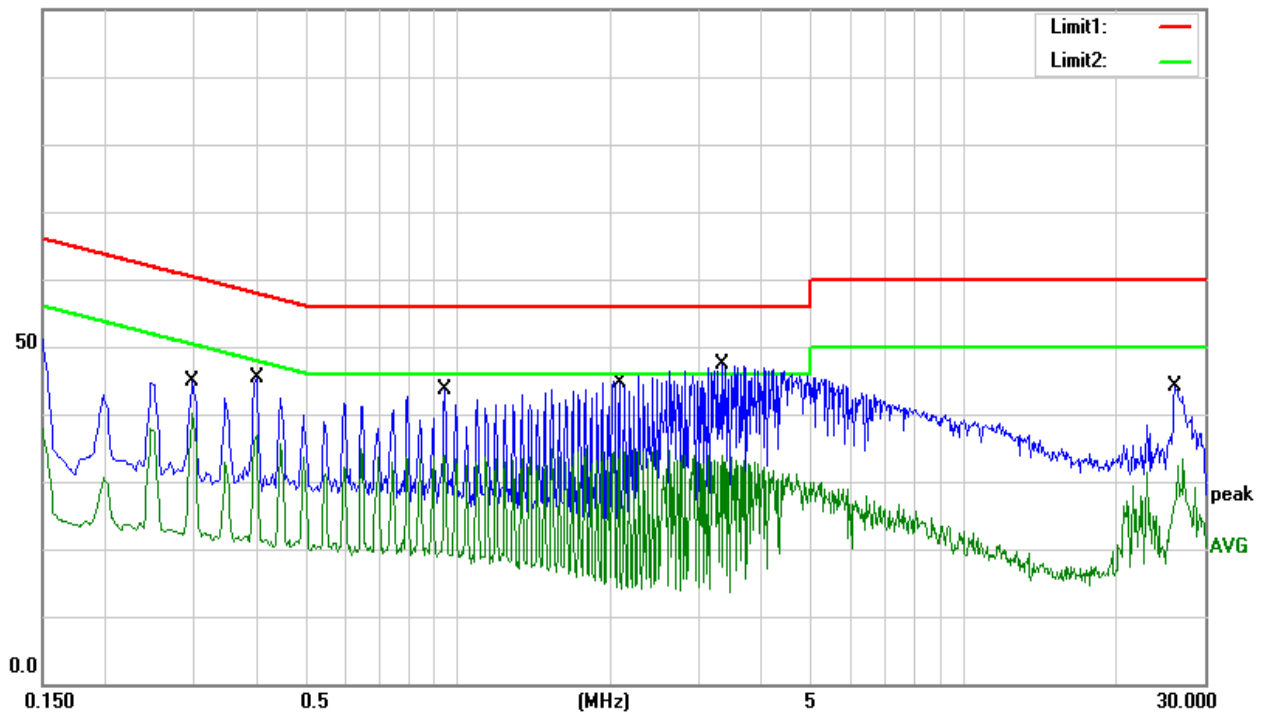



### 3.2 RADIATED EMISSION MEASUREMENT

#### 3.2.1 RADIATED EMISSION LIMITS

20dBc in any 100 kHz bandwidth outside the operating frequency band. In case the emission fall within the restricted band specified on Part 15247&205(a), then the Part 15 247&209(a) limit in the table below has to be followed.

##### LIMITS OF RADIATED EMISSION MEASUREMENT (30MHz - 1000MHz)

| Frequencies (MHz) | Field Strength (microrvolts/meter) | Measurement Distance (meters) |
|-------------------|------------------------------------|-------------------------------|
| 0.009~0.490       | 2400/F(KHz)                        | 300                           |
| 0.490~1.705       | 24000/F(KHz)                       | 30                            |
| 1.705~30.0        | 30                                 | 30                            |
| 30~88             | 100                                | 3                             |
| 88~216            | 150                                | 3                             |
| 216~960           | 200                                | 3                             |
| Above 960         | 500                                | 3                             |

##### LIMITS OF RADIATED EMISSION MEASUREMENT (Above 1000MHz)

| FREQUENCY (MHz) | Class B (dBuV/m) (at 3M) |         |
|-----------------|--------------------------|---------|
|                 | PEAK                     | AVERAGE |
| Above 1000      | 74                       | 54      |

Notes:

- (1) The limit for radiated test was performed according to FCC PART 15C.
- (2) The tighter limit applies at the band edges.
- (3) Emission level (dBuV/m)=20log Emission level (uV/m).

##### FREQUENCY RANGE OF RADIATED MEASUREMENT (For unintentional radiators)

| Highest frequency generated or Upper frequency of measurement used in the device or on which the device operates or tunes (MHz) | Range (MHz)   |
|---|---|
| Below 1.705   | 30  |
| 1.705 – 108   | 1000  |
| 108 – 500   | 2000  |
| 500 – 1000  | 5000  |
| Above 1000  | 5 <sup>th</sup> harmonic of the highest frequency or 40 GHz, whichever is lower |



| Spectrum Parameter                    | Setting                        |
|---------------------------------------|--------------------------------|
| Attenuation                           | Auto                           |
| Detector                              | Peak                           |
| Start Frequency                       | 1000 MHz(Peak/AV)              |
| Stop Frequency                        | 10th carrier harmonic(Peak/AV) |
| RB / VB (emission in restricted band) | 1 MHz / 1 MHz, AV=1 MHz / 10Hz |

| Receiver Parameter     | Setting                          |
|------------------------|----------------------------------|
| Attenuation            | Auto                             |
| Start ~ Stop Frequency | 9kHz~150kHz / RB 200Hz for QP    |
| Start ~ Stop Frequency | 150kHz~30MHz / RB 9kHz for QP    |
| Start ~ Stop Frequency | 30MHz~1000MHz / RB 120kHz for QP |

### 3.2.2 TEST PROCEDURE

- The measuring distance of at 3 m shall be used for measurements at frequency up to 1GHz. For frequencies above 1GHz, any suitable measuring distance may be used.
- The EUT was placed on the top of a rotating table 0.8 meters(above 1GHz is 1.5 m) above the ground at a 3 meter open area test site. The table was rotated 360 degrees to determine the position of the highest radiation.
- The height of the equipment or of the substitution antenna shall be 0.8 m(above 1GHz is 1.5 m); the height of the test antenna shall vary between 1 m to 4 m. Both horizontal and vertical polarizations of the antenna are set to make the measurement.
- The initial step in collecting conducted emission data is a spectrum analyzer peak detector mode pre-scanning the measurement frequency range. Significant peaks are then marked and then Quasi Peak detector mode re-measured.
- If the Peak Mode measured value compliance with and lower than Quasi Peak Mode Limit, the EUT shall be deemed to meet QP Limits and then no additional QP Mode measurement performed.
- For the actual test configuration, please refer to the related Item –EUT Test Photos.

Note:

Both horizontal and vertical antenna polarities were tested and performed pretest to three orthogonal axis. The worst case emissions were reported

### 3.2.3 DEVIATION FROM TEST STANDARD

No deviation

### 3.2.4 TEST SETUP

(A) Radiated Emission Test-Up Frequency Below 30MHz

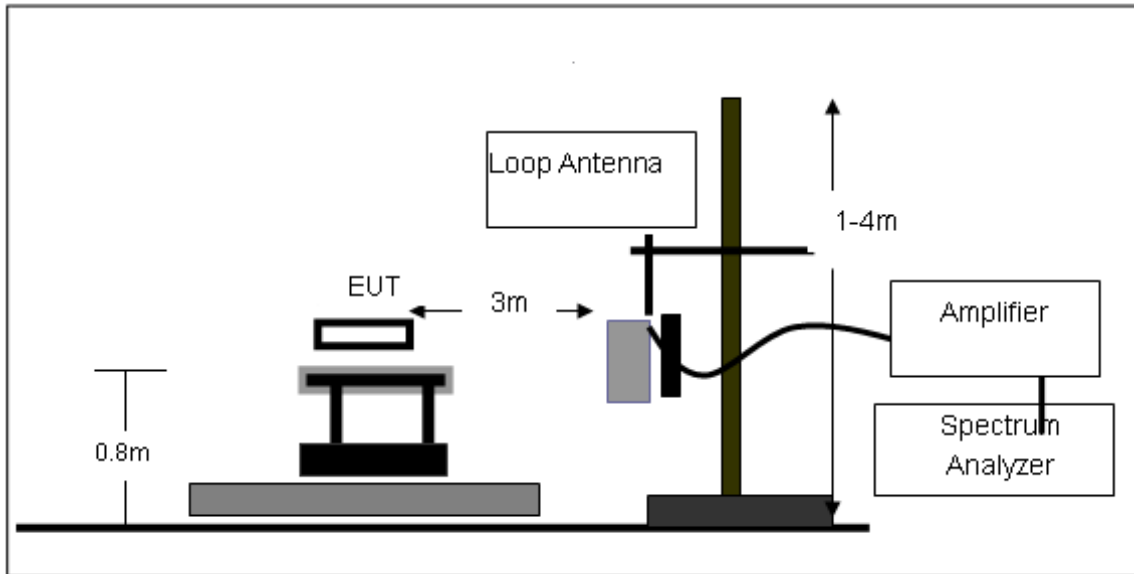

(B) Radiated Emission Test-Up Frequency 30MHz~1GHz

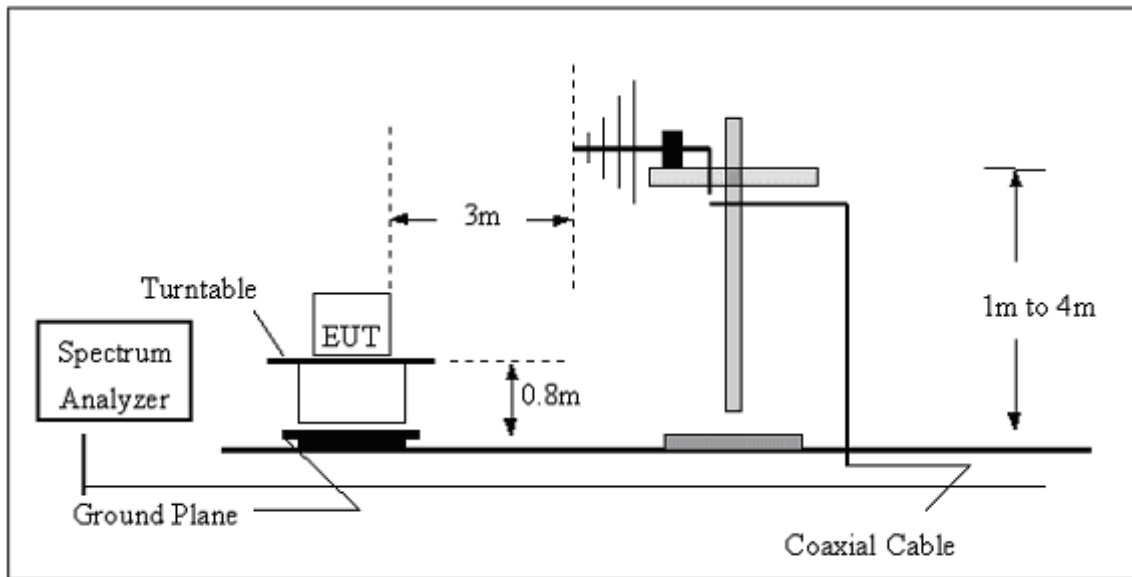

## (C) Radiated Emission Test-Up Frequency Above 1GHz

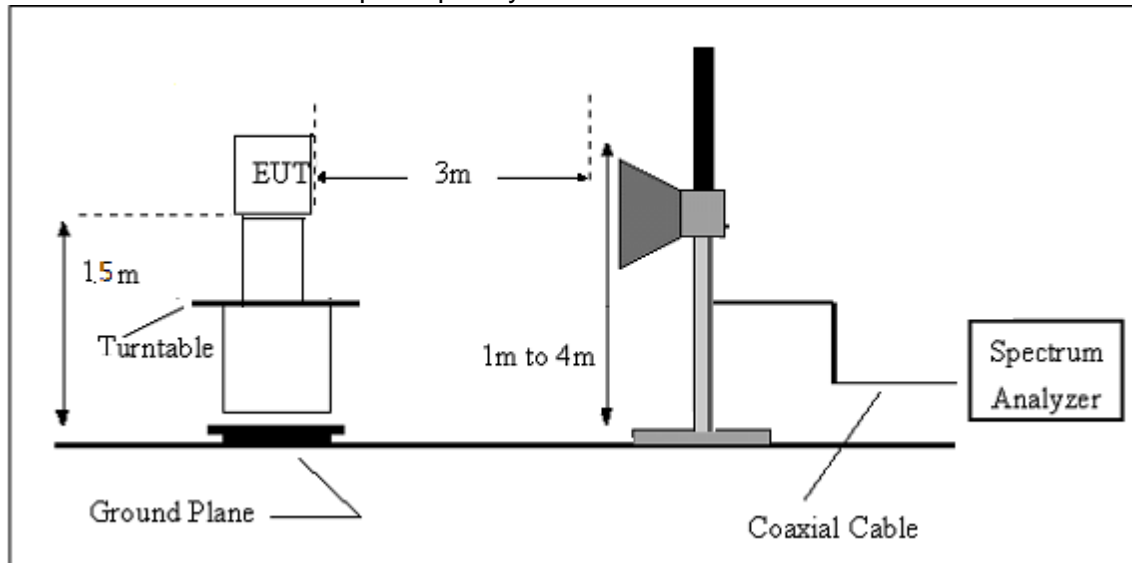

### 3.2.5 EUT OPERATING CONDITIONS

The EUT tested system was configured as the statements of 2.4 Unless otherwise a special operating condition is specified in the follows during the testing.



### 3.2.6 TEST RESULTS

Below 30MHz

|               |                                   |                    |            |
|---------------|-----------------------------------|--------------------|------------|
| EUT:          | smart phone                       | Model Name.:       | Ilium L200 |
| Temperature:  | 26 °C                             | Relative Humidity: | 54%        |
| Pressure:     | 1010hPa                           | Phase:             | Horizontal |
| Test Voltage: | DC 5V from Adapter<br>AC120V/60Hz | Test Mode:         | N/A        |

| Freq.<br>(MHz) | Reading<br>(dBuV/m) | Limit<br>(dBuV/m) | Margin<br>(dB) | State<br>P/F | Test Result |
|----------------|---------------------|-------------------|----------------|--------------|-------------|
| --             | --                  | --                | --             | --           | PASS        |
| --             | --                  | --                | --             | --           | PASS        |

**NOTE:**

The amplitude of spurious emissions which are attenuated by more than 20dB below the permissible value has no need to be reported.

Distance extrapolation factor =  $40 \log(\text{specific distance}/\text{test distance})$ (dB);

Limit line = specific limits(dBuV) + distance extrapolation factor.

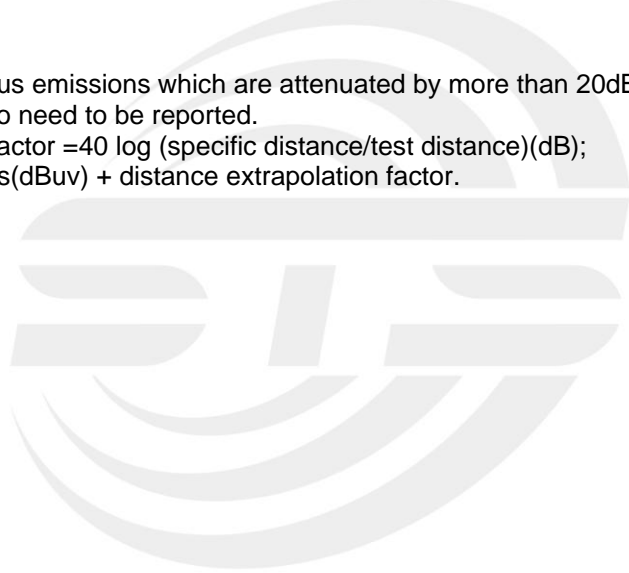



Between 30-1000MHz

|               |                                 |                    |            |
|---------------|---------------------------------|--------------------|------------|
| EUT:          | smart phone                     | Model Name.:       | Ilium L200 |
| Temperature:  | 26 °C                           | Relative Humidity: | 54%        |
| Pressure:     | 1010hPa                         | Phase:             | Horizontal |
| Test Voltage: | DC 5V from Adapter AC 120V/60Hz | Test Mode:         | Mode 4     |

| Frequency (MHz) | Reading (dBuV) | Correct Factor(dB/m) | Result (dBuV/m) | Limit (dBuV/m) | Margin (dB) | Remark |
|-----------------|----------------|----------------------|-----------------|----------------|-------------|--------|
| 30.0000         | 5.57           | 18.71                | 24.28           | 40.00          | -15.72      | QP     |
| 60.4920         | 15.58          | 5.36                 | 20.94           | 40.00          | -19.06      | QP     |
| 84.4054         | 11.32          | 8.68                 | 20.00           | 40.00          | -20.00      | QP     |
| 175.0367        | 9.56           | 10.24                | 19.80           | 43.50          | -23.70      | QP     |
| 248.5518        | 7.44           | 13.42                | 20.86           | 46.00          | -25.14      | QP     |
| 614.2142        | 7.45           | 22.46                | 29.91           | 46.00          | -16.09      | QP     |

Remark:

1. Factor = Antenna Factor + Cable Loss – Pre-amplifier.

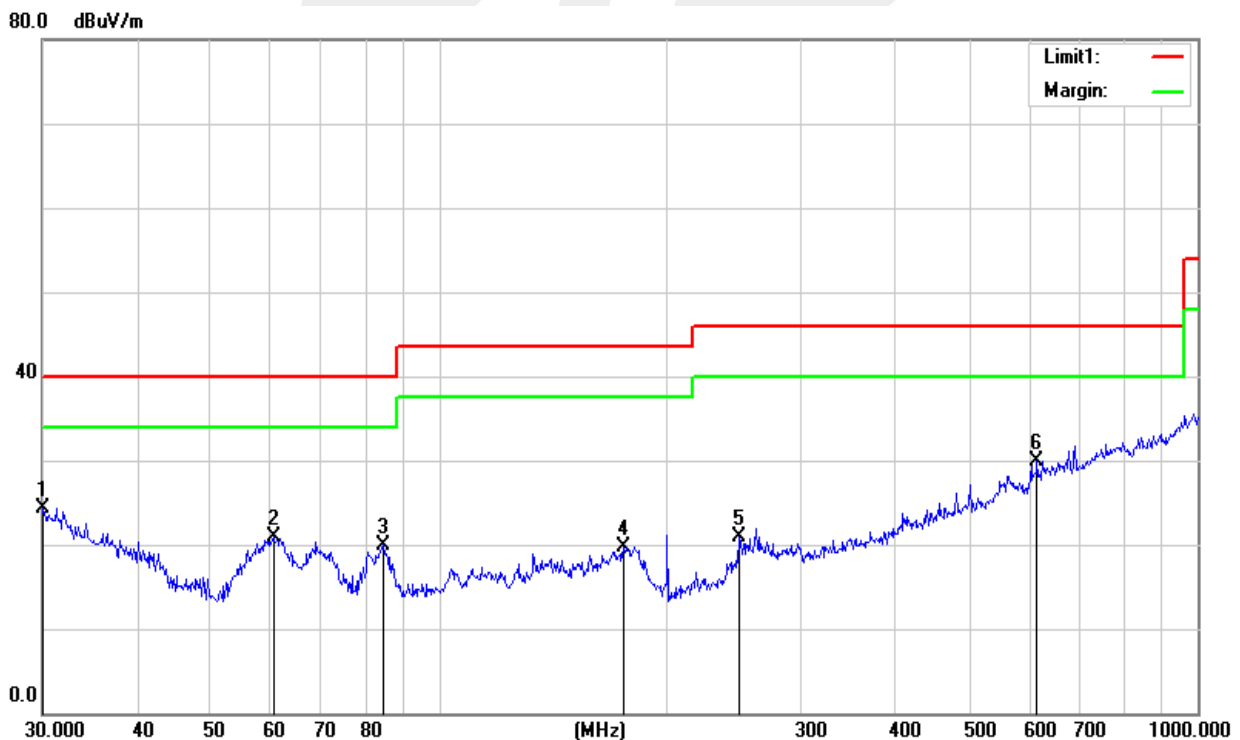



|               |                                 |                    |            |
|---------------|---------------------------------|--------------------|------------|
| EUT:          | smart phone                     | Model Name.:       | Ilium L200 |
| Temperature:  | 26 °C                           | Relative Humidity: | 54%        |
| Pressure:     | 1010hPa                         | Phase:             | Vertical   |
| Test Voltage: | DC 5V from Adapter AC 120V/60Hz | Test Mode:         | Mode 4     |

| Frequency (MHz) | Reading (dBuV) | Correct Factor(dB/m) | Result (dBuV/m) | Limit (dBuV/m) | Margin (dB) | Remark |
|-----------------|----------------|----------------------|-----------------|----------------|-------------|--------|
| 31.6202         | 16.95          | 17.85                | 34.80           | 40.00          | -5.20       | QP     |
| 36.8952         | 17.65          | 15.08                | 32.73           | 40.00          | -7.27       | QP     |
| 81.2116         | 15.02          | 8.19                 | 23.21           | 40.00          | -16.79      | QP     |
| 143.8294        | 7.87           | 12.32                | 20.19           | 43.50          | -23.31      | QP     |
| 281.9945        | 6.04           | 14.14                | 20.18           | 46.00          | -25.82      | QP     |
| 609.9215        | 7.83           | 22.47                | 30.30           | 46.00          | -15.70      | QP     |

Remark:

- Factor = Antenna Factor + Cable Loss – Pre-amplifier.

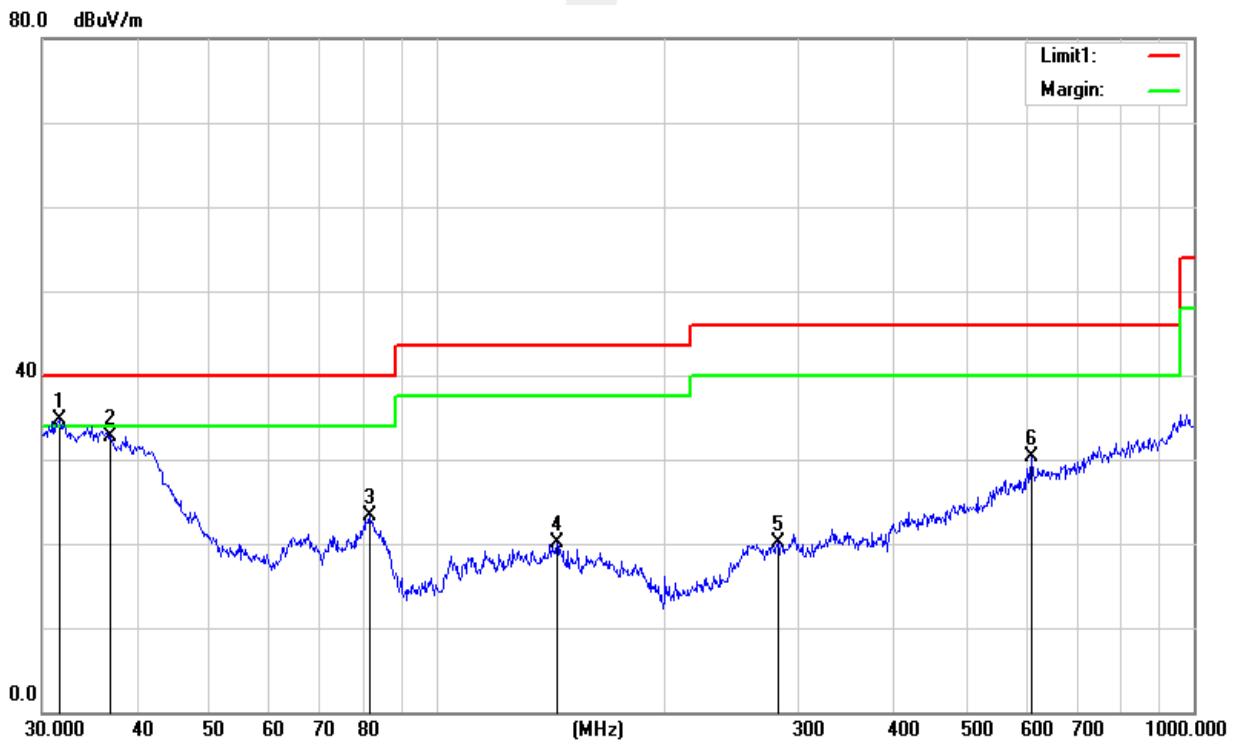





Above 1000 MHz

| Frequency (MHz)         | Meter Reading (dB $\mu$ V) | Factor (dB) | Emission Level (dB $\mu$ V/m) | Limits (dB $\mu$ V/m) | Margin (dB) | Detector Type | Comment    |
|-------------------------|----------------------------|-------------|-------------------------------|-----------------------|-------------|---------------|------------|
| Low Channel (2402 MHz)  |                            |             |                               |                       |             |               |            |
| 4804.20                 | 68.51                      | -3.62       | 64.89                         | 74                    | -9.11       | PK            | Vertical   |
| 4804.22                 | 54.19                      | -3.62       | 50.57                         | 54                    | -3.43       | AV            | Vertical   |
| 7206.13                 | 69.82                      | -0.9        | 68.92                         | 74                    | -5.08       | PK            | Vertical   |
| 7206.12                 | 53.31                      | -0.9        | 52.41                         | 54                    | -1.59       | AV            | Vertical   |
| 4804.00                 | 70.34                      | -3.65       | 66.69                         | 74                    | -7.31       | PK            | Horizontal |
| 4803.98                 | 53.37                      | -3.65       | 49.72                         | 54                    | -4.28       | AV            | Horizontal |
| Mid Channel (2441 MHz)  |                            |             |                               |                       |             |               |            |
| 4882.08                 | 64.69                      | -3.65       | 61.04                         | 74                    | -12.96      | PK            | Vertical   |
| 4882.07                 | 49.48                      | -3.65       | 45.83                         | 54                    | -8.17       | AV            | Vertical   |
| 7323.21                 | 60.89                      | -0.84       | 60.05                         | 74                    | -13.95      | PK            | Vertical   |
| 7323.20                 | 44.40                      | -0.84       | 43.56                         | 54                    | -10.44      | AV            | Vertical   |
| 4882.18                 | 61.33                      | -3.68       | 57.65                         | 74                    | -16.35      | PK            | Horizontal |
| 4882.15                 | 44.96                      | -3.68       | 41.28                         | 54                    | -12.72      | AV            | Horizontal |
| High Channel (2480 MHz) |                            |             |                               |                       |             |               |            |
| 4960.26                 | 60.93                      | -3.59       | 57.34                         | 74                    | -16.66      | PK            | Vertical   |
| 4960.31                 | 45.50                      | -3.59       | 41.91                         | 54                    | -12.09      | AV            | Vertical   |
| 7440.32                 | 60.86                      | -0.83       | 60.03                         | 74                    | -13.97      | PK            | Vertical   |
| 7440.31                 | 45.28                      | -0.83       | 44.45                         | 54                    | -9.55       | AV            | Vertical   |
| 4960.33                 | 60.88                      | -3.59       | 57.29                         | 74                    | -16.71      | PK            | Horizontal |
| 4960.30                 | 45.30                      | -3.59       | 41.71                         | 54                    | -12.29      | AV            | Horizontal |

Note:

- 1) 30MHz~25GHz:(Scan with GFSK,  $\pi/4$ -DQPSK,8DPSK, the worst casw is GFSK Mode)
- 2) Factor = Antenna Factor + Cable Loss – Pre-amplifier.  
Emission Level = Meter Reading + Factor  
Margin = Limit - Emission Leve



Band edge

| Frequency (MHz) | Meter Reading (dBμV) | Factor (dB) | Emission Level (dBμV/m) | Limits (dBμV/m) | Margin (dB) | Detector Type | Comment    |
|-----------------|----------------------|-------------|-------------------------|-----------------|-------------|---------------|------------|
| GFSK            |                      |             |                         |                 |             |               |            |
| 2399.9          | 70.73                | -12.99      | 57.74                   | 74              | -16.26      | PK            | Vertical   |
| 2399.9          | 53.87                | -12.99      | 40.88                   | 54              | -13.12      | AV            | Vertical   |
| 2399.9          | 69.56                | -12.99      | 56.57                   | 74              | -17.43      | PK            | Horizontal |
| 2399.9          | 54.32                | -12.99      | 41.33                   | 54              | -12.67      | AV            | Horizontal |
| 2483.6          | 70.93                | -12.78      | 58.15                   | 74              | -15.85      | PK            | Vertical   |
| 2483.6          | 55.41                | -12.78      | 42.63                   | 54              | -11.37      | AV            | Vertical   |
| 2483.6          | 70.45                | -12.78      | 57.67                   | 74              | -16.33      | PK            | Horizontal |
| 2483.6          | 54.09                | -12.78      | 41.31                   | 54              | -12.69      | AV            | Horizontal |
| π/4-DQPSK       |                      |             |                         |                 |             |               |            |
| 2399.9          | 70.90                | -12.99      | 57.91                   | 74              | -16.09      | PK            | Vertical   |
| 2399.9          | 53.74                | -12.99      | 40.75                   | 54              | -13.25      | AV            | Vertical   |
| 2399.9          | 69.29                | -12.99      | 56.3                    | 74              | -17.7       | PK            | Horizontal |
| 2399.9          | 54.54                | -12.99      | 41.55                   | 54              | -12.45      | AV            | Horizontal |
| 2483.6          | 70.67                | -12.78      | 57.89                   | 74              | -16.11      | PK            | Vertical   |
| 2483.6          | 55.30                | -12.78      | 42.52                   | 54              | -11.48      | AV            | Vertical   |
| 2483.6          | 70.55                | -12.78      | 57.77                   | 74              | -16.23      | PK            | Horizontal |
| 2483.6          | 54.09                | -12.78      | 41.31                   | 54              | -12.69      | AV            | Horizontal |
| 8DPSK           |                      |             |                         |                 |             |               |            |
| 2399.9          | 70.88                | -12.99      | 57.89                   | 74              | -16.11      | PK            | Vertical   |
| 2399.9          | 54.86                | -12.99      | 41.87                   | 54              | -12.13      | AV            | Vertical   |
| 2399.9          | 69.87                | -12.99      | 56.88                   | 74              | -17.12      | PK            | Horizontal |
| 2399.9          | 55.66                | -12.99      | 42.67                   | 54              | -11.33      | AV            | Horizontal |
| 2483.6          | 70.55                | -12.78      | 57.77                   | 74              | -16.23      | PK            | Vertical   |
| 2483.6          | 54.35                | -12.78      | 41.57                   | 54              | -12.43      | AV            | Vertical   |
| 2483.6          | 70.60                | -12.78      | 57.82                   | 74              | -16.18      | PK            | Horizontal |
| 2483.6          | 54.02                | -12.78      | 41.24                   | 54              | -12.76      | AV            | Horizontal |

Low measurement frequencies is range from 2310 to 2400 MHz, high measurement frequencies is range from 2483.5 to 2500 MHz.

Only show the worst point data of the emissions in the frequency 2310-2400 MHz and 2483.5-2500 MHz.



## Hopping

| Frequency (MHz) | Meter Reading (dB $\mu$ V) | Factor (dB) | Emission Level (dB $\mu$ V/m) | Limits (dB $\mu$ V/m) | Margin (dB) | Detector Type | Comment    |
|-----------------|----------------------------|-------------|-------------------------------|-----------------------|-------------|---------------|------------|
| GFSK            |                            |             |                               |                       |             |               |            |
| 2390            | 68.59                      | -12.99      | 55.6                          | 74                    | -18.4       | PK            | Vertical   |
| 2390            | 54.72                      | -12.99      | 41.73                         | 54                    | -12.27      | AV            | Vertical   |
| 2390            | 67.68                      | -12.99      | 54.69                         | 74                    | -19.31      | PK            | Horizontal |
| 2390            | 53.63                      | -12.99      | 40.64                         | 54                    | -13.36      | AV            | Horizontal |
| 2483.5          | 66.53                      | -12.78      | 53.75                         | 74                    | -20.25      | PK            | Vertical   |
| 2483.5          | 54.48                      | -12.78      | 41.7                          | 54                    | -12.3       | AV            | Vertical   |
| 2483.5          | 67.47                      | -12.78      | 54.69                         | 74                    | -19.31      | PK            | Horizontal |
| 2483.5          | 54.40                      | -12.78      | 41.62                         | 54                    | -12.38      | AV            | Horizontal |
| $\pi/4$ -DQPSK  |                            |             |                               |                       |             |               |            |
| 2390            | 68.14                      | -12.99      | 55.15                         | 74                    | -18.85      | PK            | Vertical   |
| 2390            | 55.48                      | -12.99      | 42.49                         | 54                    | -11.51      | AV            | Vertical   |
| 2390            | 67.26                      | -12.99      | 54.27                         | 74                    | -19.73      | PK            | Horizontal |
| 2390            | 53.62                      | -12.99      | 40.63                         | 54                    | -13.37      | AV            | Horizontal |
| 2483.5          | 67.52                      | -12.78      | 54.74                         | 74                    | -19.26      | PK            | Vertical   |
| 2483.5          | 53.52                      | -12.78      | 40.74                         | 54                    | -13.26      | AV            | Vertical   |
| 2483.5          | 68.51                      | -12.78      | 55.73                         | 74                    | -18.27      | PK            | Horizontal |
| 2483.5          | 54.40                      | -12.78      | 41.62                         | 54                    | -12.38      | AV            | Horizontal |
| 8DPSK           |                            |             |                               |                       |             |               |            |
| 2390            | 68.30                      | -12.99      | 55.31                         | 74                    | -18.69      | PK            | Vertical   |
| 2390            | 54.24                      | -12.99      | 41.25                         | 54                    | -12.75      | AV            | Vertical   |
| 2390            | 67.58                      | -12.99      | 54.59                         | 74                    | -19.41      | PK            | Horizontal |
| 2390            | 54.54                      | -12.99      | 41.55                         | 54                    | -12.45      | AV            | Horizontal |
| 2483.5          | 68.25                      | -12.78      | 55.47                         | 74                    | -18.53      | PK            | Vertical   |
| 2483.5          | 54.37                      | -12.78      | 41.59                         | 54                    | -12.41      | AV            | Vertical   |
| 2483.5          | 67.42                      | -12.78      | 54.64                         | 74                    | -19.36      | PK            | Horizontal |
| 2483.5          | 54.39                      | -12.78      | 41.61                         | 54                    | -12.39      | AV            | Horizontal |

Low measurement frequencies is range from 2310 to 2400 MHz, high measurement frequencies is range from 2483.5 to 2500 MHz.

Only show the worst point data of the emissions in the frequency 2310-2400 MHz and 2483.5-2500 MHz.

#### 4. CONDUCTED SPURIOUS EMISSIONS

##### 4.1 REQUIREMENT

According to FCC section 15.247(d), in any 100kHz bandwidth outside the frequency band in which the spread spectrum or digitally modulated intentional radiator is operating, the radio frequency power that is produced by the intentional radiator shall be at least 20dB below that in the 100kHz bandwidth within the band that contains the highest level of the desired power, based on either an RF conducted or a radiated measurement.

##### 4.2 TEST PROCEDURE

According to FCC section 15.247(d), in any 100kHz bandwidth outside the frequency band in which the spread spectrum or digitally modulated intentional radiator is operating, the radio frequency power that is produced by the intentional radiator shall be at least 20dB below that in the 100kHz bandwidth within the band that contains the highest level of the desired power, based on either an RF conducted or a radiated measurement.

| Spectrum Parameter                    | Setting                         |
|---------------------------------------|---------------------------------|
| Detector                              | Peak                            |
| Start/Stop Frequency                  | 30 MHz to 10th carrier harmonic |
| RB / VB (emission in restricted band) | 100 KHz/300 KHz                 |
| Trace-Mode:                           | Max hold                        |

For Band edge

| Spectrum Parameter                    | Setting  |
|---------------------------------------|--|
| Detector                              | Peak   |
| Start/Stop Frequency                  | Lower Band Edge: 2310 – 2404 MHz<br>Upper Band Edge: 2478 – 2500 MHz |
| RB / VB (emission in restricted band) | 100 KHz/300 KHz  |
| Trace-Mode:                           | Max hold   |

##### 4.3 TEST SETUP

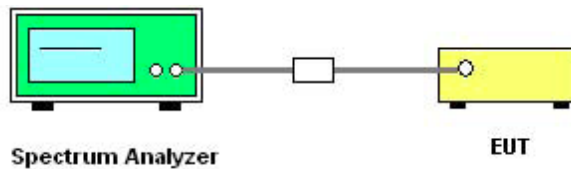

The EUT which is powered by the Battery, is coupled to the Spectrum Analyzer; the RF load attached to the EUT antenna terminal is 50Ohm; the path loss as the factor is calibrated to correct the reading. Make the measurement with the spectrum analyzer's resolution bandwidth(RBW) = 100 kHz. In order to make an accurate measurement, set the span greater than RBW.

##### 4.4 EUT OPERATION CONDITIONS

The EUT tested system was configured as the statements of 2.3 Unless otherwise a special operating condition is specified in the follows during the testing.



4.5 TEST RESULTS

|               |                         |                     |            |
|---------------|-------------------------|---------------------|------------|
| EUT :         | smart phone             | Model Name :        | Ilium L200 |
| Temperature : | 25 °C                   | Relative Humidity : | 50%        |
| Pressure :    | 1012 hPa                | Test Voltage :      | DC 3.7V    |
| Test Mode :   | GFSK(1Mbps)-00/39/78 CH |                     |            |

00 CH

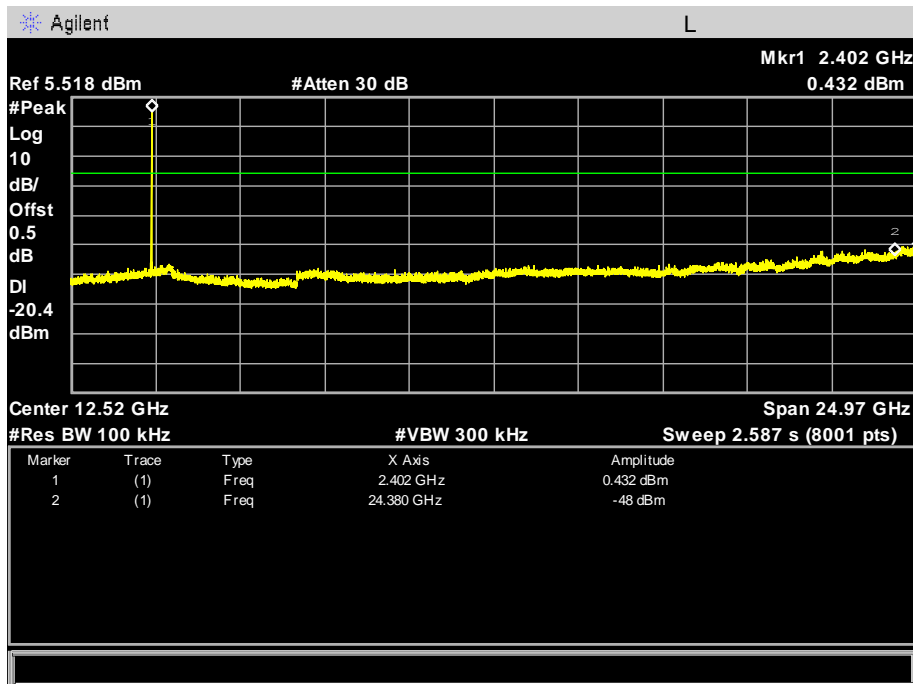

39 CH

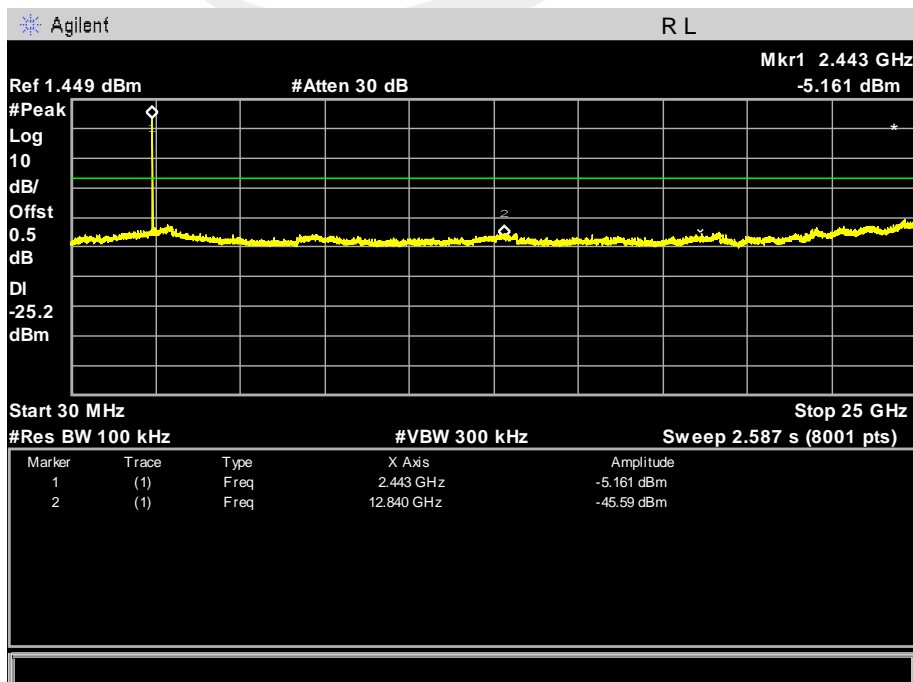



78 CH

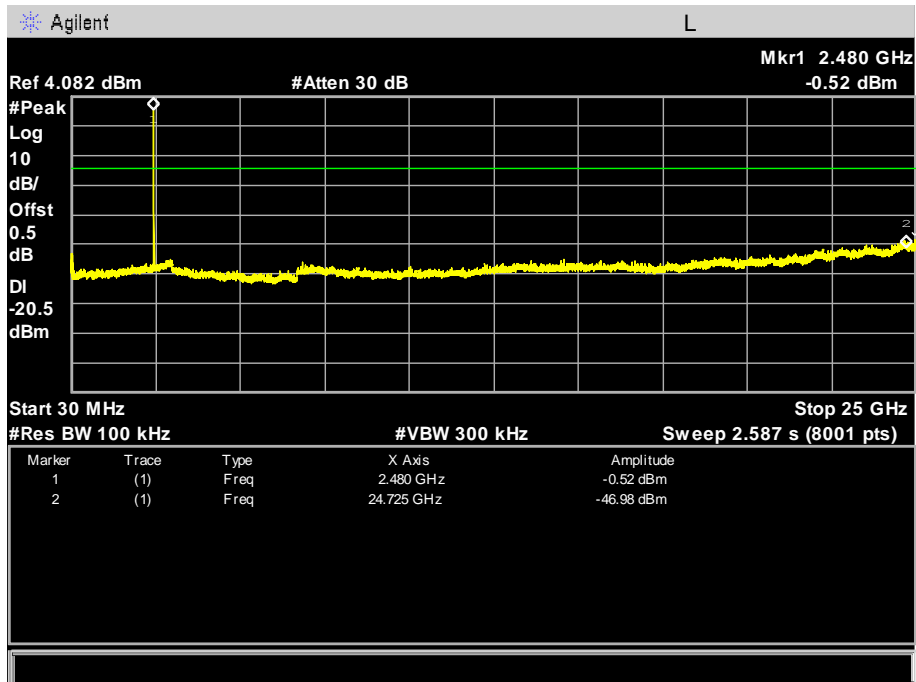



For Band edge

00 CH

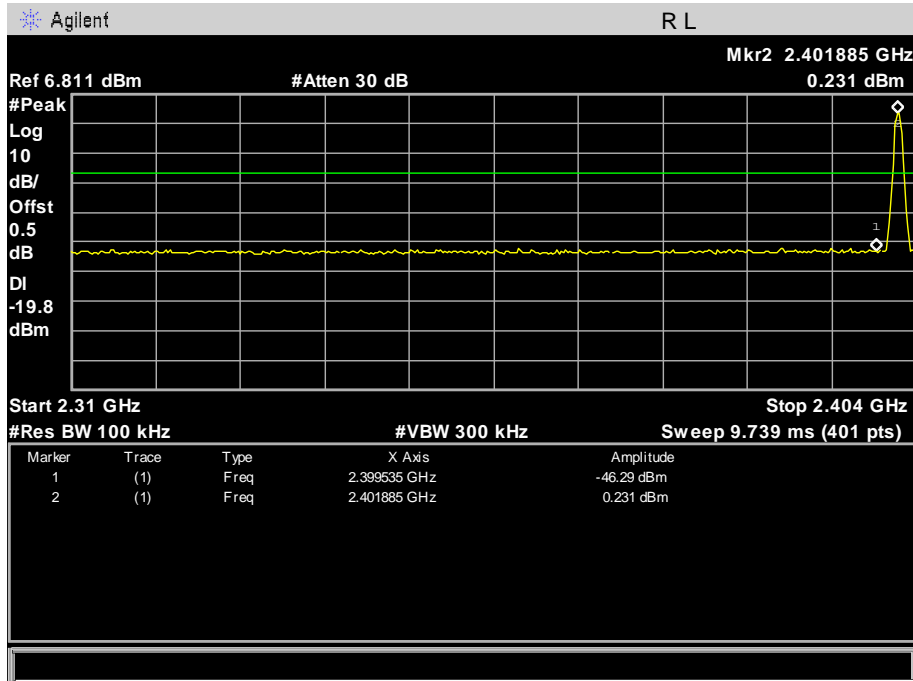

78 CH

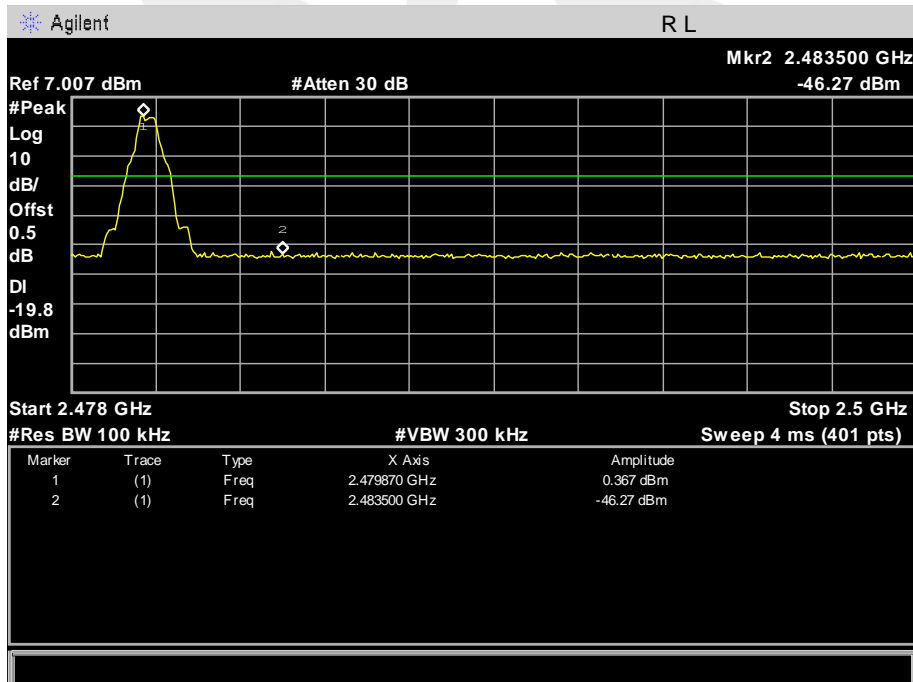



|               |                               |                     |            |
|---------------|-------------------------------|---------------------|------------|
| EUT :         | smart phone                   | Model Name :        | Ilium L200 |
| Temperature : | 25 °C                         | Relative Humidity : | 50%        |
| Pressure :    | 1012 hPa                      | Test Voltage :      | DC 3.7V    |
| Test Mode :   | π/4-DQPSK(2Mbps) –00/39/78 CH |                     |            |

00 CH

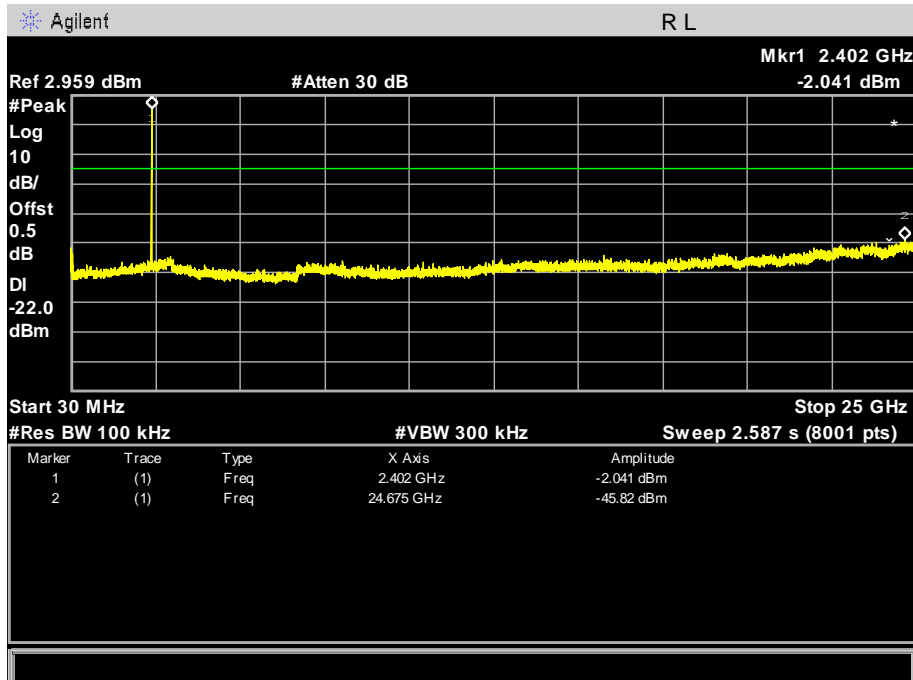

39 CH

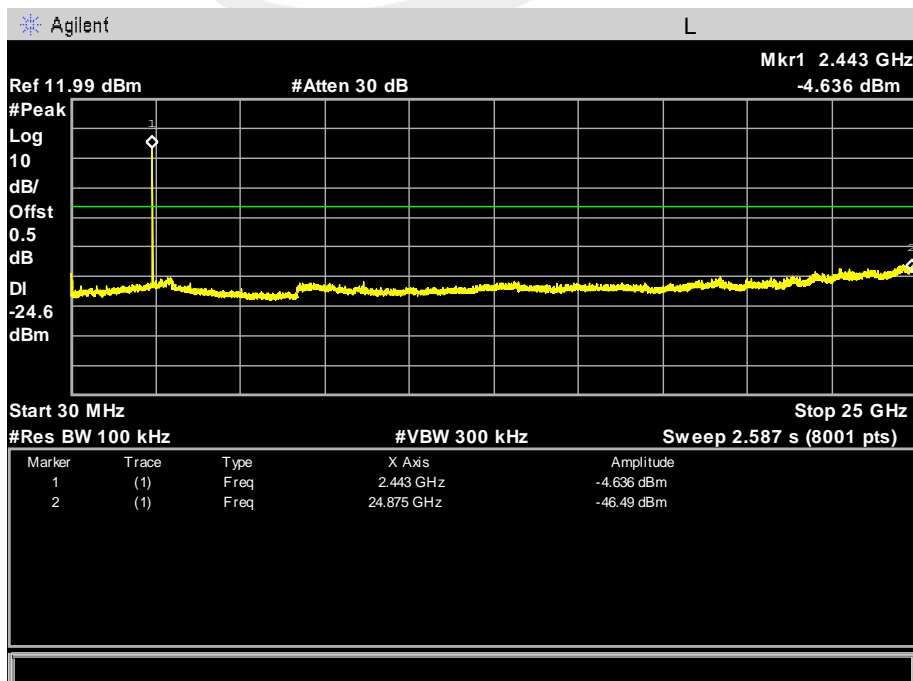





78 CH

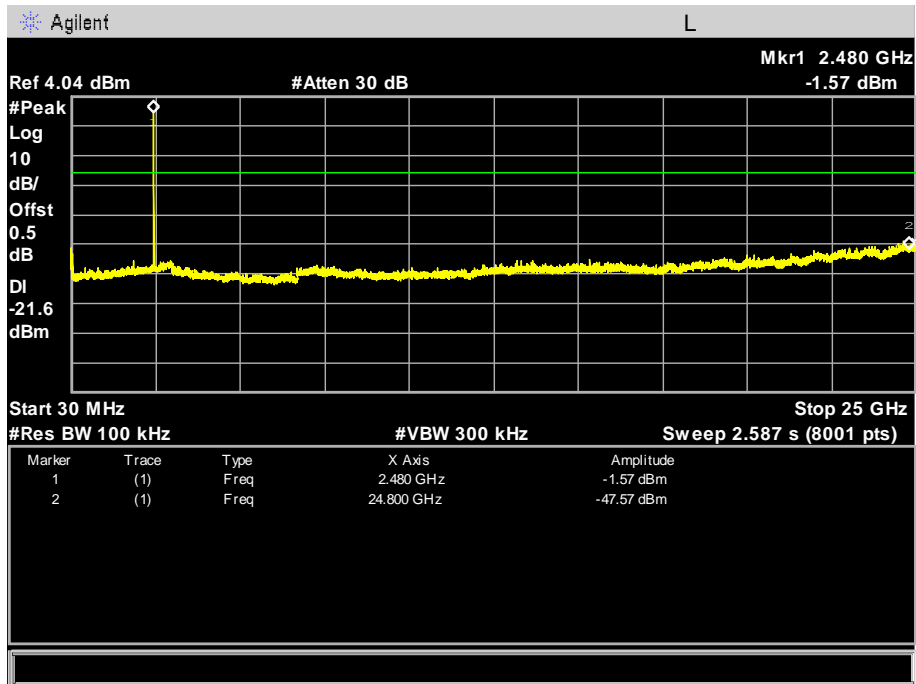



For Band edge

00 CH

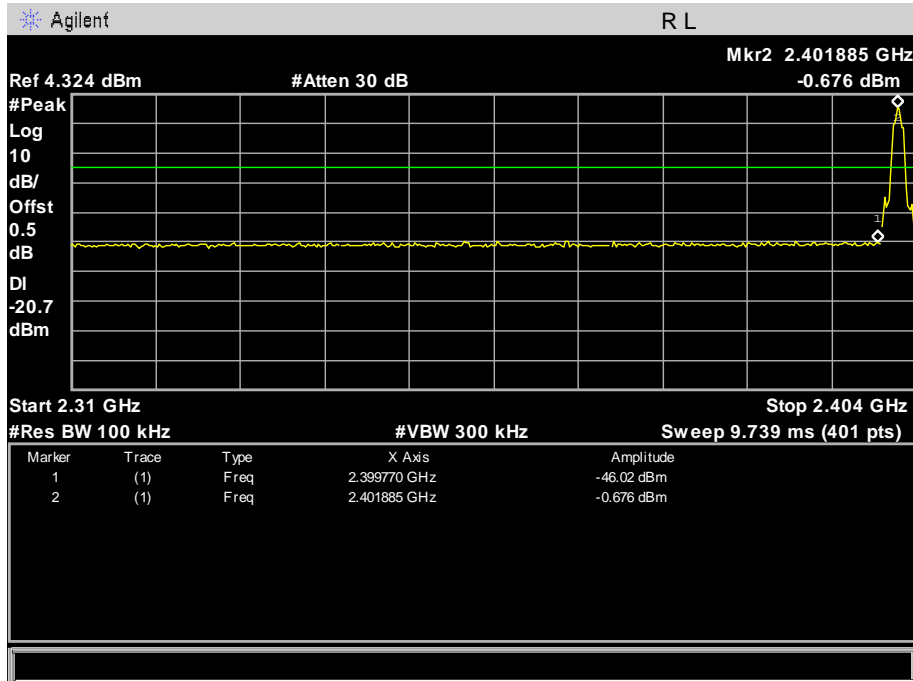

78 CH

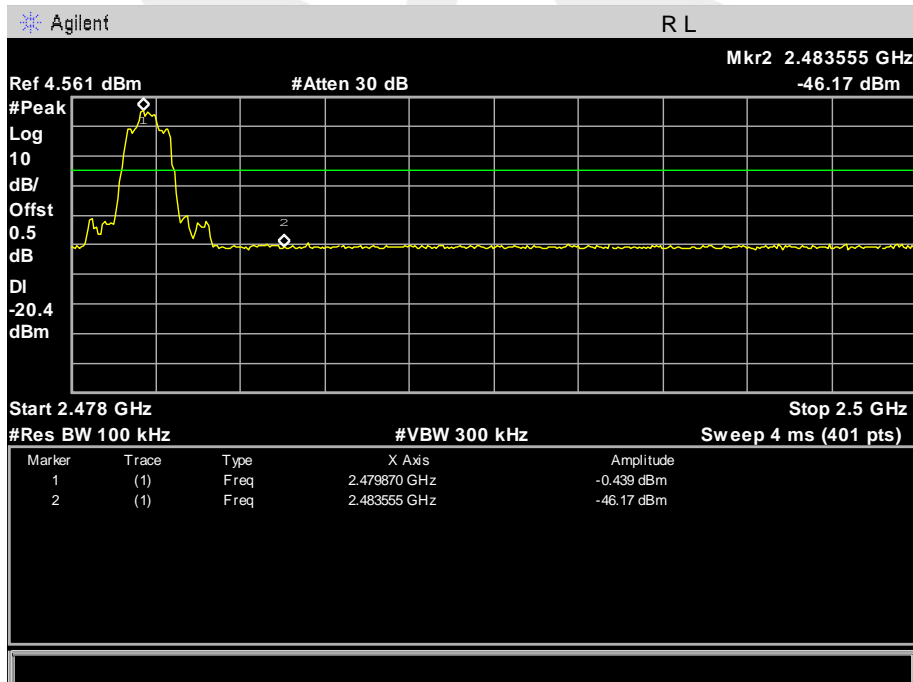



|               |                            |                     |            |
|---------------|----------------------------|---------------------|------------|
| EUT :         | smart phone                | Model Name :        | Ilium L200 |
| Temperature : | 25 °C                      | Relative Humidity : | 50%        |
| Pressure :    | 1012 hPa                   | Test Voltage :      | DC 3.7V    |
| Test Mode :   | 8-DPSK(3Mbps) -00/39/78 CH |                     |            |

00 CH

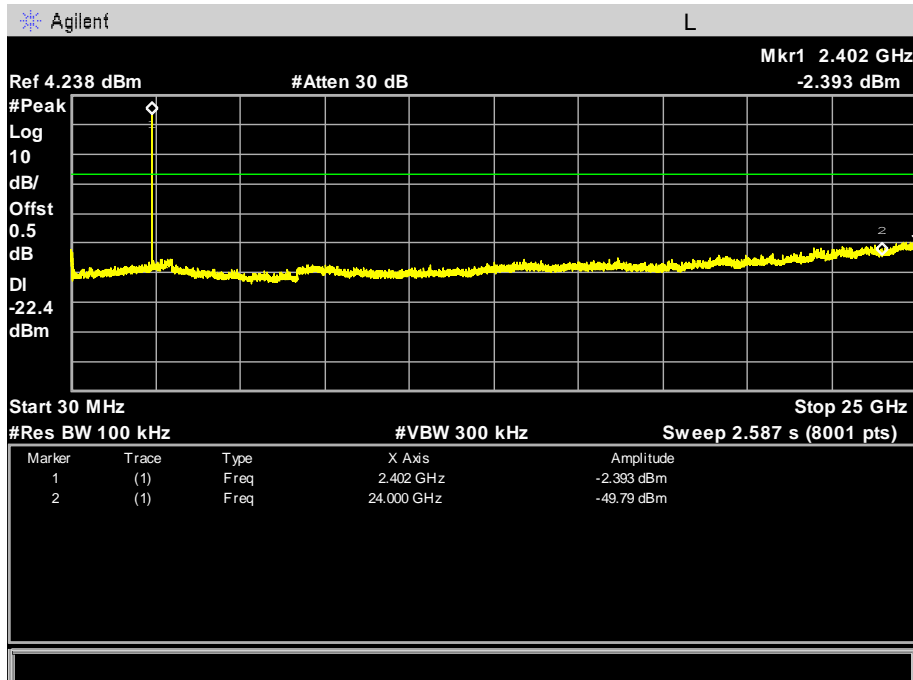

39 CH

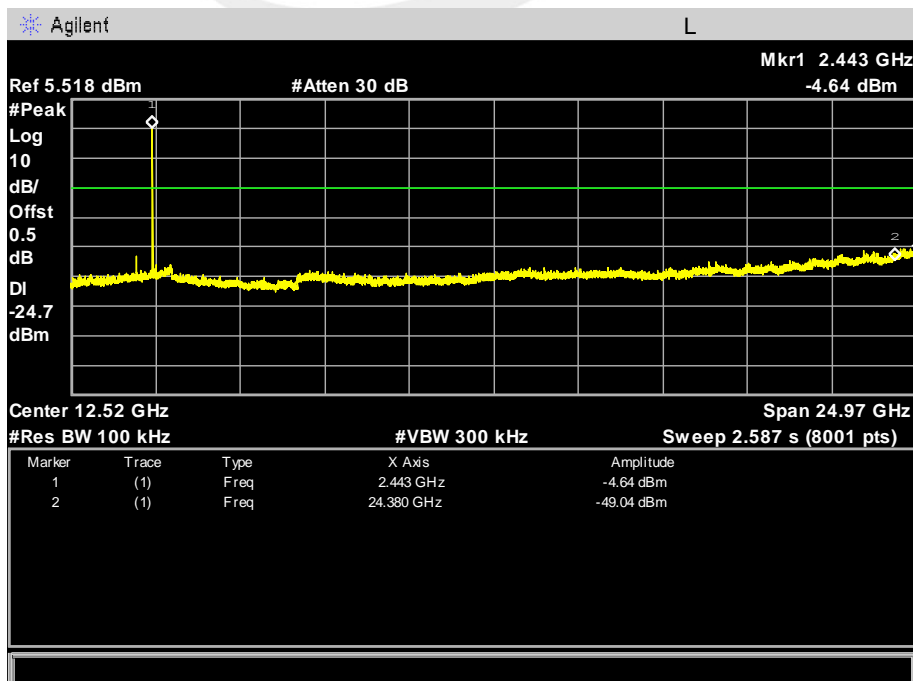



78 CH

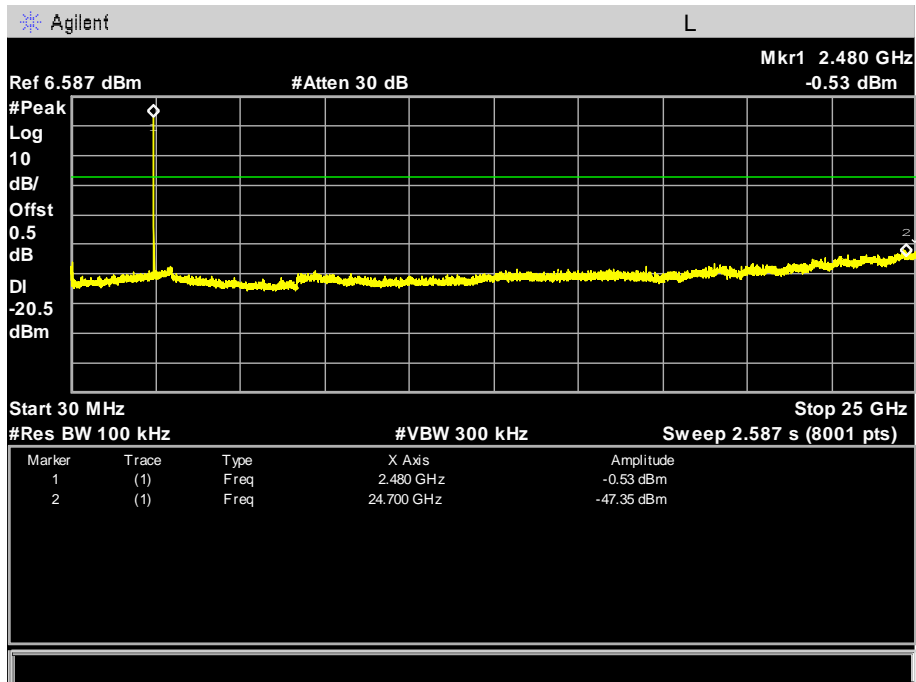



For Band edge

00 CH

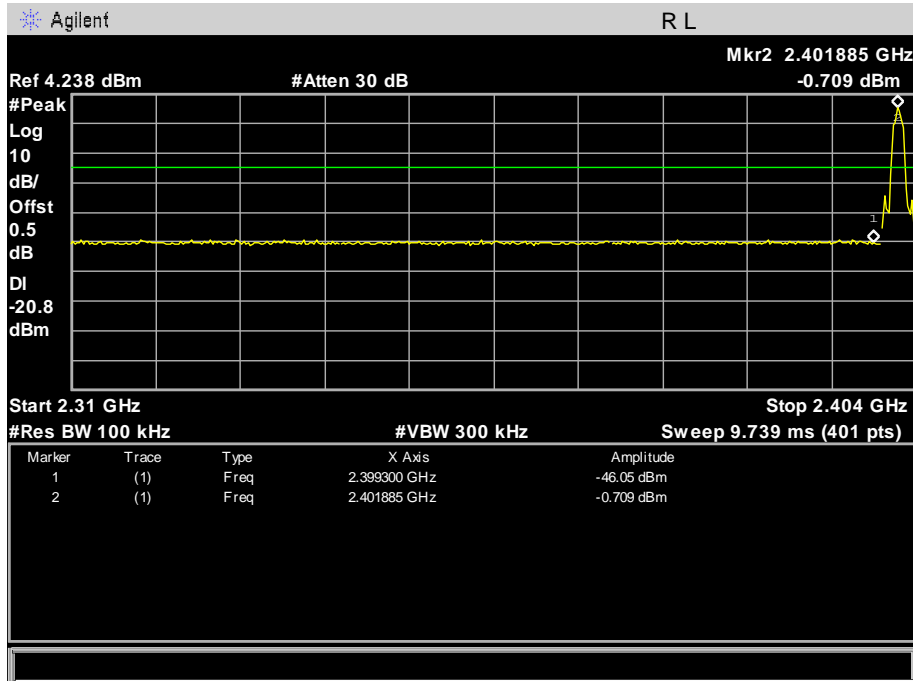

78 CH

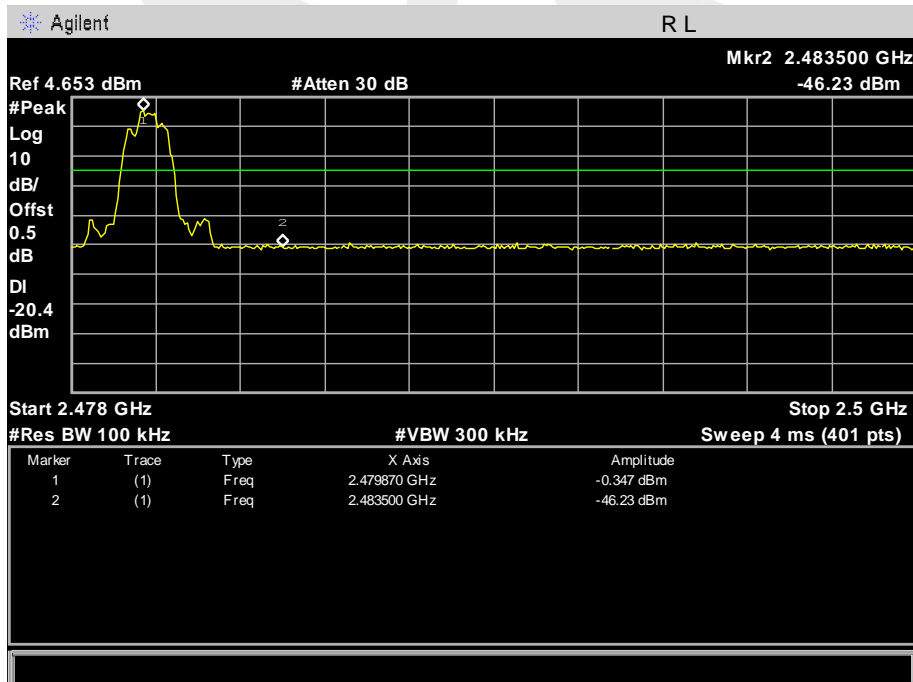



## 5. NUMBER OF HOPPING CHANNEL

### 5.1 APPLIED PROCEDURES / LIMIT

| FCC Part15 (15.247) , Subpart C |                           |       |                       |        |
|---------------------------------|---------------------------|-------|-----------------------|--------|
| Section                         | Test Item                 | Limit | Frequency Range (MHz) | Result |
| 15.247 (a)(1)(iii)              | Number of Hopping Channel | ≥15   | 2400-2483.5           | PASS   |

| Spectrum Parameters | Setting                     |
|---------------------|-----------------------------|
| Attenuation         | Auto                        |
| Span Frequency      | > Operating Frequency Range |
| RB                  | 100 KHz                     |
| VB                  | 100 KHz                     |
| Detector            | Peak                        |
| Trace               | Max Hold                    |
| Sweep Time          | Auto                        |

### 5.2 TEST PROCEDURE

- The EUT was directly connected to the spectrum analyzer and antenna output port as show in the block diagram below,
- Spectrum Setting : RBW= 100K, VBW=100K, Sweep time = Auto.

### 5.3 TEST SETUP



### 5.4 EUT OPERATION CONDITIONS

The EUT tested system was configured as the statements of 2.4 Unless otherwise a special operating condition is specified in the follows during the testing.



### 5.5 TEST RESULTS

|               |              |                     |            |
|---------------|--------------|---------------------|------------|
| EUT :         | smart phone  | Model Name :        | Ilium L200 |
| Temperature : | 25 °C        | Relative Humidity : | 60%        |
| Pressure :    | 1015 hPa     | Test Voltage :      | DC 3.7V    |
| Test Mode :   | Hopping Mode |                     |            |

Number of Hopping Channel

79

#### Hopping channel

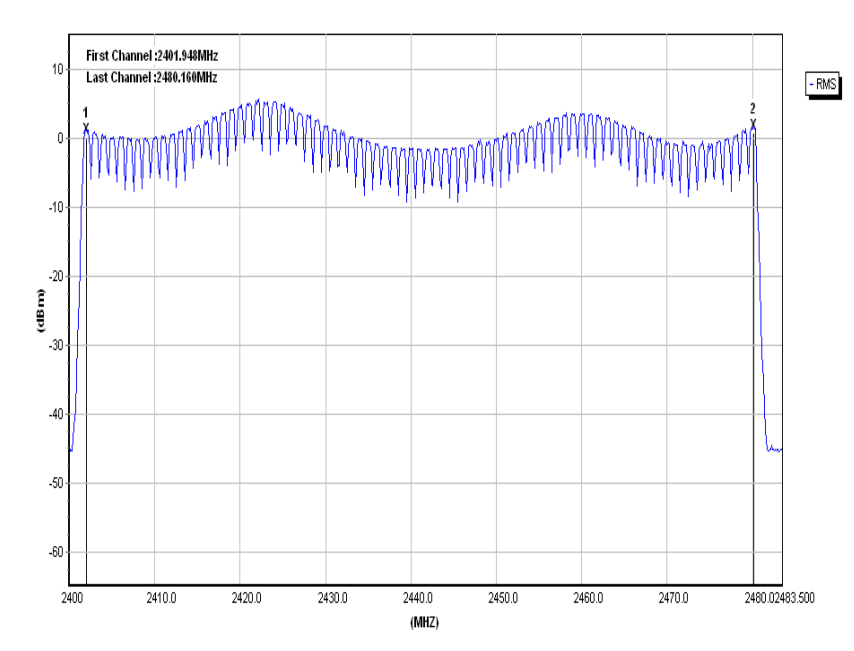



## 6. AVERAGE TIME OF OCCUPANCY

### 6.1 APPLIED PROCEDURES / LIMIT

| FCC Part15 (15.247) , Subpart C |                           |        |                       |        |
|---------------------------------|---------------------------|--------|-----------------------|--------|
| Section                         | Test Item                 | Limit  | Frequency Range (MHz) | Result |
| 15.247 (a)(1)(iii)              | Average Time of Occupancy | 0.4sec | 2400-2483.5           | PASS   |

### 6.2 TEST PROCEDURE

- a. The transmitter output (antenna port) was connected to the spectrum analyzer
- b. Set RBW of spectrum analyzer to 1MHz and VBW to 3MHz.
- c. Use a video trigger with the trigger level set to enable triggering only on full pulses.
- d. Sweep Time is more than once pulse time.  
Set the center frequency on any frequency would be measure and set the frequency span to
- e. zero span.
- f. Measure the maximum time duration of one single pulse.
- g. Set the EUT for DH5, DH3 and DH1 packet transmitting.
- h. Measure the maximum time duration of one single pulse.
- i. DH5 Packet permit maximum  $1600 / 79 / 6 = 3.37$  hops per second in each channel (5 time slots RX, 1 time slot TX). So, the dwell time is the time duration of the pulse times  $3.37 \times 31.6 = 106.6$  within 31.6 seconds.
- j. DH3 Packet permit maximum  $1600 / 79 / 4 = 5.06$  hops per second in each channel (3 time slots RX, 1 time slot TX). So, the dwell time is the time duration of the pulse times  $5.06 \times 31.6 = 160$  within 31.6 seconds.
- k. DH1 Packet permit maximum  $1600 / 79 / 2 = 10.12$  hops per second in each channel (1 time slot RX, 1 time slot TX). So, the dwell time is the time duration of the pulse times  $10.12 \times 31.6 = 320$  within 31.6 seconds.

### 6.3 TEST SETUP



### 6.4 EUT OPERATION CONDITIONS

The EUT tested system was configured as the statements of 2.4 Unless otherwise a special operating condition is specified in the follows during the testing.





## 6.5 TEST RESULTS

|               |                         |                     |            |
|---------------|-------------------------|---------------------|------------|
| EUT :         | smart phone             | Model Name :        | Ilium L200 |
| Temperature : | 25 °C                   | Relative Humidity : | 50%        |
| Pressure :    | 1012 hPa                | Test Voltage :      | DC 3.7V    |
| Test Mode :   | GFSK(1Mbps)-DH1/DH3/DH5 |                     |            |

| Data Packet | Frequency | Pulse Duration (ms) | Dwell Time (s) | Limits(s) |
|-------------|-----------|---------------------|----------------|-----------|
| DH1         | 2441 MHz  | 0.370               | 0.118          | 0.4       |
| DH3         | 2441 MHz  | 1.630               | 0.261          | 0.4       |
| DH5         | 2441 MHz  | 2.880               | 0.307          | 0.4       |

CH39-DH1

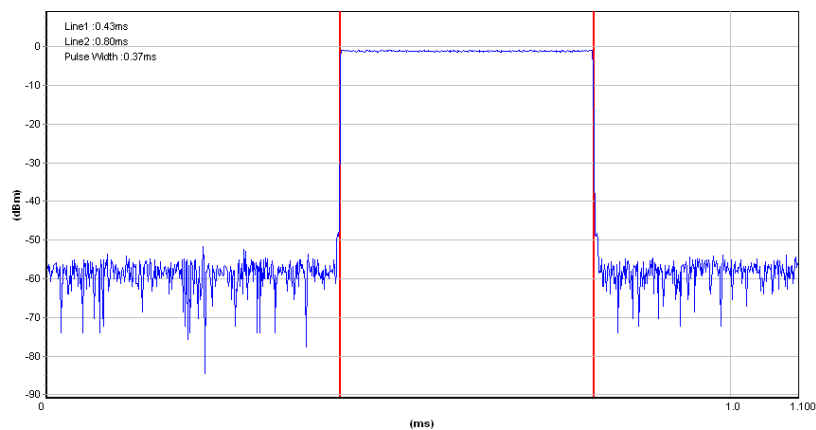



### CH39-DH3

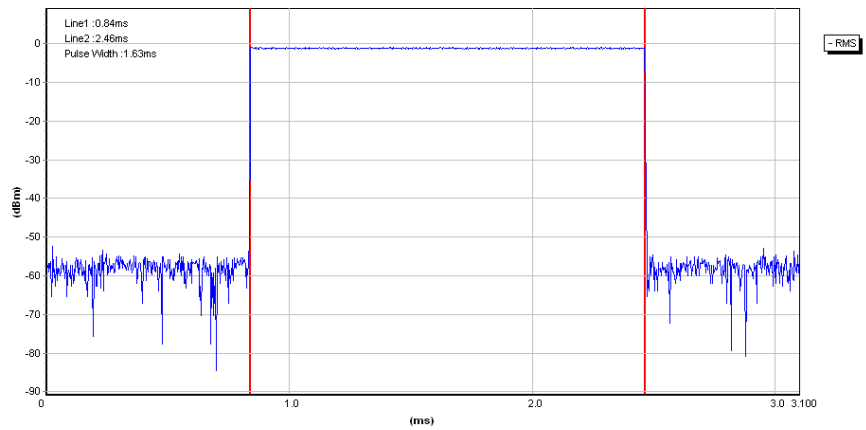

### CH39-DH5

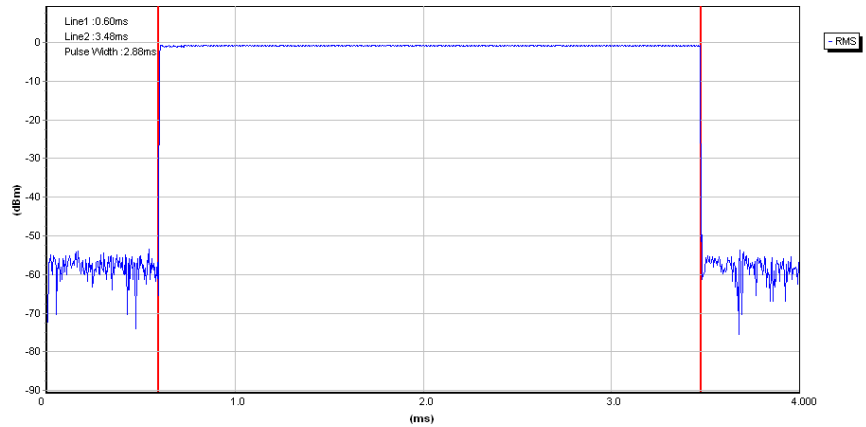



|               |                                  |                     |            |
|---------------|----------------------------------|---------------------|------------|
| EUT :         | smart phone                      | Model Name :        | Ilium L200 |
| Temperature : | 25 °C                            | Relative Humidity : | 50%        |
| Pressure :    | 1012 hPa                         | Test Voltage :      | DC 3.7V    |
| Test Mode :   | π/4-DQPSK(2Mbps) –2DH1/2DH3/2DH5 |                     |            |

| Data Packet | Frequency | Pulse Duration (ms) | Dwell Time (s) | Limits(s) |
|-------------|-----------|---------------------|----------------|-----------|
| DH1         | 2441 MHz  | 0.380               | 0.122          | 0.4       |
| DH3         | 2441 MHz  | 1.630               | 0.261          | 0.4       |
| DH5         | 2441 MHz  | 2.880               | 0.307          | 0.4       |

CH39-2DH1

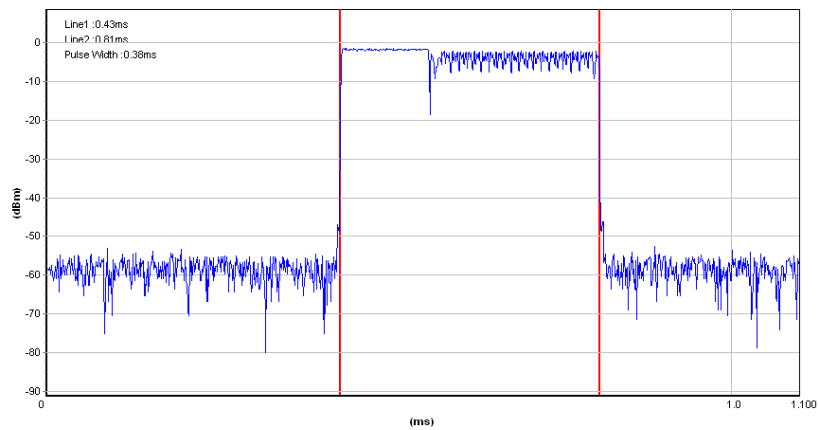



### CH39-2DH3

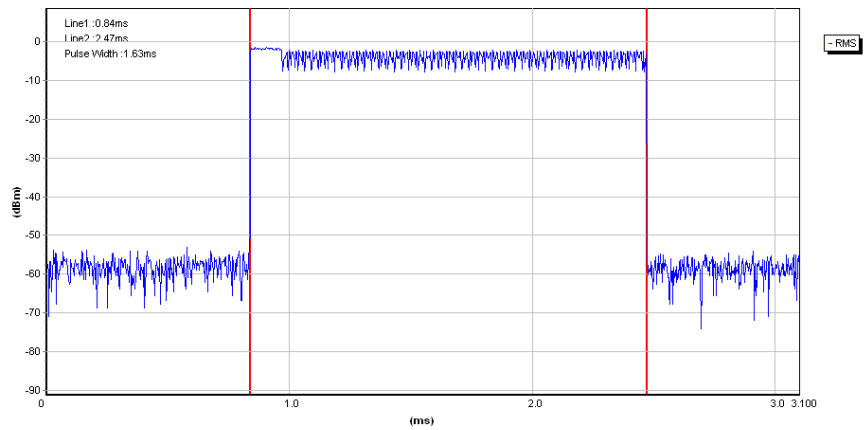

### CH39-2DH5

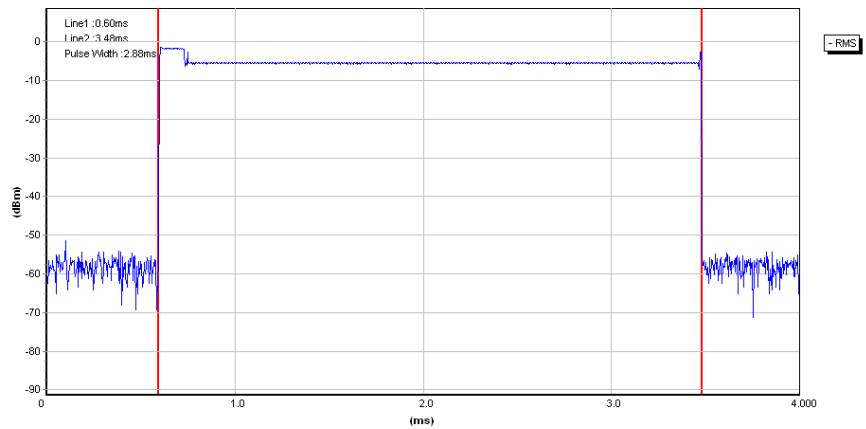



|               |                              |                     |            |
|---------------|------------------------------|---------------------|------------|
| EUT :         | smart phone                  | Model Name :        | Ilium L200 |
| Temperature : | 25 °C                        | Relative Humidity : | 50%        |
| Pressure :    | 1012 hPa                     | Test Voltage :      | DC 3.7V    |
| Test Mode :   | 8DPSK(3Mbps) –3DH1/3DH3/3DH5 |                     |            |

| Data Packet | Frequency | Pulse Duration (ms) | Dwell Time (s) | Limits(s) |
|-------------|-----------|---------------------|----------------|-----------|
| DH1         | 2441 MHz  | 0.380               | 0.122          | 0.4       |
| DH3         | 2441 MHz  | 1.640               | 0.262          | 0.4       |
| DH5         | 2441 MHz  | 2.880               | 0.307          | 0.4       |

## CH39-3DH1

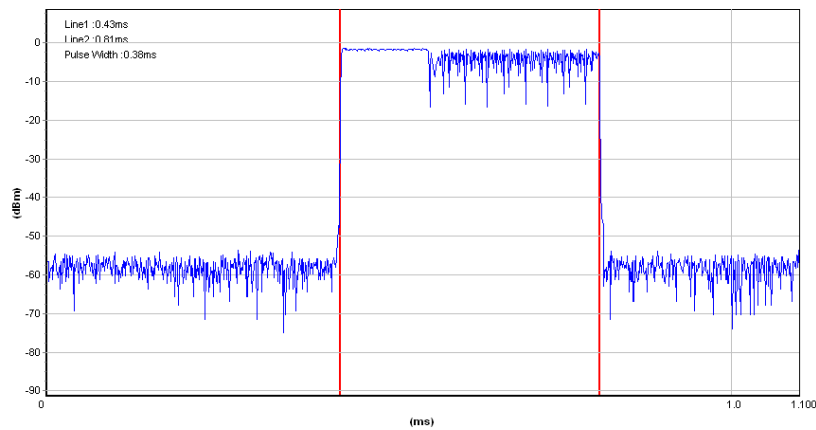



### CH39-3DH3

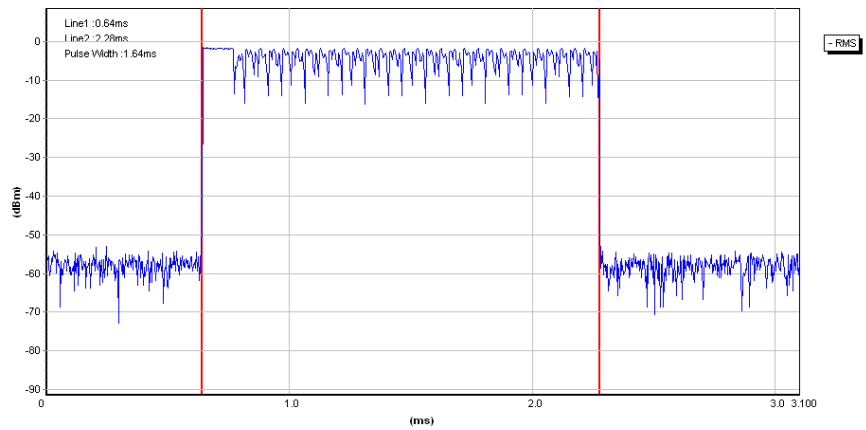

### CH39-3DH5

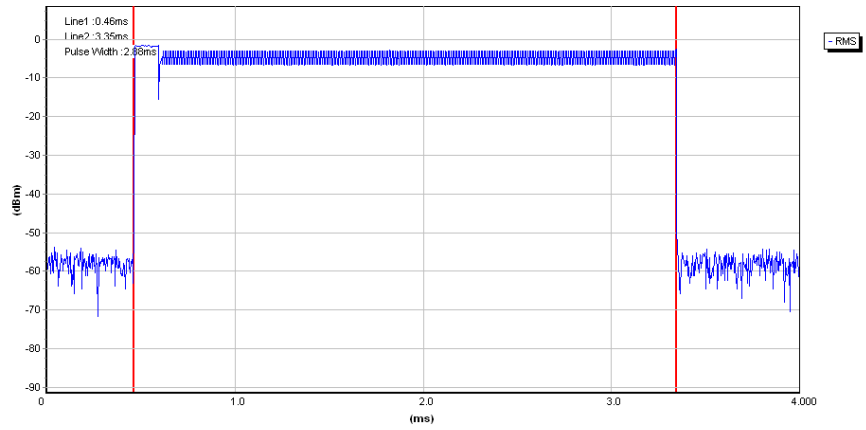

## 7. HOPPING CHANNEL SEPARATION MEASUREMENT

### 7.1 APPLIED PROCEDURES / LIMIT

Frequency hopping systems operating in the 2400-2483.5 MHz band may have hopping channel carrier frequencies that are separated by 20 dB bandwidth of the hopping channel, whichever is greater.

| Spectrum Parameter | Setting   |
|--------------------|---|
| Attenuation        | Auto  |
| Span Frequency     | > Measurement Bandwidth or Channel Separation           |
| RB                 | 30 kHz (20dB Bandwidth) / 30 kHz (Channel Separation)   |
| VB                 | 100 kHz (20dB Bandwidth) / 100 kHz (Channel Separation) |
| Detector           | Peak  |
| Trace              | Max Hold  |
| Sweep Time         | Auto  |

### 7.2 TEST PROCEDURE

- The transmitter output (antenna port) was connected to the spectrum analyser in peak hold mode.
- The resolution bandwidth of 30 kHz and the video bandwidth of 100 kHz were utilised for 20 dB bandwidth measurement.
- The resolution bandwidth of 30 kHz and the video bandwidth of 100 kHz were utilised for channel separation measurement.

### 7.3 TEST SETUP

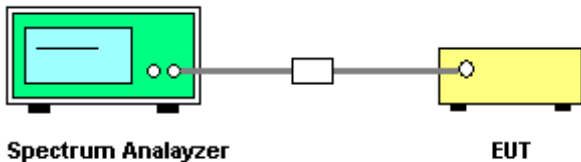

### 7.4 EUT OPERATION CONDITIONS

The EUT was programmed to be in continuously transmitting mode.



7.5 TEST RESULTS

|               |                                      |                     |            |
|---------------|--------------------------------------|---------------------|------------|
| EUT :         | smart phone                          | Model Name :        | Ilium L200 |
| Temperature : | 25 °C                                | Relative Humidity : | 50%        |
| Pressure :    | 1012 hPa                             | Test Voltage :      | DC 3.7V    |
| Test Mode :   | CH00 / CH39 /CH78 (GFSK(1Mbps) Mode) |                     |            |

| Frequency | Ch. Separation (MHz) | Limit | Result   |
|-----------|----------------------|-------|----------|
| 2402 MHz  | ≥1.000               | 0.848 | Complies |
| 2441 MHz  | ≥1.000               | 0.889 | Complies |
| 2480 MHz  | ≥1.000               | 0.868 | Complies |

For GFSK: Ch. Separation Limits: >20dB bandwidth

CH00 -1Mbps

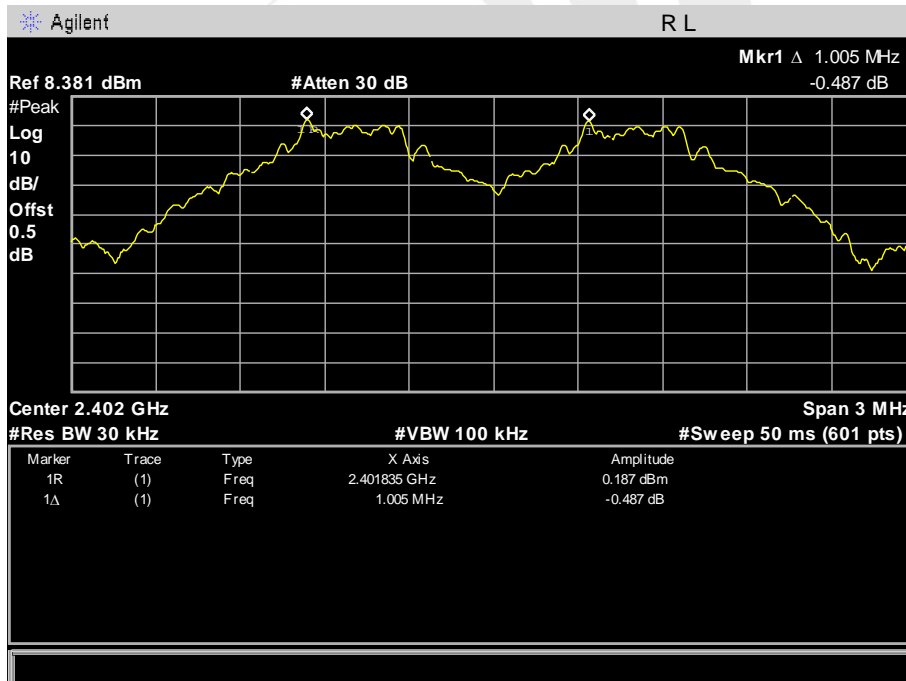





### CH39 -1Mbps

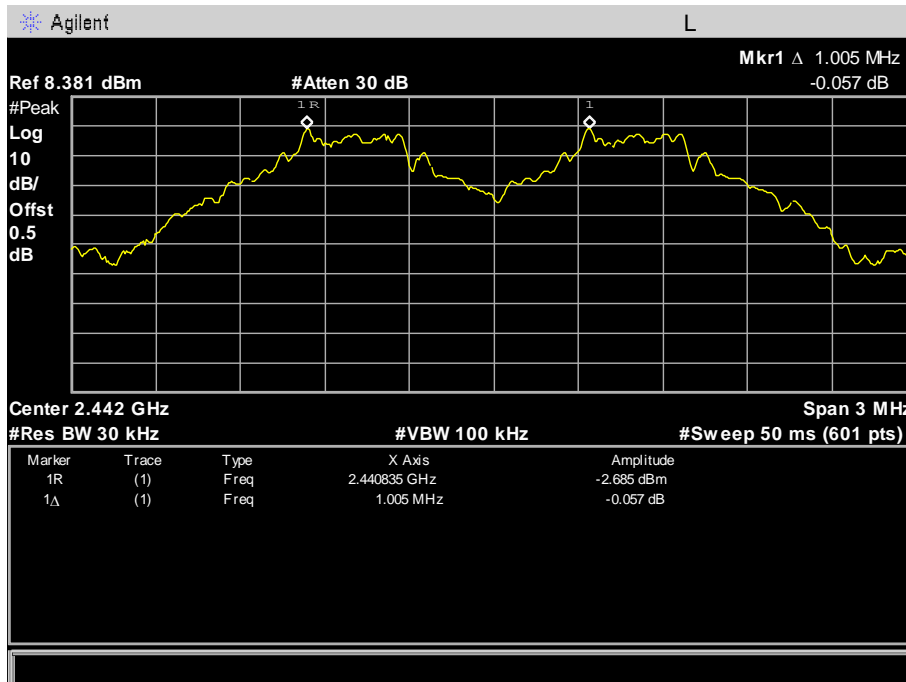

### CH78 -1Mbps

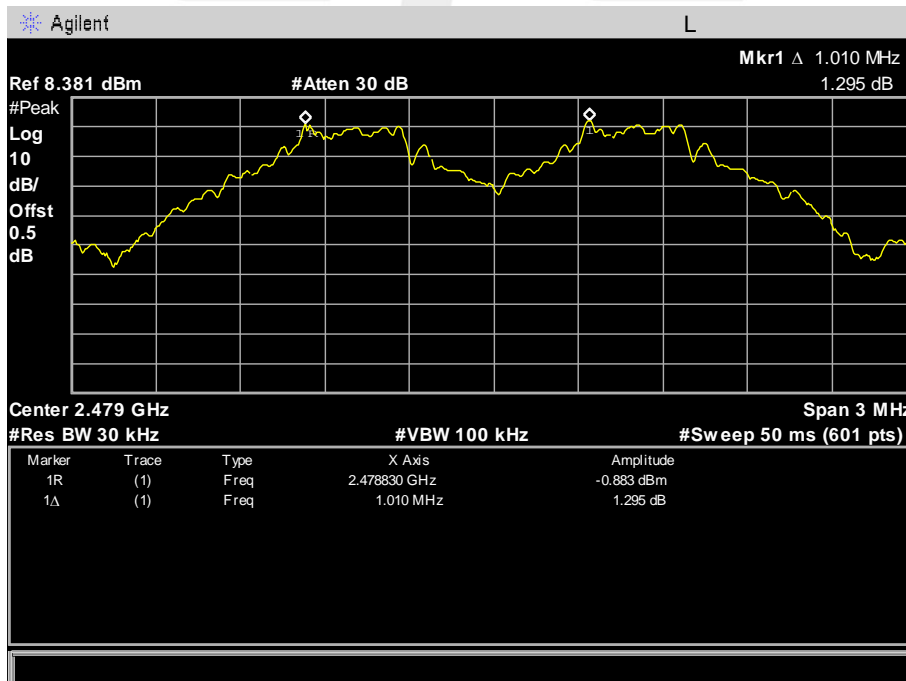



|               |   |                     |            |
|---------------|---|---------------------|------------|
| EUT :         | smart phone                                     | Model Name :        | Ilium L200 |
| Temperature : | 25 °C   | Relative Humidity : | 50%        |
| Pressure :    | 1012 hPa  | Test Voltage :      | DC 3.7V    |
| Test Mode :   | CH00 / CH39 /CH78 ( $\pi/4$ -DQPSK(2Mbps) Mode) |                     |            |

| Frequency | Ch. Separation (MHz) | Limit | Result   |
|-----------|----------------------|-------|----------|
| 2402 MHz  | $\geq 1.000$         | 0.868 | Complies |
| 2441 MHz  | $\geq 1.000$         | 0.868 | Complies |
| 2480 MHz  | $\geq 1.000$         | 0.861 | Complies |

For  $\pi/4$ -DQPSK(2Mbps): Ch. Separation Limits: > two-thirds 20dB bandwidth

**CH00 -2Mbps**

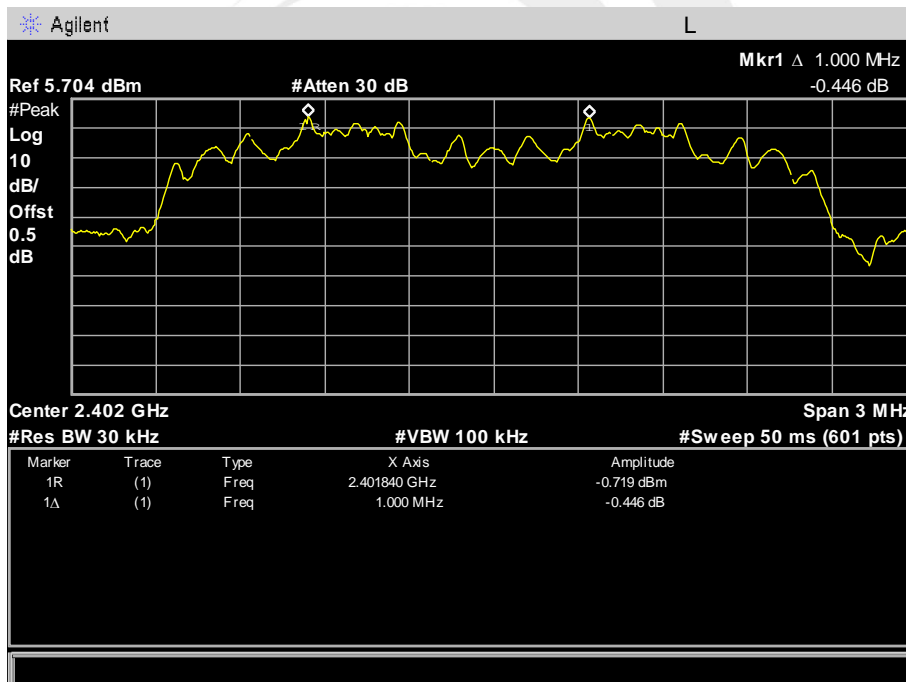



### CH39 -2Mbps

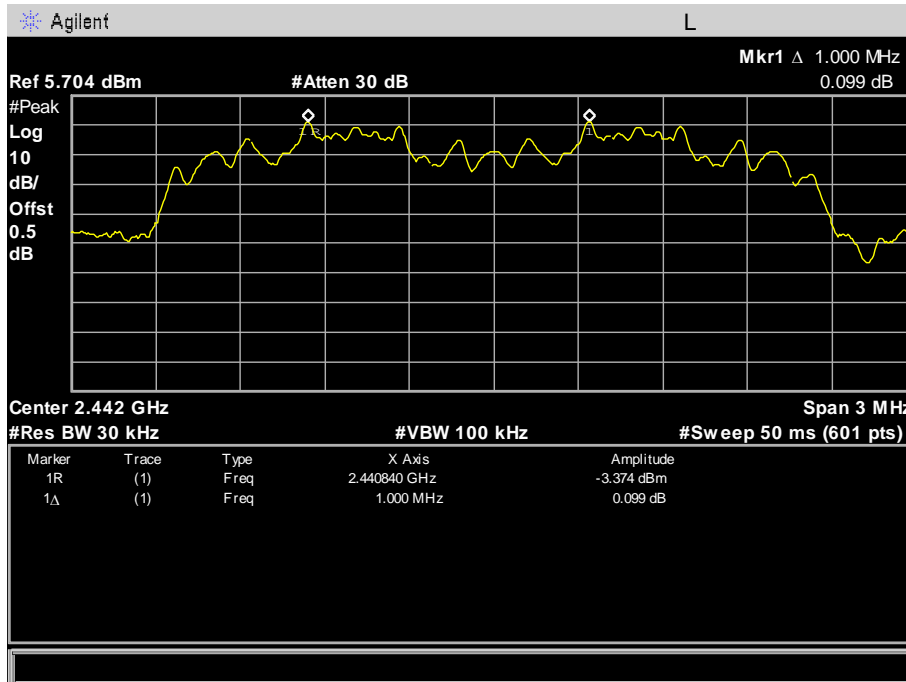

### CH78 -2Mbps

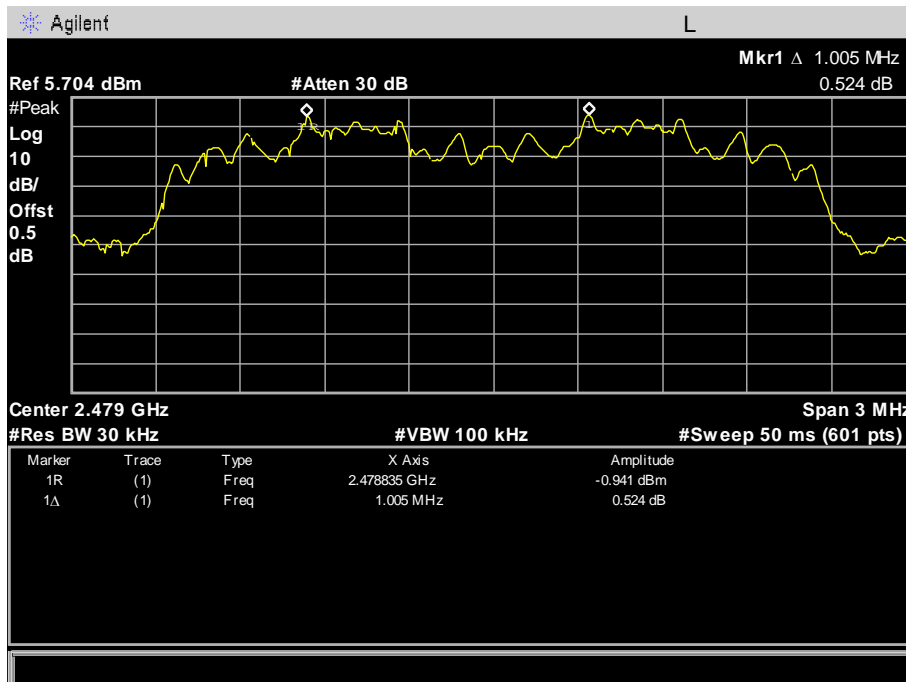



|               |                                       |                     |            |
|---------------|---------------------------------------|---------------------|------------|
| EUT :         | smart phone                           | Model Name :        | Ilium L200 |
| Temperature : | 25 °C                                 | Relative Humidity : | 50%        |
| Pressure :    | 1012 hPa                              | Test Voltage :      | DC 3.7V    |
| Test Mode :   | CH00 / CH39 /CH78 (8-DPSK(3Mbps)Mode) |                     |            |

| Frequency | Ch. Separation (MHz) | Limit | Result   |
|-----------|----------------------|-------|----------|
| 2402 MHz  | ≥1.000               | 0.827 | Complies |
| 2441 MHz  | ≥1.000               | 0.846 | Complies |
| 2480 MHz  | ≥1.000               | 0.851 | Complies |

For 8-DPSK(3Mbps):

**Ch. Separation Limits: > two-thirds 20dB bandwidth**

**CH00 -3Mbps**

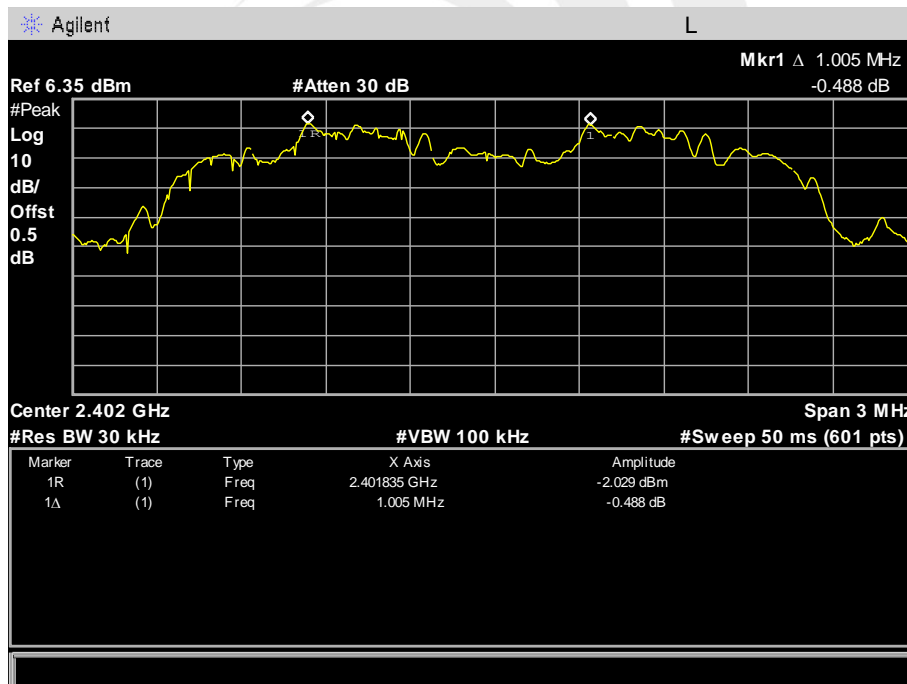



### CH39 -3Mbps

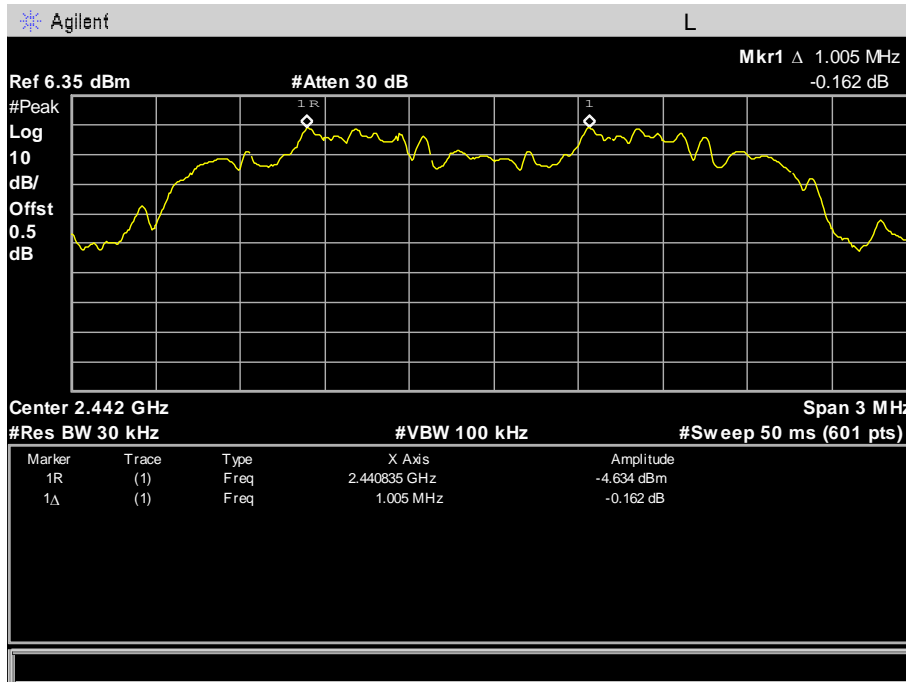

### CH78 -3Mbps

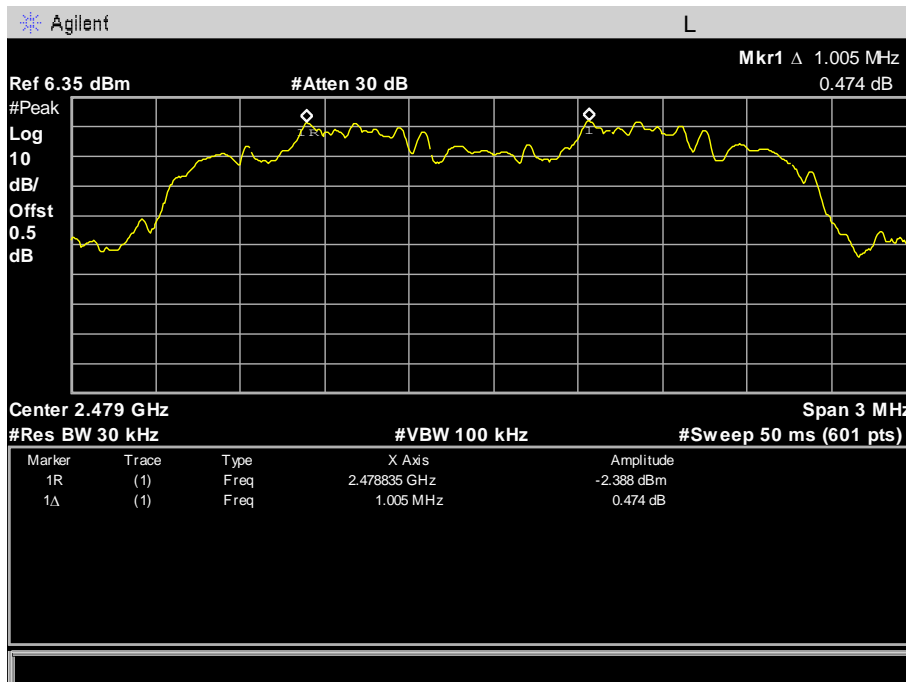



## 8. BANDWIDTH TEST

### 8.1 APPLIED PROCEDURES / LIMIT

#### FCC Part15 (15.247) , Subpart C

| Section          | Test Item | Limit            | Frequency Range (MHz) | Result |
|------------------|-----------|------------------|-----------------------|--------|
| 15.247<br>(a)(1) | Bandwidth | (20dB bandwidth) | 2400-2483.5           | PASS   |

| Spectrum Parameter | Setting   |
|--------------------|---|
| Attenuation        | Auto  |
| Span Frequency     | > Measurement Bandwidth or Channel Separation           |
| RB                 | 30 kHz (20dB Bandwidth) / 30 kHz (Channel Separation)   |
| VB                 | 100 kHz (20dB Bandwidth) / 100 kHz (Channel Separation) |
| Detector           | Peak  |
| Trace              | Max Hold  |
| Sweep Time         | Auto  |

### 8.2 TEST PROCEDURE

- The EUT was directly connected to the spectrum analyzer and antenna output port as show in the block diagram below,
- Spectrum Setting : RBW= 30KHz, VBW=100KHz, Sweep time = Auto.

### 8.3 TEST SETUP

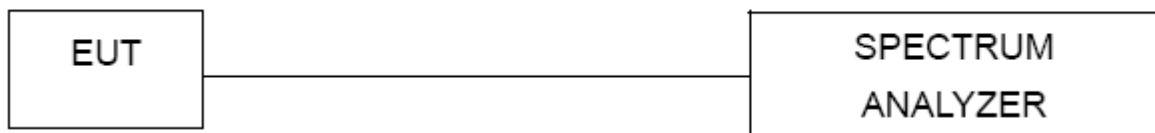

### 8.4 EUT OPERATION CONDITIONS

The EUT tested system was configured as the statements of 2.4 Unless otherwise a special operating condition is specified in the follows during the testing.



8.5 TEST RESULTS

|               |                             |                     |            |
|---------------|-----------------------------|---------------------|------------|
| EUT :         | smart phone                 | Model Name :        | Ilium L200 |
| Temperature : | 25 °C                       | Relative Humidity : | 50%        |
| Pressure :    | 1012 hPa                    | Test Voltage :      | DC 3.7V    |
| Test Mode :   | GFSK(1Mbps)CH00 / CH39 /C78 |                     |            |

| Frequency | 20dB Bandwidth (MHz) | Result |
|-----------|----------------------|--------|
| 2402 MHz  | 0.848                | PASS   |
| 2441 MHz  | 0.889                | PASS   |
| 2480 MHz  | 0.868                | PASS   |

CH00 -1Mbps

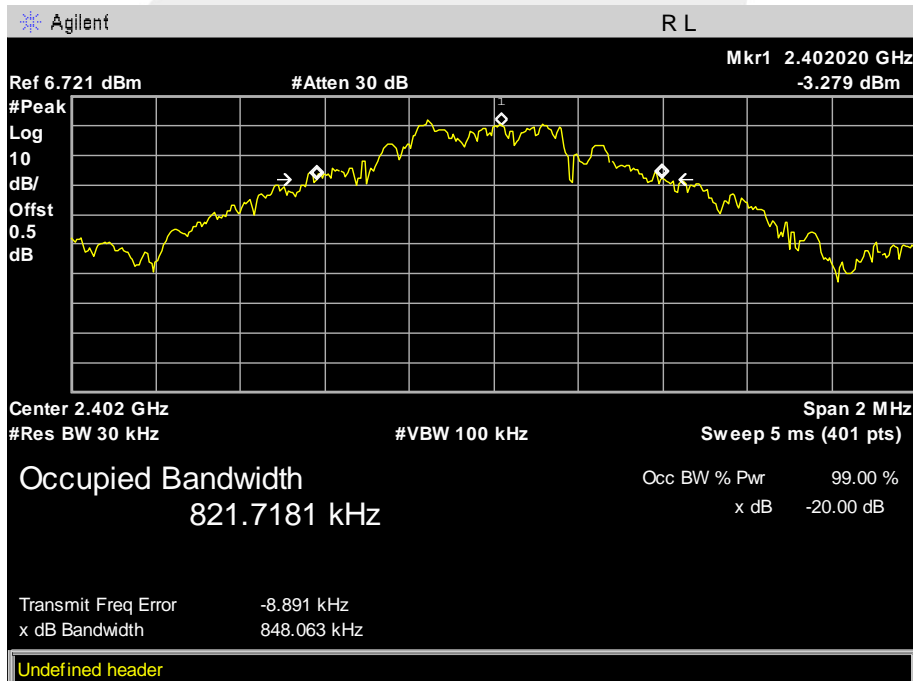



### CH39 -1Mbps

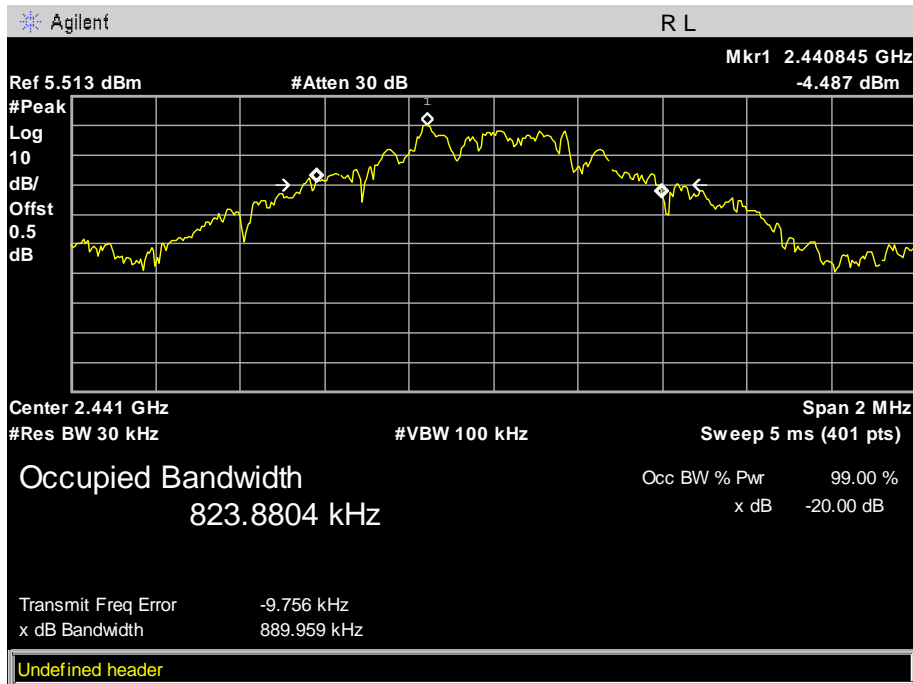

### CH78 -1Mbps

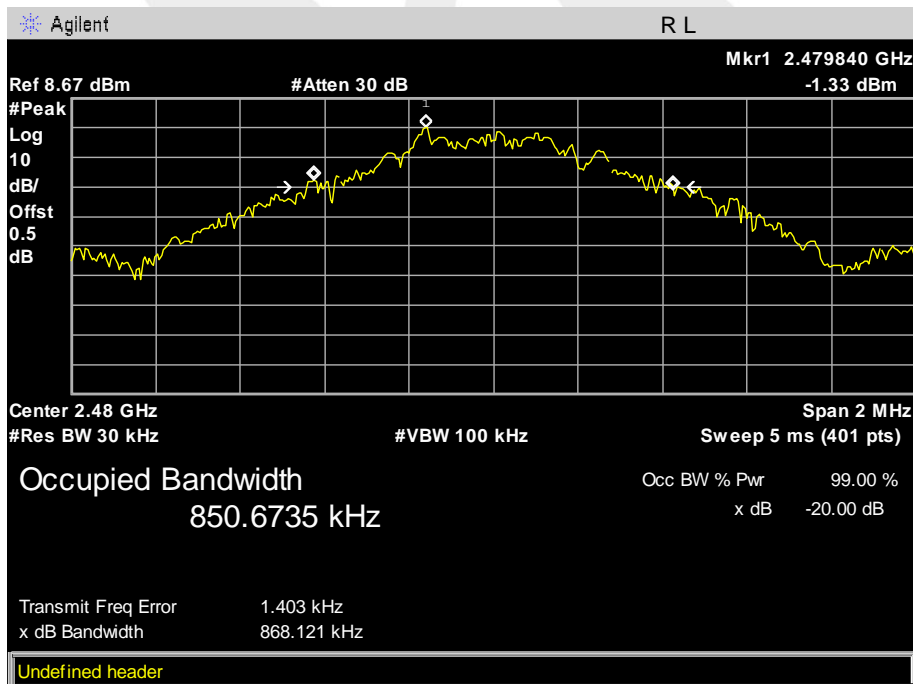





|               |                                  |                     |            |
|---------------|----------------------------------|---------------------|------------|
| EUT :         | smart phone                      | Model Name :        | Ilium L200 |
| Temperature : | 25 °C                            | Relative Humidity : | 50%        |
| Pressure :    | 1012 hPa                         | Test Voltage :      | DC 3.7V    |
| Test Mode :   | π/4-DQPSK(2Mbps)CH00 / CH39 /C78 |                     |            |

| Frequency | 20dB Bandwidth(MHz) | Result |
|-----------|---------------------|--------|
| 2402 MHz  | 1.303               | PASS   |
| 2441 MHz  | 1.303               | PASS   |
| 2480 MHz  | 1.292               | PASS   |

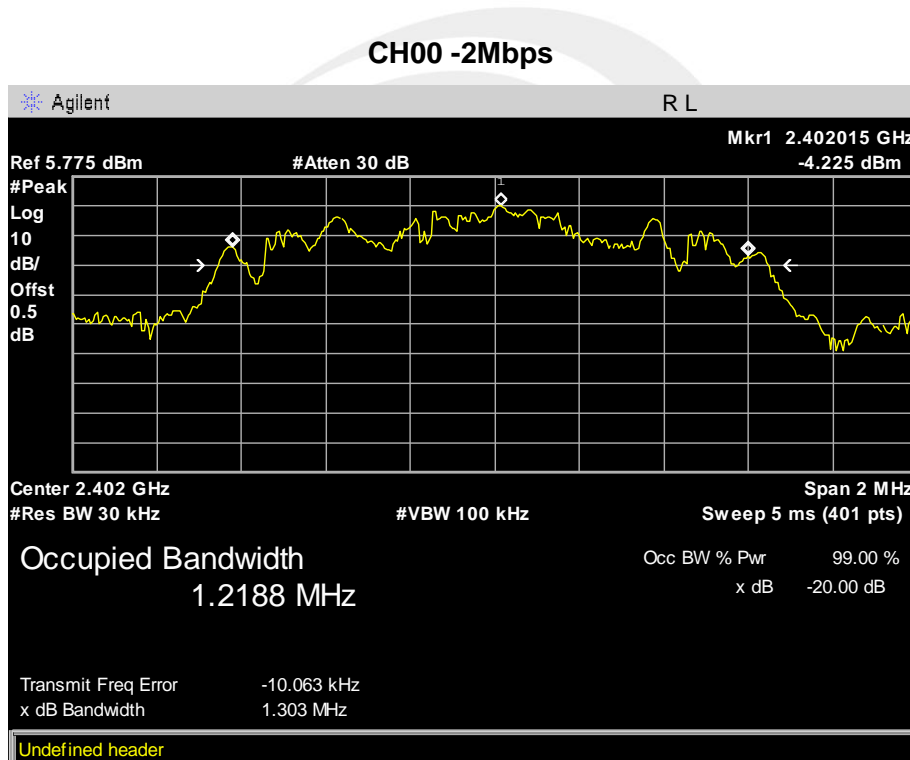



### CH39 -2Mbps

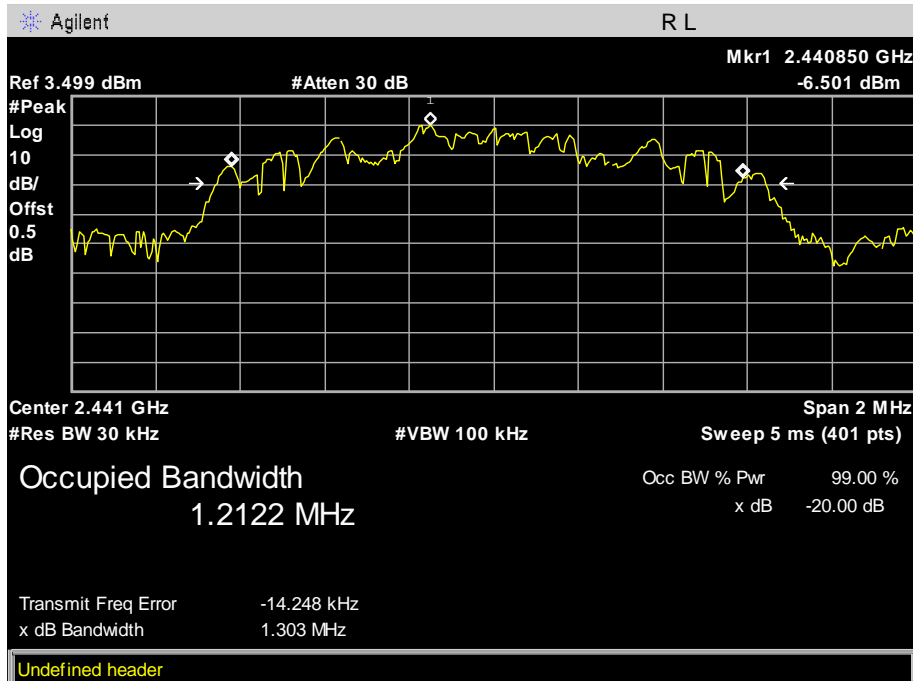

### CH78 -2Mbps

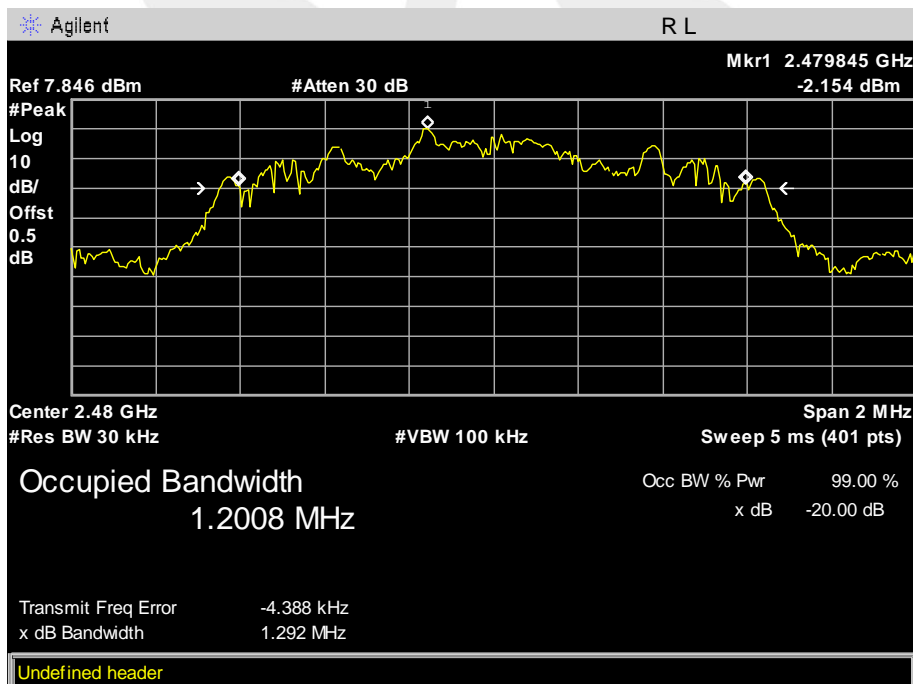



|               |                              |                     |            |
|---------------|------------------------------|---------------------|------------|
| EUT :         | smart phone                  | Model Name :        | Ilium L200 |
| Temperature : | 25 °C                        | Relative Humidity : | 50%        |
| Pressure :    | 1012 hPa                     | Test Voltage :      | DC 3.7V    |
| Test Mode :   | 8DPSK(3Mbps)CH00 / CH39 /C78 |                     |            |

| Frequency | 20dB Bandwidth (MHz) | Result |
|-----------|----------------------|--------|
| 2402 MHz  | 1.241                | PASS   |
| 2441 MHz  | 1.269                | PASS   |
| 2480 MHz  | 1.277                | PASS   |

CH00 -3Mbps

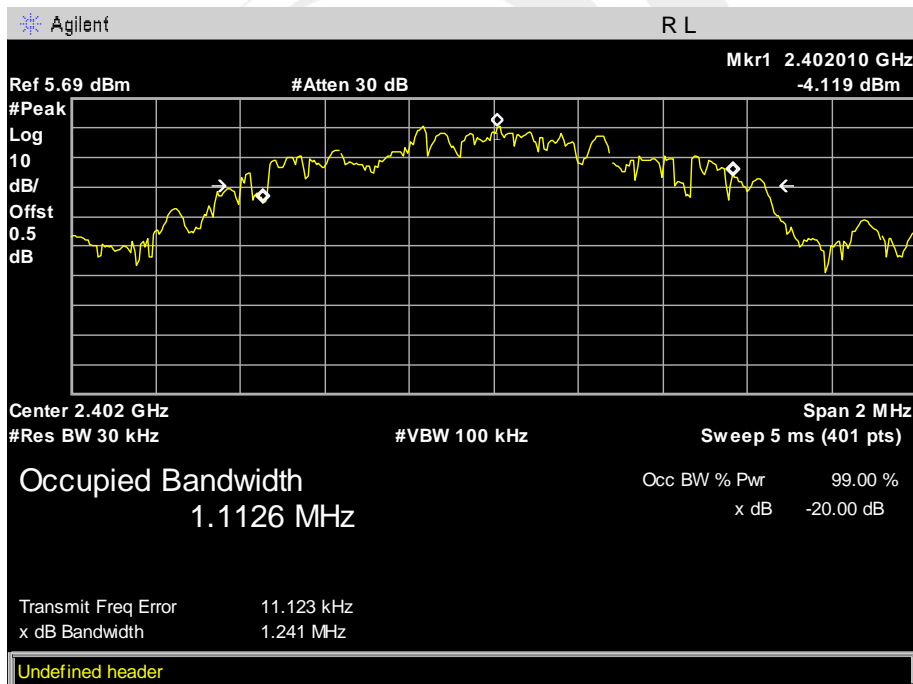



### CH39 -3Mbps

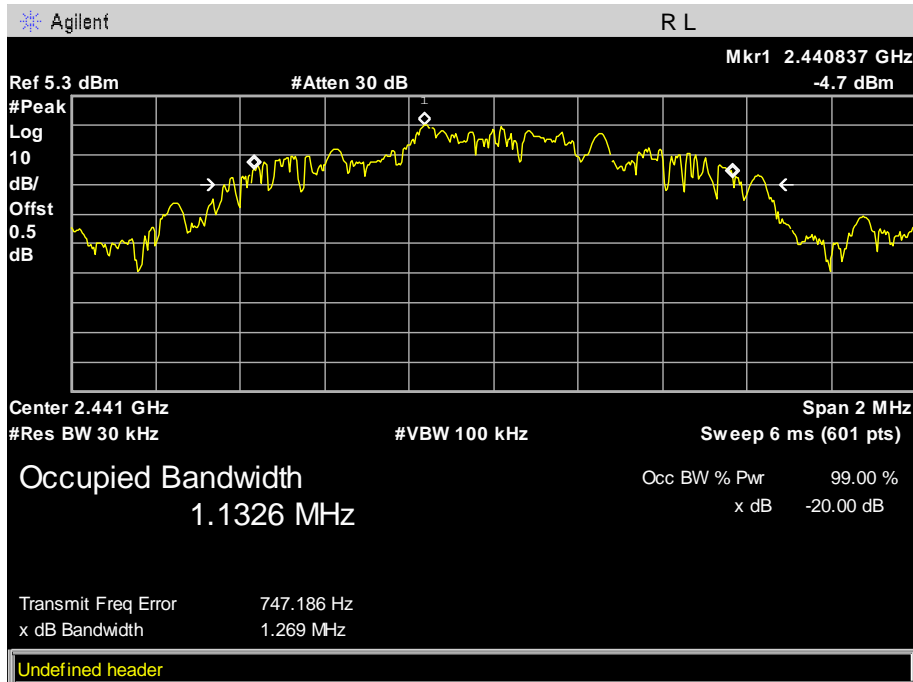

### CH78 -3Mbps

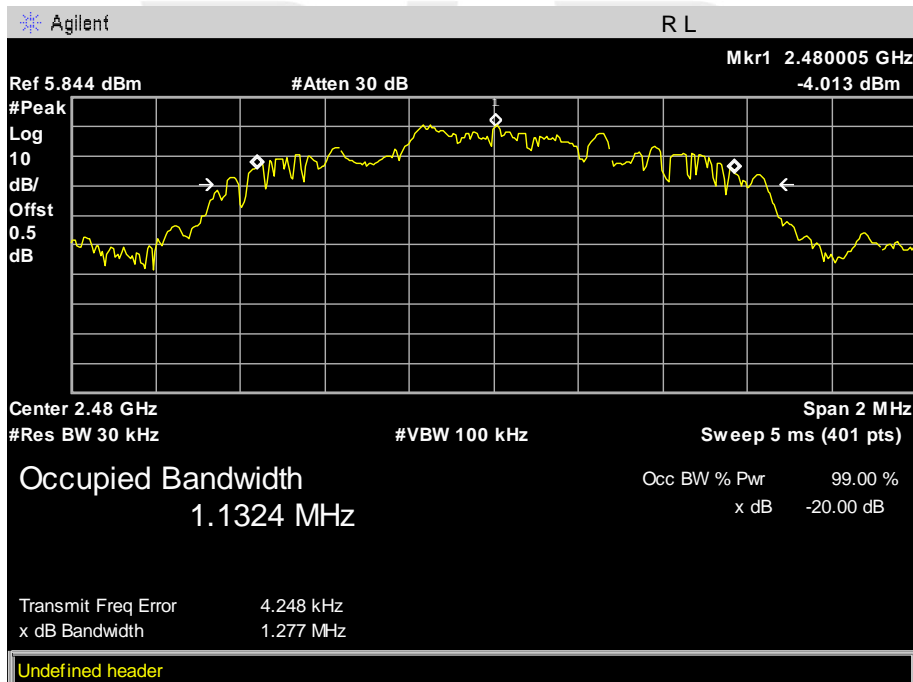



## 9. PEAK OUTPUT POWER TEST

### 9.1 APPLIED PROCEDURES / LIMIT

| FCC Part15 (15.247) , Subpart C |                   |  |                       |        |
|---------------------------------|-------------------|--|-----------------------|--------|
| Section                         | Test Item         | Limit  | Frequency Range (MHz) | Result |
| 15.247 (b)(i)                   | Peak Output Power | 1 W or 0.125W  | 2400-2483.5           | PASS   |
|                                 |                   | Or if channel separation > 2/3 bandwidth provided the systems operate with an output power no greater than 125 mW (20.96dBm) |                       |        |

### 9.2 TEST PROCEDURE

- The EUT was directly connected to the spectrum analyzer and antenna output port as show in the block diagram below,
- Spectrum Setting : GFSK(1Mbps):RBW= 1MHz, VBW= 3MHz, Sweep time = Auto.
- Spectrum Setting :  $\pi/4$ -DQPSK(2Mbps):RBW= 3MHz, VBW= 3MHz, Sweep time = Auto.
- Spectrum Setting : 8-DPSK(3Mbps):RBW= 3MHz, VBW= 3MHz, Sweep time = Auto.

### 9.3 TEST SETUP



### 9.4 EUT OPERATION CONDITIONS

The EUT tested system was configured as the statements of 2.4 Unless otherwise a special operating condition is specified in the follows during the testing.



9.5 TEST RESULTS

|               |                              |                     |            |
|---------------|------------------------------|---------------------|------------|
| EUT :         | smart phone                  | Model Name :        | Ilium L200 |
| Temperature : | 25 °C                        | Relative Humidity : | 60%        |
| Pressure :    | 1012 hPa                     | Test Voltage :      | DC 3.7V    |
| Test Mode :   | CH00/ CH39 /CH78 GFSK(1Mbps) |                     |            |

| Test Channel | Frequency (MHz) | Peak Output Power (dBm) | LIMIT (dBm) |
|--------------|-----------------|-------------------------|-------------|
| CH00         | 2402            | 0.622                   | 30          |
| CH39         | 2441            | -2.327                  | 30          |
| CH78         | 2480            | 0.887                   | 30          |

Note : the channel separation > bandwidth

CH00 -1Mbps

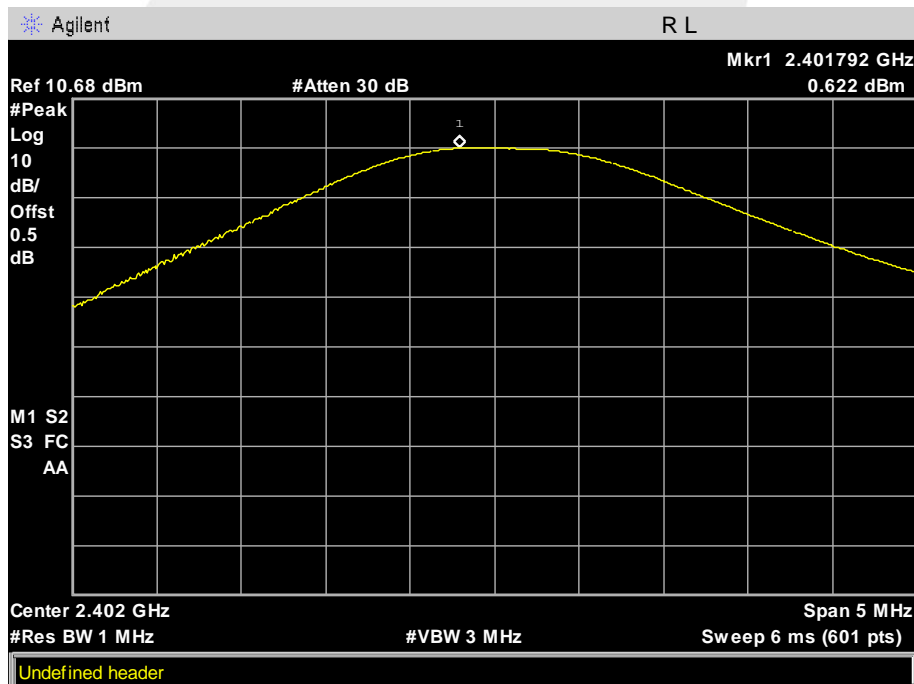



### CH39 -1Mbps

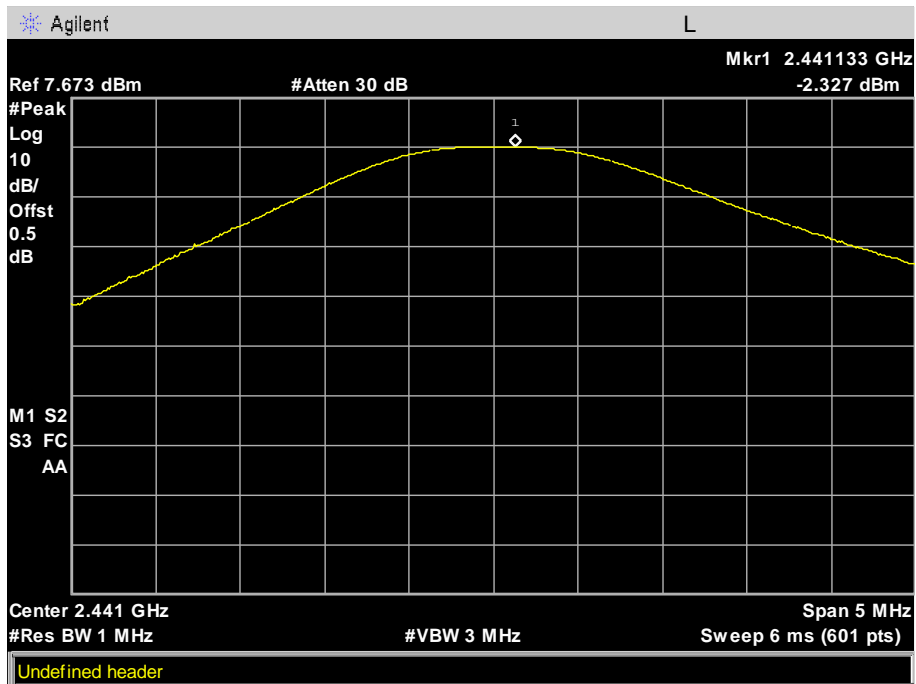

### CH78 -1Mbps

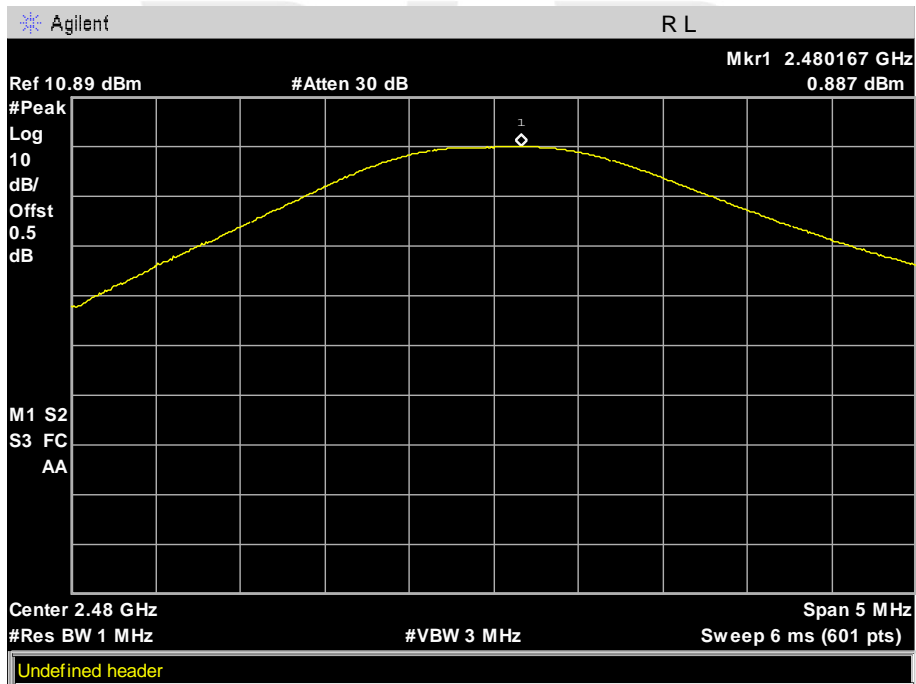



|               |  |                     |            |
|---------------|--|---------------------|------------|
| EUT :         | smart phone                            | Model Name :        | Ilium L200 |
| Temperature : | 25 °C                                  | Relative Humidity : | 60%        |
| Pressure :    | 1012 hPa                               | Test Voltage :      | DC 3.7V    |
| Test Mode :   | CH00/ CH39 /CH78 $\pi/4$ -DQPSK(2Mbps) |                     |            |

| Test Channel | Frequency (MHz) | Peak Output Power (dBm) | LIMIT (dBm) |
|--------------|-----------------|-------------------------|-------------|
| CH00         | 2402            | 0.041                   | 20.96       |
| CH39         | 2441            | -2.658                  | 20.96       |
| CH78         | 2480            | 0.269                   | 20.96       |

Note : the channel separation >2/3 bandwidth

CH00 -2Mbps

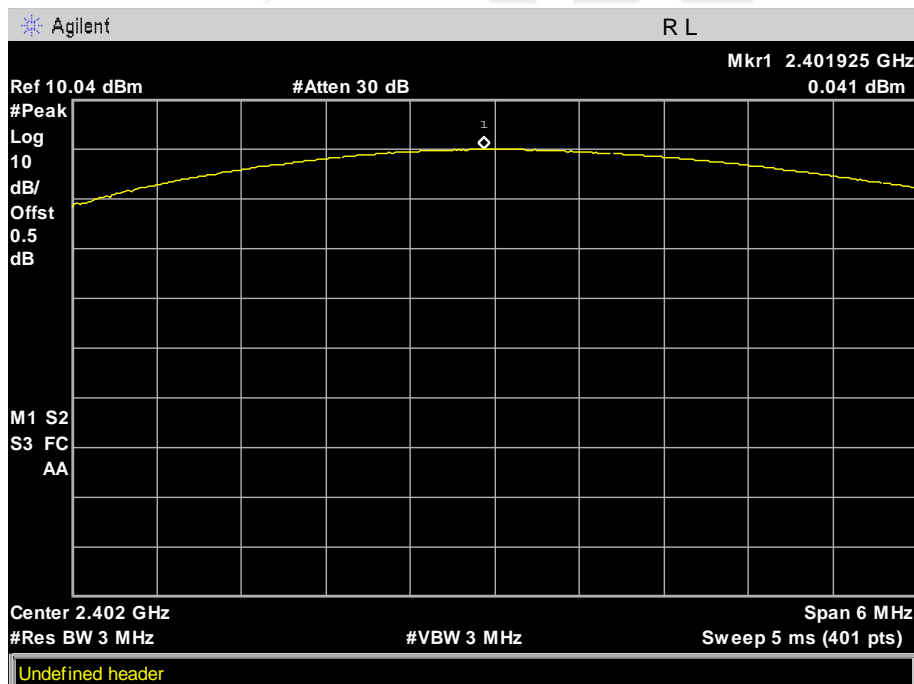





### CH39 -2Mbps

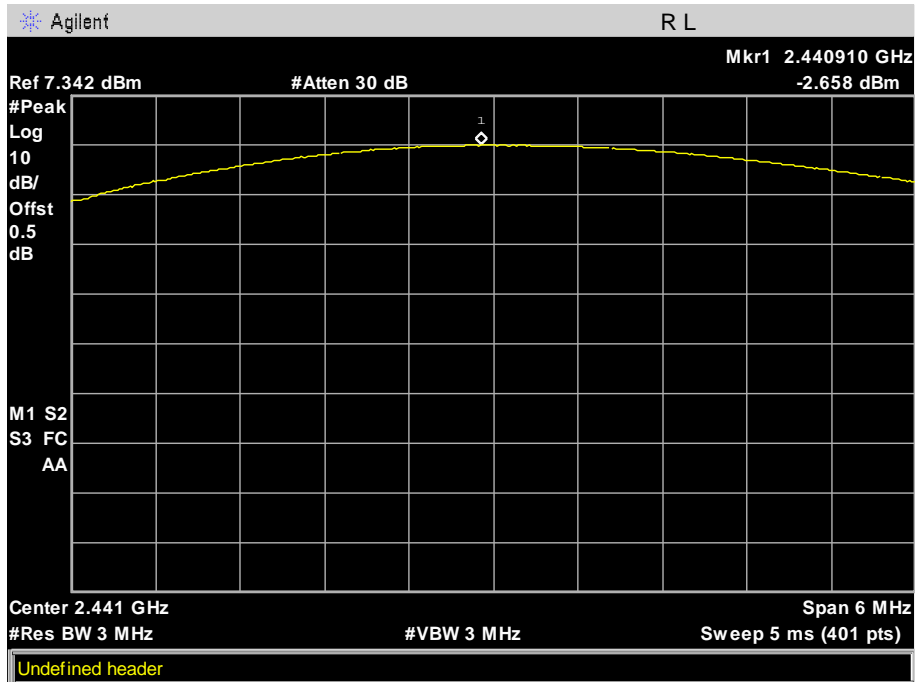

### CH78 -2Mbps

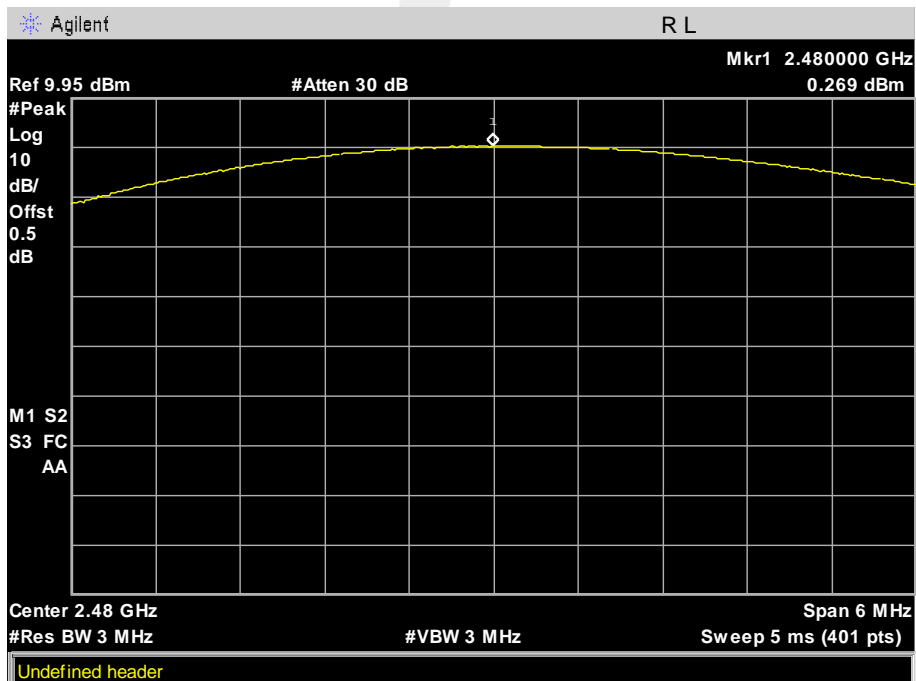



|               |                                |                     |            |
|---------------|--------------------------------|---------------------|------------|
| EUT :         | smart phone                    | Model Name :        | Ilium L200 |
| Temperature : | 25 °C                          | Relative Humidity : | 60%        |
| Pressure :    | 1012 hPa                       | Test Voltage :      | DC 3.7V    |
| Test Mode :   | CH00/ CH39 /CH78 8-DPSK(3Mbps) |                     |            |

| Test Channel | Frequency (MHz) | Peak Output Power (dBm) | LIMIT (dBm) |
|--------------|-----------------|-------------------------|-------------|
| CH00         | 2402            | 0.284                   | 20.96       |
| CH39         | 2441            | -2.407                  | 20.96       |
| CH78         | 2480            | 0.689                   | 20.96       |

Note : the channel separation >2/3 bandwidth

CH00 -3Mbps

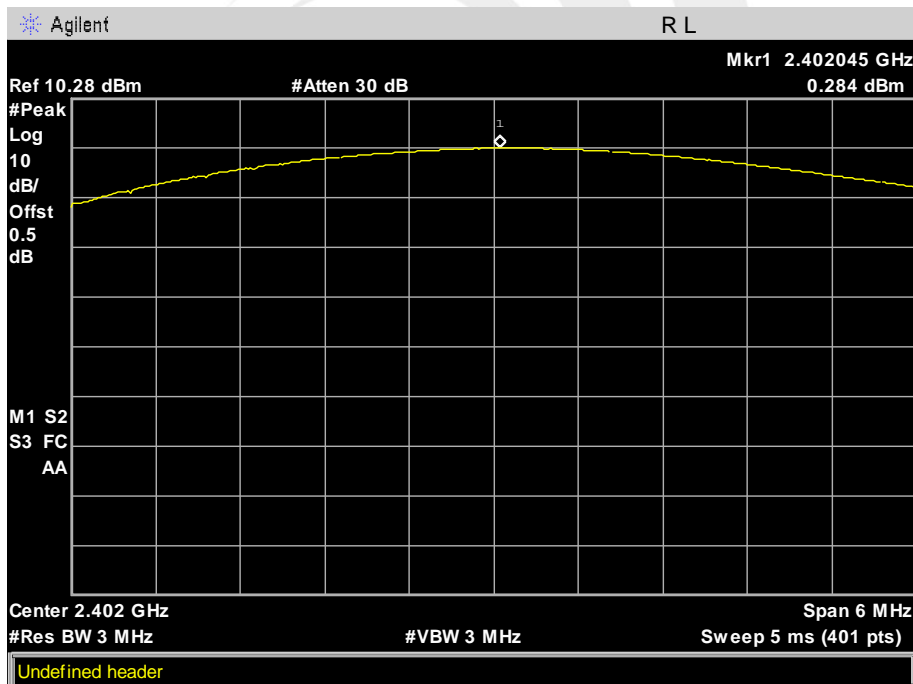



### CH39 -3Mbps

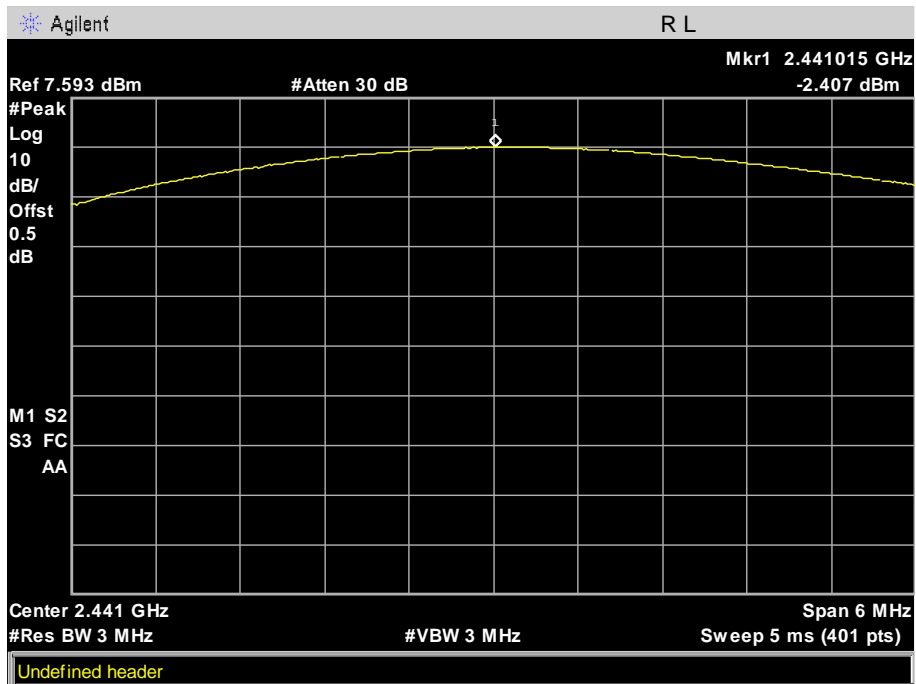

### CH78 -3Mbps

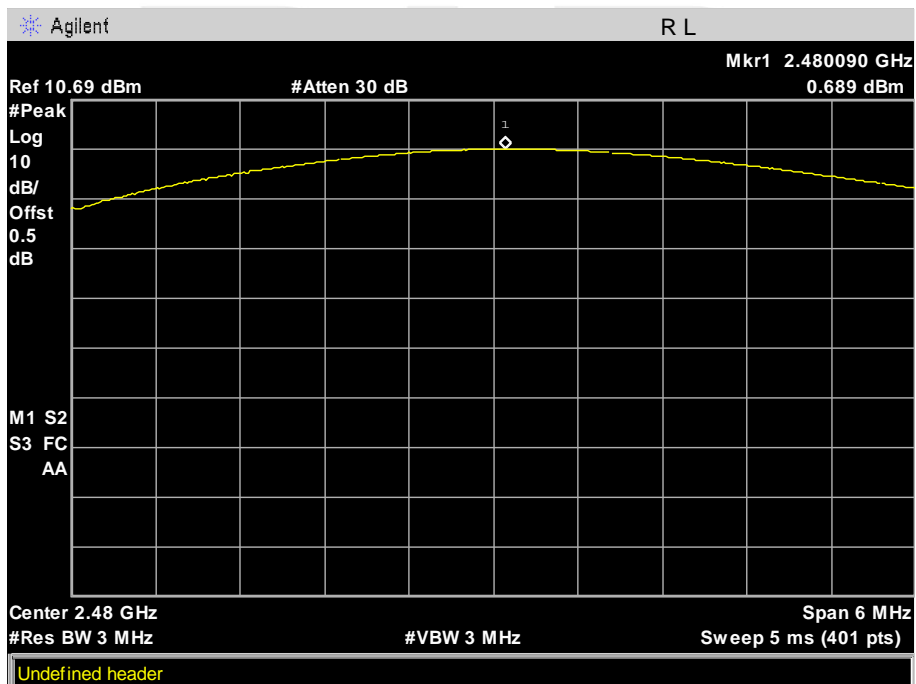



## 10. ANTENNA REQUIREMENT

### 10.1 STANDARD REQUIREMENT

15.203 requirement: For intentional device, according to 15.203: an intentional radiator shall be designed to ensure that no antenna other than that furnished by the responsible party shall be used with the device.

### 10.2 EUT ANTENNA

The EUT antenna is permanent attach Antenna. It comply with the standard requirement.



## APPENDIX- PHOTOS OF TEST SETUP

### Radiated Measurement Photos

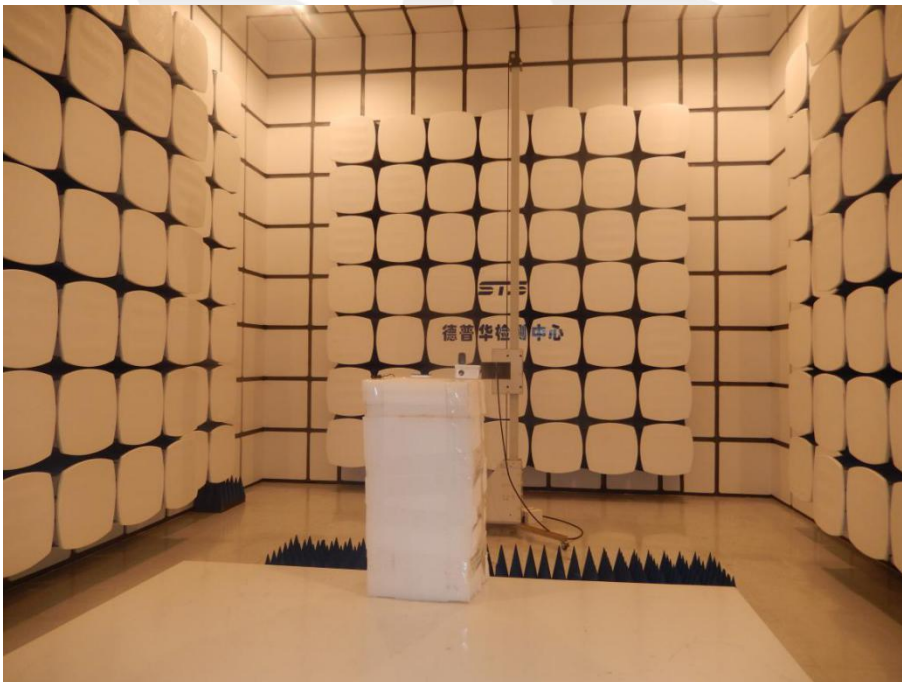
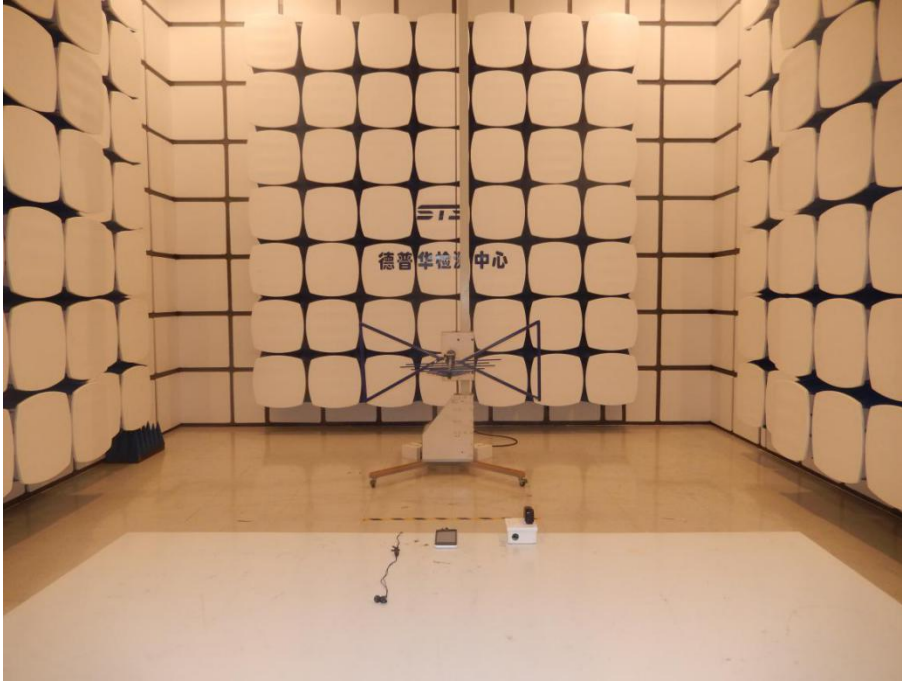

### Conducted Measurement Photos



\*\*\*\*\*END OF THE REPORT\*\*\*\*\*