

FCC TEST REPORT

(Part 15, Subpart E)



Applicant:	Corporativo Lanix S.A. de C.V.
Address:	Carretera Internacional Hermosillo-Nogales Km 8.5, Hermosillo Sonora, Mexico

Manufacturer or Supplier:	Corporativo Lanix S.A. de C.V.
Address:	Carretera Internacional Hermosillo-Nogales Km 8.5, Hermosillo Sonora, Mexico
Product:	Mobile Phone
Brand Name:	Lanix
Model Name:	Ilium Alpha 9
FCC ID:	ZC4ALPHA9
Date of tests:	May 24, 2018 ~ Jun. 12, 2018

The tests have been carried out according to the requirements of the following standard:

FCC Part 15, Subpart E, Section 15.407

CONCLUSION: The submitted sample was found to COMPLY with the test requirement

Prepared by Roger Li Engineer / Mobile Department	Approved by Sam Tung Manager / Mobile Department
	
Date: Jun. 13, 2018	Date: Jun. 13, 2018

This report is governed by, and incorporates by reference, CPS Conditions of Service as posted at the date of issuance of this report at <http://www.bureauveritas.com/home/about-us/our-business/cps/about-us/terms-conditions> and is intended for your exclusive use. Any copying or replication of this report to or for any other person or entity, or use of our name or trademark, is permitted only with our prior written permission. This report sets forth our findings solely with respect to the test samples identified herein. The results set forth in this report are not indicative or representative of the quality or characteristics of the lot from which a test sample was taken or any similar or identical product unless specifically and expressly noted. Our report includes all of the tests requested by you and the results thereof based upon the information that you provided to us. Measurement uncertainty is only provided upon request for accredited tests. You have 60 days from date of issuance of this report to notify us of any material error or omission caused by our negligence or if you require measurement uncertainty; provided, however, that such notice shall be in writing and shall specifically address the issue you wish to raise. A failure to raise such issue within the prescribed time shall constitute your unqualified acceptance of the completeness of this report, the tests conducted and the correctness of the report contents.



TABLE OF CONTENTS

RELEASE CONTROL RECORD 4

1 SUMMARY OF TEST RESULTS..... 5

1.1 MEASUREMENT UNCERTAINTY 5

2 GENERAL INFORMATION 6

2.1 GENERAL DESCRIPTION OF EUT 6

2.2 DESCRIPTION OF TEST MODES 8

2.2.1 TEST MODE APPLICABILITY AND TESTED CHANNEL DETAIL..... 10

2.3 DUTY CYCLE OF TEST SIGNAL 13

2.4 DESCRIPTION OF SUPPORT UNITS 14

2.4.1 CONFIGURATION OF SYSTEM UNDER TEST 15

2.5 GENERAL DESCRIPTION OF APPLIED STANDARDS 15

3 TEST TYPES AND RESULTS..... 16

3.1 RADIATED EMISSION AND BANDEDGE MEASUREMENT 16

3.1.1 LIMITS OF RADIATED EMISSION AND BANDEDGE MEASUREMENT..... 16

3.1.2 LIMITS OF UNWANTED EMISSION 17

3.1.3 TEST INSTRUMENTS 18

3.1.4 TEST PROCEDURES 19

3.1.5 DEVIATION FROM TEST STANDARD 19

3.1.6 TEST SETUP 20

3.1.7 EUT OPERATING CONDITION 21

3.1.8 TEST RESULTS 22

3.2 CONDUCTED EMISSION MEASUREMENT 70

3.2.1 LIMITS OF CONDUCTED EMISSION MEASUREMENT 70

3.2.2 TEST INSTRUMENTS 70

3.2.3 TEST PROCEDURES 70

3.2.4 DEVIATION FROM TEST STANDARD 71

3.2.5 TEST SETUP 71

3.2.6 EUT OPERATING CONDITIONS 71

3.2.7 TEST RESULTS 72

3.3 MAXIMUM CONDUCTED OUTPUT POWER MEASUREMENT 74

3.3.1 LIMITS OF MAXIMUM CONDUCTED OUTPUT POWER MEASUREMENT 74

3.3.2 TEST SETUP 75



3.3.3	TEST INSTRUMENTS.....	75
3.3.4	TEST PROCEDURE.....	76
3.3.5	DEVIATION FROM TEST STANDARD	78
3.3.6	EUT OPERATING CONDITIONS	78
3.3.7	TEST RESULTS	79
3.4	MAXIMUM POWER SPECTRAL DENSITY MEASUREMENT.....	92
3.4.1	LIMITS OF MAXIMUM POWER SPECTRAL DENSITY MEASUREMENT	92
3.4.2	TEST SETUP.....	92
3.4.3	TEST INSTRUMENTS.....	92
3.4.4	TEST PROCEDURES	93
3.4.5	DEVIATION FROM TEST STANDARD	93
3.4.6	EUT OPERATING CONDITIONS	93
3.4.7	TEST RESULTS	94
3.5	FREQUENCY STABILITY	101
3.5.1	LIMITS OF FREQUENCY STABILITY MEASUREMENT.....	101
3.5.2	TEST SETUP.....	101
3.5.3	TEST INSTRUMENTS.....	101
3.5.4	TEST PROCEDURE.....	102
3.5.5	DEVIATION FROM TEST STANDARD	102
3.5.6	EUT OPERATING CONDITION	102
3.5.7	TEST RESULTS	103
4	PHOTOGRAPHS OF THE TEST CONFIGURATION.....	105
5	APPENDIX A – MODIFICATIONS RECORDERS FOR ENGINEERING CHANGES TO THE EUT BY THE LAB.....	106



BUREAU
VERITAS

Test Report No.: RF180523W002-3

RELEASE CONTROL RECORD

ISSUE NO.	REASON FOR CHANGE	DATE ISSUED
RF180523W002-3	Original release	Jun. 13, 2018



1 SUMMARY OF TEST RESULTS

The EUT has been tested according to the following specifications:

APPLIED STANDARD: FCC PART 15, SUBPART E (SECTION 15.407)			
STANDARD SECTION	TEST TYPE AND LIMIT	RESULT	REMARK
15.407(b)(5)	AC Power Conducted Emission	PASS	Meet the requirement of limit. Minimum passing margin is -8.48dB at 0.170000MHz.
15.407(b) (1/2/3/4/6)	Radiated Emission & Band Edge Measurement	PASS	Meet the requirement of limit. Minimum passing margin is -1.54dB at 5725.00MHz.
15.407(a/1/2/3)	Maximum conducted output Power	PASS	Meet the requirement of limit.
15.407(a/1/2/3)	Peak Power Spectral Density	PASS	Meet the requirement of limit.
15.407(e)	6 dB Bandwidth	PASS	Meet the requirement of limit. (U-NII-3 Band only)
15.407(g)	Frequency Stability	PASS	Meet the requirement of limit.
15.203	Antenna Requirement	PASS	No antenna connector is used.

1.1 MEASUREMENT UNCERTAINTY

Where relevant, the following measurement uncertainty levels have been estimated for tests performed on the EUT as specified in CISPR 16-4-2:

MEASUREMENT	FREQUENCY	UNCERTAINTY
Conducted emissions	9kHz~30MHz	2.66dB
Radiated emissions	9KHz ~ 30MHz	2.68dB
	30MHz ~ 1GMHz	3.26dB
	1GHz ~ 18GHz	4.48dB
	18GHz ~ 40GHz	4.12dB

This uncertainty represents an expanded uncertainty expressed at approximately the 95% confidence level using a coverage factor of $k = 2$.



2 GENERAL INFORMATION

2.1 GENERAL DESCRIPTION OF EUT

EUT	Mobile Phone
MODEL NO.	Ilium Alpha 9
POWER SUPPLY	5Vdc (adapter or host equipment) 3.85Vdc (Li-ion, battery)
MODULATION TYPE	64QAM, 16QAM, QPSK, BPSK
MODULATION TECHNOLOGY	OFDM
TRANSFER RATE	802.11a: 54.0/ 48.0/ 36.0/ 24.0/ 18.0/ 12.0/ 9.0/ 6.0Mbps 802.11n: up to MCS7 802.11ac: up to 390.0Mbps
OPERATING FREQUENCY	5180 ~ 5240MHz, 5260 ~ 5320MHz, 5500 ~ 5700MHz, 5745 ~ 5825MHz
NUMBER OF CHANNEL	5180 ~ 5240MHz: 4 for 802.11a, 802.11n (20MHz) 2 for 802.11n (40MHz) 1 for 802.11ac (80MHz) 5260 ~ 5320MHz: 4 for 802.11a, 802.11n (20MHz) 2 for 802.11n (40MHz) 1 for 802.11ac (80MHz) 5500 ~ 5700MHz: 8 for 802.11a, 802.11n (20MHz) 3 for 802.11n (40MHz) 1 for 802.11ac (80MHz) 5745 ~ 5825MHz: 5 for 802.11a, 802.11n (20MHz) 2 for 802.11n (40MHz) 1 for 802.11ac (80MHz)
AVERAGE POWER	35.075mW for 5180 ~ 5240MHz 31.550mW for 5260 ~ 5320MHz 40.926mW for 5500 ~ 5700MHz 36.058mW for 5745 ~ 5825MHz
ANTENNA TYPE	Fixed Internal Antenna
ANTENNA GAIN	2.11dBi for 5180 ~ 5240MHz 2.35dBi for 5260 ~ 5320MHz 2.43dBi for 5500 ~ 5700MHz 2.31dBi for 5745 ~ 5825MHz
HW VERSION	1.0
SW VERSION	Ilium Alpha 9_SW_01
I/O PORTS	Refer to user's manual



CABLE SUPPLIED	USB cable: non-shielded, detachable, 1.0meter Earphone cable: non-shielded, detachable, 1.2meter Tieline: non-shielded, detachable, 0.1meter
-----------------------	--

NOTE:

- For a more detailed features description, please refer to the manufacturer's specifications or the user's manual.
- The EUT was powered by the following adapter and WPC:

ADAPTER	
BRAND:	Lanix
MODEL:	Ilium Alpha 9-C
INPUT:	AC 100-240V, 350mA
OUTPUT:	DC 5V, 2000mA

WIRELESS POWER CONSORTIUM (WPC)	
BRAND:	Lanix
MODEL:	Ilium Alpha 9-W
INPUT:	5/9V, 2000mA
OUTPUT:	10W, MAX

- The EUT matched the following USB cable & earphone and tieline:

USB CABLE	
BRAND:	Lanix
MODEL:	CY-Type-C
SIGNAL LINE:	1.0 METER

EARPHONE	
BRAND:	Lanix
MODEL:	GN-EP02C
SIGNAL LINE:	1.2 METER

TIELINE	
BRAND:	Lanix
MODEL:	CY-C-3.5mm
SIGNAL LINE:	0.1 METER

- The EUT incorporates a SISO function. Physically, the EUT provides one completed transmitter and one receiver.

MODULATION MODE	TX FUNCTION
802.11a	1TX/1RX
802.11n (20MHz)	1TX/1RX
802.11n (40MHz)	1TX/1RX
802.11ac (80MHz)	1TX/1RX

- For the test results, the EUT had been tested with all conditions. But only the worst case was shown in test report.



2.2 DESCRIPTION OF TEST MODES

FOR 5150 ~ 5250MHz

4 channels are provided for 802.11a, 802.11n (20MHz):

CHANNEL	FREQUENCY	CHANNEL	FREQUENCY
36	5180 MHz	44	5220 MHz
40	5200 MHz	48	5240 MHz

2 channels are provided for 802.11n (40MHz):

CHANNEL	FREQUENCY	CHANNEL	FREQUENCY
38	5190 MHz	46	5230 MHz

1 channel is provided for 802.11ac (80MHz):

CHANNEL	FREQUENCY	CHANNEL	FREQUENCY
42	5210 MHz		

FOR 5250 ~ 5350MHz

4 channels are provided for 802.11a, 802.11n (20MHz):

CHANNEL	FREQUENCY	CHANNEL	FREQUENCY
52	5260 MHz	60	5300 MHz
56	5280 MHz	64	5320 MHz

2 channels are provided for 802.11n (40MHz):

CHANNEL	FREQUENCY	CHANNEL	FREQUENCY
54	5270 MHz	62	5310 MHz

1 channel is provided for 802.11ac (80MHz):

CHANNEL	FREQUENCY	CHANNEL	FREQUENCY
58	5290 MHz		



FOR 5470 ~ 5725MHz

8 channels are provided for 802.11a, 802.11n (20MHz):

CHANNEL	FREQUENCY	CHANNEL	FREQUENCY
100	5500 MHz	116	5580 MHz
104	5520 MHz	132	5660 MHz
108	5540 MHz	136	5680 MHz
112	5560 MHz	140	5700 MHz

3 channels are provided for 802.11n (40MHz):

CHANNEL	FREQUENCY	CHANNEL	FREQUENCY
102	5510 MHz	134	5670 MHz
110	5550 MHz		

1 channel is provided for 802.11ac (80MHz):

CHANNEL	FREQUENCY	CHANNEL	FREQUENCY
106	5530 MHz		

FOR 5725 ~ 5825MHz

5 channels are provided for 802.11a, 802.11n (20MHz):

CHANNEL	FREQUENCY	CHANNEL	FREQUENCY
149	5745 MHz	161	5805 MHz
153	5765 MHz	165	5825 MHz
157	5785 MHz		

2 channels are provided for 802.11n (40MHz):

CHANNEL	FREQUENCY	CHANNEL	FREQUENCY
151	5755 MHz	159	5795 MHz

1 channel is provided for 802.11ac (80MHz):

CHANNEL	FREQUENCY	CHANNEL	FREQUENCY
155	5775 MHz		



2.2.1 TEST MODE APPLICABILITY AND TESTED CHANNEL DETAIL

EUT CONFIGURE MODE	APPLICABLE TO				DESCRIPTION
	RE≥1G	RE<1G	PLC	APCM	
A	√	√	√	-	Powered by Adapter with wifi(5G) link
B	-	-	-	√	Powered by Battery with wifi(5G) link
C	-	-	-	-	Powered by USB with wifi(5G) link

Where **RE≥1G**: Radiated Emission above 1GHz **RE<1G**: Radiated Emission below 1GHz
PLC: Power Line Conducted Emission **APCM**: Antenna Port Conducted Measurement

NOTE:
The EUT had been pre-tested on the positioned of each 3 axis. The worst case was found when positioned on **X-plane**.
NOTE: "-" means no effect.

RADIATED EMISSION TEST (ABOVE 1GHz):

- Pre-Scan has been conducted to determine the worst-case mode from all possible combinations between available modulations, data rates and antenna ports (if EUT with antenna diversity architecture).
- Following channel(s) was (were) selected for the final test as listed below.

EUT CONFIGURE MODE	MODE	FREQ. BAND (MHz)	AVAILABLE CHANNEL	TESTED CHANNEL	MODULATION TECHNOLOGY	MODULATION TYPE	DATA RATE (Mbps)
A	802.11a	5180-5240	36 to 48	36, 40, 48	OFDM	BPSK	6.0
A	802.11n (20MHz)		36 to 48	36, 40, 48	OFDM	BPSK	MCS0
A	802.11n (40MHz)		38 to 46	38, 46	OFDM	BPSK	MCS0
A	802.11ac (80MHz)		42	42	OFDM	BPSK	V0
A	802.11a	5260-5320	52 to 64	52, 60, 64	OFDM	BPSK	6.0
A	802.11n (20MHz)		52 to 64	52, 60, 64	OFDM	BPSK	MCS0
A	802.11n (40MHz)		54 to 62	54, 62	OFDM	BPSK	MCS0
A	802.11ac (80MHz)		58	58	OFDM	BPSK	V0
A	802.11a	5500-5700	100 to 140	100, 116, 140	OFDM	BPSK	6.0
A	802.11n (20MHz)		100 to 140	100, 116, 140	OFDM	BPSK	MCS0
A	802.11n (40MHz)		102 to 134	102, 110, 134	OFDM	BPSK	MCS0
A	802.11ac (80MHz)		106	106	OFDM	BPSK	V0
A	802.11a	5725-5825	149 to 165	149, 157, 165	OFDM	BPSK	6.0
A	802.11n (20MHz)		149 to 165	149, 157, 165	OFDM	BPSK	MCS0
A	802.11n (40MHz)		151 to 159	151, 159	OFDM	BPSK	MCS0
A	802.11ac (80MHz)		155	155	OFDM	BPSK	V0



RADIATED EMISSION TEST (BELOW 1GHz):

- Pre-Scan has been conducted to determine the worst-case mode from all possible combinations between available modulations, data rates and antenna ports (if EUT with antenna diversity architecture).
- Following channel(s) was (were) selected for the final test as listed below.

EUT CONFIGURE MODE	MODE	FREQ. BAND (MHz)	AVAILABLE CHANNEL	TESTED CHANNEL	MODULATION TECHNOLOGY	MODULATION TYPE	DATA RATE (Mbps)
A	802.11n (20MHz)	5500-5700	100 to 140	140	OFDM	BPSK	MCS0

POWER LINE CONDUCTED EMISSION TEST:

- Pre-Scan has been conducted to determine the worst-case mode from all possible combinations between available modulations, data rates and antenna ports (if EUT with antenna diversity architecture).
- Following channel(s) was (were) selected for the final test as listed below.

EUT CONFIGURE MODE	MODE	FREQ. BAND (MHz)	AVAILABLE CHANNEL	TESTED CHANNEL	MODULATION TECHNOLOGY	MODULATION TYPE	DATA RATE (Mbps)
A	802.11n (20MHz)	5500-5700	100 to 140	140	OFDM	BPSK	MCS0

BANDEDGE MEASUREMENT:

- Pre-Scan has been conducted to determine the worst-case mode from all possible combinations between available modulations, data rates and antenna ports (if EUT with antenna diversity architecture).
- Following channel(s) was (were) selected for the final test as listed below.

EUT CONFIGURE MODE	MODE	FREQ. BAND (MHz)	AVAILABLE CHANNEL	TESTED CHANNEL	MODULATION TECHNOLOGY	MODULATION TYPE	DATA RATE (Mbps)
A	802.11a	5180-5240	36 to 48	36, 48	OFDM	BPSK	6.0
A	802.11n (20MHz)		36 to 48	36, 48	OFDM	BPSK	MCS0
A	802.11n (40MHz)		38 to 46	38, 46	OFDM	BPSK	MCS0
A	802.11ac (80MHz)		42	42	OFDM	BPSK	V0
A	802.11a	5260-5320	52 to 64	52, 64	OFDM	BPSK	6.0
A	802.11n (20MHz)		52 to 64	52, 64	OFDM	BPSK	MCS0
A	802.11n (40MHz)		54 to 62	54, 62	OFDM	BPSK	MCS0
A	802.11ac (80MHz)		58	58	OFDM	BPSK	V0
A	802.11a	5500-5700	100 to 140	100, 140	OFDM	BPSK	6.0
A	802.11n (20MHz)		100 to 140	100, 140	OFDM	BPSK	MCS0
A	802.11n (40MHz)		102 to 134	102, 134	OFDM	BPSK	MCS0
A	802.11ac (80MHz)		106	106	OFDM	BPSK	V0
A	802.11a	5725-5825	149 to 165	149, 165	OFDM	BPSK	6.0
A	802.11n (20MHz)		149 to 165	149, 165	OFDM	BPSK	MCS0
A	802.11n (40MHz)		151 to 159	151, 159	OFDM	BPSK	MCS0
A	802.11ac (80MHz)		155	155	OFDM	BPSK	V0

**ANTENNA PORT CONDUCTED MEASUREMENT:**

- This item includes all test value of each mode, but only includes spectrum plot of worst value of each mode.
- Pre-Scan has been conducted to determine the worst-case mode from all possible combinations between available modulations, data rates and antenna ports (if EUT with antenna diversity architecture).
- Following channel(s) was (were) selected for the final test as listed below.

EUT CONFIGURE MODE	MODE	FREQ. BAND (MHz)	AVAILABLE CHANNEL	TESTED CHANNEL	MODULATION TECHNOLOGY	MODULATION TYPE	DATA RATE (Mbps)
B	802.11a	5180-5240	36 to 48	36, 40, 48	OFDM	BPSK	6.0
B	802.11n (20MHz)		36 to 48	36, 40, 48	OFDM	BPSK	MCS0
B	802.11n (40MHz)		38 to 46	38, 46	OFDM	BPSK	MCS0
B	802.11ac (80MHz)		42	42	OFDM	BPSK	V0
B	802.11a	5260-5320	52 to 64	52, 60, 64	OFDM	BPSK	6.0
B	802.11n (20MHz)		52 to 64	52, 60, 64	OFDM	BPSK	MCS0
B	802.11n (40MHz)		54 to 62	54, 62	OFDM	BPSK	MCS0
B	802.11ac (80MHz)		58	58	OFDM	BPSK	V0
B	802.11a	5500-5700	100 to 140	100, 116, 140	OFDM	BPSK	6.0
B	802.11n (20MHz)		100 to 140	100, 116, 140	OFDM	BPSK	MCS0
B	802.11n (40MHz)		102 to 134	102, 110, 134	OFDM	BPSK	MCS0
B	802.11ac (80MHz)		106	106	OFDM	BPSK	V0
B	802.11a	5725-5825	149 to 165	149, 165	OFDM	BPSK	6.0
B	802.11n (20MHz)		149 to 165	149, 165	OFDM	BPSK	MCS0
B	802.11n (40MHz)		151 to 159	151, 159	OFDM	BPSK	MCS0
B	802.11ac (80MHz)		155	155	OFDM	BPSK	V0

TEST CONDITION:

APPLICABLE TO	ENVIRONMENTAL CONDITIONS	INPUT POWER	TESTED BY
RE<1G	23deg. C, 62%RH	DC 5V from adaptor	Vincent
RE≥1G	23deg. C, 62%RH	DC 5V from adaptor	Vincent
PLC	24deg. C, 61%RH	DC 5V from adaptor	John Wen
APCM	23.5deg. C, 60%RH	DC 3.85V By battery	Wenliang Wu



2.3 DUTY CYCLE OF TEST SIGNAL

Duty cycle of test signal is < 98%, duty factor shall be considered.

802.11a: Duty cycle = 1.389/1.428 = 0.973, Duty factor = 10 * log(1/0.973) = 0.12

802.11n (20MHz): Duty cycle = 1.296/1.355 = 0.956, Duty factor = 10 * log(1/0.956) = 0.19

802.11n (40MHz): Duty cycle = 0.648/0.687 = 0.943, Duty factor = 10 * log(1/0.943) = 0.25

802.11ac (80MHz): Duty cycle = 0.322/0.360 = 0.894, Duty factor = 10 * log(1/0.894) = 0.48

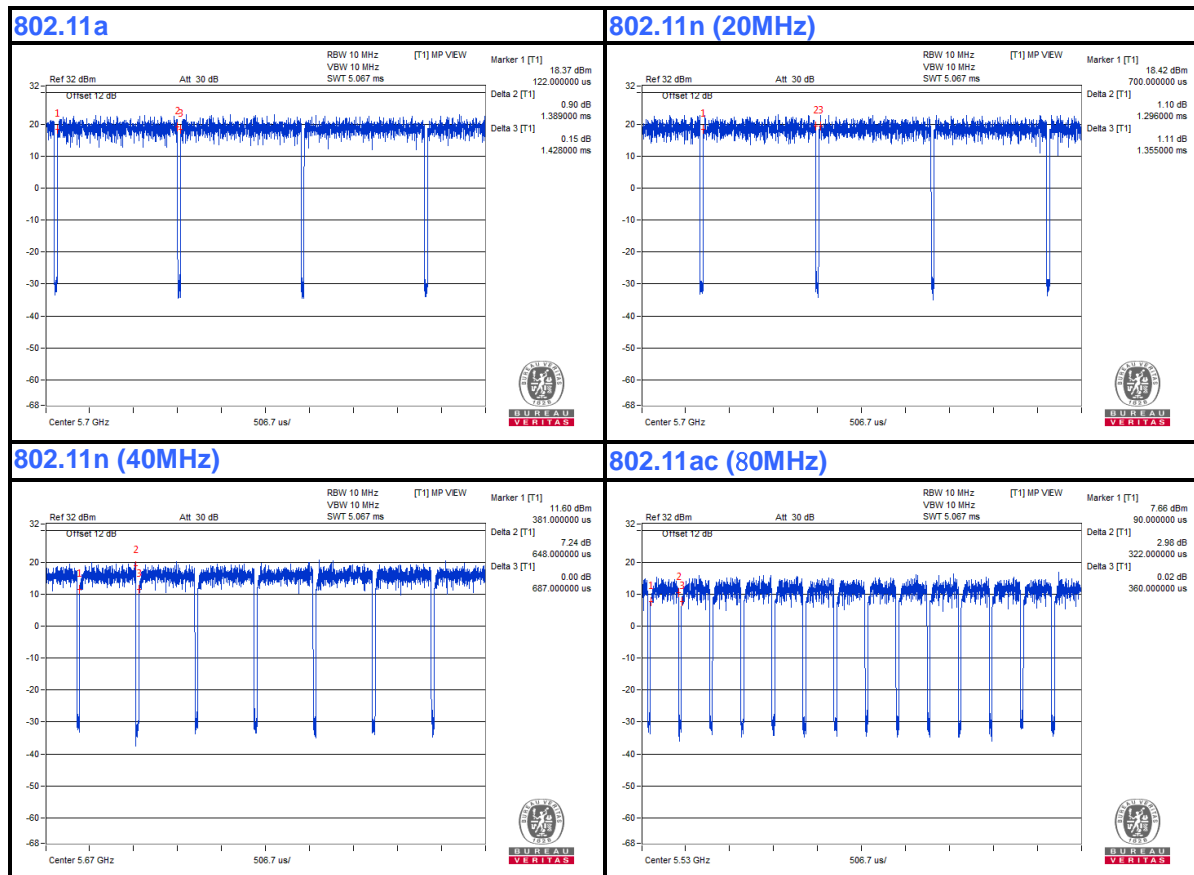



2.4 DESCRIPTION OF SUPPORT UNITS

The EUT has been tested as an independent unit together with other necessary accessories or support units. The following support units or accessories were used to form a representative test configuration during the tests.

NO.	PRODUCT	BRAND	MODEL NO.	SERIAL NO.	FCC ID
1	PC	HP	A6608CN	3CR83825X3	N/A

NO.	SIGNAL CABLE DESCRIPTION OF THE ABOVE SUPPORT UNITS
1	AC Line: Unshielded, Detachable 1.5m

NOTE:

1. All power cords of the above support units are non shielded (1.8m).



2.4.1 CONFIGURATION OF SYSTEM UNDER TEST

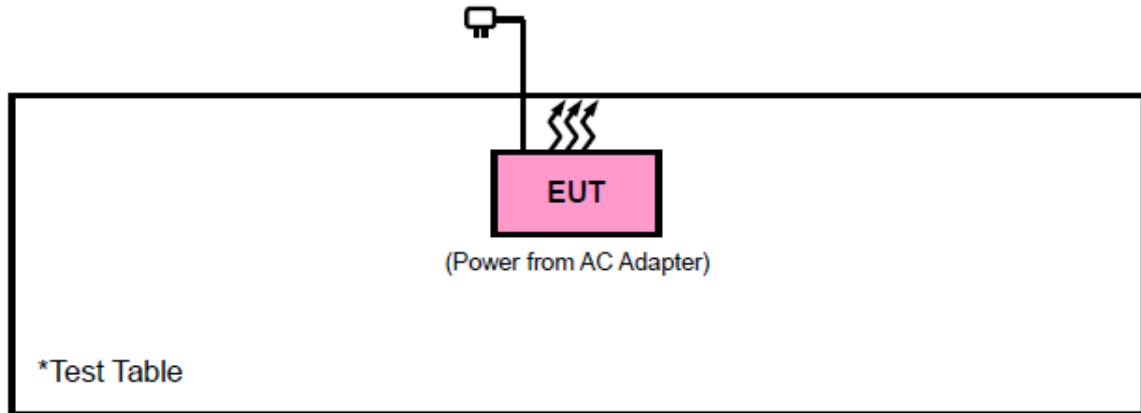

2.5 GENERAL DESCRIPTION OF APPLIED STANDARDS

The EUT is a RF Product. According to the specifications of the manufacturer, it must comply with the requirements of the following standards:

FCC Part 15, Subpart E (15.407)

KDB 789033 D02 General U-NII Test Procedures New Rules v02r01

ANSI C63.10-2013

All test items have been performed and recorded as per the above standards.

NOTE: The EUT is also considered as a kind of computer peripheral, because the connection to computer is necessary for typical use. It has been verified to comply with the requirements of FCC Part 15, Subpart B, Class B (Certification). The test report has been issued separately.



3 TEST TYPES AND RESULTS

3.1 RADIATED EMISSION AND BANDEDGE MEASUREMENT

3.1.1 LIMITS OF RADIATED EMISSION AND BANDEDGE MEASUREMENT

Radiated emissions which fall in the restricted bands must comply with the radiated emission limits specified as below table:

FREQUENCIES (MHz)	FIELD STRENGTH (microvolts/meter)	MEASUREMENT DISTANCE (meters)
0.009 ~ 0.490	2400/F(kHz)	300
0.490 ~ 1.705	24000/F(kHz)	30
1.705 ~ 30.0	30	30
30 ~ 88	100	3
88 ~ 216	150	3
216 ~ 960	200	3
Above 960	500	3

NOTE:

1. The lower limit shall apply at the transition frequencies.
2. Emission level (dBuV/m) = 20 log Emission level (uV/m).
3. For frequencies above 1000MHz, the field strength limits are based on average detector, however, the peak field strength of any emission shall not exceed the maximum permitted average limits, specified above by more than 20dB under any condition of modulation.



3.1.2 LIMITS OF UNWANTED EMISSION

RESTRICTED BANDS	APPLICABLE TO	LIMIT	
	789033 D02 General UNII Test Procedures New Rules v01r04	FIELD STRENGTH AT 3m (dBµV/m)	
		PK : 74	AV : 54
OUT OF THE RESTRICTED BANDS	APPLICABLE TO	EIRP LIMIT (dBm/MHz)	EQUIVALENT FIELD STRENGTH AT 3m (dBµV/m)
	15.407(b)(1)	PK : -27	PK : 68.3
	15.407(b)(2)		
	15.407(b)(3)		
15.407(b)(4)	See note 2 (FCC 16-24)		

NOTE: The following formula is used to convert the equipment isotropic radiated power (eirp) to field strength:

$$E = \frac{1000000\sqrt{30P}}{3} \mu\text{V/m, where P is the eirp (Watts).}$$

2. All emissions shall be limited to a level of -27 dBm/MHz at 75 MHz or more above or below the band edge increasing linearly to 10 dBm/MHz at 25 MHz above or below the band edge, and from 25 MHz above or below the band edge increasing linearly to a level of 15.6 dBm/MHz at 5 MHz above or below the band edge, and from 5 MHz above or below the band edge increasing linearly to a level of 27 dBm/MHz at the band edge.



3.1.3 TEST INSTRUMENTS

Equipment	Manufacturer	Model No.	Serial No.	Last Cal.	Next Cal.
3m Semi-anechoic Chamber	ETS-LINDGREN	9m*6m*6m	Euroshieldpn-CT0001143-1216	Apr. 21,18	Apr. 20,19
Bilog Antenna	ETS-LINDGREN	3143B	00161965	Nov. 26,16	Nov. 25,18
Horn Antenna	ETS-LINDGREN	3117	00168728	Nov. 26,16	Nov. 25,18
Loop antenna	Daze	ZN30900A	0708	Nov. 20,17	Nov. 19,18
Horn Antenna (18GHz-40GHz)	N/A	QWH-SL-18-40-K-SG/QMS-00361	15433	Dec. 16,16	Dec. 15,18
Test Software	E3	V 9.160323	N/A	N/A	N/A
Test Software	ADT	ADT_Radiated_V7.6.15.9.2	N/A	N/A	N/A
10dB Attenuator	JFW/USA	50HF-010-SMA	1505	Jul. 24,17	Jul. 23,18
MXE EMI Receiver	KEYSIGHT	N9038A-544	MY54450026	Mar. 16,18	Mar. 15,19
Signal Pre-Amplifier	EMSI	EMC 9135	980249	Jul. 24,17	Jul. 23,18
Signal Pre-Amplifier	EMSI	EMC 012645B	980257	Jul. 24,17	Jul. 23,18
Signal Pre-Amplifier	EMSI	EMC 184045B	980259	Jul. 24,17	Jul. 23,18

NOTE:

1. The calibration interval of the above test instruments is 12 months and the calibrations are traceable to CEPREI/CHINA, GRGT/CHINA and NIM/CHINA.
2. The test was performed in 3m Chamber.
3. The FCC Site Registration No. is 525120.

3.1.4 TEST PROCEDURES

- a. The EUT was placed on the top of a rotating table 0.8 meters (for below 1GHz) / 1.5 meters (for above 1GHz) above the ground at 3 meter chamber room for test. The table was rotated 360 degrees to determine the position of the highest radiation.
- b. The EUT was set 3 meters away from the interference-receiving antenna, which was mounted on the top of a variable-height antenna tower.
- c. The antenna is a broadband antenna, and its height is varied from one meter to four meters above the ground to determine the maximum value of the field strength. Both horizontal and vertical polarizations of the antenna are set to make the measurement.
- d. For each suspected emission, the EUT was arranged to its worst case and then the antenna was tuned to heights from 1 meter to 4 meters and the rotatable table was turned from 0 degrees to 360 degrees to find the maximum reading.
- e. The test-receiver system was set to Peak Detect Function and Specified Bandwidth with Maximum Hold Mode.
- f. If the emission level of the EUT in peak mode was 10dB lower than the limit specified, then testing could be stopped and the peak values of the EUT would be reported. Otherwise the emissions that did not have 10dB margin would be re-tested one by one using peak, quasi-peak or average method as specified and then reported in a data sheet.

NOTE:

1. The resolution bandwidth and video bandwidth of test receiver/spectrum analyzer is 120kHz for Peak detection (PK) and Quasi-peak detection (QP) at frequency below 1GHz.
2. The resolution bandwidth of test receiver/spectrum analyzer is 1MHz and video bandwidth is 3MHz for Peak detection at frequency above 1GHz.
3. The resolution bandwidth of test receiver/spectrum analyzer is 1MHz and the video bandwidth is 10Hz for Average detection (AV) at frequency above 1GHz.
4. All modes of operation were investigated and the worst-case emissions are reported.

3.1.5 DEVIATION FROM TEST STANDARD

No deviation.



3.1.6 TEST SETUP

< Frequency Range below 30MHz >

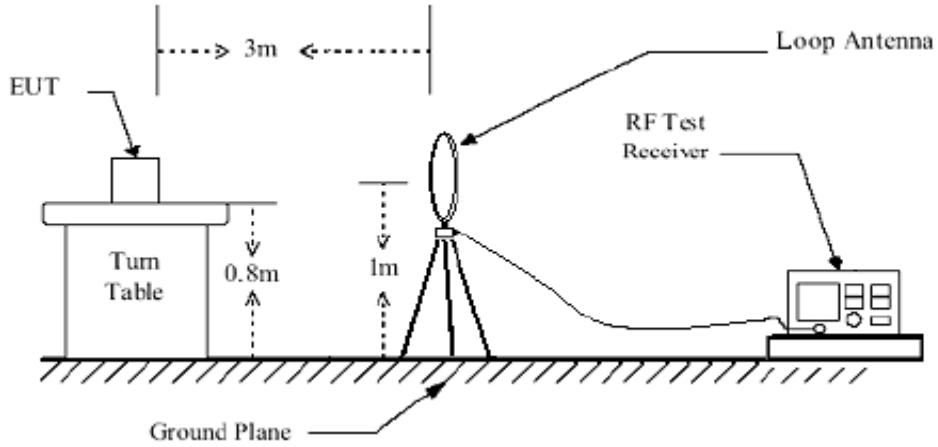

< Frequency Range 30MHz~1GHz >

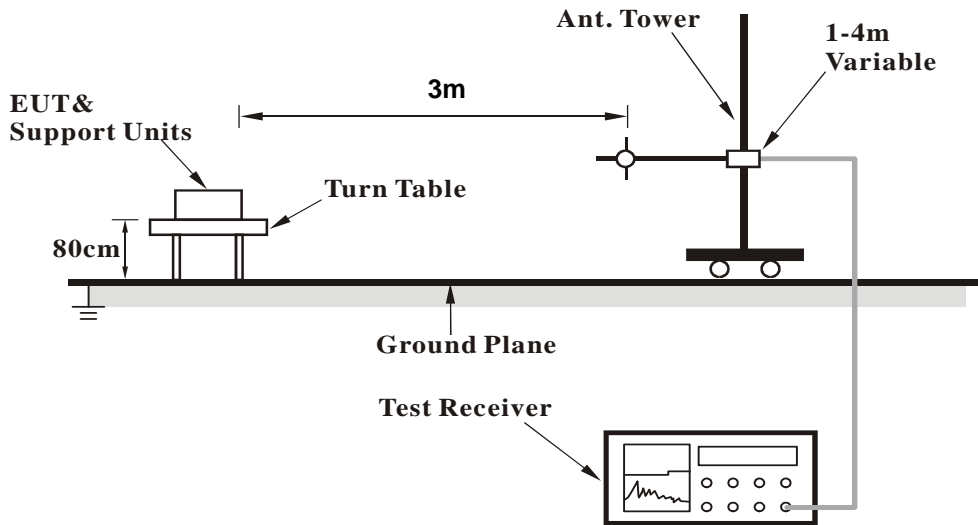



<Frequency Range above 1GHz>

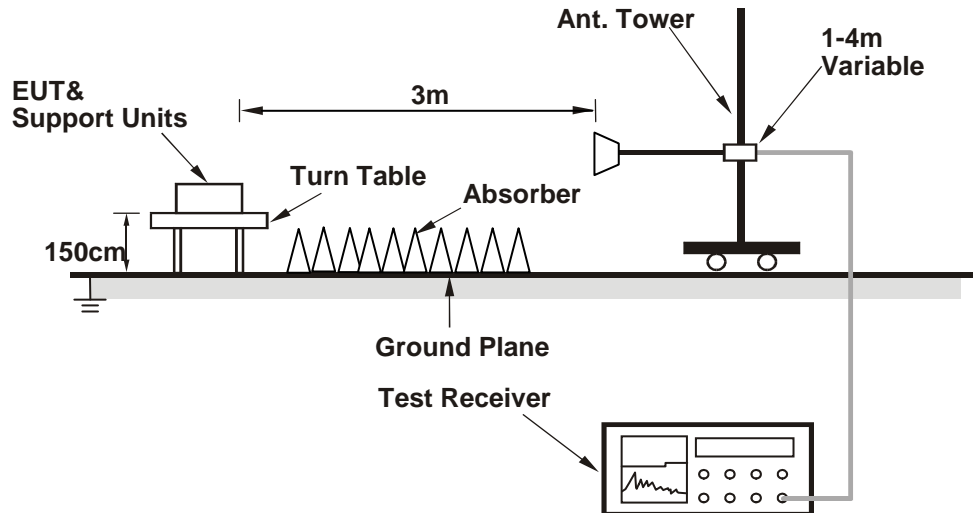

For the actual test configuration, please refer to the attached file (Test Setup Photo).

3.1.7 EUT OPERATING CONDITION

- Set the EUT under full load condition and placed them on a testing table.
- Set the transmitter part of EUT under transmission condition continuously at specific channel frequency.
- The necessary accessories enable the EUT in full functions.



3.1.8 TEST RESULTS

BELOW 1GHz WORST-CASE DATA:

9 KHz – 30 MHz data: the amplitude of spurious emissions attenuated more than 20 dB below the permissible value is not required in the report.

30 MHz – 1GHz data:

802.11n (20MHz)

CHANNEL	TX Channel 140	DETECTOR FUNCTION	Quasi-Peak (QP)
FREQUENCY RANGE	30MHz ~ 1GHz		

ANTENNA POLARITY & TEST DISTANCE: HORIZONTAL AT 3 M										
FREQ. (MHz)	EMISSION LEVEL (dBuV/m)	READ LEVEL (dBuV)	LIMIT (dBuV/m)	MARGIN (dB)	ANTENNA FACTOR (dB /m)	CABLE LOSS (dB)	PREAMP FACTOR (dB)	ANTENNA HEIGHT (cm)	TABLE ANGLE (Degree)	REMARK
58.13	19.06	48.81	40	-20.94	6.42	1.16	37.33	100	248	QP
144.46	29.48	55.91	43.5	-14.02	8.54	1.85	36.82	100	15	QP
235.64	28.19	50.61	46	-17.81	11.74	2.37	36.53	100	31	QP
344.28	23.31	42.14	46	-22.69	14.86	2.91	36.6	100	222	QP
485.9	24.77	40.05	46	-21.23	18.23	3.42	36.93	100	289	QP
666.32	17.69	28.66	46	-28.31	22.16	4.19	37.32	100	321	QP

REMARKS:

1. Emission level (dBuV/m) = Raw Value (dBuV) + Correction Factor (dB/m).
2. Correction Factor (dB/m) = Antenna Factor (dB/m) + Cable Factor (dB).
3. The other emission levels were very low against the limit.
4. Margin value = Emission level – Limit value.

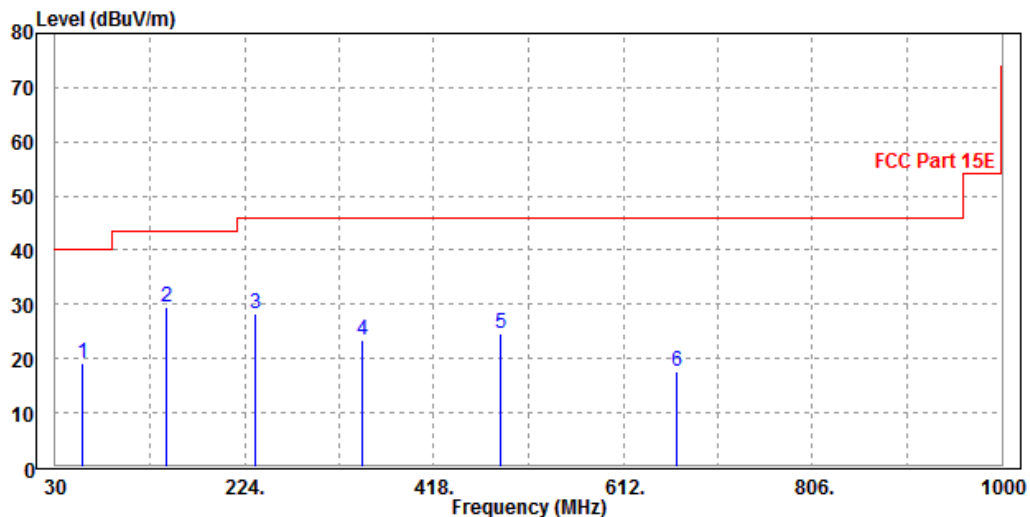



CHANNEL	Channel 140	DETECTOR FUNCTION	Quasi-Peak (QP)
FREQUENCY RANGE	30MHz ~ 1GHz		

ANTENNA POLARITY & TEST DISTANCE: VERTICAL AT 3 M										
FREQ. (MHz)	EMISSION LEVEL (dBuV/m)	READ LEVEL (dBuV)	LIMIT (dBuV/m)	MARGIN (dB)	ANTENNA FACTOR (dB /m)	CABLE LOSS (dB)	PREAMP FACTOR (dB)	ANTENNA HEIGHT (cm)	TABLE ANGLE (Degree)	REMARK
66.86	22.49	51.78	40	-17.51	6.74	1.25	37.28	100	124	QP
144.46	15.3	41.73	43.5	-28.2	8.54	1.85	36.82	100	302	QP
235.64	19.7	42.12	46	-26.3	11.74	2.37	36.53	100	196	QP
340.4	26.1	45.1	46	-19.9	14.7	2.89	36.59	100	269	QP
564.47	24.83	38.55	46	-21.17	19.62	3.81	37.15	100	33	QP
733.25	21.24	31.21	46	-24.76	23.07	4.41	37.45	100	114	QP

REMARKS:

1. Emission level (dBuV/m) = Raw Value (dBuV) + Correction Factor (dB/m).
2. Correction Factor (dB/m) = Antenna Factor (dB/m) + Cable Factor (dB).
3. The other emission levels were very low against the limit.
4. Margin value = Emission level – Limit value.

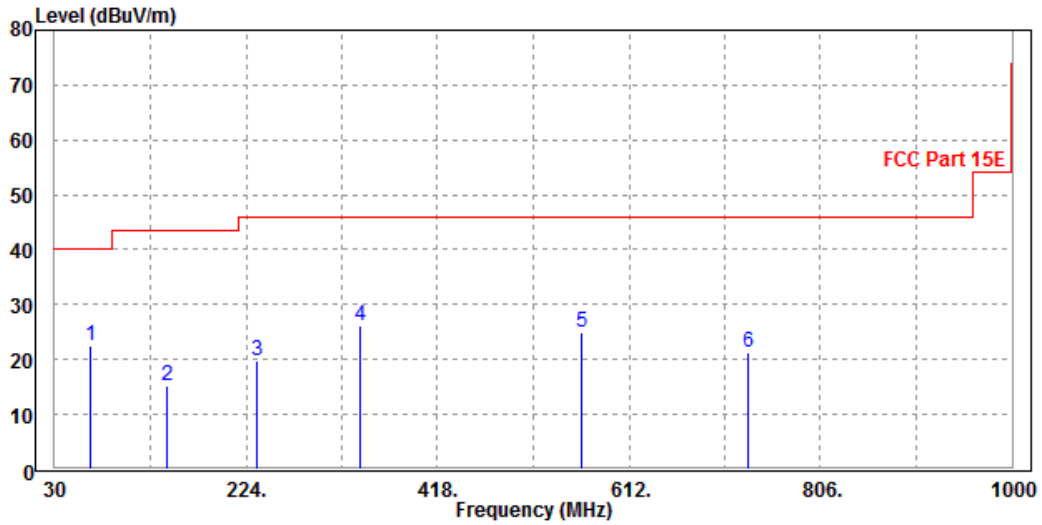



ABOVE 1GHz WORST-CASE DATA:

Note: For higher frequency, the emission is too low to be detected.

Band 1

802.11a

CHANNEL	TX Channel 36	DETECTOR FUNCTION	Peak (PK)
FREQUENCY RANGE	1GHz ~ 40GHz		Average (AV)

ANTENNA POLARITY & TEST DISTANCE: HORIZONTAL AT 3 M										
FREQ. (MHz)	EMISSION LEVEL (dBuV/m)	READ LEVEL (dBuV)	LIMIT (dBuV/m)	MARGIN (dB)	ANTENNA FACTOR (dB /m)	CABLE LOSS (dB)	PREAMP FACTOR (dB)	ANTENNA HEIGHT (cm)	TABLE ANGLE (Degree)	REMARK
5150	49.16	50.69	54	-4.84	37.26	7.42	46.21	110	32	Average
5150	59.03	60.56	74	-14.97	37.26	7.42	46.21	110	32	Peak
5180	84.61	86.13			37.27	7.43	46.22	110	32	Average
5180	90.77	92.29			37.27	7.43	46.22	110	32	Peak
5350	47.61	49.05	54	-6.39	37.34	7.47	46.25	110	32	Average
5350	57.08	58.52	74	-16.92	37.34	7.47	46.25	110	32	Peak
ANTENNA POLARITY & TEST DISTANCE: VERTICAL AT 3 M										
FREQ. (MHz)	EMISSION LEVEL (dBuV/m)	READ LEVEL (dBuV)	LIMIT (dBuV/m)	MARGIN (dB)	ANTENNA FACTOR (dB /m)	CABLE LOSS (dB)	PREAMP FACTOR (dB)	ANTENNA HEIGHT (cm)	TABLE ANGLE (Degree)	REMARK
5150	49.26	50.79	54	-4.74	37.26	7.42	46.21	170	320	Average
5150	59.04	60.57	74	-14.96	37.26	7.42	46.21	170	320	Peak
5180	86.9	88.42			37.27	7.43	46.22	170	320	Average
5180	93.6	95.12			37.27	7.43	46.22	170	320	Peak
5350	47.63	49.07	54	-6.37	37.34	7.47	46.25	170	320	Average
5350	56.83	58.27	74	-17.17	37.34	7.47	46.25	170	320	Peak

REMARKS:

- Emission Level = Read Level+ Antenna Factor + Cable Loss- Preamp Factor
Margin value = Emission level – Limit value.
- 5180MHz: Fundamental frequency.



CHANNEL	TX Channel 40	DETECTOR FUNCTION	Peak (PK)
FREQUENCY RANGE	1GHz ~ 40GHz		Average (AV)

ANTENNA POLARITY & TEST DISTANCE: HORIZONTAL AT 3 M										
FREQ. (MHz)	EMISSION LEVEL (dBuV/m)	READ LEVEL (dBuV)	LIMIT (dBuV/m)	MARGIN (dB)	ANTENNA FACTOR (dB /m)	CABLE LOSS (dB)	PREAMP FACTOR (dB)	ANTENNA HEIGHT (cm)	TABLE ANGLE (Degree)	REMARK
5150	49.05	50.58	54	-4.95	37.26	7.42	46.21	200	67	Average
5150	59.04	60.57	74	-14.96	37.26	7.42	46.21	200	67	Peak
5200	91.71	93.22			37.28	7.43	46.22	200	67	Average
5200	97.95	99.46			37.28	7.43	46.22	200	67	Peak
5350	47.67	49.11	54	-6.33	37.34	7.47	46.25	200	67	Average
5350	57.95	59.39	74	-16.05	37.34	7.47	46.25	200	67	Peak

ANTENNA POLARITY & TEST DISTANCE: VERTICAL AT 3 M										
FREQ. (MHz)	EMISSION LEVEL (dBuV/m)	READ LEVEL (dBuV)	LIMIT (dBuV/m)	MARGIN (dB)	ANTENNA FACTOR (dB /m)	CABLE LOSS (dB)	PREAMP FACTOR (dB)	ANTENNA HEIGHT (cm)	TABLE ANGLE (Degree)	REMARK
5150	49.15	50.68	54	-4.85	37.26	7.42	46.21	200	65	Average
5150	58.79	60.32	74	-15.21	37.26	7.42	46.21	200	65	Peak
5200	92.36	93.87			37.28	7.43	46.22	200	65	Average
5200	99.77	101.28			37.28	7.43	46.22	200	65	Peak
5350	47.75	49.19	54	-6.25	37.34	7.47	46.25	200	65	Average
5350	57.42	58.86	74	-16.58	37.34	7.47	46.25	200	65	Peak

REMARKS:

- Emission Level = Read Level+ Antenna Factor + Cable Loss- Preamp Factor
Margin value = Emission level – Limit value.
- 5200MHz: Fundamental frequency.



CHANNEL	TX Channel 48	DETECTOR FUNCTION	Peak (PK)
FREQUENCY RANGE	1GHz ~ 40GHz		Average (AV)

ANTENNA POLARITY & TEST DISTANCE: HORIZONTAL AT 3 M										
FREQ. (MHz)	EMISSION LEVEL (dBuV/m)	READ LEVEL (dBuV)	LIMIT (dBuV/m)	MARGIN (dB)	ANTENNA FACTOR (dB /m)	CABLE LOSS (dB)	PREAMP FACTOR (dB)	ANTENNA HEIGHT (cm)	TABLE ANGLE (Degree)	REMARK
5150	49.16	50.69	54	-4.84	37.26	7.42	46.21	100	78	Average
5150	59.1	60.63	74	-14.9	37.26	7.42	46.21	100	78	Peak
5240	91.98	93.47			37.3	7.44	46.23	100	78	Average
5240	101.13	102.62			37.3	7.44	46.23	100	78	Peak
5350	47.87	49.31	54	-6.13	37.34	7.47	46.25	100	78	Average
5350	57.24	58.68	74	-16.76	37.34	7.47	46.25	100	78	Peak

ANTENNA POLARITY & TEST DISTANCE: VERTICAL AT 3 M										
FREQ. (MHz)	EMISSION LEVEL (dBuV/m)	READ LEVEL (dBuV)	LIMIT (dBuV/m)	MARGIN (dB)	ANTENNA FACTOR (dB /m)	CABLE LOSS (dB)	PREAMP FACTOR (dB)	ANTENNA HEIGHT (cm)	TABLE ANGLE (Degree)	REMARK
5150	49.13	50.66	54	-4.87	37.26	7.42	46.21	200	120	Average
5150	59.79	61.32	74	-14.21	37.26	7.42	46.21	200	120	Peak
5240	93.7	95.19			37.3	7.44	46.23	200	120	Average
5240	101.15	102.64			37.3	7.44	46.23	200	120	Peak
5350	47.84	49.28	54	-6.16	37.34	7.47	46.25	200	120	Average
5350	59.3	60.74	74	-14.7	37.34	7.47	46.25	200	120	Peak

REMARKS:

- Emission Level = Read Level+ Antenna Factor + Cable Loss- Preamp Factor
Margin value = Emission level – Limit value.
- 5240MHz: Fundamental frequency.



802.11n (20MHz)

CHANNEL	TX Channel 36	DETECTOR FUNCTION	Peak (PK)
FREQUENCY RANGE	1GHz ~ 40GHz		Average (AV)

ANTENNA POLARITY & TEST DISTANCE: HORIZONTAL AT 3 M										
FREQ. (MHz)	EMISSION LEVEL (dBuV/m)	READ LEVEL (dBuV)	LIMIT (dBuV/m)	MARGIN (dB)	ANTENNA FACTOR (dB /m)	CABLE LOSS (dB)	PREAMP FACTOR (dB)	ANTENNA HEIGHT (cm)	TABLE ANGLE (Degree)	REMARK
5150	49.25	50.78	54	-4.75	37.26	7.42	46.21	170	300	Average
5150	58.68	60.21	74	-15.32	37.26	7.42	46.21	170	300	Peak
5180	85.84	87.36			37.27	7.43	46.22	170	300	Average
5180	92.52	94.04			37.27	7.43	46.22	170	300	Peak
5350	47.61	49.05	54	-6.39	37.34	7.47	46.25	170	300	Average
5350	57.22	58.66	74	-16.78	37.34	7.47	46.25	170	300	Peak

ANTENNA POLARITY & TEST DISTANCE: VERTICAL AT 3 M										
FREQ. (MHz)	EMISSION LEVEL (dBuV/m)	READ LEVEL (dBuV)	LIMIT (dBuV/m)	MARGIN (dB)	ANTENNA FACTOR (dB /m)	CABLE LOSS (dB)	PREAMP FACTOR (dB)	ANTENNA HEIGHT (cm)	TABLE ANGLE (Degree)	REMARK
5150	49.41	50.94	54	-4.59	37.26	7.42	46.21	110	40	Average
5150	59.31	60.84	74	-14.69	37.26	7.42	46.21	110	40	Peak
5180	86.4	87.92			37.27	7.43	46.22	110	40	Average
5180	94.36	95.88			37.27	7.43	46.22	110	40	Peak
5350	47.73	49.17	54	-6.27	37.34	7.47	46.25	110	40	Average
5350	57.13	58.57	74	-16.87	37.34	7.47	46.25	110	40	Peak

REMARKS:

- Emission Level = Read Level+ Antenna Factor + Cable Loss- Preamp Factor
Margin value = Emission level – Limit value.
- 5180MHz: Fundamental frequency.



CHANNEL	TX Channel 40	DETECTOR FUNCTION	Peak (PK)
FREQUENCY RANGE	1GHz ~ 40GHz		Average (AV)

ANTENNA POLARITY & TEST DISTANCE: HORIZONTAL AT 3 M										
FREQ. (MHz)	EMISSION LEVEL (dBuV/m)	READ LEVEL (dBuV)	LIMIT (dBuV/m)	MARGIN (dB)	ANTENNA FACTOR (dB /m)	CABLE LOSS (dB)	PREAMP FACTOR (dB)	ANTENNA HEIGHT (cm)	TABLE ANGLE (Degree)	REMARK
5150	49.18	50.71	54	-4.82	37.26	7.42	46.21	160	70	Average
5150	59	60.53	74	-15	37.26	7.42	46.21	160	70	Peak
5200	89.7	91.21			37.28	7.43	46.22	160	70	Average
5200	95.98	97.49			37.28	7.43	46.22	160	70	Peak
5350	47.79	49.23	54	-6.21	37.34	7.47	46.25	160	70	Average
5350	57.71	59.15	74	-16.29	37.34	7.47	46.25	160	70	Peak

ANTENNA POLARITY & TEST DISTANCE: VERTICAL AT 3 M										
FREQ. (MHz)	EMISSION LEVEL (dBuV/m)	READ LEVEL (dBuV)	LIMIT (dBuV/m)	MARGIN (dB)	ANTENNA FACTOR (dB /m)	CABLE LOSS (dB)	PREAMP FACTOR (dB)	ANTENNA HEIGHT (cm)	TABLE ANGLE (Degree)	REMARK
5150	49.18	50.71	54	-4.82	37.26	7.42	46.21	180	70	Average
5150	59.22	60.75	74	-14.78	37.26	7.42	46.21	180	70	Peak
5200	90.18	91.69			37.28	7.43	46.22	180	70	Average
5200	96.88	98.39			37.28	7.43	46.22	180	70	Peak
5350	47.77	49.21	54	-6.23	37.34	7.47	46.25	180	70	Average
5350	57.6	59.04	74	-16.4	37.34	7.47	46.25	180	70	Peak

REMARKS:

1. Emission Level = Read Level+ Antenna Factor + Cable Loss- Preamp Factor
Margin value = Emission level – Limit value.
2. 5200MHz: Fundamental frequency.



CHANNEL	TX Channel 48	DETECTOR FUNCTION	Peak (PK)
FREQUENCY RANGE	1GHz ~ 40GHz		Average (AV)

ANTENNA POLARITY & TEST DISTANCE: HORIZONTAL AT 3 M										
FREQ. (MHz)	EMISSION LEVEL (dBuV/m)	READ LEVEL (dBuV)	LIMIT (dBuV/m)	MARGIN (dB)	ANTENNA FACTOR (dB /m)	CABLE LOSS (dB)	PREAMP FACTOR (dB)	ANTENNA HEIGHT (cm)	TABLE ANGLE (Degree)	REMARK
5150	49.21	50.74	54	-4.79	37.26	7.42	46.21	100	80	Average
5150	58.95	60.48	74	-15.05	37.26	7.42	46.21	100	80	Peak
5240	90.03	91.52			37.3	7.44	46.23	100	80	Average
5240	96.65	98.14			37.3	7.44	46.23	100	80	Peak
5350	47.81	49.25	54	-6.19	37.34	7.47	46.25	100	80	Average
5350	58.04	59.48	74	-15.96	37.34	7.47	46.25	100	80	Peak

ANTENNA POLARITY & TEST DISTANCE: VERTICAL AT 3 M										
FREQ. (MHz)	EMISSION LEVEL (dBuV/m)	READ LEVEL (dBuV)	LIMIT (dBuV/m)	MARGIN (dB)	ANTENNA FACTOR (dB /m)	CABLE LOSS (dB)	PREAMP FACTOR (dB)	ANTENNA HEIGHT (cm)	TABLE ANGLE (Degree)	REMARK
5150	49.18	50.71	54	-4.82	37.26	7.42	46.21	200	100	Average
5150	58.85	60.38	74	-15.15	37.26	7.42	46.21	200	100	Peak
5240	93.46	94.95			37.3	7.44	46.23	200	100	Average
5240	99.87	101.36			37.3	7.44	46.23	200	100	Peak
5350	47.91	49.35	54	-6.09	37.34	7.47	46.25	200	100	Average
5350	58.47	59.91	74	-15.53	37.34	7.47	46.25	200	100	Peak

REMARKS:

- Emission Level = Read Level+ Antenna Factor + Cable Loss- Preamp Factor
Margin value = Emission level – Limit value.
- 5240MHz: Fundamental frequency.



802.11n (40MHz)

CHANNEL	TX Channel 38	DETECTOR FUNCTION	Peak (PK)
FREQUENCY RANGE	1GHz ~ 40GHz		Average (AV)

ANTENNA POLARITY & TEST DISTANCE: HORIZONTAL AT 3 M										
FREQ. (MHz)	EMISSION LEVEL (dBuV/m)	READ LEVEL (dBuV)	LIMIT (dBuV/m)	MARGIN (dB)	ANTENNA FACTOR (dB /m)	CABLE LOSS (dB)	PREAMP FACTOR (dB)	ANTENNA HEIGHT (cm)	TABLE ANGLE (Degree)	REMARK
5150	50.44	51.97	54	-3.56	37.26	7.42	46.21	110	70	Average
5150	61.21	62.74	74	-12.79	37.26	7.42	46.21	110	70	Peak
5190	90.16	91.67			37.28	7.43	46.22	110	70	Average
5190	96.91	98.42			37.28	7.43	46.22	110	70	Peak
5350	47.88	49.32	54	-6.12	37.34	7.47	46.25	110	70	Average
5350	57.87	59.31	74	-16.13	37.34	7.47	46.25	110	70	Peak

ANTENNA POLARITY & TEST DISTANCE: VERTICAL AT 3 M										
FREQ. (MHz)	EMISSION LEVEL (dBuV/m)	READ LEVEL (dBuV)	LIMIT (dBuV/m)	MARGIN (dB)	ANTENNA FACTOR (dB /m)	CABLE LOSS (dB)	PREAMP FACTOR (dB)	ANTENNA HEIGHT (cm)	TABLE ANGLE (Degree)	REMARK
5150	50.44	51.97	54	-3.56	37.26	7.42	46.21	200	110	Average
5150	63.36	64.89	74	-10.64	37.26	7.42	46.21	200	110	Peak
5190	91.01	92.52			37.28	7.43	46.22	200	110	Average
5190	98	99.51			37.28	7.43	46.22	200	110	Peak
5350	47.87	49.31	54	-6.13	37.34	7.47	46.25	200	110	Average
5350	58.22	59.66	74	-15.78	37.34	7.47	46.25	200	110	Peak

REMARKS:

- Emission Level = Read Level+ Antenna Factor + Cable Loss- Preamp Factor
Margin value = Emission level – Limit value.
- 5190MHz: Fundamental frequency.



CHANNEL	TX Channel 46	DETECTOR FUNCTION	Peak (PK)
FREQUENCY RANGE	1GHz ~ 40GHz		Average (AV)

ANTENNA POLARITY & TEST DISTANCE: HORIZONTAL AT 3 M										
FREQ. (MHz)	EMISSION LEVEL (dBuV/m)	READ LEVEL (dBuV)	LIMIT (dBuV/m)	MARGIN (dB)	ANTENNA FACTOR (dB /m)	CABLE LOSS (dB)	PREAMP FACTOR (dB)	ANTENNA HEIGHT (cm)	TABLE ANGLE (Degree)	REMARK
5150	49.11	50.64	54	-4.89	37.26	7.42	46.21	110	70	Average
5150	59.81	61.34	74	-14.19	37.26	7.42	46.21	110	70	Peak
5230	90.27	91.77			37.29	7.44	46.23	110	70	Average
5230	97.32	98.82			37.29	7.44	46.23	110	70	Peak
5350	48.11	49.55	54	-5.89	37.34	7.47	46.25	110	70	Average
5350	55.92	57.36	74	-18.08	37.34	7.47	46.25	110	70	Peak

ANTENNA POLARITY & TEST DISTANCE: VERTICAL AT 3 M										
FREQ. (MHz)	EMISSION LEVEL (dBuV/m)	READ LEVEL (dBuV)	LIMIT (dBuV/m)	MARGIN (dB)	ANTENNA FACTOR (dB /m)	CABLE LOSS (dB)	PREAMP FACTOR (dB)	ANTENNA HEIGHT (cm)	TABLE ANGLE (Degree)	REMARK
5150	49.23	50.76	54	-4.77	37.26	7.42	46.21	200	110	Average
5150	58.75	60.28	74	-15.25	37.26	7.42	46.21	200	110	Peak
5230	97.4	98.9			37.29	7.44	46.23	200	110	Average
5230	104.5	106			37.29	7.44	46.23	200	110	Peak
5350	47.92	49.36	54	-6.08	37.34	7.47	46.25	200	110	Average
5350	57.79	59.23	74	-16.21	37.34	7.47	46.25	200	110	Peak

REMARKS:

- Emission Level = Read Level+ Antenna Factor + Cable Loss- Preamp Factor
Margin value = Emission level – Limit value.
- 5230MHz: Fundamental frequency.



802.11ac (80MHz)

CHANNEL	TX Channel 42	DETECTOR FUNCTION	Peak (PK)
FREQUENCY RANGE	1GHz ~ 40GHz		Average (AV)

ANTENNA POLARITY & TEST DISTANCE: HORIZONTAL AT 3 M										
FREQ. (MHz)	EMISSION LEVEL (dBuV/m)	READ LEVEL (dBuV)	LIMIT (dBuV/m)	MARGIN (dB)	ANTENNA FACTOR (dB /m)	CABLE LOSS (dB)	PREAMP FACTOR (dB)	ANTENNA HEIGHT (cm)	TABLE ANGLE (Degree)	REMARK
5150	51.02	52.55	54	-2.98	37.26	7.42	46.21	100	60	Average
5150	61.33	62.86	74	-12.67	37.26	7.42	46.21	100	60	Peak
5210	81.96	83.46			37.28	7.44	46.22	100	60	Average
5210	93.59	95.09			37.28	7.44	46.22	100	60	Peak
5350	47.87	49.31	54	-6.13	37.34	7.47	46.25	100	60	Average
5350	59.52	60.96	74	-14.48	37.34	7.47	46.25	100	60	Peak

ANTENNA POLARITY & TEST DISTANCE: VERTICAL AT 3 M										
FREQ. (MHz)	EMISSION LEVEL (dBuV/m)	READ LEVEL (dBuV)	LIMIT (dBuV/m)	MARGIN (dB)	ANTENNA FACTOR (dB /m)	CABLE LOSS (dB)	PREAMP FACTOR (dB)	ANTENNA HEIGHT (cm)	TABLE ANGLE (Degree)	REMARK
5150	50.82	52.35	54	-3.18	37.26	7.42	46.21	200	91	Average
5150	63.75	65.28	74	-10.25	37.26	7.42	46.21	200	91	Peak
5210	86.45	87.95			37.28	7.44	46.22	200	91	Average
5210	93.26	94.76			37.28	7.44	46.22	200	91	Peak
5350	48.18	49.62	54	-5.82	37.34	7.47	46.25	200	91	Average
5350	57.5	58.94	74	-16.5	37.34	7.47	46.25	200	91	Peak

REMARKS:

- Emission Level = Read Level+ Antenna Factor + Cable Loss- Preamp Factor
Margin value = Emission level – Limit value.
- 5210MHz: Fundamental frequency.



Band 2
802.11a

CHANNEL	TX Channel 52	DETECTOR FUNCTION	Peak (PK)
FREQUENCY RANGE	1GHz ~ 40GHz		Average (AV)

ANTENNA POLARITY & TEST DISTANCE: HORIZONTAL AT 3 M										
FREQ. (MHz)	EMISSION LEVEL (dBuV/m)	READ LEVEL (dBuV)	LIMIT (dBuV/m)	MARGIN (dB)	ANTENNA FACTOR (dB /m)	CABLE LOSS (dB)	PREAMP FACTOR (dB)	ANTENNA HEIGHT (cm)	TABLE ANGLE (Degree)	REMARK
5150	49.18	50.71	54	-4.82	37.26	7.42	46.21	120	80	Average
5150	58.88	60.41	74	-15.12	37.26	7.42	46.21	120	80	Peak
5260	91.19	92.67			37.3	7.45	46.23	120	80	Average
5260	100.1	101.58			37.3	7.45	46.23	120	80	Peak
5350	47.28	48.72	54	-6.72	37.34	7.47	46.25	120	80	Average
5350	59.72	61.16	74	-14.28	37.34	7.47	46.25	120	80	Peak
ANTENNA POLARITY & TEST DISTANCE: VERTICAL AT 3 M										
FREQ. (MHz)	EMISSION LEVEL (dBuV/m)	READ LEVEL (dBuV)	LIMIT (dBuV/m)	MARGIN (dB)	ANTENNA FACTOR (dB /m)	CABLE LOSS (dB)	PREAMP FACTOR (dB)	ANTENNA HEIGHT (cm)	TABLE ANGLE (Degree)	REMARK
5150	49.18	50.71	54	-4.82	37.26	7.42	46.21	100	120	Average
5150	59.53	61.06	74	-14.47	37.26	7.42	46.21	100	120	Peak
5260	89.97	91.45			37.3	7.45	46.23	100	120	Average
5260	98.25	99.73			37.3	7.45	46.23	100	120	Peak
5350	48.11	49.55	54	-5.89	37.34	7.47	46.25	100	120	Average
5350	55.27	56.71	74	-18.73	37.34	7.47	46.25	100	120	Peak

REMARKS:

- Emission Level = Read Level+ Antenna Factor + Cable Loss- Preamp Factor
Margin value = Emission level – Limit value.
- 5260MHz: Fundamental frequency.



CHANNEL	TX Channel 60	DETECTOR FUNCTION	Peak (PK)
FREQUENCY RANGE	1GHz ~ 40GHz		Average (AV)

ANTENNA POLARITY & TEST DISTANCE: HORIZONTAL AT 3 M										
FREQ. (MHz)	EMISSION LEVEL (dBuV/m)	READ LEVEL (dBuV)	LIMIT (dBuV/m)	MARGIN (dB)	ANTENNA FACTOR (dB /m)	CABLE LOSS (dB)	PREAMP FACTOR (dB)	ANTENNA HEIGHT (cm)	TABLE ANGLE (Degree)	REMARK
5150	49.18	50.71	54	-4.82	37.26	7.42	46.21	120	70	Average
5150	59.11	60.64	74	-14.89	37.26	7.42	46.21	120	70	Peak
5300	92.71	94.17			37.32	7.46	46.24	120	70	Average
5300	101.15	102.61			37.32	7.46	46.24	120	70	Peak
5350	47.35	48.79	54	-6.65	37.34	7.47	46.25	120	70	Average
5350	57.17	58.61	74	-16.83	37.34	7.47	46.25	120	70	Peak

ANTENNA POLARITY & TEST DISTANCE: VERTICAL AT 3 M										
FREQ. (MHz)	EMISSION LEVEL (dBuV/m)	READ LEVEL (dBuV)	LIMIT (dBuV/m)	MARGIN (dB)	ANTENNA FACTOR (dB /m)	CABLE LOSS (dB)	PREAMP FACTOR (dB)	ANTENNA HEIGHT (cm)	TABLE ANGLE (Degree)	REMARK
5150	49.16	50.69	54	-4.84	37.26	7.42	46.21	110	90	Average
5150	58.9	60.43	74	-15.1	37.26	7.42	46.21	110	90	Peak
5300	88.8	90.26			37.32	7.46	46.24	110	90	Average
5300	99.09	100.55			37.32	7.46	46.24	110	90	Peak
5350	48.61	50.05	54	-5.39	37.34	7.47	46.25	110	90	Average
5350	56.13	57.57	74	-17.87	37.34	7.47	46.25	110	90	Peak

REMARKS:

- Emission Level = Read Level+ Antenna Factor + Cable Loss- Preamp Factor
Margin value = Emission level – Limit value.
- 5300MHz: Fundamental frequency.



CHANNEL	TX Channel 64	DETECTOR FUNCTION	Peak (PK)
FREQUENCY RANGE	1GHz ~ 40GHz		Average (AV)

ANTENNA POLARITY & TEST DISTANCE: HORIZONTAL AT 3 M										
FREQ. (MHz)	EMISSION LEVEL (dBuV/m)	READ LEVEL (dBuV)	LIMIT (dBuV/m)	MARGIN (dB)	ANTENNA FACTOR (dB /m)	CABLE LOSS (dB)	PREAMP FACTOR (dB)	ANTENNA HEIGHT (cm)	TABLE ANGLE (Degree)	REMARK
5150	49.15	50.68	54	-4.85	37.26	7.42	46.21	100	65	Average
5150	58.82	60.35	74	-15.18	37.26	7.42	46.21	100	65	Peak
5320	91.95	93.4			37.33	7.46	46.24	100	65	Average
5320	100.87	102.32			37.33	7.46	46.24	100	65	Peak
5350	48.5	49.94	54	-5.5	37.34	7.47	46.25	100	65	Average
5350	57.87	59.31	74	-16.13	37.34	7.47	46.25	100	65	Peak

ANTENNA POLARITY & TEST DISTANCE: VERTICAL AT 3 M										
FREQ. (MHz)	EMISSION LEVEL (dBuV/m)	READ LEVEL (dBuV)	LIMIT (dBuV/m)	MARGIN (dB)	ANTENNA FACTOR (dB /m)	CABLE LOSS (dB)	PREAMP FACTOR (dB)	ANTENNA HEIGHT (cm)	TABLE ANGLE (Degree)	REMARK
5150	49.16	50.69	54	-4.84	37.26	7.42	46.21	200	110	Average
5150	58.55	60.08	74	-15.45	37.26	7.42	46.21	200	110	Peak
5320	93.96	95.41			37.33	7.46	46.24	200	110	Average
5320	100.91	102.36			37.33	7.46	46.24	200	110	Peak
5350	48.68	50.12	54	-5.32	37.34	7.47	46.25	200	110	Average
5350	57.37	58.81	74	-16.63	37.34	7.47	46.25	200	110	Peak

REMARKS:

- Emission Level = Read Level+ Antenna Factor + Cable Loss- Preamp Factor
Margin value = Emission level – Limit value.
- 5320MHz: Fundamental frequency.



802.11n (20MHz)

CHANNEL	TX Channel 52	DETECTOR FUNCTION	Peak (PK)
FREQUENCY RANGE	1GHz ~ 40GHz		Average (AV)

ANTENNA POLARITY & TEST DISTANCE: HORIZONTAL AT 3 M										
FREQ. (MHz)	EMISSION LEVEL (dBuV/m)	READ LEVEL (dBuV)	LIMIT (dBuV/m)	MARGIN (dB)	ANTENNA FACTOR (dB /m)	CABLE LOSS (dB)	PREAMP FACTOR (dB)	ANTENNA HEIGHT (cm)	TABLE ANGLE (Degree)	REMARK
5150	49.19	50.72	54	-4.81	37.26	7.42	46.21	120	70	Average
5150	58.59	60.12	74	-15.41	37.26	7.42	46.21	120	70	Peak
5260	91.21	92.69			37.3	7.45	46.23	120	70	Average
5260	97.7	99.18			37.3	7.45	46.23	120	70	Peak
5350	47.84	49.28	54	-6.16	37.34	7.47	46.25	120	70	Average
5350	57.81	59.25	74	-16.19	37.34	7.47	46.25	120	70	Peak

ANTENNA POLARITY & TEST DISTANCE: VERTICAL AT 3 M										
FREQ. (MHz)	EMISSION LEVEL (dBuV/m)	READ LEVEL (dBuV)	LIMIT (dBuV/m)	MARGIN (dB)	ANTENNA FACTOR (dB /m)	CABLE LOSS (dB)	PREAMP FACTOR (dB)	ANTENNA HEIGHT (cm)	TABLE ANGLE (Degree)	REMARK
5150	49.18	50.71	54	-4.82	37.26	7.42	46.21	100	110	Average
5150	58.07	59.6	74	-15.93	37.26	7.42	46.21	100	110	Peak
5260	89.74	91.22			37.3	7.45	46.23	100	110	Average
5260	97.53	99.01			37.3	7.45	46.23	100	110	Peak
5350	47.89	49.33	54	-6.11	37.34	7.47	46.25	100	110	Average
5350	58.21	59.65	74	-15.79	37.34	7.47	46.25	100	110	Peak

REMARKS:

- Emission Level = Read Level+ Antenna Factor + Cable Loss- Preamp Factor
Margin value = Emission level – Limit value.
- 5260MHz: Fundamental frequency.



CHANNEL	TX Channel 60	DETECTOR FUNCTION	Peak (PK)
FREQUENCY RANGE	1GHz ~ 40GHz		Average (AV)

ANTENNA POLARITY & TEST DISTANCE: HORIZONTAL AT 3 M										
FREQ. (MHz)	EMISSION LEVEL (dBuV/m)	READ LEVEL (dBuV)	LIMIT (dBuV/m)	MARGIN (dB)	ANTENNA FACTOR (dB /m)	CABLE LOSS (dB)	PREAMP FACTOR (dB)	ANTENNA HEIGHT (cm)	TABLE ANGLE (Degree)	REMARK
5150	49.28	50.81	54	-4.72	37.26	7.42	46.21	100	70	Average
5150	59.69	61.22	74	-14.31	37.26	7.42	46.21	100	70	Peak
5300	92.02	93.48			37.32	7.46	46.24	100	70	Average
5300	98.79	100.25			37.32	7.46	46.24	100	70	Peak
5350	48.02	49.46	54	-5.98	37.34	7.47	46.25	100	70	Average
5350	57.07	58.51	74	-16.93	37.34	7.47	46.25	100	70	Peak

ANTENNA POLARITY & TEST DISTANCE: VERTICAL AT 3 M										
FREQ. (MHz)	EMISSION LEVEL (dBuV/m)	READ LEVEL (dBuV)	LIMIT (dBuV/m)	MARGIN (dB)	ANTENNA FACTOR (dB /m)	CABLE LOSS (dB)	PREAMP FACTOR (dB)	ANTENNA HEIGHT (cm)	TABLE ANGLE (Degree)	REMARK
5150	49.22	50.75	54	-4.78	37.26	7.42	46.21	110	100	Average
5150	59.66	61.19	74	-14.34	37.26	7.42	46.21	110	100	Peak
5300	89.58	91.04			37.32	7.46	46.24	110	100	Average
5300	96.23	97.69			37.32	7.46	46.24	110	100	Peak
5350	47.88	49.32	54	-6.12	37.34	7.47	46.25	110	100	Average
5350	58.15	59.59	74	-15.85	37.34	7.47	46.25	110	100	Peak

REMARKS:

- Emission Level = Read Level+ Antenna Factor + Cable Loss- Preamp Factor
Margin value = Emission level – Limit value.
- 5300MHz: Fundamental frequency.



CHANNEL	TX Channel 64	DETECTOR FUNCTION	Peak (PK)
FREQUENCY RANGE	1GHz ~ 40GHz		Average (AV)

ANTENNA POLARITY & TEST DISTANCE: HORIZONTAL AT 3 M

FREQ. (MHz)	EMISSION LEVEL (dBuV/m)	READ LEVEL (dBuV)	LIMIT (dBuV/m)	MARGIN (dB)	ANTENNA FACTOR (dB /m)	CABLE LOSS (dB)	PREAMP FACTOR (dB)	ANTENNA HEIGHT (cm)	TABLE ANGLE (Degree)	REMARK
5150	49.23	50.76	54	-4.77	37.26	7.42	46.21	100	80	Average
5150	59.05	60.58	74	-14.95	37.26	7.42	46.21	100	80	Peak
5320	91.18	92.63			37.33	7.46	46.24	100	80	Average
5320	97.55	99			37.33	7.46	46.24	100	80	Peak
5350	48.53	49.97	54	-5.47	37.34	7.47	46.25	100	80	Average
5350	59.51	60.95	74	-14.49	37.34	7.47	46.25	100	80	Peak

ANTENNA POLARITY & TEST DISTANCE: VERTICAL AT 3 M

FREQ. (MHz)	EMISSION LEVEL (dBuV/m)	READ LEVEL (dBuV)	LIMIT (dBuV/m)	MARGIN (dB)	ANTENNA FACTOR (dB /m)	CABLE LOSS (dB)	PREAMP FACTOR (dB)	ANTENNA HEIGHT (cm)	TABLE ANGLE (Degree)	REMARK
5150	49.22	50.75	54	-4.78	37.26	7.42	46.21	200	110	Average
5150	59.49	61.02	74	-14.51	37.26	7.42	46.21	200	110	Peak
5320	94.12	95.57			37.33	7.46	46.24	200	110	Average
5320	100.57	102.02			37.33	7.46	46.24	200	110	Peak
5350	48.82	50.26	54	-5.18	37.34	7.47	46.25	200	110	Average
5350	59.13	60.57	74	-14.87	37.34	7.47	46.25	200	110	Peak

REMARKS:

- Emission Level = Read Level+ Antenna Factor + Cable Loss- Preamp Factor
Margin value = Emission level – Limit value.
- 5320MHz: Fundamental frequency.



802.11n (40MHz)

CHANNEL	TX Channel 54	DETECTOR FUNCTION	Peak (PK)
FREQUENCY RANGE	1GHz ~ 40GHz		Average (AV)

ANTENNA POLARITY & TEST DISTANCE: HORIZONTAL AT 3 M										
FREQ. (MHz)	EMISSION LEVEL (dBuV/m)	READ LEVEL (dBuV)	LIMIT (dBuV/m)	MARGIN (dB)	ANTENNA FACTOR (dB /m)	CABLE LOSS (dB)	PREAMP FACTOR (dB)	ANTENNA HEIGHT (cm)	TABLE ANGLE (Degree)	REMARK
5150	49.21	50.74	54	-4.79	37.26	7.42	46.21	155	80	Average
5150	58.32	59.85	74	-15.68	37.26	7.42	46.21	155	80	Peak
5270	88.37	89.84			37.31	7.45	46.23	155	80	Average
5270	96.54	98.01			37.31	7.45	46.23	155	80	Peak
5350	47.94	49.38	54	-6.06	37.34	7.47	46.25	155	80	Average
5350	58.52	59.96	74	-15.48	37.34	7.47	46.25	155	80	Peak

ANTENNA POLARITY & TEST DISTANCE: VERTICAL AT 3 M										
FREQ. (MHz)	EMISSION LEVEL (dBuV/m)	READ LEVEL (dBuV)	LIMIT (dBuV/m)	MARGIN (dB)	ANTENNA FACTOR (dB /m)	CABLE LOSS (dB)	PREAMP FACTOR (dB)	ANTENNA HEIGHT (cm)	TABLE ANGLE (Degree)	REMARK
5150	49.24	50.77	54	-4.76	37.26	7.42	46.21	100	100	Average
5150	58.91	60.44	74	-15.09	37.26	7.42	46.21	100	100	Peak
5270	86.78	88.25			37.31	7.45	46.23	100	100	Average
5270	96.13	97.6			37.31	7.45	46.23	100	100	Peak
5350	47.89	49.33	54	-6.11	37.34	7.47	46.25	100	100	Average
5350	57.77	59.21	74	-16.23	37.34	7.47	46.25	100	100	Peak

REMARKS:

1. Emission Level = Read Level+ Antenna Factor + Cable Loss- Preamp Factor
Margin value = Emission level – Limit value.
2. 5270MHz: Fundamental frequency.



CHANNEL	TX Channel 62	DETECTOR FUNCTION	Peak (PK)
FREQUENCY RANGE	1GHz ~ 40GHz		Average (AV)

ANTENNA POLARITY & TEST DISTANCE: HORIZONTAL AT 3 M										
FREQ. (MHz)	EMISSION LEVEL (dBuV/m)	READ LEVEL (dBuV)	LIMIT (dBuV/m)	MARGIN (dB)	ANTENNA FACTOR (dB /m)	CABLE LOSS (dB)	PREAMP FACTOR (dB)	ANTENNA HEIGHT (cm)	TABLE ANGLE (Degree)	REMARK
5150	49.22	50.75	54	-4.78	37.26	7.42	46.21	145	70	Average
5150	59.28	60.81	74	-14.72	37.26	7.42	46.21	145	70	Peak
5310	89.15	90.61			37.32	7.46	46.24	145	70	Average
5310	97.03	98.49			37.32	7.46	46.24	145	70	Peak
5350	50.37	51.81	54	-3.63	37.34	7.47	46.25	145	70	Average
5350	60.92	62.36	74	-13.08	37.34	7.47	46.25	145	70	Peak

ANTENNA POLARITY & TEST DISTANCE: VERTICAL AT 3 M										
FREQ. (MHz)	EMISSION LEVEL (dBuV/m)	READ LEVEL (dBuV)	LIMIT (dBuV/m)	MARGIN (dB)	ANTENNA FACTOR (dB /m)	CABLE LOSS (dB)	PREAMP FACTOR (dB)	ANTENNA HEIGHT (cm)	TABLE ANGLE (Degree)	REMARK
5150	49.22	50.75	54	-4.78	37.26	7.42	46.21	200	116	Average
5150	59.19	60.72	74	-14.81	37.26	7.42	46.21	200	116	Peak
5310	90.61	92.07			37.32	7.46	46.24	200	116	Average
5310	96.9	98.36			37.32	7.46	46.24	200	116	Peak
5350	51.48	52.92	54	-2.52	37.34	7.47	46.25	200	116	Average
5350	61.67	63.11	74	-12.33	37.34	7.47	46.25	200	116	Peak

REMARKS:

- Emission Level = Read Level+ Antenna Factor + Cable Loss- Preamp Factor
Margin value = Emission level – Limit value.
- 5310MHz: Fundamental frequency.



802.11ac (80MHz)

CHANNEL	TX Channel 58	DETECTOR FUNCTION	Peak (PK)
FREQUENCY RANGE	1GHz ~ 40GHz		Average (AV)

ANTENNA POLARITY & TEST DISTANCE: HORIZONTAL AT 3 M										
FREQ. (MHz)	EMISSION LEVEL (dBuV/m)	READ LEVEL (dBuV)	LIMIT (dBuV/m)	MARGIN (dB)	ANTENNA FACTOR (dB /m)	CABLE LOSS (dB)	PREAMP FACTOR (dB)	ANTENNA HEIGHT (cm)	TABLE ANGLE (Degree)	REMARK
5150	49.26	50.79	54	-4.74	37.26	7.42	46.21	110	70	Average
5150	60.48	62.01	74	-13.52	37.26	7.42	46.21	110	70	Peak
5290	86.02	87.49			37.32	7.45	46.24	110	70	Average
5290	94.07	95.54			37.32	7.45	46.24	110	70	Peak
5350	49.58	51.02	54	-4.42	37.34	7.47	46.25	110	70	Average
5350	59.79	61.23	74	-14.21	37.34	7.47	46.25	110	70	Peak

ANTENNA POLARITY & TEST DISTANCE: VERTICAL AT 3 M										
FREQ. (MHz)	EMISSION LEVEL (dBuV/m)	READ LEVEL (dBuV)	LIMIT (dBuV/m)	MARGIN (dB)	ANTENNA FACTOR (dB /m)	CABLE LOSS (dB)	PREAMP FACTOR (dB)	ANTENNA HEIGHT (cm)	TABLE ANGLE (Degree)	REMARK
5150	49.39	50.92	54	-4.61	37.26	7.42	46.21	200	83	Average
5150	58.54	60.07	74	-15.46	37.26	7.42	46.21	200	83	Peak
5290	87.68	89.15			37.32	7.45	46.24	200	83	Average
5290	95.66	97.13			37.32	7.45	46.24	200	83	Peak
5350	51.21	52.65	54	-2.79	37.34	7.47	46.25	200	83	Average
5350	64.27	65.71	74	-9.73	37.34	7.47	46.25	200	83	Peak

REMARKS:

1. Emission Level = Read Level+ Antenna Factor + Cable Loss- Preamp Factor
Margin value = Emission level – Limit value.
2. 5290MHz: Fundamental frequency.



Band 3

802.11a

CHANNEL	TX Channel 100	DETECTOR FUNCTION	Peak (PK)
FREQUENCY RANGE	1GHz ~ 40GHz		Average (AV)

ANTENNA POLARITY & TEST DISTANCE: HORIZONTAL AT 3 M										
FREQ. (MHz)	EMISSION LEVEL (dBuV/m)	READ LEVEL (dBuV)	LIMIT (dBuV/m)	MARGIN (dB)	ANTENNA FACTOR (dB /m)	CABLE LOSS (dB)	PREAMP FACTOR (dB)	ANTENNA HEIGHT (cm)	TABLE ANGLE (Degree)	REMARK
5460	47.97	49.37	54	-6.03	37.38	7.49	46.27	100	60	Average
5460	57.42	58.82	74	-16.58	37.38	7.49	46.27	100	60	Peak
#5470	57.46	58.85	68.3	-10.88	37.39	7.49	46.27	100	60	Peak
5500	92.19	93.57			37.4	7.5	46.28	100	60	Average
5500	100.03	101.41			37.4	7.5	46.28	100	60	Peak
ANTENNA POLARITY & TEST DISTANCE: VERTICAL AT 3 M										
FREQ. (MHz)	EMISSION LEVEL (dBuV/m)	READ LEVEL (dBuV)	LIMIT (dBuV/m)	MARGIN (dB)	ANTENNA FACTOR (dB /m)	CABLE LOSS (dB)	PREAMP FACTOR (dB)	ANTENNA HEIGHT (cm)	TABLE ANGLE (Degree)	REMARK
5460	48.02	49.42	54	-5.98	37.38	7.49	46.27	200	130	Average
5460	57.61	59.01	74	-16.39	37.38	7.49	46.27	200	130	Peak
#5470	57.64	59.03	68.3	-10.66	37.39	7.49	46.27	200	130	Peak
5500	93.77	95.15			37.4	7.5	46.28	200	130	Average
5500	101.6	102.98			37.4	7.5	46.28	200	130	Peak

REMARKS:

- Emission Level = Read Level+ Antenna Factor + Cable Loss- Preamp Factor
Margin value = Emission level – Limit value.
- 5500MHz: Fundamental frequency.
- #: Out of restricted band.



CHANNEL	TX Channel 116	DETECTOR FUNCTION	Peak (PK)
FREQUENCY RANGE	1GHz ~ 40GHz		Average (AV)

ANTENNA POLARITY & TEST DISTANCE: HORIZONTAL AT 3 M										
FREQ. (MHz)	EMISSION LEVEL (dBuV/m)	READ LEVEL (dBuV)	LIMIT (dBuV/m)	MARGIN (dB)	ANTENNA FACTOR (dB /m)	CABLE LOSS (dB)	PREAMP FACTOR (dB)	ANTENNA HEIGHT (cm)	TABLE ANGLE (Degree)	REMARK
5460	42.96	44.36	54	-11.04	37.38	7.49	46.27	130	80	Average
5460	55.92	57.32	74	-18.08	37.38	7.49	46.27	130	80	Peak
#5470	54.82	56.21	68.3	-13.48	37.39	7.49	46.27	130	80	Peak
5580	92.77	94.02			37.45	7.58	46.28	130	80	Average
5580	98.56	99.81			37.45	7.58	46.28	130	80	Peak

ANTENNA POLARITY & TEST DISTANCE: VERTICAL AT 3 M										
FREQ. (MHz)	EMISSION LEVEL (dBuV/m)	READ LEVEL (dBuV)	LIMIT (dBuV/m)	MARGIN (dB)	ANTENNA FACTOR (dB /m)	CABLE LOSS (dB)	PREAMP FACTOR (dB)	ANTENNA HEIGHT (cm)	TABLE ANGLE (Degree)	REMARK
5460	41.93	43.33	54	-12.07	37.38	7.49	46.27	100	90	Average
5460	58.47	59.87	74	-15.53	37.38	7.49	46.27	100	90	Peak
#5470	56.48	57.87	68.3	-11.82	37.39	7.49	46.27	100	90	Peak
5580	92.18	93.43			37.45	7.58	46.28	100	90	Average
5580	102.68	103.93			37.45	7.58	46.28	100	90	Peak

REMARKS:

- Emission Level = Read Level+ Antenna Factor + Cable Loss- Preamp Factor
Margin value = Emission level – Limit value.
- 5580MHz: Fundamental frequency.
- #: Out of restricted band.



CHANNEL	TX Channel 140	DETECTOR FUNCTION	Peak (PK)
FREQUENCY RANGE	1GHz ~ 40GHz		Average (AV)

ANTENNA POLARITY & TEST DISTANCE: HORIZONTAL AT 3 M										
FREQ. (MHz)	EMISSION LEVEL (dBuV/m)	READ LEVEL (dBuV)	LIMIT (dBuV/m)	MARGIN (dB)	ANTENNA FACTOR (dB /m)	CABLE LOSS (dB)	PREAMP FACTOR (dB)	ANTENNA HEIGHT (cm)	TABLE ANGLE (Degree)	REMARK
5700	94.81	95.87			37.52	7.7	46.28	200	70	Average
5700	102.87	103.93			37.52	7.7	46.28	200	70	Peak
#5725	59.55	60.57	68.3	-8.75	37.53	7.73	46.28	200	70	Peak
ANTENNA POLARITY & TEST DISTANCE: VERTICAL AT 3 M										
FREQ. (MHz)	EMISSION LEVEL (dBuV/m)	READ LEVEL (dBuV)	LIMIT (dBuV/m)	MARGIN (dB)	ANTENNA FACTOR (dB /m)	CABLE LOSS (dB)	PREAMP FACTOR (dB)	ANTENNA HEIGHT (cm)	TABLE ANGLE (Degree)	REMARK
5700	97.71	98.77			37.52	7.7	46.28	200	110	Average
5700	105.7	106.76			37.52	7.7	46.28	200	110	Peak
#5725	64.74	65.76	68.3	-3.56	37.53	7.73	46.28	200	110	Peak

REMARKS:

- Emission Level = Read Level+ Antenna Factor + Cable Loss- Preamp Factor
Margin value = Emission level – Limit value.
- 5700MHz: Fundamental frequency.
- #: Out of restricted band.



802.11n (20MHz)

CHANNEL	TX Channel 100	DETECTOR FUNCTION	Peak (PK)
FREQUENCY RANGE	1GHz ~ 40GHz		Average (AV)

ANTENNA POLARITY & TEST DISTANCE: HORIZONTAL AT 3 M										
FREQ. (MHz)	EMISSION LEVEL (dBuV/m)	READ LEVEL (dBuV)	LIMIT (dBuV/m)	MARGIN (dB)	ANTENNA FACTOR (dB /m)	CABLE LOSS (dB)	PREAMP FACTOR (dB)	ANTENNA HEIGHT (cm)	TABLE ANGLE (Degree)	REMARK
5460	47.91	49.31	54	-6.09	37.38	7.49	46.27	100	70	Average
5460	57.65	59.05	74	-16.35	37.38	7.49	46.27	100	70	Peak
#5470	58.19	59.58	68.3	-10.11	37.39	7.49	46.27	100	70	Peak
5500	89.76	91.14			37.4	7.5	46.28	100	70	Average
5500	97.9	99.28			37.4	7.5	46.28	100	70	Peak

ANTENNA POLARITY & TEST DISTANCE: VERTICAL AT 3 M										
FREQ. (MHz)	EMISSION LEVEL (dBuV/m)	READ LEVEL (dBuV)	LIMIT (dBuV/m)	MARGIN (dB)	ANTENNA FACTOR (dB /m)	CABLE LOSS (dB)	PREAMP FACTOR (dB)	ANTENNA HEIGHT (cm)	TABLE ANGLE (Degree)	REMARK
5460	48.09	49.49	54	-5.91	37.38	7.49	46.27	200	100	Average
5460	56.73	58.13	74	-17.27	37.38	7.49	46.27	200	100	Peak
#5470	57.86	59.25	68.3	-10.44	37.39	7.49	46.27	200	100	Peak
5500	93.6	94.98			37.4	7.5	46.28	200	100	Average
5500	103.51	104.89			37.4	7.5	46.28	200	100	Peak

REMARKS:

1. Emission Level = Read Level+ Antenna Factor + Cable Loss- Preamp Factor
Margin value = Emission level – Limit value.
2. 5500MHz: Fundamental frequency.
3. #: Out of restricted band.



CHANNEL	TX Channel 116	DETECTOR FUNCTION	Peak (PK)
FREQUENCY RANGE	1GHz ~ 40GHz		Average (AV)

ANTENNA POLARITY & TEST DISTANCE: HORIZONTAL AT 3 M										
FREQ. (MHz)	EMISSION LEVEL (dBuV/m)	READ LEVEL (dBuV)	LIMIT (dBuV/m)	MARGIN (dB)	ANTENNA FACTOR (dB /m)	CABLE LOSS (dB)	PREAMP FACTOR (dB)	ANTENNA HEIGHT (cm)	TABLE ANGLE (Degree)	REMARK
5460	43.83	45.23	54	-10.17	37.38	7.49	46.27	130	100	Average
5460	54.72	56.12	74	-19.28	37.38	7.49	46.27	130	100	Peak
#5470	52.72	54.11	68.3	-15.58	37.39	7.49	46.27	130	100	Peak
5580	92.96	94.21			37.45	7.58	46.28	130	100	Average
5580	100.98	102.23			37.45	7.58	46.28	130	100	Peak

ANTENNA POLARITY & TEST DISTANCE: VERTICAL AT 3 M										
FREQ. (MHz)	EMISSION LEVEL (dBuV/m)	READ LEVEL (dBuV)	LIMIT (dBuV/m)	MARGIN (dB)	ANTENNA FACTOR (dB /m)	CABLE LOSS (dB)	PREAMP FACTOR (dB)	ANTENNA HEIGHT (cm)	TABLE ANGLE (Degree)	REMARK
5460	41.56	42.96	54	-12.44	37.38	7.49	46.27	100	100	Average
5460	53.92	55.32	74	-20.08	37.38	7.49	46.27	100	100	Peak
#5470	54.93	56.32	68.3	-13.37	37.39	7.49	46.27	100	100	Peak
5580	90.77	92.02			37.45	7.58	46.28	100	100	Average
5580	98.34	99.59			37.45	7.58	46.28	100	100	Peak

REMARKS:

- Emission Level = Read Level+ Antenna Factor + Cable Loss- Preamp Factor
Margin value = Emission level – Limit value.
- 5580MHz: Fundamental frequency.



CHANNEL	TX Channel 140	DETECTOR FUNCTION	Peak (PK)
FREQUENCY RANGE	1GHz ~ 40GHz		Average (AV)

ANTENNA POLARITY & TEST DISTANCE: HORIZONTAL AT 3 M										
FREQ. (MHz)	EMISSION LEVEL (dBuV/m)	READ LEVEL (dBuV)	LIMIT (dBuV/m)	MARGIN (dB)	ANTENNA FACTOR (dB /m)	CABLE LOSS (dB)	PREAMP FACTOR (dB)	ANTENNA HEIGHT (cm)	TABLE ANGLE (Degree)	REMARK
5700	93.27	94.33			37.52	7.7	46.28	200	60	Average
5700	101.03	102.09			37.52	7.7	46.28	200	60	Peak
#5725	65.74	66.76	68.3	-1.54	37.53	7.73	46.28	200	60	Peak
ANTENNA POLARITY & TEST DISTANCE: VERTICAL AT 3 M										
FREQ. (MHz)	EMISSION LEVEL (dBuV/m)	READ LEVEL (dBuV)	LIMIT (dBuV/m)	MARGIN (dB)	ANTENNA FACTOR (dB /m)	CABLE LOSS (dB)	PREAMP FACTOR (dB)	ANTENNA HEIGHT (cm)	TABLE ANGLE (Degree)	REMARK
5700	97.28	98.34			37.52	7.7	46.28	200	120	Average
5700	104.83	105.89			37.52	7.7	46.28	200	120	Peak
#5725	63.4	64.42	68.3	-3.88	37.53	7.73	46.28	200	120	Peak

REMARKS:

- Emission Level = Read Level+ Antenna Factor + Cable Loss- Preamp Factor
Margin value = Emission level – Limit value.
- 5700MHz: Fundamental frequency.
- #: Out of restricted band.



802.11n (40MHz)

CHANNEL	TX Channel 102	DETECTOR FUNCTION	Peak (PK)
FREQUENCY RANGE	1GHz ~ 40GHz		Average (AV)

ANTENNA POLARITY & TEST DISTANCE: HORIZONTAL AT 3 M										
FREQ. (MHz)	EMISSION LEVEL (dBuV/m)	READ LEVEL (dBuV)	LIMIT (dBuV/m)	MARGIN (dB)	ANTENNA FACTOR (dB /m)	CABLE LOSS (dB)	PREAMP FACTOR (dB)	ANTENNA HEIGHT (cm)	TABLE ANGLE (Degree)	REMARK
5460	48.62	50.02	54	-5.38	37.38	7.49	46.27	100	60	Average
5460	58.97	60.37	74	-15.03	37.38	7.49	46.27	100	60	Peak
#5470	57.67	59.06	68.3	-10.63	37.39	7.49	46.27	100	60	Peak
5510	87.65	89.01			37.41	7.51	46.28	100	60	Average
5510	95.83	97.19			37.41	7.51	46.28	100	60	Peak

ANTENNA POLARITY & TEST DISTANCE: VERTICAL AT 3 M										
FREQ. (MHz)	EMISSION LEVEL (dBuV/m)	READ LEVEL (dBuV)	LIMIT (dBuV/m)	MARGIN (dB)	ANTENNA FACTOR (dB /m)	CABLE LOSS (dB)	PREAMP FACTOR (dB)	ANTENNA HEIGHT (cm)	TABLE ANGLE (Degree)	REMARK
5460	49.51	50.91	54	-4.49	37.38	7.49	46.27	200	130	Average
5460	57.94	59.34	74	-16.06	37.38	7.49	46.27	200	130	Peak
#5470	60.53	61.92	68.3	-7.77	37.39	7.49	46.27	200	130	Peak
5510	90.75	92.11			37.41	7.51	46.28	200	130	Average
5510	98.17	99.53			37.41	7.51	46.28	200	130	Peak

REMARKS:

- Emission Level = Read Level+ Antenna Factor + Cable Loss- Preamp Factor
Margin value = Emission level – Limit value.
- 5510MHz: Fundamental frequency.
- #: Out of restricted band.



CHANNEL	TX Channel 110	DETECTOR FUNCTION	Peak (PK)
FREQUENCY RANGE	1GHz ~ 40GHz		Average (AV)

ANTENNA POLARITY & TEST DISTANCE: HORIZONTAL AT 3 M										
FREQ. (MHz)	EMISSION LEVEL (dBuV/m)	READ LEVEL (dBuV)	LIMIT (dBuV/m)	MARGIN (dB)	ANTENNA FACTOR (dB /m)	CABLE LOSS (dB)	PREAMP FACTOR (dB)	ANTENNA HEIGHT (cm)	TABLE ANGLE (Degree)	REMARK
5460	43.82	45.22	54	-10.18	37.38	7.49	46.27	130	80	Average
5460	57.24	58.64	74	-16.76	37.38	7.49	46.27	130	80	Peak
#5470	53.97	55.36	68.3	-14.33	37.39	7.49	46.27	130	80	Peak
5550	89.13	90.43			37.43	7.55	46.28	130	80	Average
5550	95.98	97.28			37.43	7.55	46.28	130	80	Peak

ANTENNA POLARITY & TEST DISTANCE: VERTICAL AT 3 M										
FREQ. (MHz)	EMISSION LEVEL (dBuV/m)	READ LEVEL (dBuV)	LIMIT (dBuV/m)	MARGIN (dB)	ANTENNA FACTOR (dB /m)	CABLE LOSS (dB)	PREAMP FACTOR (dB)	ANTENNA HEIGHT (cm)	TABLE ANGLE (Degree)	REMARK
5460	41.83	43.23	54	-12.17	37.38	7.49	46.27	100	90	Average
5460	58.47	59.87	74	-15.53	37.38	7.49	46.27	100	90	Peak
#5470	54.07	55.46	68.3	-14.23	37.39	7.49	46.27	100	90	Peak
5550	87.41	88.71			37.43	7.55	46.28	100	90	Average
5550	93.28	94.58			37.43	7.55	46.28	100	90	Peak

REMARKS:

- Emission Level = Read Level+ Antenna Factor + Cable Loss- Preamp Factor
Margin value = Emission level – Limit value.
- 5550MHz: Fundamental frequency.
- #: Out of restricted band.



CHANNEL	TX Channel 134	DETECTOR FUNCTION	Peak (PK)
FREQUENCY RANGE	1GHz ~ 40GHz		Average (AV)

ANTENNA POLARITY & TEST DISTANCE: HORIZONTAL AT 3 M										
FREQ. (MHz)	EMISSION LEVEL (dBuV/m)	READ LEVEL (dBuV)	LIMIT (dBuV/m)	MARGIN (dB)	ANTENNA FACTOR (dB /m)	CABLE LOSS (dB)	PREAMP FACTOR (dB)	ANTENNA HEIGHT (cm)	TABLE ANGLE (Degree)	REMARK
5670	90.97	92.08			37.5	7.67	46.28	200	70	Average
5670	96.86	97.97			37.5	7.67	46.28	200	70	Peak
#5725	61.82	62.84	68.3	-6.48	37.53	7.73	46.28	200	70	Peak
ANTENNA POLARITY & TEST DISTANCE: VERTICAL AT 3 M										
FREQ. (MHz)	EMISSION LEVEL (dBuV/m)	READ LEVEL (dBuV)	LIMIT (dBuV/m)	MARGIN (dB)	ANTENNA FACTOR (dB /m)	CABLE LOSS (dB)	PREAMP FACTOR (dB)	ANTENNA HEIGHT (cm)	TABLE ANGLE (Degree)	REMARK
5670	94.62	95.73			37.5	7.67	46.28	200	110	Average
5670	100.36	101.47			37.5	7.67	46.28	200	110	Peak
#5725	62.03	63.05	68.3	-6.27	37.53	7.73	46.28	200	110	Peak

REMARKS:

- Emission Level = Read Level+ Antenna Factor + Cable Loss- Preamp Factor
Margin value = Emission level – Limit value.
- 5670MHz: Fundamental frequency.
- #: Out of restricted band.



802.11ac (80MHz)

CHANNEL	TX Channel 106	DETECTOR FUNCTION	Peak (PK)
FREQUENCY RANGE	1GHz ~ 40GHz		Average (AV)

ANTENNA POLARITY & TEST DISTANCE: HORIZONTAL AT 3 M										
FREQ. (MHz)	EMISSION LEVEL (dBuV/m)	READ LEVEL (dBuV)	LIMIT (dBuV/m)	MARGIN (dB)	ANTENNA FACTOR (dB /m)	CABLE LOSS (dB)	PREAMP FACTOR (dB)	ANTENNA HEIGHT (cm)	TABLE ANGLE (Degree)	REMARK
5460	51.25	52.65	54	-2.75	37.38	7.49	46.27	140	80	Average
5460	60.14	61.54	74	-13.86	37.38	7.49	46.27	140	80	Peak
#5470	60.97	62.36	68.3	-7.33	37.39	7.49	46.27	140	80	Peak
5530	86.1	87.43			37.42	7.53	46.28	140	80	Average
5530	94.3	95.63			37.42	7.53	46.28	140	80	Peak

ANTENNA POLARITY & TEST DISTANCE: VERTICAL AT 3 M										
FREQ. (MHz)	EMISSION LEVEL (dBuV/m)	READ LEVEL (dBuV)	LIMIT (dBuV/m)	MARGIN (dB)	ANTENNA FACTOR (dB /m)	CABLE LOSS (dB)	PREAMP FACTOR (dB)	ANTENNA HEIGHT (cm)	TABLE ANGLE (Degree)	REMARK
5460	50.39	51.79	54	-3.61	37.38	7.49	46.27	160	130	Average
5460	62.38	63.78	74	-11.62	37.38	7.49	46.27	160	130	Peak
#5470	62.2	63.59	68.3	-6.1	37.39	7.49	46.27	160	130	Peak
5530	86.55	87.88			37.42	7.53	46.28	160	130	Average
5530	95.36	96.69			37.42	7.53	46.28	160	130	Peak

REMARKS:

- Emission Level = Read Level+ Antenna Factor + Cable Loss- Preamp Factor
Margin value = Emission level – Limit value.
- 5530MHz: Fundamental frequency.
- #: Out of restricted band.



Band 4

802.11a

CHANNEL	TX Channel 149	DETECTOR FUNCTION	Peak (PK)
FREQUENCY RANGE	1GHz ~ 40GHz		Average (AV)

ANTENNA POLARITY & TEST DISTANCE: HORIZONTAL AT 3 M										
FREQ. (MHz)	EMISSION LEVEL (dBuV/m)	READ LEVEL (dBuV)	LIMIT (dBuV/m)	MARGIN (dB)	ANTENNA FACTOR (dB /m)	CABLE LOSS (dB)	PREAMP FACTOR (dB)	ANTENNA HEIGHT (cm)	TABLE ANGLE (Degree)	REMARK
5745	90.53	91.51			37.55	7.75	46.28	100	110	Average
5745	99.81	100.79			37.55	7.75	46.28	100	110	Peak
ANTENNA POLARITY & TEST DISTANCE: VERTICAL AT 3 M										
FREQ. (MHz)	EMISSION LEVEL (dBuV/m)	READ LEVEL (dBuV)	LIMIT (dBuV/m)	MARGIN (dB)	ANTENNA FACTOR (dB /m)	CABLE LOSS (dB)	PREAMP FACTOR (dB)	ANTENNA HEIGHT (cm)	TABLE ANGLE (Degree)	REMARK
5745	97.18	98.16			37.55	7.75	46.28	200	85	Average
5745	104.35	105.33			37.55	7.75	46.28	200	85	Peak

REMARKS:

1. Emission Level = Read Level+ Antenna Factor + Cable Loss- Preamp Factor
Margin value = Emission level – Limit value.
2. 5745MHz: Fundamental frequency.



**BUREAU
VERITAS**

Test Report No.: RF180523W002-3

OOBE DATA

802.11a

ANTENNA POLARITY & TEST DISTANCE: HORIZONTAL AT 3 M											
FREQ. (MHz)	EMISSION LEVEL (dBuV/m)	READ LEVEL (dBuV)	LIMIT (dBuV/m)	MARGIN (dB)	ANTENNA FACTOR (dB /m)	CABLE LOSS (dB)	PREAMP FACTOR (dB)	ANTENNA HEIGHT (cm)	TABLE ANGLE (Degree)	REMARK	
5626.48	57.43	58.6	68.3	-10.87	37.48	7.63	46.28	100	110	Peak	
5966.1	57.02	57.64	68.3	-11.28	37.68	7.98	46.28	100	110	Peak	
ANTENNA POLARITY & TEST DISTANCE: VERTICAL AT 3 M											
FREQ. (MHz)	EMISSION LEVEL (dBuV/m)	READ LEVEL (dBuV)	LIMIT (dBuV/m)	MARGIN (dB)	ANTENNA FACTOR (dB /m)	CABLE LOSS (dB)	PREAMP FACTOR (dB)	ANTENNA HEIGHT (cm)	TABLE ANGLE (Degree)	REMARK	
5597.98	58.02	59.24	68.3	-10.28	37.46	7.6	46.28	100	110	Peak	
5980.83	58.66	59.26	68.3	-9.64	37.69	7.99	46.28	100	110	Peak	

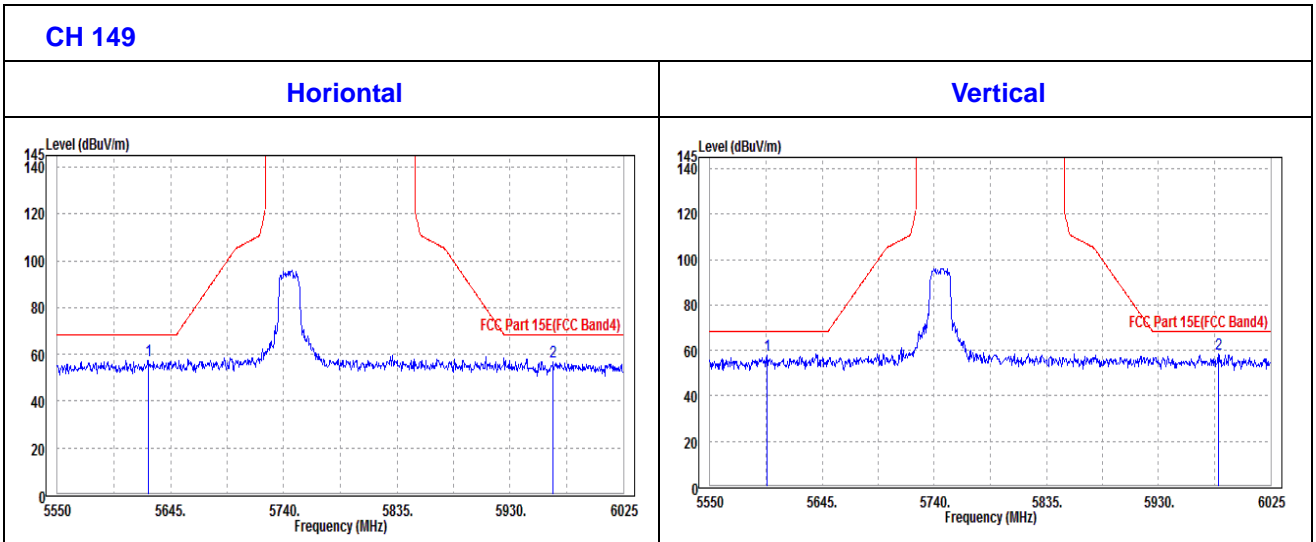



CHANNEL	TX Channel 157	DETECTOR FUNCTION	Peak (PK)
FREQUENCY RANGE	1GHz ~ 40GHz		Average (AV)

ANTENNA POLARITY & TEST DISTANCE: HORIZONTAL AT 3 M										
FREQ. (MHz)	EMISSION LEVEL (dBuV/m)	READ LEVEL (dBuV)	LIMIT (dBuV/m)	MARGIN (dB)	ANTENNA FACTOR (dB /m)	CABLE LOSS (dB)	PREAMP FACTOR (dB)	ANTENNA HEIGHT (cm)	TABLE ANGLE (Degree)	REMARK
5785	92.35	93.27			37.57	7.79	46.28	100	60	Average
5785	100.96	101.88			37.57	7.79	46.28	100	60	Peak

ANTENNA POLARITY & TEST DISTANCE: VERTICAL AT 3 M										
FREQ. (MHz)	EMISSION LEVEL (dBuV/m)	READ LEVEL (dBuV)	LIMIT (dBuV/m)	MARGIN (dB)	ANTENNA FACTOR (dB /m)	CABLE LOSS (dB)	PREAMP FACTOR (dB)	ANTENNA HEIGHT (cm)	TABLE ANGLE (Degree)	REMARK
5785	92.35	93.27			37.57	7.79	46.28	100	60	Average
5785	100.96	101.88			37.57	7.79	46.28	100	60	Peak

REMARKS:

1. Emission Level = Read Level+ Antenna Factor + Cable Loss- Preamp Factor
Margin value = Emission level – Limit value.
2. 5785MHz: Fundamental frequency.



Oobe Data

802.11a

ANTENNA POLARITY & TEST DISTANCE: HORIZONTAL AT 3 M										
FREQ. (MHz)	EMISSION LEVEL (dBuV/m)	READ LEVEL (dBuV)	LIMIT (dBuV/m)	MARGIN (dB)	ANTENNA FACTOR (dB /m)	CABLE LOSS (dB)	PREAMP FACTOR (dB)	ANTENNA HEIGHT (cm)	TABLE ANGLE (Degree)	REMARK
5605.1	57.94	59.15	68.3	-10.36	37.46	7.61	46.28	100	110	Peak
5972.28	59.01	59.63	68.3	-9.29	37.68	7.98	46.28	100	110	Peak
ANTENNA POLARITY & TEST DISTANCE: VERTICAL AT 3 M										
FREQ. (MHz)	EMISSION LEVEL (dBuV/m)	READ LEVEL (dBuV)	LIMIT (dBuV/m)	MARGIN (dB)	ANTENNA FACTOR (dB /m)	CABLE LOSS (dB)	PREAMP FACTOR (dB)	ANTENNA HEIGHT (cm)	TABLE ANGLE (Degree)	REMARK
5619.35	57.34	58.53	68.3	-10.96	37.47	7.62	46.28	100	110	Peak
5968	59.67	60.29	68.3	-8.63	37.68	7.98	46.28	100	110	Peak

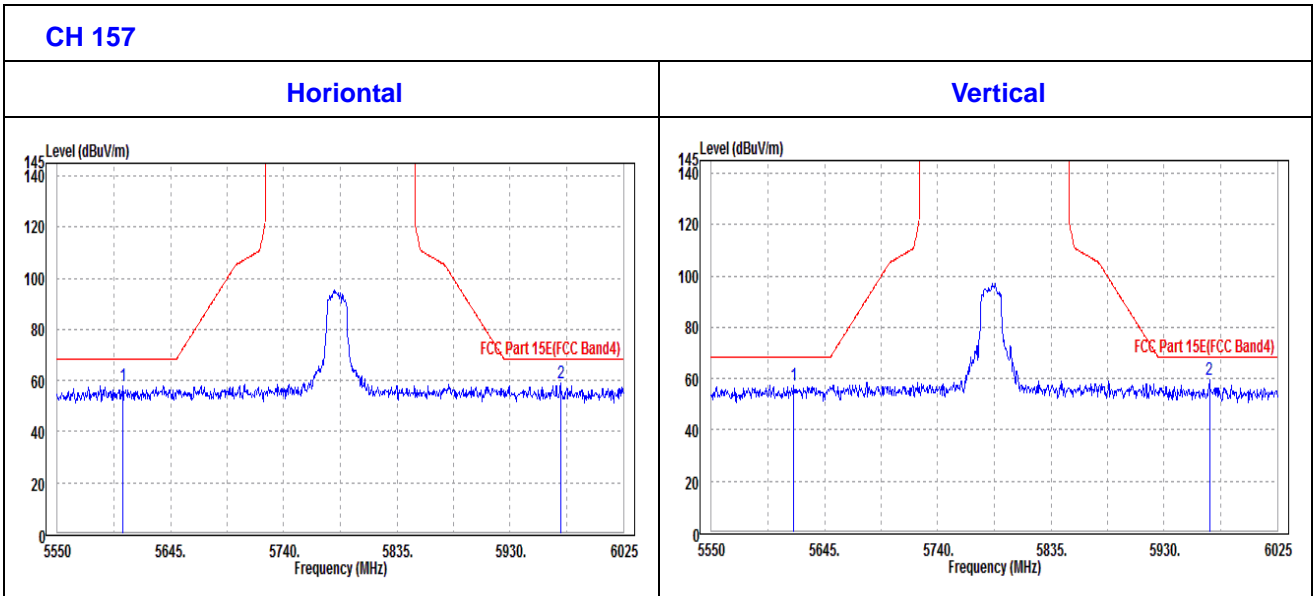



CHANNEL	TX Channel 165	DETECTOR FUNCTION	Peak (PK)
FREQUENCY RANGE	1GHz ~ 40GHz		Average (AV)

ANTENNA POLARITY & TEST DISTANCE: HORIZONTAL AT 3 M										
FREQ. (MHz)	EMISSION LEVEL (dBuV/m)	READ LEVEL (dBuV)	LIMIT (dBuV/m)	MARGIN (dB)	ANTENNA FACTOR (dB /m)	CABLE LOSS (dB)	PREAMP FACTOR (dB)	ANTENNA HEIGHT (cm)	TABLE ANGLE (Degree)	REMARK
5825	92.56	93.41			37.6	7.83	46.28	100	80	Average
5825	100.06	100.91			37.6	7.83	46.28	100	80	Peak

ANTENNA POLARITY & TEST DISTANCE: VERTICAL AT 3 M										
FREQ. (MHz)	EMISSION LEVEL (dBuV/m)	READ LEVEL (dBuV)	LIMIT (dBuV/m)	MARGIN (dB)	ANTENNA FACTOR (dB /m)	CABLE LOSS (dB)	PREAMP FACTOR (dB)	ANTENNA HEIGHT (cm)	TABLE ANGLE (Degree)	REMARK
5825	96.62	97.47			37.6	7.83	46.28	200	110	Average
5825	105.14	105.99			37.6	7.83	46.28	200	110	Peak

REMARKS:

1. Emission Level = Read Level+ Antenna Factor + Cable Loss- Preamp Factor
Margin value = Emission level – Limit value.
2. 5825MHz: Fundamental frequency.



Oobe Data

802.11a

ANTENNA POLARITY & TEST DISTANCE: HORIZONTAL AT 3 M										
FREQ. (MHz)	EMISSION LEVEL (dBuV/m)	READ LEVEL (dBuV)	LIMIT (dBuV/m)	MARGIN (dB)	ANTENNA FACTOR (dB /m)	CABLE LOSS (dB)	PREAMP FACTOR (dB)	ANTENNA HEIGHT (cm)	TABLE ANGLE (Degree)	REMARK
5616.03	56.51	57.7	68.3	-11.79	37.47	7.62	46.28	100	110	Peak
5940.45	57.13	57.8	68.3	-11.17	37.66	7.95	46.28	100	110	Peak
ANTENNA POLARITY & TEST DISTANCE: VERTICAL AT 3 M										
FREQ. (MHz)	EMISSION LEVEL (dBuV/m)	READ LEVEL (dBuV)	LIMIT (dBuV/m)	MARGIN (dB)	ANTENNA FACTOR (dB /m)	CABLE LOSS (dB)	PREAMP FACTOR (dB)	ANTENNA HEIGHT (cm)	TABLE ANGLE (Degree)	REMARK
5605.1	56.98	58.19	68.3	-11.32	37.46	7.61	46.28	100	110	Peak
5955.65	58.2	58.85	68.3	-10.1	37.67	7.96	46.28	100	110	Peak

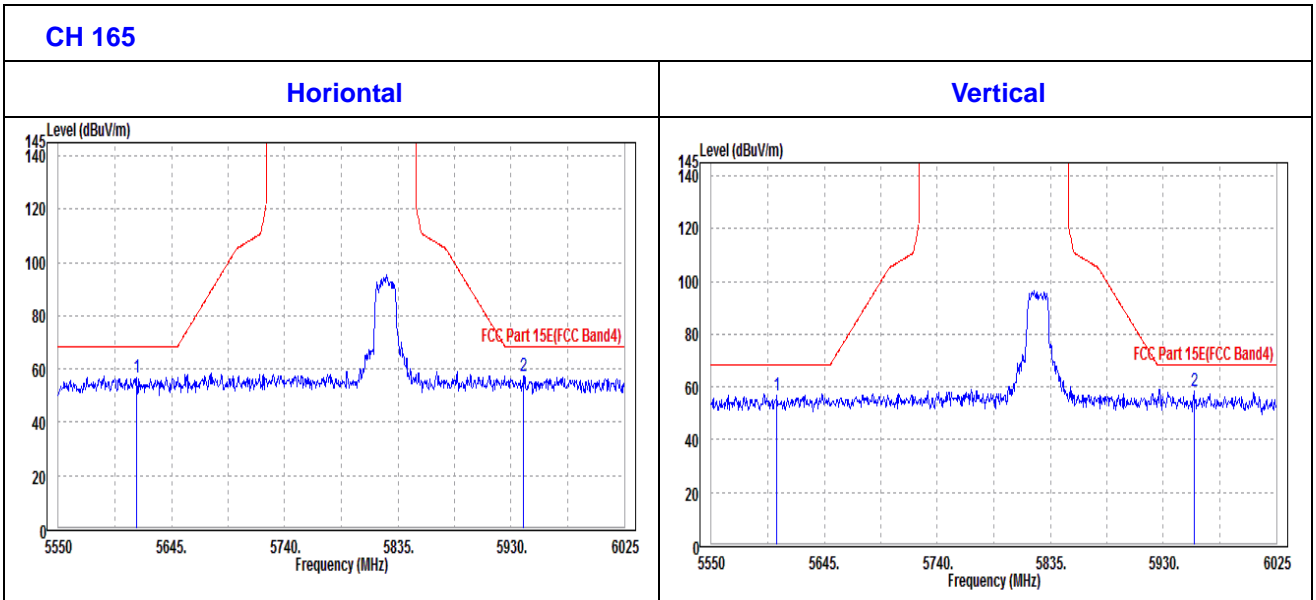



802.11n (20MHz)

CHANNEL	TX Channel 149	DETECTOR FUNCTION	Peak (PK)
FREQUENCY RANGE	1GHz ~ 40GHz		Average (AV)

ANTENNA POLARITY & TEST DISTANCE: HORIZONTAL AT 3 M										
FREQ. (MHz)	EMISSION LEVEL (dBuV/m)	READ LEVEL (dBuV)	LIMIT (dBuV/m)	MARGIN (dB)	ANTENNA FACTOR (dB /m)	CABLE LOSS (dB)	PREAMP FACTOR (dB)	ANTENNA HEIGHT (cm)	TABLE ANGLE (Degree)	REMARK
5745	94.5	95.48			37.55	7.75	46.28	100	70	Average
5745	108.24	109.22			37.55	7.75	46.28	100	70	Peak
ANTENNA POLARITY & TEST DISTANCE: VERTICAL AT 3 M										
FREQ. (MHz)	EMISSION LEVEL (dBuV/m)	READ LEVEL (dBuV)	LIMIT (dBuV/m)	MARGIN (dB)	ANTENNA FACTOR (dB /m)	CABLE LOSS (dB)	PREAMP FACTOR (dB)	ANTENNA HEIGHT (cm)	TABLE ANGLE (Degree)	REMARK
5745	97.33	98.31			37.55	7.75	46.28	200	120	Average
5745	107.13	108.11			37.55	7.75	46.28	200	120	Peak

REMARKS:

1. Emission Level = Read Level+ Antenna Factor + Cable Loss- Preamp Factor
Margin value = Emission level – Limit value.
2. 5745MHz: Fundamental frequency.



**BUREAU
VERITAS**

Test Report No.: RF180523W002-3

OUBE DATA

802.11n (20MHZ)

ANTENNA POLARITY & TEST DISTANCE: HORIZONTAL AT 3 M										
FREQ. (MHz)	EMISSION LEVEL (dBuV/m)	READ LEVEL (dBuV)	LIMIT (dBuV/m)	MARGIN (dB)	ANTENNA FACTOR (dB /m)	CABLE LOSS (dB)	PREAMP FACTOR (dB)	ANTENNA HEIGHT (cm)	TABLE ANGLE (Degree)	REMARK
5597.5	56.42	57.64	68.3	-11.88	37.46	7.6	46.28	100	110	Peak
5939.5	55.92	56.59	68.3	-12.38	37.66	7.95	46.28	100	110	Peak
ANTENNA POLARITY & TEST DISTANCE: VERTICAL AT 3 M										
FREQ. (MHz)	EMISSION LEVEL (dBuV/m)	READ LEVEL (dBuV)	LIMIT (dBuV/m)	MARGIN (dB)	ANTENNA FACTOR (dB /m)	CABLE LOSS (dB)	PREAMP FACTOR (dB)	ANTENNA HEIGHT (cm)	TABLE ANGLE (Degree)	REMARK
5602.25	56.9	58.12	68.3	-11.4	37.46	7.6	46.28	100	110	Peak
5961.83	57.38	58.01	68.3	-10.92	37.68	7.97	46.28	100	110	Peak

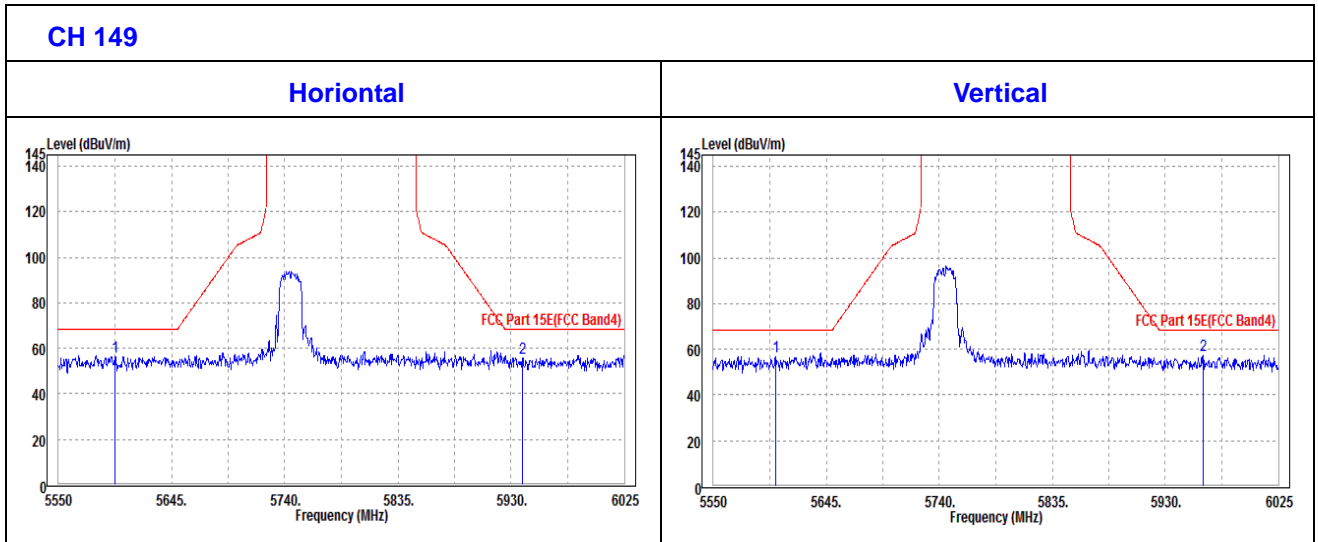



CHANNEL	TX Channel 157	DETECTOR FUNCTION	Peak (PK)
FREQUENCY RANGE	1GHz ~ 40GHz		Average (AV)

ANTENNA POLARITY & TEST DISTANCE: HORIZONTAL AT 3 M										
FREQ. (MHz)	EMISSION LEVEL (dBuV/m)	READ LEVEL (dBuV)	LIMIT (dBuV/m)	MARGIN (dB)	ANTENNA FACTOR (dB /m)	CABLE LOSS (dB)	PREAMP FACTOR (dB)	ANTENNA HEIGHT (cm)	TABLE ANGLE (Degree)	REMARK
5785	93.29	94.21			37.57	7.79	46.28	100	50	Average
5785	102.95	103.87			37.57	7.79	46.28	100	50	Peak

ANTENNA POLARITY & TEST DISTANCE: VERTICAL AT 3 M										
FREQ. (MHz)	EMISSION LEVEL (dBuV/m)	READ LEVEL (dBuV)	LIMIT (dBuV/m)	MARGIN (dB)	ANTENNA FACTOR (dB /m)	CABLE LOSS (dB)	PREAMP FACTOR (dB)	ANTENNA HEIGHT (cm)	TABLE ANGLE (Degree)	REMARK
5785	102.37	103.29			37.57	7.79	46.28	200	80	Average
5785	112.19	113.11			37.57	7.79	46.28	200	80	Peak

REMARKS:

1. Emission Level = Read Level+ Antenna Factor + Cable Loss- Preamp Factor
Margin value = Emission level – Limit value.
2. 5785MHz: Fundamental frequency.



Oobe Data

802.11n (20MHz)

ANTENNA POLARITY & TEST DISTANCE: HORIZONTAL AT 3 M										
FREQ. (MHz)	EMISSION LEVEL (dBuV/m)	READ LEVEL (dBuV)	LIMIT (dBuV/m)	MARGIN (dB)	ANTENNA FACTOR (dB /m)	CABLE LOSS (dB)	PREAMP FACTOR (dB)	ANTENNA HEIGHT (cm)	TABLE ANGLE (Degree)	REMARK
5617.45	57.48	58.67	68.3	-10.82	37.47	7.62	46.28	100	110	Peak
5963.25	56.59	57.22	68.3	-11.71	37.68	7.97	46.28	100	110	Peak
ANTENNA POLARITY & TEST DISTANCE: VERTICAL AT 3 M										
FREQ. (MHz)	EMISSION LEVEL (dBuV/m)	READ LEVEL (dBuV)	LIMIT (dBuV/m)	MARGIN (dB)	ANTENNA FACTOR (dB /m)	CABLE LOSS (dB)	PREAMP FACTOR (dB)	ANTENNA HEIGHT (cm)	TABLE ANGLE (Degree)	REMARK
5628.38	57.28	58.45	68.3	-11.02	37.48	7.63	46.28	100	110	Peak
5945.68	58.18	58.84	68.3	-10.12	37.67	7.95	46.28	100	110	Peak

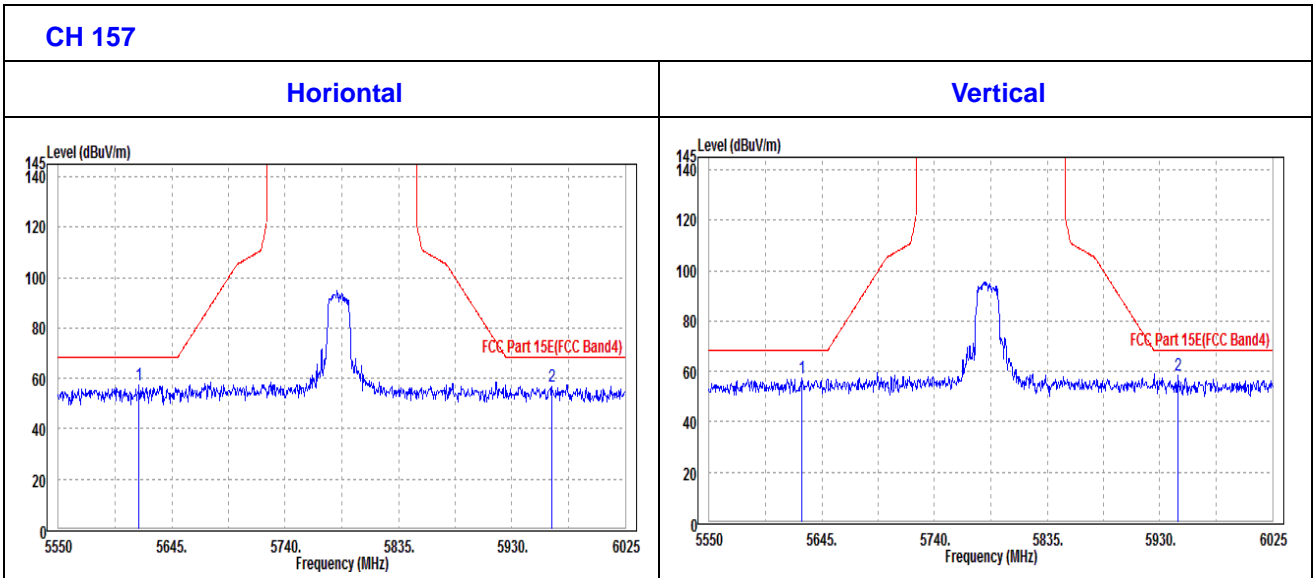



CHANNEL	TX Channel 165	DETECTOR FUNCTION	Peak (PK)
FREQUENCY RANGE	1GHz ~ 40GHz		Average (AV)

ANTENNA POLARITY & TEST DISTANCE: HORIZONTAL AT 3 M										
FREQ. (MHz)	EMISSION LEVEL (dBuV/m)	READ LEVEL (dBuV)	LIMIT (dBuV/m)	MARGIN (dB)	ANTENNA FACTOR (dB /m)	CABLE LOSS (dB)	PREAMP FACTOR (dB)	ANTENNA HEIGHT (cm)	TABLE ANGLE (Degree)	REMARK
5825	93.98	94.83			37.6	7.83	46.28	100	80	Average
5825	104.74	105.59			37.6	7.83	46.28	100	80	Peak
ANTENNA POLARITY & TEST DISTANCE: VERTICAL AT 3 M										
FREQ. (MHz)	EMISSION LEVEL (dBuV/m)	READ LEVEL (dBuV)	LIMIT (dBuV/m)	MARGIN (dB)	ANTENNA FACTOR (dB /m)	CABLE LOSS (dB)	PREAMP FACTOR (dB)	ANTENNA HEIGHT (cm)	TABLE ANGLE (Degree)	REMARK
5825	100.87	101.72			37.6	7.83	46.28	200	120	Average
5825	111.03	111.88			37.6	7.83	46.28	200	120	Peak

REMARKS:

1. Emission Level = Read Level+ Antenna Factor + Cable Loss- Preamp Factor
Margin value = Emission level – Limit value.
2. 5825MHz: Fundamental frequency.



**BUREAU
VERITAS**

Test Report No.: RF180523W002-3

OOBE DATA

802.11n (20MHZ)

ANTENNA POLARITY & TEST DISTANCE: HORIZONTAL AT 3 M										
FREQ. (MHz)	EMISSION LEVEL (dBuV/m)	READ LEVEL (dBuV)	LIMIT (dBuV/m)	MARGIN (dB)	ANTENNA FACTOR (dB /m)	CABLE LOSS (dB)	PREAMP FACTOR (dB)	ANTENNA HEIGHT (cm)	TABLE ANGLE (Degree)	REMARK
5615.55	57.69	58.88	68.3	-10.61	37.47	7.62	46.28	100	110	Peak
5962.3	57.31	57.94	68.3	-10.99	37.68	7.97	46.28	100	110	Peak
ANTENNA POLARITY & TEST DISTANCE: VERTICAL AT 3 M										
FREQ. (MHz)	EMISSION LEVEL (dBuV/m)	READ LEVEL (dBuV)	LIMIT (dBuV/m)	MARGIN (dB)	ANTENNA FACTOR (dB /m)	CABLE LOSS (dB)	PREAMP FACTOR (dB)	ANTENNA HEIGHT (cm)	TABLE ANGLE (Degree)	REMARK
5630.75	57.6	58.77	68.3	-10.7	37.48	7.63	46.28	100	110	Peak
5958.03	57.82	58.46	68.3	-10.48	37.67	7.97	46.28	100	110	Peak

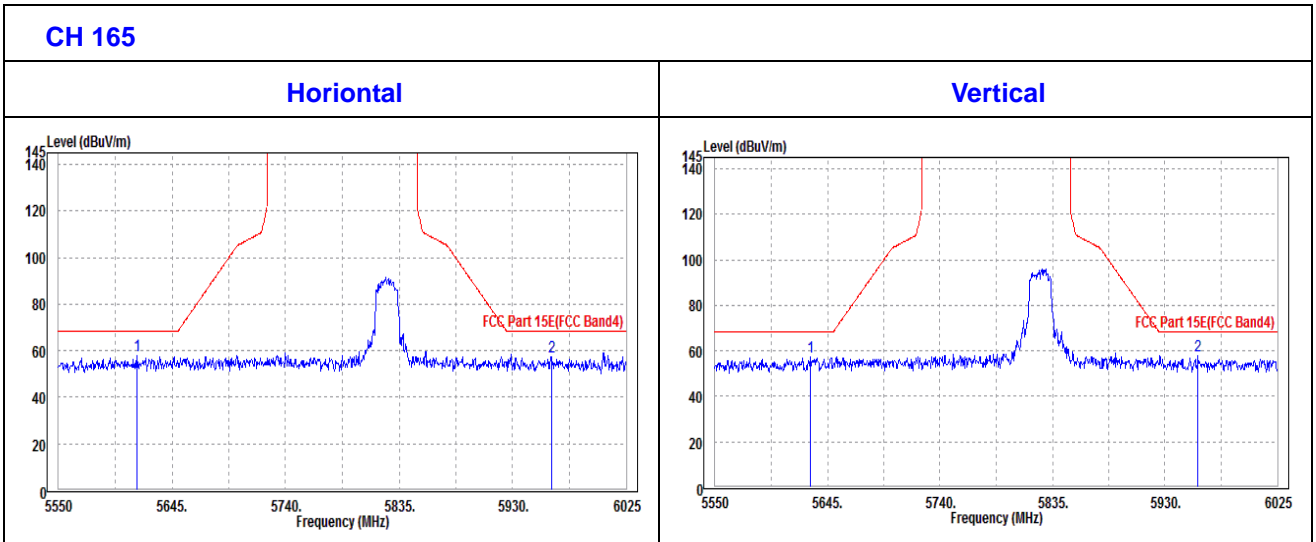



802.11n (40MHz)

CHANNEL	TX Channel 151	DETECTOR FUNCTION	Peak (PK)
FREQUENCY RANGE	1GHz ~ 40GHz		Average (AV)

ANTENNA POLARITY & TEST DISTANCE: HORIZONTAL AT 3 M										
FREQ. (MHz)	EMISSION LEVEL (dBuV/m)	READ LEVEL (dBuV)	LIMIT (dBuV/m)	MARGIN (dB)	ANTENNA FACTOR (dB /m)	CABLE LOSS (dB)	PREAMP FACTOR (dB)	ANTENNA HEIGHT (cm)	TABLE ANGLE (Degree)	REMARK
5755	90.45	91.42			37.55	7.76	46.28	100	100	Average
5755	100.81	101.78			37.55	7.76	46.28	100	100	Peak
ANTENNA POLARITY & TEST DISTANCE: VERTICAL AT 3 M										
FREQ. (MHz)	EMISSION LEVEL (dBuV/m)	READ LEVEL (dBuV)	LIMIT (dBuV/m)	MARGIN (dB)	ANTENNA FACTOR (dB /m)	CABLE LOSS (dB)	PREAMP FACTOR (dB)	ANTENNA HEIGHT (cm)	TABLE ANGLE (Degree)	REMARK
5755	98.37	99.34			37.55	7.76	46.28	200	90	Average
5755	108.08	109.05			37.55	7.76	46.28	200	90	Peak

REMARKS:

1. Emission Level = Read Level+ Antenna Factor + Cable Loss- Preamp Factor
Margin value = Emission level – Limit value.
2. 5755MHz: Fundamental frequency.



**BUREAU
VERITAS**

Test Report No.: RF180523W002-3

OUBE DATA

802.11n (40MHZ)

ANTENNA POLARITY & TEST DISTANCE: HORIZONTAL AT 3 M										
FREQ. (MHz)	EMISSION LEVEL (dBuV/m)	READ LEVEL (dBuV)	LIMIT (dBuV/m)	MARGIN (dB)	ANTENNA FACTOR (dB /m)	CABLE LOSS (dB)	PREAMP FACTOR (dB)	ANTENNA HEIGHT (cm)	TABLE ANGLE (Degree)	REMARK
5614.13	56.87	58.06	68.3	-11.43	37.47	7.62	46.28	100	110	Peak
5960.88	57.35	57.98	68.3	-10.95	37.68	7.97	46.28	100	110	Peak
ANTENNA POLARITY & TEST DISTANCE: VERTICAL AT 3 M										
FREQ. (MHz)	EMISSION LEVEL (dBuV/m)	READ LEVEL (dBuV)	LIMIT (dBuV/m)	MARGIN (dB)	ANTENNA FACTOR (dB /m)	CABLE LOSS (dB)	PREAMP FACTOR (dB)	ANTENNA HEIGHT (cm)	TABLE ANGLE (Degree)	REMARK
5628.38	57.59	58.76	68.3	-10.71	37.48	7.63	46.28	100	110	Peak
5946.15	57.38	58.03	68.3	-10.92	37.67	7.96	46.28	100	110	Peak

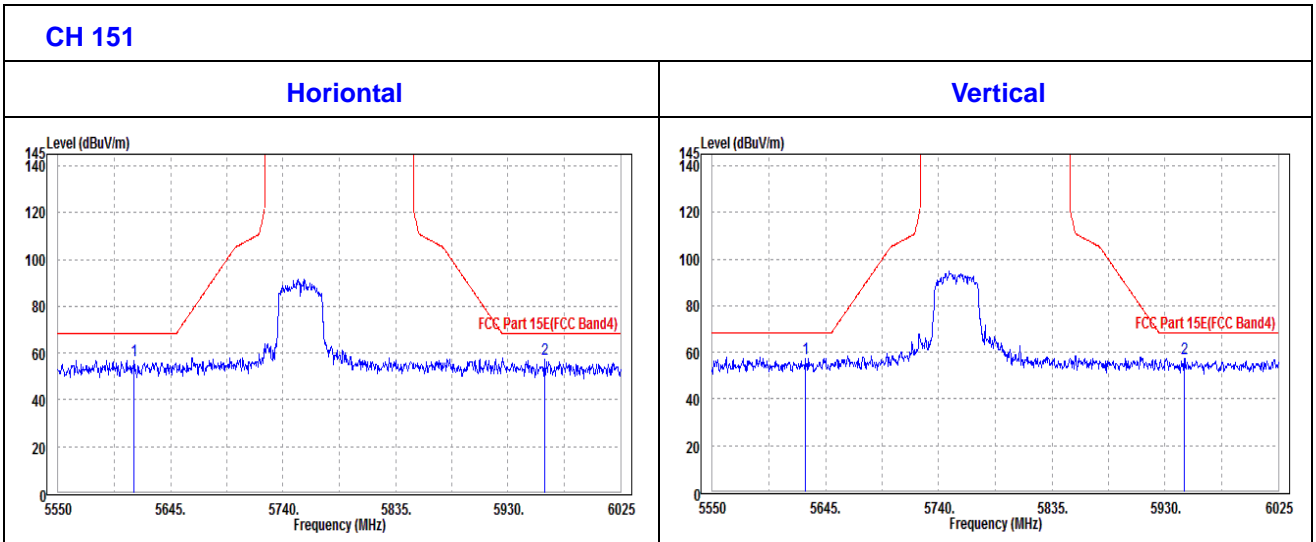



CHANNEL	TX Channel 159	DETECTOR FUNCTION	Peak (PK)
FREQUENCY RANGE	1GHz ~ 40GHz		Average (AV)

ANTENNA POLARITY & TEST DISTANCE: HORIZONTAL AT 3 M										
FREQ. (MHz)	EMISSION LEVEL (dBuV/m)	READ LEVEL (dBuV)	LIMIT (dBuV/m)	MARGIN (dB)	ANTENNA FACTOR (dB /m)	CABLE LOSS (dB)	PREAMP FACTOR (dB)	ANTENNA HEIGHT (cm)	TABLE ANGLE (Degree)	REMARK
5795	89.58	90.48			37.58	7.8	46.28	100	70	Average
5795	98.03	98.93			37.58	7.8	46.28	100	70	Peak
ANTENNA POLARITY & TEST DISTANCE: VERTICAL AT 3 M										
FREQ. (MHz)	EMISSION LEVEL (dBuV/m)	READ LEVEL (dBuV)	LIMIT (dBuV/m)	MARGIN (dB)	ANTENNA FACTOR (dB /m)	CABLE LOSS (dB)	PREAMP FACTOR (dB)	ANTENNA HEIGHT (cm)	TABLE ANGLE (Degree)	REMARK
5795	98.49	99.39			37.58	7.8	46.28	200	70	Average
5795	107.05	107.95			37.58	7.8	46.28	200	70	Peak

REMARKS:

1. Emission Level = Read Level+ Antenna Factor + Cable Loss- Preamp Factor
Margin value = Emission level – Limit value.
2. 5795MHz: Fundamental frequency.



Oobe Data

802.11n (40MHz)

ANTENNA POLARITY & TEST DISTANCE: HORIZONTAL AT 3 M										
FREQ. (MHz)	EMISSION LEVEL (dBuV/m)	READ LEVEL (dBuV)	LIMIT (dBuV/m)	MARGIN (dB)	ANTENNA FACTOR (dB /m)	CABLE LOSS (dB)	PREAMP FACTOR (dB)	ANTENNA HEIGHT (cm)	TABLE ANGLE (Degree)	REMARK
5616.98	56.92	58.11	68.3	-11.38	37.47	7.62	46.28	100	110	Peak
5951.38	56.99	57.64	68.3	-11.31	37.67	7.96	46.28	100	110	Peak
ANTENNA POLARITY & TEST DISTANCE: VERTICAL AT 3 M										
FREQ. (MHz)	EMISSION LEVEL (dBuV/m)	READ LEVEL (dBuV)	LIMIT (dBuV/m)	MARGIN (dB)	ANTENNA FACTOR (dB /m)	CABLE LOSS (dB)	PREAMP FACTOR (dB)	ANTENNA HEIGHT (cm)	TABLE ANGLE (Degree)	REMARK
5608.9	57.63	58.83	68.3	-10.67	37.47	7.61	46.28	100	110	Peak
5948.05	57.54	58.19	68.3	-10.76	37.67	7.96	46.28	100	110	Peak

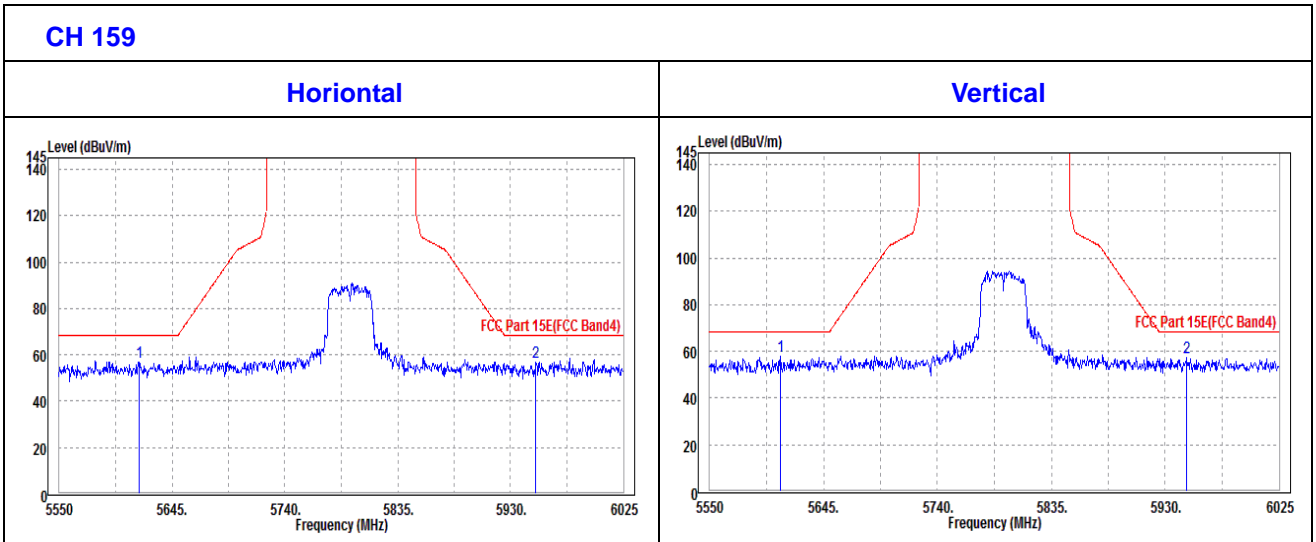



802.11ac (80MHz)

CHANNEL	TX Channel 155	DETECTOR FUNCTION	Peak (PK)
FREQUENCY RANGE	1GHz ~ 40GHz		Average (AV)

ANTENNA POLARITY & TEST DISTANCE: HORIZONTAL AT 3 M										
FREQ. (MHz)	EMISSION LEVEL (dBuV/m)	READ LEVEL (dBuV)	LIMIT (dBuV/m)	MARGIN (dB)	ANTENNA FACTOR (dB /m)	CABLE LOSS (dB)	PREAMP FACTOR (dB)	ANTENNA HEIGHT (cm)	TABLE ANGLE (Degree)	REMARK
5775	84.39	85.32			37.57	7.78	46.28	100	80	Average
5775	92.98	93.91			37.57	7.78	46.28	100	80	Peak
ANTENNA POLARITY & TEST DISTANCE: VERTICAL AT 3 M										
FREQ. (MHz)	EMISSION LEVEL (dBuV/m)	READ LEVEL (dBuV)	LIMIT (dBuV/m)	MARGIN (dB)	ANTENNA FACTOR (dB /m)	CABLE LOSS (dB)	PREAMP FACTOR (dB)	ANTENNA HEIGHT (cm)	TABLE ANGLE (Degree)	REMARK
5775	90.48	91.41			37.57	7.78	46.28	200	110	Average
5775	98.1	99.03			37.57	7.78	46.28	200	110	Peak

REMARKS:

1. Emission Level = Read Level+ Antenna Factor + Cable Loss- Preamp Factor
Margin value = Emission level – Limit value.
2. 5775MHz: Fundamental frequency.



**BUREAU
VERITAS**

Test Report No.: RF180523W002-3

Oobe Data

802.11ac (80MHz)

ANTENNA POLARITY & TEST DISTANCE: HORIZONTAL AT 3 M										
FREQ. (MHz)	EMISSION LEVEL (dBuV/m)	READ LEVEL (dBuV)	LIMIT (dBuV/m)	MARGIN (dB)	ANTENNA FACTOR (dB /m)	CABLE LOSS (dB)	PREAMP FACTOR (dB)	ANTENNA HEIGHT (cm)	TABLE ANGLE (Degree)	REMARK
5614.6	59.03	60.22	68.3	-9.27	37.47	7.62	46.28	100	110	Peak
5961.83	58.8	59.43	68.3	-9.5	37.68	7.97	46.28	100	110	Peak
ANTENNA POLARITY & TEST DISTANCE: VERTICAL AT 3 M										
FREQ. (MHz)	EMISSION LEVEL (dBuV/m)	READ LEVEL (dBuV)	LIMIT (dBuV/m)	MARGIN (dB)	ANTENNA FACTOR (dB /m)	CABLE LOSS (dB)	PREAMP FACTOR (dB)	ANTENNA HEIGHT (cm)	TABLE ANGLE (Degree)	REMARK
5608.9	56.64	57.84	68.3	-11.66	37.47	7.61	46.28	100	110	Peak
5948.05	56.55	57.2	68.3	-11.75	37.67	7.96	46.28	100	110	Peak

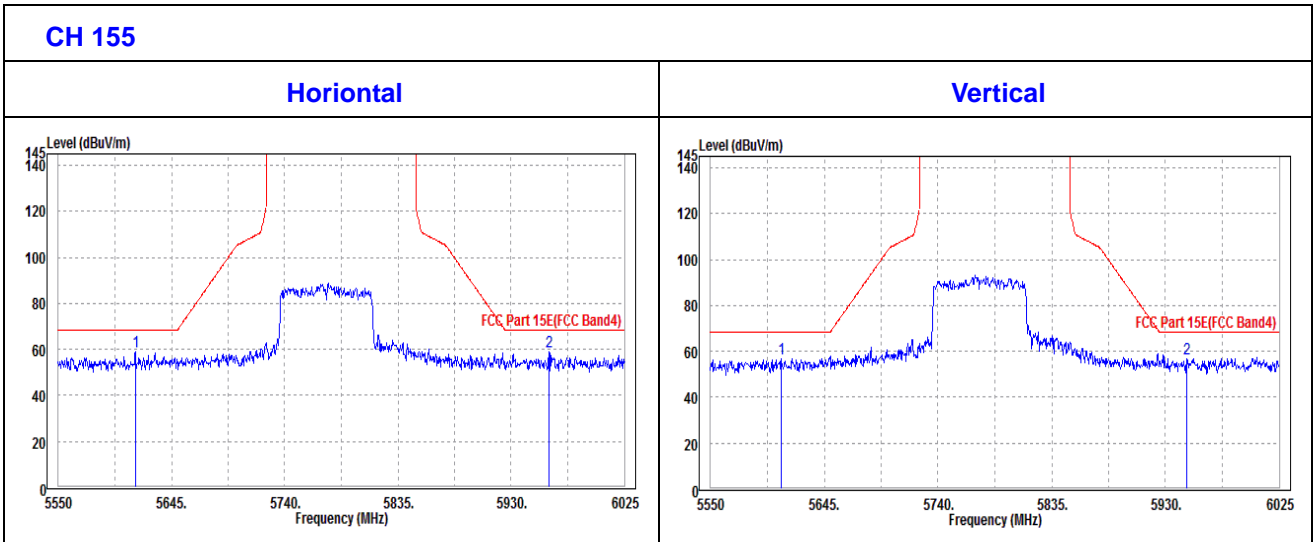



3.2 CONDUCTED EMISSION MEASUREMENT

3.2.1 LIMITS OF CONDUCTED EMISSION MEASUREMENT

FREQUENCY OF EMISSION (MHz)	CONDUCTED LIMIT (dBµV)	
	Quasi-peak	Average
0.15 ~ 0.5	66 to 56	56 to 46
0.5 ~ 5	56	46
5 ~ 30	60	50

- NOTE:**
1. The lower limit shall apply at the transition frequencies.
 2. The limit decreases in line with the logarithm of the frequency in the range of 0.15 to 0.50MHz.
 3. All emanations from a class A/B digital device or system, including any network of conductors and apparatus connected thereto, shall not exceed the level of field strengths specified above.

3.2.2 TEST INSTRUMENTS

Equipment	Manufacturer	Model No.	Serial No.	Last Cal.	Next Cal.
EMI Test Receiver	Rohde&Schwarz	ESR3	101900	Jun. 28,17	Jun. 27,18
EMC32 test software	Rohde&Schwarz	EMC32	NA	NA	NA
LISN network	Rohde&Schwarz	ENV216	101922	Sep. 18,17	Sep. 17,18

- NOTE:**
1. The test was performed in CE shielded room.
 2. The calibration interval of the above test instruments is 12 months. And the calibrations are traceable to CEPREI/CHINA, GRGT/CHINA and NIM/CHINA.

3.2.3 TEST PROCEDURES

- a. The EUT was placed 0.4 meters from the conducting wall of the shielded room with EUT being connected to the power mains through a line impedance stabilization network (LISN). Other support units were connected to the power mains through another LISN. The two LISNs provide 50 ohm/ 50uH of coupling impedance for the measuring instrument.
- b. Both lines of the power mains connected to the EUT were checked for maximum conducted interference.
- c. The frequency range from 150kHz to 30MHz was searched. Emission levels under (Limit - 20dB) was not recorded.

NOTE: All modes of operation were investigated and the worst-case emissions are reported.



3.2.4 DEVIATION FROM TEST STANDARD

No deviation.

3.2.5 TEST SETUP

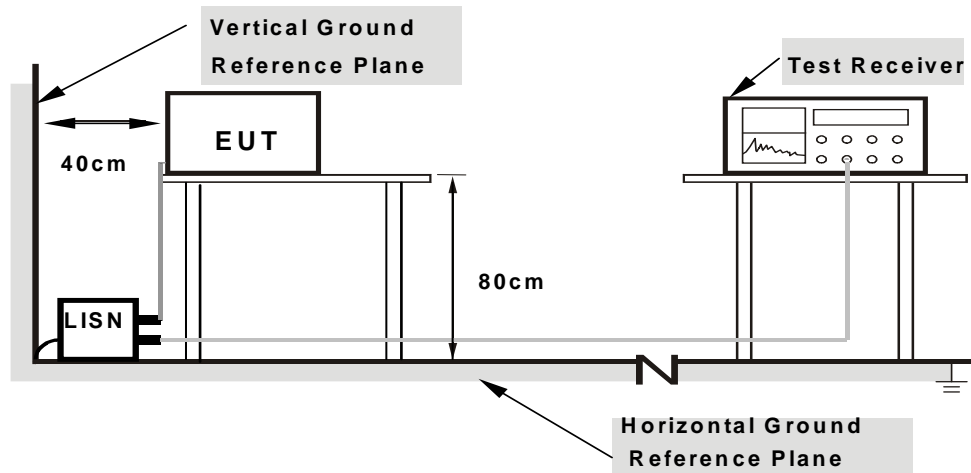

- Note:**
- 1.Support units were connected to second LISN.
 - 2.Both of LISNs (AMN) are 80 cm from EUT and at least 80 cm from other units and other metal planes

For the actual test configuration, please refer to the attached file (Test Setup Photo).

3.2.6 EUT OPERATING CONDITIONS

Same as 3.1.6.



3.2.7 TEST RESULTS

CONDUCTED WORST-CASE DATA :

Frequency Range	150KHz ~ 30MHz	Detector Function & Resolution Bandwidth	Quasi-Peak (QP) / Average (AV), 9 kHz
Input Power	120Vac, 60Hz	Environmental Conditions	24deg. C, 55RH
Tested By	John Wen	TEST DATE	2018/06/07

Frequency (MHz)	QuasiPeak (dB μ V)	CAverage (dB μ V)	Limit (dB μ V)	Margin (dB)	Line	Filter	Corr. (dB)
0.170000	---	44.58	54.96	-10.38	L1	ON	9.7
0.170000	56.48	---	64.96	-8.48	L1	ON	9.7
0.252000	---	34.23	51.69	-17.46	L1	ON	9.7
0.252000	49.99	---	61.69	-11.70	L1	ON	9.7
0.500000	---	26.82	46.00	-19.18	L1	ON	9.7
0.500000	38.23	---	56.00	-17.77	L1	ON	9.7
0.876000	---	30.29	46.00	-15.71	L1	ON	9.7
0.876000	42.57	---	56.00	-13.43	L1	ON	9.7
1.592000	---	29.48	46.00	-16.52	L1	ON	9.7
1.592000	40.51	---	56.00	-15.49	L1	ON	9.7
3.016000	---	30.16	46.00	-15.84	L1	ON	9.7
3.016000	40.44	---	56.00	-15.56	L1	ON	9.7

- REMARKS:**
1. Q.P. and AV. are abbreviations of quasi-peak and average individually.
 2. "-": The Quasi-peak reading value also meets average limit and measurement with the average detector is unnecessary.
 3. The emission levels of other frequencies were very low against the limit.
 4. Margin value = Emission level - Limit value
 5. Correction factor = Insertion loss + Cable loss
 6. Emission Level = Correction Factor + Reading Value.

Full Spectrum

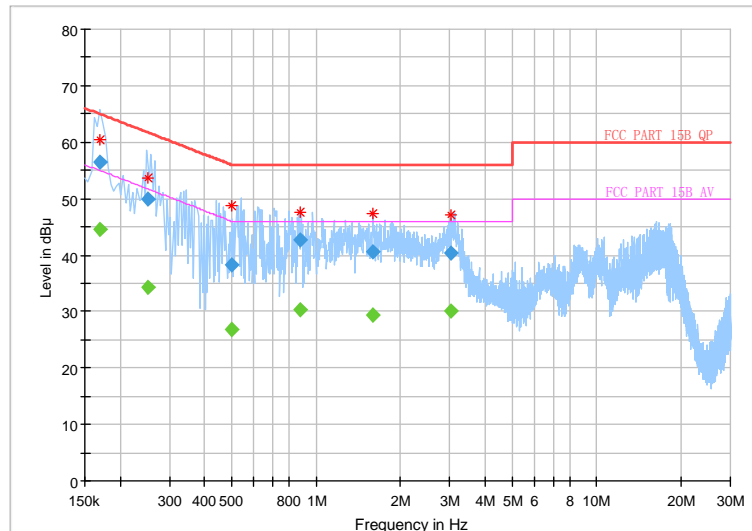



Frequency Range	150KHz ~ 30MHz	Detector Function & Resolution Bandwidth	Quasi-Peak (QP) / Average (AV), 9 kHz
Input Power	120Vac, 60Hz	Environmental Conditions	24deg. C, 55RH
Tested By	John Wen	TEST DATE	2018/06/07

Frequency (MHz)	QuasiPeak (dBµV)	CAverage (dBµV)	Limit (dBµV)	Margin (dB)	Line	Filter	Corr. (dB)
0.432000	---	34.11	47.21	-13.10	N	ON	10.1
0.432000	43.70	---	57.21	-13.51	N	ON	10.1
0.520000	---	33.81	46.00	-12.19	N	ON	10.1
0.520000	42.83	---	56.00	-13.17	N	ON	10.1
0.792000	---	31.40	46.00	-14.60	N	ON	10.0
0.792000	42.94	---	56.00	-13.06	N	ON	10.0
1.734000	---	30.90	46.00	-15.10	N	ON	9.8
1.734000	41.74	---	56.00	-14.26	N	ON	9.8
3.064000	---	34.69	46.00	-11.31	N	ON	9.8
3.064000	43.60	---	56.00	-12.40	N	ON	9.8
16.432000	---	37.40	50.00	-12.60	N	ON	10.0
16.432000	45.84	---	60.00	-14.16	N	ON	10.0

- REMARKS:**
1. Q.P. and AV. are abbreviations of quasi-peak and average individually.
 2. "-": The Quasi-peak reading value also meets average limit and measurement with the average detector is unnecessary.
 3. The emission levels of other frequencies were very low against the limit.
 4. Margin value = Emission level - Limit value
 5. Correction factor = Insertion loss + Cable loss
 6. Emission Level = Correction Factor + Reading Value.

Full Spectrum

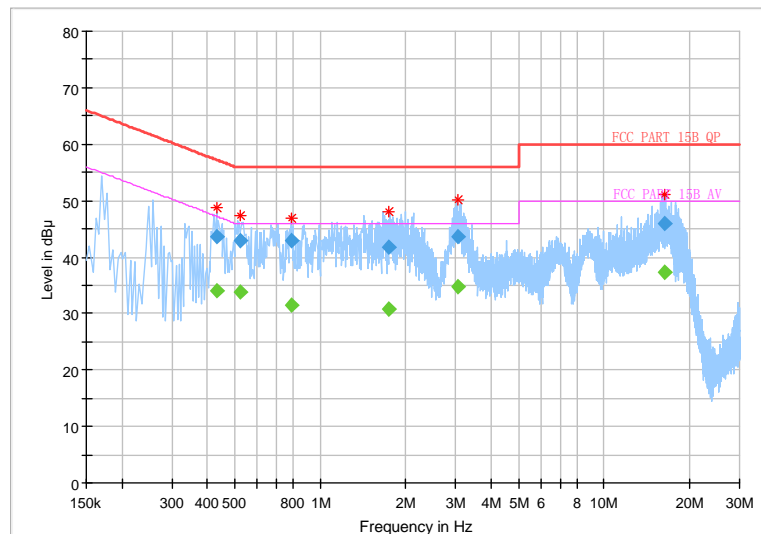



3.3 MAXIMUM CONDUCTED OUTPUT POWER MEASUREMENT

3.3.1 LIMITS OF MAXIMUM CONDUCTED OUTPUT POWER MEASUREMENT

Operation Band	EUT Category		LIMIT
U-NII-1		Outdoor Access Point	1 Watt (30 dBm) (Max. e.i.r.p \cong 125mW(21 dBm) at any elevation angle above 30 degrees as measured from the horizon)
		Fixed point-to-point Access Point	1 Watt (30 dBm)
		Indoor Access Point	1 Watt (30 dBm)
	√	Client devices	250mW (24 dBm)
U-NII-2A		√	250mW (24 dBm) or 11 dBm+10 log B*
U-NII-2C		√	250mW (24 dBm) or 11 dBm+10 log B*
U-NII-3		√	1 Watt (30 dBm)

NOTE: Where B is the 26dB emission bandwidth in MHz.



3.3.2 TEST SETUP

FOR POWER OUTPUT MEASUREMENT

802.11a, 802.11n (20MHz), 802.11n (40MHz) TEST CONFIGURATION

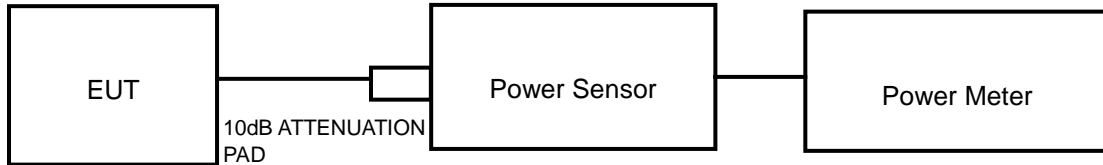

11ac TEST CONFIGURATION

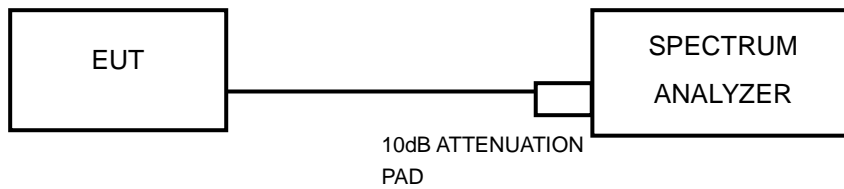

FOR 26dB BANDWIDTH

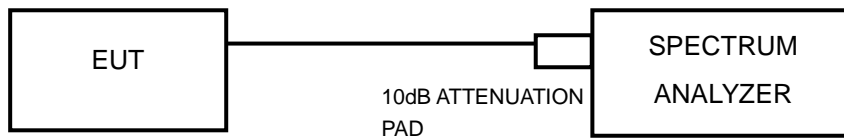

3.3.3 TEST INSTRUMENTS

Equipment	Manufacturer	Model No.	Serial No.	Last Cal.	Next Cal.
Power Meter	ANRITSU	ML2495A	1506002	Mar. 02,18	Mar. 01,19
EXA Signal Analyzer	KEYSIGHT	N9010A-526	MY54510523	Jun. 28,17	Jun. 27,18
EXA Signal Analyzer	KEYSIGHT	N9010A-544	MY54510332	Mar. 16,18	Mar. 15,19
Power Sensor	ANRITSU	MA2411B	1339352	Mar. 16,18	Mar. 15,19

NOTE:

1. The calibration interval of the above test instruments is 12 months and the calibrations are traceable to CEPREI/CHINA, GRGT/CHINA and NIM/CHINA.
2. The test was performed in RF Oven room.

3.3.4 TEST PROCEDURE

FOR POWER MEASUREMENT

For 802.11a, 802.11n (20MHz), 802.11n (40MHz)

Method PM is used to perform output power measurement, trigger and gating function of wide band power meter is enabled to measure max output power of TX on burst. Duty factor is not added to measured value.

For 802.11ac (80MHz)

1. Measure the duty cycle, x , of the transmitter output signal as described in II.B.
2. Set span to encompass the EBW (or, alternatively, the entire 99% occupied bandwidth) of the signal.
3. Set RBW = 1 MHz.
4. Set VBW \geq 3 MHz.
5. Number of points in sweep $\geq 2 \times \text{span} / \text{RBW}$. (This ensures that bin-to-bin spacing is $\leq \text{RBW}/2$, so that narrowband signals are not lost between frequency bins.)
6. Sweep time = auto.
7. Detector = power averaging (rms), if available. Otherwise, use sample detector mode.
8. Do not use sweep triggering. Allow the sweep to “free run.”
9. Trace average at least 100 traces in power averaging (rms) mode; however, the number of traces to be averaged shall be increased above 100 as needed to ensure that the average accurately represents the true average over the on and off periods of the transmitter.
10. Add $10 \log (1/x)$, where x is the duty cycle, to the measured power to compute the average power during the actual transmission times (because the measurement represents an average over both the on and off times of the transmission). For example, add $10 \log (1/0.25) = 6 \text{ dB}$ if the duty cycle is 25%.



FOR 99 PERCENT OCCUPIED BANDWIDTH

The following procedure shall be used for measuring (99 %) power bandwidth:

1. Set center frequency to the nominal EUT channel center frequency.
2. Set span = 1.5 times to 5.0 times the OBW.
3. Set RBW = 1 % to 5 % of the OBW
4. Set VBW $\geq 3 \cdot$ RBW
5. Video averaging is not permitted. Where practical, a sample detection and single sweep mode shall be used. Otherwise, peak detection and max hold mode (until the trace stabilizes) shall be used.
6. Use the 99 % power bandwidth function of the instrument (if available).
7. If the instrument does not have a 99 % power bandwidth function, the trace data points are recovered and directly summed in power units. The recovered amplitude data points, beginning at the lowest frequency, are placed in a running sum until 0.5 % of the total is reached; that frequency is recorded as the lower frequency. The process is repeated until 99.5 % of the total is reached; that frequency is recorded as the upper frequency. The 99% occupied bandwidth is the difference between these two frequencies.

FOR 26dB BANDWIDTH

- 1) Set RBW = approximately 1% of the emission bandwidth.
- 2) Set the VBW > RBW.
- 3) Detector = Peak.
- 4) Trace mode = max hold.
- 5) Measure the maximum width of the emission that is 26 dB down from the peak of the emission. Compare this with the RBW setting of the analyzer. Readjust RBW and repeat measurement as needed until the RBW/EBW ratio is approximately 1%.

FOR 6dB BANDWIDTH

1. Set RBW = 100 kHz.
2. Set the video bandwidth (VBW) ≥ 3 RBW.
3. Detector = Peak.
4. Trace mode = max hold.
5. Sweep = auto couple.
6. Allow the trace to stabilize.
7. Measure the maximum width of the emission that is constrained by the frequencies associated with the two outermost amplitude points (upper and lower frequencies) that are attenuated by 6 dB relative to the maximum level measured in the fundamental emission.



Test Report No.: RF180523W002-3

3.3.5 DEVIATION FROM TEST STANDARD

No deviation.

3.3.6 EUT OPERATING CONDITIONS

The software provided by client to enable the EUT under transmission condition continuously at specific channel frequencies individually.



3.3.7 TEST RESULTS

OUTPUT POWER:

802.11a

CHANNEL	CHANNEL FREQUENCY (MHz)	AVERAGE POWER (dBm)	AVERAGE POWER (mW)	POWER LIMIT (dBm)	PASS/FAIL
36	5180	15.01	31.696	24	PASS
40	5200	15.10	32.359	24	PASS
48	5240	14.97	31.405	24	PASS
52	5260	14.78	30.061	24	PASS
60	5300	14.17	26.122	24	PASS
64	5320	14.06	25.468	24	PASS
100	5500	15.00	31.623	24	PASS
116	5580	16.05	40.272	24	PASS
140	5700	16.12	40.926	24	PASS
149	5745	15.57	36.058	30	PASS
157	5785	15.38	34.514	30	PASS
165	5825	15.18	32.961	30	PASS

802.11n (20MHz)

CHANNEL	CHANNEL FREQUENCY (MHz)	AVERAGE POWER (dBm)	AVERAGE POWER (mW)	POWER LIMIT (dBm)	PASS/FAIL
36	5180	15.45	35.075	24	PASS
40	5200	15.02	31.769	24	PASS
48	5240	14.64	29.107	24	PASS
52	5260	14.52	28.314	24	PASS
60	5300	14.31	26.977	24	PASS
64	5320	13.82	24.099	24	PASS
100	5500	15.22	33.266	24	PASS
116	5580	16.07	40.458	24	PASS
140	5700	16.08	40.551	24	PASS
149	5745	15.41	34.754	30	PASS
157	5785	15.31	33.963	30	PASS
165	5825	14.85	30.549	30	PASS



802.11n (40MHz)

CHANNEL	CHANNEL FREQUENCY (MHz)	AVERAGE POWER (dBm)	AVERAGE POWER (mW)	POWER LIMIT (dBm)	PASS/FAIL
38	5190	15.10	32.359	24	PASS
46	5230	14.97	31.405	24	PASS
54	5270	14.99	31.550	24	PASS
62	5310	13.66	23.227	24	PASS
102	5510	14.76	29.923	24	PASS
110	5550	14.79	30.130	24	PASS
134	5670	15.48	35.318	24	PASS
151	5755	15.15	32.734	30	PASS
165	5825	15.55	35.892	30	PASS

802.11ac (80MHz)

CHANNEL	CHANNEL FREQUENCY (MHz)	AVERAGE POWER w/o Duty Factor (dBm)	Duty Factor	AVERAGE POWER with Duty Factor (dBm)	AVERAGE POWER (mW)	POWER LIMIT (dBm)	PASS/FAIL
42	5210	14.02	0.48	14.50	28.184	24	PASS
58	5290	13.57	0.48	14.05	25.410	24	PASS
106	5530	14.27	0.48	14.75	29.854	24	PASS
155	5775	14.67	0.48	15.15	32.734	30	PASS



99% OCCUPIED BANDWIDTH & 26dB BANDWIDTH/6dB BANDWIDTH:

802.11a

CHANNEL	CHANNEL FREQUENCY (MHz)	99% OCCUPIED BANDWIDTH	26dB BANDWIDTH (MHz)	PASS/FAIL
36	5180	16.50	20.19	PASS
40	5200	16.56	19.10	PASS
48	5240	16.62	20.08	PASS
52	5260	16.74	20.15	PASS
60	5300	16.68	20.21	PASS
64	5320	16.56	20.04	PASS
100	5500	16.56	20.53	PASS
116	5580	16.86	20.43	PASS
140	5700	16.50	20.24	PASS
CHANNEL	CHANNEL FREQUENCY (MHz)	99% OCCUPIED BANDWIDTH	6dB BANDWIDTH (MHz)	PASS/FAIL
149	5745	16.44	16.31	PASS
157	5785	16.68	16.29	PASS
165	5825	16.56	15.94	PASS



802.11n (20MHz)

CHANNEL	CHANNEL FREQUENCY (MHz)	99% OCCUPIED BANDWIDTH	26dB BANDWIDTH (MHz)	PASS/FAIL
36	5180	17.64	20.35	PASS
40	5200	17.64	20.29	PASS
48	5240	17.58	20.43	PASS
52	5260	17.64	20.34	PASS
60	5300	17.58	20.62	PASS
64	5320	17.64	20.55	PASS
100	5500	17.64	20.45	PASS
116	5580	17.70	20.71	PASS
140	5700	17.64	20.57	PASS
CHANNEL	CHANNEL FREQUENCY (MHz)	99% OCCUPIED BANDWIDTH	6dB BANDWIDTH (MHz)	PASS/FAIL
149	5745	17.52	17.29	PASS
157	5785	17.70	17.55	PASS
165	5825	17.70	17.33	PASS



802.11n (40MHz)

CHANNEL	CHANNEL FREQUENCY (MHz)	99% OCCUPIED BANDWIDTH	26dB BANDWIDTH (MHz)	PASS/FAIL
38	5190	36.06	41.35	PASS
46	5230	36.00	41.41	PASS
54	5270	36.06	41.30	PASS
62	5310	36.18	41.52	PASS
102	5510	36.18	42.14	PASS
110	5550	36.12	41.73	PASS
134	5670	36.12	41.33	PASS
CHANNEL	CHANNEL FREQUENCY (MHz)	99% OCCUPIED BANDWIDTH	6dB BANDWIDTH (MHz)	PASS/FAIL
151	5755	35.94	34.66	PASS
159	5795	36.06	34.44	PASS

802.11ac (80MHz)

CHANNEL	CHANNEL FREQUENCY (MHz)	99% OCCUPIED BANDWIDTH	26dB BANDWIDTH (MHz)	PASS/FAIL
42	5210	75.60	81.73	PASS
58	5290	75.60	81.72	PASS
106	5530	75.72	83.06	PASS
CHANNEL	CHANNEL FREQUENCY (MHz)	99% OCCUPIED BANDWIDTH	6dB BANDWIDTH (MHz)	PASS/FAIL
155	5775	75.84	76.47	PASS



BUREAU VERITAS

Test Report No.: RF180523W002-3

For U-NII-1:

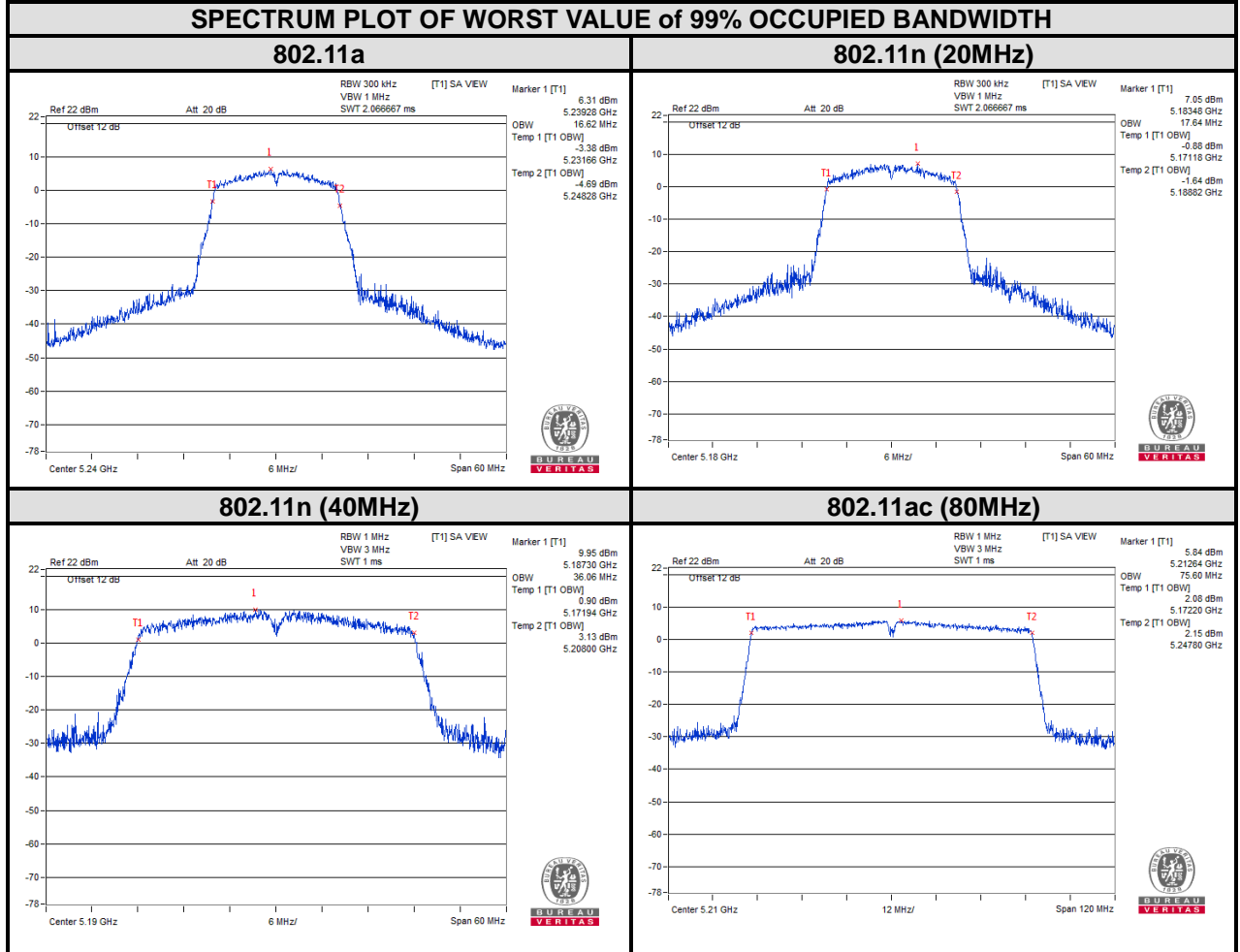



BUREAU VERITAS

Test Report No.: RF180523W002-3

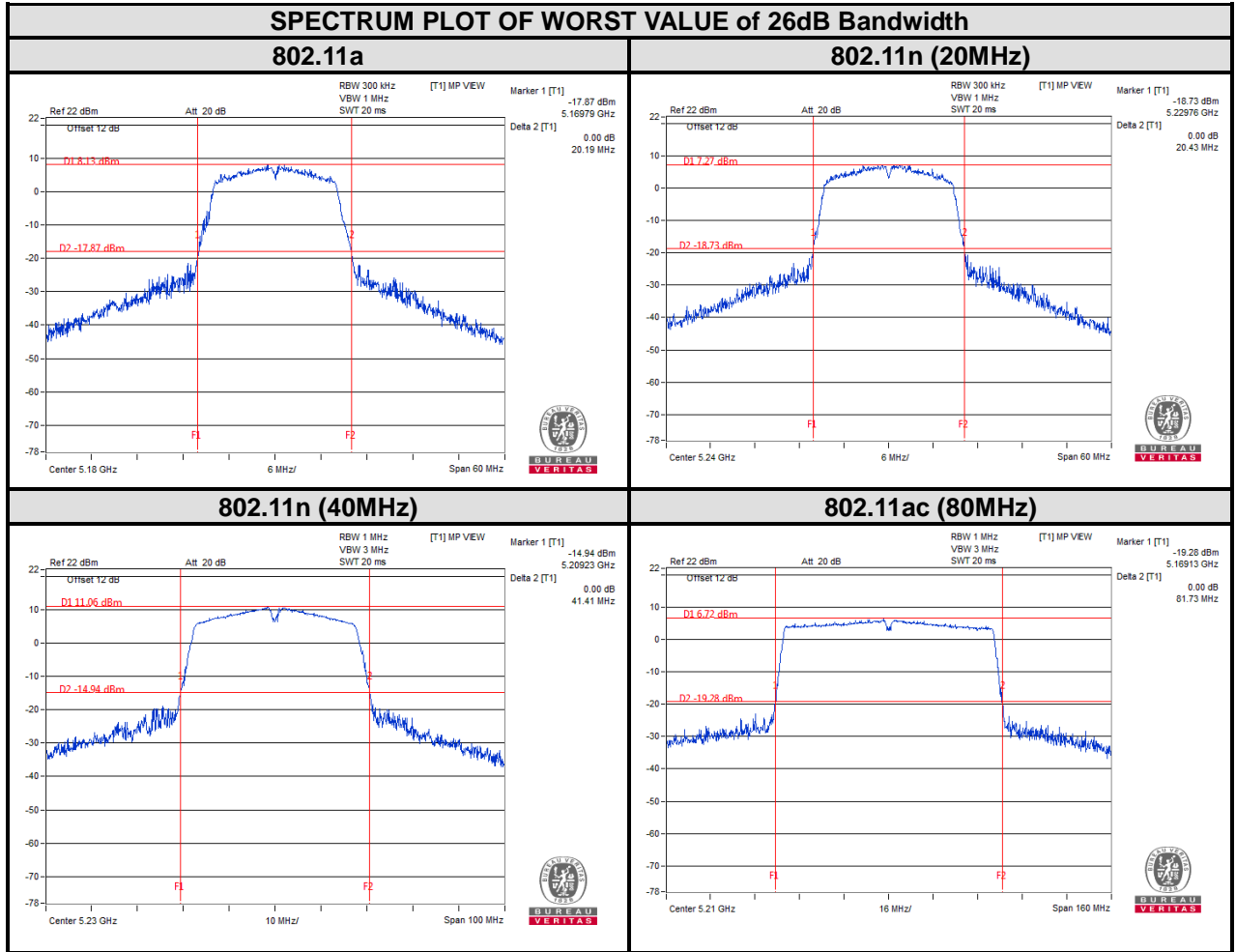



BUREAU VERITAS

Test Report No.: RF180523W002-3

For U-NII-2A:

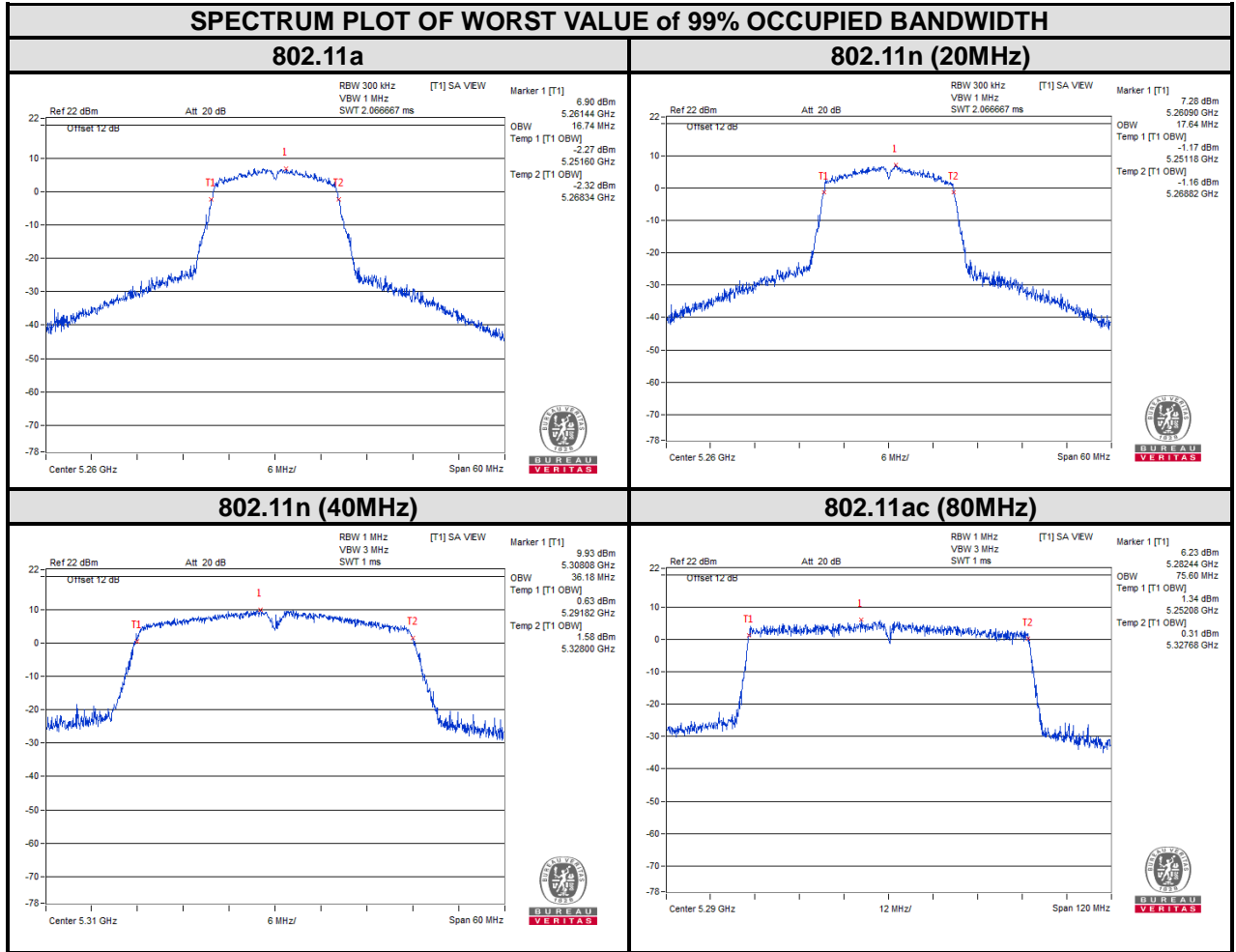



BUREAU VERITAS

Test Report No.: RF180523W002-3

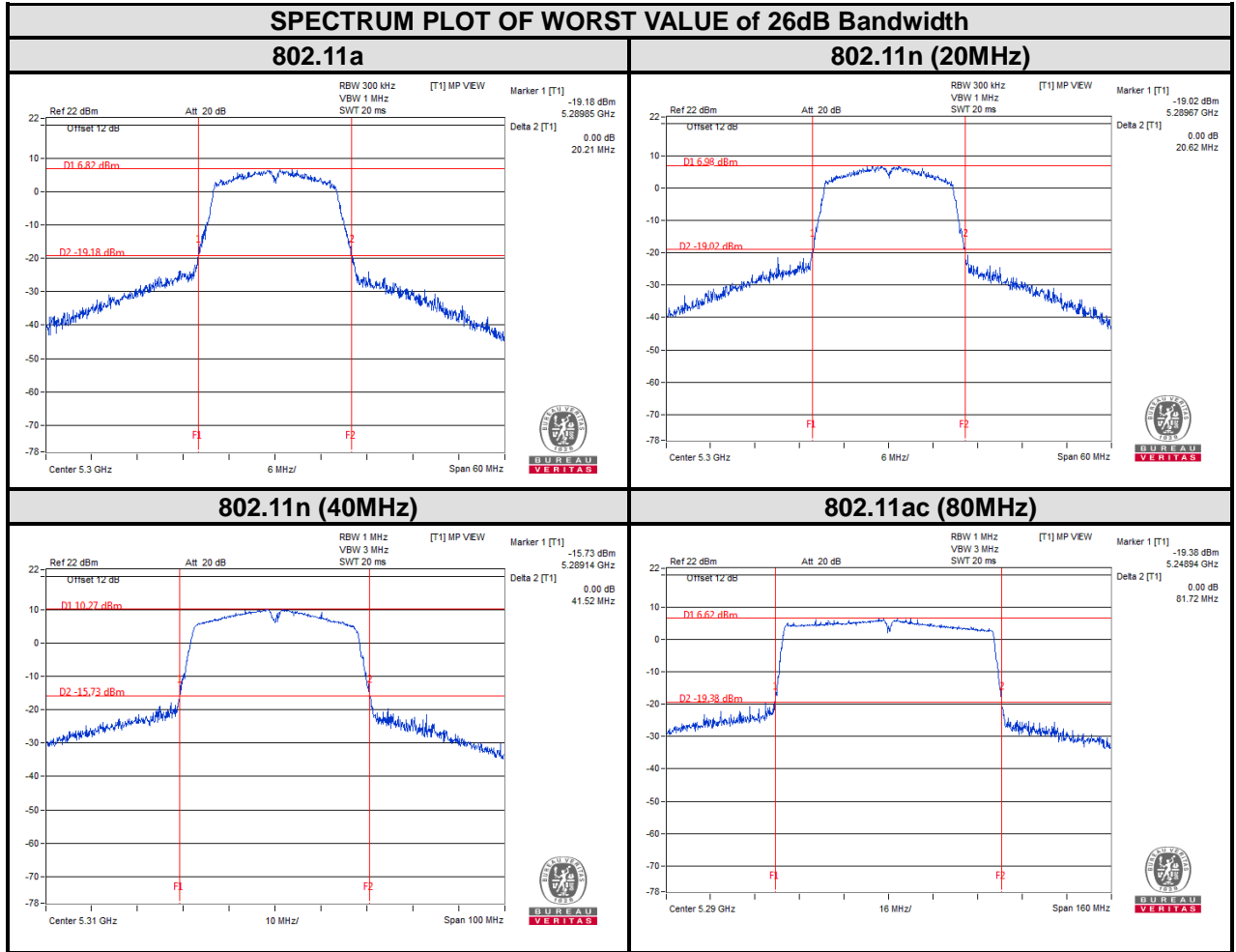



BUREAU VERITAS

Test Report No.: RF180523W002-3

For U-NII-2C:

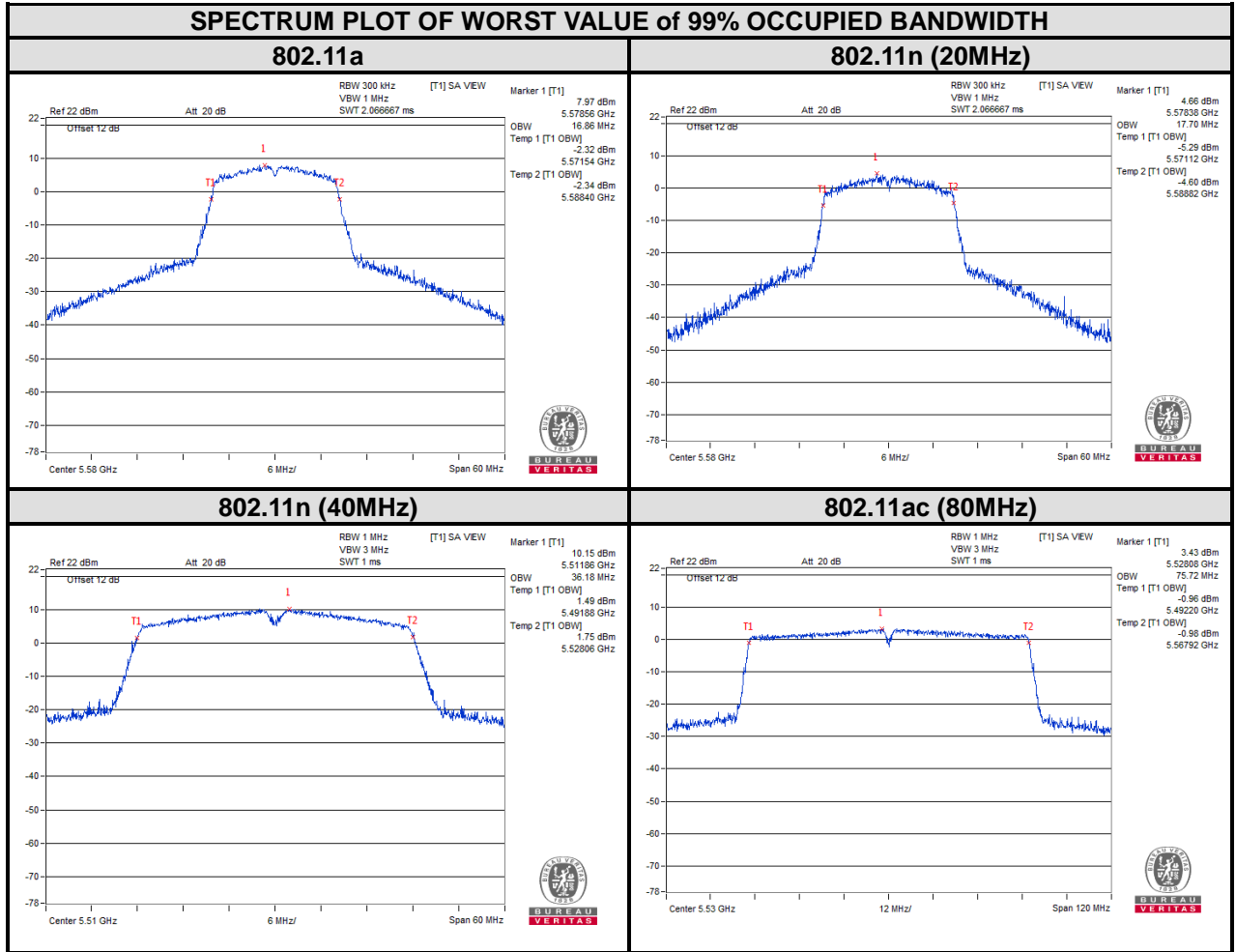

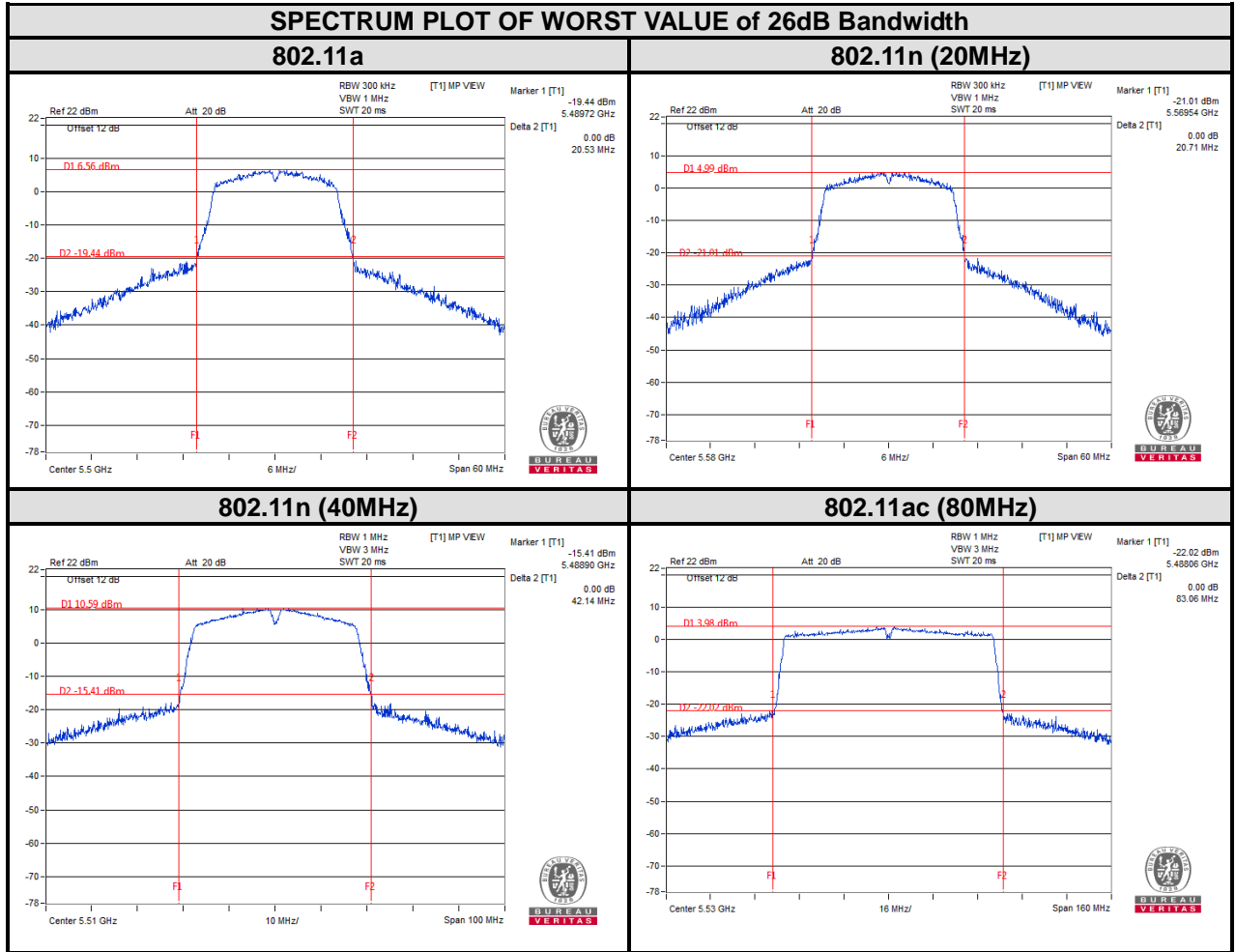



BUREAU VERITAS

Test Report No.: RF180523W002-3

For U-NII-3:

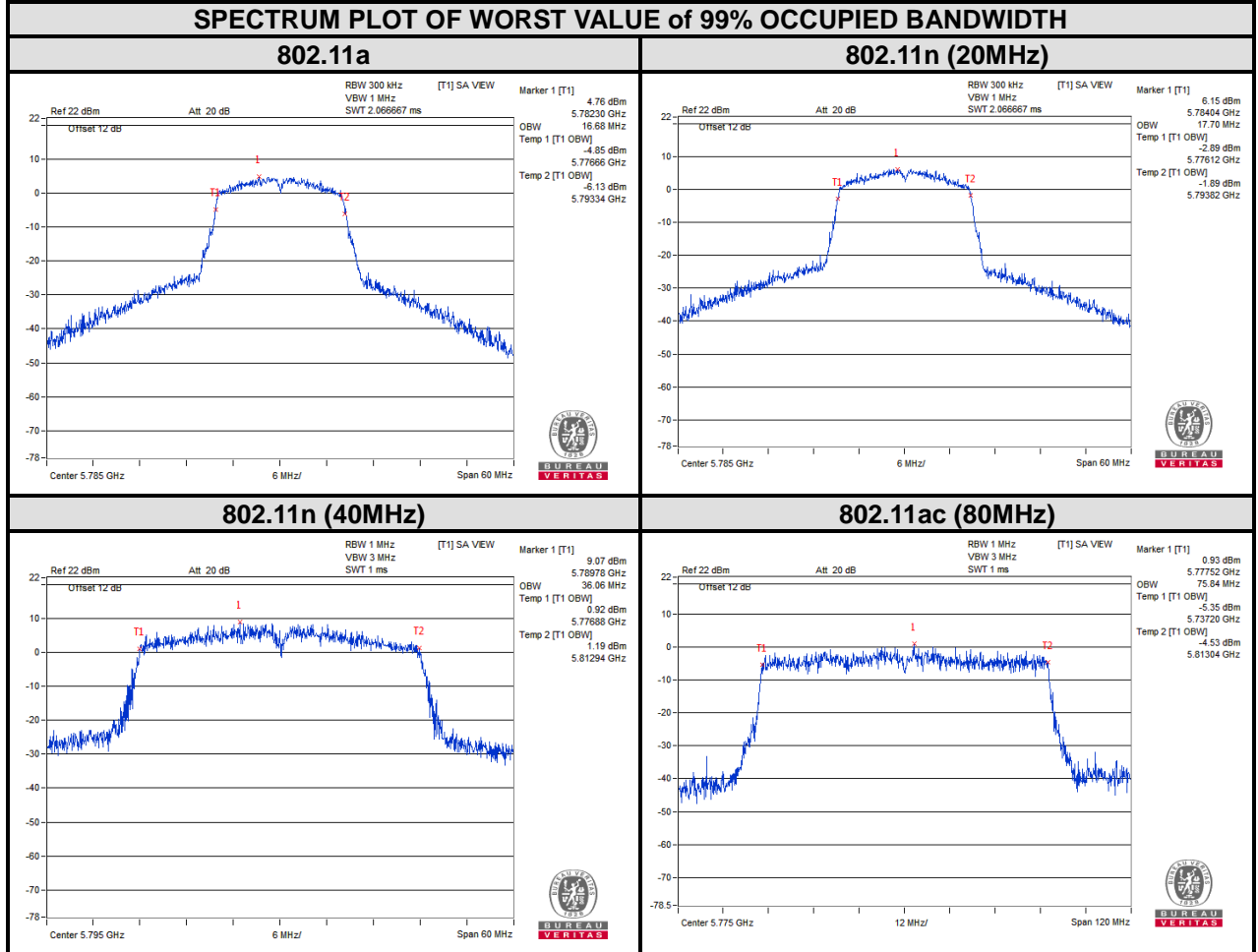



BUREAU VERITAS

Test Report No.: RF180523W002-3

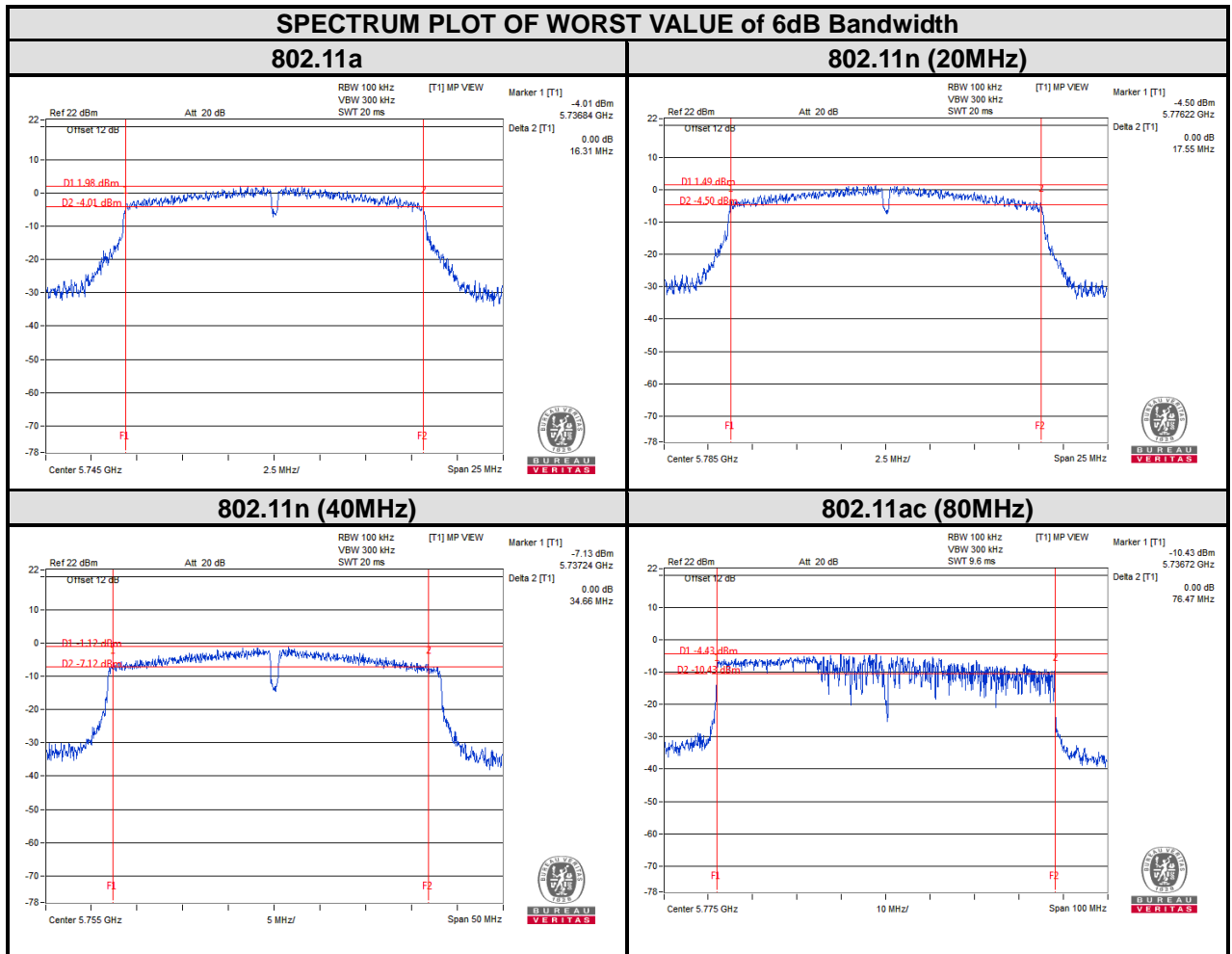



3.4 MAXIMUM POWER SPECTRAL DENSITY MEASUREMENT

3.4.1 LIMITS OF MAXIMUM POWER SPECTRAL DENSITY MEASUREMENT

Operation Band	EUT Category		LIMIT
U-NII-1		Outdoor Access Point	17dBm/ MHz
		Fixed point-to-point Access Point	
		Indoor Access Point	
	√	Client devices	11dBm/ MHz
U-NII-2A		√	11dBm/ MHz
U-NII-2C		√	11dBm/ MHz
U-NII-3		√	30dBm/ 500kHz

3.4.2 TEST SETUP

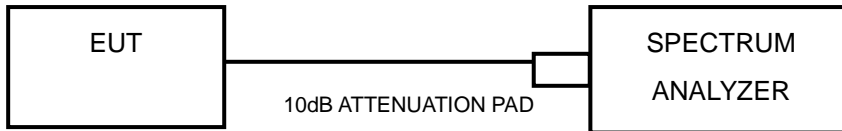

3.4.3 TEST INSTRUMENTS

Refer to section 3.3.3 to get information of above instrument.



3.4.4 TEST PROCEDURES

Using method SA-2

- 1) Set span to encompass the entire emission bandwidth (EBW) of the signal.
- 2) Set RBW = 1 MHz, Set VBW \geq 3 MHz, Detector = RMS
- 3) Set Channel power measure = 1MHz
- 4) Sweep time = auto, trigger set to "free run".
- 5) Trace average at least 100 traces in power averaging mode.
- 6) Add $10 \log(1/x)$, where x is the duty cycle, to the measured power in order to compute the average power during the actual transmission times (because the measurement represents an average over both the on and off times of the transmission).
- 7) Record the max value

3.4.5 DEVIATION FROM TEST STANDARD

No deviation.

3.4.6 EUT OPERATING CONDITIONS

Same as 3.1.6.



3.4.7 TEST RESULTS

For U-NII-1 & U-NII-2A & U-NII-2C :

802.11a

CHANNEL	FREQUENCY (MHz)	PSD w/o Duty Factor (dBm/MHz)	Duty Factor	PSD with Duty Factor (dBm/MHz)	MAXIMUM LIMIT (dBm/MHz)	PASS/FAIL
36	5180	4.56	0.12	4.68	11	PASS
40	5200	3.37	0.12	3.49	11	PASS
48	5240	3.19	0.12	3.31	11	PASS
52	5260	3.87	0.12	3.99	11	PASS
60	5300	3.44	0.12	3.56	11	PASS
64	5320	3.33	0.12	3.45	11	PASS
100	5500	3.62	0.12	3.74	11	PASS
116	5580	4.78	0.12	4.9	11	PASS
140	5700	4.67	0.12	4.79	11	PASS

802.11n (20MHz)

CHANNEL	FREQUENCY (MHz)	PSD w/o Duty Factor (dBm/MHz)	Duty Factor	PSD with Duty Factor (dBm/MHz)	MAXIMUM LIMIT (dBm/MHz)	PASS/FAIL
36	5180	4.46	0.19	4.65	11	PASS
40	5200	3.26	0.19	3.45	11	PASS
48	5240	3.95	0.19	4.14	11	PASS
52	5260	4.29	0.19	4.48	11	PASS
60	5300	3.67	0.19	3.86	11	PASS
64	5320	2.81	0.19	3.00	11	PASS
100	5500	3.99	0.19	4.18	11	PASS
116	5580	1.78	0.19	1.97	11	PASS
140	5700	2.35	0.19	2.54	11	PASS



802.11n (40MHz)

CHANNEL	FREQUENCY (MHz)	PSD w/o Duty Factor (dBm/MHz)	Duty Factor	PSD with Duty Factor (dBm/MHz)	MAXIMUM LIMIT (dBm/MHz)	PASS/FAIL
38	5190	1.19	0.25	1.44	11	PASS
46	5230	1.43	0.25	1.68	11	PASS
54	5270	1.02	0.25	1.27	11	PASS
62	5310	1.06	0.25	1.31	11	PASS
102	5510	1.29	0.25	1.54	11	PASS
110	5550	1.16	0.25	1.41	11	PASS
134	5670	1.52	0.25	1.77	11	PASS

802.11ac (80MHz)

CHANNEL	FREQUENCY (MHz)	PSD w/o Duty Factor (dBm/MHz)	Duty Factor	PSD with Duty Factor (dBm/MHz)	MAXIMUM LIMIT (dBm/MHz)	PASS/FAIL
42	5210	5.24	0.48	5.72	11	PASS
58	5290	5.11	0.48	5.59	11	PASS
106	5530	2.36	0.48	2.84	11	PASS



For U-NII-3:

802.11a

CHANNEL	FREQUENCY (MHz)	PSD w/o Duty Factor (dBm/MHz)	PSD w/o Duty Factor (dBm/500kHz)	Duty Factor	PSD with Duty Factor (dBm/500kHz)	LIMIT (dBm/500kHz)	PASS /FAIL
149	5745	13.42	10.41	0.12	10.53	30	PASS
157	5785	11.60	8.59	0.12	8.71	30	PASS
165	5825	12.74	9.73	0.12	9.85	30	PASS

802.11n (20MHz)

CHANNEL	FREQUENCY (MHz)	PSD w/o Duty Factor (dBm/MHz)	PSD w/o Duty Factor (dBm/500kHz)	Duty Factor	PSD with Duty Factor (dBm/500kHz)	LIMIT (dBm/500kHz)	PASS /FAIL
149	5745	13.72	10.71	0.19	10.90	30	PASS
157	5785	12.97	9.96	0.19	10.15	30	PASS
165	5825	12.40	9.39	0.19	9.58	30	PASS

802.11n (40MHz)

CHANNEL	FREQUENCY (MHz)	PSD w/o Duty Factor (dBm/MHz)	PSD w/o Duty Factor (dBm/500kHz)	Duty Factor	PSD with Duty Factor (dBm/500kHz)	LIMIT (dBm/500kHz)	PASS /FAIL
151	5755	10.09	7.08	0.25	7.33	30	PASS
159	5795	9.84	6.83	0.25	7.08	30	PASS

802.11ac (80MHz)

CHANNEL	FREQUENCY (MHz)	PSD w/o Duty Factor (dBm/MHz)	PSD w/o Duty Factor (dBm/500kHz)	Duty Factor	PSD with Duty Factor (dBm/500kHz)	LIMIT (dBm/500kHz)	PASS /FAIL
155	5775	6.15	3.14	0.48	3.62	30	PASS



BUREAU VERITAS

Test Report No.: RF180523W002-3

For 5180~5240MHz

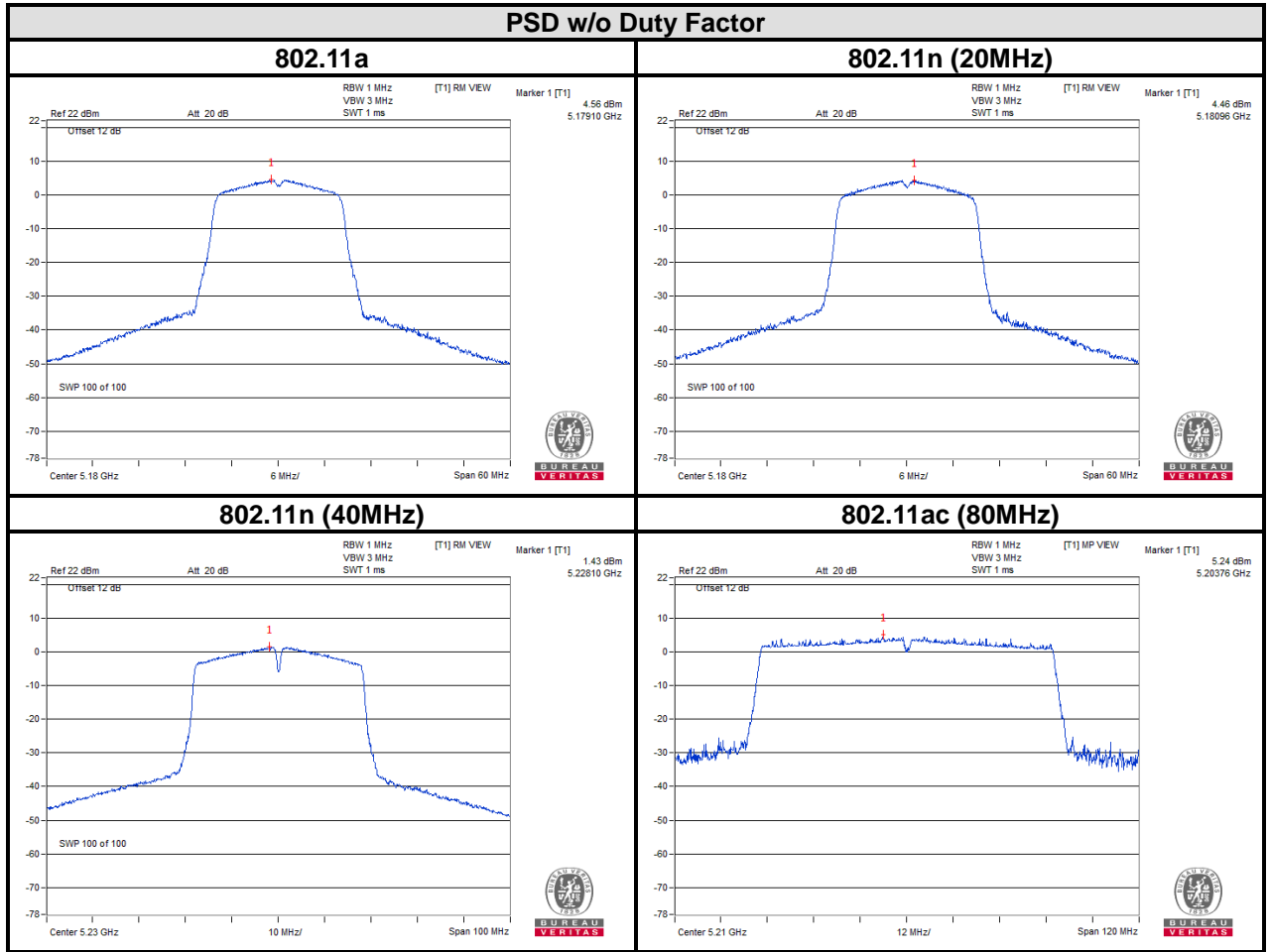



BUREAU VERITAS

Test Report No.: RF180523W002-3

For 5260~5320MHz

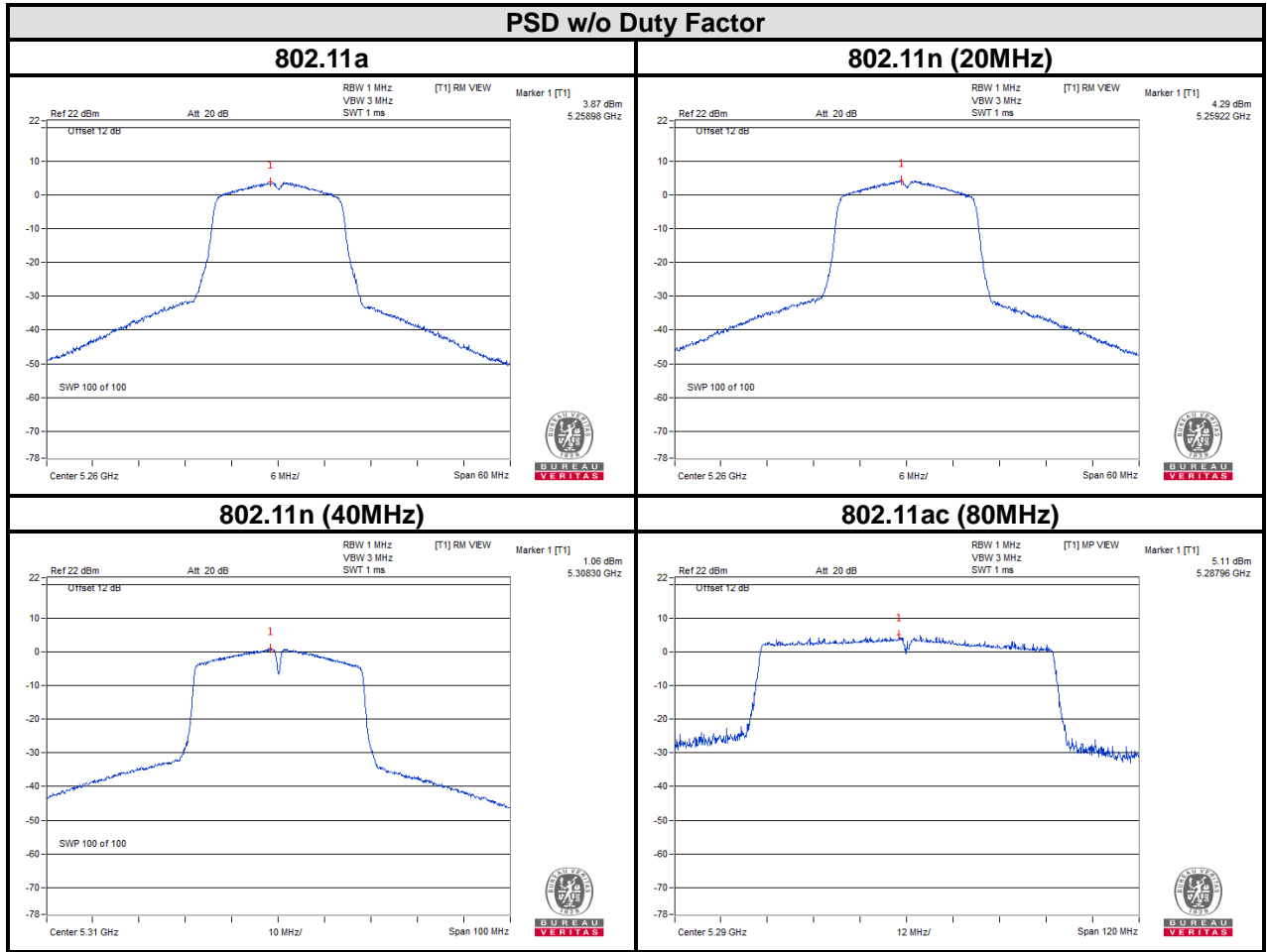



BUREAU VERITAS

Test Report No.: RF180523W002-3

For 5500~5700MHz

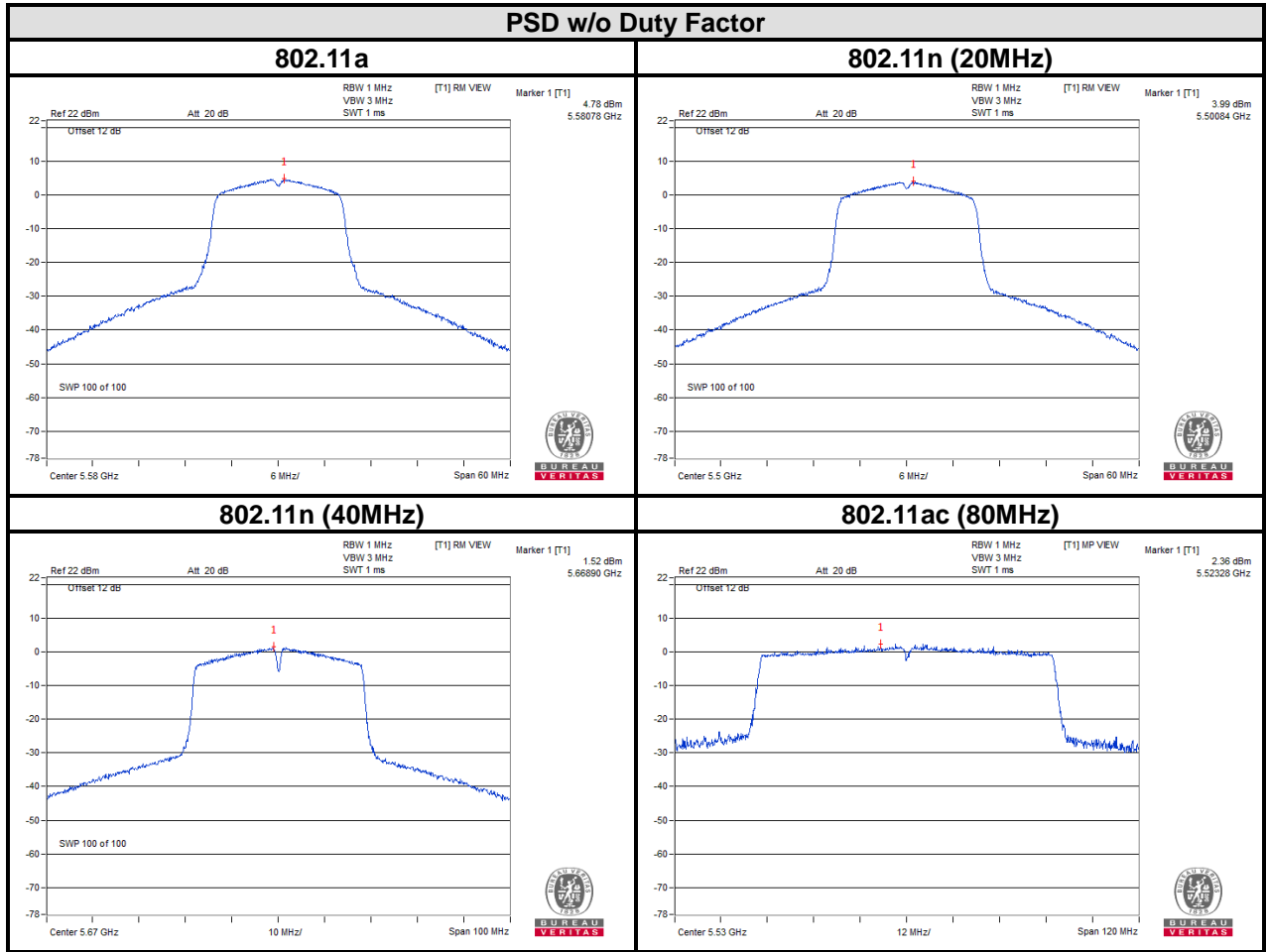



BUREAU
VERITAS

Test Report No.: RF180523W002-3

For 5745~5825MHz

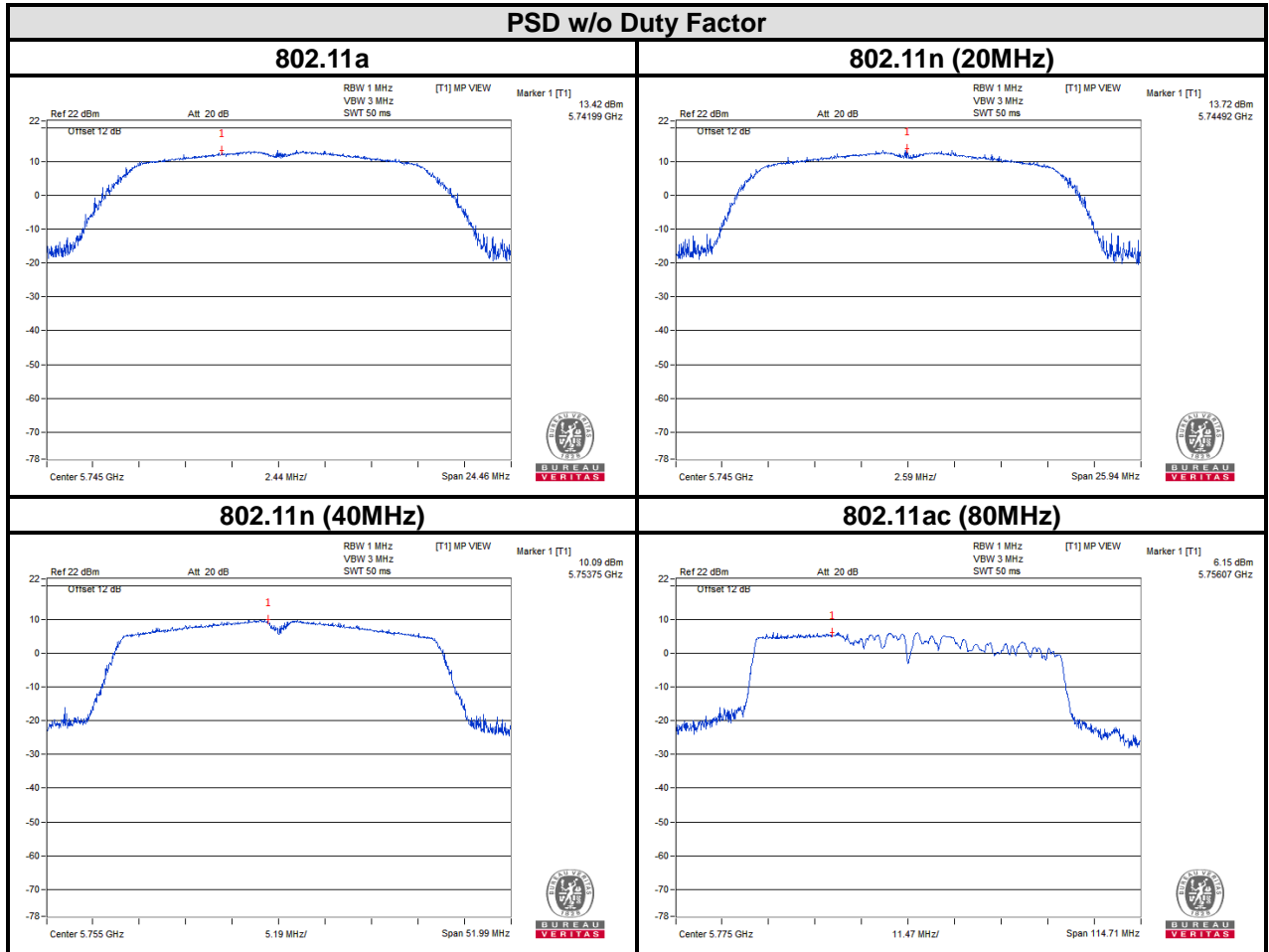



3.5 FREQUENCY STABILITY

3.5.1 LIMITS OF FREQUENCY STABILITY MEASUREMENT

The frequency of the carrier signal shall be maintained within band of operation

3.5.2 TEST SETUP

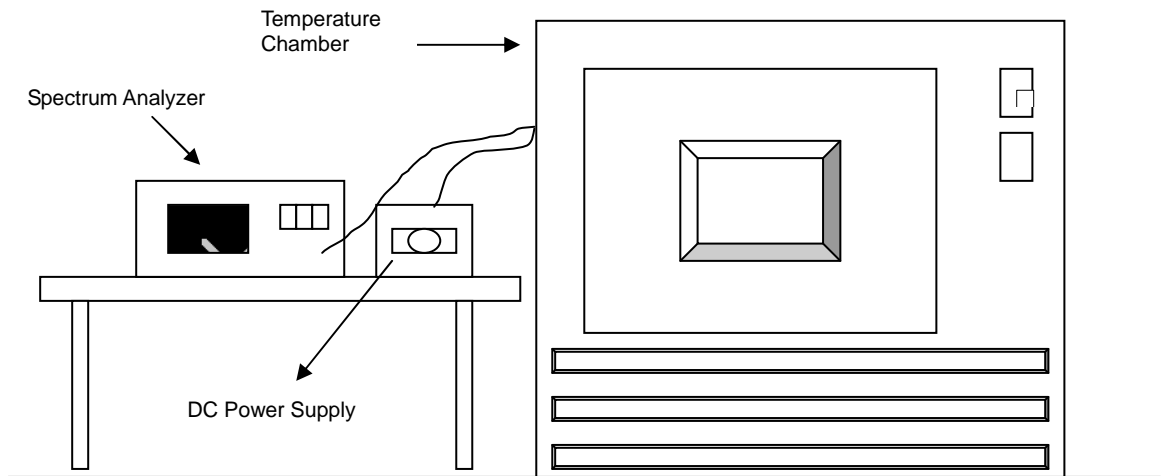

3.5.3 TEST INSTRUMENTS

Refer to section 3.3.3 to get information of above instrument.



3.5.4 TEST PROCEDURE

- a. The EUT was placed inside the environmental test chamber and powered by nominal DC voltage.
- b. Turn the EUT on and couple its output to a spectrum analyzer.
- c. Turn the EUT off and set the chamber to the highest temperature specified.
- d. Allow sufficient time (approximately 30 min) for the temperature of the chamber to stabilize, turn the EUT on and measure the operating frequency after 2, 5, and 10 minutes.
- e. Repeat step 2 and 3 with the temperature chamber set to the lowest temperature.
- f. The test chamber was allowed to stabilize at +20 degree C for a minimum of 30 minutes. The supply voltage was then adjusted on the EUT from 85% to 115% and the frequency record.

3.5.5 DEVIATION FROM TEST STANDARD

No deviation.

3.5.6 EUT OPERATING CONDITION

Set the EUT transmit at un-modulation mode to test frequency stability.



3.5.7 TEST RESULTS

FREQUENCY STABILITY VERSUS TEMP.										
OPERATING FREQUENCY: 5180MHz										
TEMP. (°C)	Power Supply (Vdc)	0 MINUTE		2 MINUTES		5 MINUTES		10 MINUTE		RESULT
		Measured Frequency (MHz)	Frequency Drift (ppm)	Measured Frequency (MHz)	Frequency Drift (ppm)	Measured Frequency (MHz)	Frequency Drift (ppm)	Measured Frequency (MHz)	Frequency Drift (ppm)	
50	120	5180.0031	0.598	5180.002	0.386	5180.0056	1.081	5180.0024	0.463	PASS
40	120	5179.9806	-3.745	5179.9821	-3.456	5179.9809	-3.687	5179.9797	-3.919	PASS
30	120	5179.9694	-5.907	5179.9797	-3.919	5179.9776	-4.324	5179.9731	-5.193	PASS
20	120	5179.9886	-2.201	5179.9871	-2.490	5179.9903	-1.873	5179.9903	-1.873	PASS
10	120	5179.9732	-5.174	5179.9723	-5.347	5179.9761	-4.614	5179.98	-3.861	PASS
0	120	5180.0054	1.042	5180.007	1.351	5180.0031	0.598	5180.0026	0.502	PASS
-10	120	5179.9856	-2.780	5179.9872	-2.471	5179.9772	-4.402	5179.9847	-2.954	PASS
-20	120	5180.0117	2.259	5180.011	2.124	5180.014	2.703	5180.0094	1.815	PASS
-30	120	5179.9897	-1.988	5179.9946	-1.042	5179.9901	-1.911	5179.9955	-0.869	PASS

FREQUENCY STABILITY VERSUS VOLTAGE										
OPERATING FREQUENCY: 5180MHz										
TEMP. (°C)	Power Supply (Vdc)	0 MINUTE		2 MINUTE		5 MINUTE		10 MINUTE		RESULT
		Measured Frequency (MHz)	Frequency Drift (ppm)	Measured Frequency (MHz)	Frequency Drift (ppm)	Measured Frequency (MHz)	Frequency Drift (ppm)	Measured Frequency (MHz)	Frequency Drift (ppm)	
20	138	5179.9878	-2.355	5179.9887	-2.181	5179.9916	-1.622	5179.991	-1.737	PASS
	120	5179.9886	-2.201	5179.9871	-2.490	5179.9903	-1.873	5179.9903	-1.873	PASS
	102	5179.988	-2.317	5179.9876	-2.394	5179.9899	-1.950	5179.9899	-1.950	PASS



FREQUENCY STABILITY VERSUS TEMP.										
OPERATING FREQUENCY: 5825MHz										
TEMP. (°C)	Power Supply (Vdc)	0 MINUTE		2 MINUTES		5 MINUTES		10 MINUTE		RESULT
		Measured Frequency (MHz)	Frequency Drift (ppm)	Measured Frequency (MHz)	Frequency Drift (ppm)	Measured Frequency (MHz)	Frequency Drift (ppm)	Measured Frequency (MHz)	Frequency Drift (ppm)	
50	120	5824.9874	-2.163	5824.9902	-1.682	5824.9897	-1.768	5824.9877	-2.112	PASS
40	120	5825.0054	0.927	5825.0117	2.009	5825.0044	0.755	5825.0101	1.734	PASS
30	120	5824.9985	-0.258	5825.005	0.858	5824.9972	-0.481	5824.9962	-0.652	PASS
20	120	5825.015	2.575	5825.0137	2.352	5825.0091	1.562	5825.0152	2.609	PASS
10	120	5824.9807	-3.313	5824.9819	-3.107	5824.9828	-2.953	5824.984	-2.747	PASS
0	120	5825.0034	0.584	5825.0027	0.464	5825.0108	1.854	5825.0002	0.034	PASS
-10	120	5824.9859	-2.421	5824.982	-3.090	5824.9884	-1.991	5824.9831	-2.901	PASS
-20	120	5824.9922	-1.339	5824.9935	-1.116	5824.9898	-1.751	5824.9939	-1.047	PASS
-30	120	5825.0189	3.245	5825.0185	3.176	5825.0169	2.901	5825.0205	3.519	PASS

FREQUENCY STABILITY VERSUS VOLTAGE										
OPERATING FREQUENCY: 5180MHz										
TEMP. (°C)	Power Supply (Vdc)	0 MINUTE		2 MINUTE		5 MINUTE		10 MINUTE		RESULT
		Measured Frequency (MHz)	Frequency Drift (ppm)	Measured Frequency (MHz)	Frequency Drift (ppm)	Measured Frequency (MHz)	Frequency Drift (ppm)	Measured Frequency (MHz)	Frequency Drift (ppm)	
20	138	5825.0142	2.438	5825.0131	2.249	5825.0096	1.648	5825.0166	2.850	PASS
	120	5825.015	2.575	5825.0137	2.352	5825.0091	1.562	5825.0152	2.609	PASS
	102	5825.0137	2.352	5825.0126	2.163	5825.0092	1.579	5825.0153	2.627	PASS



Test Report No.: RF180523W002-3

4 PHOTOGRAPHS OF THE TEST CONFIGURATION

Please refer to the attached file (Test Setup Photo).



Test Report No.: RF180523W002-3

5 APPENDIX A – MODIFICATIONS RECORDERS FOR ENGINEERING CHANGES TO THE EUT BY THE LAB

No modifications were made to the EUT by the lab during the test.

---END---