



Shenzhen CTL Electromagnetic Technology Co., Ltd.
Tel: +86-755-89486194 Fax: +86-755-89486187

FCC PART 15 SUBPART C TEST REPORT

FCC Part 15.247

Report Reference No.....: CTL11048239-S-WF

Compiled by

(position+printed name+signature) .: File administrators Andy Zhang

Name of the organization performing the tests

Test Engineer Kendy Wang

(position+printed name+signature) .:

Approved by

(position+printed name+signature) .: Manager Tracy Qi

Date of issue.....: May 05, 2011

Representative Laboratory Name .: Shenzhen CTL Electromagnetic Technology Co., Ltd.

Address: Zone B, 4/F, Block 20, Guangqian Industrial Park, Longzhu Road,Nanshan,Shenzhen 518055 China.

Test Firm: Bontek Compliance Testing Laboratory Ltd

Address: 1/F, Block East H-3, OCT Eastern Ind. Zone, Qiaocheng East Road, Nanshan, Shenzhen, China

Applicant's name.....: SHENZHEN MTN ELECTRONICS CO.,LTD.

Address: MTN Industrial Park, No. 3 Fuhua Road, Pingxi Neighborhood, Pingdi Town , Longgang District, Shenzhen

Test specification:

Standard: FCC Part 15.247: Operation within the bands 902–928 MHz, 2400–2483.5 MHz, and 5725–5850 MHz.

TRF Originator.....: Shenzhen CTL Electromagnetic Technology Co., Ltd.

Master TRF.....: Dated 2011-01

Shenzhen CTL Electromagnetic Technology Co., Ltd. All rights reserved.

This publication may be reproduced in whole or in part for non-commercial purposes as long as the Shenzhen CTL Electromagnetic Technology Co., Ltd. is acknowledged as copyright owner and source of the material. Shenzhen CTL Electromagnetic Technology Co., Ltd. takes no responsibility for and will not assume liability for damages resulting from the reader's interpretation of the reproduced material due to its placement and context.

Test item description: USB Wireless Adapter

FCC ID.....: ZBXWU-150R3

Trade Mark: /

Model/Type reference: WU-150R3

Listed Models: /

Modulation: DSSS, OFDM

Work Frequency Range.....: 2412~2462MHz

Antenna Type.....: N-SMA connector

Result: **Positive**

TEST REPORT

Test Report No. : CTL11048239-S-WF	May 05, 2011
	Date of issue

Equipment under Test : USB Wireless Adapter

Model /Type : WU-150R3

Listed Models : /

Applicant : SHENZHEN MTN ELECTRONICS CO.,LTD.

Address : MTN Industrial Park, No. 3 Fuhua Road, Pingxi Neighborhood, Pingdi Town , Longgang District, Shenzhen

Manufacturer SHENZHEN MTN ELECTRONICS CO.,LTD.

Address MTN Industrial Park, No. 3 Fuhua Road, Pingxi Neighborhood, Pingdi Town , Longgang District, Shenzhen

Test Result according to the standards on page 4:	Positive
--	-----------------

The test report merely corresponds to the test sample.
It is not permitted to copy extracts of these test result without the written permission of the test laboratory.

Contents

1.	<u>TEST STANDARDS</u>	4
2.	<u>SUMMARY</u>	5
2.1.	General Remarks	5
2.2.	Equipment Under Test	5
2.3.	Short description of the Equipment under Test (EUT)	5
2.4.	EUT operation mode	5
2.5.	EUT configuration	6
2.6.	NOTE	6
2.7.	Related Submittal(s) / Grant (s)	6
2.8.	Modifications	6
3.	<u>TEST ENVIRONMENT</u>	7
3.1.	Address of the test laboratory	7
3.2.	Test Facility	7
3.3.	Environmental conditions	7
3.4.	Configuration of Tested System	7
3.5.	Statement of the measurement uncertainty	8
3.6.	Equipments Used during the Test	8
3.7.	Summary of Test Result	9
4.	<u>TEST CONDITIONS AND RESULTS</u>	10
4.1.	Conducted Emissions Test	10
4.2.	Radiated Emission Test	13
4.3.	6dB Bandwidth Measurement	30
4.4.	Maximum Peak Output Power	33
4.5.	Band Edge Measurement	36
4.6.	Power Spectral Density Measurement	53
4.7.	Spurious RF Conducted Emission	56
4.8.	Antenna Requirement	73
5.	<u>TEST SETUP PHOTOS OF THE EUT</u>	74
6.	<u>EXTERNAL AND INTERNAL PHOTOS OF THE EUT</u>	75

1. TEST STANDARDS

The tests were performed according to following standards:

[FCC Part 15.247](#): Frequency Hopping, Direct Spread Spectrum and Hybrid Systems that are in operation within the bands of 902-928 MHz, 2400-2483.5 MHz, and 5725-5850 MHz.

[ANSI C63.4-2003](#)

[KDB Publication No. 558074 Guidance on Measurements for Digital Transmission Systems](#)

[ANSI C63.10-2009](#): American National Standard for Testing Unlicensed Wireless Devices.



2. SUMMARY

2.1. General Remarks

Date of receipt of test sample : April 28, 2011

Testing commenced on : April 29, 2011

Testing concluded on : April 30, 2011

2.2. Equipment Under Test

Power supply system utilised

Power supply voltage : 120V / 60 Hz 115V / 60Hz
 12 V DC 24 V DC
 Other (specified in blank below)

DC 5V from USB

Description of the test mode

IEEE 802.11b/g/n: Thirteen channels are provided to the EUT, but only eleventh channels used for USA.

Channel	Frequency(MHz)	Channel	Frequency(MHz)
1	2412	8	2447
2	2417	9	2452
3	2422	10	2457
4	2427	11	2462
5	2432		
6	2437		
7	2442		

2.3. Short description of the Equipment under Test (EUT)

2.4GHz (Wireless Router N with USB)

For more details, refer to the user's manual of the EUT.

Serial number: Prototype

2.4. EUT operation mode

Test Mode:

1. The EUT has been tested under normal operating condition.
2. Test program used to control the EUT for staying in continuous transmitting and receiving mode is programmed. Channel low (2412MHz), mid (2442MHz) and high (2462MHz) with highest data rate are chosen for full testing.

2.5. EUT configuration

The following peripheral devices and interface cables were connected during the measurement:

- - supplied by the manufacturer

- Mouse

Manufacturer : DELL

Model No. : MOC5UO

- Keyboard

Manufacturer : DELL

Model No. : L100

2.6. NOTE

1. The EUT is an 802.11b/g/n MID, The functions of the EUT listed as below:

	Test Standards	Reference Report
WLAN 802.11b/g, 802.11n	FCC Part 15 Subpart C (Section15.247)	CTL11048239-S-WF

2. The frequency bands used in this EUT are listed as follows:

Frequency Band(MHz)	2400-2483.5	5150-5350	5470-5725	5725-5850
802.11b	√	—	—	—
802.11g	√	—	—	—
802.11n(20MHz)	√	—	—	—
802.11n(40MHz)	√	—	—	—

3. The EUT incorporates a SISO function, Physically, the EUT provides one completed transmitter and one completed receiver.

Modulation Mode	TX Function
802.11b	1TX
802.11g	1TX
802.11n (20MHz)	1TX
802.11n (40MHz)	1TX

2.7. Related Submittal(s) / Grant (s)

This submittal(s) (test report) is intended for FCC ID: **ZBXWU-150R3** filing to comply with of the FCC Part 15.247 Rules.

2.8. Modifications

No modifications were implemented to meet testing criteria.

3. TEST ENVIRONMENT

3.1. Address of the test laboratory

Bontek Compliance Testing Laboratory Ltd
 1/F, Block East H-3, OCT Eastern Ind. Zone, Qiaocheng East Road, Nanshan, Shenzhen, China

The sites are constructed in conformance with the requirements of ANSI C63.7, ANSI C63.4 (2003) and CISPR Publication 22.

3.2. Test Facility

The test facility is recognized, certified, or accredited by the following organizations:

IC Registration No.: 7631A

The 3m alternate test site of Bontek Compliance Testing Laboratory Ltd EMC Laboratory has been registered by Certification and Engineer Bureau of Industry Canada for the performance of with Registration NO.: 7631A on March, 2008.

FCC-Registration No.: 338263

Bontek Compliance Testing Laboratory Ltd EMC Laboratory has been registered and fully described in a report filed with the (FCC) Federal Communications Commission. The acceptance letter from the FCC is maintained in our files. Registration 338263, March 24, 2008.

3.3. Environmental conditions

During the measurement the environmental conditions were within the listed ranges:

Temperature:	<u>15-35 ° C</u>
Humidity:	<u>30-60 %</u>
Atmospheric pressure:	<u>950-1050mbar</u>

3.4. Configuration of Tested System

Fig. 2-1 Configuration of Tested System

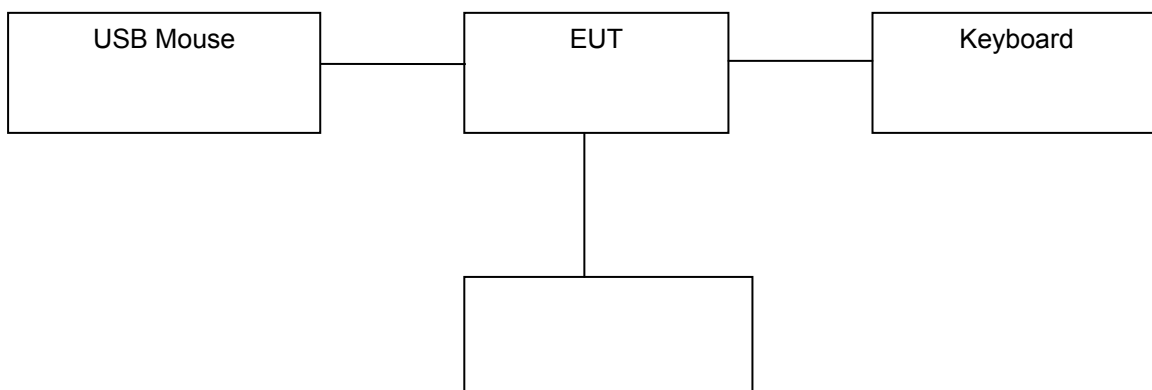

3.5. Statement of the measurement uncertainty

The data and results referenced in this document are true and accurate. The reader is cautioned that there may be errors within the calibration limits of the equipment and facilities. The measurement uncertainty was calculated for all measurements listed in this test report acc. to CISPR 16 - 4 „Specification for radio disturbance and immunity measuring apparatus and methods – Part 4: Uncertainty in EMC Measurements“ and is documented in the Bontek Compliance Testing Laboratory Ltd quality system acc. to DIN EN ISO/IEC 17025. Furthermore, component and process variability of devices similar to that tested may result in additional deviation. The manufacturer has the sole responsibility of continued compliance of the device.

Hereafter the best measurement capability for Bontek laboratory is reported:

Test	Range	Measurement Uncertainty	Notes
Radiated Emission	30~1000MHz	4.10dB	(1)
Radiated Emission	1~12.75GHz	4.32dB	(1)
Conducted Disturbance	0.15~30MHz	3.20dB	(1)

- (1) This uncertainty represents an expanded uncertainty expressed at approximately the 95% confidence level using a coverage factor of k=2.

3.6. Equipments Used during the Test

Item	Test Equipment	Manufacturer	Model No.	Last Cal.	Due. Date
1	EMI Test Receiver	ROHDE & SCHWARZ	ESCI	2011/04/14	2012/04/13
2	Spectrum Analyzer	Agilent	E4402B	2011/04/14	2012/04/13
3	Dual Directional Coupler	Agilent	778D	2011/04/14	2012/04/13
4	10dB attenuator	SCHWARZBECK	MTAIMP-136	2011/04/14	2012/04/13
5	Tunable Bandreject filter	K&L	3TNF-800	2011/04/14	2012/04/13
6	Tunable Bandreject filter	K&L	5TNF-1700	2011/04/14	2012/04/13
7	High-Pass Filter	K&L	9SH10-2700/X12750-O/O	2011/04/14	2012/04/13
8	High-Pass Filter	K&L	41H10-1375/U12750-O/O	2011/04/14	2012/04/13
9	Coaxial Cable	Huber+Suhner	AC4-RF-H	2011/04/14	2012/04/13
10	AC Power Supply	IDRC	CF-500TP	2011/04/14	2012/04/13
11	DC Power Supply	IDRC	CD-035-020PR	2011/04/14	2012/04/13
12	RF Current Probe	FCC	F-33-4	2011/04/14	2012/04/13
13	Temperature /Humidity Meter	zhicheng	ZC1-2	2011/04/14	2012/04/13
14	MICROWAVE AMPLIFIER	HP	8349B	2011/04/14	2012/04/13
15	Amplifier	HP	8447D	2011/04/14	2012/04/13
16	SIGNAL GENERATOR	HP	8647A	2011/04/14	2012/04/13
17	Log Periodic Antenna	ELECTRO-METRICS	EM-6950	2011/04/14	2012/04/13
18	Horn Antenna	Schwarzbeck	BBHA9120A	2011/04/14	2012/04/13
19	EMI Test Receiver	R&S	ESPI	2011/04/14	2012/04/13
20	Spectrum Analyzer	Agilent	E7405A	2011/04/14	2012/04/13
21	Spectrum Analyzer	HP	8593E	2011/04/14	2012/04/13

3.7. Summary of Test Result

FCC PART 15		
FCC Part 15.207	AC Power Conducted Emission	PASS
FCC Part 15.247(a)(2)	6dB Bandwidth	PASS
FCC Part 15.247(d)	Spurious RF Conducted Emission	PASS
FCC Part 15.247(b)	Maximum Peak Output Power	PASS
FCC Part 15.247(e)	Power Spectral Density	PASS
FCC Part 15.109/ 15.205/ 15.209	Radiated Emissions	PASS
FCC Part 15.247(d)	Band Edge Compliance of RF Emission	PASS
FCC Part 15.203/15.247 (b)	Antenna Requirement	PASS
FCC Per 47 CFR 2.1091(b)	MPE Evaluation	PASS

Remark: The measurement uncertainty is not included in the test result.

Preliminary tests were performed in different data rate to find the worst radiated emission. The data rate shown in the table below is the worst-case rate with respect to the specific test item. Investigation has been done on all the possible configurations for searching the worst cases. The following table is a list of the test modes shown in this test report.

Test Items	Mode	Data Rate	Channel
AC Power Conducted Emission	Normal Link	11 Mbps	1
Maximum Peak Conducted Output Power Power Spectral Density 6dB Bandwidth Spurious RF conducted emission	11b/DSSS	11 Mbps	1/6/11
	11g/OFDM	54 Mbps	1/6/11
	11n(20MHz)/OFDM	65Mbps	1/6/11
	11n(40MHz)/OFDM	135Mbps	3/6/9
Radiated Emission 30MHz~1GHz	11b/DSSS	11 Mbps	1/6/11
	11g/OFDM	54 Mbps	1/6/11
	11n(20MHz)/OFDM	65Mbps	1/6/11
	11n(40MHz)/OFDM	135Mbps	3/6/9
Radiated Emission 1GHz~10th Harmonic	11b/DSSS	11 Mbps	1/6/11
	11g/OFDM	54 Mbps	1/6/11
	11n(20MHz)/OFDM	65Mbps	1/6/11
	11n(40MHz)/OFDM	135Mbps	3/6/9
Band Edge Compliance of RF Emission	11b/DSSS	11 Mbps	1/11
	11g/OFDM	54 Mbps	1/11
	11n(20MHz)/OFDM	65Mbps	1/11
	11n(40MHz)/OFDM	135Mbps	3/9

Note1: According exploratory test, EUT will have maximum output power in those data rate, so those data rate were used for all test.

4. TEST CONDITIONS AND RESULTS

4.1. Conducted Emissions Test

TEST CONFIGURATION

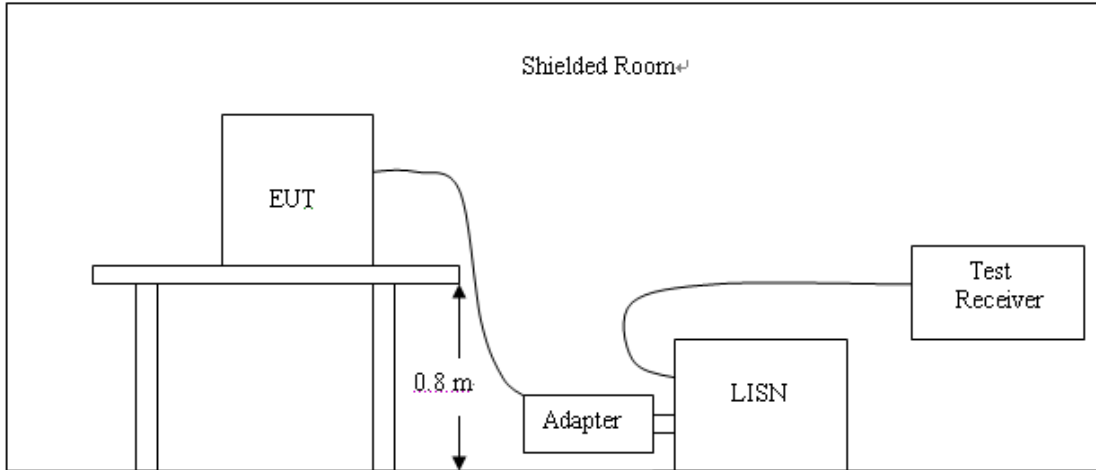

TEST PROCEDURE

For unintentional device, according to § 15.107(a) Line Conducted Emission Limits is as following:

Frequency (MHz)	Maximum RF Line Voltage (dB μ v)			
	CLASS A		CLASS B	
	Q.P.	Ave.	Q.P.	Ave.
0.15 - 0.50	79	66	66-56*	56-46*
0.50 - 5.00	73	60	56	46
5.00 - 30.0	73	60	60	50

* Decreasing linearly with the logarithm of the frequency

For intentional device, according to §15.207(a) Line Conducted Emission Limit is same as above table.

1. Please follow the guidelines in ANSI C63.4-2003.
2. The EUT was placed 0.4 meter from the conducting wall of the shielding room was kept at least 80 centimeters from any other grounded conducting surface.
3. Connect EUT to the power mains through a line impedance stabilization network (LISN).
4. All the support units are connecting to the other LISN.
5. The LISN provides 50 ohm coupling impedance for the measuring instrument.
6. The FCC states that a 50 ohm, 50 microhenry LISN should be used.
7. Both sides of AC line were checked for maximum conducted interference.
8. The frequency range from 150 kHz to 30 MHz was searched.
9. Set the test-receiver system to Peak Detect Function and specified bandwidth with Maximum Hold Mode.

The RBW/VBW for 150KHz to 30MHz: 9KHz

TEST RESULTS

Line 1:

SCAN TABLE: "Voltage (9K-30M) FIN"

Short Description: 150K-30M Voltage

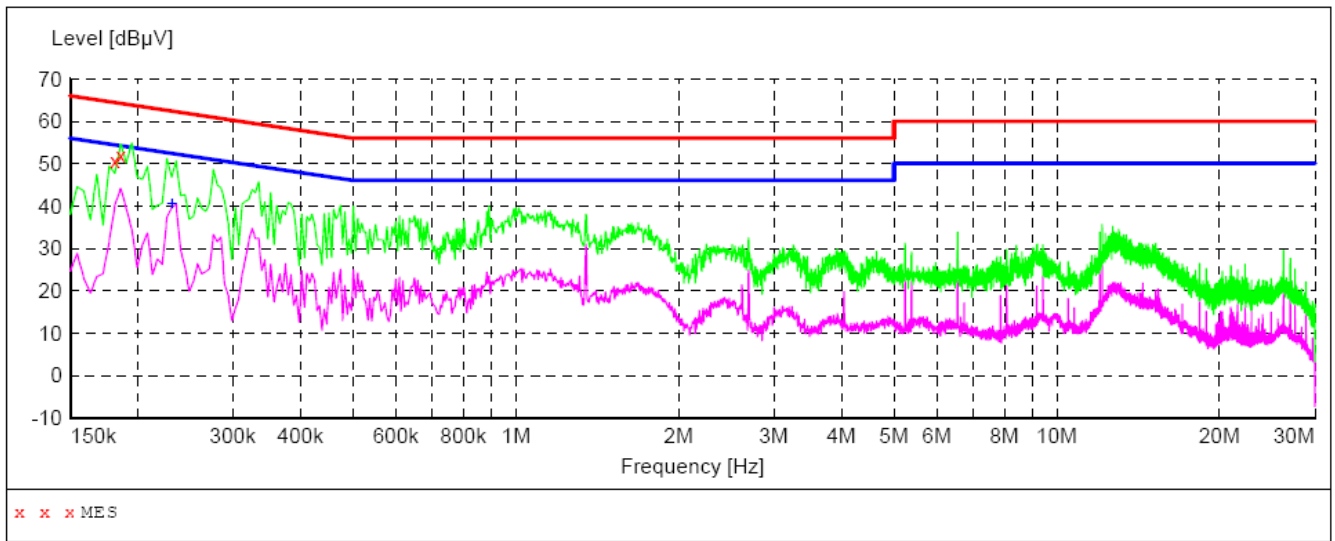

MEASUREMENT RESULT:

Frequency MHz	Level dBµV	Transd dB	Limit dBµV	Margin dB	Detector	Line	PE
0.181500	50.80	11.0	64	13.6	QP	L1	GND
0.186000	51.90	11.0	64	12.3	QP	L1	GND

MEASUREMENT RESULT:

Frequency MHz	Level dBµV	Transd dB	Limit dBµV	Margin dB	Detector	Line	PE
0.231000	40.70	10.7	52	11.7	AV	L1	GND

Line 2:

SCAN TABLE: "Voltage (9K-30M)FIN"
 Short Description: 150K-30M Voltage

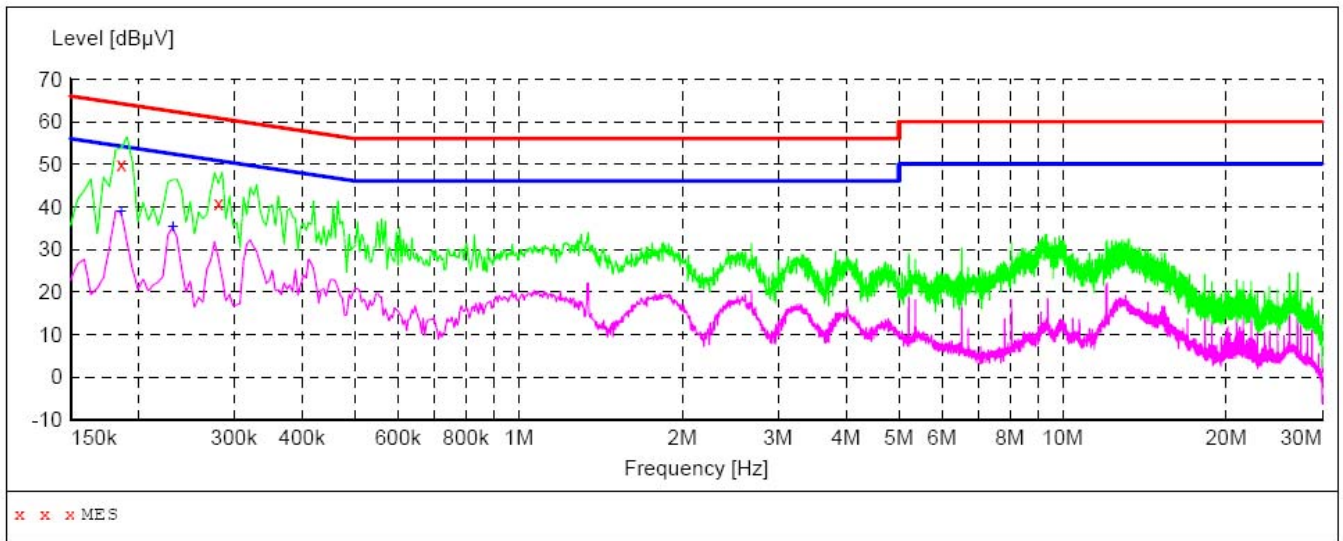

MEASUREMENT RESULT:

Frequency MHz	Level dBµV	Transd dB	Limit dBµV	Margin dB	Detector	Line	PE
0.186000	49.90	11.0	64	14.3	QP	N	GND
0.280500	40.90	10.6	61	19.9	QP	N	GND

MEASUREMENT RESULT:

Frequency MHz	Level dBµV	Transd dB	Limit dBµV	Margin dB	Detector	Line	PE
0.186000	38.90	11.0	54	15.3	AV	N	GND
0.231000	35.40	10.7	52	17.0	AV	N	GND

4.2. Radiated Emission Test

TEST CONFIGURATION

(A) Radiated Emission Test Set-Up, Frequency Below 30MHz

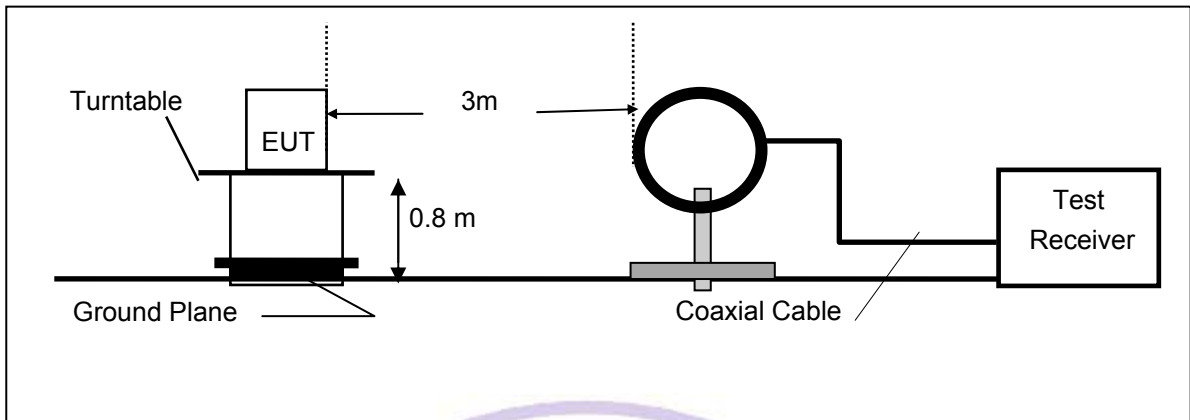

(B) Radiated Emission Test Set-Up, Frequency Below 1000MHz

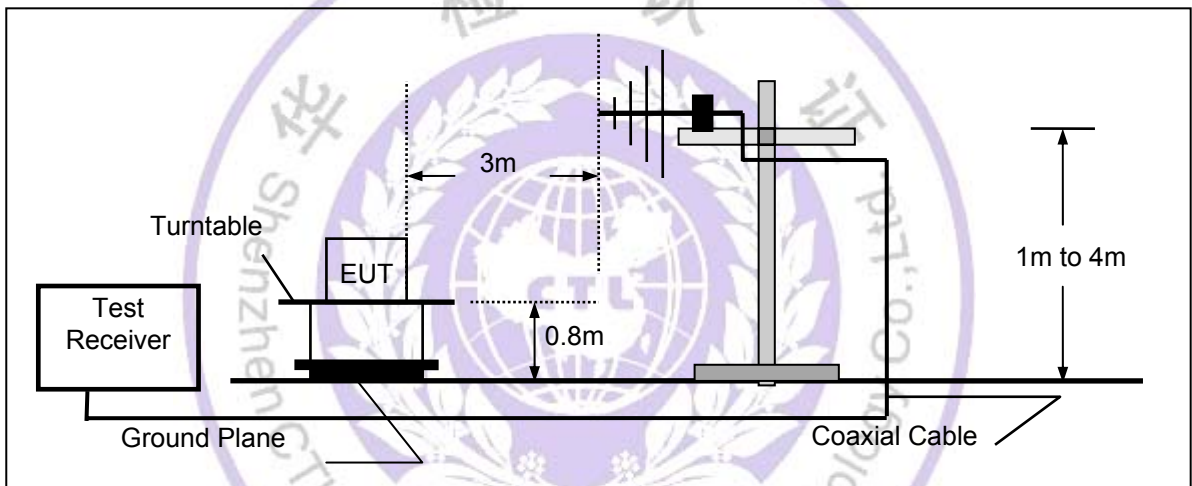

(C) Radiated Emission Test Set-Up, Frequency above 1000MHz

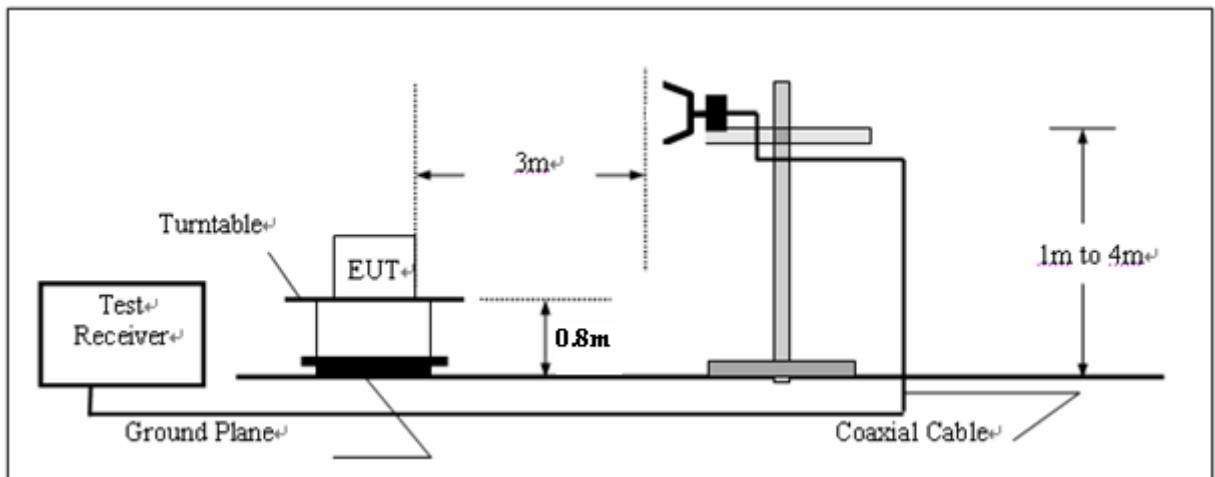

FIELD STRENGTH CALCULATION

The field strength is calculated by adding the Antenna Factor and Cable Factor and subtracting the Amplifier Gain and Duty Cycle Correction Factor(if any) from the measured reading. The basic equation with a sample calculation is as follows:

$$FS = RA + AF + CL - AG$$

Where FS = Field Strength	CL = Cable Attenuation Factor (Cable Loss)
RA = Reading Amplitude	AG = Amplifier Gain
AF = Antenna Factor	

TEST PROCEDURE

1. The testing follows FCC KDB Publication No. 558074 (Measurement Guidelines of DTS).
2. The EUT was placed on a turn table which is 0.8m above ground plane.
3. Maximum procedure was performed by raising the receiving antenna from 1m to 4m and rotating the turn table from 0° to 360° to acquire the highest emissions from EUT
4. And also, each emission was to be maximized by changing the polarization of receiving antenna both horizontal and vertical.
5. Span = wide enough to fully capture the emission being measured; RBW = 1 MHz for $f > 1$ GHz, 100 kHz for $f < 1$ GHz; VBW=RBW; Sweep = auto; Detector function = peak; Trace = max hold.
6. Repeat above procedures until all frequency measurements have been completed.

LIMIT

For unintentional device, according to § 15.109(a), except for Class A digital devices, the field strength of radiated emissions from unintentional radiators at a distance of 3 meters shall not exceed the following values:

Frequency (MHz)	Distance (Meters)	Radiated (dB μ V/m)	Radiated (μ V/m)
30-88	3	40.0	100
88-216	3	43.5	150
216-960	3	46.0	200
Above 960	3	54.0	500

For intentional device, according to § 15.209(a), the general requirement of field strength of radiated emissions from intentional radiators at a distance of 3 meters shall not exceed the above table. According to § 15.247(d), in any 100kHz bandwidth outside the frequency band in which the EUT is operating, the radio frequency power that is produced by the intentional radiator shall be at least 20dB below that in the 100kHz bandwidth within the band that contains the highest level of desired power.

TEST RESULTS

Below 1GHz:

The radiated measurement are performed the each test mode (b/g/n) and channel (low/mid/high), the datum recorded below (802.11b mode, the middle channel) is the worst case for all the test mode and channel.

SWEEP TABLE: "test (30M-1G)"

Short Description:		Field Strength				Transducer
Start	Stop	Detector	Meas.	IF		
Frequency	Frequency		Time	Bandw.		
30.0 MHz	1.0 GHz	MaxPeak	Coupled	100 kHz	VULB9163 NEW	

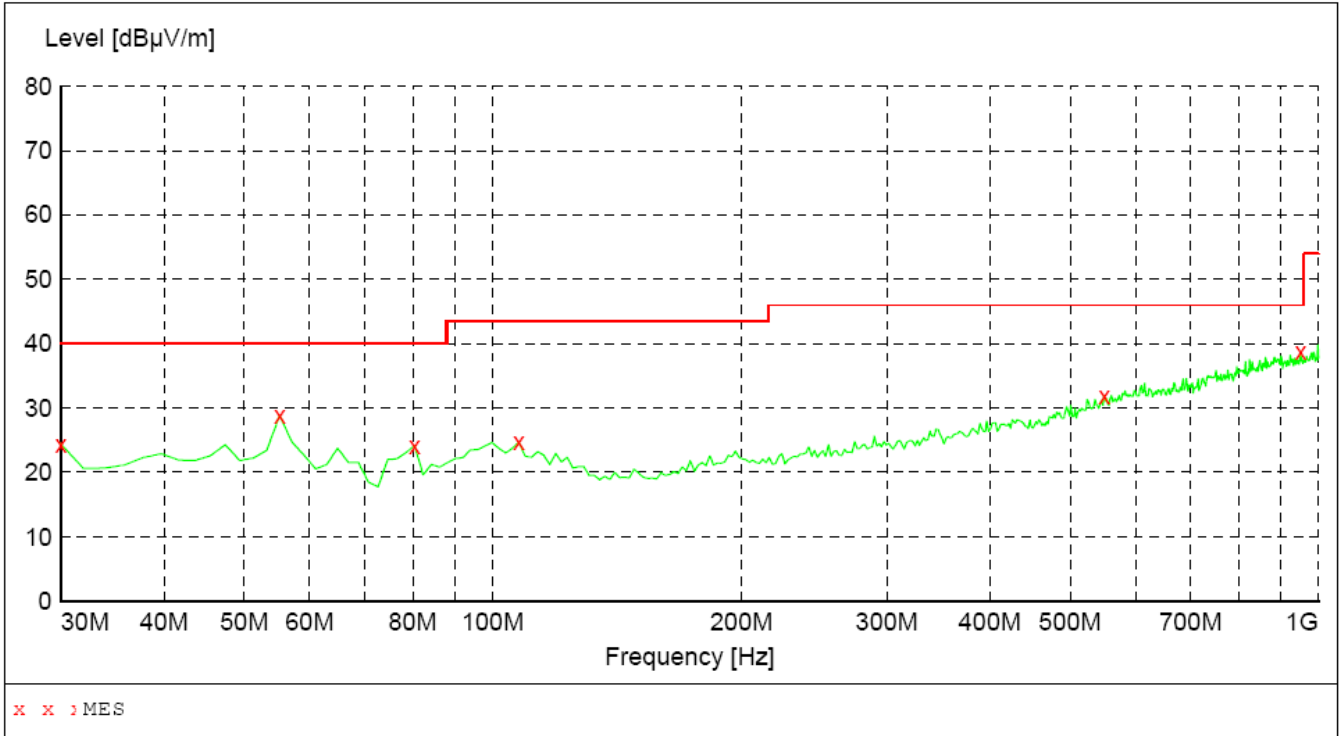

MEASUREMENT RESULT:

Frequency MHz	Level dBµV/m	Transd dB	Limit dBµV/m	Margin dB	Det.	Height cm	Azimuth deg	Polarization
30.000000	24.40	14.3	40.0	15.6	---	100.0	0.00	HORIZONTAL
55.220000	28.90	15.6	40.0	11.1	---	300.0	0.00	HORIZONTAL
80.440000	24.20	12.7	40.0	15.8	---	300.0	0.00	HORIZONTAL
107.600000	24.70	16.9	43.5	18.8	---	100.0	0.00	HORIZONTAL
549.920000	31.90	25.2	46.0	14.1	---	100.0	0.00	HORIZONTAL
951.500000	38.80	31.8	46.0	7.2	---	300.0	0.00	HORIZONTAL

SWEEP TABLE: "test (30M-1G)"

Short Description:		Field Strength			
Start	Stop	Detector	Meas. Time	IF Bandw.	Transducer
Frequency 30.0 MHz	Frequency 1.0 GHz	MaxPeak	Coupled	100 kHz	VULB9163 NEW

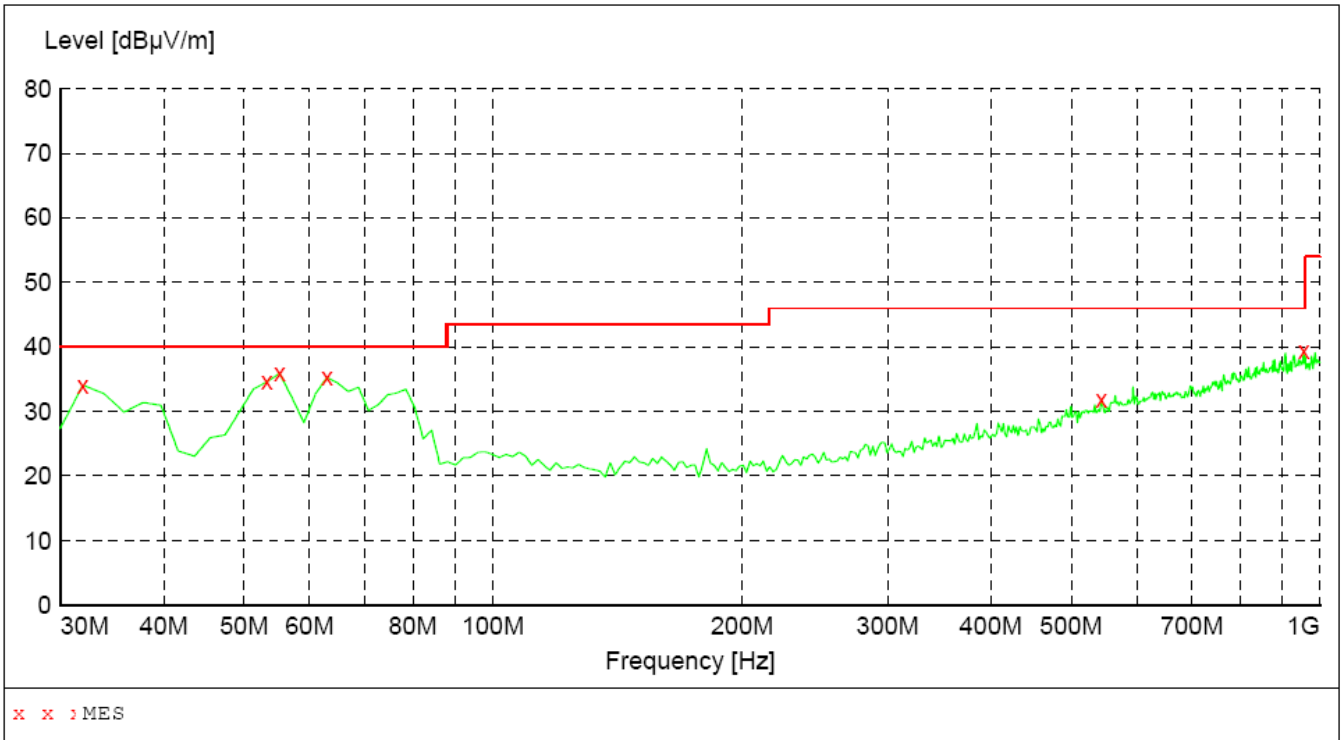

MEASUREMENT RESULT:

Frequency MHz	Level dBµV/m	Transd dB	Limit dBµV/m	Margin dB	Det.	Height cm	Azimuth deg	Polarization
31.940000	34.10	14.4	40.0	5.9	---	100.0	0.00	VERTICAL
53.280000	34.60	15.7	40.0	5.4	---	100.0	0.00	VERTICAL
55.220000	35.90	15.6	40.0	4.1	---	100.0	0.00	VERTICAL
62.980000	35.30	13.9	40.0	4.7	---	100.0	0.00	VERTICAL
544.100000	31.90	25.0	46.0	14.1	---	100.0	0.00	VERTICAL
955.380000	39.40	31.8	46.0	6.6	---	100.0	0.00	VERTICAL

Above 1GHz:
802.11b CH1

ANTENNA POLARITY & TEST DISTANCE: HORIZONTAL AT 3 M

No.	Frequency (MHz)	Emission Level (dBuV/m)		Limit (dBuV/m)	Margin (dB)	Antenna Height (m)	Table Angle (Degree)	Raw Value (dBuV)	Antenna Factor (dB/m)	Cable Factor (dB)	Pre-amplifier (dB)	Correction Factor (dB/m)
1	2390.00	51.83	PK	74.00	22.17	1.00 H	200	55.23	28.3	4.90	36.6	-3.40
1	2390.00	44.11	AV	54.00	9.89	1.00 H	200	47.41	28.3	4.90	36.6	-3.40
2	*2412.00	107.46	PK			1.00 H	333	110.86	28.3	4.90	36.6	-3.40
2	*2412.00	92.10	AV			1.00 H	333	95.50	28.3	4.90	36.6	-3.40
3	4824.00	48.23	PK	74.00	25.77	1.00 H	125	45.03	32.7	7.00	36.5	3.20
3	4824.00	41.00	AV	54.00	13.00	1.00 H	125	37.80	32.7	7.00	36.5	3.20
4	7236.00	57.21	PK	74.00	16.79	1.00 H	66	47.81	35.8	8.90	35.3	9.40
4	7236.00	44.35	AV	54.00	9.65	1.00 H	66	34.95	35.8	8.90	35.3	9.40
5	9648.00	54.23	PK	74.00	19.77	1.00 H	264	41.63	37.2	10.20	34.8	12.60
5	9648.00	45.00	AV	54.00	9.00	1.00 H	264	32.40	037.2	10.20	34.8	12.60

ANTENNA POLARITY & TEST DISTANCE: VERTICAL AT 3 M

No.	Frequency (MHz)	Emission Level (dBuV/m)		Limit (dBuV/m)	Margin (dB)	Antenna Height (m)	Table Angle (Degree)	Raw Value (dBuV)	Antenna Factor (dB/m)	Cable Factor (dB)	Pre-amplifier (dB)	Correction Factor (dB/m)
1	2390.00	51.89	PK	74.00	22.11	1.0	236	55.29	28.3	4.90	36.6	-3.40
1	2390.00	45.49	AV	54.00	8.51	1.0	236	48.89	28.3	4.90	36.6	-3.40
2	*2412.00	108.96	PK			1.0	100	112.36	28.3	4.90	36.6	-3.40
2	*2412.00	92.21	AV			1.0	100	95.55	28.3	4.90	36.6	-3.40
3	4824.00	58.23	PK	74.00	15.77	1.0	312	55.03	32.7	7.00	36.5	3.20
3	4824.00	43.00	AV	54.00	11.00	1.0	312	39.80	32.7	7.00	36.5	3.20
4	7236.00	61.12	PK	74.00	12.88	1.0	46	51.72	35.8	8.90	35.3	9.40
4	7236.00	44.17	AV	54.00	9.83	1.0	46	34.77	35.8	8.90	35.3	9.40
5	9648.00	55.64	PK	74.00	18.36	1.0	108	43.04	37.2	10.20	34.8	12.60
5	9648.00	45.57	AV	54.00	8.43	1.0	108	32.97	37.2	10.20	34.8	12.60

REMARKS:

1. Emission level (dBuV/m) = Raw Value (dBuV) + Correction Factor (dB/m)
2. Correction Factor (dB/m) = Antenna Factor (dB/m) + Cable Factor (dB) - Pre-amplifier Factor
3. The other emission levels were very low against the limit.
4. Margin value = Limit value - Emission level.
5. The limit value is defined as per 15.247
6. "*" : Fundamental frequency
7. For Wireless 802.11b mode at 11Mbps.

802.11b CH6

ANTENNA POLARITY & TEST DISTANCE: HORIZONTAL AT 3 M

No.	Frequency (MHz)	Emission Level (dBuV/m)	Limit (dBuV/m)	Margin (dB)	Antenna Height (m)	Table Angle (Degree)	Raw Value (dBuV)	Antenna Factor (dB/m)	Cable Factor (dB)	Pre-amplifier (dB)	Correction Factor (dB/m)
1	*2437.00	104.30 PK			1.00 H	153	107.50	28.3	5.10	-36.6	-3.20
1	*2437.00	94.30 AV			1.00 H	153	97.50	28.3	5.10	-36.6	-3.20
2	4874.00	45.40 PK	74.00	28.60	1.00 H	202	42.20	32.3	7.60	-36.5	3.40
2	4874.00	36.00 AV	54.00	18.00	1.00 H	202	32.60	32.3	7.60	-36.5	3.40
3	7311.00	53.10 PK	74.00	20.90	1.00 H	355	43.70	36.1	8.60	-35.3	9.40
3	7311.00	42.00 AV	54.00	12.00	1.00 H	355	32.60	36.1	8.60	-35.3	9.40
4	9748.00	56.20 PK	74.00	17.80	1.00 H	28	43.60	37.2	10.20	-34.8	12.60
4	9748.00	46.20 AV	54.00	7.80	1.00 H	28	33.60	37.2	10.20	-34.8	12.60

ANTENNA POLARITY & TEST DISTANCE: VERTICAL AT 3 M

No.	Frequency (MHz)	Emission Level (dBuV/m)	Limit (dBuV/m)	Margin (dB)	Antenna Height (m)	Table Angle (Degree)	Raw Value (dBuV)	Antenna Factor (dB/m)	Cable Factor (dB)	Pre-amplifier (dB)	Correction Factor (dB/m)
1	*2437.00	106.70 PK			1.00 V	121	109.90	28.3	5.10	-36.6	-3.20
1	*2437.00	92.20 AV			1.00 V	121	94.40	28.3	5.10	-36.6	-3.20
2	4874.00	47.00 PK	74.00	27.00	1.00 V	97	43.60	32.3	7.60	-36.5	3.40
2	4874.00	36.10 AV	54.00	17.90	1.00 V	97	33.10	32.3	7.60	-36.5	3.40
3	7311.00	55.10 PK	74.00	22.90	1.00 V	288	45.70	36.1	8.60	-35.3	9.40
3	7311.00	42.10 AV	54.00	11.90	1.00 V	288	32.70	36.1	8.60	-35.3	9.40
4	9748.00	55.30 PK	74.00	18.70	1.00 V	89	42.70	37.2	10.20	-34.8	12.60
4	9748.00	47.20 AV	54.00	6.80	1.00 V	89	34.60	37.2	10.20	-34.8	12.60

- REMARKS:**
1. Emission level (dBuV/m)=Raw Value(dBuV) + Correction Factor(dB/m)
 2. Correction Factor (dB/m) = Antenna Factor (dB/m) + Cable Factor (dB))+ Pre-amplifier Factor
 3. The other emission levels were very low against the limit.
 4. Margin value = Limit value- Emission level.
 5. The limit value is defined as per 15.247
 6. "*" : Fundamental frequency
 7. For Wireless 802.11b mode at 11Mbps.

802.11b CH11

ANTENNA POLARITY & TEST DISTANCE: HORIZONTAL AT 3 M

No.	Frequency (MHz)	Emission Level (dBuV/m)	Limit (dBuV/m)	Margin (dB)	Antenna Height (m)	Table Angle (Degree)	Raw Value (dBuV)	Antenna Factor (dB/m)	Cable Factor (dB)	Pre-amplifier (dB)	Correction Factor (dB/m)
1	*2462.00	105.90 PK			1.00 H	154	109.20	28.6	4.70	-36.6	-3.30
1	*2462.00	93.70 AV			1.00 H	154	97.00	28.6	4.70	-36.6	-3.30
2	2483.50	38.70 PK	74.00	35.30	1.00 H	146	42.00	28.6	4.70	-36.6	-3.30
2	2483.50	28.10 AV	54.00	25.90	1.00 H	146	31.40	28.6	4.70	-36.6	-3.30
3	4022.04	45.20 PK	74.00	28.80	1.00 H	341	43.30	32.2	6.20	-36.5	1.90
3	4022.04	33.30 AV	54.00	20.70	1.00 H	341	31.40	32.2	6.20	-36.5	1.90
4	4924.00	46.10 PK	74.00	27.90	1.00 H	100	42.30	33.0	7.00	-36.2	3.80
4	4924.00	35.10 AV	54.00	18.90	1.00 H	100	31.30	33.0	7.00	-36.2	3.80
5	7386.00	55.40 PK	74.00	18.60	1.00 H	190	46.00	36.2	8.50	-35.3	9.40
5	7386.00	42.30 AV	54.00	11.70	1.00 H	190	32.90	36.2	8.50	-35.3	9.40
6	9848.00	59.00 PK	74.00	15.00	1.00 H	113	46.40	37.2	10.20	-34.8	12.60
6	9848.00	48.40 AV	54.00	5.60	1.00 H	113	35.80	37.2	10.20	-34.8	12.60

ANTENNA POLARITY & TEST DISTANCE: VERTICAL AT 3 M

No.	Frequency (MHz)	Emission Level (dBuV/m)	Limit (dBuV/m)	Margin (dB)	Antenna Height (m)	Table Angle (Degree)	Raw Value (dBuV)	Antenna Factor (dB/m)	Cable Factor (dB)	Pre-amplifier (dB)	Correction Factor (dB/m)
1	*2462.00	106.90 PK			1.00 V	247	110.20	28.6	4.70	-36.6	-3.30
1	*2462.00	96.60 AV			1.00 V	247	99.90	28.6	4.70	-36.6	-3.30
2	2483.50	53.40 PK	74.00	20.60	1.00 V	150	56.70	28.6	4.70	-36.6	-3.30
2	2483.50	42.80 AV	54.00	11.20	1.00 V	150	46.10	28.6	4.70	-36.6	-3.30
3	4022.04	45.10 PK	74.00	28.90	1.00 V	299	43.20	32.2	6.20	-36.5	1.90
3	4022.04	35.30 AV	54.00	18.70	1.00 V	299	32.40	32.2	6.20	-36.5	1.90
4	4924.00	46.40 PK	74.00	27.60	1.00 V	90	42.60	33.0	7.00	-36.2	3.80
4	4924.00	37.10 AV	54.00	16.90	1.00 V	90	33.30	33.0	7.00	-36.2	3.80
5	7386.00	55.00 PK	74.00	19.00	1.00 V	29	45.60	36.2	8.50	-35.3	9.40
5	7386.00	44.60 AV	54.00	9.40	1.00 V	29	35.20	36.2	8.50	-35.3	9.40
6	9848.00	58.30 PK	74.00	15.70	1.00 V	222	45.70	37.2	10.20	-34.8	12.60
6	9848.00	49.10 AV	54.00	4.90	1.00 V	222	36.50	37.2	10.20	-34.8	12.60

- REMARKS:**
1. Emission level (dBuV/m)=Raw Value(dBuV) + Correction Factor(dB/m)
 2. Correction Factor (dB/m) = Antenna Factor (dB/m) + Cable Factor (dB))+ Pre-amplifier Factor
 3. The other emission levels were very low against the limit.
 4. Margin value = Limit value- Emission level.
 5. The limit value is defined as per 15.247
 6. "*" : Fundamental frequency
 7. For Wireless 802.11b mode at 11Mbps.

802.11g CH1

ANTENNA POLARITY & TEST DISTANCE: HORIZONTAL AT 3 M

No.	Frequency (MHz)	Emission Level (dBuV/m)		Limit (dBuV/m)	Margin (dB)	Antenna Height (m)	Table Angle (Degree)	Raw Value (dBuV)	Antenna Factor (dB/m)	Cable Factor (dB)	Pre-amplifier (dB)	Correction Factor (dB/m)
1	2390.00	60.83	PK	74.00	13.17	1.00 H	247	64.13	28.3	5.00	36.6	-3.30
1	2390.00	41.22	AV	54.00	12.78	1.00 H	247	44.52	28.3	5.00	36.6	-3.30
2	*2412.00	104.36	PK			1.00 H	100	107.66	28.3	5.00	36.6	-3.30
2	*2412.00	90.53	AV			1.00 H	100	93.83	28.3	5.00	36.6	-3.30
3	4824.00	51.23	PK	74.00	22.77	1.00 H	89	47.43	32.7	7.30	36.2	3.80
3	4824.00	37.88	AV	54.00	16.12	1.00 H	89	34.08	32.7	7.30	36.2	3.80
4	7236.00	57.00	PK	74.00	17.00	1.00 H	345	47.60	35.8	8.90	35.3	9.40
4	7236.00	40.13	AV	54.00	13.87	1.00 H	345	30.73	35.8	8.90	35.3	9.40
5	9648.00	52.55	PK	74.00	21.45	1.00 H	121	39.95	37.2	10.20	34.8	12.60
5	9648.00	39.78	AV	54.00	14.22	1.00 H	121	27.18	37.2	10.20	34.8	12.60

ANTENNA POLARITY & TEST DISTANCE: VERTICAL AT 3 M

No.	Frequency (MHz)	Emission Level (dBuV/m)		Limit (dBuV/m)	Margin (dB)	Antenna Height (m)	Table Angle (Degree)	Raw Value (dBuV)	Antenna Factor (dB/m)	Cable Factor (dB)	Pre-amplifier (dB)	Correction Factor (dB/m)
1	2390.00	67.55	PK	74.00	6.450	1.00 V	288	70.85	28.3	5.00	36.6	-3.30
1	2390.00	40.25	AV	54.00	13.75	1.00 V	288	43.55	28.3	5.00	36.6	-3.30
2	*2412.00	103.29	PK			1.00 V	69	106.59	28.3	5.00	36.6	-3.30
2	*2412.00	91.24	AV			1.00 V	69	94.54	28.3	5.00	36.6	-3.30
3	4824.00	53.54	PK	74.00	20.46	1.00 V	291	49.74	32.7	7.30	36.2	3.80
3	4824.00	40.12	AV	54.00	13.88	1.00 V	291	36.32	32.7	7.30	36.2	3.80
4	7236.00	62.45	PK	74.00	11.55	1.00 V	360	53.05	35.8	8.90	35.3	9.40
4	7236.00	42.77	AV	54.00	11.23	1.00 V	360	33.37	35.8	8.90	35.3	9.40
5	9648.00	55.68	PK	74.00	18.32	1.00 V	155	43.08	37.2	10.20	34.8	12.60
5	9648.00	40.44	AV	54.00	13.56	1.00 V	155	27.84	37.2	10.20	34.8	12.60

- REMARKS:**
1. Emission level (dBuV/m)=Raw Value(dBuV) + Correction Factor(dB/m)
 2. Correction Factor (dB/m) = Antenna Factor (dB/m) + Cable Factor (dB))+ Pre-amplifier Factor
 3. The other emission levels were very low against the limit.
 4. Margin value = Limit value- Emission level.
 5. The limit value is defined as per 15.247
 6. "*" : Fundamental frequency
 7. For Wireless 802.11g mode at 54Mbps.

802.11g CH6

ANTENNA POLARITY & TEST DISTANCE: HORIZONTAL AT 3 M

No.	Frequency (MHz)	Emission Level (dBuV/m)	Limit (dBuV/m)	Margin (dB)	Antenna Height (m)	Table Angle (Degree)	Raw Value (dBuV)	Antenna Factor (dB/m)	Cable Factor (dB)	Pre-amplifier (dB)	Correction Factor (dB/m)
1	*2437.00	107.40 PK			1.00 H	100	109.60	28.3	5.10	-36.6	-3.20
1	*2437.00	89.00 AV			1.00 H	100	92.20	28.3	5.10	-36.6	-3.20
2	4874.00	45.40 PK	74.00	28.60	1.00 H	214	42.00	32.8	7.10	-36.5	3.40
2	4874.00	37.10 AV	54.00	17.90	1.00 H	214	32.70	32.8	7.10	-36.5	3.40
3	7311.00	52.70 PK	74.00	21.30	1.00 H	0	43.30	36.1	8.60	-35.3	9.40
3	7311.00	45.30 AV	54.00	8.70	1.00 H	0	35.90	36.1	8.60	-35.3	9.40
4	9748.00	55.80 PK	74.00	18.20	1.00 H	163	43.20	37.2	10.20	-34.8	12.60
4	9748.00	46.30 AV	54.00	7.70	1.00 H	163	33.70	37.2	10.20	-34.8	12.60

ANTENNA POLARITY & TEST DISTANCE: VERTICAL AT 3 M

No.	Frequency (MHz)	Emission Level (dBuV/m)	Limit (dBuV/m)	Margin (dB)	Antenna Height (m)	Table Angle (Degree)	Raw Value (dBuV)	Antenna Factor (dB/m)	Cable Factor (dB)	Pre-amplifier (dB)	Correction Factor (dB/m)
1	*2437.00	105.50 PK			1.00 V	122	108.70	28.3	5.10	-36.6	-3.20
1	*2437.00	95.80 AV			1.00 V	122	99.00	28.3	5.10	-36.6	-3.20
2	4874.00	45.10 PK	74.00	28.90	1.00 V	100	41.70	32.8	7.10	-36.5	3.40
2	4874.00	37.10 AV	54.00	16.90	1.00 V	100	33.70	32.8	7.10	-36.5	3.40
3	7311.00	54.90 PK	74.00	19.10	1.00 V	356	45.50	36.1	8.60	-35.3	9.40
3	7311.00	45.40 AV	54.00	8.60	1.00 V	356	36.00	36.1	8.60	-35.3	9.40
4	9748.00	56.60 PK	74.00	17.40	1.00 V	26	44.00	37.2	10.20	-34.8	12.60
4	9748.00	48.20 AV	54.00	7.80	1.00 V	26	35.60	37.2	10.20	-34.8	12.60

- REMARKS:**
1. Emission level (dBuV/m) = Raw Value (dBuV) + Correction Factor (dB/m)
 2. Correction Factor (dB/m) = Antenna Factor (dB/m) + Cable Factor (dB) + Pre-amplifier Factor
 3. The other emission levels were very low against the limit.
 4. Margin value = Limit value - Emission level.
 5. The limit value is defined as per 15.247
 6. "*" : Fundamental frequency
 7. For Wireless 802.11g mode at 54Mbps.

802.11g CH11

ANTENNA POLARITY & TEST DISTANCE: HORIZONTAL AT 3 M

No.	Frequency (MHz)	Emission Level (dBuV/m)	Limit (dBuV/m)	Margin (dB)	Antenna Height (m)	Table Angle (Degree)	Raw Value (dBuV)	Antenna Factor (dB/m)	Cable Factor (dB)	Pre-amplifier (dB)	Correction Factor (dB/m)
1	*2462.00	97.50 PK			1.00 H	156	100.80	28.2	5.10	-36.6	-3.30
1	*2462.00	82.80 AV			1.00 H	156	86.10	28.2	5.10	-36.6	-3.30
2	2483.50	46.70 PK	74.00	27.30	1.00 H	191	50.00	28.2	5.10	-36.6	-3.30
2	2483.50	37.10 AV	54.00	16.90	1.00 H	191	40.40	28.2	5.10	-36.6	-3.30
3	4924.00	46.90 PK	74.00	27.10	1.00 H	198	43.10	33.0	7.00	-36.2	3.80
3	4924.00	36.90 AV	54.00	17.10	1.00 H	198	33.10	33.0	7.00	-36.2	3.80
4	7386.00	54.70 PK	74.00	19.30	1.00 H	90	45.30	36.2	8.50	-35.3	9.40
4	7386.00	48.30 AV	54.00	6.70	1.00 H	90	37.90	36.2	8.50	-35.3	9.40
5	9848.00	55.60 PK	74.00	18.40	1.00 H	124	43.00	37.3	10.10	-34.8	12.60
5	9848.00	45.20 AV	54.00	8.80	1.00 H	124	32.60	37.3	10.10	-34.8	12.60

ANTENNA POLARITY & TEST DISTANCE: VERTICAL AT 3 M

No.	Frequency (MHz)	Emission Level (dBuV/m)	Limit (dBuV/m)	Margin (dB)	Antenna Height (m)	Table Angle (Degree)	Raw Value (dBuV)	Antenna Factor (dB/m)	Cable Factor (dB)	Pre-amplifier (dB)	Correction Factor (dB/m)
1	*2462.00	101.50 PK			1.00 V	125	105.80	28.2	5.10	-36.6	-3.30
1	*2462.00	89.10 AV			1.00 V	125	94.40	28.2	5.10	-36.6	-3.30
2	2483.50	66.70 PK	74.00	8.30	1.00 V	348	69.00	28.2	5.10	-36.6	-3.30
2	2483.50	50.90 AV	54.00	3.10	1.00 V	348	54.20	28.2	5.10	-36.6	-3.30
3	4924.00	45.10 PK	74.00	28.90	1.00 V	96	41.30	33.0	7.00	-36.2	3.80
3	4924.00	35.80 AV	54.00	18.20	1.00 V	96	32.00	33.0	7.00	-36.2	3.80
4	7386.00	56.40 PK	74.00	17.60	1.00 V	35	47.00	36.2	8.50	-35.3	9.40
4	7386.00	42.30 AV	54.00	11.70	1.00 V	35	32.90	36.2	8.50	-35.3	9.40
5	9848.00	53.60 PK	74.00	20.40	1.00 V	37	45.00	37.3	10.10	-34.8	12.60
5	9848.00	46.20 AV	54.00	7.80	1.00 V	37	33.60	37.3	10.10	-34.8	12.60

- REMARKS:**
1. Emission level (dBuV/m) = Raw Value (dBuV) + Correction Factor (dB/m)
 2. Correction Factor (dB/m) = Antenna Factor (dB/m) + Cable Factor (dB) + Pre-amplifier Factor
 3. The other emission levels were very low against the limit.
 4. Margin value = Limit value - Emission level.
 5. The limit value is defined as per 15.247
 6. " * " : Fundamental frequency
 7. For Wireless 802.11g mode at 54Mbps.

802.11n (20MHz) Channel 1

ANTENNA POLARITY & TEST DISTANCE: HORIZONTAL AT 3 M

No.	Frequency (MHz)	Emission Level (dBuV/m)		Limit (dBuV/m)	Margin (dB)	Antenna Height (m)	Table Angle (Degree)	Raw Value (dBuV)	Antenna Factor (dB/m)	Cable Factor (dB)	Pre-amplifier (dB)	Correction Factor (dB/m)
1	2390.00	65.10	PK	74.00	8.90	1.00 H	144	68.40	28.3	5.00	36.6	-3.30
1	2390.00	35.50	AV	54.00	18.50	1.00 H	144	38.80	28.3	5.00	36.6	-3.30
2	*2412.00	101.43	PK			1.00 H	256	104.73	28.3	5.00	36.6	-3.30
2	*2412.00	81.00	AV			1.00 H	256	84.30	28.3	5.00	36.6	-3.30
3	4824.00	54.23	PK	74.00	19.77	1.00 H	88	50.43	32.7	7.30	36.2	3.80
3	4824.00	44.47	AV	54.00	9.53	1.00 H	88	40.67	32.7	7.30	36.2	3.80
4	7236.00	55.88	PK	74.00	18.12	1.00 H	331	46.48	35.8	8.90	35.3	9.40
4	7236.00	45.26	AV	54.00	8.74	1.00 H	331	35.86	35.8	8.90	35.3	9.40
5	9648.00	55.14	PK	74.00	18.86	1.00 H	105	42.54	37.2	10.20	34.8	12.60
5	9648.00	43.69	AV	54.00	10.31	1.00 H	105	31.09	37.2	10.20	34.8	12.60

ANTENNA POLARITY & TEST DISTANCE: VERTICAL AT 3 M

No.	Frequency (MHz)	Emission Level (dBuV/m)		Limit (dBuV/m)	Margin (dB)	Antenna Height (m)	Table Angle (Degree)	Raw Value (dBuV)	Antenna Factor (dB/m)	Cable Factor (dB)	Pre-amplifier (dB)	Correction Factor (dB/m)
1	2390.00	66.01	PK	74.00	7.99	1.00 V	125	69.31	28.3	5.00	36.6	-3.30
1	2390.00	45.27	AV	54.00	8.73	1.00 V	125	48.57	28.3	5.00	36.6	-3.30
2	*2412.00	101.40	PK			1.00 V	236	104.70	28.3	5.00	36.6	-3.30
2	*2412.00	82.72	AV			1.00 V	236	85.02	28.3	5.00	36.6	-3.30
3	4824.00	54.39	PK	74.00	19.61	1.00 V	179	50.59	32.7	7.30	36.2	3.80
3	4824.00	44.07	AV	54.00	9.93	1.00 V	179	40.27	32.7	7.30	36.2	3.80
4	7236.00	54.51	PK	74.00	19.49	1.00 V	313	45.11	35.8	8.90	35.3	9.40
4	7236.00	45.56	AV	54.00	8.44	1.00 V	313	36.16	35.8	8.90	35.3	9.40
5	9648.00	56.71	PK	74.00	17.29	1.00 V	5	44.11	37.2	10.20	34.8	12.60
5	9648.00	41.25	AV	54.00	12.75	1.00 V	5	28.65	37.2	10.20	34.8	12.60

- REMARKS:**
1. Emission level (dBuV/m)=Raw Value(dBuV) + Correction Factor(dB/m)
 2. Correction Factor (dB/m) = Antenna Factor (dB/m) + Cable Factor (dB) -Pre-amplifier Factor
 3. The other emission levels were very low against the limit.
 4. Margin value = Limit value- Emission level.
 5. The limit value is defined as per 15.247
 6. "*" : Fundamental frequency

802.11n (20MHz) Channel 6

ANTENNA POLARITY & TEST DISTANCE: HORIZONTAL AT 3 M

No.	Frequency (MHz)	Emission Level (dBuV/m)		Limit (dBuV/m)	Margin (dB)	Antenna Height (m)	Table Angle (Degree)	Raw Value (dBuV)	Antenna Factor (dB/m)	Cable Factor (dB)	Pre-amplifier (dB)	Correction Factor (dB/m)
1	*2437.00	100.88	PK			1.00 H	223	104.08	28.3	5.10	36.6	-3.20
1	*2437.00	86.07	AV			1.00 H	122	89.27	28.3	5.10	36.6	-3.20
2	4874.00	47.56	PK	74.00	26.44	1.00 H	5	44.16	32.8	7.10	36.5	3.40
2	4874.00	36.91	AV	54.00	17.09	1.00 H	5	33.51	32.8	7.10	36.5	3.40
3	7311.00	53.72	PK	74.00	20.28	1.00 H	124	44.32	36.1	8.60	35.3	9.40
3	7311.00	40.66	AV	54.00	13.34	1.00 H	124	31.26	36.1	8.60	35.3	9.40
4	9748.00	53.78	PK	74.00	20.22	1.00 H	325	41.18	37.2	10.20	34.8	12.60
4	9748.00	42.04	AV	54.00	11.96	1.00 H	325	29.44	37.2	10.20	34.8	12.60

ANTENNA POLARITY & TEST DISTANCE: VERTICAL AT 3 M

No.	Frequency (MHz)	Emission Level (dBuV/m)		Limit (dBuV/m)	Margin (dB)	Antenna Height (m)	Table Angle (Degree)	Raw Value (dBuV)	Antenna Factor (dB/m)	Cable Factor (dB)	Pre-amplifier (dB)	Correction Factor (dB/m)
1	*2437.00	100.97	PK			1.00 V	125	104.17	28.3	5.10	36.6	-3.20
1	*2437.00	82.11	AV			1.00 V	125	85.31	28.3	5.10	36.6	-3.20
2	4874.00	48.23	PK	74.00	25.77	1.00 V	289	44.83	32.8	7.10	36.5	3.40
2	4874.00	36.97	AV	54.00	17.03	1.00 V	289	33.57	32.8	7.10	36.5	3.40
3	7311.00	52.46	PK	74.00	21.54	1.00 V	0	43.06	36.1	8.60	35.3	9.40
3	7311.00	40.57	AV	54.00	13.43	1.00 V	0	31.17	36.1	8.60	35.3	9.40
4	9748.00	52.36	PK	74.00	21.64	1.00 V	180	39.76	37.2	10.20	34.8	12.60
4	9748.00	42.89	AV	54.00	11.11	1.00 V	180	30.29	37.2	10.20	34.8	12.60

- REMARKS:**
1. Emission level (dBuV/m) = Raw Value (dBuV) + Correction Factor (dB/m)
 2. Correction Factor (dB/m) = Antenna Factor (dB/m) + Cable Factor (dB) - Pre-amplifier Factor
 3. The other emission levels were very low against the limit.
 4. Margin value = Limit value - Emission level.
 5. The limit value is defined as per 15.247
 6. "*" : Fundamental frequency

802.11n (20MHz) Channel 11

ANTENNA POLARITY & TEST DISTANCE: HORIZONTAL AT 3 M

No.	Frequency (MHz)	Emission Level (dBuV/m)		Limit (dBuV/m)	Margin (dB)	Antenna Height (m)	Table Angle (Degree)	Raw Value (dBuV)	Antenna Factor (dB/m)	Cable Factor (dB)	Pre-amplifier (dB)	Correction Factor (dB/m)
1	*2462.00	95.84	PK			1.00 H	122	99.14	28.2	5.10	36.6	-3.30
1	*2462.00	85.73	AV			1.00 H	122	89.03	28.2	5.10	36.6	-3.30
2	2483.50	47.50	PK	74.00	26.50	1.00 H	300	50.80	28.2	5.10	36.6	-3.30
2	2483.50	38.65	AV	54.00	15.35	1.00 H	300	41.95	28.2	5.10	36.6	-3.30
3	4924.00	49.28	PK	74.00	24.72	1.00 H	156	45.48	33.0	7.00	36.2	3.80
3	4924.00	37.00	AV	54.00	17.00	1.00 H	156	33.20	33.0	7.00	36.2	3.80
4	7386.00	50.36	PK	74.00	23.64	1.00 H	334	40.96	36.2	8.50	35.3	9.40
4	7386.00	42.12	AV	54.00	11.88	1.00 H	334	32.72	36.2	8.50	35.3	9.40
5	9848.00	54.17	PK	74.00	19.83	1.00 H	278	41.57	37.3	10.10	34.8	12.60
5	9848.00	40.23	AV	54.00	13.77	1.00 H	278	27.63	37.3	10.10	34.8	12.60

ANTENNA POLARITY & TEST DISTANCE: VERTICAL AT 3 M

No.	Frequency (MHz)	Emission Level (dBuV/m)		Limit (dBuV/m)	Margin (dB)	Antenna Height (m)	Table Angle (Degree)	Raw Value (dBuV)	Antenna Factor (dB/m)	Cable Factor (dB)	Pre-amplifier (dB)	Correction Factor (dB/m)
1	*2462.00	100.54	PK			1.00 V	125	103.84	28.2	5.10	36.6	-3.30
1	*2462.00	85.32	AV			1.00 V	125	88.62	28.2	5.10	36.6	-3.30
2	2483.50	58.08	PK	74.00	15.92	1.00 V	189	61.38	28.2	5.10	36.6	-3.30
2	2483.50	40.91	AV	54.00	13.09	1.00 V	189	44.21	28.2	5.10	36.6	-3.30
3	4924.00	54.12	PK	74.00	19.88	1.00 V	347	50.32	33.0	7.00	36.2	3.80
3	4924.00	36.17	AV	54.00	17.83	1.00 V	347	32.37	33.0	7.00	36.2	3.80
4	7386.00	54.12	PK	74.00	19.88	1.00 V	12	44.72	36.2	8.50	35.3	9.40
4	7386.00	40.54	AV	54.00	13.46	1.00 V	12	31.14	36.2	8.50	35.3	9.40
5	9848.00	54.10	PK	74.00	19.90	1.00 V	208	41.50	37.3	10.10	34.8	12.60
5	9848.00	41.23	AV	54.00	12.77	1.00 V	208	28.63	37.3	10.10	34.8	12.60

- REMARKS:**
1. Emission level (dBuV/m) = Raw Value (dBuV) + Correction Factor (dB/m)
 2. Correction Factor (dB/m) = Antenna Factor (dB/m) + Cable Factor (dB) - Pre-amplifier Factor
 3. The other emission levels were very low against the limit.
 4. Margin value = Limit value - Emission level.
 5. The limit value is defined as per 15.247
 6. " * " : Fundamental frequency

802.11n (40MHz) Channel 3

ANTENNA POLARITY & TEST DISTANCE: HORIZONTAL AT 3 M

No.	Frequency (MHz)	Emission Level (dBuV/m)		Limit (dBuV/m)	Margin (dB)	Antenna Height (m)	Table Angle (Degree)	Raw Value (dBuV)	Antenna Factor (dB/m)	Cable Factor (dB)	Pre-amplifier (dB)	Correction Factor (dB/m)
1	2390.00	66.16	PK	74.00	7.84	1.00 H	236	69.46	28.3	5.00	36.6	-3.30
1	2390.00	39.13	AV	54.00	14.87	1.00 H	236	42.43	28.3	5.00	36.6	-3.30
2	*2422.00	101.03	PK			1.00 H	100	104.33	28.3	5.00	36.6	-3.30
2	*2422.00	84.21	AV			1.00 H	100	87.51	28.3	5.00	36.6	-3.30
3	4844.00	50.88	PK	74.00	23.12	1.00 H	197	47.08	32.7	7.30	36.2	3.80
3	4844.00	42.26	AV	54.00	11.74	1.00 H	197	38.46	32.7	7.30	36.2	3.80
4	7266.00	53.00	PK	74.00	21.00	1.00 H	306	43.60	35.8	8.90	35.3	9.40
4	7266.00	41.08	AV	54.00	12.92	1.00 H	306	31.68	35.8	8.90	35.3	9.40
5	9688.00	55.72	PK	74.00	18.28	1.00 H	17	43.12	37.2	10.20	34.8	12.60
5	9688.00	42.25	AV	54.00	11.75	1.00 H	17	29.65	37.2	10.20	34.8	12.60

ANTENNA POLARITY & TEST DISTANCE: VERTICAL AT 3 M

No.	Frequency (MHz)	Emission Level (dBuV/m)		Limit (dBuV/m)	Margin (dB)	Antenna Height (m)	Table Angle (Degree)	Raw Value (dBuV)	Antenna Factor (dB/m)	Cable Factor (dB)	Pre-amplifier (dB)	Correction Factor (dB/m)
1	2390.00	65.89	PK	74.00	8.11	1.00 V	122	69.19	28.3	5.00	36.6	-3.30
1	2390.00	40.06	AV	54.00	13.94	1.00 V	122	43.36	28.3	5.00	36.6	-3.30
2	*2422.00	101.44	PK			1.00 V	189	104.74	28.3	5.00	36.6	-3.30
2	*2422.00	83.93	AV			1.00 V	189	87.23	28.3	5.00	36.6	-3.30
3	4844.00	52.77	PK	74.00	21.23	1.00 V	257	48.97	32.7	7.30	36.2	3.80
3	4844.00	40.03	AV	54.00	13.97	1.00 V	257	36.23	32.7	7.30	36.2	3.80
4	7266.00	53.89	PK	74.00	20.11	1.00 V	155	44.49	35.8	8.90	35.3	9.40
4	7266.00	41.56	AV	54.00	12.44	1.00 V	155	32.16	35.8	8.90	35.3	9.40
5	9688.00	55.99	PK	74.00	18.01	1.00 V	334	43.39	37.2	10.20	34.8	12.60
5	9688.00	43.14	AV	54.00	10.86	1.00 V	334	30.54	37.2	10.20	34.8	12.60

- REMARKS:**
1. Emission level (dBuV/m)=Raw Value(dBuV) + Correction Factor(dB/m)
 2. Correction Factor (dB/m) = Antenna Factor (dB/m) + Cable Factor (dB) -Pre-amplifier Factor
 3. The other emission levels were very low against the limit.
 4. Margin value = Limit value- Emission level.
 5. The limit value is defined as per 15.247
 6. "*" : Fundamental frequency

802.11n (40MHz) Channel 6

ANTENNA POLARITY & TEST DISTANCE: HORIZONTAL AT 3 M

No.	Frequency (MHz)	Emission Level (dBuV/m)		Limit (dBuV/m)	Margin (dB)	Antenna Height (m)	Table Angle (Degree)	Raw Value (dBuV)	Antenna Factor (dB/m)	Cable Factor (dB)	Pre-amplifier (dB)	Correction Factor (dB/m)
1	*2437.00	99.15	PK			1.00 H	100	102.35	28.3	5.10	36.6	-3.20
1	*2437.00	84.36	AV			1.00 H	100	87.56	28.3	5.10	36.6	-3.20
2	4874.00	49.11	PK	74.00	24.89	1.00 H	198	45.71	32.3	7.60	36.5	3.40
2	4874.00	38.82	AV	54.00	15.18	1.00 H	198	35.42	32.3	7.60	36.5	3.40
3	7311.00	52.22	PK	74.00	21.78	1.00 H	203	42.82	36.1	8.60	35.3	9.40
3	7311.00	41.00	AV	54.00	13.00	1.00 H	203	31.60	36.1	8.60	35.3	9.40
4	9748.00	53.91	PK	74.00	20.09	1.00 H	56	41.31	37.2	10.20	34.8	12.60
4	9748.00	42.17	AV	54.00	11.83	1.00 H	56	29.57	37.2	10.20	34.8	12.60

ANTENNA POLARITY & TEST DISTANCE: VERTICAL AT 3 M

No.	Frequency (MHz)	Emission Level (dBuV/m)		Limit (dBuV/m)	Margin (dB)	Antenna Height (m)	Table Angle (Degree)	Raw Value (dBuV)	Antenna Factor (dB/m)	Cable Factor (dB)	Pre-amplifier (dB)	Correction Factor (dB/m)
1	*2437.00	101.14	PK			1.00 V	122	104.34	28.3	5.10	36.6	-3.20
1	*2437.00	86.51	AV			1.00 V	122	89.71	28.3	5.10	36.6	-3.20
2	4874.00	49.99	PK	74.00	24.01	1.00 V	96	46.59	32.3	7.60	36.5	3.40
2	4874.00	38.97	AV	54.00	15.03	1.00 V	96	35.57	32.3	7.60	36.5	3.40
3	7311.00	54.36	PK	74.00	19.64	1.00 V	26	44.96	36.1	8.60	35.3	9.40
3	7311.00	40.57	AV	54.00	13.43	1.00 V	26	31.17	36.1	8.60	35.3	9.40
4	9748.00	52.79	PK	74.00	21.21	1.00 V	299	40.19	37.2	10.20	34.8	12.60
4	9748.00	42.07	AV	54.00	11.93	1.00 V	299	29.47	37.2	10.20	34.8	12.60

- REMARKS:**
1. Emission level (dBuV/m) = Raw Value (dBuV) + Correction Factor (dB/m)
 2. Correction Factor (dB/m) = Antenna Factor (dB/m) + Cable Factor (dB) - Pre-amplifier Factor
 3. The other emission levels were very low against the limit.
 4. Margin value = Limit value - Emission level.
 5. The limit value is defined as per 15.247
 6. "*" : Fundamental frequency

802.11n (40MHz) Channel 9

ANTENNA POLARITY & TEST DISTANCE: HORIZONTAL AT 3 M

No.	Frequency (MHz)	Emission Level (dBuV/m)		Limit (dBuV/m)	Margin (dB)	Antenna Height (m)	Table Angle (Degree)	Raw Value (dBuV)	Antenna Factor (dB/m)	Cable Factor (dB)	Pre-amplifier (dB)	Correction Factor (dB/m)
1	*2452.00	95.09	PK			1.00 H	125	98.29	28.2	5.20	36.6	-3.20
1	*2452.00	83.71	AV			1.00 H	125	85.91	28.2	5.20	36.6	-3.20
2	2483.50	54.61	PK	74.00	19.39	1.00 H	312	57.91	28.2	5.10	36.6	-3.30
2	2483.50	39.24	AV	54.00	14.76	1.00 H	312	42.54	28.2	5.10	36.6	-3.30
3	4904.00	49.97	PK	74.00	24.03	1.00 H	258	46.17	33.0	7.00	36.2	3.80
3	4904.00	35.67	AV	54.00	18.33	1.00 H	258	31.87	33.0	7.00	36.2	3.80
4	7356.00	51.12	PK	74.00	22.88	1.00 H	12	41.72	36.2	8.50	35.3	9.40
4	7356.00	39.99	AV	54.00	14.01	1.00 H	12	30.59	36.2	8.50	35.3	9.40
5	9808.00	52.72	PK	74.00	21.28	1.00 H	100	40.12	37.3	10.10	34.8	12.60
5	9808.00	41.23	AV	54.00	12.77	1.00 H	100	28.63	37.3	10.10	34.8	12.60

ANTENNA POLARITY & TEST DISTANCE: VERTICAL AT 3 M

No.	Frequency (MHz)	Emission Level (dBuV/m)		Limit (dBuV/m)	Margin (dB)	Antenna Height (m)	Table Angle (Degree)	Raw Value (dBuV)	Antenna Factor (dB/m)	Cable Factor (dB)	Pre-amplifier (dB)	Correction Factor (dB/m)
1	*2452.00	100.99	PK			1.00 V	125	104.19	28.2	5.20	36.6	-3.20
1	*2452.00	84.50	AV			1.00 V	125	87.70	28.2	5.20	36.6	-3.20
2	2483.50	61.38	PK	74.00	12.62	1.00 V	300	64.68	28.2	5.10	36.6	-3.30
2	2483.50	39.63	AV	54.00	14.37	1.00 V	300	42.93	28.2	5.10	36.6	-3.30
3	4904.00	53.56	PK	74.00	20.44	1.00 V	346	49.76	33.0	7.00	36.2	3.80
3	4904.00	37.15	AV	54.00	16.85	1.00 V	346	33.35	33.0	7.00	36.2	3.80
4	7356.00	54.99	PK	74.00	19.01	1.00 V	157	45.59	36.2	8.50	35.3	9.40
4	7356.00	41.47	AV	54.00	12.53	1.00 V	157	32.07	36.2	8.50	35.3	9.40
5	9808.00	55.51	PK	74.00	18.49	1.00 V	287	42.91	37.3	10.10	34.8	12.60
5	9808.00	42.12	AV	54.00	11.88	1.00 V	287	29.52	37.3	10.10	34.8	12.60

- REMARKS:**
1. Emission level (dBuV/m) = Raw Value (dBuV) + Correction Factor (dB/m)
 2. Correction Factor (dB/m) = Antenna Factor (dB/m) + Cable Factor (dB) - Pre-amplifier Factor
 3. The other emission levels were very low against the limit.
 4. Margin value = Limit value - Emission level.
 5. The limit value is defined as per 15.247
 6. " * " : Fundamental frequency

Note:

The field strength is calculated by adding the Antenna Factor, Cable Factor & Pre-amplifier. The basic equation with a sample calculation is as follows:

Final Test Level = Receiver Reading + Antenna Factor + Cable Factor - Pre-amplifier Factor.

Remark: No any other emissions level which are attenuated less than 20dB below the limit

According to 15.31(o), The amplitude of spurious emissions from intentional radiators and emissions from unintentional radiators which are attenuated more than 20 dB below the permissible value need not be reported unless specifically required elsewhere in this Part.

Hence there no other emissions have been reported.

According to 15.31(o), The amplitude of spurious emissions from intentional radiators and emissions from unintentional radiators which are attenuated more than 20 dB below the permissible value need not be reported unless specifically required elsewhere in this Part.

Hence there no other emissions have been reported.

Remark:

- 1). As shown in Section, for frequencies above 1000 MHz. the above field strength limits are based on average limits. However, the peak field strength of any emission shall not exceed the maximum permitted average limits specified above by more than 20 dB under any condition of modulation.
- 2). The test only perform the EUT in transmitting status since the test frequencies were over 1GHz only required transmitting status.
- 3) Pre-Scan has been conducted to determine the worst-case mode from all possible Combinations between available modulations, data rates and antenna ports, and found the EUT worse case mode: 802.11b (11MHz), 802.11g (54MHz)
- 4) For this intentional radiator operates below 25 GHz. The spectrum shall be investigated to the tenth harmonic of the highest fundamental frequency. And above the 4th harmonic of this intentional radiator, the disturbance is very low. So the test result only displays to 4th harmonic.



4.3. 6dB Bandwidth Measurement

TEST CONFIGURATION

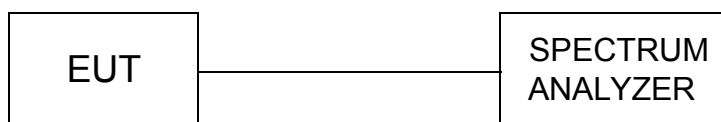

TEST PROCEDURE

1. The testing follows FCC KDB Publication No. 558074 (Measurement Guidelines of DTS).
2. The RF output of EUT was connected to the spectrum analyzer by a low loss cable.
3. Make the measurement with the spectrum analyzer's resolution bandwidth (RBW) = 100 kHz. In order to make an accurate measurement, set the span greater than RBW. The 6 dB bandwidth must be greater than 500 kHz.
4. The marker-delta reading at this point is the 6 dB bandwidth of the emission.

LIMIT

For digital modulation systems, the minimum 6 dB bandwidth shall be at least 500 kHz.

TEST RESULTS

Mode	CHANNEL	6 dB BANDWIDTH (MHz)	MINIMUM LIMIT (MHz)	PASS/FAIL
802.11b	1	12.00	0.5	PASS
	6	12.00	0.5	PASS
	11	11.80	0.5	PASS
802.11g	1	17.20	0.5	PASS
	6	17.20	0.5	PASS
	11	17.20	0.5	PASS
802.11n HT20	1	17.40	0.5	PASS
	6	17.40	0.5	PASS
	11	17.40	0.5	PASS
802.11n HT40	3	36.20	0.5	PASS
	6	36.40	0.5	PASS
	9	36.40	0.5	PASS

802.11b CH1 2412MHz

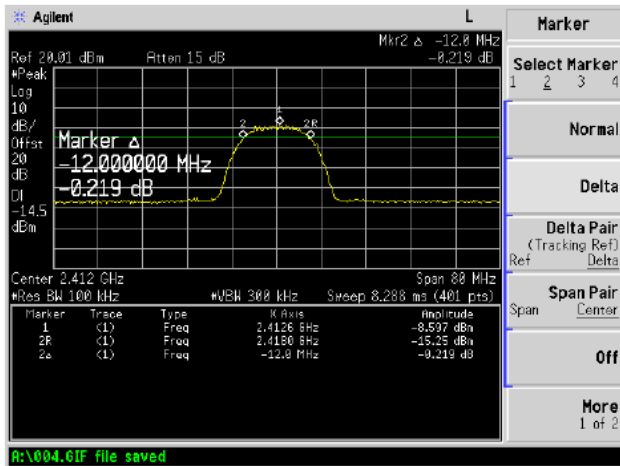

802.11g CH1 2412MHz

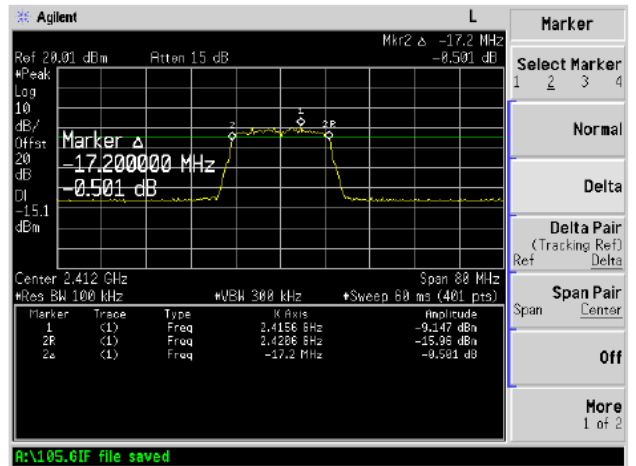

802.11b CH6 2437MHz

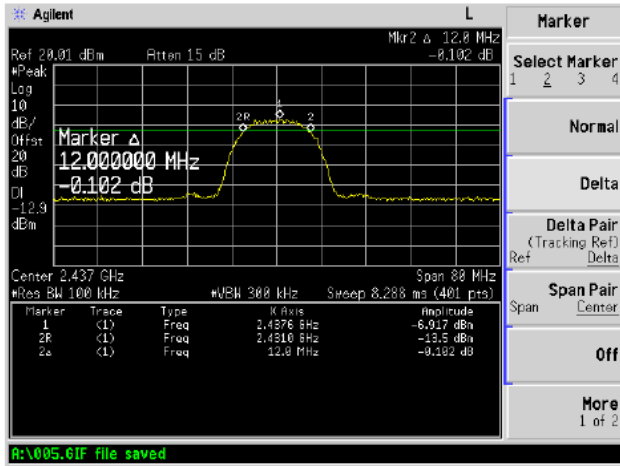

802.11g CH6 2437MHz

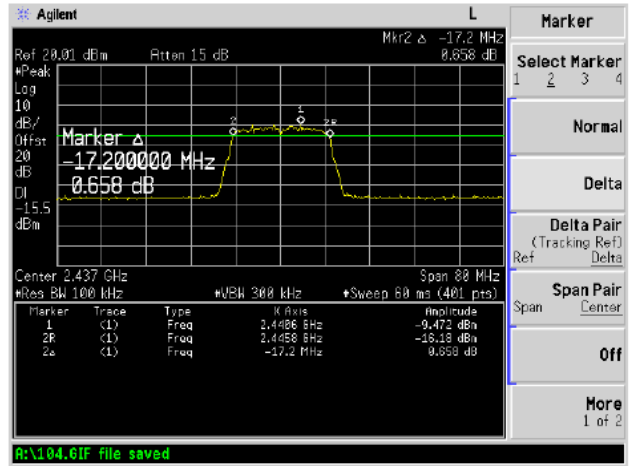

802.11b CH11 2462MHz

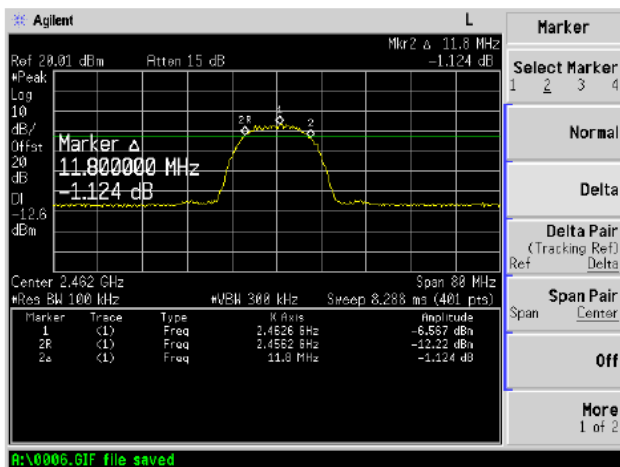

802.11g CH11 2462MHz

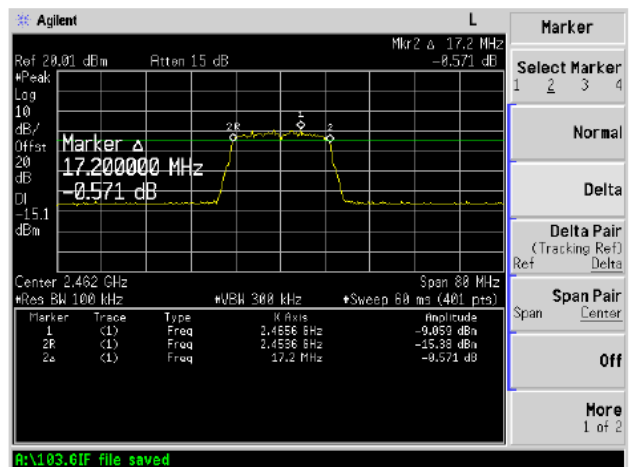

802.11n HT20 CH1 2412MHz

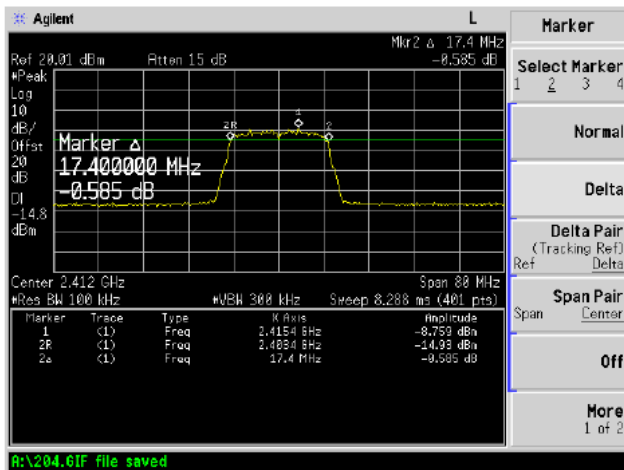

802.11n HT40 CH1 2422MHz

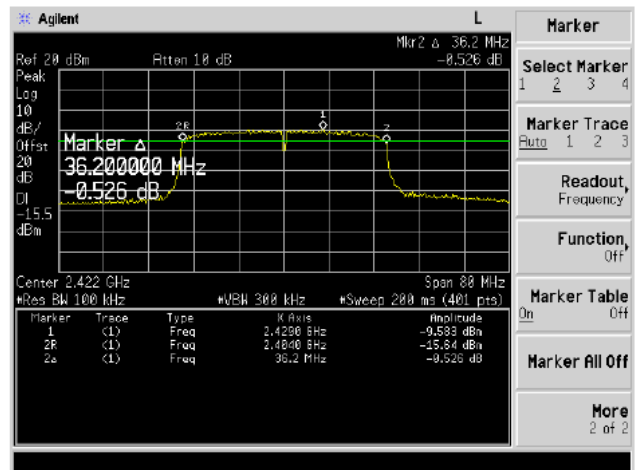

802.11 n HT20 CH6 2437MHz

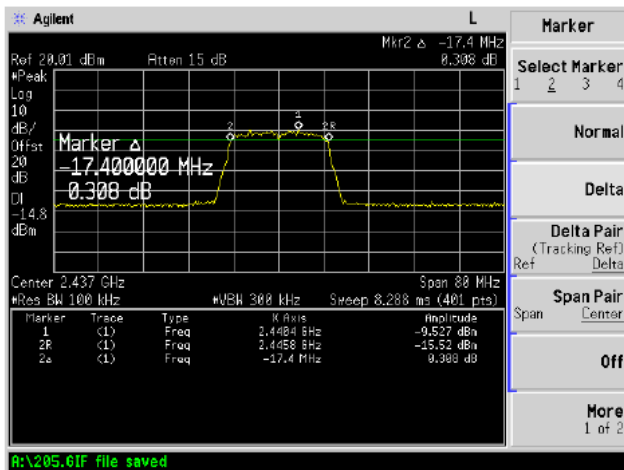

802.11 n HT40 CH4 2437MHz

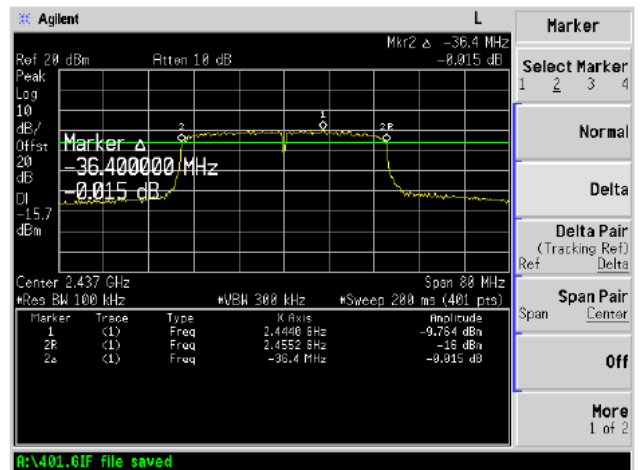

802.11 n HT20 CH11 2462MHz

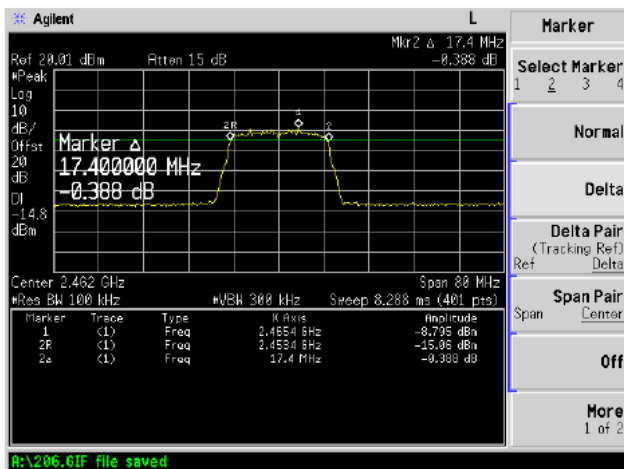

802.11 n HT40 CH7 2452MHz

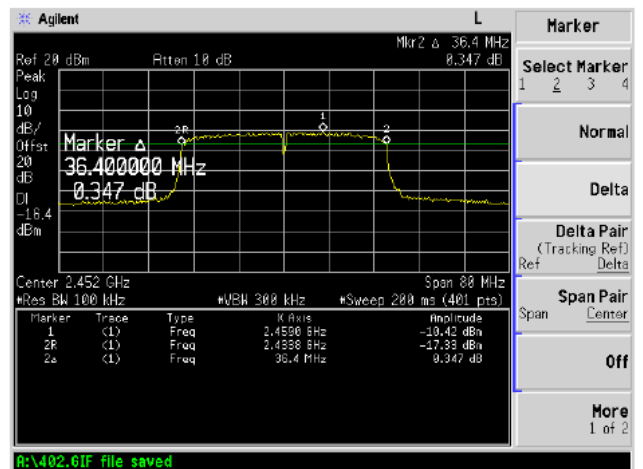

4.4. Maximum Peak Output Power

TEST CONFIGURATION

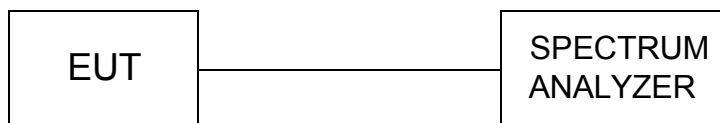

TEST PROCEDURE

According to C63.10 -2009, The EUT was directly connected to the power meter / spectrum analyzer and antenna output port as show in the block diagram as TEST CONFIGURATION shows.

1. For IEEE 802.11b/g and IEEE802.11n HT20 mode, use a PK power meter which's bandwidth is above 26dB bandwidth of signal to measure out each test modes' PK output power.
2. Spectrum analyzer only used for 802.11n HT40 measurement.

LIMIT

The Peak Output Power Measurement limits are 30dBm.

TEST RESULTS

Mode	Channel	Peak Power Output (dBm)	Peak Power Limit (dBm)	PASS / FAIL
802.11b	1	10.12	30	PASS
	6	10.45	30	PASS
	11	10.32	30	PASS
802.11g	1	10.03	30	PASS
	6	10.21	30	PASS
	11	10.15	30	PASS
802.11n HT20	1	9.54	30	PASS
	6	9.61	30	PASS
	11	9.51	30	PASS
802.11n HT40	3	8.30	30	PASS
	6	8.70	30	PASS
	9	9.26	30	PASS

Note: The test results including the cable lose.

Plots of Maximum Peak Output Power Measurement

For 802.11N Mode(40MHz):

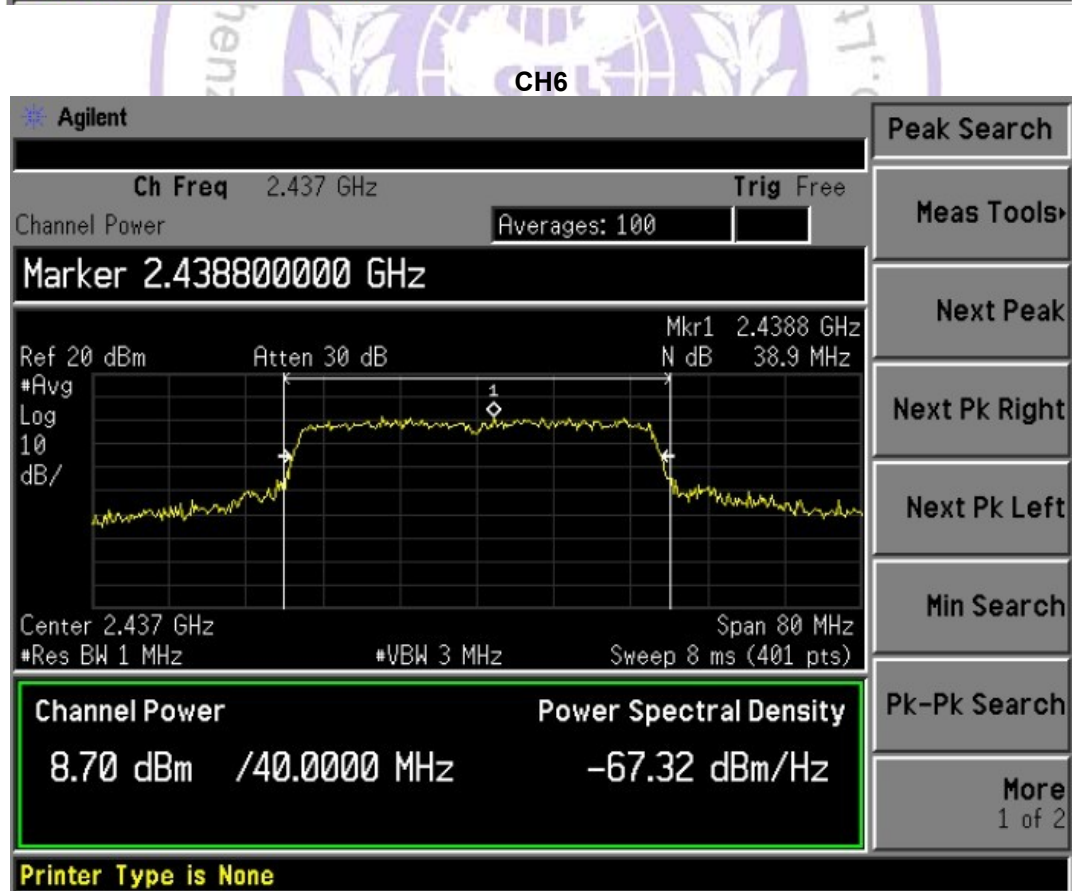
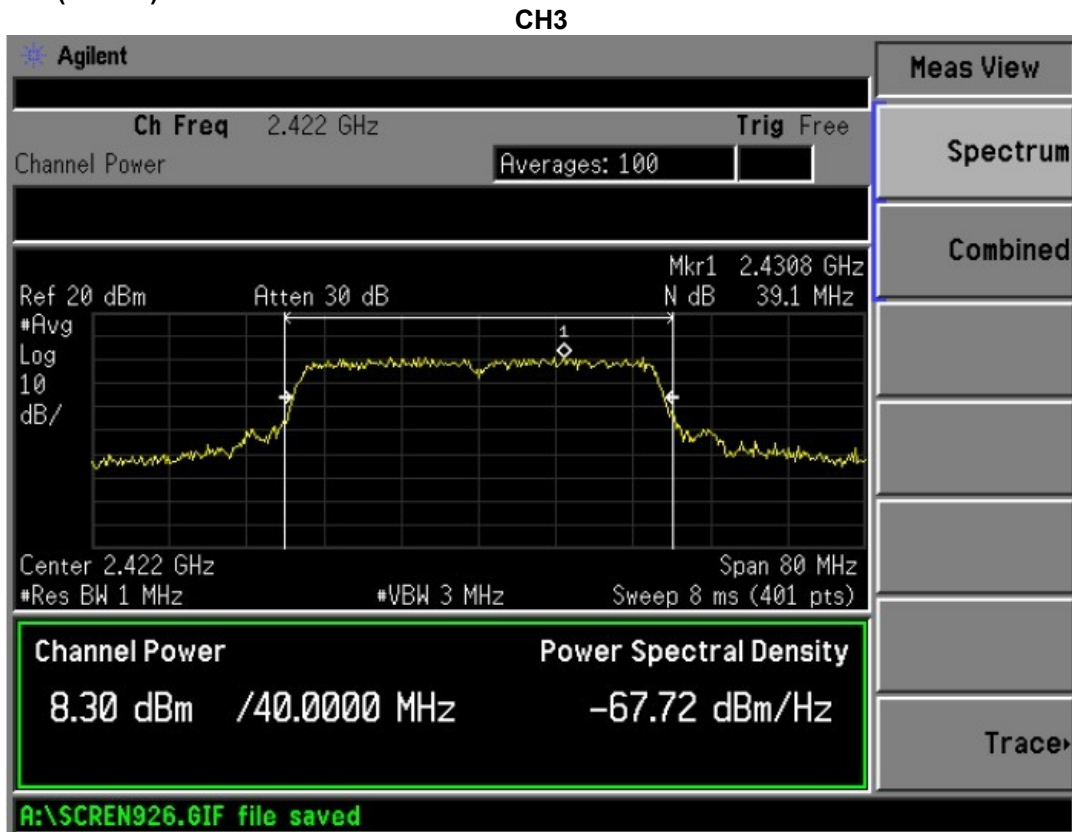

CH9

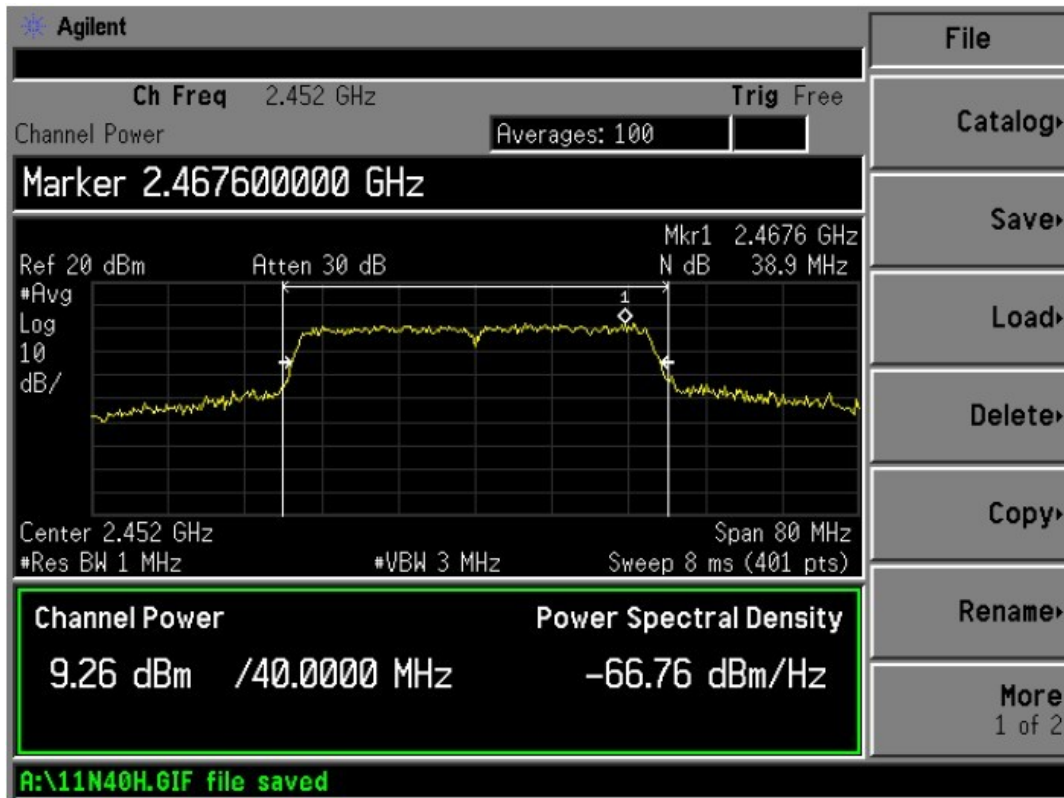

4.5. Band Edge Measurement

TEST CONFIGURATION

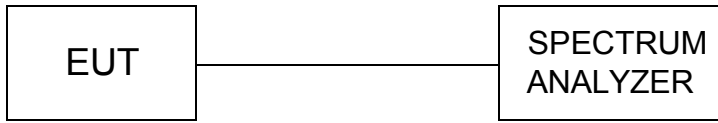

TEST PROCEDURE

The band edge compliance of RF radiated emission should be measured by following the guidance in ANSI C63.4 and FCC KDB Publication No. 558074 (Measurement Guidelines of DTS) with respect to maximizing the emission by rotating the EUT, measuring the emission while the EUT is situated in three orthogonal planes (if appropriate), adjusting the measurement antenna height and polarization etc. Set RBW=100kHz and VBM= 300kHz to measure the peak field strength and set RBW to 1MHz and VBW to 10Hz to measure the average radiated field strength.

The conducted RF band edge was measured by using a spectrum analyzer. Set span wide enough to capture the highest in-band emission and the emission at the band edge. Set RBW and VBW to 100 kHz, to measure the conducted peak band edge.

Connect the spectrum analyzer to the EUT using an appropriate RF cable connected to the EUT output. Configure the spectrum analyzer settings as described below (be sure to enter all losses between the unlicensed wireless device output and the spectrum analyzer).

- Span: Set Span for minimum 50 MHz - Reference Level: 110 dB μ V (corrected for gains and losses of test antenna factor, preamp gain and cable loss) - Attenuation: 10 dB
- Sweep Time: Coupled - Resolution Bandwidth: Up to and including 1 GHz = \geq 100 kHz
- Resolution Bandwidth: Above 1 GHz = 1 MHz - Video Bandwidth: Below 1 GHz = 300 kHz
- Video Bandwidth: Up to and including 1 GHz = \geq 3 MHz for peak and 10 Hz for average
- Detector: Peak

Place a marker at the end of the restricted band closest to the transmit frequency to show compliance. Also measure any emissions in the restricted bands. Save the spectrum analyzer plot. Repeat for each power and modulation for lowest and highest channel.

LIMIT

1. Below -20dB of the highest emission level in operating band.
2. Fall in the restricted bands listed in section 15.205. The maximum permitted average field strength is listed in section 15.209(see Section 15.205(c)).

Frequency (MHz)	Limit Average (dBuV/m)	Limit Peak (dBuV/m)
Below 2390 or Above 2483.5	54	74

TEST RESULTS

Transmitting mode: 802.11b

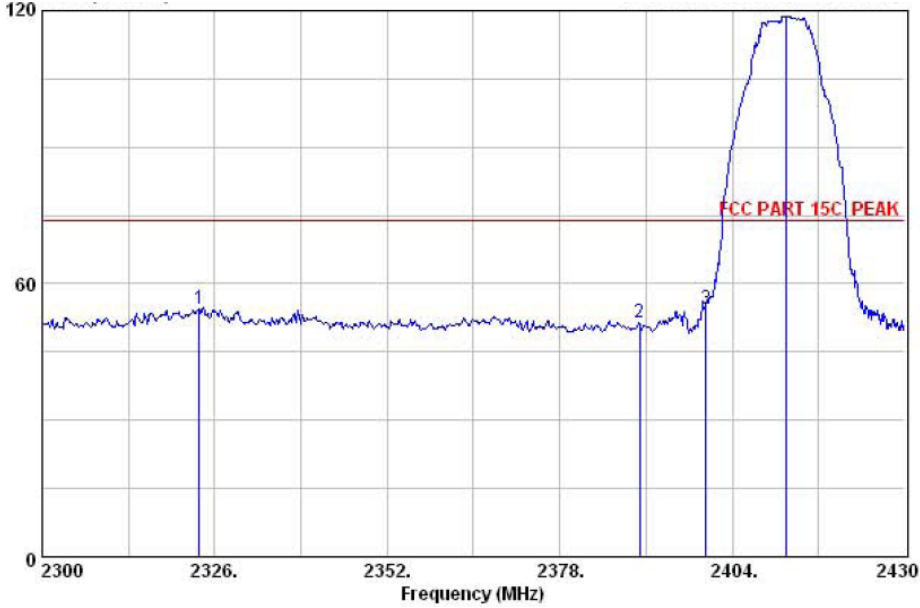

	Emission					Ant.	Cable	
	Freq. (MHz)	Level (dBuV/m)	Limits (dBuV/m)	Margin (dB)	Reading (dBuV)	Factor (dB/m)	Loss (dB)	Remark
1	2323.66	54.53	74.00	19.47	20.88	31.43	2.22	Peak
2	2390.00	51.49	74.00	22.51	17.79	31.48	2.22	Peak
3	2400.00	54.63	74.00	19.37	20.90	31.50	2.23	Peak
4	2412.06	118.70	74.00	-44.70	84.97	31.50	2.23	Peak

Note:

1. The field strength of any emissions which appear outside of this band shall not exceed the general radiated emission limits in Section 15.209, the peak radiated field strength shall blow 74dBµv/m.
2. Antenna Polarization vertical.

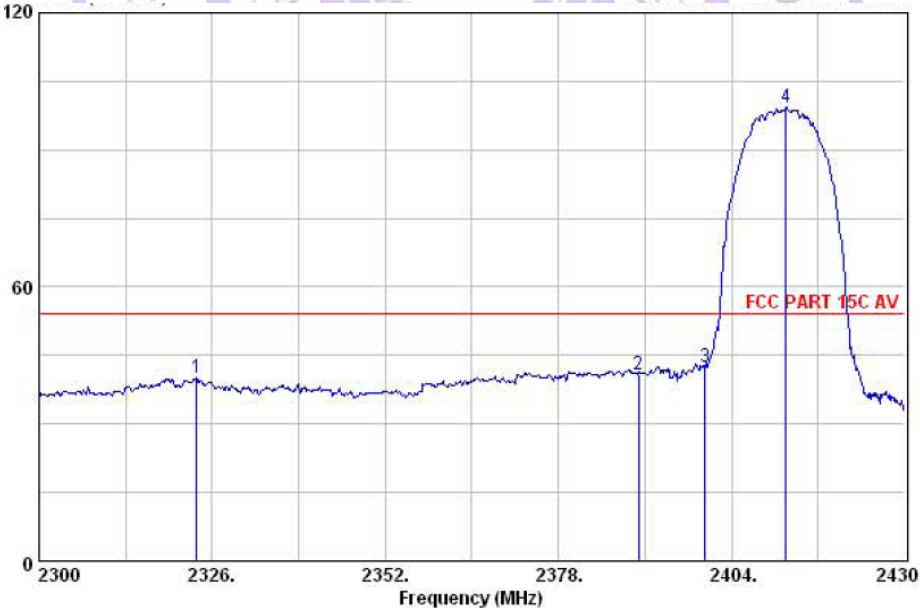

	Emission					Ant.	Cable	
	Freq. (MHz)	Level (dBuV/m)	Limits (dBuV/m)	Margin (dB)	Reading (dBuV)	Factor (dB/m)	Loss (dB)	Remark
1	2323.66	39.99	54.00	14.01	6.34	31.43	2.22	Average
2	2390.00	40.89	54.00	13.11	7.19	31.48	2.22	Average
3	2400.00	42.42	54.00	11.58	8.69	31.50	2.23	Average
4	2412.19	99.42	54.00	-45.42	65.69	31.50	2.23	Average

Note:

1. The field strength of any emissions which appear outside of this band shall not exceed the general radiated emission limits in Section 15.209, the average radiated field strength shall blow 54dBµv/m.
2. Antenna Polarization vertical.

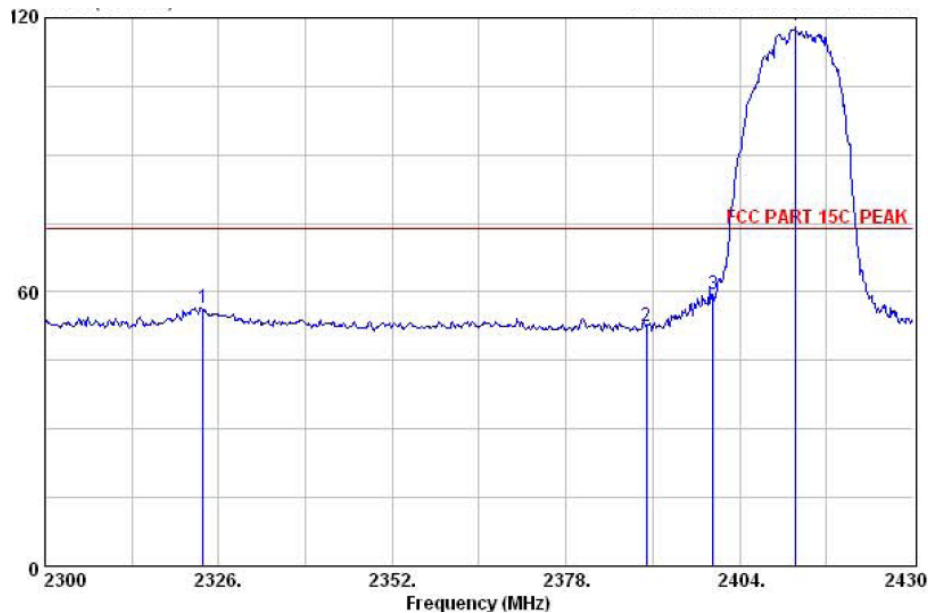

Emission					Ant.	Cable		
Freq. (MHz)	Level (dBuV/m)	Limits (dBuV/m)	Margin (dB)	Reading (dBuV)	Factor (dB/m)	Loss (dB)	Remark	
1 2323.66	56.62	74.00	17.38	22.97	31.43	2.22	Peak	
2 2390.00	52.38	74.00	21.62	18.68	31.48	2.22	Peak	
3 2400.00	59.42	74.00	14.58	25.69	31.50	2.23	Peak	
4 2412.32	118.34	74.00	-44.34	84.61	31.50	2.23	Peak	

Note:

1. The field strength of any emissions which appear outside of this band shall not exceed the general radiated emission limits in Section 15.209, the peak radiated field strength shall blow 74dB μ v/m.
2. Antenna Polarization horizontal.

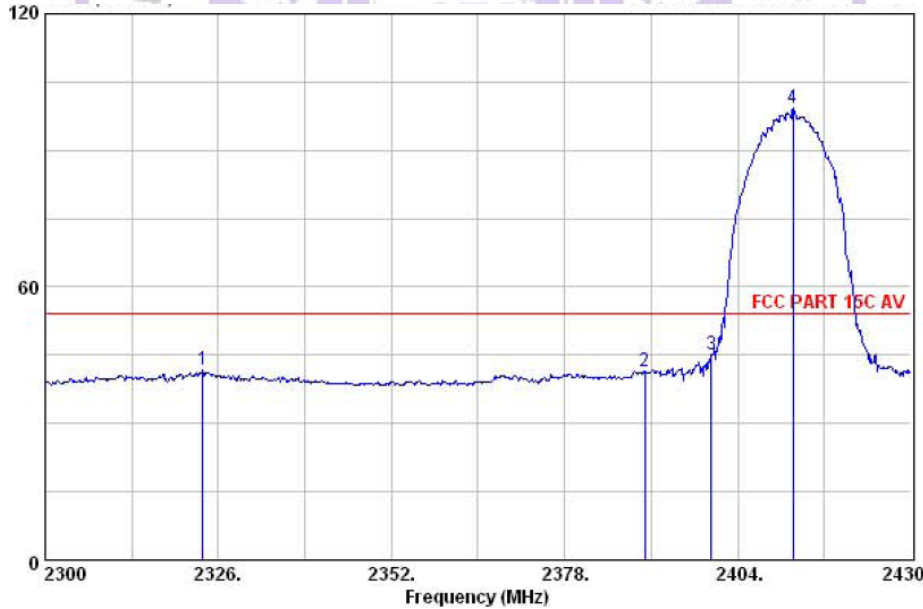

Emission					Ant.	Cable		
Freq. (MHz)	Level (dBuV/m)	Limits (dBuV/m)	Margin (dB)	Reading (dBuV)	Factor (dB/m)	Loss (dB)	Remark	
1 2323.66	41.63	54.00	12.37	7.98	31.43	2.22	Average	
2 2390.00	41.45	54.00	12.55	7.75	31.48	2.22	Average	
3 2400.00	45.17	54.00	8.83	11.44	31.50	2.23	Average	
4 2412.32	99.16	54.00	-45.16	65.43	31.50	2.23	Average	

Note:

1. The field strength of any emissions which appear outside of this band shall not exceed the general radiated emission limits in Section 15.209, the average radiated field strength shall blow 54dB μ v/m.
2. Antenna Polarization horizontal.

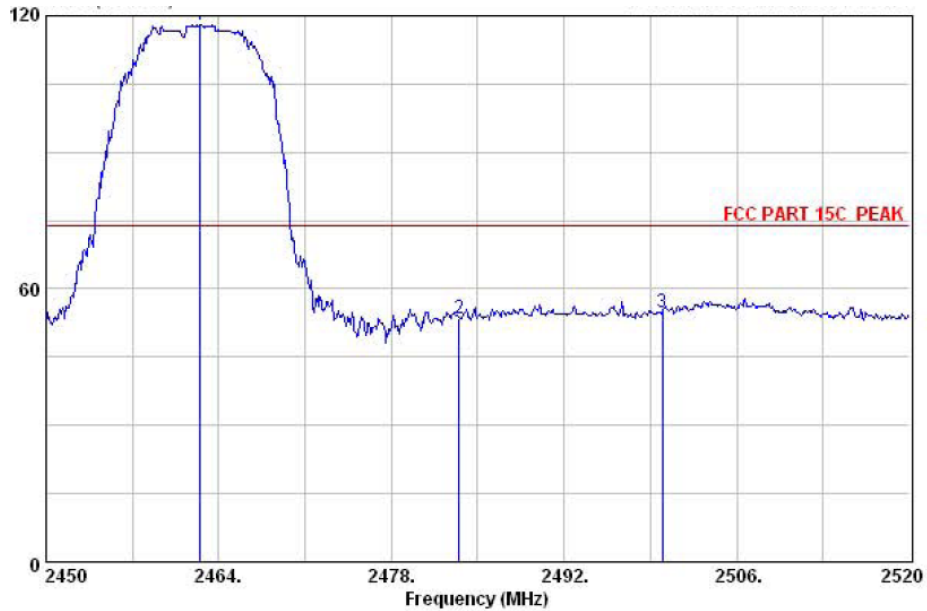

	Emission		Limits		Margin	Reading	Ant.	Cable	Remark
	Freq. (MHz)	Level (dBuV/m)	(dBuV/m)	(dBuV/m)	(dB)	(dBuV)	Factor (dB/m)	Loss (dB)	
1	2462.53	117.95	74.00	-43.95	84.16	31.56	2.23	Peak	
2	2483.50	53.49	74.00	20.51	19.68	31.58	2.23	Peak	
3	2500.00	54.92	74.00	19.08	21.09	31.60	2.23	Peak	

Note:

1. The field strength of any emissions which appear outside of this band shall not exceed the general radiated emission limits in Section 15.209, the peak radiated field strength shall blow 74dB μ v/m.
2. Antenna Polarization horizontal.

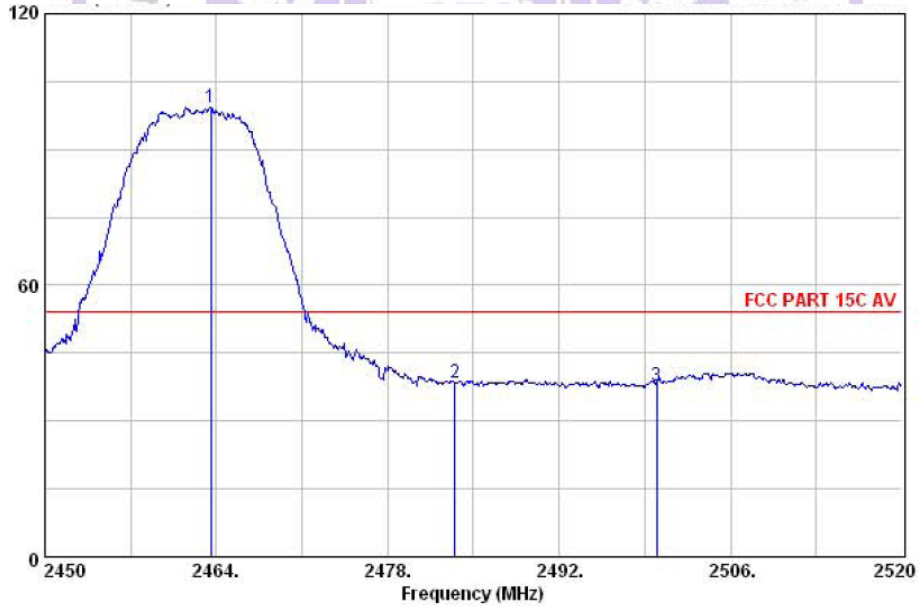

	Emission		Limits		Margin	Reading	Ant.	Cable	Remark
	Freq. (MHz)	Level (dBuV/m)	(dBuV/m)	(dBuV/m)	(dB)	(dBuV)	Factor (dB/m)	Loss (dB)	
1	2463.58	99.34	54.00	-45.34	65.55	31.56	2.23	Average	
2	2483.50	38.36	54.00	15.64	4.55	31.58	2.23	Average	
3	2500.00	37.91	54.00	16.09	4.08	31.60	2.23	Average	

Note:

1. The field strength of any emissions which appear outside of this band shall not exceed the general radiated emission limits in Section 15.209, the average radiated field strength shall blow 54dB μ v/m.
2. Antenna Polarization horizontal.

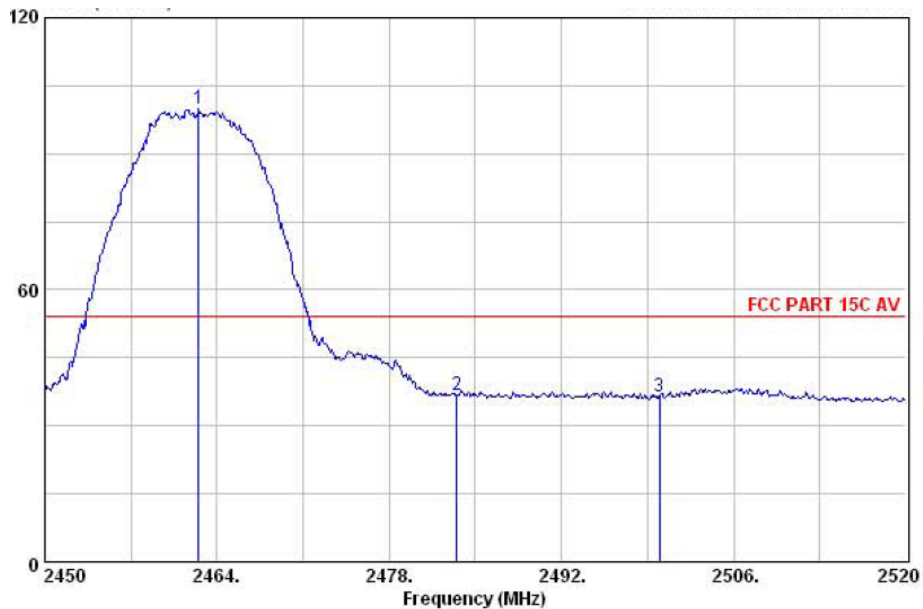

	Emission				Ant.	Cable	
Freq.	Level	Limits	Margin	Reading	Factor	Loss	Remark
(MHz)	(dBUV/m)	(dBUV/m)	(dB)	(dBUV)	(dB/m)	(dB)	
1 2462.53	99.92	54.00	-45.92	66.13	31.56	2.23	Average
2 2483.50	36.88	54.00	17.12	3.07	31.58	2.23	Average
3 2500.00	36.48	54.00	17.52	2.65	31.60	2.23	Average

Note:

1. The field strength of any emissions which appear outside of this band shall not exceed the general radiated emission limits in Section 15.209, the peak radiated field strength shall blow 74dB μ v/m.
2. Antenna Polarization vertical.

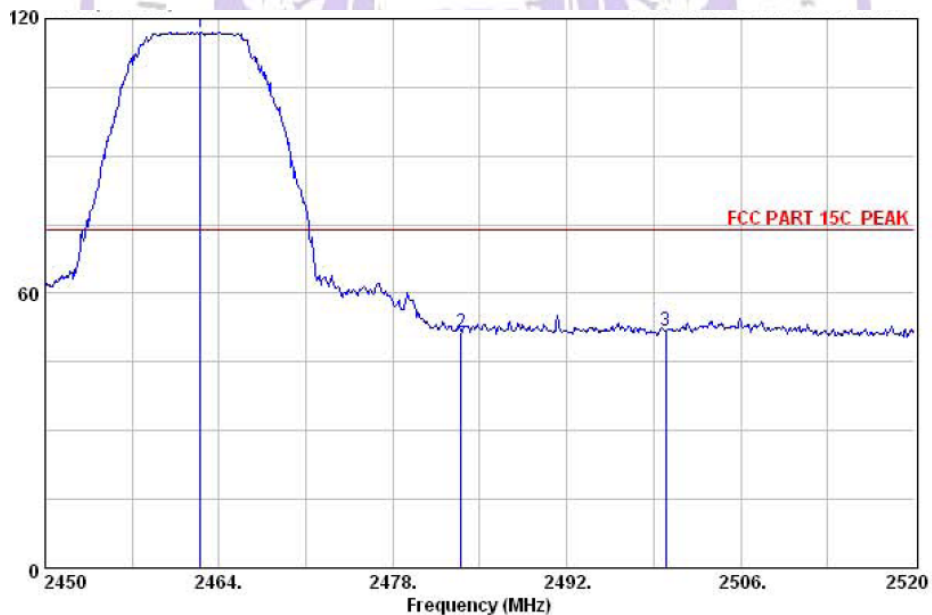

	Emission				Ant.	Cable	
Freq.	Level	Limits	Margin	Reading	Factor	Loss	Remark
(MHz)	(dBUV/m)	(dBUV/m)	(dB)	(dBUV)	(dB/m)	(dB)	
1 2462.53	117.01	74.00	-43.01	83.22	31.56	2.23	Peak
2 2483.50	51.35	74.00	22.65	17.54	31.58	2.23	Peak
3 2500.00	51.79	74.00	22.21	17.96	31.60	2.23	Peak

Note:

1. The field strength of any emissions which appear outside of this band shall not exceed the general radiated emission limits in Section 15.209, the average radiated field strength shall blow 54dB μ v/m.
2. Antenna Polarization vertical.

Note : For 802.11g Mode:

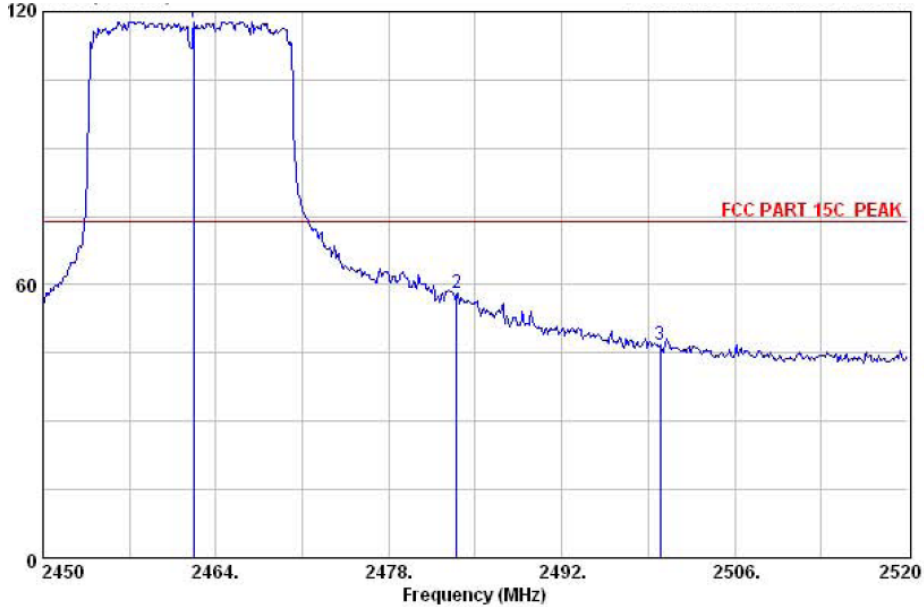

	Emission		Margin		Ant. Cable		Remark
Freq. (MHz)	Level (dBuV/m)	Limits (dBuV/m)	(dB)	Reading (dBuV)	Factor (dB/m)	Loss (dB)	
1 2462.18	117.78	74.00	-43.78	83.99	31.56	2.23	Peak
2 2483.50	58.28	74.00	15.72	24.47	31.58	2.23	Peak
3 2500.00	46.71	74.00	27.29	12.88	31.60	2.23	Peak

Note:

1. The field strength of any emissions which appear outside of this band shall not exceed the general radiated emission limits in Section 15.209, the peak radiated field strength shall blow 74dBµv/m.
2. Antenna Polarization vertical.

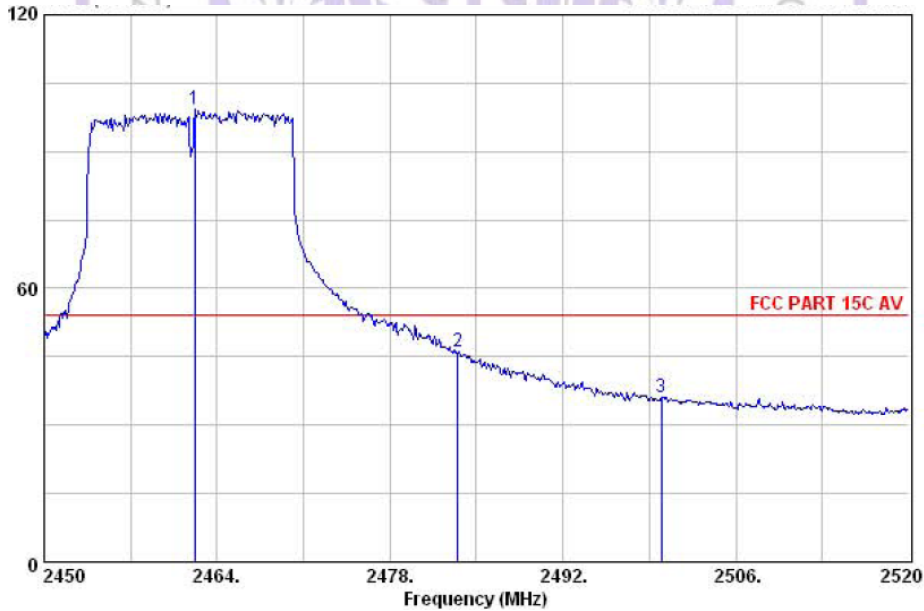

	Emission		Margin		Ant. Cable		Remark
Freq. (MHz)	Level (dBuV/m)	Limits (dBuV/m)	(dB)	Reading (dBuV)	Factor (dB/m)	Loss (dB)	
1 2462.18	99.28	54.00	-45.28	65.49	31.56	2.23	Average
2 2483.50	46.01	54.00	7.99	12.20	31.58	2.23	Average
3 2500.00	36.25	54.00	17.75	2.42	31.60	2.23	Average

Note:

1. The field strength of any emissions which appear outside of this band shall not exceed the general radiated emission limits in Section 15.209, the average radiated field strength shall blow 54dBµv/m.
2. Antenna Polarization vertical.

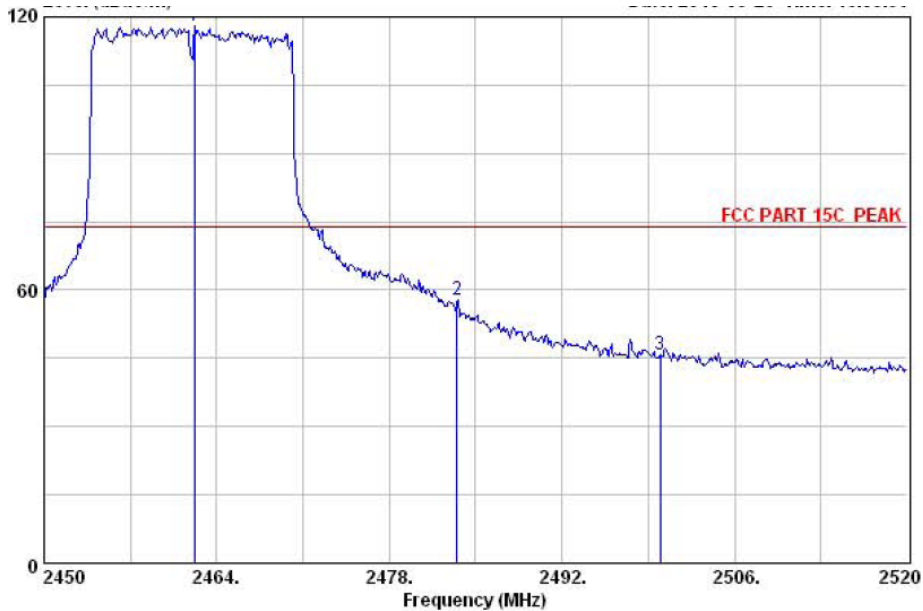

	Emission					Ant.	Cable	
	Freq. (MHz)	Level (dBuV/m)	Limits (dBuV/m)	Margin (dB)	Reading (dBuV)	Factor (dB/m)	Loss (dB)	Remark
1	2462.18	117.98	74.00	-43.98	84.19	31.56	2.23	Peak
2	2483.50	57.76	74.00	16.24	23.95	31.58	2.23	Peak
3	2500.00	45.83	74.00	28.17	12.00	31.60	2.23	Peak

Note:

1. The field strength of any emissions which appear outside of this band shall not exceed the general radiated emission limits in Section 15.209, the peak radiated field strength shall blow 74dBµv/m.
2. Antenna Polarization horizontal.

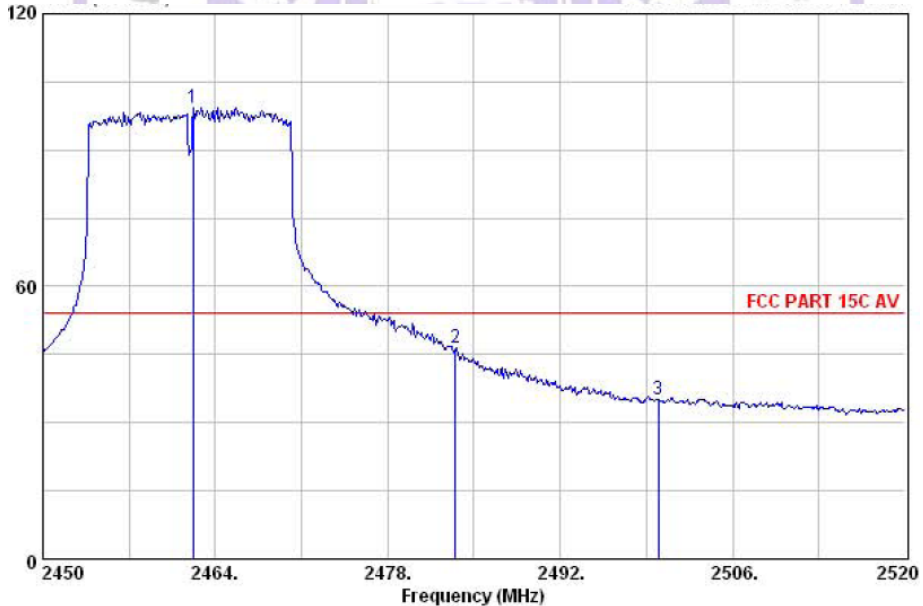

	Emission					Ant.	Cable	
	Freq. (MHz)	Level (dBuV/m)	Limits (dBuV/m)	Margin (dB)	Reading (dBuV)	Factor (dB/m)	Loss (dB)	Remark
1	2462.18	99.32	54.00	-45.32	65.53	31.56	2.23	Average
2	2483.50	46.58	54.00	7.42	12.77	31.58	2.23	Average
3	2500.00	35.07	54.00	18.93	1.24	31.60	2.23	Average

Note:

1. The field strength of any emissions which appear outside of this band shall not exceed the general radiated emission limits in Section 15.209, the average radiated field strength shall blow 54dBµv/m.
2. Antenna Polarization horizontal.

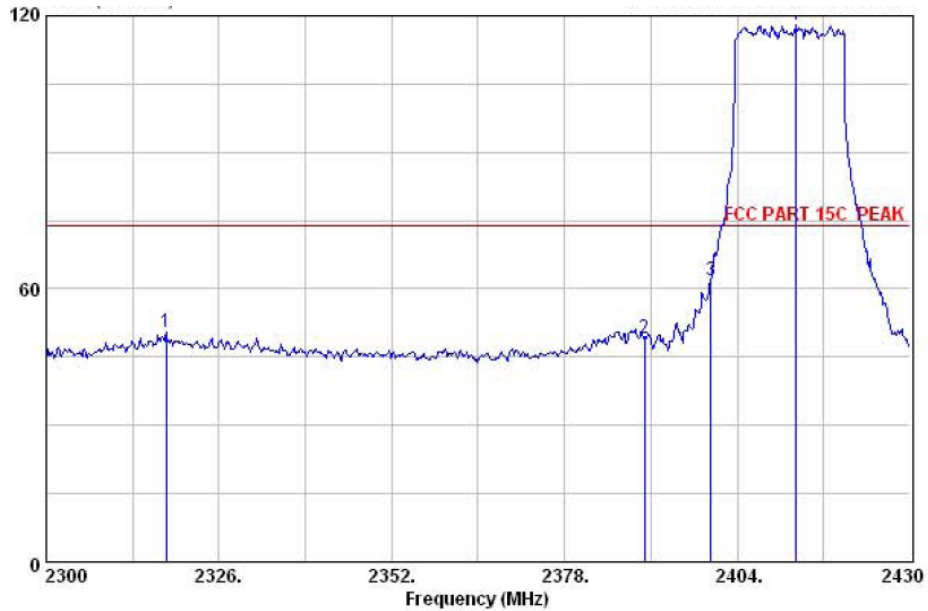

	Emission					Ant.	Cable	
	Freq.	Level	Limits	Margin	Reading	Factor	Loss	Remark
	(MHz)	(dBuV/m)	(dBuV/m)	(dB)	(dBuV)	(dB/m)	(dB)	
1	2318.07	50.38	74.00	23.62	16.75	31.41	2.22	Peak
2	2390.00	49.08	74.00	24.92	15.38	31.48	2.22	Peak
3	2400.00	61.72	74.00	12.28	27.99	31.50	2.23	Peak
4	2412.71	117.85	74.00	-43.85	84.12	31.50	2.23	Peak

Note:

1. The field strength of any emissions which appear outside of this band shall not exceed the general radiated emission limits in Section 15.209, the peak radiated field strength shall blow 74dB μ v/m.
2. Antenna Polarization horizontal.

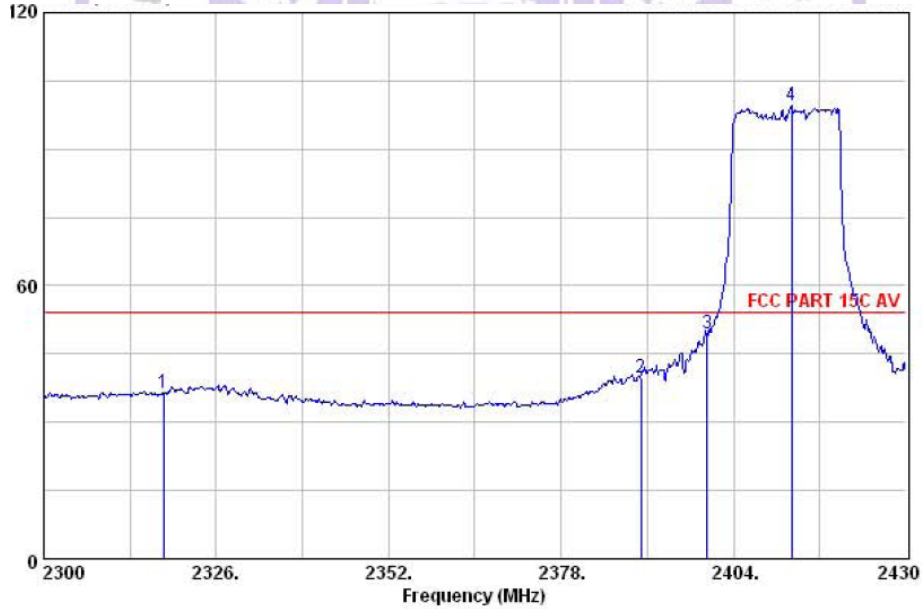

	Emission					Ant.	Cable	
	Freq.	Level	Limits	Margin	Reading	Factor	Loss	Remark
	(MHz)	(dBuV/m)	(dBuV/m)	(dB)	(dBuV)	(dB/m)	(dB)	
1	2318.07	36.39	54.00	17.61	2.76	31.41	2.22	Average
2	2390.00	39.81	54.00	14.19	6.11	31.48	2.22	Average
3	2400.00	49.62	54.00	4.38	15.89	31.50	2.23	Average
4	2412.71	99.59	54.00	-45.59	65.86	31.50	2.23	Average

Note:

1. The field strength of any emissions which appear outside of this band shall not exceed the general radiated emission limits in Section 15.209, the average radiated field strength shall blow 54dB μ v/m.
2. Antenna Polarization horizontal.

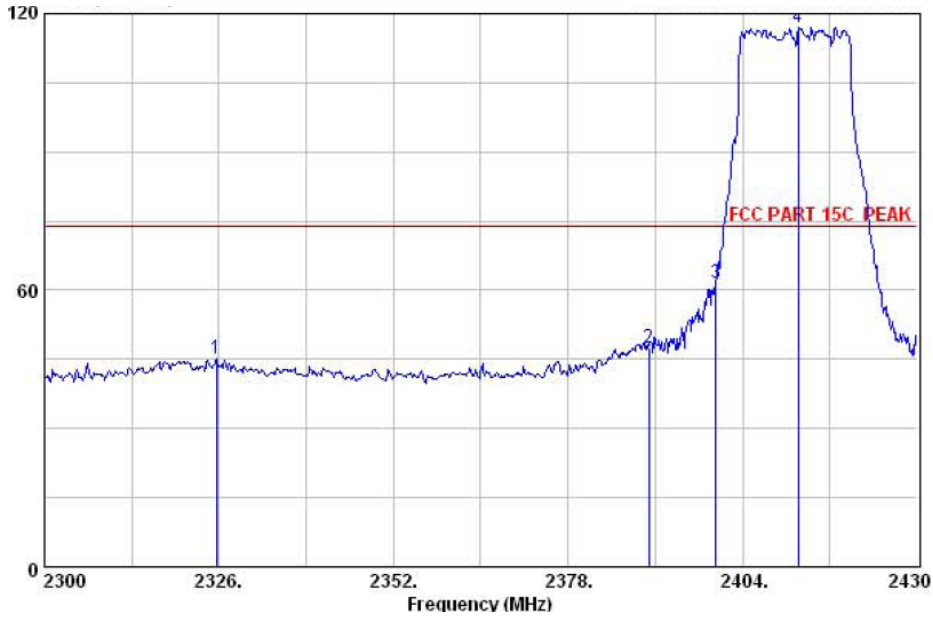

	Emission					Ant.	Cable	
	Freq.	Level	Limits	Margin	Reading	Factor	Loss	Remark
	(MHz)	(dBuV/m)	(dBuV/m)	(dB)	(dBuV)	(dB/m)	(dB)	
1	2325.61	45.25	74.00	28.75	11.60	31.43	2.22	Peak
2	2390.00	47.54	74.00	26.46	13.84	31.48	2.22	Peak
3	2400.00	61.48	74.00	12.52	27.75	31.50	2.23	Peak
4	2412.32	117.06	74.00	-43.06	83.33	31.50	2.23	Peak

Note:

1. The field strength of any emissions which appear outside of this band shall not exceed the general radiated emission limits in Section 15.209, the peak radiated field strength shall blow 74dBµv/m.
2. Antenna Polarization vertical.

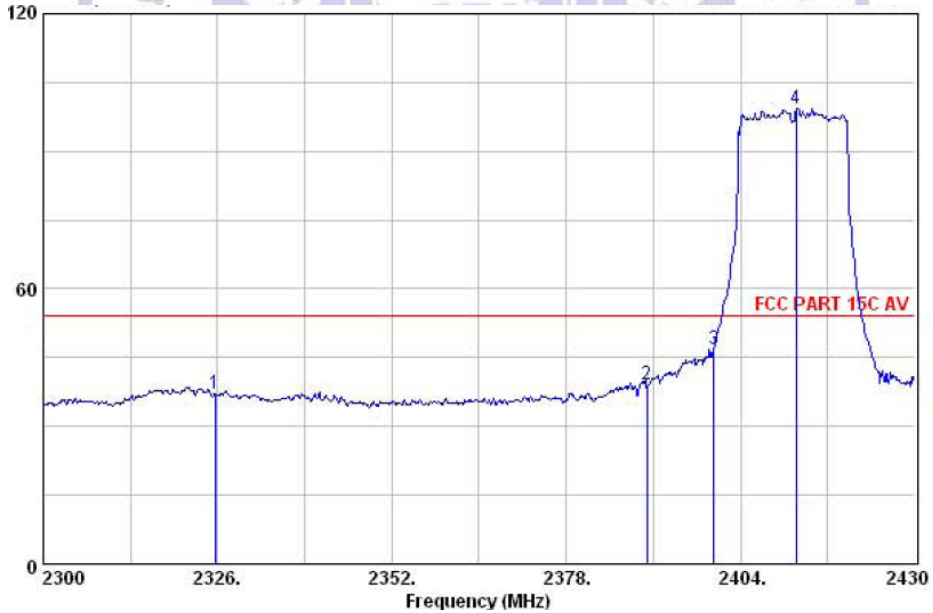

	Emission					Ant.	Cable	
	Freq.	Level	Limits	Margin	Reading	Factor	Loss	Remark
	(MHz)	(dBuV/m)	(dBuV/m)	(dB)	(dBuV)	(dB/m)	(dB)	
1	2325.61	37.25	54.00	16.75	3.60	31.43	2.22	Average
2	2390.00	39.21	54.00	14.79	5.51	31.48	2.22	Average
3	2400.00	46.83	54.00	7.17	13.10	31.50	2.23	Average
4	2412.32	99.36	54.00	-45.36	65.63	31.50	2.23	Average

Note:

1. The field strength of any emissions which appear outside of this band shall not exceed the general radiated emission limits in Section 15.209, the average radiated field strength shall blow 54dBµv/m.
2. Antenna Polarization vertical.