



Shenzhen CTL Electromagnetic Technology Co., Ltd.
Tel: +86-755-89486194 Fax: +86-755-89486187

FCC PART 15 SUBPART C TEST REPORT

FCC Part 15.247

Report Reference No......: **CTL11038096-S-WF**

Compiled by

(position+printed name+signature)..: File administrators Andy Zhang

Andy Zhang

Name of the organization performing the tests

Test Engineer Kendy Wang

Kendy Wang

(position+printed name+signature)..:

Approved by

(position+printed name+signature)..: Manager Tracy Qi

Tracy Qi

Date of issue.....: March 11, 2011

Representative Laboratory Name : **Shenzhen CTL Electromagnetic Technology Co., Ltd.**

Address: Zone B, 4/F, Block 20, Guangqian Industrial Park, Longzhu Road, Nanshan, Shenzhen 518055 China.

Test Firm: **Bontek Compliance Testing Laboratory Ltd**

Address: 1/F, Block East H-3, OCT Eastern Ind. Zone, Qiaocheng East Road, Nanshan, Shenzhen, China

Applicant's name.....: **SHENZHEN MTN ELECTRONICS CO.,LTD.**

Address: MTN Industrial Park, No. 3 Fuhua Road, Pingxi Neighborhood, Pingdi Town , Longgang District, Shenzhen

Test specification:

Standard: FCC Part 15.247: Operation within the bands 902–928 MHz, 2400–2483.5 MHz, and 5725–5850 MHz.

TRF Originator.....: Shenzhen CTL Electromagnetic Technology Co., Ltd.

Master TRF.....: Dated 2011-01

Shenzhen CTL Electromagnetic Technology Co., Ltd. All rights reserved.

This publication may be reproduced in whole or in part for non-commercial purposes as long as the Shenzhen CTL Electromagnetic Technology Co., Ltd. is acknowledged as copyright owner and source of the material. Shenzhen CTL Electromagnetic Technology Co., Ltd. takes no responsibility for and will not assume liability for damages resulting from the reader's interpretation of the reproduced material due to its placement and context.

Test item description: **Wireless Router**

FCC ID.....: **ZBXWR-150**

Trade Mark: /

Model/Type reference: WR-150

Listed Models: /

Modulation: DSSS, OFDM

Work Frequency Range.....: 2412~2462MHz

Antenna Type.....: Undetachable

Result: **Positive**

TEST REPORT

Test Report No. : CTL11038096-S-WF	Oct 18, 2010
	Date of issue

Equipment under Test : Wireless Router

Model /Type : WR-150

Listed Models : /

Applicant : SHENZHEN MTN ELECTRONICS CO.,LTD.

Address : MTN Industrial Park, No. 3 Fuhua Road, Pingxi Neighborhood, Pingdi Town , Longgang District, Shenzhen

Manufacturer : SHENZHEN MTN ELECTRONICS CO.,LTD.

Address : MTN Industrial Park, No. 3 Fuhua Road, Pingxi Neighborhood, Pingdi Town , Longgang District, Shenzhen

Test Result according to the standards on page 4:	Positive
--	-----------------

The test report merely corresponds to the test sample.
It is not permitted to copy extracts of these test result without the written permission of the test laboratory.

Contents

1.	<u>TEST STANDARDS</u>	<u>3</u>
2.	<u>SUMMARY</u>	<u>3</u>
2.1.	General Remarks	3
2.2.	Equipment Under Test	3
2.3.	Short description of the Equipment under Test (EUT)	3
2.4.	EUT operation mode	3
2.5.	EUT configuration	3
2.6.	NOTE	3
2.7.	Related Submittal(s) / Grant (s)	3
2.8.	Modifications	3
3.	<u>TEST ENVIRONMENT</u>	<u>3</u>
3.1.	Address of the test laboratory	3
3.2.	Test Facility	3
3.3.	Environmental conditions	3
3.4.	Configuration of Tested System	3
3.5.	Statement of the measurement uncertainty	3
3.6.	Equipments Used during the Test	3
3.7.	Summary of Test Result	3
4.	<u>TEST CONDITIONS AND RESULTS</u>	<u>3</u>
4.1.	Conducted Emissions Test	3
4.2.	Radiated Emission Test	3
4.3.	6dB Bandwidth Measurement	3
4.4.	Maximum Peak Output Power	3
4.5.	Band Edge Measurement	3
4.6.	Power Spectral Density Measurement	3
4.7.	Spurious RF Conducted Emission	3
4.8.	Antenna Requirement	3
5.	<u>TEST SETUP PHOTOS OF THE EUT</u>	<u>3</u>
6.	<u>EXTERNAL AND INTERNAL PHOTOS OF THE EUT</u>	<u>3</u>

1. TEST STANDARDS

The tests were performed according to following standards:

[FCC Part 15.247](#): Frequency Hopping, Direct Spread Spectrum and Hybrid Systems that are in operation within the bands of 902-928 MHz, 2400-2483.5 MHz, and 5725-5850 MHz.

[ANSI C63.4-2003](#)

[KDB Publication No. 558074 Guidance on Measurements for Digital Transmission Systems](#)

[ANSI C63.10-2009](#): American National Standard for Testing Unlicensed Wireless Devices.



2. SUMMARY

2.1. General Remarks

Date of receipt of test sample : March 2, 2011

Testing commenced on : March 3, 2011

Testing concluded on : March 8, 2011

2.2. Equipment Under Test

Power supply system utilised

Power supply voltage : 120V / 60 Hz 115V / 60Hz
 12 V DC 24 V DC
 Other (specified in blank below)

DC 9V from adapter

Description of the test mode

IEEE 802.11b/g/n: Thirteen channels are provided to the EUT, but only eleventh channels used for USA.

Channel	Frequency(MHz)	Channel	Frequency(MHz)
1	2412	8	2447
2	2417	9	2452
3	2422	10	2457
4	2427	11	2462
5	2432		
6	2437		
7	2442		

2.3. Short description of the Equipment under Test (EUT)

2.4GHz (Wireless Lite N ADSL2+ Modem Router)

For more details, refer to the user's manual of the EUT.

Serial number: Prototype

2.4. EUT operation mode

Test Mode:

1. The EUT has been tested under normal operating condition.
2. Test program used to control the EUT for staying in continuous transmitting and receiving mode is programmed. Channel low (2412MHz), mid (2442MHz) and high (2462MHz) with highest data rate are chosen for full testing.

2.5. EUT configuration

The following peripheral devices and interface cables were connected during the measurement:

- - supplied by the manufacturer

- - supplied by the lab

- Power Cable Length (m) : /

Shield : /

Detachable : /

- Multimeter Manufacturer : /

Model No. : /

- AC Adapter

MODEL: GP301E-090-080

INPUT: 100-240V~50/60Hz 0.3A

OUTPUT: 9.0V $\overline{\overline{=}}$ 0.8A

Power Cable: 150cm

◇ Shield ◆ Unshield

2.6. NOTE

1. The EUT is an 802.11b/g/n Home Gateway, The functions of the EUT listed as below:

	Test Standards	Reference Report
WLAN 802.11b/g, 802.11n	FCC Part 15 Subpart C (Section15.247)	CTL11038096-S-WF
WLAN 802.11b/g, 802.11n	FCC Per 47 CFR 2.1091(b)	CTL11038096-S-WM

2. The frequency bands used in this EUT are listed as follows:

Frequency Band(MHz)	2400-2483.5	5150-5350	5470-5725	5725-5850
802.11b	√	—	—	—
802.11g	√	—	—	—
802.11n(20MHz)	√	—	—	—
802.11n(40MHz)	√	—	—	—

3. The EUT incorporates a MIMO function, Physically, the EUT provides two completed transmitter and two completed receivers.

Modulation Mode	TX Function
802.11b	1TX
802.11g	1TX
802.11n (20MHz)	2TX
802.11n (40MHz)	2TX

2.7. Related Submittal(s) / Grant (s)

This submittal(s) (test report) is intended for FCC ID: **ZBXWR-150** filing to comply with of the FCC Part 15.247 Rules.

2.8. Modifications

No modifications were implemented to meet testing criteria.

3. TEST ENVIRONMENT

3.1. Address of the test laboratory

Bontek Compliance Testing Laboratory Ltd
 1/F, Block East H-3, OCT Eastern Ind. Zone, Qiaocheng East Road, Nanshan, Shenzhen, China

The sites are constructed in conformance with the requirements of ANSI C63.7, ANSI C63.4 (2003) and CISPR Publication 22.

3.2. Test Facility

The test facility is recognized, certified, or accredited by the following organizations:

IC Registration No.: 7631A

The 3m alternate test site of Bontek Compliance Testing Laboratory Ltd EMC Laboratory has been registered by Certification and Engineer Bureau of Industry Canada for the performance of with Registration NO.: 7631A on March, 2008.

FCC-Registration No.: 338263

Bontek Compliance Testing Laboratory Ltd EMC Laboratory has been registered and fully described in a report filed with the (FCC) Federal Communications Commission. The acceptance letter from the FCC is maintained in our files. Registration 338263, March 24, 2008.

3.3. Environmental conditions

During the measurement the environmental conditions were within the listed ranges:

- Temperature: 15-35 ° C
- Humidity: 30-60 %
- Atmospheric pressure: 950-1050mbar

3.4. Configuration of Tested System

Fig. 2-1 Configuration of Tested System

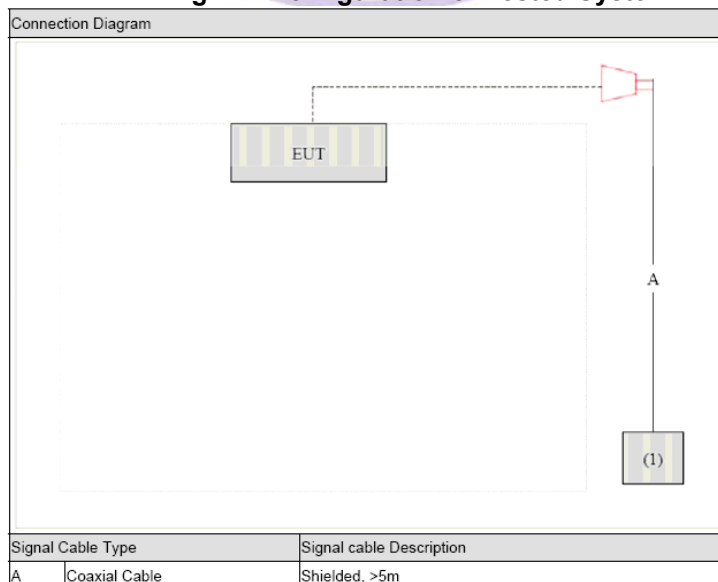

3.5. Statement of the measurement uncertainty

The data and results referenced in this document are true and accurate. The reader is cautioned that there may be errors within the calibration limits of the equipment and facilities. The measurement uncertainty was calculated for all measurements listed in this test report acc. to CISPR 16 - 4 „Specification for radio disturbance and immunity measuring apparatus and methods – Part 4: Uncertainty in EMC Measurements“ and is documented in the Bontek Compliance Testing Laboratory Ltd quality system acc. to DIN EN ISO/IEC 17025. Furthermore, component and process variability of devices similar to that tested may result in additional deviation. The manufacturer has the sole responsibility of continued compliance of the device.

Hereafter the best measurement capability for Bontek laboratory is reported:

Test	Range	Measurement Uncertainty	Notes
Radiated Emission	30~1000MHz	4.10dB	(1)
Radiated Emission	1~12.75GHz	4.32dB	(1)
Conducted Disturbance	0.15~30MHz	3.20dB	(1)

- (1) This uncertainty represents an expanded uncertainty expressed at approximately the 95% confidence level using a coverage factor of k=2.

3.6. Equipments Used during the Test

Item	Test Equipment	Manufacturer	Model No.	Last Cal.	Due. Date
1	EMI Test Receiver	ROHDE & SCHWARZ	ESCI	2010/04/15	2011/04/14
2	Radio Communication Tester	ROHDE & SCHWARZ	CMU200	2010/04/15	2011/04/14
3	Dual Directional Coupler	Agilent	778D	2010/04/15	2011/04/14
4	10dB attenuator	SCHWARZBECK	MTAIMP-136	2010/04/15	2011/04/14
5	Tunable Bandreject filter	K&L	3TNF-800	2010/04/15	2011/04/14
6	Tunable Bandreject filter	K&L	5TNF-1700	2010/04/15	2011/04/14
7	High-Pass Filter	K&L	9SH10-2700/X12750-O/O	2010/04/15	2011/04/14
8	High-Pass Filter	K&L	41H10-1375/U12750-O/O	2010/04/15	2011/04/14
9	Coaxial Cable	Huber+Suhner	AC4-RF-H	2010/04/15	2011/04/14
10	AC Power Supply	IDRC	CF-500TP	2010/04/15	2011/04/14
11	DC Power Supply	IDRC	CD-035-020PR	2010/04/15	2011/04/14
12	RF Current Probe	FCC	F-33-4	2010/04/15	2011/04/14
13	Temperature /Humidity Meter	zhicheng	ZC1-2	2010/04/15	2011/04/14
14	MICROWAVE AMPLIFIER	HP	8349B	2010/04/15	2011/04/14
15	Amplifier	HP	8447D	2010/04/15	2011/04/14
16	SIGNAL GENERATOR	HP	8647A	2010/04/15	2011/04/14
17	Log Periodic Antenna	ELECTRO-METRICS	EM-6950	2010/04/15	2011/04/14
18	Horn Antenna	Schwarzbeck	BBHA9120A	2010/04/15	2011/04/14
19	EMI Test Receiver	R&S	ESPI	2010/04/15	2011/04/14

3.7. Summary of Test Result

FCC PART 15		
FCC Part 15.207	AC Power Conducted Emission	PASS
FCC Part 15.247(a)(2)	6dB Bandwidth	PASS
FCC Part 15.247(d)	Spurious RF Conducted Emission	PASS
FCC Part 15.247(b)	Maximum Peak Output Power	PASS
FCC Part 15.247(e)	Power Spectral Density	PASS
FCC Part 15.109/ 15.205/ 15.209	Radiated Emissions	PASS
FCC Part 15.247(d)	Band Edge Compliance of RF Emission	PASS
FCC Part 15.203/15.247 (b)	Antenna Requirement	PASS
FCC Per 47 CFR 2.1091(b)	MPE Evaluation	PASS

Remark: The measurement uncertainty is not included in the test result.

Preliminary tests were performed in different data rate to find the worst radiated emission. The data rate shown in the table below is the worst-case rate with respect to the specific test item. Investigation has been done on all the possible configurations for searching the worst cases. The following table is a list of the test modes shown in this test report.

Test Items	Mode	Data Rate	Channel
AC Power Conducted Emission	Normal Link	11 Mbps	1
Maximum Peak Conducted Output Power Power Spectral Density 6dB Bandwidth Spurious RF conducted emission	11b/DSSS	11 Mbps	1/6/11
	11g/OFDM	54 Mbps	1/6/11
	11n(20MHz)/OFDM	65Mbps	1/6/11
	11n(40MHz)/OFDM	135Mbps	3/6/9
Radiated Emission 30MHz~1GHz	11b/DSSS	11 Mbps	1/6/11
	11g/OFDM	54 Mbps	1/6/11
	11n(20MHz)/OFDM	65Mbps	1/6/11
	11n(40MHz)/OFDM	135Mbps	3/6/9
Radiated Emission 1GHz~10th Harmonic	11b/DSSS	11 Mbps	1/6/11
	11g/OFDM	54 Mbps	1/6/11
	11n(20MHz)/OFDM	65Mbps	1/6/11
	11n(40MHz)/OFDM	135Mbps	3/6/9
Band Edge Compliance of RF Emission	11b/DSSS	11 Mbps	1/11
	11g/OFDM	54 Mbps	1/11
	11n(20MHz)/OFDM	65Mbps	1/11
	11n(40MHz)/OFDM	135Mbps	3/9

Note1: According exploratory test, EUT will have maximum output power in those data rate, so those data rate were used for all test.

Note2: This device use MIMO 2X2 antennas, for 802.11b/g mode, based exploratory test, when transmit with Antenna 1 have worse emissions, so the final radiated spurious emissions were tested with Antenna 1. For 802.11n mode, all the radiated spurious emissions and band edge test were performed with two antennas transmit synchronous.

4. TEST CONDITIONS AND RESULTS

4.1. Conducted Emissions Test

TEST CONFIGURATION

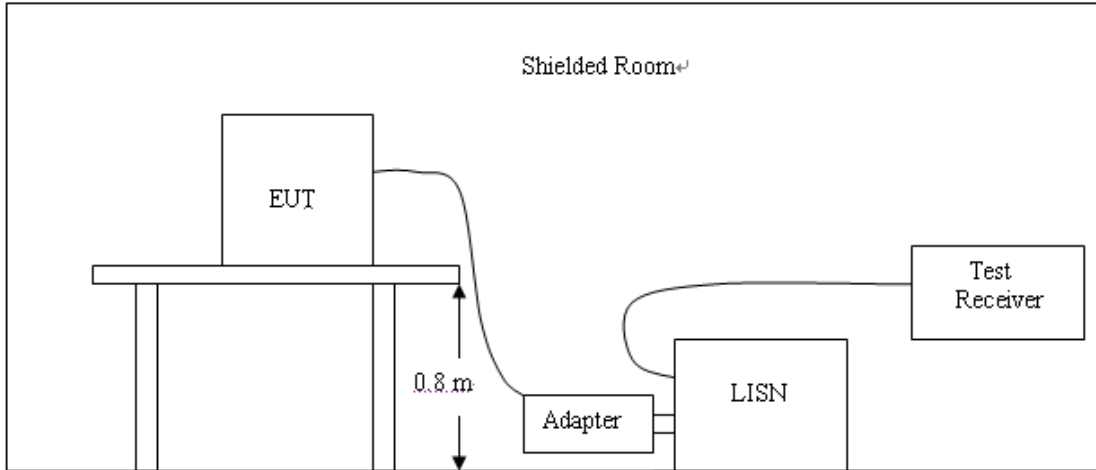

TEST PROCEDURE

For unintentional device, according to § 15.107(a) Line Conducted Emission Limits is as following:

Frequency (MHz)	Maximum RF Line Voltage (dB μ v)			
	CLASS A		CLASS B	
	Q.P.	Ave.	Q.P.	Ave.
0.15 - 0.50	79	66	66-56*	56-46*
0.50 - 5.00	73	60	56	46
5.00 - 30.0	73	60	60	50

* Decreasing linearly with the logarithm of the frequency

For intentional device, according to §15.207(a) Line Conducted Emission Limit is same as above table.

1. Please follow the guidelines in ANSI C63.4-2003.
2. The EUT was placed 0.4 meter from the conducting wall of the shielding room was kept at least 80 centimeters from any other grounded conducting surface.
3. Connect EUT to the power mains through a line impedance stabilization network (LISN).
4. All the support units are connecting to the other LISN.
5. The LISN provides 50 ohm coupling impedance for the measuring instrument.
6. The FCC states that a 50 ohm, 50 microhenry LISN should be used.
7. Both sides of AC line were checked for maximum conducted interference.
8. The frequency range from 150 kHz to 30 MHz was searched.
9. Set the test-receiver system to Peak Detect Function and specified bandwidth with Maximum Hold Mode.

The RBW/VBW for 150KHz to 30MHz: 9KHz

TEST RESULTS

Line 1:

SCAN TABLE: "Voltage (9K-30M)FIN"

Short Description: 150K-30M Voltage

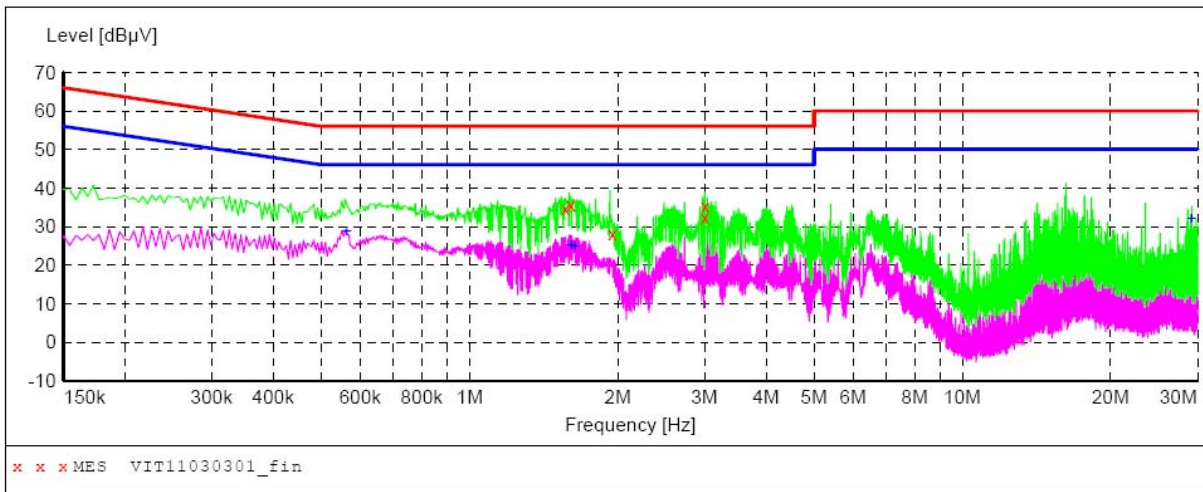

MEASUREMENT RESULT: "VIT11030301_fin"

3/3/2011 21:54

Frequency MHz	Level dBµV	Transd dB	Limit dBµV	Margin dB	Detector	Line	PE
1.563000	34.70	9.9	56	21.3	QP	L1	GND
1.603500	35.70	9.9	56	20.3	QP	L1	GND
1.950000	28.00	9.9	56	28.0	QP	L1	GND
3.003000	32.50	10.0	56	23.5	QP	L1	GND
3.007500	35.30	10.0	56	20.7	QP	L1	GND

MEASUREMENT RESULT: "VIT11030301_fin2"

3/3/2011 21:54

Frequency MHz	Level dBµV	Transd dB	Limit dBµV	Margin dB	Detector	Line	PE
0.564000	28.80	9.9	46	17.2	AV	L1	GND
1.608000	25.10	9.9	46	20.9	AV	L1	GND
1.635000	24.80	9.9	46	21.2	AV	L1	GND
29.233500	32.10	10.0	50	17.9	AV	L1	GND

Line 2:

SCAN TABLE: "Voltage (9K-30M) FIN"

Short Description: 150K-30M Voltage

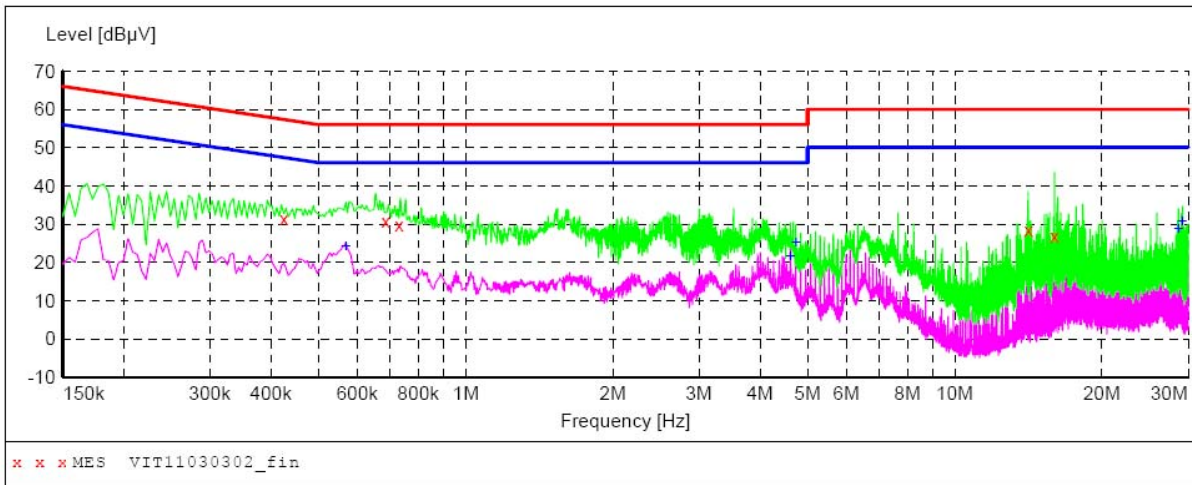

MEASUREMENT RESULT: "VIT11030302_fin"

3/3/2011 21:57

Frequency MHz	Level dBµV	Transd dB	Limit dBµV	Margin dB	Detector	Line	PE
0.424500	31.50	9.9	57	25.9	QP	N	GND
0.685500	30.80	9.9	56	25.2	QP	N	GND
0.730500	29.90	9.9	56	26.1	QP	N	GND
14.149500	28.50	9.8	60	31.5	QP	N	GND
15.985500	26.80	9.7	60	33.2	QP	N	GND

MEASUREMENT RESULT: "VIT11030302_fin2"

3/3/2011 21:57

Frequency MHz	Level dBµV	Transd dB	Limit dBµV	Margin dB	Detector	Line	PE
0.568500	24.30	9.9	46	21.7	AV	N	GND
4.614000	21.80	10.0	46	24.2	AV	N	GND
4.731000	25.10	10.0	46	20.9	AV	N	GND
28.684500	28.70	10.0	50	21.3	AV	N	GND
29.233500	30.90	10.0	50	19.1	AV	N	GND

4.2. Radiated Emission Test

TEST CONFIGURATION

(A) Radiated Emission Test Set-Up, Frequency Below 30MHz

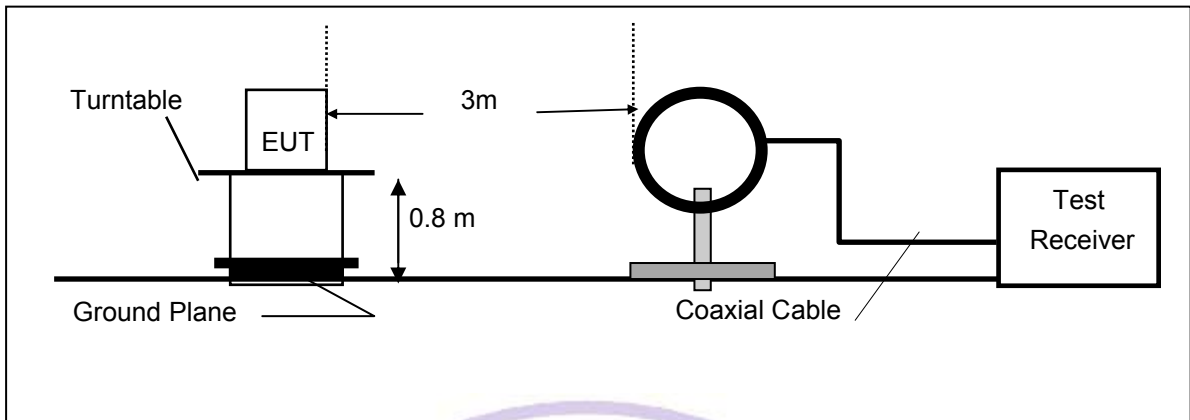

(B) Radiated Emission Test Set-Up, Frequency Below 1000MHz

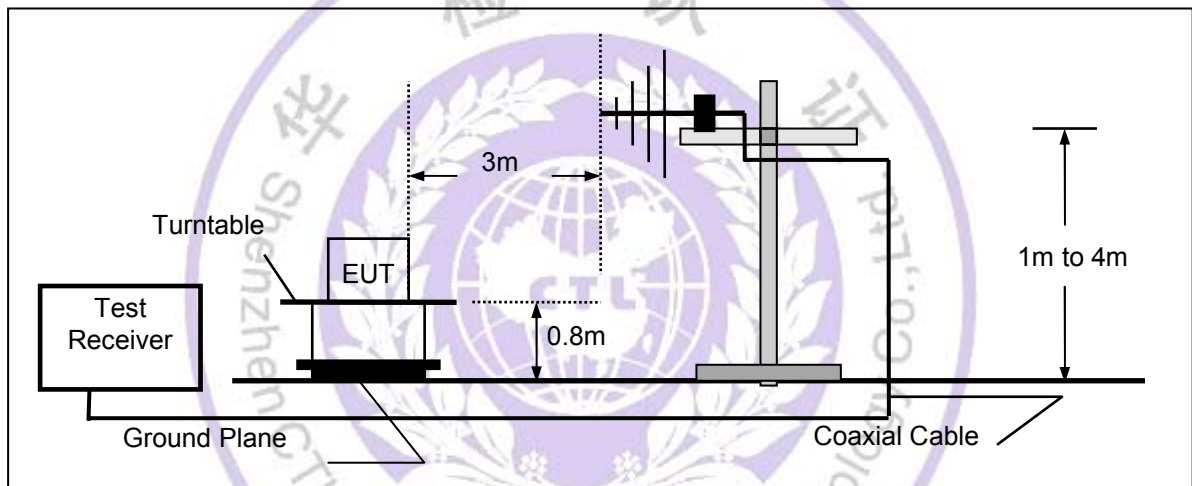

(C) Radiated Emission Test Set-Up, Frequency above 1000MHz

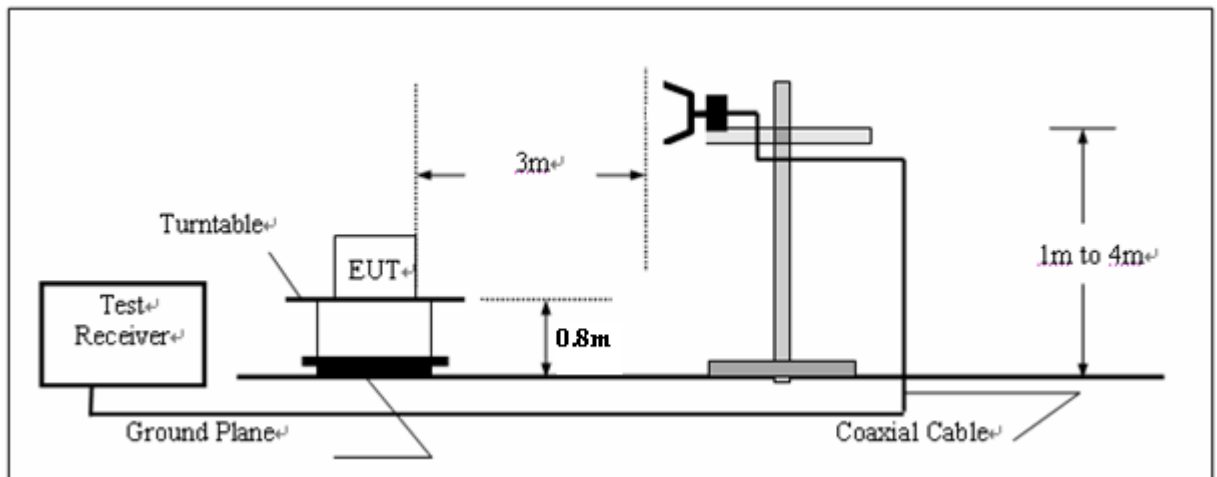

FIELD STRENGTH CALCULATION

The field strength is calculated by adding the Antenna Factor and Cable Factor and subtracting the Amplifier Gain and Duty Cycle Correction Factor(if any) from the measured reading. The basic equation with a sample calculation is as follows:

$$FS = RA + AF + CL - AG$$

Where FS = Field Strength	CL = Cable Attenuation Factor (Cable Loss)
RA = Reading Amplitude	AG = Amplifier Gain
AF = Antenna Factor	

TEST PROCEDURE

1. The testing follows FCC KDB Publication No. 558074 (Measurement Guidelines of DTS).
2. The EUT was placed on a turn table which is 0.8m above ground plane.
3. Maximum procedure was performed by raising the receiving antenna from 1m to 4m and rotating the turn table from 0° to 360° to acquire the highest emissions from EUT
4. And also, each emission was to be maximized by changing the polarization of receiving antenna both horizontal and vertical.
5. Span = wide enough to fully capture the emission being measured; RBW = 1 MHz for f > 1 GHz, 100 kHz for f < 1 GHz; VBW = RBW; Sweep = auto; Detector function = peak; Trace = max hold.
6. Repeat above procedures until all frequency measurements have been completed.

LIMIT

For unintentional device, according to § 15.109(a), except for Class A digital devices, the field strength of radiated emissions from unintentional radiators at a distance of 3 meters shall not exceed the following values:

Frequency (MHz)	Distance (Meters)	Radiated (dBµV/m)	Radiated (µV/m)
30-88	3	40.0	100
88-216	3	43.5	150
216-960	3	46.0	200
Above 960	3	54.0	500

For intentional device, according to § 15.209(a), the general requirement of field strength of radiated emissions from intentional radiators at a distance of 3 meters shall not exceed the above table. According to § 15.247(d), in any 100kHz bandwidth outside the frequency band in which the EUT is operating, the radio frequency power that is produced by the intentional radiator shall be at least 20dB below that in the 100kHz bandwidth within the band that contains the highest level of desired power.

TEST RESULTS

Below 1GHz:

The radiated measurement are performed the each test mode (b/g/n) and channel (low/mid/high), the datum recorded below (802.11b mode, the middle channel) is the worst case for all the test mode and channel.

SCAN TABLE: "test Field(30M-1G)QP"

Short Description:		Field Strength(30M-1G)					
Start	Stop	Step	Detector	Meas. Time	IF Bandw.	Transducer	
Frequency	Frequency	Width					
30.0 MHz	1.0 GHz	60.0 kHz	QuasiPeak	1.0 s	120 kHz	HL562 09	

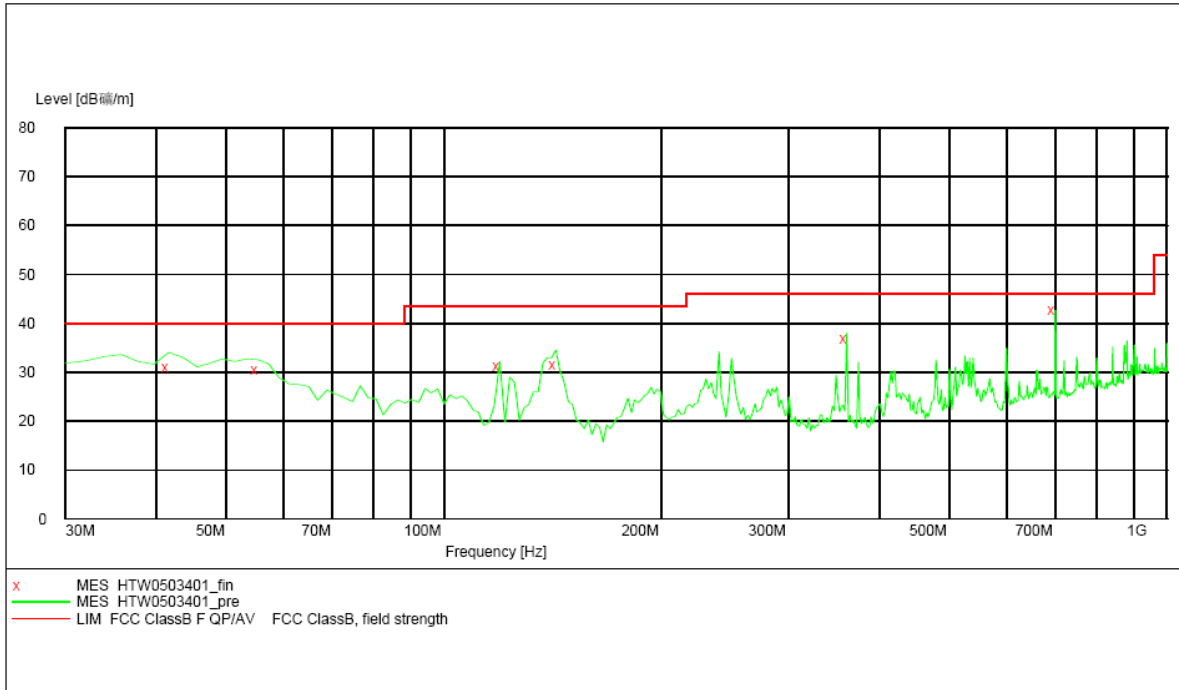

MEASUREMENT RESULT: "HTW0503401_fin"

Frequency (MHz)	Emission Level (dBuV/m)	Limit (dBuV/m)	Margin (dB)	Antenna Height (cm)	Detector	Antenna Factor (dB/m)	Cable Factor (dB)	Pre-amplifier (dB)	Correction Factor (dB/m)	Polarization
41.6	31.10	40.00	8.90	100	QP	14.20	6.40	-31.80	-11.20	V
55.27	30.60	40.00	9.40	150	QP	7.30	9.70	-34.80	-17.80	V
119.42	31.20	43.50	12.30	100	QP	11.60	7.50	-31.90	-12.80	V
142.75	31.50	43.50	12.00	150	QP	9.00	7.60	-32.00	-15.40	V
360.46	37.00	46.00	9.00	150	QP	13.90	8.50	-31.90	-9.50	V
699.96	42.70	46.00	3.30	150	QP	19.40	9.80	-32.00	-2.80	V

REMARKS :

- *Undetectable
- The IF bandwidth of EMI Test Receiver was 120KHz for measuring from 30 MHz to 1 GHz and 1 MHz for measuring above 1 GHz
- The Transd=Cabel loss +Antenna factor +pre-amplifier factor

SCAN TABLE: "test Field(30M-1G)QP"

Short Description: Field Strength(30M-1G)
 Start Stop Step Detector Meas. IF Transducer
 Frequency Frequency Width Time Bandw.
 30.0 MHz 1.0 GHz 60.0 kHz QuasiPeak 1.0 s 120 kHz HL562 09

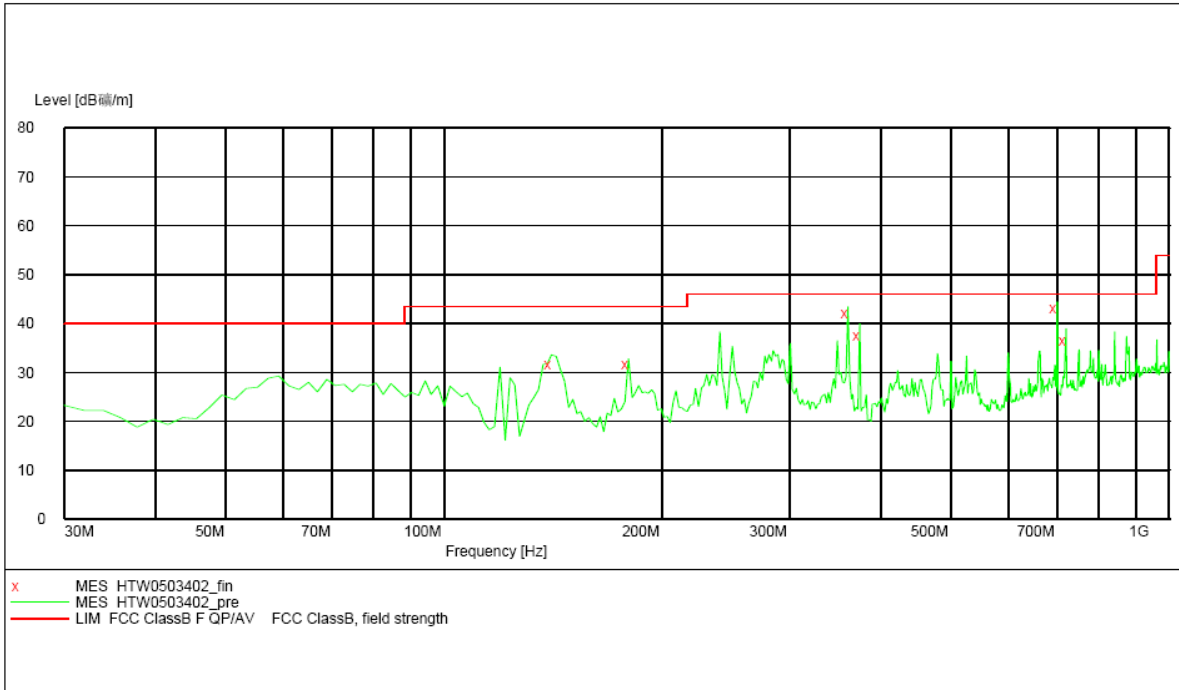

MEASUREMENT RESULT: "HTW0503402_fin"

Frequency (MHz)	Emission Level (dBuV/m)	Limit (dBuV/m)	Margin (dB)	Antenna Height (cm)	Detector	Antenna Factor (dB/m)	Cable Factor (dB)	Pre-amplifier (dB)	Correction Factor (dB/m)	Polarization
140.80	31.50	43.50	12.0	300	QP	9.3	7.4	-32.0	-15.3	H
179.68	31.60	43.50	11.9	100	QP	7.3	7.9	-32.0	-16.8	H
360.46	42.10	46.00	3.9	100	QP	13.9	8.5	-31.9	-9.5	H
374.07	37.50	46.00	8.5	100	QP	14.2	8.5	-31.9	-9.2	H
699.96	43.20	46.00	2.8	100	QP	19.4	9.8	-32.0	-2.8	H
720.08	36.50	46.00	9.5	100	QP	19.3	9.7	-31.9	-2.9	H

REMARKS :

- *Undetectable
- The IF bandwidth of EMI Test Receiver was 120KHz for measuring from 30 MHz to 1 GHz and 1 MHz for measuring above 1 GHz
- The Transd=Cabel loss +Antenna factor +pre-amplifier factor

Above 1GHz:
802.11b CH1

ANTENNA POLARITY & TEST DISTANCE: HORIZONTAL AT 3 M

No.	Frequency (MHz)	Emission Level (dBuV/m)		Limit (dBuV/m)	Margin (dB)	Antenna Height (m)	Table Angle (Degree)	Raw Value (dBuV)	Antenna Factor (dB/m)	Cable Factor (dB)	Pre-amplifier (dB)	Correction Factor (dB/m)
1	2390.00	50.83	PK	74.00	23.17	1.00 H	200	54.23	28.3	4.90	36.6	-3.40
1	2390.00	42.11	AV	54.00	11.89	1.00 H	200	45.41	28.3	4.90	36.6	-3.40
2	*2412.00	106.46	PK			1.00 H	333	109.86	28.3	4.90	36.6	-3.40
2	*2412.00	93.10	AV			1.00 H	333	96.50	28.3	4.90	36.6	-3.40
3	4824.00	49.23	PK	74.00	24.77	1.00 H	125	46.03	32.7	7.00	36.5	3.20
3	4824.00	39.00	AV	54.00	15.00	1.00 H	125	35.80	32.7	7.00	36.5	3.20
4	7236.00	57.21	PK	74.00	16.79	1.00 H	66	47.81	35.8	8.90	35.3	9.40
4	7236.00	43.35	AV	54.00	10.65	1.00 H	66	33.95	35.8	8.90	35.3	9.40
5	9648.00	55.23	PK	74.00	18.77	1.00 H	264	42.63	37.2	10.20	34.8	12.60
5	9648.00	43.00	AV	54.00	11.00	1.00 H	264	30.40	37.2	10.20	34.8	12.60

ANTENNA POLARITY & TEST DISTANCE: VERTICAL AT 3 M

No.	Frequency (MHz)	Emission Level (dBuV/m)		Limit (dBuV/m)	Margin (dB)	Antenna Height (m)	Table Angle (Degree)	Raw Value (dBuV)	Antenna Factor (dB/m)	Cable Factor (dB)	Pre-amplifier (dB)	Correction Factor (dB/m)
1	2390.00	53.89	PK	74.00	20.11	1.0	236	57.29	28.3	4.90	36.6	-3.40
1	2390.00	44.49	AV	54.00	9.51	1.0	236	47.89	28.3	4.90	36.6	-3.40
2	*2412.00	109.96	PK			1.0	100	113.36	28.3	4.90	36.6	-3.40
2	*2412.00	96.21	AV			1.0	100	99.55	28.3	4.90	36.6	-3.40
3	4824.00	58.23	PK	74.00	15.77	1.0	312	55.03	32.7	7.00	36.5	3.20
3	4824.00	43.00	AV	54.00	11.00	1.0	312	39.80	32.7	7.00	36.5	3.20
4	7236.00	60.12	PK	74.00	13.88	1.0	46	50.72	35.8	8.90	35.3	9.40
4	7236.00	45.17	AV	54.00	8.83	1.0	46	35.77	35.8	8.90	35.3	9.40
5	9648.00	58.64	PK	74.00	15.36	1.0	108	46.04	37.2	10.20	34.8	12.60
5	9648.00	43.57	AV	54.00	10.43	1.0	108	30.97	37.2	10.20	34.8	12.60

REMARKS:

1. Emission level (dBuV/m) = Raw Value (dBuV) + Correction Factor (dB/m)
2. Correction Factor (dB/m) = Antenna Factor (dB/m) + Cable Factor (dB) - Pre-amplifier Factor
3. The other emission levels were very low against the limit.
4. Margin value = Limit value - Emission level.
5. The limit value is defined as per 15.247
6. "*" : Fundamental frequency
7. For Wireless 802.11b mode at 11Mbps.

802.11b CH6

ANTENNA POLARITY & TEST DISTANCE: HORIZONTAL AT 3 M											
No.	Frequency (MHz)	Emission Level (dBuV/m)	Limit (dBuV/m)	Margin (dB)	Antenna Height (m)	Table Angle (Degree)	Raw Value (dBuV)	Antenna Factor (dB/m)	Cable Factor (dB)	Pre-amplifier (dB)	Correction Factor (dB/m)
1	*2437.00	105.30 PK			1.00 H	153	108.50	28.3	5.10	-36.6	-3.20
1	*2437.00	92.30 AV			1.00 H	153	95.50	28.3	5.10	-36.6	-3.20
2	4874.00	46.40 PK	74.00	27.60	1.00 H	202	43.20	32.3	7.60	-36.5	3.40
2	4874.00	35.00 AV	54.00	19.00	1.00 H	202	31.60	32.3	7.60	-36.5	3.40
3	7311.00	51.10 PK	74.00	22.90	1.00 H	355	41.70	36.1	8.60	-35.3	9.40
3	7311.00	39.00 AV	54.00	15.00	1.00 H	355	29.60	36.1	8.60	-35.3	9.40
4	9748.00	58.20 PK	74.00	15.80	1.00 H	28	45.60	37.2	10.20	-34.8	12.60
4	9748.00	46.20 AV	54.00	7.80	1.00 H	28	33.60	37.2	10.20	-34.8	12.60

ANTENNA POLARITY & TEST DISTANCE: VERTICAL AT 3 M											
No.	Frequency (MHz)	Emission Level (dBuV/m)	Limit (dBuV/m)	Margin (dB)	Antenna Height (m)	Table Angle (Degree)	Raw Value (dBuV)	Antenna Factor (dB/m)	Cable Factor (dB)	Pre-amplifier (dB)	Correction Factor (dB/m)
1	*2437.00	107.70 PK			1.00 V	121	110.90	28.3	5.10	-36.6	-3.20
1	*2437.00	96.20 AV			1.00 V	121	98.40	28.3	5.10	-36.6	-3.20
2	4874.00	47.00 PK	74.00	27.00	1.00 V	97	43.60	32.3	7.60	-36.5	3.40
2	4874.00	35.10 AV	54.00	18.90	1.00 V	97	32.10	32.3	7.60	-36.5	3.40
3	7311.00	55.10 PK	74.00	22.90	1.00 V	288	45.70	36.1	8.60	-35.3	9.40
3	7311.00	39.10 AV	54.00	14.90	1.00 V	288	29.70	36.1	8.60	-35.3	9.40
4	9748.00	59.30 PK	74.00	14.70	1.00 V	89	46.70	37.2	10.20	-34.8	12.60
4	9748.00	46.20 AV	54.00	7.80	1.00 V	89	33.60	37.2	10.20	-34.8	12.60

- REMARKS:**
1. Emission level (dBuV/m)=Raw Value(dBuV) + Correction Factor(dB/m)
 2. Correction Factor (dB/m) = Antenna Factor (dB/m) + Cable Factor (dB))+ Pre-amplifier Factor
 3. The other emission levels were very low against the limit.
 4. Margin value = Limit value- Emission level.
 5. The limit value is defined as per 15.247
 6. “* “: Fundamental frequency
 7. For Wireless 802.11b mode at 11Mbps.

802.11b CH11

ANTENNA POLARITY & TEST DISTANCE: HORIZONTAL AT 3 M

No.	Frequency (MHz)	Emission Level (dBuV/m)	Limit (dBuV/m)	Margin (dB)	Antenna Height (m)	Table Angle (Degree)	Raw Value (dBuV)	Antenna Factor (dB/m)	Cable Factor (dB)	Pre-amplifier (dB)	Correction Factor (dB/m)
1	*2462.00	104.90 PK			1.00 H	154	108.20	28.6	4.70	-36.6	-3.30
1	*2462.00	91.70 AV			1.00 H	154	95.00	28.6	4.70	-36.6	-3.30
2	2483.50	36.70 PK	74.00	37.30	1.00 H	146	40.00	28.6	4.70	-36.6	-3.30
2	2483.50	23.10 AV	54.00	30.90	1.00 H	146	26.40	28.6	4.70	-36.6	-3.30
3	4022.04	45.20 PK	74.00	28.80	1.00 H	341	43.30	32.2	6.20	-36.5	1.90
3	4022.04	33.30 AV	54.00	20.70	1.00 H	341	31.40	32.2	6.20	-36.5	1.90
4	4924.00	47.10 PK	74.00	26.90	1.00 H	100	43.30	33.0	7.00	-36.2	3.80
4	4924.00	35.10 AV	54.00	18.90	1.00 H	100	31.30	33.0	7.00	-36.2	3.80
5	7386.00	54.40 PK	74.00	19.60	1.00 H	190	45.00	36.2	8.50	-35.3	9.40
5	7386.00	42.30 AV	54.00	11.70	1.00 H	190	32.90	36.2	8.50	-35.3	9.40
6	9848.00	59.00 PK	74.00	15.00	1.00 H	113	46.40	37.2	10.20	-34.8	12.60
6	9848.00	46.40 AV	54.00	7.60	1.00 H	113	33.80	37.2	10.20	-34.8	12.60

ANTENNA POLARITY & TEST DISTANCE: VERTICAL AT 3 M

No.	Frequency (MHz)	Emission Level (dBuV/m)	Limit (dBuV/m)	Margin (dB)	Antenna Height (m)	Table Angle (Degree)	Raw Value (dBuV)	Antenna Factor (dB/m)	Cable Factor (dB)	Pre-amplifier (dB)	Correction Factor (dB/m)
1	*2462.00	107.90 PK			1.00 V	247	111.20	28.6	4.70	-36.6	-3.30
1	*2462.00	97.60 AV			1.00 V	247	100.90	28.6	4.70	-36.6	-3.30
2	2483.50	53.40 PK	74.00	20.60	1.00 V	150	56.70	28.6	4.70	-36.6	-3.30
2	2483.50	40.80 AV	54.00	13.20	1.00 V	150	44.10	28.6	4.70	-36.6	-3.30
3	4022.04	45.10 PK	74.00	28.90	1.00 V	299	43.20	32.2	6.20	-36.5	1.90
3	4022.04	33.30 AV	54.00	20.70	1.00 V	299	31.40	32.2	6.20	-36.5	1.90
4	4924.00	46.40 PK	74.00	27.60	1.00 V	90	42.60	33.0	7.00	-36.2	3.80
4	4924.00	35.10 AV	54.00	18.90	1.00 V	90	31.30	33.0	7.00	-36.2	3.80
5	7386.00	55.00 PK	74.00	19.00	1.00 V	29	45.60	36.2	8.50	-35.3	9.40
5	7386.00	42.60 AV	54.00	11.40	1.00 V	29	33.20	36.2	8.50	-35.3	9.40
6	9848.00	58.30 PK	74.00	15.70	1.00 V	222	45.70	37.2	10.20	-34.8	12.60
6	9848.00	46.10 AV	54.00	7.90	1.00 V	222	33.50	37.2	10.20	-34.8	12.60

- REMARKS:**
1. Emission level (dBuV/m)=Raw Value(dBuV) + Correction Factor(dB/m)
 2. Correction Factor (dB/m) = Antenna Factor (dB/m) + Cable Factor (dB))+ Pre-amplifier Factor
 3. The other emission levels were very low against the limit.
 4. Margin value = Limit value- Emission level.
 5. The limit value is defined as per 15.247
 6. "*" : Fundamental frequency
 7. For Wireless 802.11b mode at 11Mbps.

802.11g CH1

ANTENNA POLARITY & TEST DISTANCE: HORIZONTAL AT 3 M

No.	Frequency (MHz)	Emission Level (dBuV/m)		Limit (dBuV/m)	Margin (dB)	Antenna Height (m)	Table Angle (Degree)	Raw Value (dBuV)	Antenna Factor (dB/m)	Cable Factor (dB)	Pre-amplifier (dB)	Correction Factor (dB/m)
1	2390.00	62.83	PK	74.00	11.17	1.00 H	247	66.13	28.3	5.00	36.6	-3.30
1	2390.00	42.22	AV	54.00	11.78	1.00 H	247	45.52	28.3	5.00	36.6	-3.30
2	*2412.00	106.36	PK			1.00 H	100	109.66	28.3	5.00	36.6	-3.30
2	*2412.00	92.53	AV			1.00 H	100	95.83	28.3	5.00	36.6	-3.30
3	4824.00	50.23	PK	74.00	23.77	1.00 H	89	46.43	32.7	7.30	36.2	3.80
3	4824.00	36.88	AV	54.00	17.12	1.00 H	89	33.08	32.7	7.30	36.2	3.80
4	7236.00	54.00	PK	74.00	20.00	1.00 H	345	44.60	35.8	8.90	35.3	9.40
4	7236.00	40.13	AV	54.00	13.87	1.00 H	345	30.73	35.8	8.90	35.3	9.40
5	9648.00	51.55	PK	74.00	22.45	1.00 H	121	38.95	37.2	10.20	34.8	12.60
5	9648.00	39.78	AV	54.00	14.22	1.00 H	121	27.18	37.2	10.20	34.8	12.60

ANTENNA POLARITY & TEST DISTANCE: VERTICAL AT 3 M

No.	Frequency (MHz)	Emission Level (dBuV/m)		Limit (dBuV/m)	Margin (dB)	Antenna Height (m)	Table Angle (Degree)	Raw Value (dBuV)	Antenna Factor (dB/m)	Cable Factor (dB)	Pre-amplifier (dB)	Correction Factor (dB/m)
1	2390.00	69.55	PK	74.00	4.450	1.00 V	288	72.85	28.3	5.00	36.6	-3.30
1	2390.00	42.25	AV	54.00	11.75	1.00 V	288	45.55	28.3	5.00	36.6	-3.30
2	*2412.00	104.29	PK			1.00 V	69	107.59	28.3	5.00	36.6	-3.30
2	*2412.00	92.24	AV			1.00 V	69	95.54	28.3	5.00	36.6	-3.30
3	4824.00	55.54	PK	74.00	18.46	1.00 V	291	51.74	32.7	7.30	36.2	3.80
3	4824.00	40.12	AV	54.00	13.88	1.00 V	291	36.32	32.7	7.30	36.2	3.80
4	7236.00	60.45	PK	74.00	13.55	1.00 V	360	51.05	35.8	8.90	35.3	9.40
4	7236.00	42.77	AV	54.00	11.23	1.00 V	360	33.37	35.8	8.90	35.3	9.40
5	9648.00	57.68	PK	74.00	16.32	1.00 V	155	45.08	37.2	10.20	34.8	12.60
5	9648.00	40.44	AV	54.00	13.56	1.00 V	155	27.84	37.2	10.20	34.8	12.60

- REMARKS:**
1. Emission level (dBuV/m)=Raw Value(dBuV) + Correction Factor(dB/m)
 2. Correction Factor (dB/m) = Antenna Factor (dB/m) + Cable Factor (dB))+ Pre-amplifier Factor
 3. The other emission levels were very low against the limit.
 4. Margin value = Limit value- Emission level.
 5. The limit value is defined as per 15.247
 6. "*" : Fundamental frequency
 7. For Wireless 802.11g mode at 54Mbps.

802.11g CH6

ANTENNA POLARITY & TEST DISTANCE: HORIZONTAL AT 3 M

No.	Frequency (MHz)	Emission Level (dBuV/m)	Limit (dBuV/m)	Margin (dB)	Antenna Height (m)	Table Angle (Degree)	Raw Value (dBuV)	Antenna Factor (dB/m)	Cable Factor (dB)	Pre-amplifier (dB)	Correction Factor (dB/m)
1	*2437.00	104.40 PK			1.00 H	100	107.60	28.3	5.10	-36.6	-3.20
1	*2437.00	87.00 AV			1.00 H	100	90.20	28.3	5.10	-36.6	-3.20
2	4874.00	46.40 PK	74.00	27.60	1.00 H	214	43.00	32.8	7.10	-36.5	3.40
2	4874.00	35.10 AV	54.00	18.90	1.00 H	214	31.70	32.8	7.10	-36.5	3.40
3	7311.00	54.70 PK	74.00	19.30	1.00 H	0	45.30	36.1	8.60	-35.3	9.40
3	7311.00	42.30 AV	54.00	11.70	1.00 H	0	3290	36.1	8.60	-35.3	9.40
4	9748.00	57.80 PK	74.00	16.20	1.00 H	163	45.20	37.2	10.20	-34.8	12.60
4	9748.00	46.30 AV	54.00	7.70	1.00 H	163	33.70	37.2	10.20	-34.8	12.60

ANTENNA POLARITY & TEST DISTANCE: VERTICAL AT 3 M

No.	Frequency (MHz)	Emission Level (dBuV/m)	Limit (dBuV/m)	Margin (dB)	Antenna Height (m)	Table Angle (Degree)	Raw Value (dBuV)	Antenna Factor (dB/m)	Cable Factor (dB)	Pre-amplifier (dB)	Correction Factor (dB/m)
1	*2437.00	107.50 PK			1.00 V	122	110.70	28.3	5.10	-36.6	-3.20
1	*2437.00	94.80 AV			1.00 V	122	98.00	28.3	5.10	-36.6	-3.20
2	4874.00	46.10 PK	74.00	27.90	1.00 V	100	42.70	32.8	7.10	-36.5	3.40
2	4874.00	35.10 AV	54.00	18.90	1.00 V	100	31.70	32.8	7.10	-36.5	3.40
3	7311.00	54.90 PK	74.00	19.10	1.00 V	356	45.50	36.1	8.60	-35.3	9.40
3	7311.00	42.40 AV	54.00	11.60	1.00 V	356	33.00	36.1	8.60	-35.3	9.40
4	9748.00	58.60 PK	74.00	15.40	1.00 V	26	46.00	37.2	10.20	-34.8	12.60
4	9748.00	48.20 AV	54.00	7.80	1.00 V	26	35.60	37.2	10.20	-34.8	12.60

- REMARKS:**
1. Emission level (dBuV/m) = Raw Value (dBuV) + Correction Factor (dB/m)
 2. Correction Factor (dB/m) = Antenna Factor (dB/m) + Cable Factor (dB) + Pre-amplifier Factor
 3. The other emission levels were very low against the limit.
 4. Margin value = Limit value - Emission level.
 5. The limit value is defined as per 15.247
 6. "*" : Fundamental frequency
 7. For Wireless 802.11g mode at 54Mbps.

802.11g CH11

ANTENNA POLARITY & TEST DISTANCE: HORIZONTAL AT 3 M

No.	Frequency (MHz)	Emission Level (dBuV/m)	Limit (dBuV/m)	Margin (dB)	Antenna Height (m)	Table Angle (Degree)	Raw Value (dBuV)	Antenna Factor (dB/m)	Cable Factor (dB)	Pre-amplifier (dB)	Correction Factor (dB/m)
1	*2462.00	99.50 PK			1.00 H	156	102.80	28.2	5.10	-36.6	-3.30
1	*2462.00	85.80 AV			1.00 H	156	89.10	28.2	5.10	-36.6	-3.30
2	2483.50	47.70 PK	74.00	26.30	1.00 H	191	51.00	28.2	5.10	-36.6	-3.30
2	2483.50	30.10 AV	54.00	23.90	1.00 H	191	33.40	28.2	5.10	-36.6	-3.30
3	4924.00	46.90 PK	74.00	27.10	1.00 H	198	43.10	33.0	7.00	-36.2	3.80
3	4924.00	34.90 AV	54.00	19.10	1.00 H	198	31.10	33.0	7.00	-36.2	3.80
4	7386.00	54.70 PK	74.00	19.30	1.00 H	90	45.30	36.2	8.50	-35.3	9.40
4	7386.00	42.30 AV	54.00	11.70	1.00 H	90	32.90	36.2	8.50	-35.3	9.40
5	9848.00	58.60 PK	74.00	15.40	1.00 H	124	46.00	37.3	10.10	-34.8	12.60
5	9848.00	46.20 AV	54.00	7.80	1.00 H	124	33.60	37.3	10.10	-34.8	12.60

ANTENNA POLARITY & TEST DISTANCE: VERTICAL AT 3 M

No.	Frequency (MHz)	Emission Level (dBuV/m)	Limit (dBuV/m)	Margin (dB)	Antenna Height (m)	Table Angle (Degree)	Raw Value (dBuV)	Antenna Factor (dB/m)	Cable Factor (dB)	Pre-amplifier (dB)	Correction Factor (dB/m)
1	*2462.00	101.50 PK			1.00 V	125	105.80	28.2	5.10	-36.6	-3.30
1	*2462.00	89.10 AV			1.00 V	125	94.40	28.2	5.10	-36.6	-3.30
2	2483.50	65.70 PK	74.00	8.30	1.00 V	348	69.00	28.2	5.10	-36.6	-3.30
2	2483.50	50.90 AV	54.00	3.10	1.00 V	348	54.20	28.2	5.10	-36.6	-3.30
3	4924.00	46.10 PK	74.00	27.90	1.00 V	96	42.30	33.0	7.00	-36.2	3.80
3	4924.00	34.80 AV	54.00	19.20	1.00 V	96	31.00	33.0	7.00	-36.2	3.80
4	7386.00	54.40 PK	74.00	19.60	1.00 V	35	45.00	36.2	8.50	-35.3	9.40
4	7386.00	42.30 AV	54.00	11.70	1.00 V	35	32.90	36.2	8.50	-35.3	9.40
5	9848.00	58.60 PK	74.00	15.40	1.00 V	37	46.00	37.3	10.10	-34.8	12.60
5	9848.00	46.20 AV	54.00	7.80	1.00 V	37	33.60	37.3	10.10	-34.8	12.60

- REMARKS:**
1. Emission level (dBuV/m) = Raw Value (dBuV) + Correction Factor (dB/m)
 2. Correction Factor (dB/m) = Antenna Factor (dB/m) + Cable Factor (dB) + Pre-amplifier Factor
 3. The other emission levels were very low against the limit.
 4. Margin value = Limit value - Emission level.
 5. The limit value is defined as per 15.247
 6. " * " : Fundamental frequency
 7. For Wireless 802.11g mode at 54Mbps.

802.11n (20MHz) Channel 1

ANTENNA POLARITY & TEST DISTANCE: HORIZONTAL AT 3 M

No.	Frequency (MHz)	Emission Level (dBuV/m)		Limit (dBuV/m)	Margin (dB)	Antenna Height (m)	Table Angle (Degree)	Raw Value (dBuV)	Antenna Factor (dB/m)	Cable Factor (dB)	Pre-amplifier (dB)	Correction Factor (dB/m)
1	2390.00	67.10	PK	74.00	6.90	1.00 H	144	70.40	28.3	5.00	36.6	-3.30
1	2390.00	34.50	AV	54.00	19.50	1.00 H	144	37.80	28.3	5.00	36.6	-3.30
2	*2412.00	104.43	PK			1.00 H	256	107.73	28.3	5.00	36.6	-3.30
2	*2412.00	84.00	AV			1.00 H	256	87.30	28.3	5.00	36.6	-3.30
3	4824.00	52.23	PK	74.00	21.77	1.00 H	88	48.43	32.7	7.30	36.2	3.80
3	4824.00	41.47	AV	54.00	12.53	1.00 H	88	37.67	32.7	7.30	36.2	3.80
4	7236.00	53.88	PK	74.00	20.12	1.00 H	331	44.48	35.8	8.90	35.3	9.40
4	7236.00	41.26	AV	54.00	12.74	1.00 H	331	31.86	35.8	8.90	35.3	9.40
5	9648.00	55.14	PK	74.00	18.86	1.00 H	105	42.54	37.2	10.20	34.8	12.60
5	9648.00	42.69	AV	54.00	11.31	1.00 H	105	30.09	37.2	10.20	34.8	12.60

ANTENNA POLARITY & TEST DISTANCE: VERTICAL AT 3 M

No.	Frequency (MHz)	Emission Level (dBuV/m)		Limit (dBuV/m)	Margin (dB)	Antenna Height (m)	Table Angle (Degree)	Raw Value (dBuV)	Antenna Factor (dB/m)	Cable Factor (dB)	Pre-amplifier (dB)	Correction Factor (dB/m)
1	2390.00	68.01	PK	74.00	5.99	1.00 V	125	71.31	28.3	5.00	36.6	-3.30
1	2390.00	45.27	AV	54.00	8.73	1.00 V	125	48.57	28.3	5.00	36.6	-3.30
2	*2412.00	105.40	PK			1.00 V	236	108.70	28.3	5.00	36.6	-3.30
2	*2412.00	87.72	AV			1.00 V	236	91.02	28.3	5.00	36.6	-3.30
3	4824.00	53.39	PK	74.00	20.61	1.00 V	179	49.59	32.7	7.30	36.2	3.80
3	4824.00	42.07	AV	54.00	11.93	1.00 V	179	38.27	32.7	7.30	36.2	3.80
4	7236.00	54.51	PK	74.00	19.49	1.00 V	313	45.11	35.8	8.90	35.3	9.40
4	7236.00	41.56	AV	54.00	12.44	1.00 V	313	32.16	35.8	8.90	35.3	9.40
5	9648.00	56.71	PK	74.00	17.29	1.00 V	5	44.11	37.2	10.20	34.8	12.60
5	9648.00	43.25	AV	54.00	10.75	1.00 V	5	30.65	37.2	10.20	34.8	12.60

- REMARKS:**
1. Emission level (dBuV/m)=Raw Value(dBuV) + Correction Factor(dB/m)
 2. Correction Factor (dB/m) = Antenna Factor (dB/m) + Cable Factor (dB) -Pre-amplifier Factor
 3. The other emission levels were very low against the limit.
 4. Margin value = Limit value- Emission level.
 5. The limit value is defined as per 15.247
 6. "*" : Fundamental frequency

802.11n (20MHz) Channel 6

ANTENNA POLARITY & TEST DISTANCE: HORIZONTAL AT 3 M

No.	Frequency (MHz)	Emission Level (dBuV/m)		Limit (dBuV/m)	Margin (dB)	Antenna Height (m)	Table Angle (Degree)	Raw Value (dBuV)	Antenna Factor (dB/m)	Cable Factor (dB)	Pre-amplifier (dB)	Correction Factor (dB/m)
1	*2437.00	101.88	PK			1.00 H	223	105.08	28.3	5.10	36.6	-3.20
1	*2437.00	85.07	AV			1.00 H	122	88.27	28.3	5.10	36.6	-3.20
2	4874.00	47.56	PK	74.00	26.44	1.00 H	5	44.16	32.8	7.10	36.5	3.40
2	4874.00	36.91	AV	54.00	17.09	1.00 H	5	33.51	32.8	7.10	36.5	3.40
3	7311.00	51.72	PK	74.00	22.28	1.00 H	124	42.32	36.1	8.60	35.3	9.40
3	7311.00	40.66	AV	54.00	13.34	1.00 H	124	31.26	36.1	8.60	35.3	9.40
4	9748.00	53.78	PK	74.00	20.22	1.00 H	325	41.18	37.2	10.20	34.8	12.60
4	9748.00	42.04	AV	54.00	11.96	1.00 H	325	29.44	37.2	10.20	34.8	12.60

ANTENNA POLARITY & TEST DISTANCE: VERTICAL AT 3 M

No.	Frequency (MHz)	Emission Level (dBuV/m)		Limit (dBuV/m)	Margin (dB)	Antenna Height (m)	Table Angle (Degree)	Raw Value (dBuV)	Antenna Factor (dB/m)	Cable Factor (dB)	Pre-amplifier (dB)	Correction Factor (dB/m)
1	*2437.00	102.97	PK			1.00 V	125	106.17	28.3	5.10	36.6	-3.20
1	*2437.00	86.11	AV			1.00 V	125	89.31	28.3	5.10	36.6	-3.20
2	4874.00	48.23	PK	74.00	25.77	1.00 V	289	44.83	32.8	7.10	36.5	3.40
2	4874.00	36.97	AV	54.00	17.03	1.00 V	289	33.57	32.8	7.10	36.5	3.40
3	7311.00	55.46	PK	74.00	18.54	1.00 V	0	46.06	36.1	8.60	35.3	9.40
3	7311.00	40.57	AV	54.00	13.43	1.00 V	0	31.17	36.1	8.60	35.3	9.40
4	9748.00	52.36	PK	74.00	21.64	1.00 V	180	39.76	37.2	10.20	34.8	12.60
4	9748.00	42.89	AV	54.00	11.11	1.00 V	180	30.29	37.2	10.20	34.8	12.60

- REMARKS:**
1. Emission level (dBuV/m) = Raw Value (dBuV) + Correction Factor (dB/m)
 2. Correction Factor (dB/m) = Antenna Factor (dB/m) + Cable Factor (dB) - Pre-amplifier Factor
 3. The other emission levels were very low against the limit.
 4. Margin value = Limit value - Emission level.
 5. The limit value is defined as per 15.247
 6. "*" : Fundamental frequency

802.11n (20MHz) Channel 11

ANTENNA POLARITY & TEST DISTANCE: HORIZONTAL AT 3 M

No.	Frequency (MHz)	Emission Level (dBuV/m)		Limit (dBuV/m)	Margin (dB)	Antenna Height (m)	Table Angle (Degree)	Raw Value (dBuV)	Antenna Factor (dB/m)	Cable Factor (dB)	Pre-amplifier (dB)	Correction Factor (dB/m)
1	*2462.00	96.84	PK			1.00 H	122	100.14	28.2	5.10	36.6	-3.30
1	*2462.00	87.73	AV			1.00 H	122	91.03	28.2	5.10	36.6	-3.30
2	2483.50	45.50	PK	74.00	28.50	1.00 H	300	48.80	28.2	5.10	36.6	-3.30
2	2483.50	37.65	AV	54.00	16.35	1.00 H	300	40.95	28.2	5.10	36.6	-3.30
3	4924.00	49.28	PK	74.00	24.72	1.00 H	156	45.48	33.0	7.00	36.2	3.80
3	4924.00	35.00	AV	54.00	19.00	1.00 H	156	31.20	33.0	7.00	36.2	3.80
4	7386.00	50.36	PK	74.00	23.64	1.00 H	334	40.96	36.2	8.50	35.3	9.40
4	7386.00	39.12	AV	54.00	14.88	1.00 H	334	29.72	36.2	8.50	35.3	9.40
5	9848.00	52.17	PK	74.00	21.83	1.00 H	278	39.57	37.3	10.10	34.8	12.60
5	9848.00	40.23	AV	54.00	13.77	1.00 H	278	27.63	37.3	10.10	34.8	12.60

ANTENNA POLARITY & TEST DISTANCE: VERTICAL AT 3 M

No.	Frequency (MHz)	Emission Level (dBuV/m)		Limit (dBuV/m)	Margin (dB)	Antenna Height (m)	Table Angle (Degree)	Raw Value (dBuV)	Antenna Factor (dB/m)	Cable Factor (dB)	Pre-amplifier (dB)	Correction Factor (dB/m)
1	*2462.00	103.54	PK			1.00 V	125	106.84	28.2	5.10	36.6	-3.30
1	*2462.00	88.32	AV			1.00 V	125	91.62	28.2	5.10	36.6	-3.30
2	2483.50	58.08	PK	74.00	15.92	1.00 V	189	61.38	28.2	5.10	36.6	-3.30
2	2483.50	37.91	AV	54.00	16.09	1.00 V	189	41.21	28.2	5.10	36.6	-3.30
3	4924.00	52.12	PK	74.00	21.88	1.00 V	347	48.32	33.0	7.00	36.2	3.80
3	4924.00	36.17	AV	54.00	17.83	1.00 V	347	32.37	33.0	7.00	36.2	3.80
4	7386.00	54.12	PK	74.00	19.88	1.00 V	12	44.72	36.2	8.50	35.3	9.40
4	7386.00	40.54	AV	54.00	13.46	1.00 V	12	31.14	36.2	8.50	35.3	9.40
5	9848.00	54.10	PK	74.00	19.90	1.00 V	208	41.50	37.3	10.10	34.8	12.60
5	9848.00	41.23	AV	54.00	12.77	1.00 V	208	28.63	37.3	10.10	34.8	12.60

- REMARKS:**
1. Emission level (dBuV/m) = Raw Value (dBuV) + Correction Factor (dB/m)
 2. Correction Factor (dB/m) = Antenna Factor (dB/m) + Cable Factor (dB) - Pre-amplifier Factor
 3. The other emission levels were very low against the limit.
 4. Margin value = Limit value - Emission level.
 5. The limit value is defined as per 15.247
 6. " * " : Fundamental frequency

802.11n (40MHz) Channel 3

ANTENNA POLARITY & TEST DISTANCE: HORIZONTAL AT 3 M

No.	Frequency (MHz)	Emission Level (dBuV/m)		Limit (dBuV/m)	Margin (dB)	Antenna Height (m)	Table Angle (Degree)	Raw Value (dBuV)	Antenna Factor (dB/m)	Cable Factor (dB)	Pre-amplifier (dB)	Correction Factor (dB/m)
1	2390.00	65.16	PK	74.00	8.84	1.00 H	236	68.46	28.3	5.00	36.6	-3.30
1	2390.00	37.13	AV	54.00	16.87	1.00 H	236	40.43	28.3	5.00	36.6	-3.30
2	*2422.00	100.03	PK			1.00 H	100	103.33	28.3	5.00	36.6	-3.30
2	*2422.00	82.21	AV			1.00 H	100	85.51	28.3	5.00	36.6	-3.30
3	4844.00	50.88	PK	74.00	23.12	1.00 H	197	47.08	32.7	7.30	36.2	3.80
3	4844.00	40.26	AV	54.00	13.74	1.00 H	197	36.46	32.7	7.30	36.2	3.80
4	7266.00	53.00	PK	74.00	21.00	1.00 H	306	43.60	35.8	8.90	35.3	9.40
4	7266.00	41.08	AV	54.00	12.92	1.00 H	306	31.68	35.8	8.90	35.3	9.40
5	9688.00	54.72	PK	74.00	19.28	1.00 H	17	42.12	37.2	10.20	34.8	12.60
5	9688.00	42.25	AV	54.00	11.75	1.00 H	17	29.65	37.2	10.20	34.8	12.60

ANTENNA POLARITY & TEST DISTANCE: VERTICAL AT 3 M

No.	Frequency (MHz)	Emission Level (dBuV/m)		Limit (dBuV/m)	Margin (dB)	Antenna Height (m)	Table Angle (Degree)	Raw Value (dBuV)	Antenna Factor (dB/m)	Cable Factor (dB)	Pre-amplifier (dB)	Correction Factor (dB/m)
1	2390.00	69.89	PK	74.00	4.11	1.00 V	122	73.19	28.3	5.00	36.6	-3.30
1	2390.00	38.06	AV	54.00	15.94	1.00 V	122	41.36	28.3	5.00	36.6	-3.30
2	*2422.00	103.44	PK			1.00 V	189	106.74	28.3	5.00	36.6	-3.30
2	*2422.00	83.93	AV			1.00 V	189	87.23	28.3	5.00	36.6	-3.30
3	4844.00	52.77	PK	74.00	21.23	1.00 V	257	48.97	32.7	7.30	36.2	3.80
3	4844.00	40.03	AV	54.00	13.97	1.00 V	257	36.23	32.7	7.30	36.2	3.80
4	7266.00	53.89	PK	74.00	20.11	1.00 V	155	44.49	35.8	8.90	35.3	9.40
4	7266.00	41.56	AV	54.00	12.44	1.00 V	155	32.16	35.8	8.90	35.3	9.40
5	9688.00	55.99	PK	74.00	18.01	1.00 V	334	43.39	37.2	10.20	34.8	12.60
5	9688.00	43.14	AV	54.00	10.86	1.00 V	334	30.54	37.2	10.20	34.8	12.60

- REMARKS:**
1. Emission level (dBuV/m)=Raw Value(dBuV) + Correction Factor(dB/m)
 2. Correction Factor (dB/m) = Antenna Factor (dB/m) + Cable Factor (dB) -Pre-amplifier Factor
 3. The other emission levels were very low against the limit.
 4. Margin value = Limit value- Emission level.
 5. The limit value is defined as per 15.247
 6. “* “: Fundamental frequency

802.11n (40MHz) Channel 6

ANTENNA POLARITY & TEST DISTANCE: HORIZONTAL AT 3 M												
No.	Frequency (MHz)	Emission Level (dBuV/m)		Limit (dBuV/m)	Margin (dB)	Antenna Height (m)	Table Angle (Degree)	Raw Value (dBuV)	Antenna Factor (dB/m)	Cable Factor (dB)	Pre-amplifier (dB)	Correction Factor (dB/m)
1	*2437.00	99.15	PK			1.00 H	100	102.35	28.3	5.10	36.6	-3.20
1	*2437.00	84.36	AV			1.00 H	100	87.56	28.3	5.10	36.6	-3.20
2	4874.00	49.11	PK	74.00	24.89	1.00 H	198	45.71	32.3	7.60	36.5	3.40
2	4874.00	38.82	AV	54.00	15.18	1.00 H	198	35.42	32.3	7.60	36.5	3.40
3	7311.00	52.22	PK	74.00	21.78	1.00 H	203	42.82	36.1	8.60	35.3	9.40
3	7311.00	41.00	AV	54.00	13.00	1.00 H	203	31.60	36.1	8.60	35.3	9.40
4	9748.00	53.91	PK	74.00	20.09	1.00 H	56	41.31	37.2	10.20	34.8	12.60
4	9748.00	42.17	AV	54.00	11.83	1.00 H	56	29.57	37.2	10.20	34.8	12.60

ANTENNA POLARITY & TEST DISTANCE: VERTICAL AT 3 M												
No.	Frequency (MHz)	Emission Level (dBuV/m)		Limit (dBuV/m)	Margin (dB)	Antenna Height (m)	Table Angle (Degree)	Raw Value (dBuV)	Antenna Factor (dB/m)	Cable Factor (dB)	Pre-amplifier (dB)	Correction Factor (dB/m)
1	*2437.00	101.14	PK			1.00 V	122	104.34	28.3	5.10	36.6	-3.20
1	*2437.00	86.51	AV			1.00 V	122	89.71	28.3	5.10	36.6	-3.20
2	4874.00	49.99	PK	74.00	24.01	1.00 V	96	46.59	32.3	7.60	36.5	3.40
2	4874.00	38.97	AV	54.00	15.03	1.00 V	96	35.57	32.3	7.60	36.5	3.40
3	7311.00	54.36	PK	74.00	19.64	1.00 V	26	44.96	36.1	8.60	35.3	9.40
3	7311.00	40.57	AV	54.00	13.43	1.00 V	26	31.17	36.1	8.60	35.3	9.40
4	9748.00	52.79	PK	74.00	21.21	1.00 V	299	40.19	37.2	10.20	34.8	12.60
4	9748.00	42.07	AV	54.00	11.93	1.00 V	299	29.47	37.2	10.20	34.8	12.60

- REMARKS:**
1. Emission level (dBuV/m) = Raw Value (dBuV) + Correction Factor (dB/m)
 2. Correction Factor (dB/m) = Antenna Factor (dB/m) + Cable Factor (dB) - Pre-amplifier Factor
 3. The other emission levels were very low against the limit.
 4. Margin value = Limit value - Emission level.
 5. The limit value is defined as per 15.247
 6. "*" : Fundamental frequency

802.11n (40MHz) Channel 9

ANTENNA POLARITY & TEST DISTANCE: HORIZONTAL AT 3 M												
No.	Frequency (MHz)	Emission Level (dBuV/m)		Limit (dBuV/m)	Margin (dB)	Antenna Height (m)	Table Angle (Degree)	Raw Value (dBuV)	Antenna Factor (dB/m)	Cable Factor (dB)	Pre-amplifier (dB)	Correction Factor (dB/m)
1	*2452.00	95.09	PK			1.00 H	125	98.29	28.2	5.20	36.6	-3.20
1	*2452.00	83.71	AV			1.00 H	125	85.91	28.2	5.20	36.6	-3.20
2	2483.50	54.61	PK	74.00	19.39	1.00 H	312	57.91	28.2	5.10	36.6	-3.30
2	2483.50	39.24	AV	54.00	14.76	1.00 H	312	42.54	28.2	5.10	36.6	-3.30
3	4904.00	49.97	PK	74.00	24.03	1.00 H	258	46.17	33.0	7.00	36.2	3.80
3	4904.00	35.67	AV	54.00	18.33	1.00 H	258	31.87	33.0	7.00	36.2	3.80
4	7356.00	51.12	PK	74.00	22.88	1.00 H	12	41.72	36.2	8.50	35.3	9.40
4	7356.00	39.99	AV	54.00	14.01	1.00 H	12	30.59	36.2	8.50	35.3	9.40
5	9808.00	52.72	PK	74.00	21.28	1.00 H	100	40.12	37.3	10.10	34.8	12.60
5	9808.00	41.23	AV	54.00	12.77	1.00 H	100	28.63	37.3	10.10	34.8	12.60

ANTENNA POLARITY & TEST DISTANCE: VERTICAL AT 3 M												
No.	Frequency (MHz)	Emission Level (dBuV/m)		Limit (dBuV/m)	Margin (dB)	Antenna Height (m)	Table Angle (Degree)	Raw Value (dBuV)	Antenna Factor (dB/m)	Cable Factor (dB)	Pre-amplifier (dB)	Correction Factor (dB/m)
1	*2452.00	100.99	PK			1.00 V	125	104.19	28.2	5.20	36.6	-3.20
1	*2452.00	84.50	AV			1.00 V	125	87.70	28.2	5.20	36.6	-3.20
2	2483.50	61.38	PK	74.00	12.62	1.00 V	300	64.68	28.2	5.10	36.6	-3.30
2	2483.50	39.63	AV	54.00	14.37	1.00 V	300	42.93	28.2	5.10	36.6	-3.30
3	4904.00	53.56	PK	74.00	20.44	1.00 V	346	49.76	33.0	7.00	36.2	3.80
3	4904.00	37.15	AV	54.00	16.85	1.00 V	346	33.35	33.0	7.00	36.2	3.80
4	7356.00	54.99	PK	74.00	19.01	1.00 V	157	45.59	36.2	8.50	35.3	9.40
4	7356.00	41.47	AV	54.00	12.53	1.00 V	157	32.07	36.2	8.50	35.3	9.40
5	9808.00	55.51	PK	74.00	18.49	1.00 V	287	42.91	37.3	10.10	34.8	12.60
5	9808.00	42.12	AV	54.00	11.88	1.00 V	287	29.52	37.3	10.10	34.8	12.60

- REMARKS:**
1. Emission level (dBuV/m) = Raw Value (dBuV) + Correction Factor (dB/m)
 2. Correction Factor (dB/m) = Antenna Factor (dB/m) + Cable Factor (dB) - Pre-amplifier Factor
 3. The other emission levels were very low against the limit.
 4. Margin value = Limit value - Emission level.
 5. The limit value is defined as per 15.247
 6. " * " : Fundamental frequency

Note:

The field strength is calculated by adding the Antenna Factor, Cable Factor & Pre-amplifier. The basic equation with a sample calculation is as follows:

Final Test Level = Receiver Reading + Antenna Factor + Cable Factor - Pre-amplifier Factor.

Remark: No any other emissions level which are attenuated less than 20dB below the limit

According to 15.31(o), The amplitude of spurious emissions from intentional radiators and emissions from unintentional radiators which are attenuated more than 20 dB below the permissible value need not be reported unless specifically required elsewhere in this Part.

Hence there no other emissions have been reported.

According to 15.31(o), The amplitude of spurious emissions from intentional radiators and emissions from unintentional radiators which are attenuated more than 20 dB below the permissible value need not be reported unless specifically required elsewhere in this Part.

Hence there no other emissions have been reported.

Remark:

- 1). As shown in Section, for frequencies above 1000 MHz. the above field strength limits are based on average limits. However, the peak field strength of any emission shall not exceed the maximum permitted average limits specified above by more than 20 dB under any condition of modulation.
- 2). The test only perform the EUT in transmitting status since the test frequencies were over 1GHz only required transmitting status.
- 3) Pre-Scan has been conducted to determine the worst-case mode from all possible Combinations between available modulations, data rates and antenna ports, and found the EUT worse case mode: 802.11b (11MHz), 802.11g (54MHz)
- 4) For this intentional radiator operates below 25 GHz. The spectrum shall be investigated to the tenth harmonic of the highest fundamental frequency. And above the 4th harmonic of this intentional radiator, the disturbance is very low. So the test result only displays to 4th harmonic.



4.3. 6dB Bandwidth Measurement

TEST CONFIGURATION

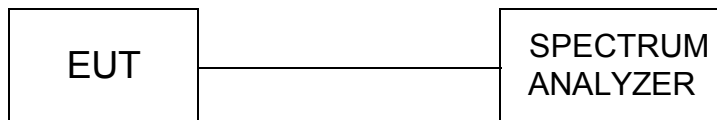

TEST PROCEDURE

1. The testing follows FCC KDB Publication No. 558074 (Measurement Guidelines of DTS).
2. The RF output of EUT was connected to the spectrum analyzer by a low loss cable.
3. Make the measurement with the spectrum analyzer's resolution bandwidth (RBW) = 100 kHz. In order to make an accurate measurement, set the span greater than RBW. The 6 dB bandwidth must be greater than 500 kHz.
4. The marker-delta reading at this point is the 6 dB bandwidth of the emission.

LIMIT

For digital modulation systems, the minimum 6 dB bandwidth shall be at least 500 kHz.

TEST RESULTS

Mode	CHANNEL	6 dB BANDWIDTH (MHz)		MINIMUM LIMIT (MHz)	PASS/FAIL
		Ant 1	Ant 2		
802.11b	1	10.42	10.42	0.5	PASS
	6	10.52	10.52	0.5	PASS
	11	9.92	9.92	0.5	PASS
802.11g	1	16.43	16.43	0.5	PASS
	6	16.43	16.43	0.5	PASS
	11	16.38	16.48	0.5	PASS
802.11n HT20	1	16.82	16.82	0.5	PASS
	6	16.82	16.82	0.5	PASS
	11	17.02	16.92	0.5	PASS
802.11n HT40	3	35.06	35.56	0.5	PASS
	6	35.06	35.06	0.5	PASS
	9	35.06	35.66	0.5	PASS

For 802.11b:

CH1 @ANT 1

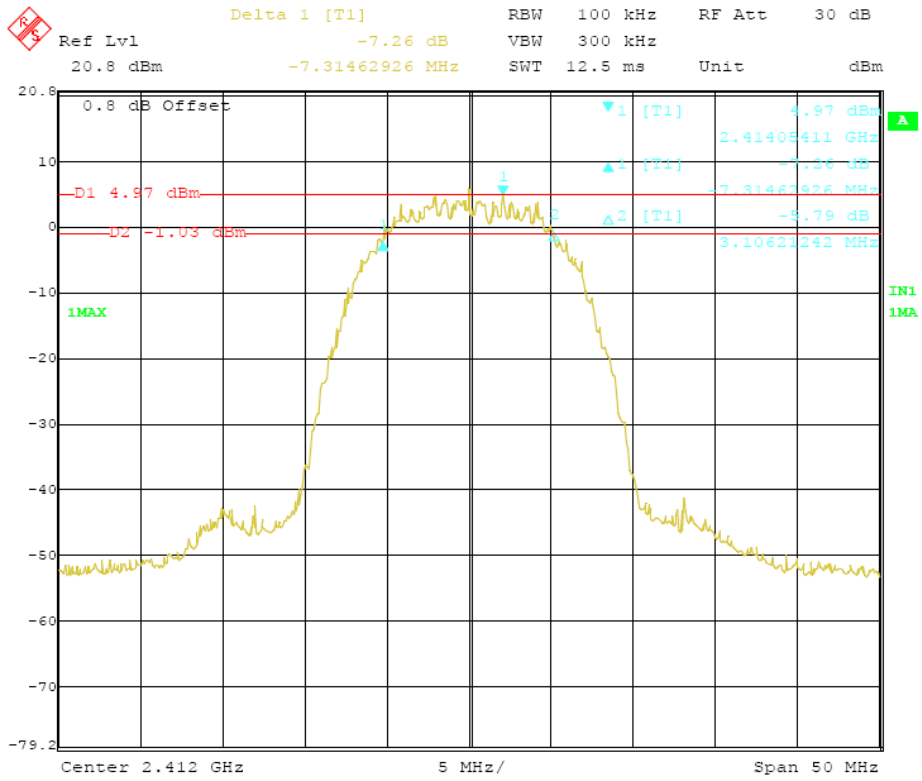

CH2 @ANT 2

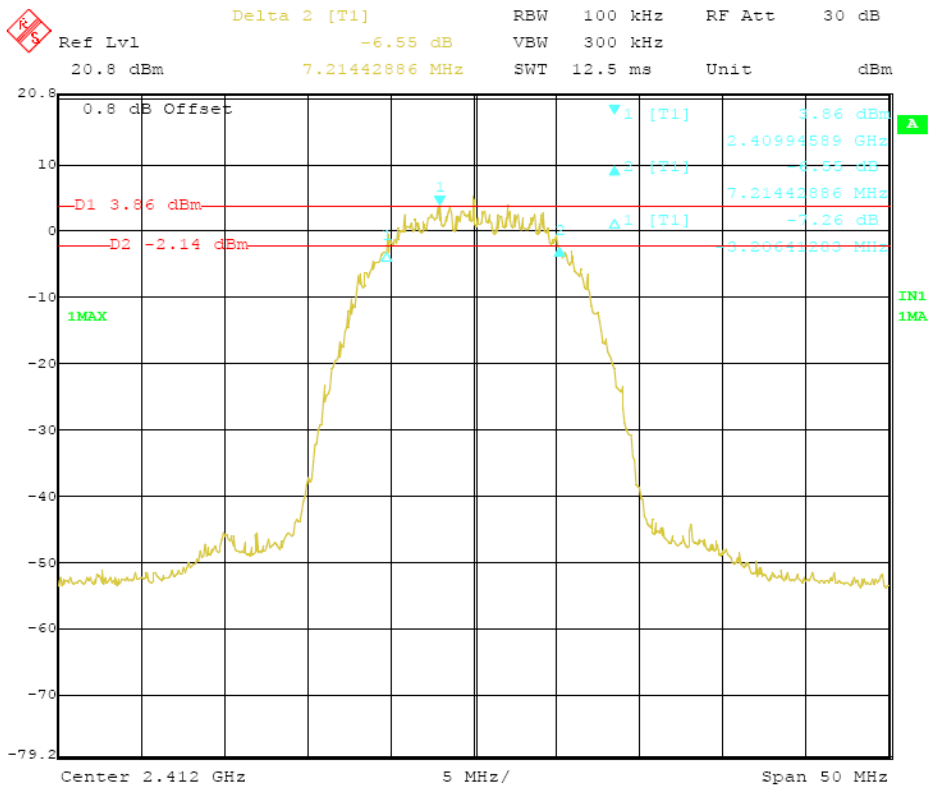

CH6 @ANT 1

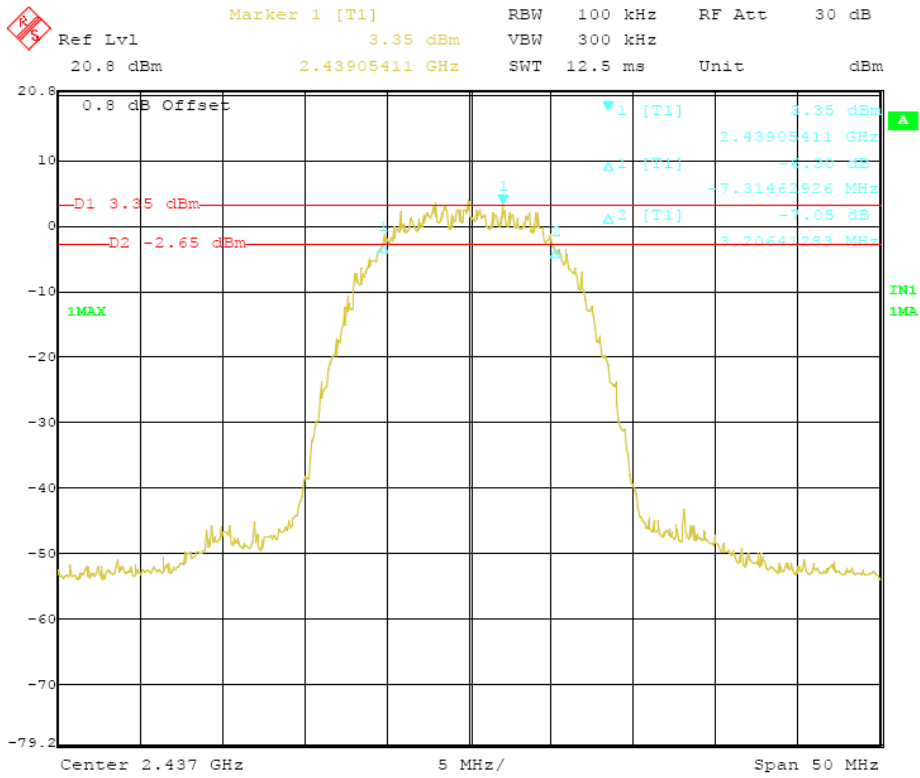

CH6 @ANT 2

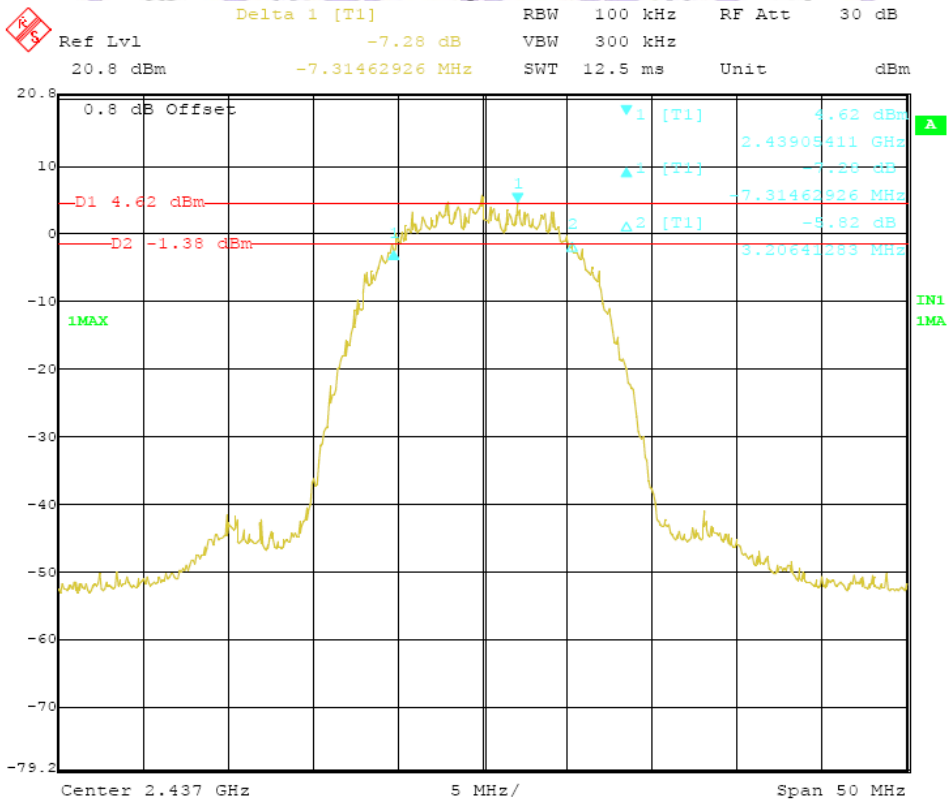

CH11 @ANT 1

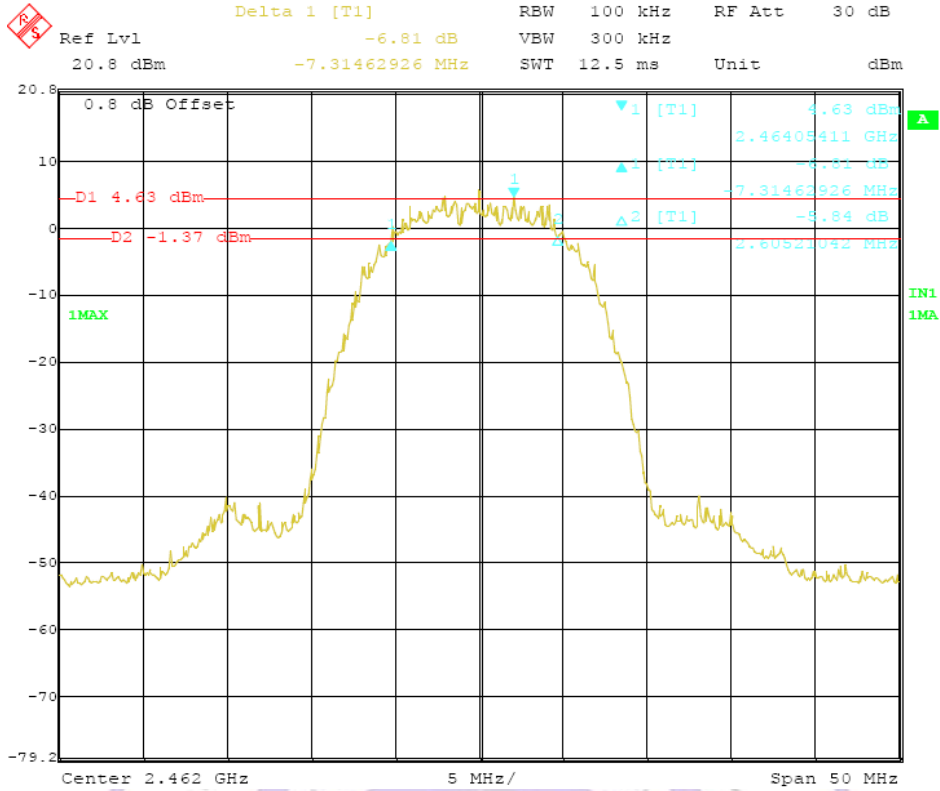

CH11 @ANT 2

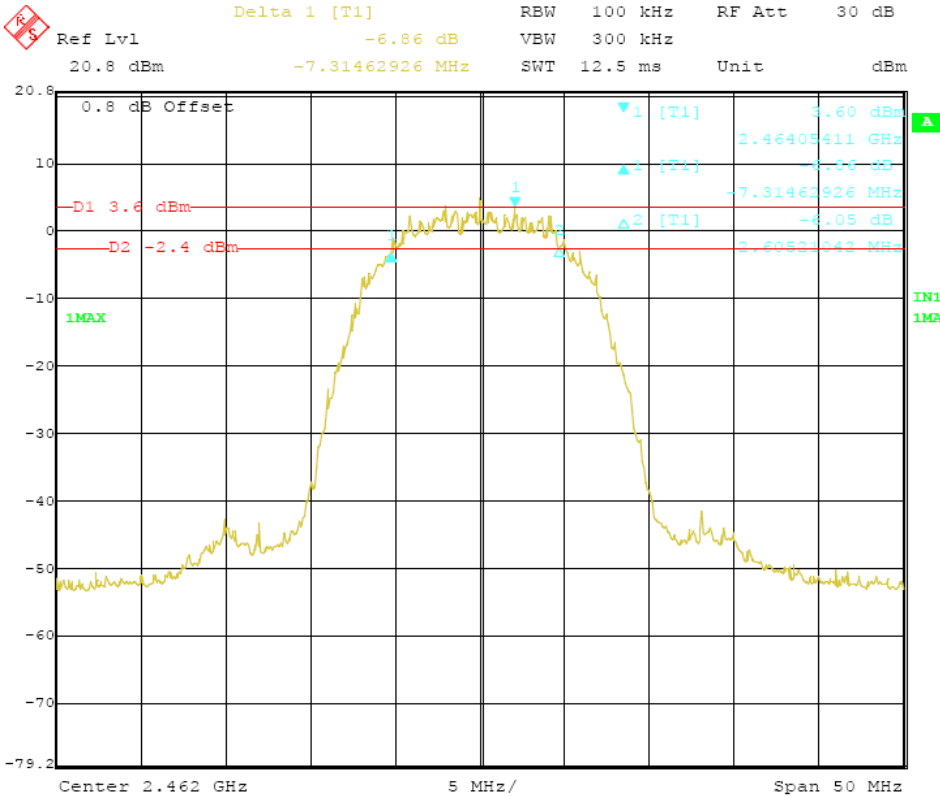

For 802.11g:

CH1 @ANT 1

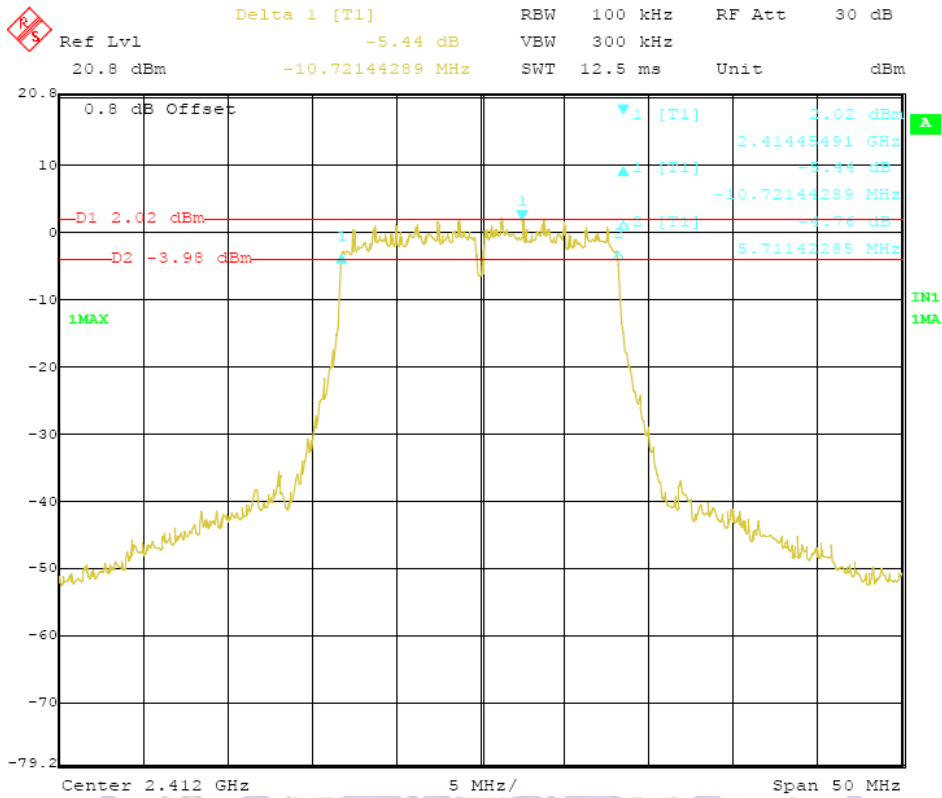

CH1 @ANT 2

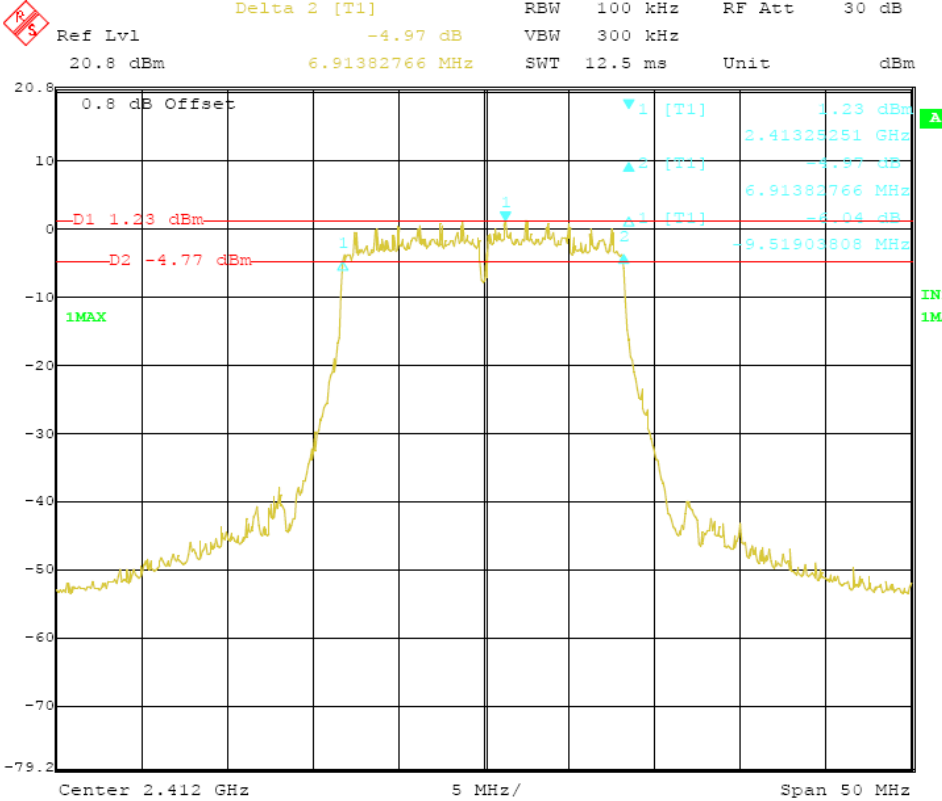

CH6 @ ANT 1

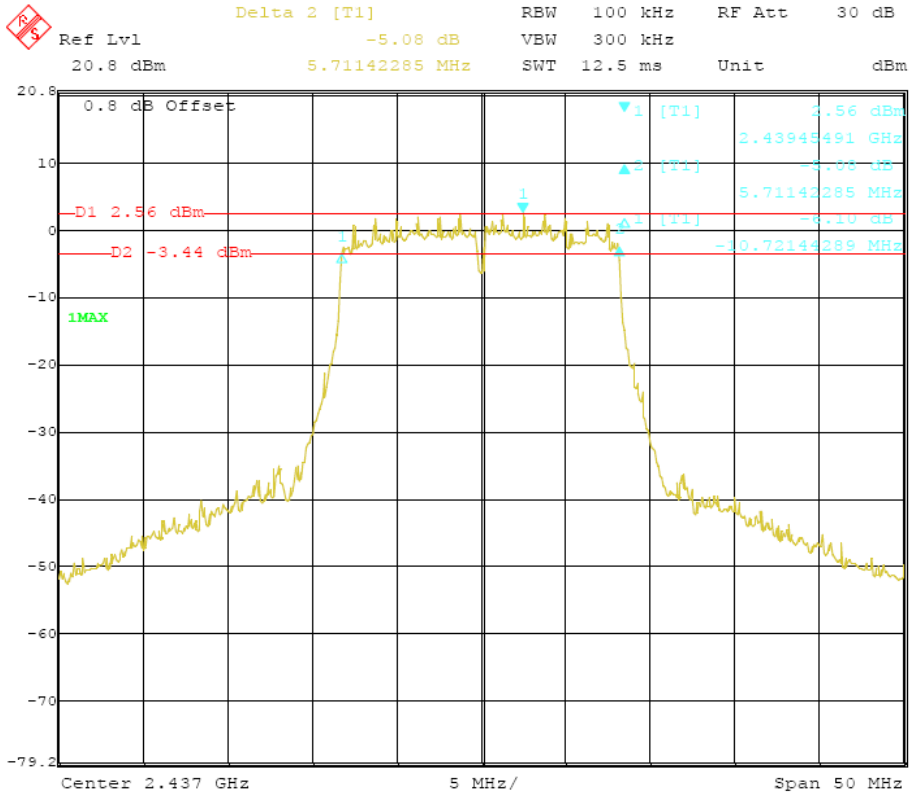

CH6 @ ANT 2

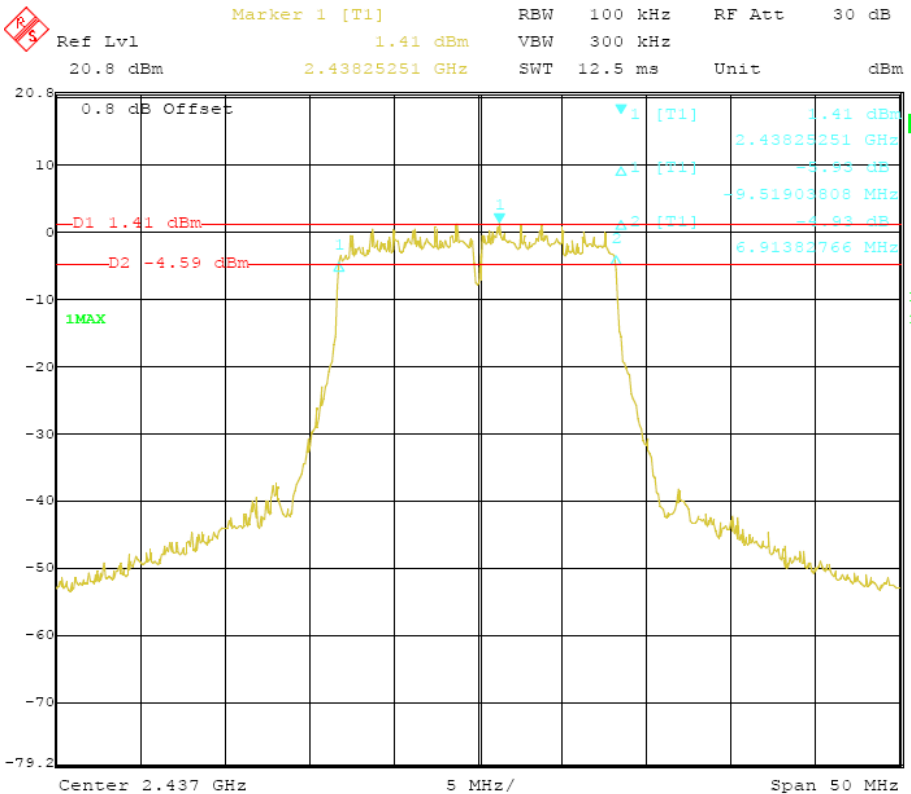

CH11 @ANT 1

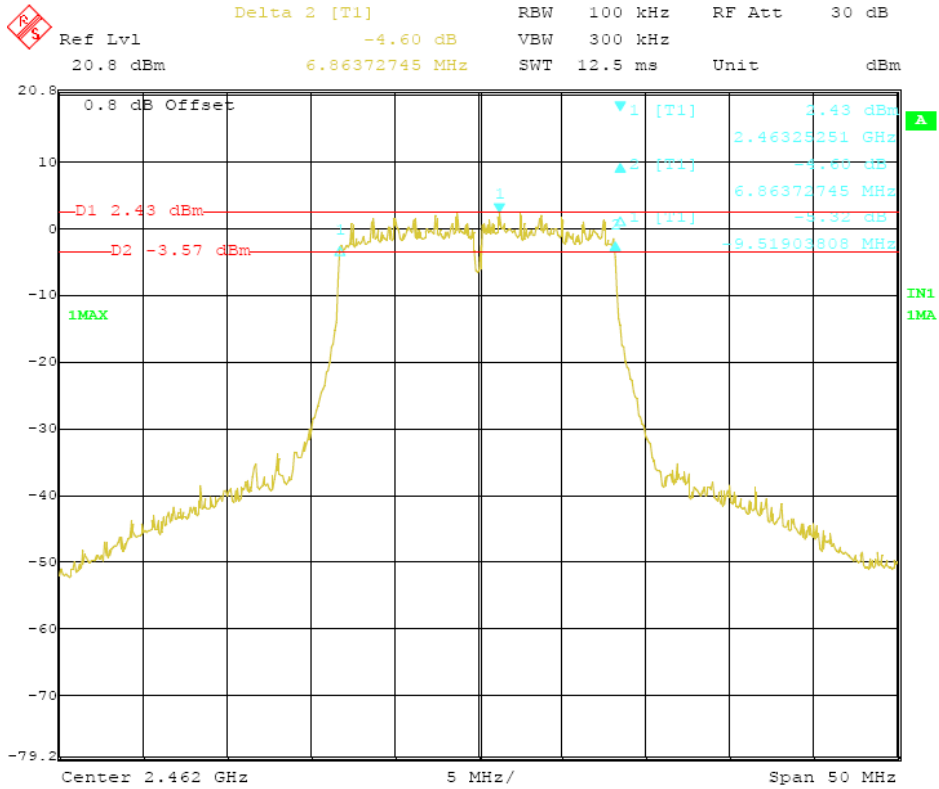

CH11 @ANT 2

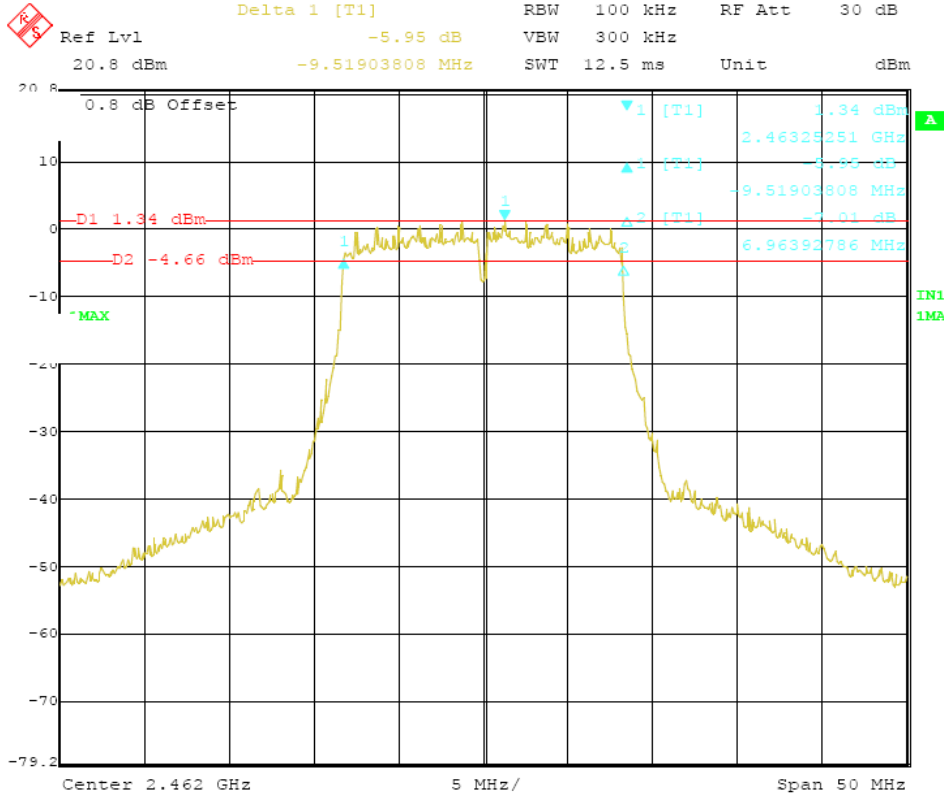

For 802.11n (20MHz) Mode:

CH1 @ANT 1

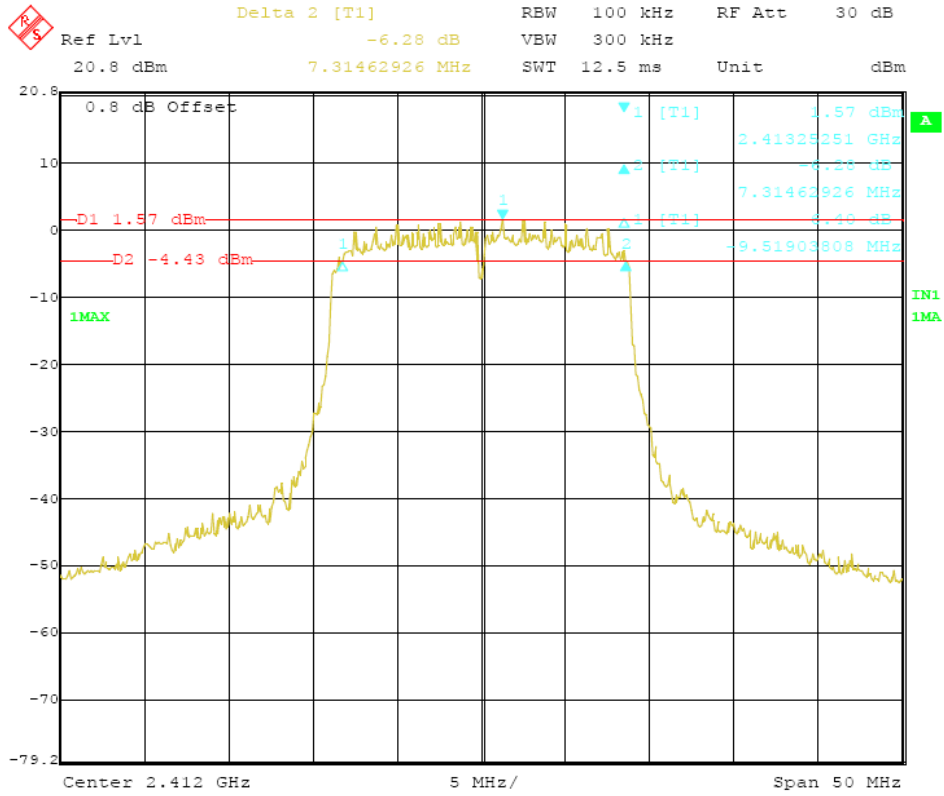

CH1 @ANT 2

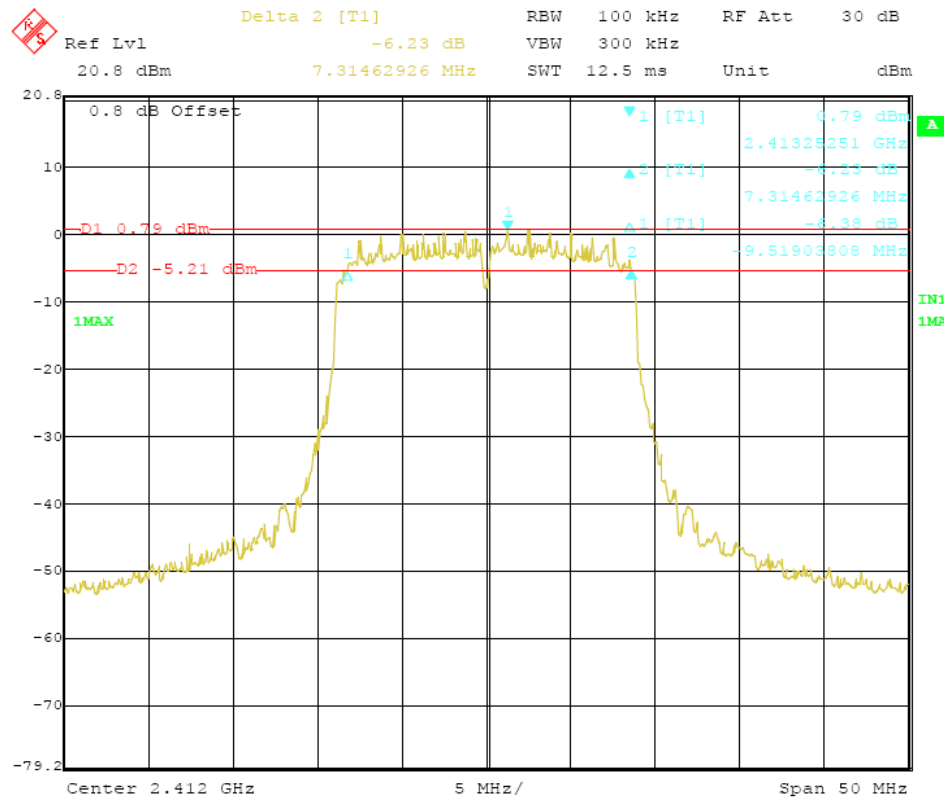

CH6 @ANT 1

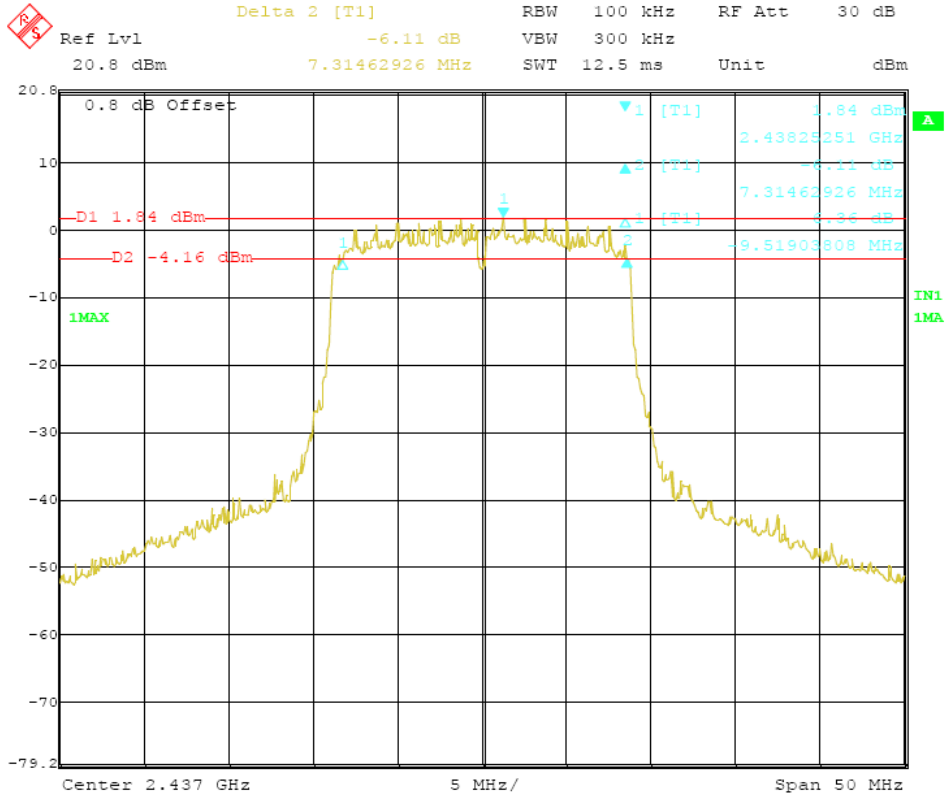

CH6 @ANT 2

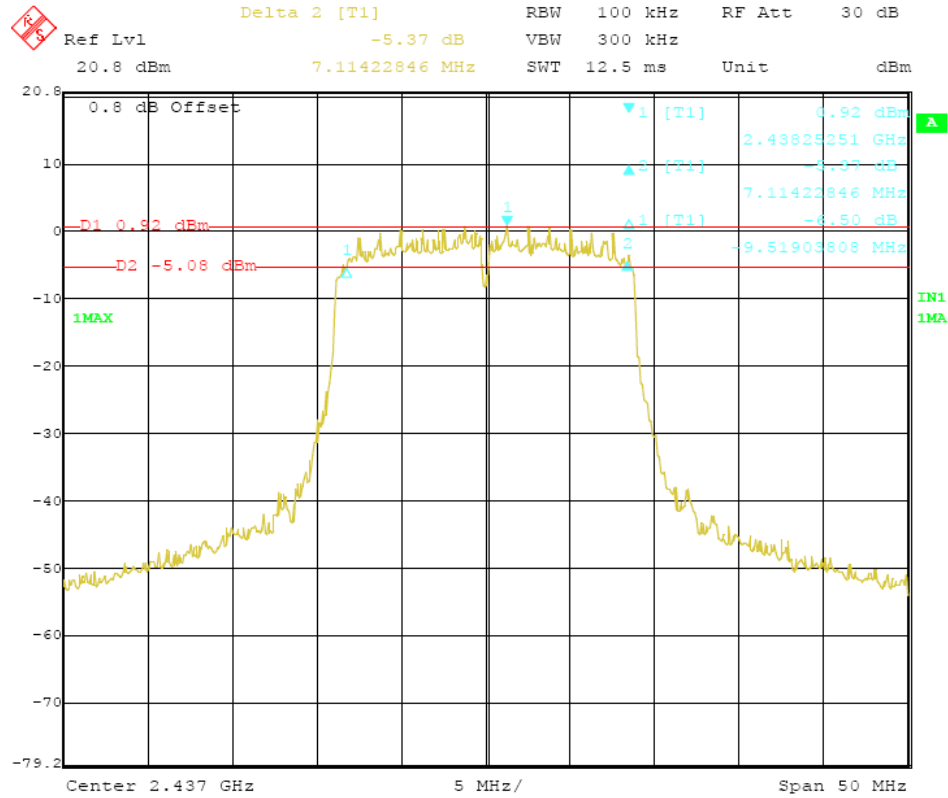

CH11 @ANT 1

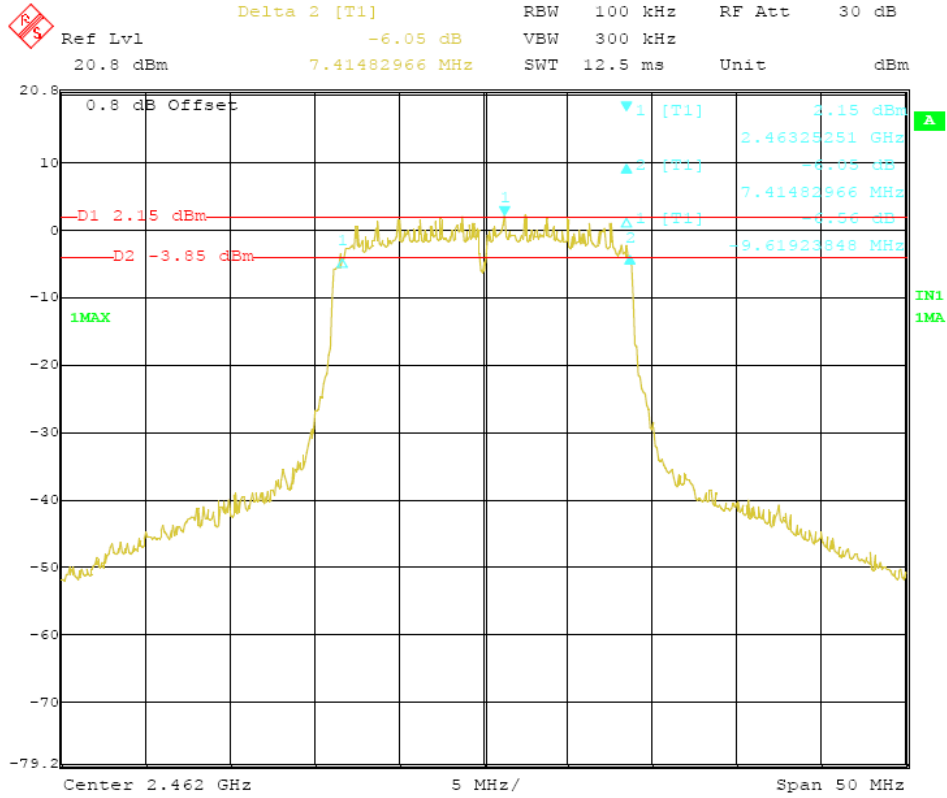

CH11 @ANT 2

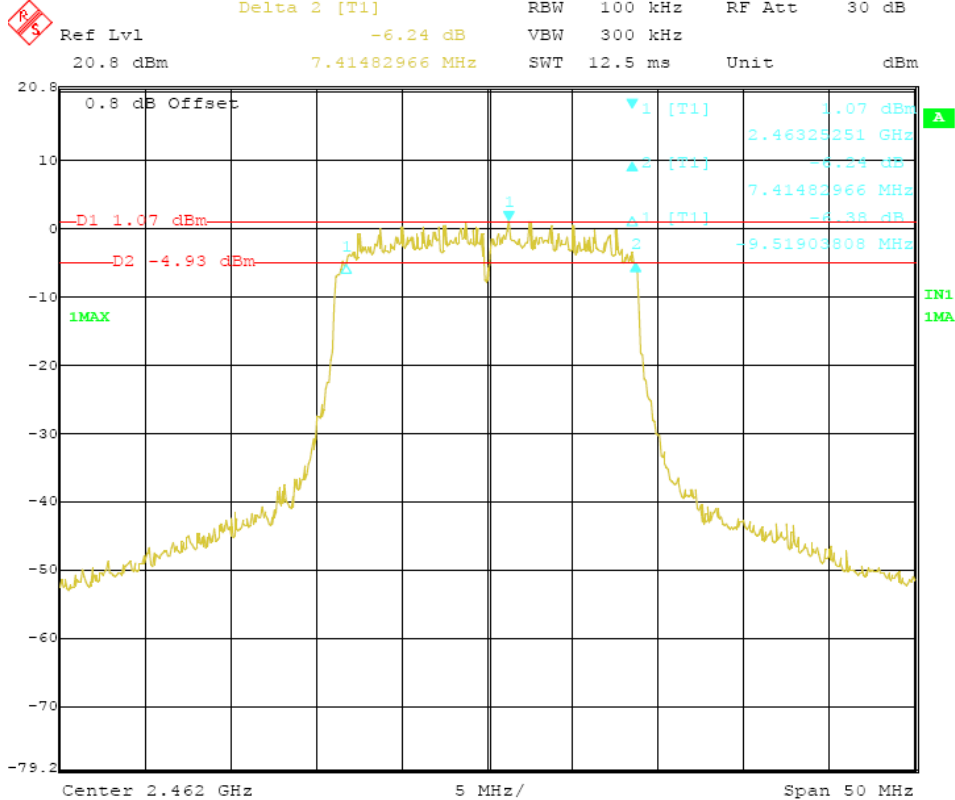

For 802.11n (40MHz) Mode:

CH3 @ANT 1

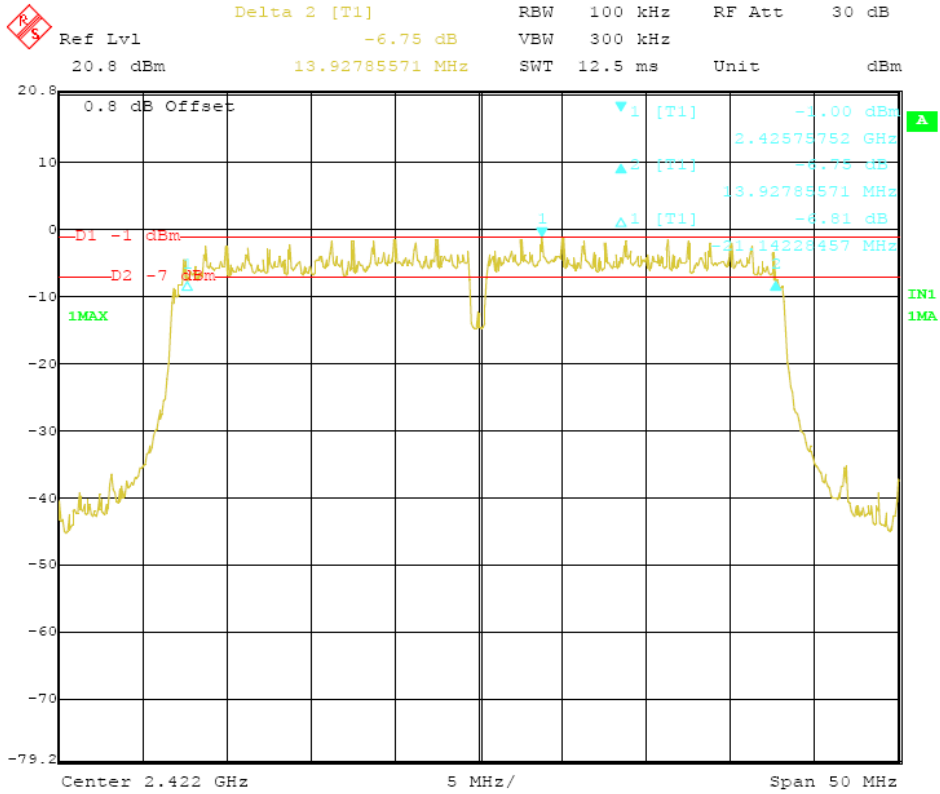

CH3 @ANT 2

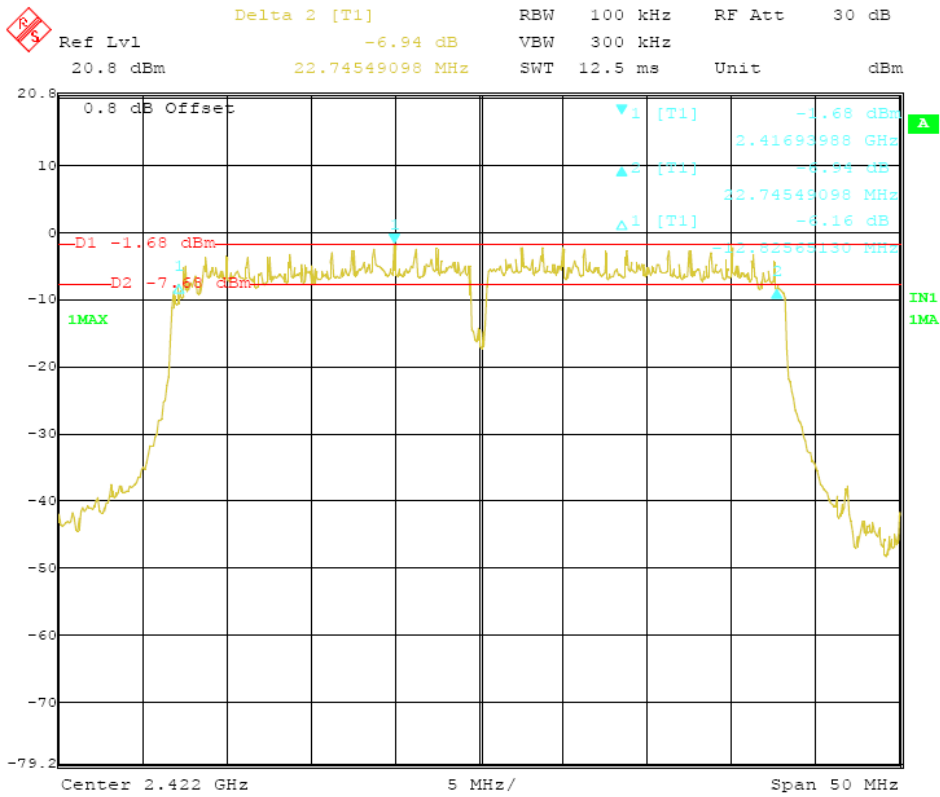

CH6 @ANT 1

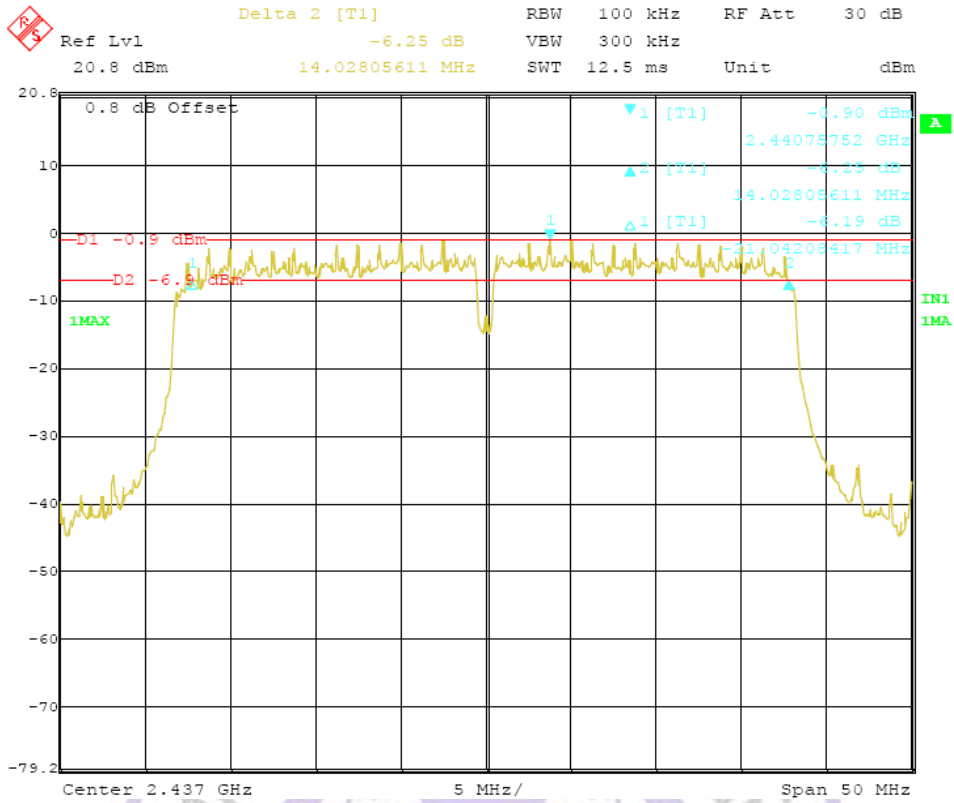

CH6 @ANT 2

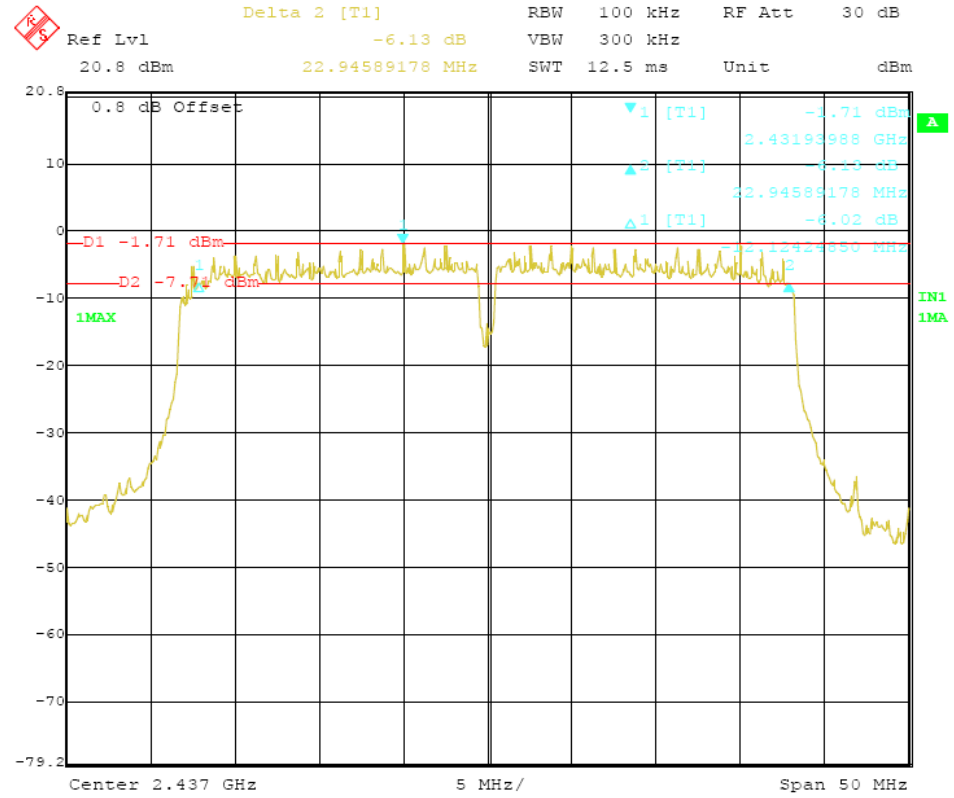

CH9 @ANT 1

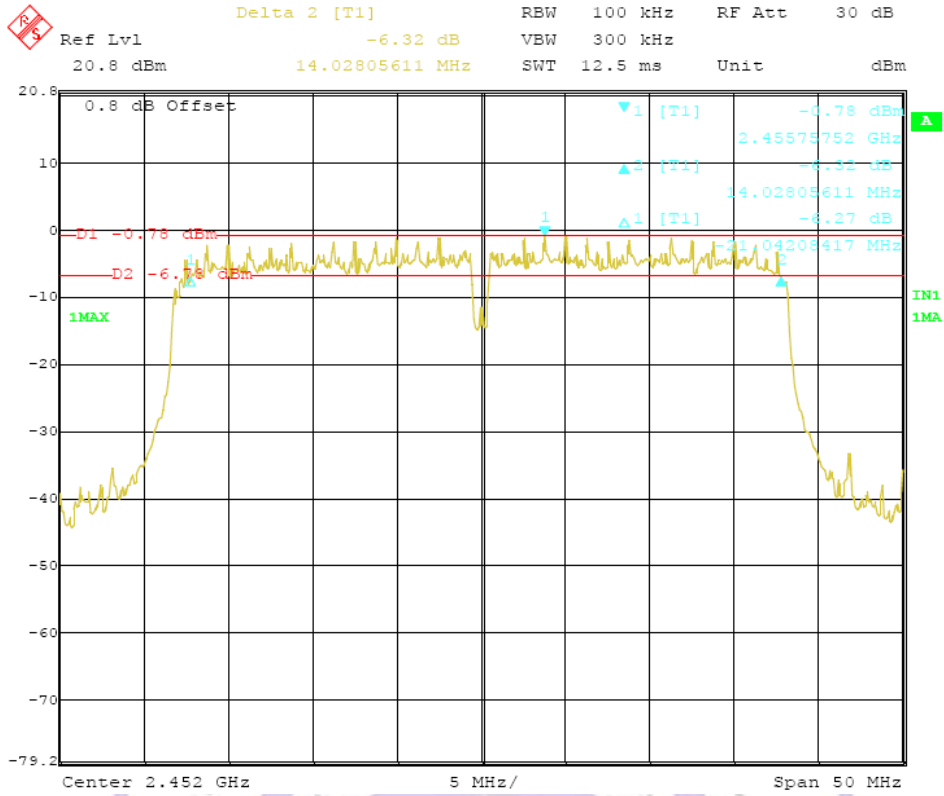

CH9 @ANT 2

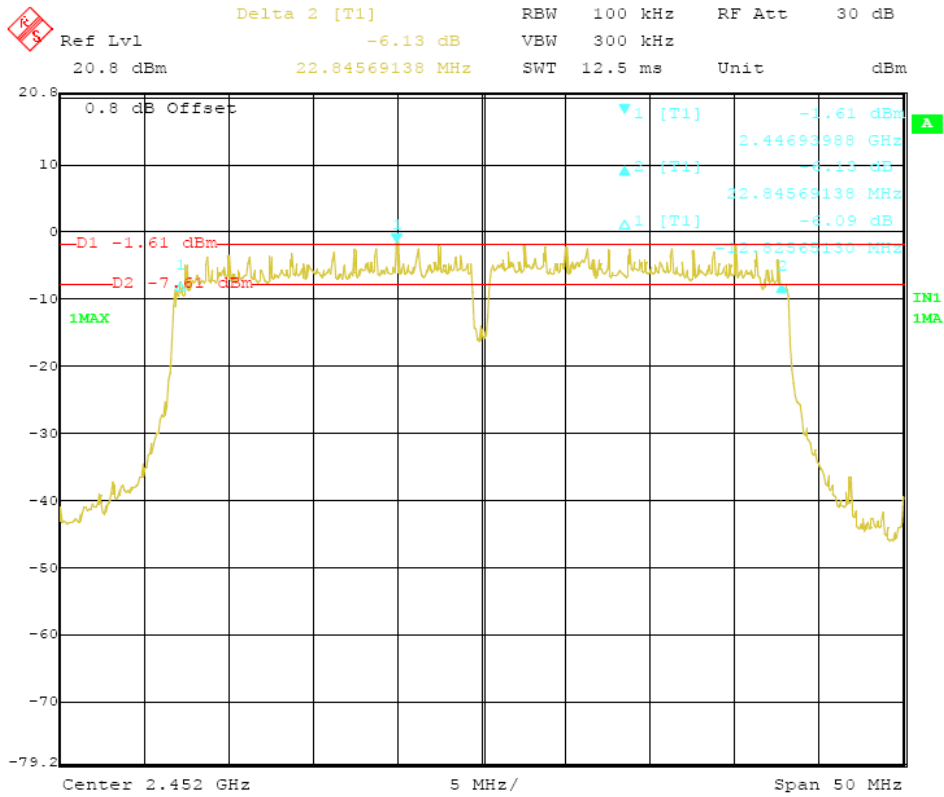

4.4. Maximum Peak Output Power

TEST CONFIGURATION

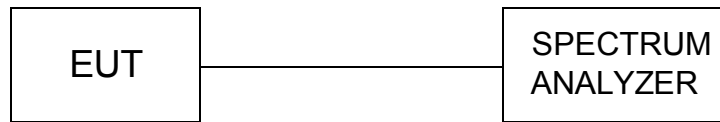

TEST PROCEDURE

According to C63.10 -2009, The EUT was directly connected to the power meter / spectrum analyzer and antenna output port as show in the block diagram as TEST CONFIGURATION shows.

1. For IEEE 802.11b/g and IEEE802.11n HT20 mode, use a PK power meter which's bandwidth is above 26dB bandwidth of signal to measure out each test modes' PK output power.
2. Spectrum analyzer only used for 802.11n HT40 measurement.

LIMIT

The Peak Output Power Measurement limits are 30dBm.

TEST RESULTS

Mode	Channel	Peak Power Output (dBm)			Peak Power Limit (dBm)	PASS / FAIL
		Ant1	Ant 2	Total		
802.11b	1	22.27	22.16	N/A	30	PASS
	6	22.68	22.64	N/A	30	PASS
	11	21.49	21.42	N/A	30	PASS
802.11g	1	21.33	21.48	N/A	30	PASS
	6	22.26	22.25	N/A	30	PASS
	11	20.95	20.68	N/A	30	PASS
802.11n HT20	1	20.44	20.79	23.63	30	PASS
	6	20.65	20.36	23.56	30	PASS
	11	20.41	20.71	23.57	30	PASS
802.11n HT40	3	19.87	19.13	22.53	30	PASS
	6	19.97	19.04	22.54	30	PASS
	9	19.89	19.07	22.51	30	PASS

Note: The test results including the cable lose.

Plots of Maximum Peak Output Power Measurement

For 802.11N Mode(40MHz):

CH3 @ANT 1

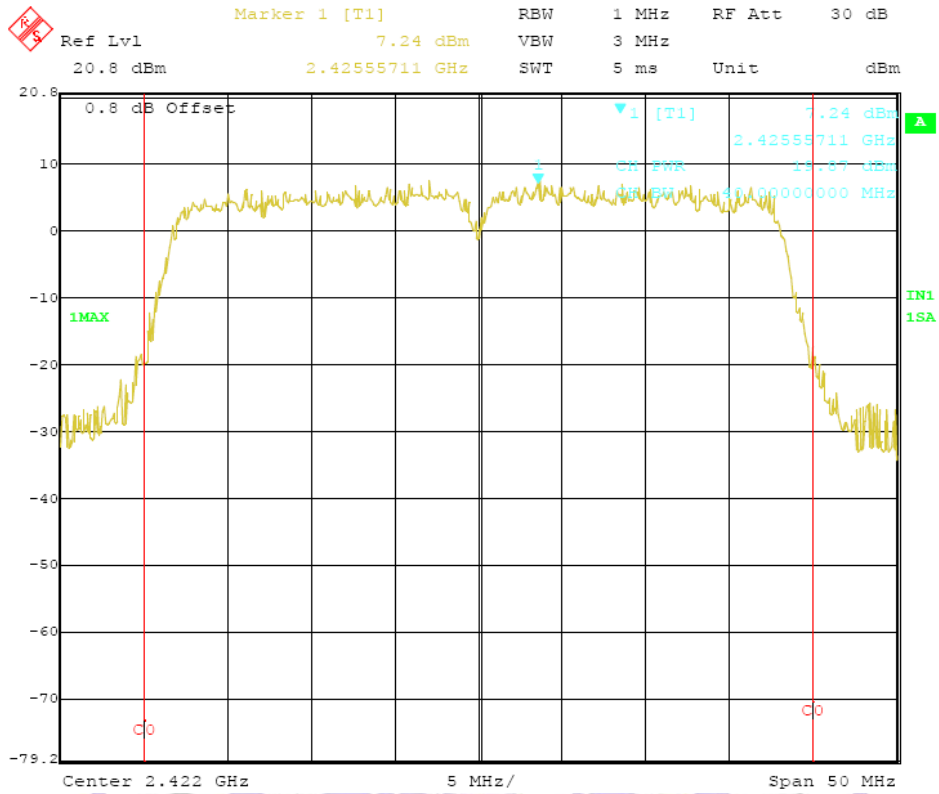

CH3 @ANT 2

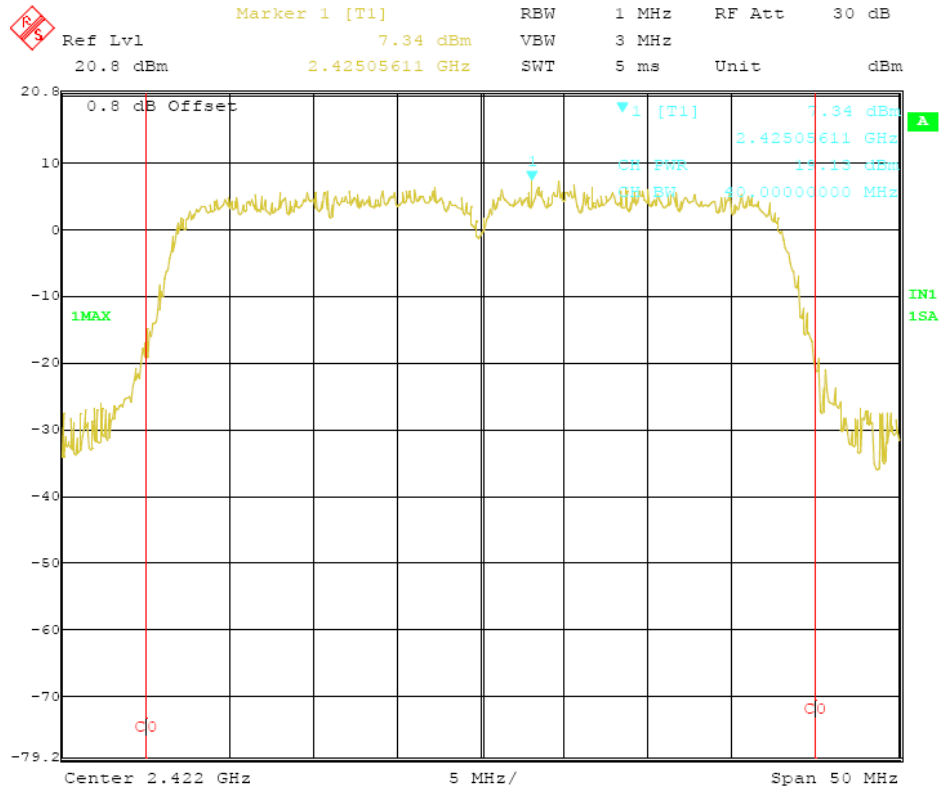

CH6 @ANT 1

Marker 1 [T1] RBW 1 MHz RF Att 30 dB
Ref Lvl 7.36 dBm VBW 3 MHz
20.8 dBm 2.43043687 GHz SWT 5 ms Unit dBm

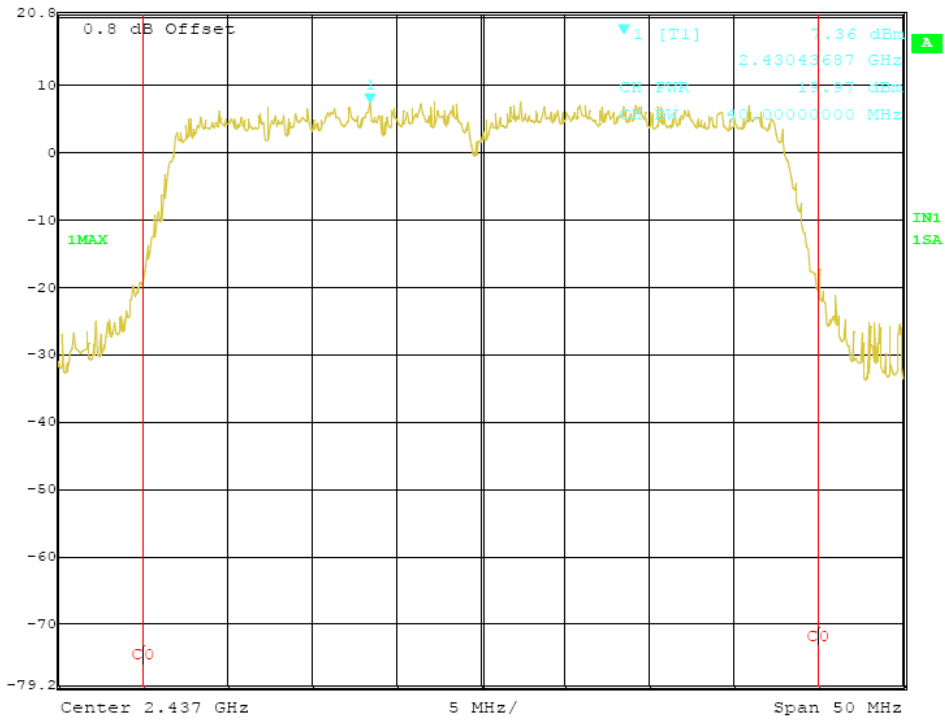

CH6 @ANT 2

Marker 1 [T1] RBW 1 MHz RF Att 30 dB
Ref Lvl 6.49 dBm VBW 3 MHz
20.8 dBm 2.43274148 GHz SWT 5 ms Unit dBm

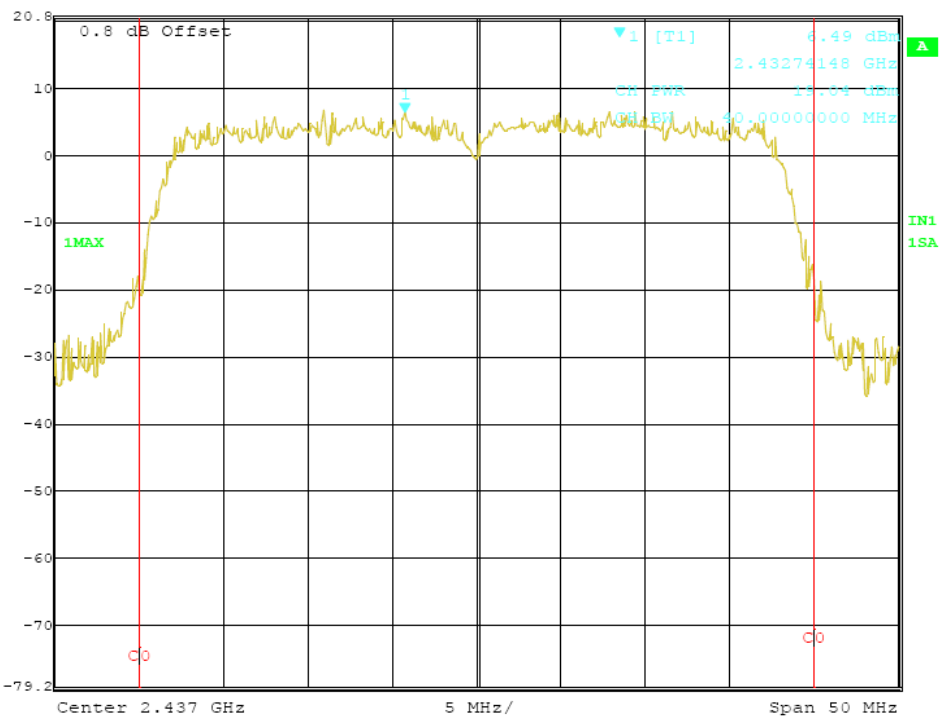

CH9 @ANT 1

Marker 1 [T1] RBW 1 MHz RF Att 30 dB
Ref Lvl 8.11 dBm VBW 3 MHz
20.8 dBm 2.45956513 GHz SWT 5 ms Unit dBm

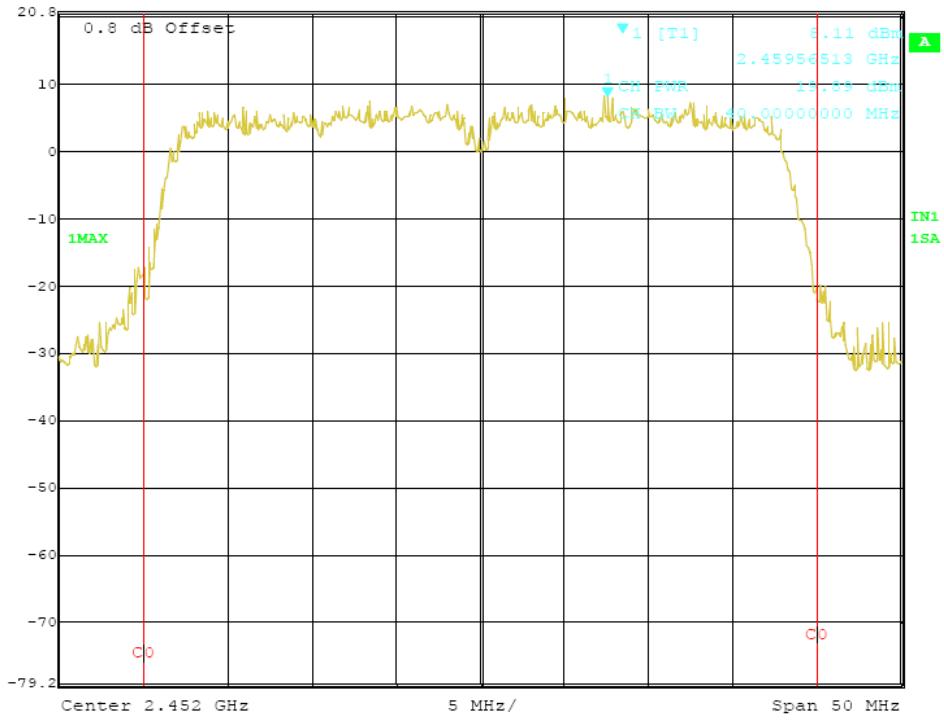

CH9 @ANT 2

Marker 1 [T1] RBW 1 MHz RF Att 30 dB
Ref Lvl 6.95 dBm VBW 3 MHz
20.8 dBm 2.45635872 GHz SWT 5 ms Unit dBm

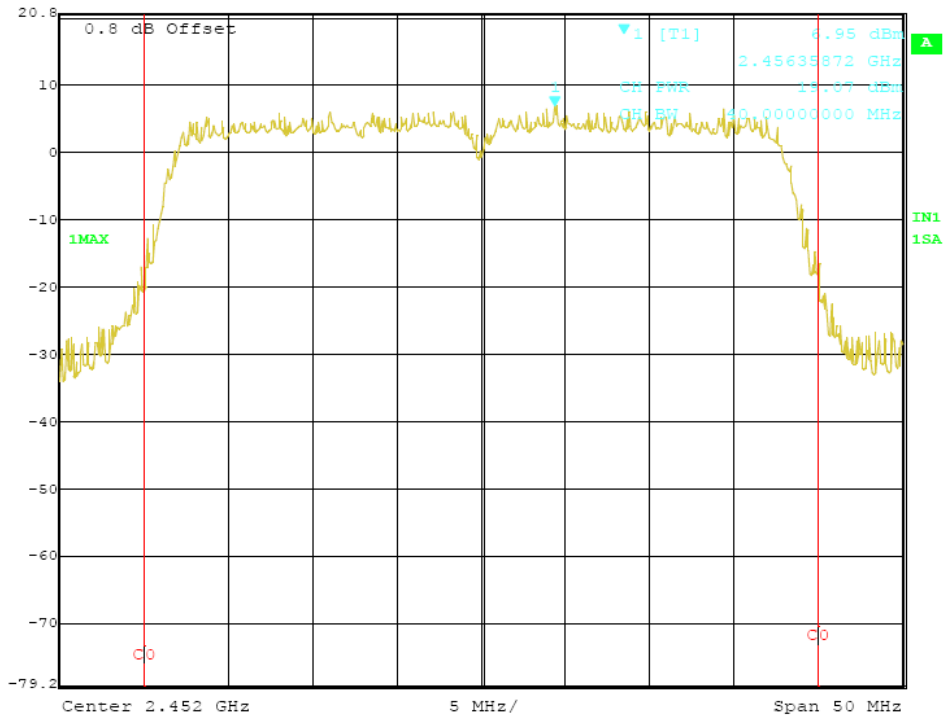

4.5. Band Edge Measurement

TEST CONFIGURATION

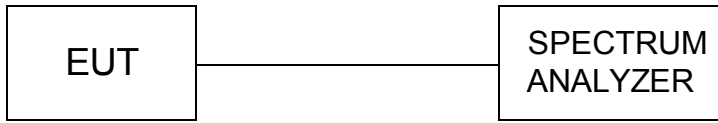

TEST PROCEDURE

The band edge compliance of RF radiated emission should be measured by following the guidance in ANSI C63.4 and FCC KDB Publication No. 558074 (Measurement Guidelines of DTS) with respect to maximizing the emission by rotating the EUT, measuring the emission while the EUT is situated in three orthogonal planes (if appropriate), adjusting the measurement antenna height and polarization etc. Set RBW=100kHz and VBM= 300kHz to measure the peak field strength and set RBW to 1MHz and VBW to 10Hz to measure the average radiated field strength.

The conducted RF band edge was measured by using a spectrum analyzer. Set span wide enough to capture the highest in-band emission and the emission at the band edge. Set RBW and VBW to 100 kHz, to measure the conducted peak band edge.

Connect the spectrum analyzer to the EUT using an appropriate RF cable connected to the EUT output. Configure the spectrum analyzer settings as described below (be sure to enter all losses between the unlicensed wireless device output and the spectrum analyzer).

- Span: Set Span for minimum 50 MHz - Reference Level: 110 dB μ V (corrected for gains and losses of test antenna factor, preamp gain and cable loss) - Attenuation: 10 dB
- Sweep Time: Coupled - Resolution Bandwidth: Up to and including 1 GHz = \geq 100 kHz
- Resolution Bandwidth: Above 1 GHz = 1 MHz - Video Bandwidth: Below 1 GHz = 300 kHz
- Video Bandwidth: Up to and including 1 GHz = \geq 3 MHz for peak and 10 Hz for average
- Detector: Peak

Place a marker at the end of the restricted band closest to the transmit frequency to show compliance. Also measure any emissions in the restricted bands. Save the spectrum analyzer plot. Repeat for each power and modulation for lowest and highest channel.

LIMIT

1. Below -20dB of the highest emission level in operating band.
2. Fall in the restricted bands listed in section 15.205. The maximum permitted average field strength is listed in section 15.209(see Section 15.205(c)).

Frequency (MHz)	Limit Average (dBuV/m)	Limit Peak (dBuV/m)
Below 2390 or Above 2483.5	54	74

TEST RESULTS

Transmitting mode: 802.11b

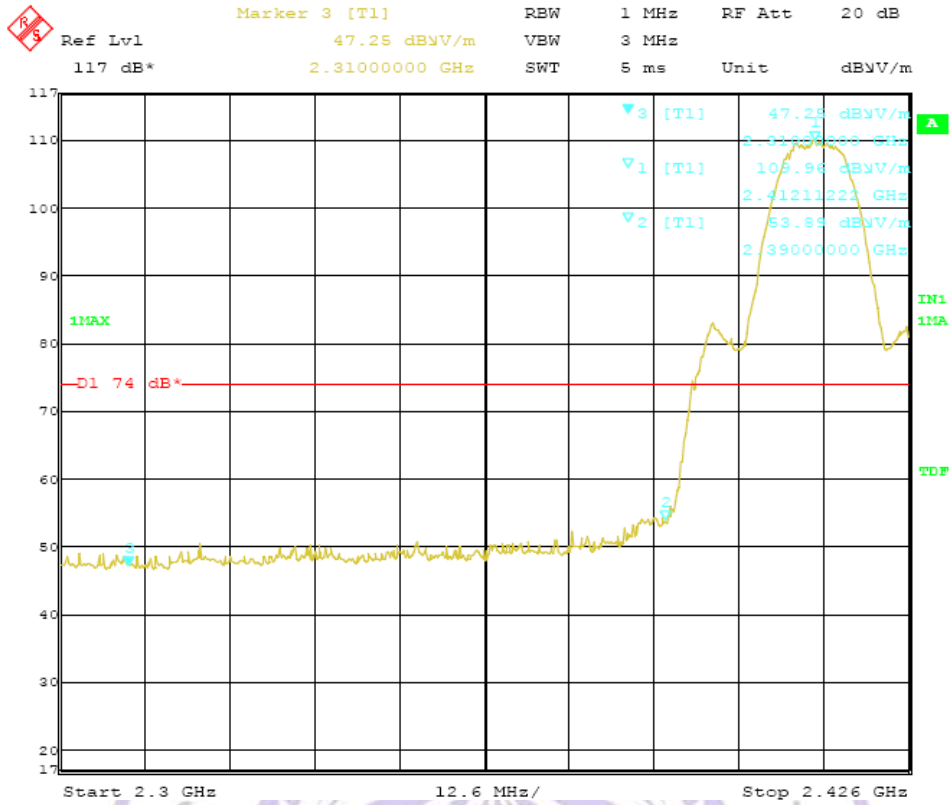

Note:

1. The field strength of any emissions which appear outside of this band shall not exceed the general radiated emission limits in Section 15.209, the peak radiated field strength shall blow 74dBµv/m.
2. Antenna Polarization vertical.

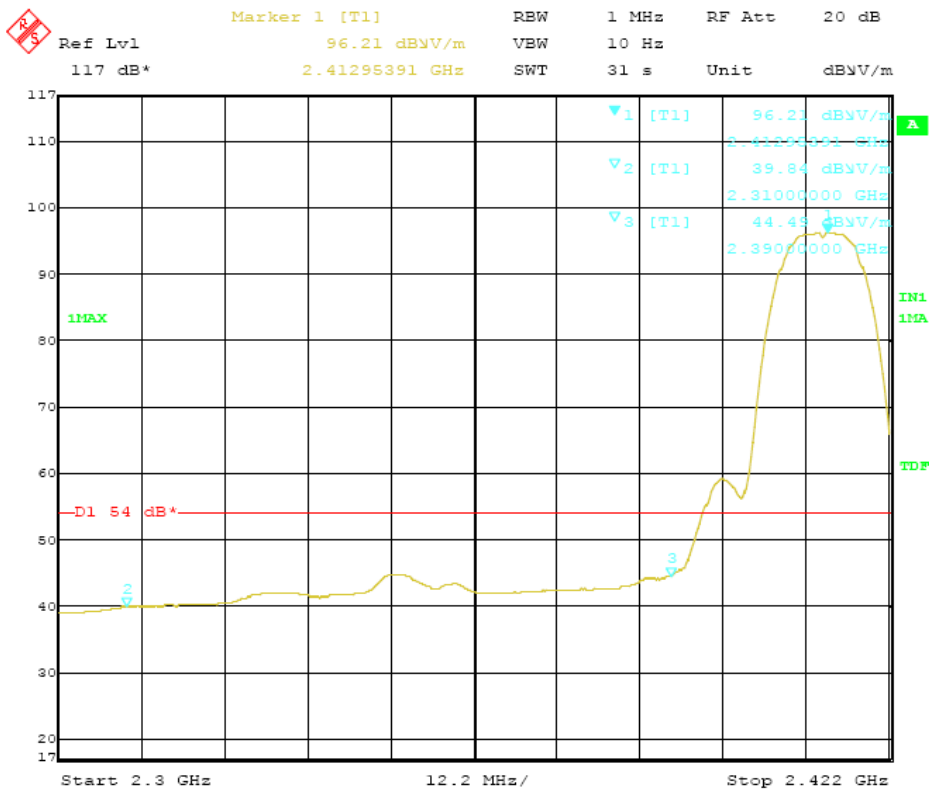

Note:

1. The field strength of any emissions which appear outside of this band shall not exceed the general radiated emission limits in Section 15.209, the average radiated field strength shall blow 54dBµv/m.
2. Antenna Polarization vertical.

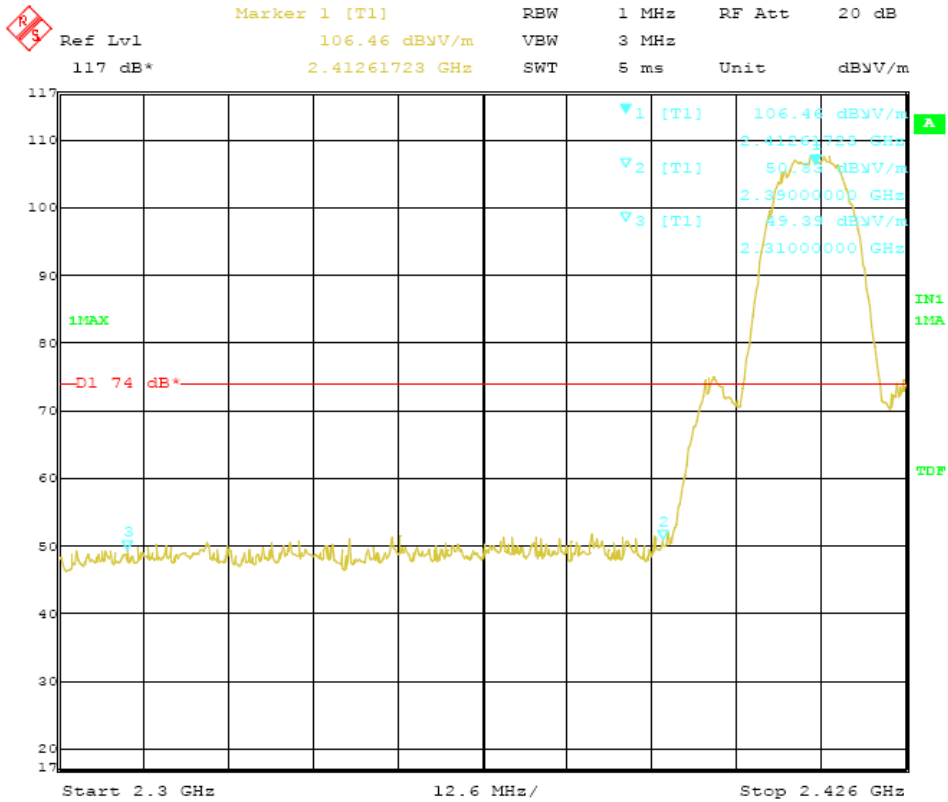

Note:

1. The field strength of any emissions which appear outside of this band shall not exceed the general radiated emission limits in Section 15.209, the peak radiated field strength shall blow 74dB μ v/m.
2. Antenna Polarization horizontal.

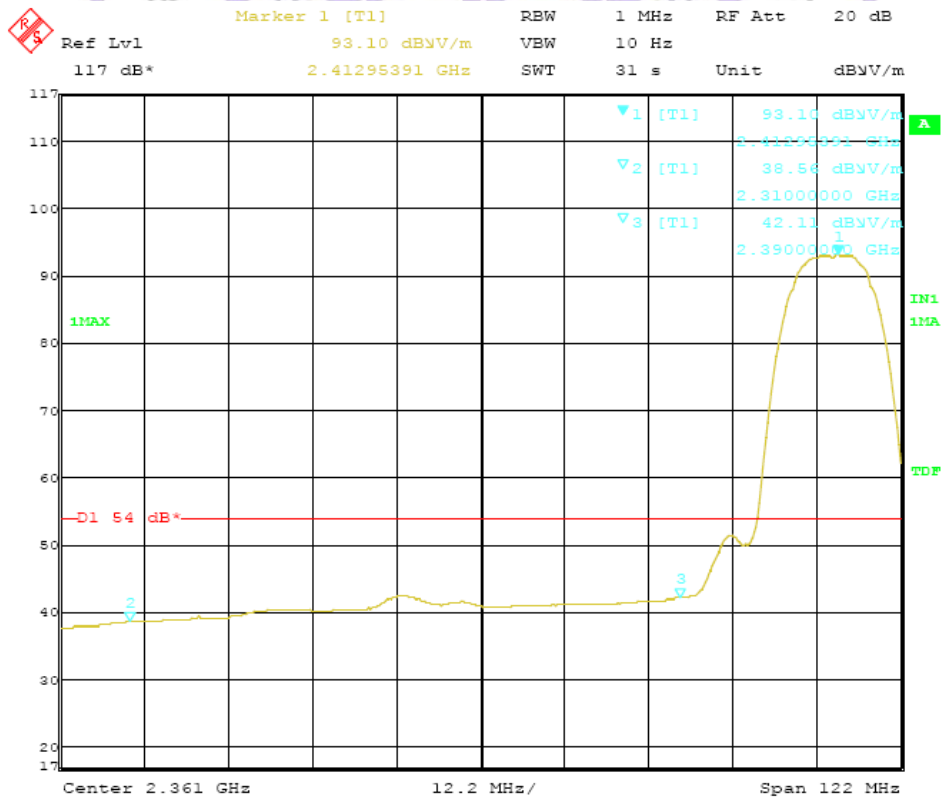

Note:

1. The field strength of any emissions which appear outside of this band shall not exceed the general radiated emission limits in Section 15.209, the average radiated field strength shall blow 54dB μ v/m.
2. Antenna Polarization horizontal.

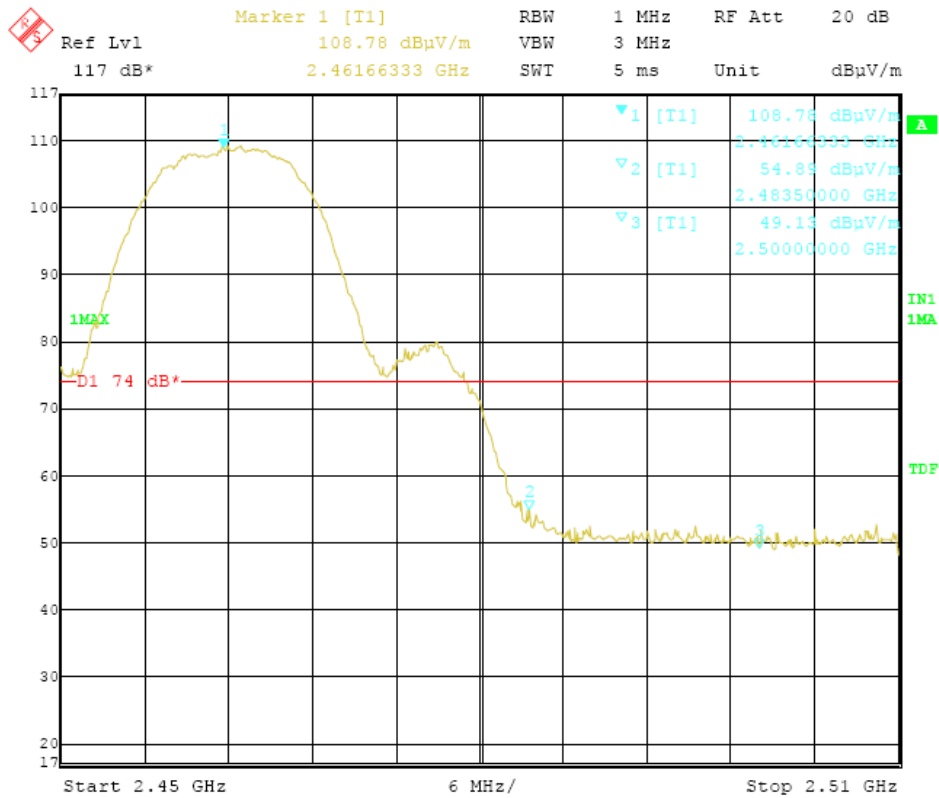

Note:

- 1. The field strength of any emissions which appear outside of this band shall not exceed the general radiated emission limits in Section 15.209, the peak radiated field strength shall blow 74dB μ v/m.
- 2. Antenna Polarization vertical.

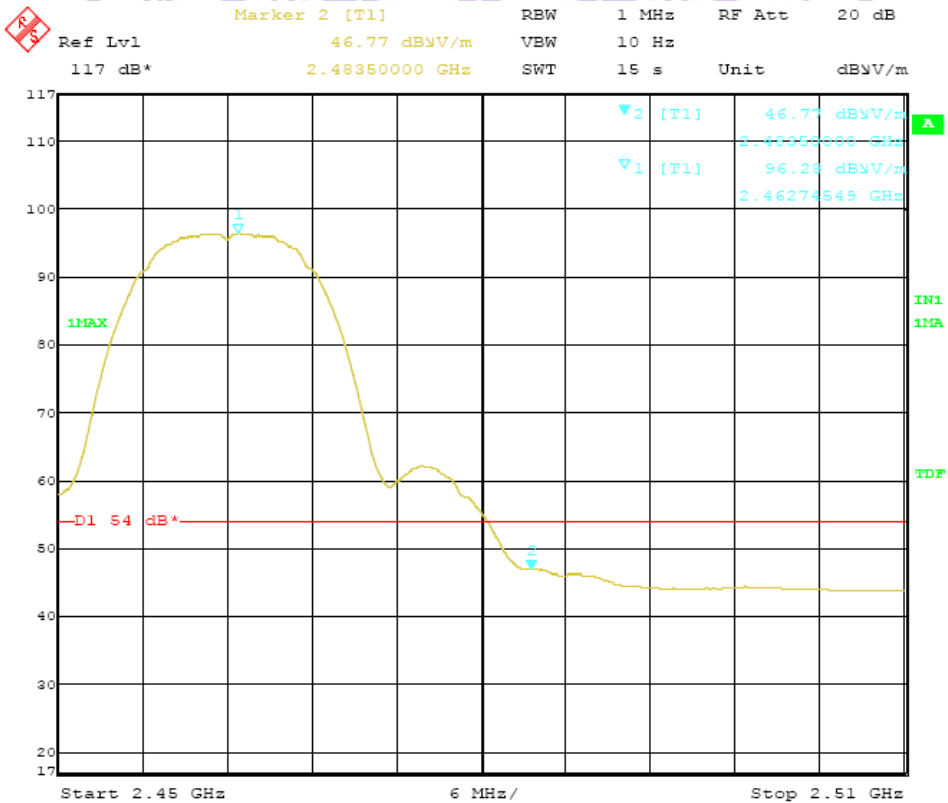

Note:

- 1. The field strength of any emissions which appear outside of this band shall not exceed the general radiated emission limits in Section 15.209, the average radiated field strength shall blow 54dB μ v/m.
- 2. Antenna Polarization vertical.

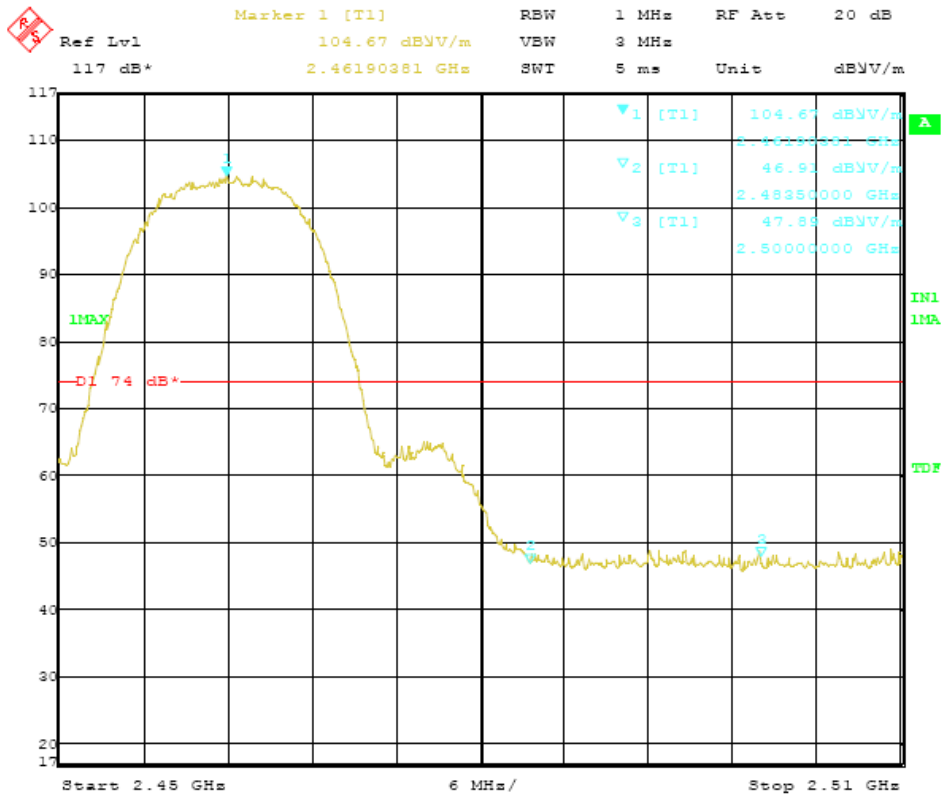

Note:

1. The field strength of any emissions which appear outside of this band shall not exceed the general radiated emission limits in Section 15.209, the peak radiated field strength shall blow 74dB μ v/m.
2. Antenna Polarization horizontal.

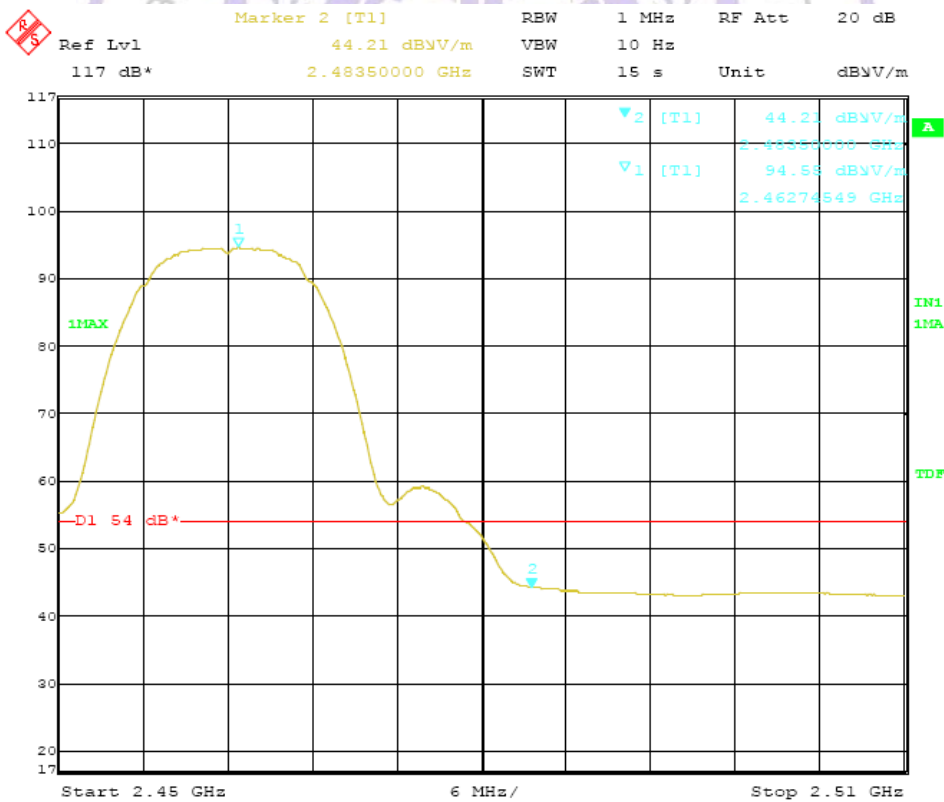

Note:

1. The field strength of any emissions which appear outside of this band shall not exceed the general radiated emission limits in Section 15.209, the average radiated field strength shall blow 54dB μ v/m.
2. Antenna Polarization horizontal.

Note : For 802.11g Mode:

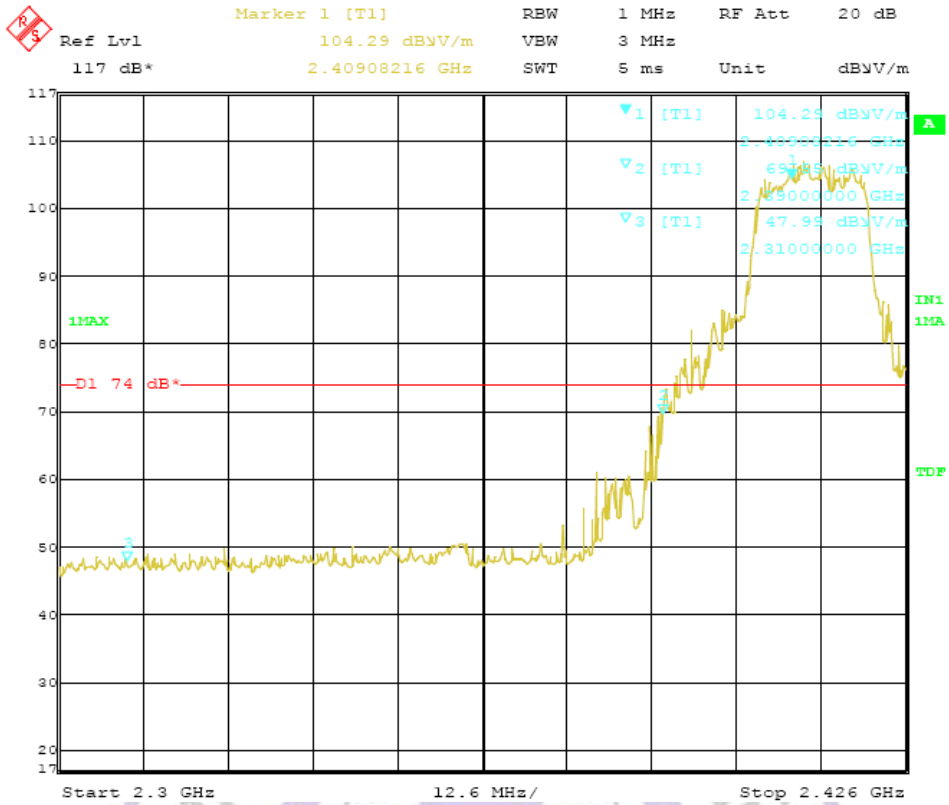

Note:

1. The field strength of any emissions which appear outside of this band shall not exceed the general radiated emission limits in Section 15.209, the peak radiated field strength shall blow 74dB μ v/m.
2. Antenna Polarization vertical.

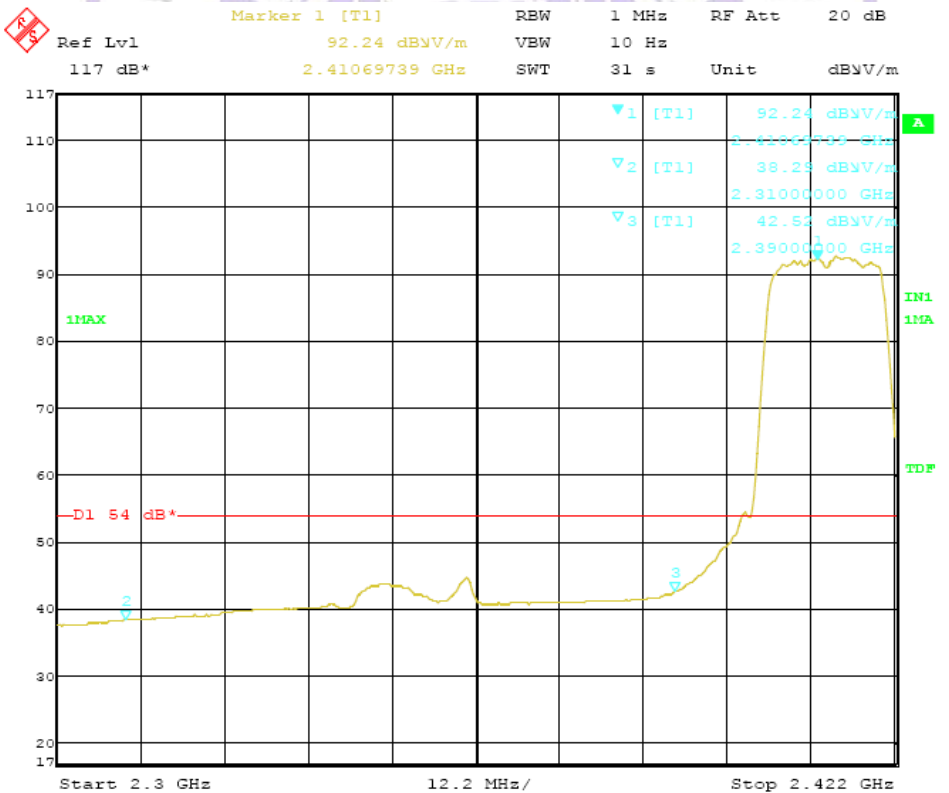

Note:

1. The field strength of any emissions which appear outside of this band shall not exceed the general radiated emission limits in Section 15.209, the average radiated field strength shall blow 54dB μ v/m.
2. Antenna Polarization vertical.

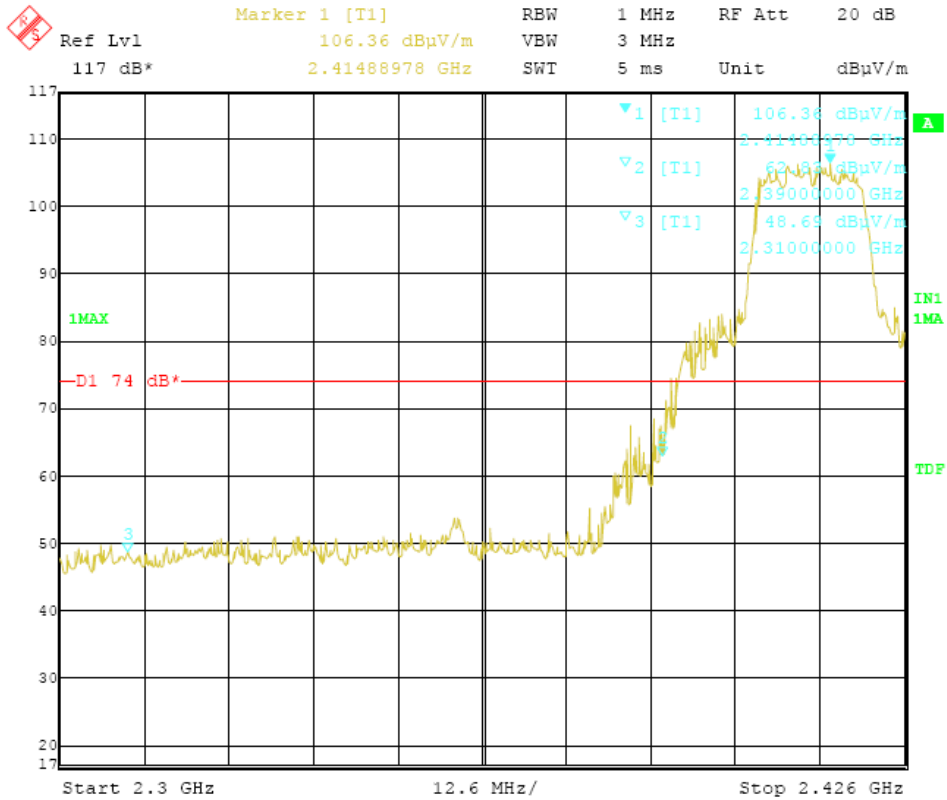

Note:

- 1. The field strength of any emissions which appear outside of this band shall not exceed the general radiated emission limits in Section 15.209, the peak radiated field strength shall blow 74dB μ V/m.
- 2. Antenna Polarization horizontal.

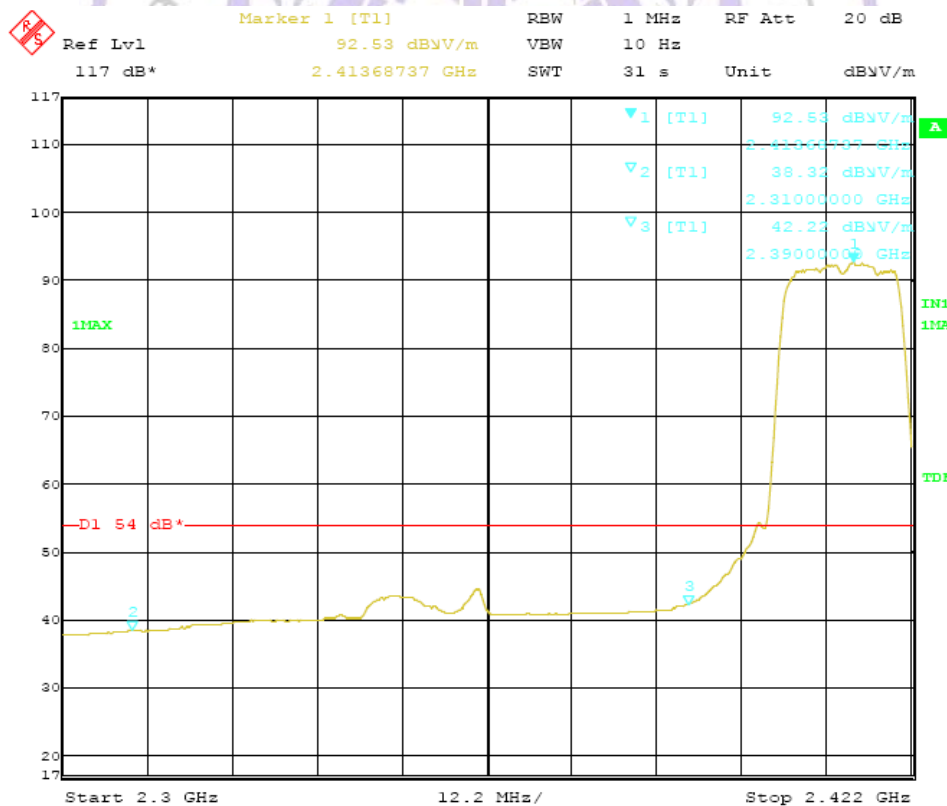

Note:

- 1. The field strength of any emissions which appear outside of this band shall not exceed the general radiated emission limits in Section 15.209, the average radiated field strength shall blow 54dB μ V/m.
- 2. Antenna Polarization horizontal.

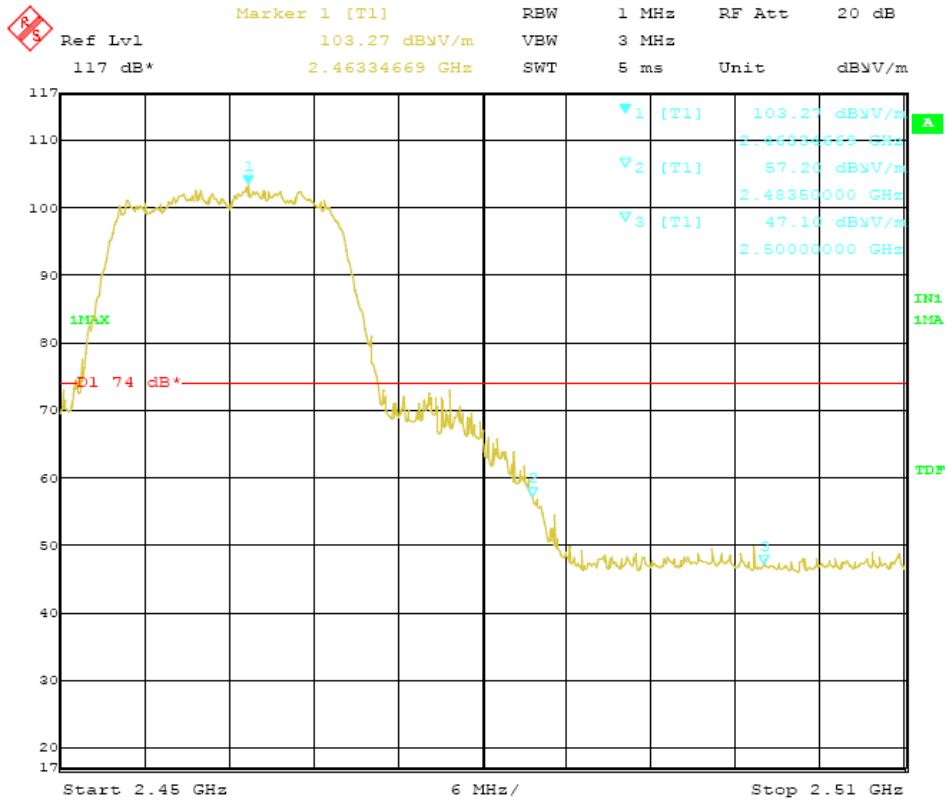

Note:

- 1. The field strength of any emissions which appear outside of this band shall not exceed the general radiated emission limits in Section 15.209, the peak radiated field strength shall blow 74dB μ v/m.
- 2. Antenna Polarization vertical.

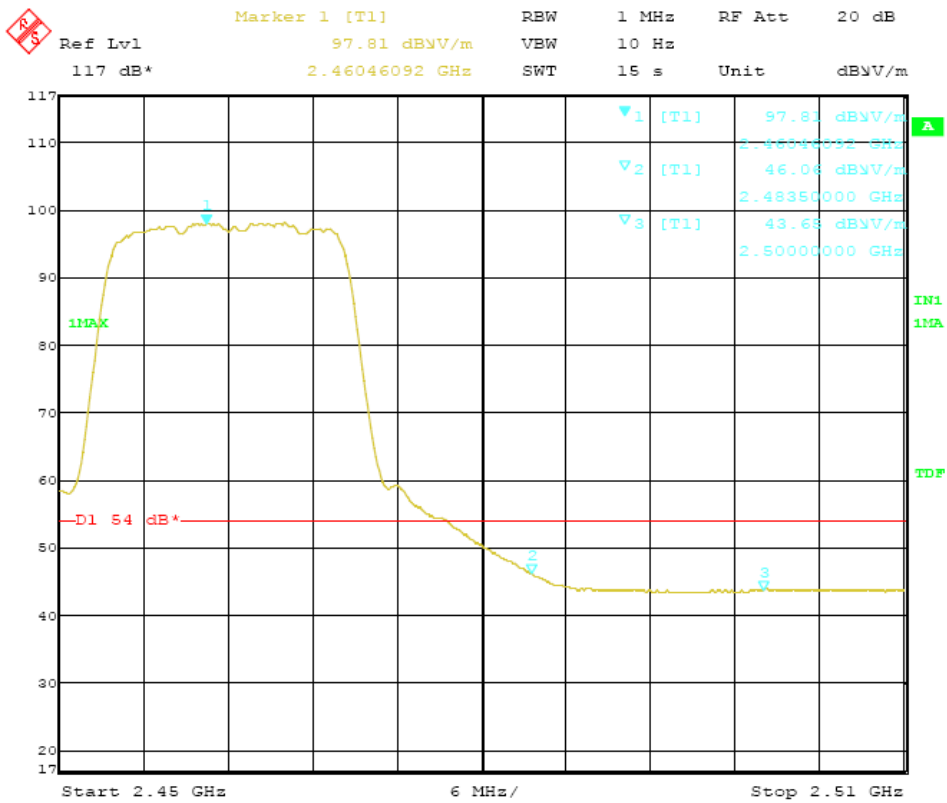

Note:

- 1. The field strength of any emissions which appear outside of this band shall not exceed the general radiated emission limits in Section 15.209, the average radiated field strength shall blow 54dB μ v/m.
- 2. Antenna Polarization vertical.

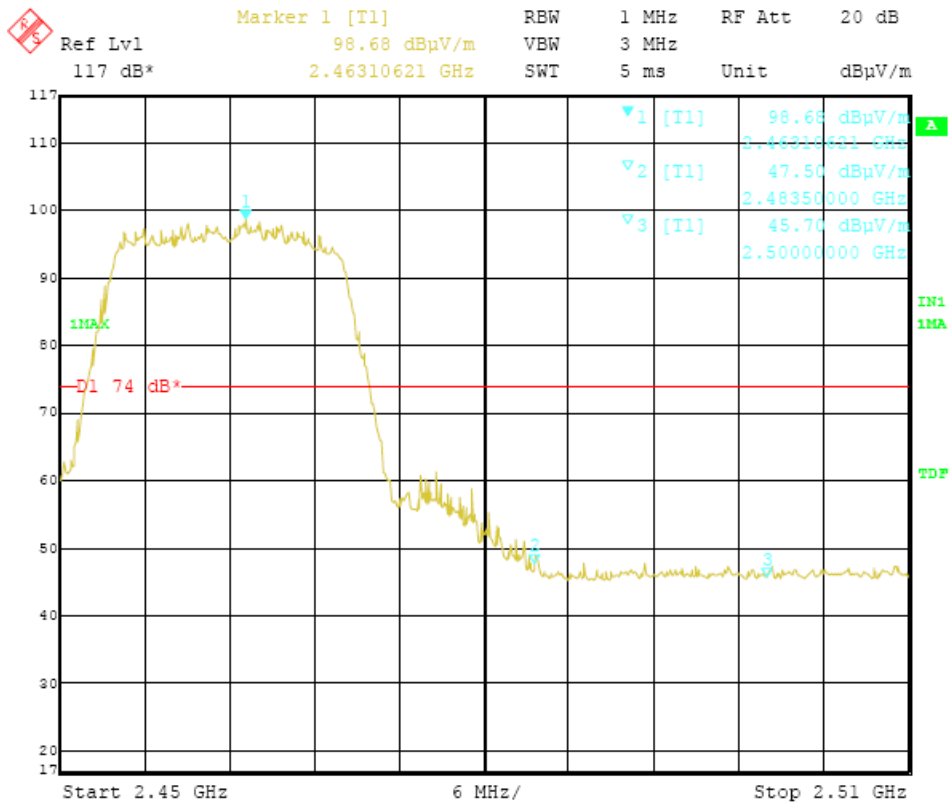

Note:

1. The field strength of any emissions which appear outside of this band shall not exceed the general radiated emission limits in Section 15.209, the peak radiated field strength shall blow 74dBµv/m.
2. Antenna Polarization horizontal.

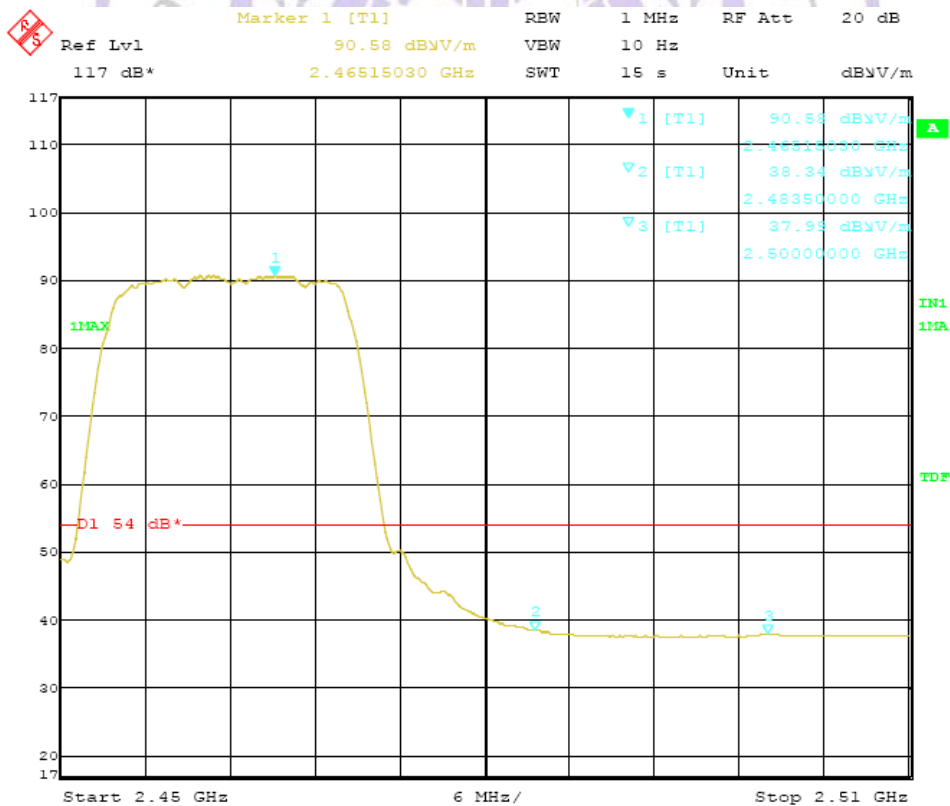

Note:

1. The field strength of any emissions which appear outside of this band shall not exceed the general radiated emission limits in Section 15.209, the average radiated field strength shall blow 54dBµv/m.
2. Antenna Polarization horizontal.

Note : For 802.11n (20MHz) Mode:

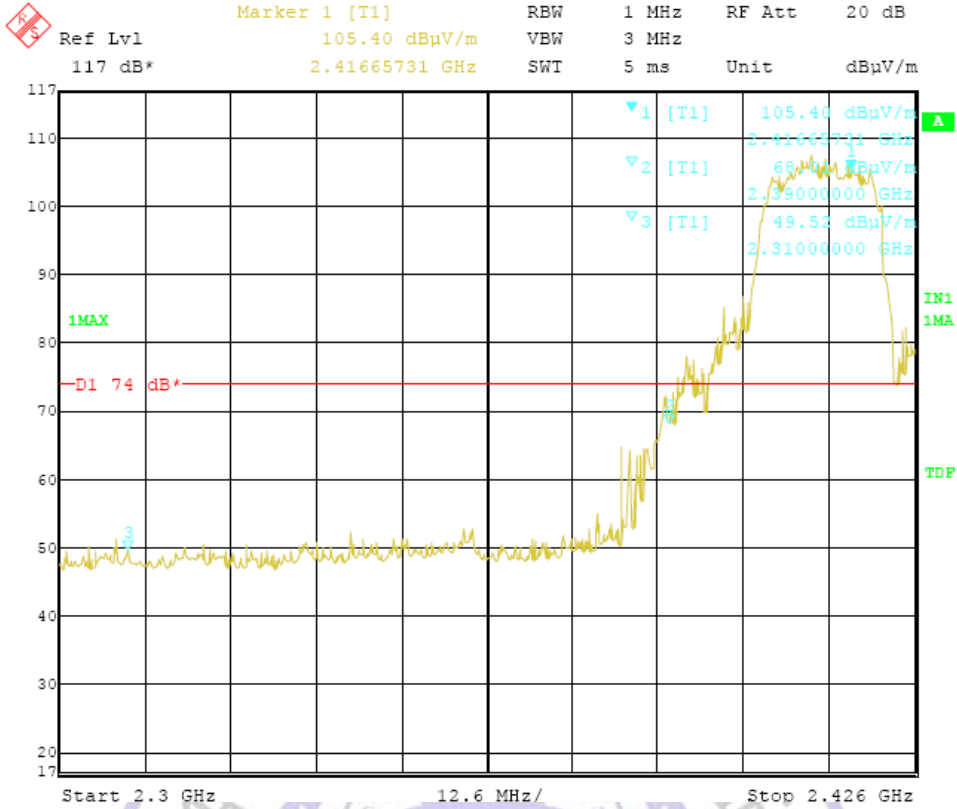

Note:

1. The field strength of any emissions which appear outside of this band shall not exceed the general radiated emission limits in Section 15.209, the peak radiated field strength shall blow 74dB μ v/m.
2. Antenna Polarization vertical.

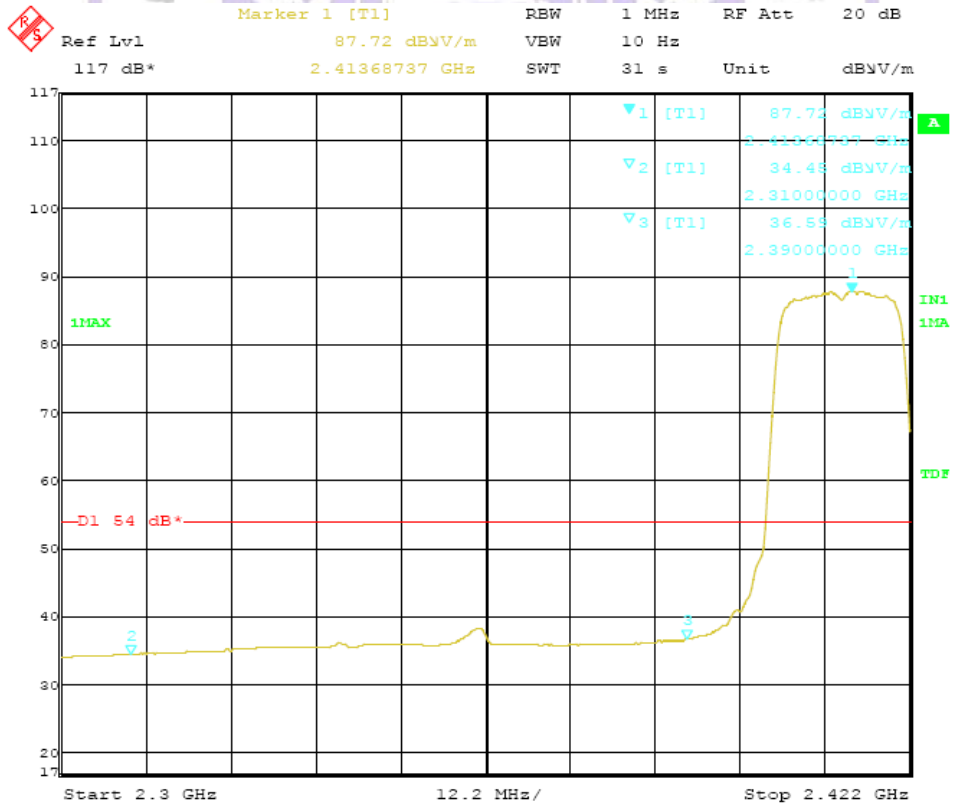

Note:

1. The field strength of any emissions which appear outside of this band shall not exceed the general radiated emission limits in Section 15.209, the average radiated field strength shall blow 54dB μ v/m.
2. Antenna Polarization vertical.

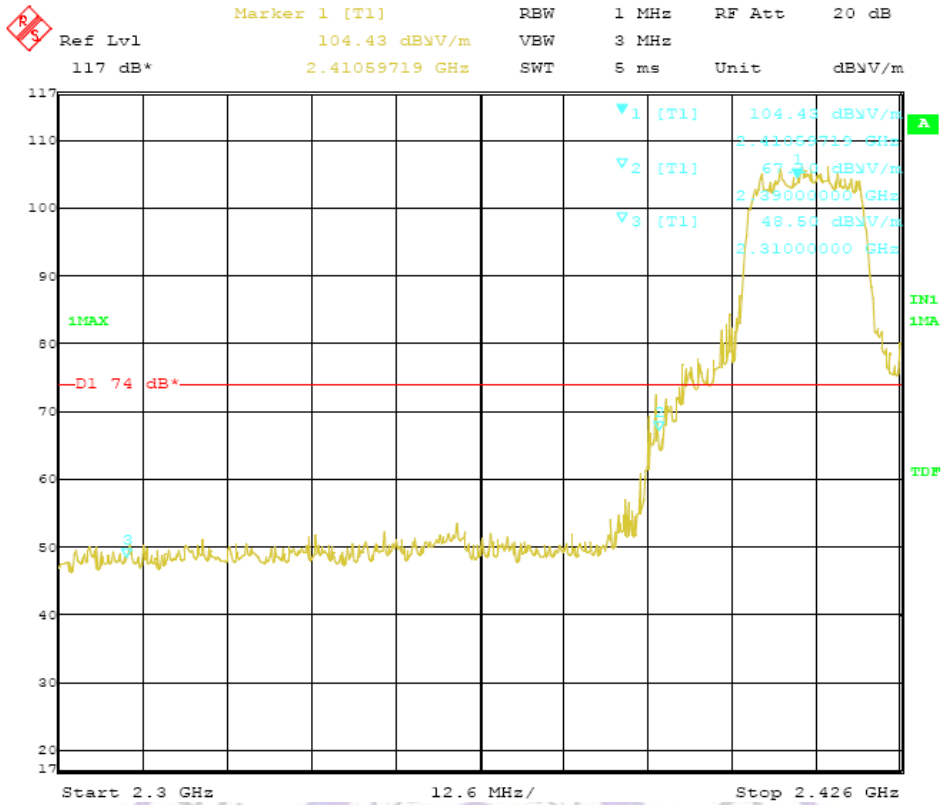

Note:

- 1. The field strength of any emissions which appear outside of this band shall not exceed the general radiated emission limits in Section 15.209, the peak radiated field strength shall blow 74dB μ v/m.
- 2. Antenna Polarization horizontal.

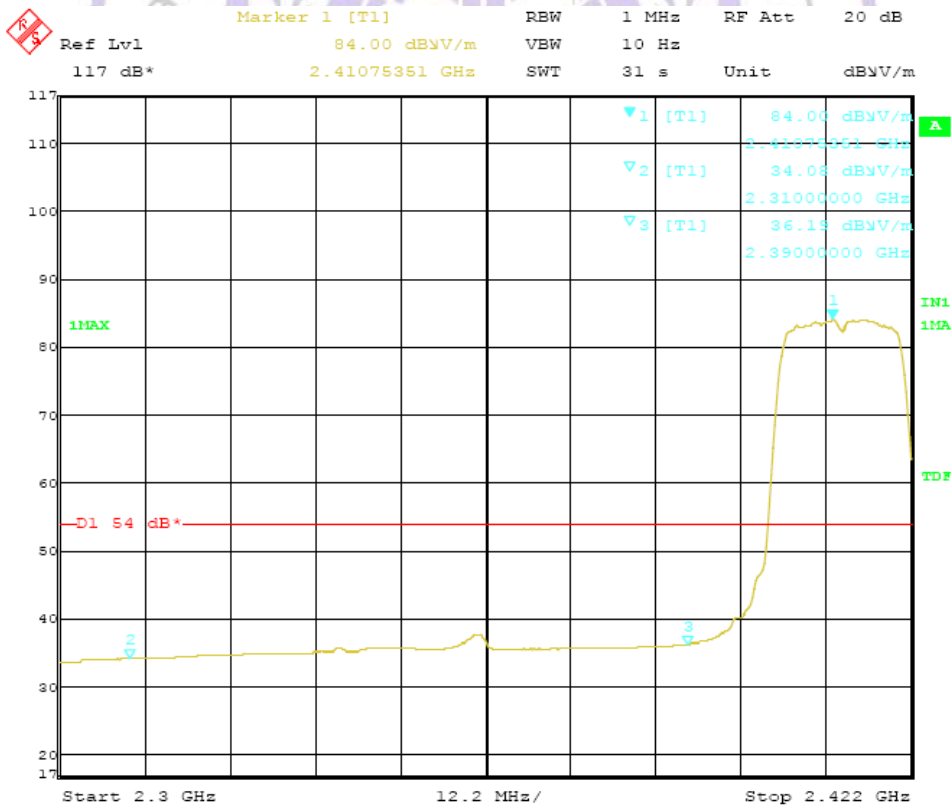

Note:

- 1. The field strength of any emissions which appear outside of this band shall not exceed the general radiated emission limits in Section 15.209, the average radiated field strength shall blow 54dB μ v/m.
- 2. Antenna Polarization horizontal.

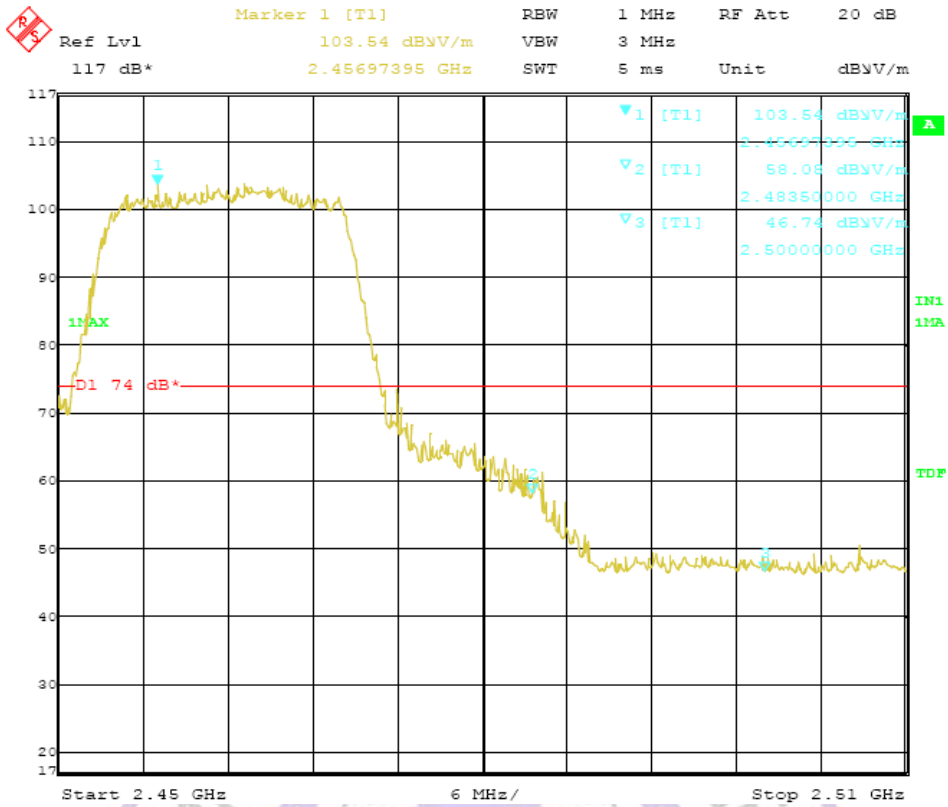

Note:

- 1. The field strength of any emissions which appear outside of this band shall not exceed the general radiated emission limits in Section 15.209, the peak radiated field strength shall blow 74dB μ v/m.
- 2. Antenna Polarization vertical.

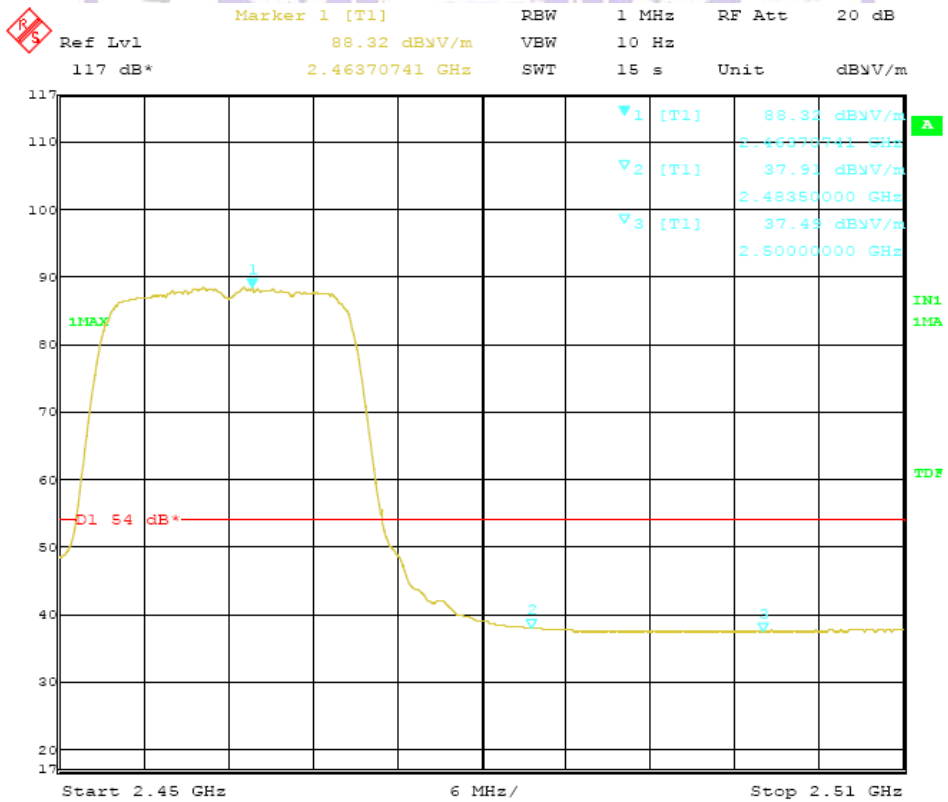

Note:

- 1. The field strength of any emissions which appear outside of this band shall not exceed the general radiated emission limits in Section 15.209, the average radiated field strength shall blow 54dB μ v/m.
- 2. Antenna Polarization vertical.

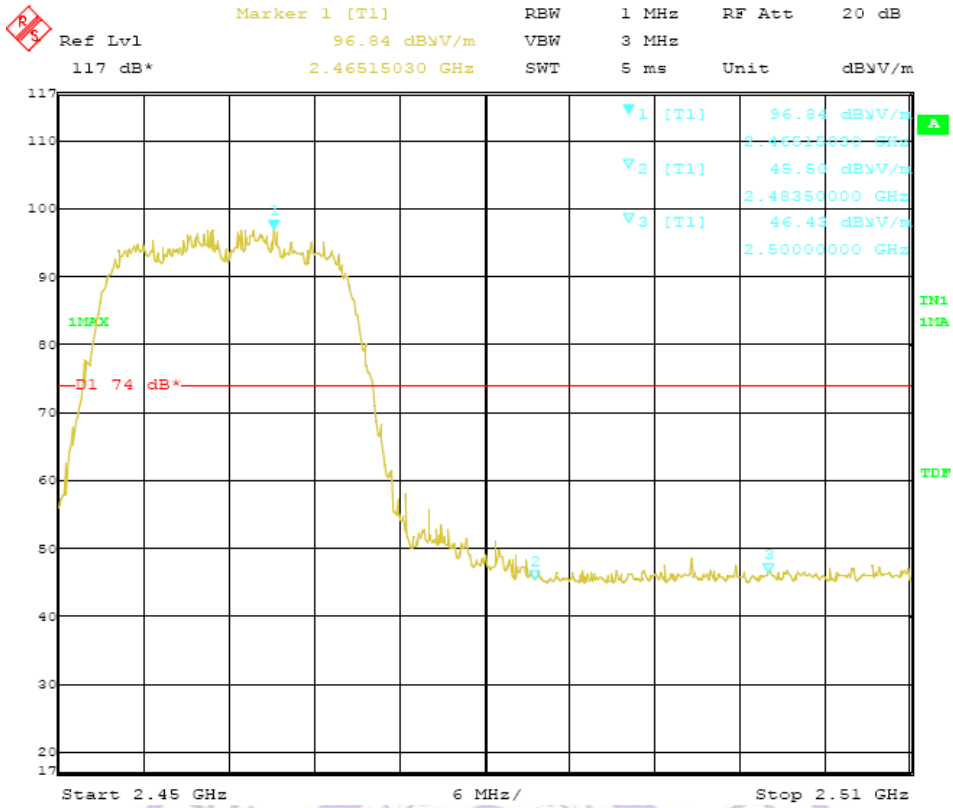

Note:

- 1. The field strength of any emissions which appear outside of this band shall not exceed the general radiated emission limits in Section 15.209, the peak radiated field strength shall blow 74dB μ V/m.
- 2. Antenna Polarization horizontal.

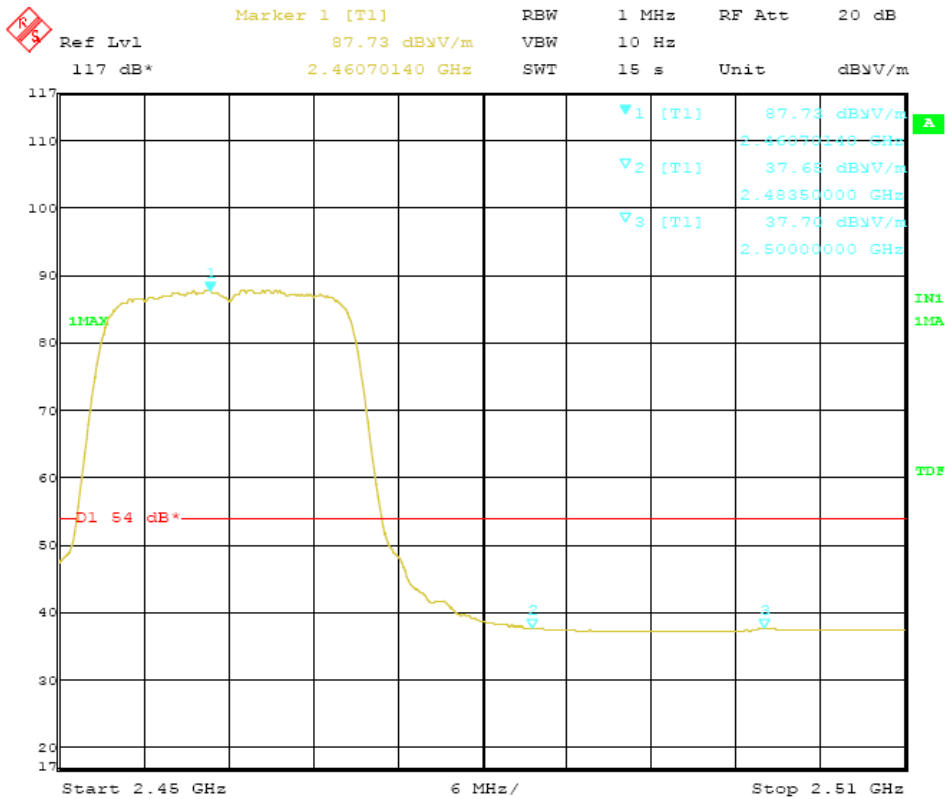

Note:

- 1. The field strength of any emissions which appear outside of this band shall not exceed the general radiated emission limits in Section 15.209, the average radiated field strength shall blow 54dB μ V/m.
- 2. Antenna Polarization horizontal.