



FCC RADIO TEST REPORT

Applicant : Heat Factory USA, Inc.
Address : 2793 Loker Ave W Carlsbad, CA 92010
Equipment : Heated Insole Standard Remote
Model No. : 1470RC
Trade Name : Heat Factory
FCC ID. : ZAM-1470RM

I HEREBY CERTIFY THAT :

The sample was received on Oct. 19, 2017 and the testing was carried out on Oct. 26, 2017 at CerpPASS Technology Corp. The test result refers exclusively to the test presented test model / sample. Without written approval of CerpPASS Technology Corp., the test report shall not be reproduced except in full.

Approved by:

Mark Liao / Assistant Manager

Tested by:

Spree Yei / Engineer

Laboratory Accreditation:

CerpPASS Technology Corporation Test Laboratory





Contents

- 1. **Summary of Test Procedure and Test Results.....4**
 - 1.1 Applicable Standards4
- 2. **Test Configuration of Equipment under Test.....5**
 - 2.1 Feature of Equipment under Test.....5
 - 2.2 Test Mode and Test Software5
 - 2.3 Description of Test System.....5
 - 2.4 General Information of Test.....6
 - 2.5 Measurement Uncertainty6
- 3. **Test Equipment and Ancillaries Used for Tests7**
- 4. **Antenna Requirements.....8**
 - 4.1 Antenna Construction and Directional Gain.....8
- 5. **Test of Conducted Emission.....9**
 - 5.1 Test Limit9
 - 5.2 Test Procedures9
 - 5.3 Typical Test Setup10
 - 5.4 Test Result and Data10
- 6. **Test of Radiated Emission11**
 - 6.1 Test Limit11
 - 6.2 Test Procedures12
 - 6.3 Typical Test Setup15
 - 6.4 Test Result and Data16
 - 6.5 Test Photographs (30MHz~1GHz)24
 - 6.6 Test Photographs (Above 1GHz)25
- 7. **99% Occupied Bandwidth Measurement.....26**
 - 7.1 Test Procedure26
 - 7.2 Test Setup Layout26
 - 7.3 Limits of Band Edges Measurement26
 - 7.4 Test Result and Data27
- 8. **Transmission Time Control.....28**
 - 8.1 Test Procedure28
 - 8.2 Test Setup Layout28
 - 8.3 Test Limit28
 - 8.4 Test Result and Data29



History of this test report

Report No.	Issue Date	Description
TEFL1810071	Oct. 22, 2018	Original



1. Summary of Test Procedure and Test Results

1.1 Applicable Standards

ANSI C63.4:2014

ANSI C63.10:2013

FCC Rules and Regulations Part 15 Subpart C §15.231

FCC Rule	Test Type	Result
15.203	Antenna Requirement	Pass
15.209 15.231	Radiated Emission	Pass
15.231	20dB Occupied Bandwidth Measurement	Pass
15.231	Transmission Time Control	Pass

This EUT has been also tested and complied with the requirement of FCC Part 15, Subpart B, recorded in a separate test report (TEFB1710028).



2. Test Configuration of Equipment under Test

2.1 Feature of Equipment under Test

Frequency Range	433.92MHz
Rating	2.7-3.2V
Antenna Type	PCB Antenna

2.2 Test Mode and Test Software

- a. During testing, the interface cables and equipment positions were varied according to ANSI C63.4.
- b. The complete test system included EUT for the test.

2.3 Description of Test System

The EUT was tested alone. No support devices are needed for testing.



2.4 General Information of Test

Test Site	CerpPASS Technology Corporation Test Laboratory Address: No.10, Ln. 2, Lianfu St., Luzhu Dist., Taoyuan City 33848, Taiwan (R.O.C.) Tel:+886-3-3226-888 Fax:+886-3-3226-881 Address: No.68-1, Shihbachongsi, Shihding Township, New Taipei City 223, Taiwan, R.O.C. Tel: +886-2-2663-8582	
	FCC	TW1079, TW1061, 390316, 228391, 641184
	IC	4934E-1, 4934E-2
	VCCI	T-2205 for Telecommunication Test C-4663 for Conducted emission test R-4218, R-4399 for Radiated emission test G-10812, G-10813 for radiated disturbance above 1GHz
Frequency Range Investigated:	Conducted: from 150kHz to 30 MHz Radiation: from 30 MHz to 5,000MHz	
Test Distance:	The test distance of radiated emission from antenna to EUT is 3 M.	

2.5 Measurement Uncertainty

Measurement Item	Measurement Frequency	Polarization	Uncertainty
Conducted Emission	9 kHz ~ 30 MHz	Line / Neutral	±2.9076 dB
Radiated Emission	9 kHz ~ 25,000 MHz	Vertical / Horizontal	±0.948 dB
20dB Occupied Bandwidth Measurement	-	-	74.224Hz



3. Test Equipment and Ancillaries Used for Tests

Instrument	Manufacturer	Model No.	Serial No.	Calibration Date	Valid Date
EMI Receiver	R&S	ESCI3	100443	2017/03/07	2018/03/06
LISN	Schwarzbeck	NSLK 8127	8127-568	2017/02/15	2018/02/14
Pulse Limiter	R&S	ESH3-Z2	101934	2017/02/14	2018/02/13
Bilog Antenna	Schwarzbeck	VULB9168	369	2017/03/15	2018/03/14
Active Loop Antenna	EMCO	6507	40855	2017/05/15	2018/05/14
Horn Antenna	EMCO	3115	31589	2017/02/18	2018/02/17
Horn Antenna	EMCO	3116	31970	2017/03/29	2018/03/28
EXA Signal Analyzer	KEYSIGHT	N9010A	MY54200207	2017/03/17	2018/03/16
Preamplifier	EM	EM330	60660	2017/02/25	2018/02/24
Preamplifier	EMC INSTRUMENTS	EMC051845SE	980333	2017/09/20	2018/09/19
Preamplifier	Agilent	8449B	3008A01954	2017/02/09	2018/02/08
Preamplifier	EMC INSTRUMENTS	EMC184045	980065	2017/11/03	2018/11/02
MXG MW Analog Signal Generator	KEYSIGHT	N5183A	MY50142931	2017/03/17	2018/03/16
Spectrum Analyzer	R&S	FSP40	100219	2017/07/01	2018/06/30
Bluetooth Tester	R&S	CBT	101133	2017/03/10	2018/03/09
Attenuator	KEYSIGHT	8491B	MY39250703	2017/03/07	2018/03/06
Rotary Attenuator	Agilent	8495B	MY42146680	2017/03/13	2018/03/12
Temp & Humi chamber	T-MACHINE	TMJ-9712	T-12-040111	2017/09/04	2018/09/03
Series Power Meter	Anritsu	ML2495A	1224005	2017/03/01	2018/02/28
Power Sensor	Anritsu	MA2411B	1207295	2017/03/01	2018/02/28
Cable	HUBER SUHNER	SUCOFLEX 102	28422/2	2017/02/25	2018/02/24
Cable	HUBER SUHNER	SUCOFLEX 102	28418/2	2017/02/25	2018/02/24
Software	Farad	Ez-EMC	ver.ct3a1	N/A	N/A
Software	AUDIX	E3	V8.2014-8-6	N/A	N/A
Software	Keysight	N7607B Signal Studio	v2.0.0.1	N/A	N/A
Software	Keysight	Inservice MonitorUtility	N/A	N/A	N/A



4. Antenna Requirements

4.1 Antenna Construction and Directional Gain

Antenna Type: PCB Antenna



5. Test of Conducted Emission

5.1 Test Limit

Conducted Emissions were measured from 150 kHz to 30 MHz with a bandwidth of 9 KHz, according to the methods defined in ANSI C63.4-2014. The EUT was placed on a nonmetallic stand in a shielded room 0.8 meters above the ground plane. The interface cables and equipment positioning were varied within limits of reasonable applications to determine the position produced maximum conducted emissions.

Frequency (MHz)	Quasi Peak (dB μ V)	Average (dB μ V)
0.15 – 0.5	66-56*	56-46*
0.5 – 5.0	56	46
5.0 – 30.0	60	50

*Decreases with the logarithm of the frequency.

5.2 Test Procedures

- The EUT was placed 0.4 meter from the conducting wall of the shielding room was kept at least 80 centimeters from any other grounded conducting surface.
- Connect EUT to the power mains through a line impedance stabilization network (LISN).
- All the support units are connecting to the other LISN.
- The LISN provides 50 ohm coupling impedance for the measuring instrument.
- The FCC states that a 50 ohm, 50 micro-Henry LISN should be used.
- Both sides of AC line were checked for maximum conducted interference.
- The frequency range from 150 kHz to 30 MHz was searched.
- Set the test-receiver system to Peak Detect Function and Specified Bandwidth with Maximum Hold Mode.



5.3 Typical Test Setup

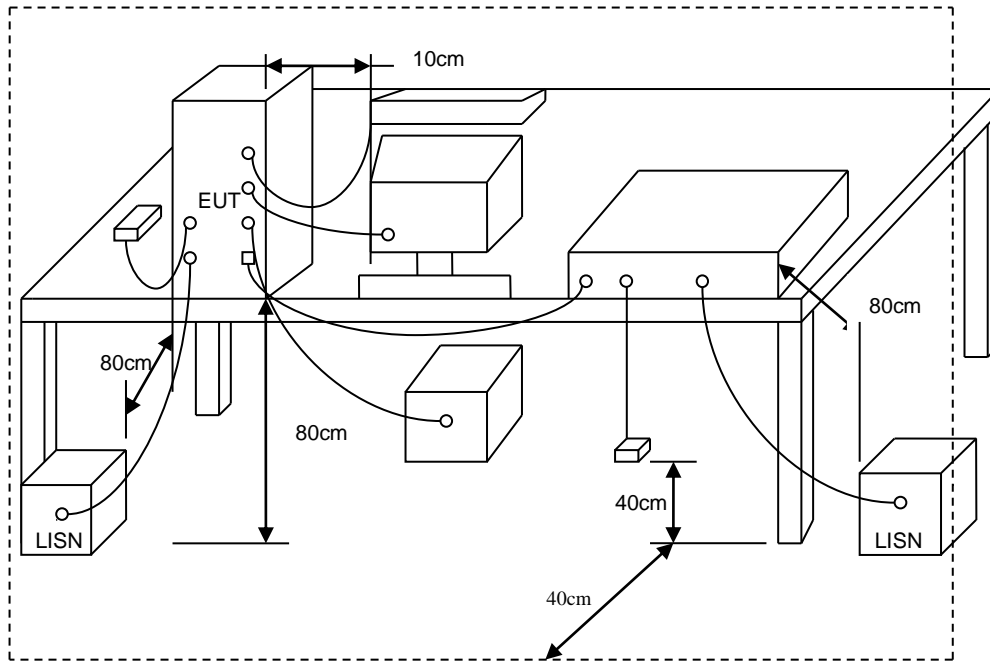

5.4 Test Result and Data

The test item is not applicable because the EUT is powered from battery.



6. Test of Radiated Emission

6.1 Test Limit

According to A1.4(a) the field strength of emissions from intentional radiators operated under these frequencies bands shall not exceed the following:

Frequency (MHz)	Field Strength of Fundamental		Field Strength of Spurious	
	$\mu\text{V}/\text{m}$	$\text{dB}\mu\text{V}/\text{m}$	$\mu\text{V}/\text{m}$	$\text{dB}\mu\text{V}/\text{m}$
70 ~130	500	54	50	34
130 ~ 174	500 ~ 1500	54 ~ 63.5	50 ~ 150	34 ~ 43.5
174 ~ 260	1500	63.5	150	43.5
260 ~ 470	1500 ~ 5000	63.5 ~ 74	150 ~ 500	43.5 ~ 54
Above 470	5000	74	500	54

NOTE:

1. Where F is the frequency in MHz, the formula for calculating the maximum permitted fundamental field strengths are as follows: for the band 130-174 MHz, $\mu\text{V}/\text{m}$ at 3 meters = $22.72727(F)-2454.545$; for the band 260-470 MHz, $\mu\text{V}/\text{m}$ at 3 meters = $16.6667(F)- 2833.3333$. The maximum permitted unwanted emission level is 20 dB below the maximum permitted fundamental level.
2. The above field strength limits are specified at a distance of 3meters. The tighter limits apply at the band edges.

Emissions radiated outside of the specified bands, shall be according to the general radiated limits in RSS-GEN 8.9 as following:

Frequency (MHz)	Distance	Limit ($\mu\text{V}/\text{m}$)
0.09 ~ 0.490	300m	$2400/F(\text{kHz})$
0.490 ~ 1.705	30m	$24000/ F(\text{kHz})$
1.705 ~ 30	30m	30
30 ~ 88	3m	100
88 ~ 216	3m	150
216 ~ 960	3m	200
Above 960	3m	500

the peak field strength of any emission shall not exceed the maximum permitted average limits, specified above by more than 20dB under any condition of modulation.



6.2 Test Procedures

- a. The EUT was placed on a rotatable table top 0.8 meter above ground.
- b. The EUT was set 3 meters from the interference receiving antenna which was mounted on the top of a variable height antenna tower.
- c. The table was rotated 360 degrees to determine the position of the highest radiation.
- d. The antenna is a broadband antenna and its height is varied between one meter and four meters above ground to find the maximum value of the field strength both horizontal polarization and vertical polarization of the antenna are set to make the measurement.
- e. For each suspected emission the EUT was arranged to its worst case and then tune the antenna tower (from 1 M to 4 M) and turn table (from 0 degree to 360 degrees) to find the maximum reading.
- f. Set the test-receiver system to Peak or CISPR quasi-peak Detect Function and specified bandwidth with Maximum Hold Mode.
- g. If the emission level of the EUT in peak mode was 3 dB lower than the limit specified, then testing will be stopped and peak values of EUT will be reported, otherwise, the emissions which do not have 3 dB margin will be repeated one by one using the quasi-peak method and reported.
- h. For testing above 1GHz, the emission level of the EUT in peak mode was 20dB lower than average limit (that means the emission level in peak mode also complies with the limit in average mode), then testing will be stopped and peak values of EUT will be reported, otherwise, the emissions will be measured in average mode again and reported.
- i. "Cone of radiation" has been considered to be 3dB beamwidth of the measurement antenna.

NOTE:

1. The resolution bandwidth and video bandwidth of test receiver/spectrum analyzer is 120kHz for Peak detection (PK) and Quasi-peak detection (QP) at frequency below 1GHz.
2. The resolution bandwidth and video bandwidth of test receiver/spectrum analyzer is 1 MHz for Peak detection at frequency above 1GHz.
3. The Average value = Peak value + 20log(Duty cycle)
4. Duty Factor = 20log(total duty / period of pulse train)
= 20log((Long Pulse + Short Pulse) / period of pulse train)
= 20log[(2 * 8.32ms + 53 * 1.07ms) / 100ms]
= -2.69



Test Date: Oct. 26, 2017

Temperature: 23°C

Humidity: 64%

Period of Pulse Train

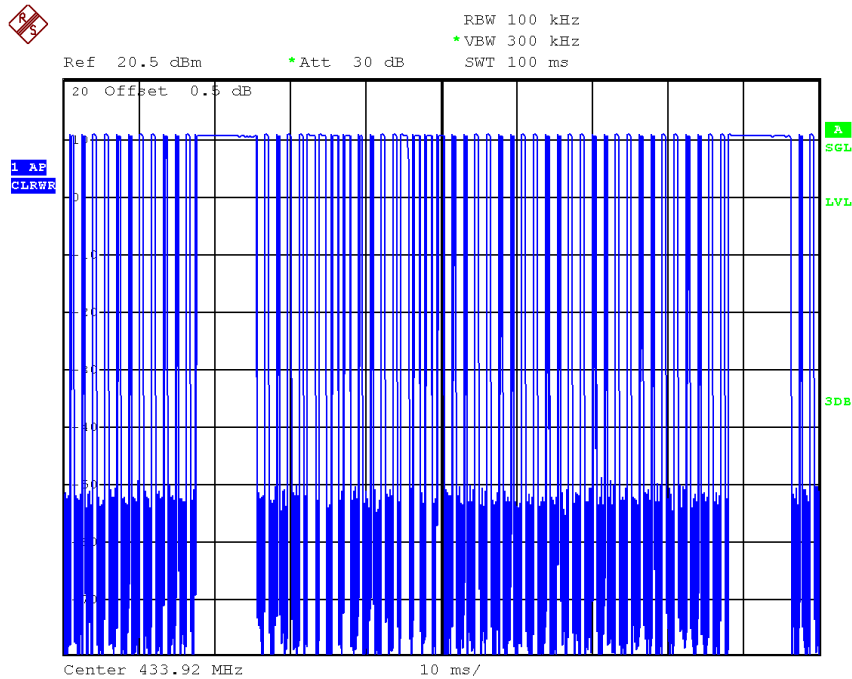

Long Pulse Transmit Time

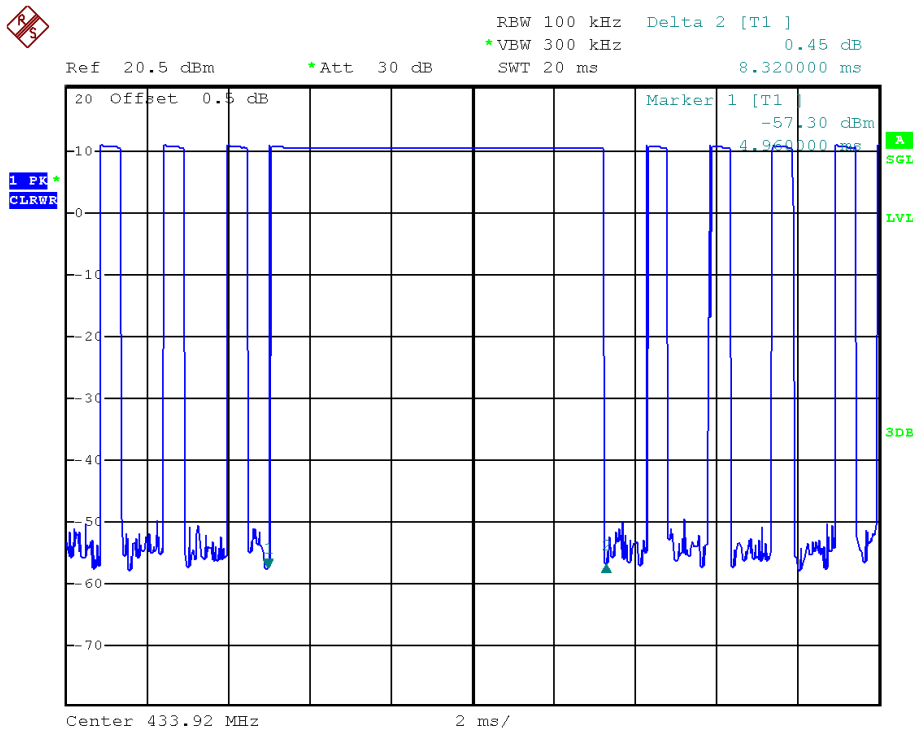



Short Pulse Transmit Time

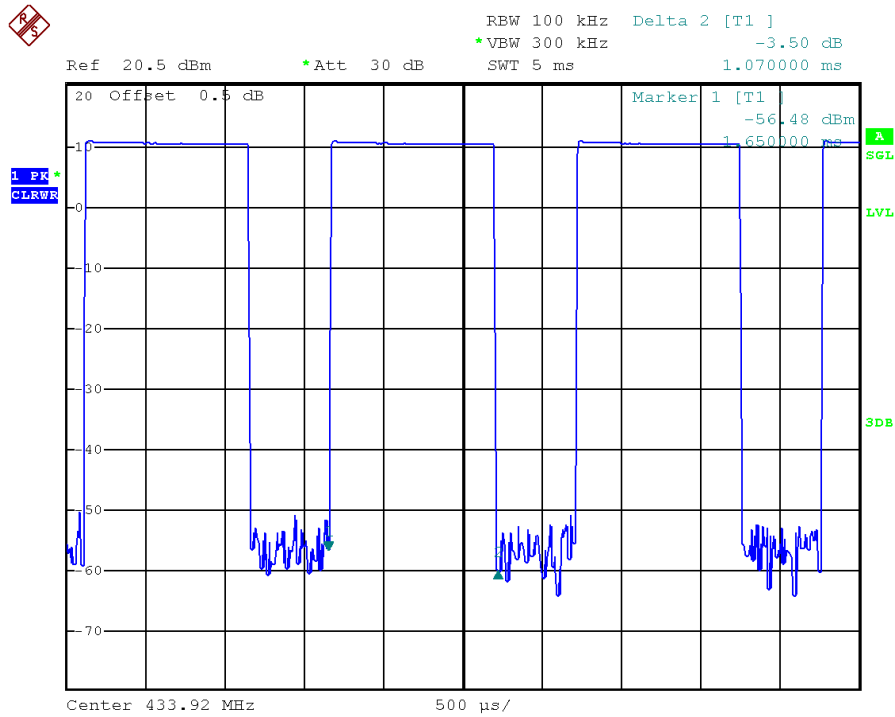



6.3 Typical Test Setup

Below 1GHz Test Setup

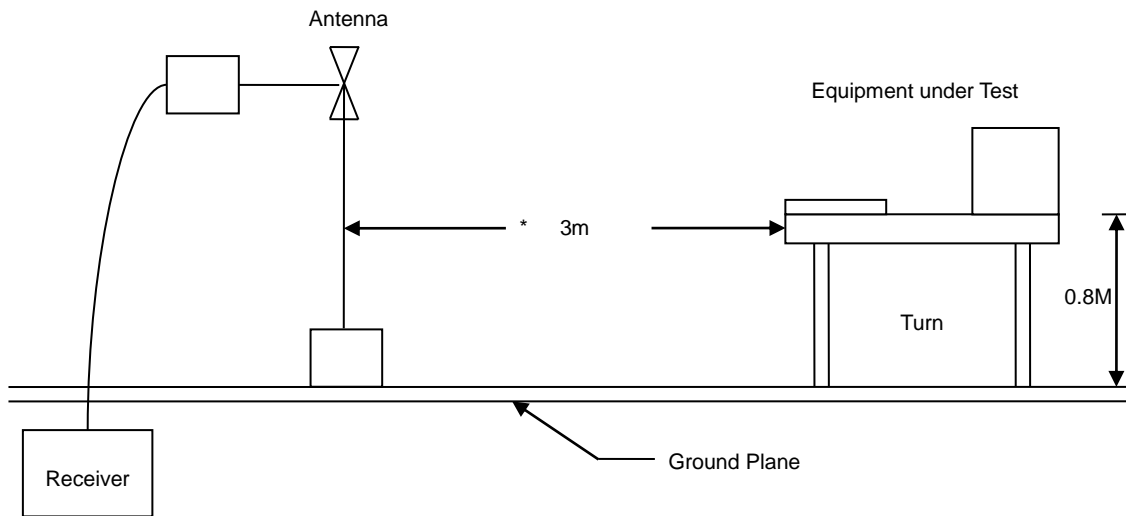

Above 1GHz Test Setup

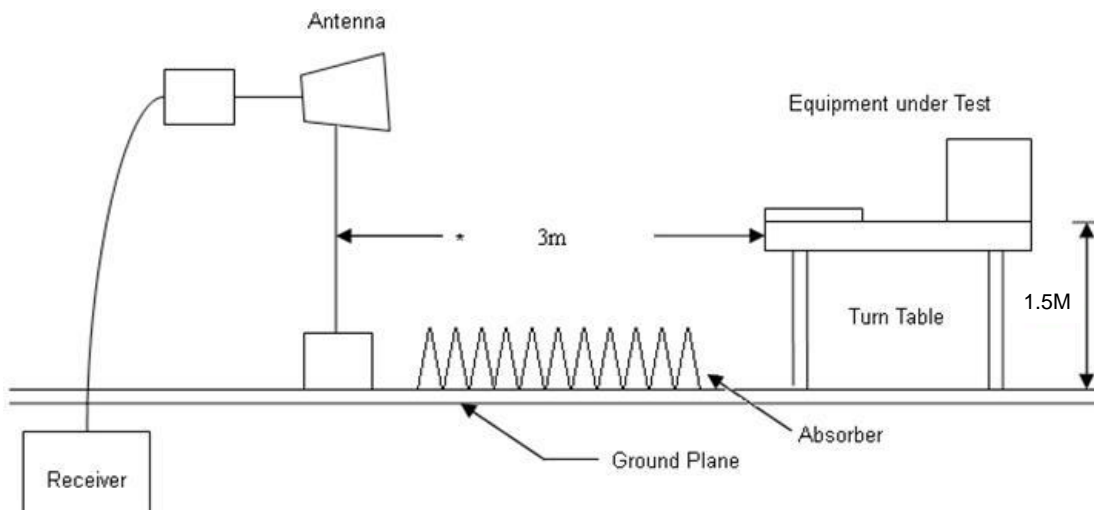



6.4 Test Result and Data

6.4.1 Test Result of Fundamental Emission

Power	: From Battery	Pol/Phase	: VERTICAL
Test Mode	: Transmit	Temperature	: 22 °C
Test Date	: Oct. 26, 2017	Humidity	: 56 %

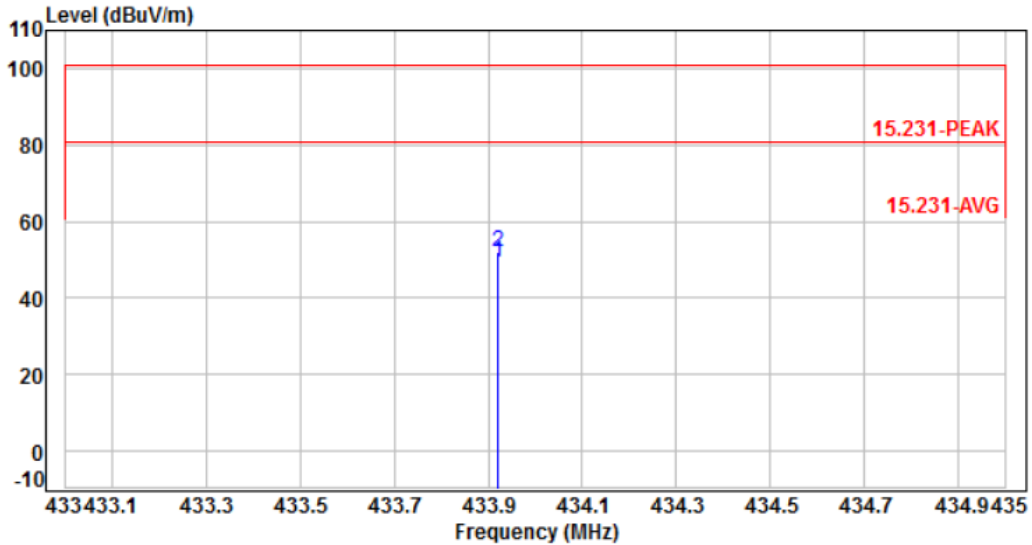

No.	Frequency (MHz)	Factor (dB)	Reading (dBuV)	Level (dBuV)	Limit (dBuV)	Margin (dB)	Detector	Height (cm)	Azimuth (deg)	P/F
1	433.92	-5.16	54.64	49.48	80.83	-31.35	Average	240	59	P
2	433.92	-5.16	57.33	52.17	100.83	-48.66	Peak	240	59	P

Note: Level=Reading+Factor
Margin=Level-Limit
Factor=Antenna Factor + cable loss - Amplifier Factor



Power	: From Battery	Pol/Phase	: HORIZONTAL
Test Mode	: Transmit	Temperature	: 22 °C
Test Date	: Oct. 26, 2017	Humidity	: 56 %

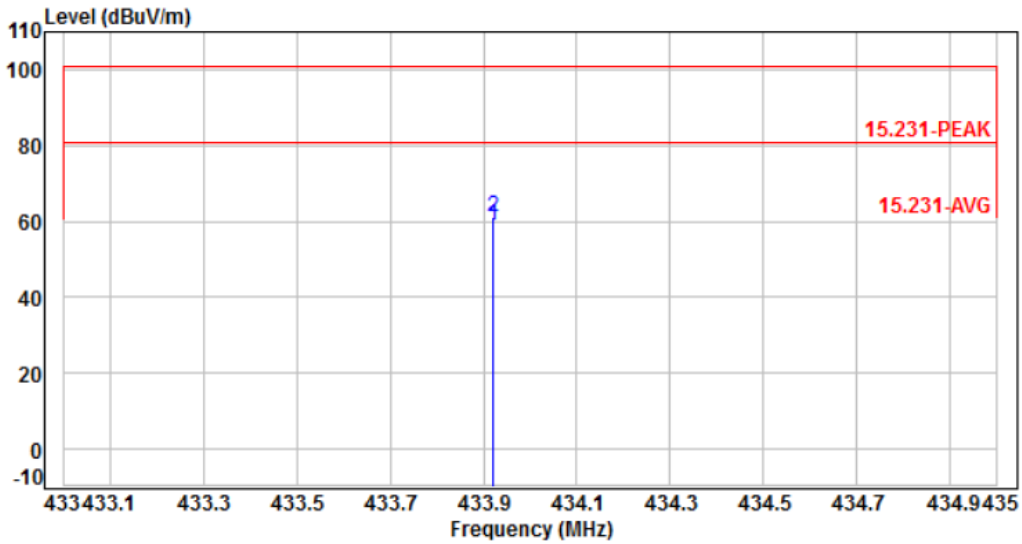

No.	Frequency (MHz)	Factor (dB)	Reading (dBuV)	Level (dBuV)	Limit (dBuV)	Margin (dB)	Detector	Height (cm)	Azimuth (deg)	P/F
1	433.92	-5.16	63.87	58.71	80.83	-22.12	Average	214	321	P
2	433.92	-5.16	66.56	61.40	100.83	-39.43	Peak	214	321	P

Note: Level=Reading+Factor
Margin=Level-Limit
Factor=Antenna Factor + cable loss - Amplifier Factor



6.4.2 Test Result of Field strength of spurious emissions

Power	: From Battery	Pol/Phase	: VERTICAL
Test Mode	: Transmit	Temperature	: 22 °C
Test Date	: Oct. 19, 2017	Humidity	: 56 %

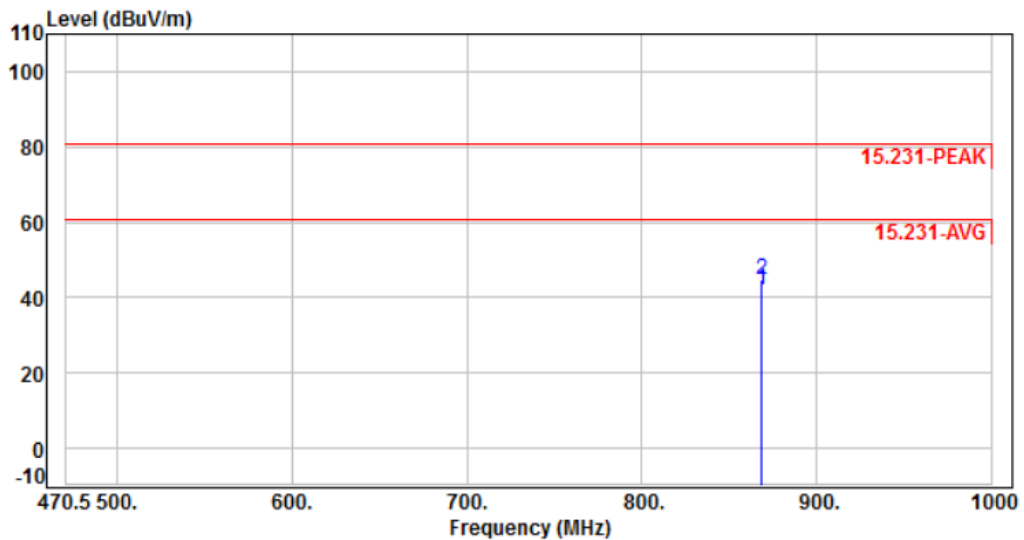

No.	Frequency (MHz)	Factor (dB)	Reading (dBuV)	Level (dBuV)	Limit (dBuV)	Margin (dB)	Detector	Height (cm)	Azimuth (deg)	P/F
1	867.84	2.48	39.71	42.19	60.83	-18.64	Average	150	360	P
2	867.84	2.48	42.40	44.88	80.83	-35.95	Peak	150	360	P

Note: Level=Reading+Factor
Margin=Level-Limit
Factor=Antenna Factor + cable loss - Amplifier Factor



Power	: From Battery	Pol/Phase	: HORIZONTAL
Test Mode	: Transmit	Temperature	: 22 °C
Test Date	: Oct. 19, 2017	Humidity	: 56 %

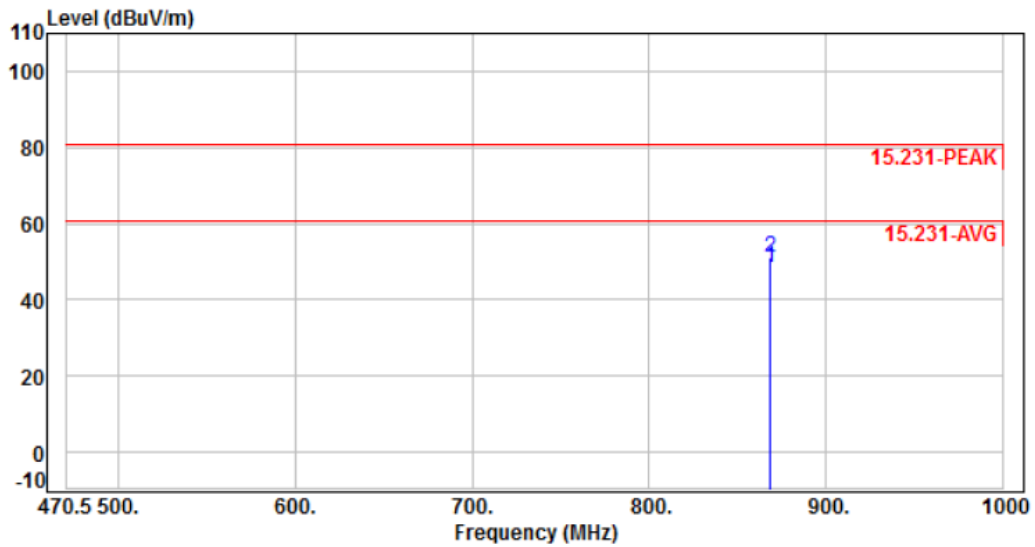

No.	Frequency (MHz)	Factor (dB)	Reading (dBuV)	Level (dBuV)	Limit (dBuV)	Margin (dB)	Detector	Height (cm)	Azimuth (deg)	P/F
1	867.84	2.48	45.81	48.29	60.83	-12.54	Average	100	92	P
2	867.84	2.48	48.50	50.98	80.83	-29.85	Peak	100	92	P

Note: Level=Reading+Factor
Margin=Level-Limit
Factor=Antenna Factor + cable loss - Amplifier Factor



6.4.3 Test Result of Unwanted Spurious emission(30MHz-1GHz)

Power	: From Battery	Pol/Phase	: VERTICAL
Test Mode	: Transmit	Temperature	: 22 °C
Test Date	: Oct. 26, 2017	Humidity	: 56 %

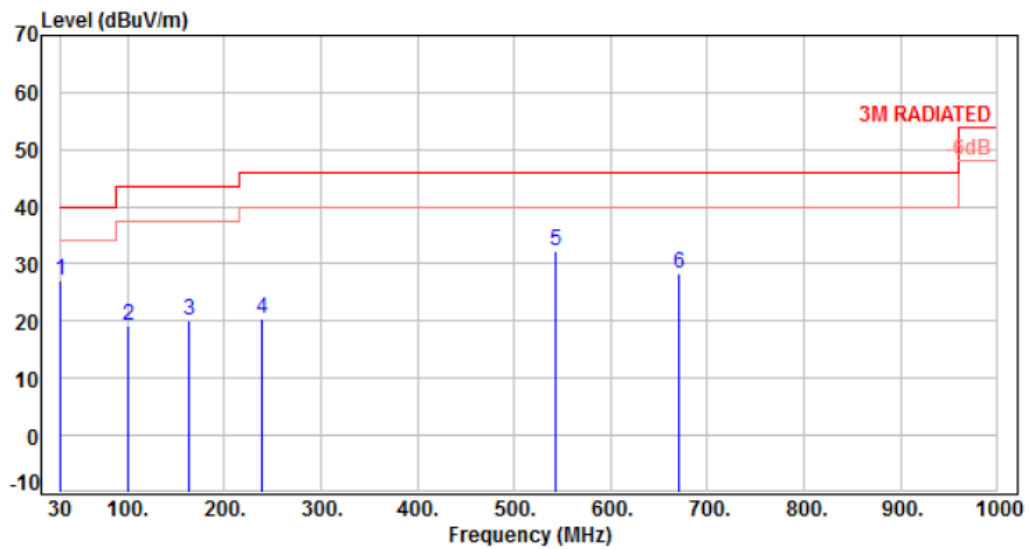

No.	Frequency (MHz)	Factor (dB)	Reading (dBuV)	Level (dBuV)	Limit (dBuV)	Margin (dB)	Detector	Height (cm)	Azimuth (deg)	P/F
1	30.00	-10.92	37.91	26.99	40.00	-13.01	Peak	400	0	P
2	99.84	-15.04	34.12	19.08	43.50	-24.42	Peak	400	0	P
3	163.86	-9.93	29.94	20.01	43.50	-23.49	Peak	400	0	P
4	239.52	-10.81	31.14	20.33	46.00	-25.67	Peak	400	0	P
5	542.16	-3.13	35.36	32.23	46.00	-13.77	Peak	400	0	P
6	671.17	-0.69	29.00	28.31	46.00	-17.69	Peak	400	0	P

Note: Level=Reading+Factor
Margin=Level-Limit
Factor=Antenna Factor + cable loss - Amplifier Factor



Power	: From Battery	Pol/Phase	: HORIZONTAL
Test Mode	: Transmit	Temperature	: 22 °C
Test Date	: Oct. 26, 2017	Humidity	: 56 %

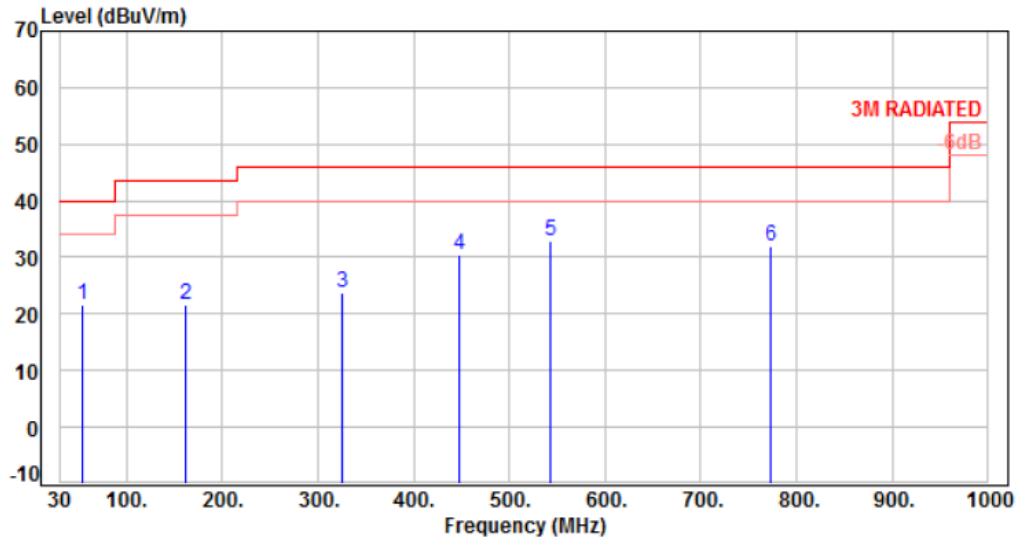

No.	Frequency (MHz)	Factor (dB)	Reading (dBuV)	Level (dBuV)	Limit (dBuV)	Margin (dB)	Detector	Height (cm)	Azimuth (deg)	P/F
1	54.25	-9.92	31.69	21.77	40.00	-18.23	Peak	100	0	P
2	160.95	-9.86	31.64	21.78	43.50	-21.72	Peak	100	0	P
3	325.85	-8.12	31.97	23.85	46.00	-22.15	Peak	100	0	P
4	448.07	-4.81	35.40	30.59	46.00	-15.41	Peak	100	0	P
5	542.16	-3.13	36.03	32.90	46.00	-13.10	Peak	100	0	P
6	773.02	1.11	30.98	32.09	46.00	-13.91	Peak	100	0	P

Note: Level=Reading+Factor
 Margin=Level-Limit
 Factor=Antenna Factor + cable loss - Amplifier Factor



6.4.4 Test Result of Unwanted Spurious emission(Above 1GHz)

Power	: From Battery	Pol/Phase	: VERTICAL
Test Mode	: Transmit	Temperature	: 22 °C
Test Date	: Oct. 26, 2017	Humidity	: 56 %

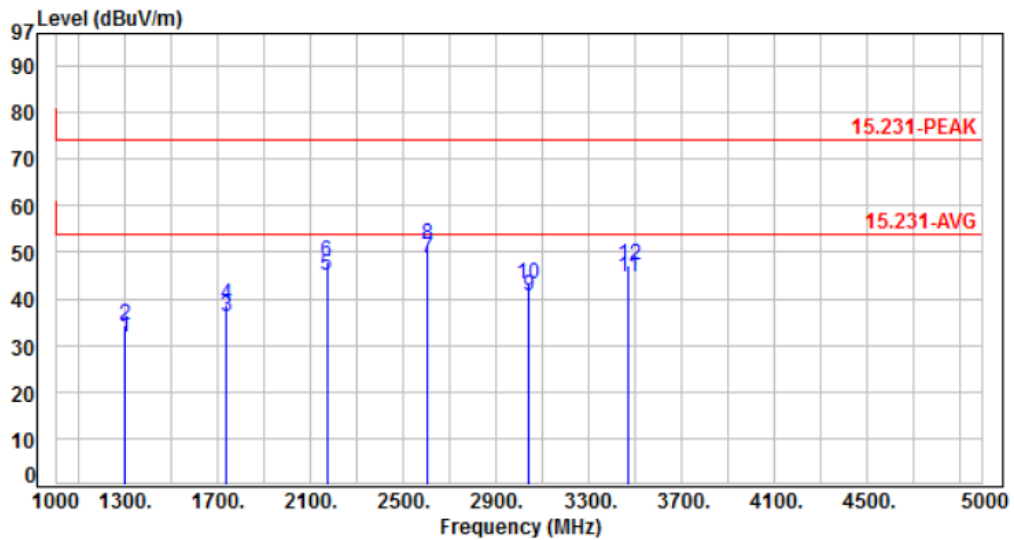

No.	Frequency (MHz)	Factor (dB)	Reading (dBuV)	Level (dBuV)	Limit (dBuV)	Margin (dB)	Detector	Height (cm)	Azimuth (deg)	P/F
1	1301.76	-23.21	54.93	31.72	54.00	-22.28	Average	100	0	P
2	1301.76	-23.21	57.62	34.41	74.00	-39.59	Peak	100	0	P
3	1735.68	-21.43	57.46	36.03	54.00	-17.97	Average	100	0	P
4	1735.68	-21.43	60.15	38.72	74.00	-35.28	Peak	100	0	P
5	2169.60	-19.64	64.75	45.11	54.00	-8.89	Average	100	0	P
6	2169.60	-19.64	67.44	47.80	74.00	-26.20	Peak	100	0	P
7	2603.52	-18.27	67.06	48.79	54.00	-5.21	Average	100	0	P
8	2603.52	-18.27	69.78	51.51	74.00	-22.49	Peak	100	0	P
9	3037.44	-16.65	57.10	40.45	54.00	-13.55	Average	100	0	P
10	3037.44	-16.65	59.79	43.14	74.00	-30.86	Peak	100	0	P
11	3471.36	-15.59	60.10	44.51	54.00	-9.49	Average	100	0	P
12	3471.36	-15.59	62.79	47.20	74.00	-26.80	Peak	100	0	P

Note: Level=Reading+Factor
 Margin=Level-Limit
 Factor=Antenna Factor + cable loss - Amplifier Factor



Power	: From Battery	Pol/Phase	: HORIZONTAL
Test Mode	: Transmit	Temperature	: 22 °C
Test Date	: Oct. 26, 2017	Humidity	: 56 %

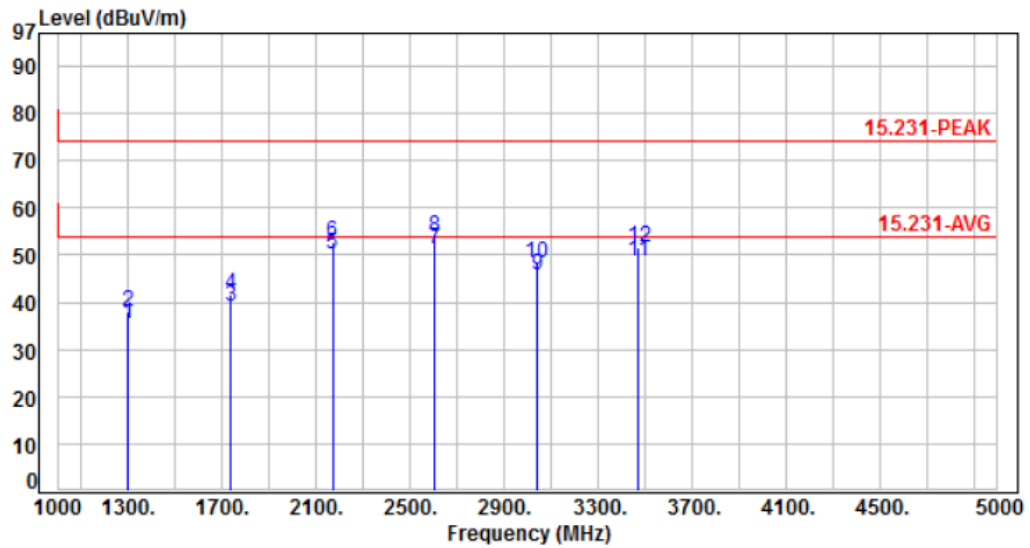

No.	Frequency (MHz)	Factor (dB)	Reading (dBuV)	Level (dBuV)	Limit (dBuV)	Margin (dB)	Detector	Height (cm)	Azimuth (deg)	P/F
1	1301.76	-23.21	58.56	35.35	54.00	-18.65	Average	400	0	P
2	1301.76	-23.21	61.25	38.04	74.00	-35.96	Peak	400	0	P
3	1735.68	-21.43	60.50	39.07	54.00	-14.93	Average	400	0	P
4	1735.68	-21.43	63.19	41.76	74.00	-32.24	Peak	400	0	P
5	2169.60	-19.64	69.67	50.03	54.00	-3.97	Average	400	0	P
6	2169.60	-19.64	72.36	52.72	74.00	-21.28	Peak	400	0	P
7	2603.52	-18.27	69.45	51.18	54.00	-2.82	Average	400	0	P
8	2603.52	-18.27	72.14	53.87	74.00	-20.13	Peak	400	0	P
9	3037.44	-16.65	62.40	45.75	54.00	-8.25	Average	400	0	P
10	3037.44	-16.65	65.09	48.44	74.00	-25.56	Peak	400	0	P
11	3471.36	-15.59	64.37	48.78	54.00	-5.22	Average	400	0	P
12	3471.36	-15.59	67.06	51.47	74.00	-22.53	Peak	400	0	P

Note: Level=Reading+Factor
 Margin=Level-Limit
 Factor=Antenna Factor + cable loss - Amplifier Factor



7. 20dB Bandwidth Measurement

7.1 Test Procedure

- a. The EUT placed on the turning table.
- b. The signal was coupled to the spectrum analyzer through an antenna.
- c. Set the resolution bandwidth to 3kHz and video bandwidth to 10kHz then select Peak function to scan the channel frequency.
- d. The 20dB bandwidth was measured and recorded.

7.2 Test Setup Layout

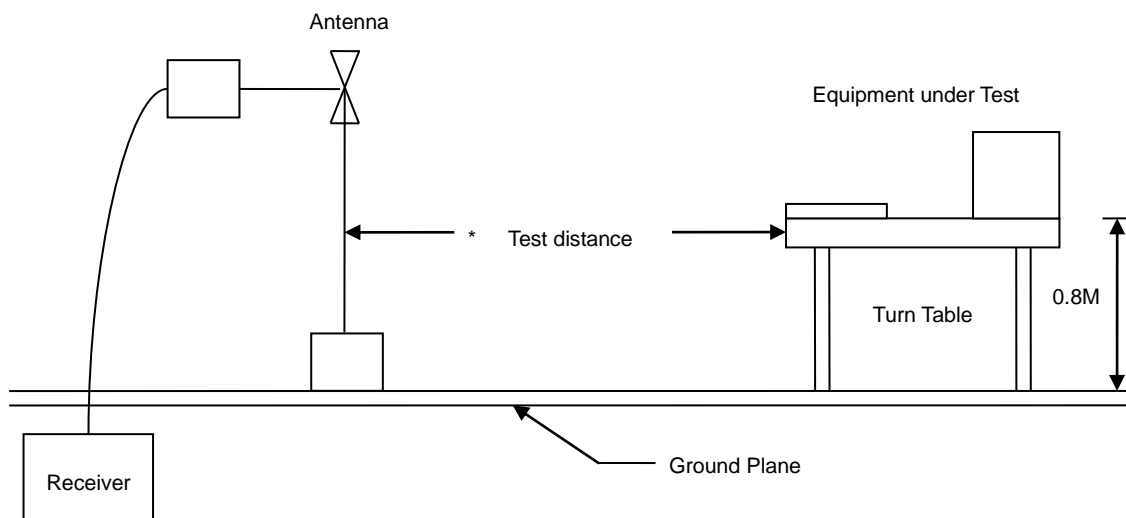

7.3 Limits of Band Edges Measurement

The bandwidth of the emission shall be no wider than 0.25% of the center frequency for device operating above 70 MHz and above 900 MHz.



7.4 Test Result and Data

Test Date: Oct. 26, 2017

Temperature: 23°C

Humidity: 64%

Frequency(MHz)	20dB Bandwidth (MHz)	20dB Bandwidth Limit (MHz)	Pass/Fail
433.92	0.015	1.0848	PASS

Frequency: 433.92MHz, CH1

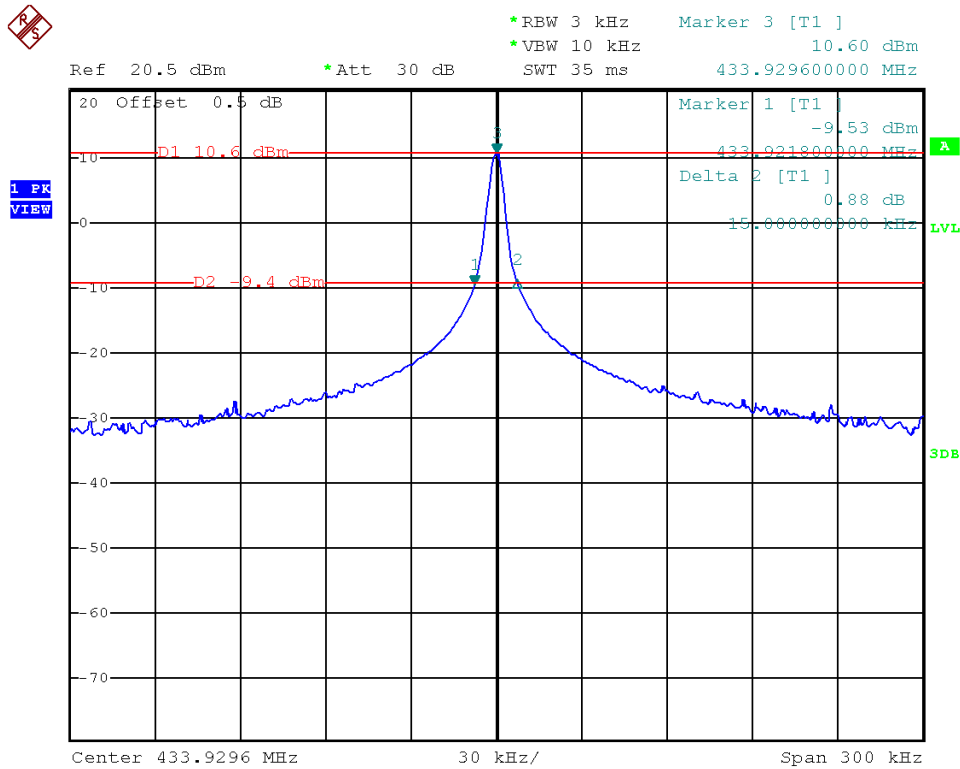



8. Transmission Time Control

8.1 Test Procedure

1. Set up the EUT in the state of Transmitter.
2. Set up the Spectrum, judge whether to accord with the regulation demand or not.

8.2 Test Setup Layout

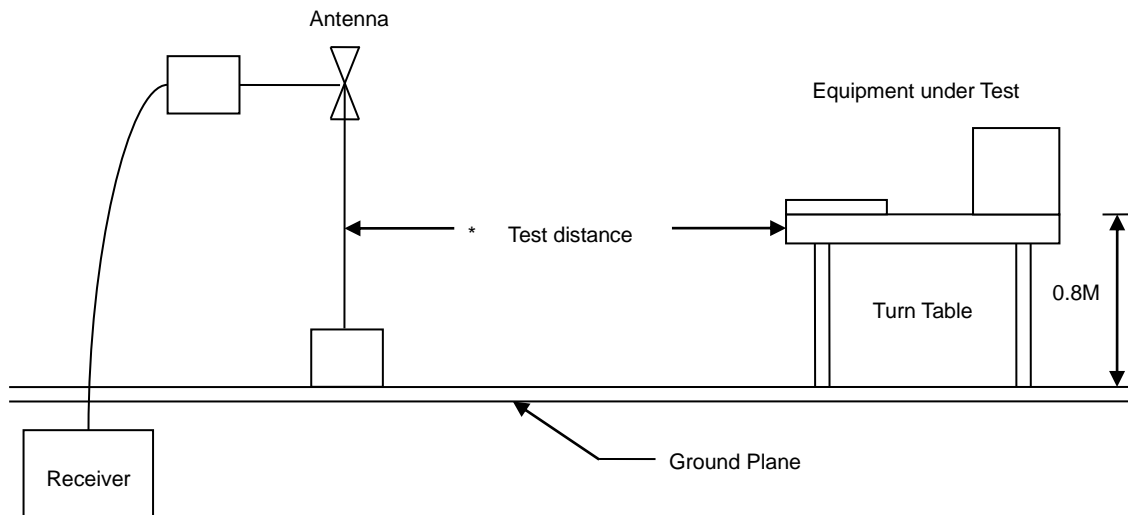

8.3 Test Limit

- a. In addition, devices operated under the provisions of this paragraph shall be provided with a means for automatically limiting operation so that the duration of each transmission shall not be greater than one second and the silent period between transmissions shall be at least 30 times the duration of the transmission but in no case less than 10 seconds.
- b. A manually operated transmitter shall employ a switch that will automatically deactivate the transmitter within not more than 5 seconds of being released.
- c. polling or supervision transmissions, including data, to determine system integrity of transmitters used in security or safety applications are allowed if the total duration of transmissions does not exceed more than two seconds per hour for each transmitter. There is no limit on the number of individual transmissions, provided the total transmission time does not exceed two seconds per hour.



8.4 Test Result and Data

Test Date: Oct. 26, 2017

Temperature: 23°C

Humidity: 64%

A manually operated transmitter shall employ a switch that will automatically deactivate the transmitter within not more than 5 seconds of being released.

Deactivation Time			
Frequency(MHz)	Duration of each transmission(S)	Limit (s)	Pass/Fail
433.92	0.280	5.0	PASS



Frequency: 433.92MHz



Ref -10 dBm *Att 0 dB RBW 100 kHz Delta 3 [T1] 0.70 dB
*VBW 300 kHz SWT 10 s 5.000000 s

