

APPLICATION CERTIFICATION FCC Part 15C&RSS-247

On Behalf of
Edifier International Limited

ACTIVE SPEAKER SYSTEM

Model No.: A100, A100S

FCC ID: Z9G-EDF70

IC: 10004A-EDF70

Prepared for : Edifier International Limited
Address : P.O. Box 6264 General Post Office Hong Kong

Prepared by : Shenzhen Accurate Technology Co., Ltd.
Address : 1/F., Building A, Changyuan New Material Port,
Science & Industry Park, Nanshan District, Shenzhen,
Guangdong, P.R. China.

Tel: (0755) 26503290

Fax: (0755) 26503396

Report No. : ATE20180937
Date of Test : May 07, 2018--May 20, 2018
Date of Report : June 04, 2018

TABLE OF CONTENTS

Description	Page
Test Report Certification	
1. GENERAL INFORMATION	5
1.1. Description of Device (EUT).....	5
1.2. Accessory and Auxiliary Equipment	6
1.3. Model difference declaration	6
1.4. Description of Test Facility	7
1.5. Measurement Uncertainty	7
2. MEASURING DEVICE AND TEST EQUIPMENT	8
3. OPERATION OF EUT DURING TESTING	9
3.1. Operating Mode	9
3.2. Configuration and peripherals	9
4. TEST PROCEDURES AND RESULTS	10
5. 20DB BANDWIDTH TEST.....	11
5.1. Block Diagram of Test Setup.....	11
5.2. The Requirement For Section 15.247(a)(1).....	11
5.3. The Requirement For RSS-247 Section 5.1.....	11
5.4. EUT Configuration on Measurement	11
5.5. Operating Condition of EUT	11
5.6. Test Procedure	12
5.7. Test Result	12
6. CARRIER FREQUENCY SEPARATION TEST.....	16
6.1. Block Diagram of Test Setup.....	16
6.2. The Requirement For Section 15.247(a)(1).....	16
6.3. The Requirement For RSS-247 Section 5.1(b).....	16
6.4. EUT Configuration on Measurement	16
6.5. Operating Condition of EUT	17
6.6. Test Procedure	17
6.7. Test Result	17
7. NUMBER OF HOPPING FREQUENCY TEST	20
7.1. Block Diagram of Test Setup.....	20
7.2. The Requirement For Section 15.247(a)(1)(iii).....	20
7.3. The Requirement For RSS-247 Section 5.1(d).....	20
7.4. EUT Configuration on Measurement	20
7.5. Operating Condition of EUT	20
7.6. Test Procedure	21
7.7. Test Result	21
8. DWELL TIME TEST	22
8.1. Block Diagram of Test Setup.....	22
8.2. The Requirement For Section 15.247(a)(1)(iii).....	22
8.3. The Requirement For Section RSS-247 Section 5.1(d).....	22
8.4. EUT Configuration on Measurement	22
8.5. Operating Condition of EUT	23
8.6. Test Procedure	23
8.7. Test Result	23

9.	MAXIMUM PEAK OUTPUT POWER TEST	34
9.1.	Block Diagram of Test Setup.....	34
9.2.	The Requirement For Section 15.247(b)(1).....	34
9.3.	The Requirement For RSS-247 Section 5.4(b).....	34
9.4.	EUT Configuration on Measurement	34
9.5.	Operating Condition of EUT	34
9.6.	Test Procedure	35
9.7.	Test Result	35
10.	RADIATED EMISSION TEST	39
10.1.	Block Diagram of Test Setup.....	39
10.2.	The Limit For Section 15.247(d)	40
10.3.	Restricted bands of operation	41
10.4.	Configuration of EUT on Measurement	41
10.5.	Test Procedure	42
10.6.	Data Sample.....	42
10.7.	The Field Strength of Radiation Emission Measurement Results	43
11.	BAND EDGE COMPLIANCE TEST	71
11.1.	Block Diagram of Test Setup.....	71
11.2.	The Requirement For Section 15.247(d)	71
11.3.	EUT Configuration on Measurement	71
11.4.	Operating Condition of EUT	71
11.5.	Test Procedure	72
11.6.	Test Result	72
12.	AC POWER LINE CONDUCTED EMISSION FOR FCC PART 15 SECTION 15.207(A) ..	82
12.1.	Block Diagram of Test Setup.....	82
12.2.	Power Line Conducted Emission Measurement Limits.....	82
12.3.	Configuration of EUT on Measurement	82
12.4.	Operating Condition of EUT	83
12.5.	Test Procedure	83
12.6.	Power Line Conducted Emission Measurement Results	83
13.	99% OCCUPIED BANDWIDTH	87
13.1.	The Requirement for RSS-Gen Clause 6.6	87
13.2.	EUT Configuration on Measurement	87
13.3.	Operating Condition of EUT	87
13.4.	Test Procedure	87
13.5.	Measurement Result	88
14.	CONDUCTED SPURIOUS EMISSION COMPLIANCE TEST	92
14.1.	Block Diagram of Test Setup.....	92
14.2.	The Requirement For Section 15.247(d)	92
14.3.	EUT Configuration on Measurement	92
14.4.	Operating Condition of EUT	92
14.5.	Test Procedure	93
14.6.	Test Result	93
15.	ANTENNA REQUIREMENT.....	97
15.1.	The Requirement	97
15.2.	Antenna Construction	97

Test Report Certification

Applicant : Edifier International Limited
Address : P.O. Box 6264 General Post Office Hong Kong
Manufacturer : Dongguan Platinum Audio Systems Co., Ltd.
Address : 6/F, Section 1 Building, No. 2 East Industry Road, Songshan Lake Sci. & Tech. Industrial Park, Dongguan Guangdong 523808, P.R. China.
Product : ACTIVE SPEAKER SYSTEM
Model No. : A100, A100S
Trade name : AIRPULSE

Measurement Procedure Used:

FCC Rules and Regulations Part 15 Subpart C Section 15.247

ANSI C63.10: 2013

RSS-247 Issue 2 February 2017

RSS-Gen Issue 5 April 2018

The device described above is tested by SHENZHEN ACCURATE TECHNOLOGY CO. LTD to determine the maximum emission levels emanating from the device. The maximum emission levels are compared to the FCC Part 15 Subpart C Section 15.247 and RSS-247 limits. The measurement results are contained in this test report and SHENZHEN ACCURATE TECHNOLOGY CO. LTD is assumed full responsibility for the accuracy and completeness of these measurements. Also, this report shows that the Equipment Under Test (EUT) is to be technically compliant with the FCC requirements.

This report applies to above tested sample only. This report shall not be reproduced in part without written approval of SHENZHEN ACCURATE TECHNOLOGY CO. LTD.

Date of Test : May 07, 2018--May 20, 2018

Date of Report: June 04, 2018

Prepared by :

Tim Zhang
(Tim Zhang, Engineer)

Approved &
Authorized Signer :

Sean Liu
(Sean Liu, Manager)

1. GENERAL INFORMATION

1.1. Description of Device (EUT)

EUT	:	ACTIVE SPEAKER SYSTEM
Model Number	:	A100, A100S
Rating	:	AC 100-240V~50/60Hz 500mA
HVIN	:	A100, A100S
Frequency Range	:	2402MHz-2480MHz
Number of Channels	:	79
Antenna Gain(Max)	:	2.87dBi
Antenna type	:	Internal Antenna
Trade Name	:	AIRPULSE
Modulation mode	:	GFSK, $\pi/4$ DQPSK, 8DPSK
Applicant	:	Edifier International Limited
Address	:	P.O. Box 6264 General Post Office Hong Kong
Manufacturer	:	Dongguan Platinum Audio Systems Co., Ltd.
Address	:	6/F, Section 1 Building, No. 2 East Industry Road, Songshan Lake Sci. & Tech. Industrial Park, Dongguan Guangdong 523808, P.R. China.
Date of sample received	:	May 06, 2018
Date of Test	:	May 07, 2018--May 20, 2018

1.2. Accessory and Auxiliary Equipment

1. Iphone6S PLUS
Manufacturer: Apple
Model: ML6D2 CH/A
S/N: C35QJ76JGRWM

2. DVD Player
Manufacturer: KENUO
Model: DVD-966S
S/N: 2003010805086710

3. Notebook PC
Manufacturer: Lenovo
M/N: ThinkPad X240
S/N: n.a

4. Multimedia Player
M/N: STOR.E TV+
Manufacturer: TOSHIBA

1.3. Model difference declaration

A100, A100S are identical in PCB motherboard, driver IC, RF module and Enclosure except the model number is different.

1.4. Description of Test Facility

- EMC Lab : Recognition of accreditation by Federal Communications Commission (FCC)
The Designation Number is CN1189
The Registration Number is 708358
- Listed by Innovation, Science and Economic Development Canada (ISED)
The Registration Number is 5077A-2
- Accredited by China National Accreditation Service for Conformity Assessment (CNAS)
The Registration Number is CNAS L3193
- Accredited by American Association for Laboratory Accreditation (A2LA)
The Certificate Number is 4297.01
- Name of Firm : Shenzhen Accurate Technology Co., Ltd.
Site Location : 1/F., Building A, Changyuan New Material Port, Science & Industry Park, Nanshan District, Shenzhen, Guangdong, P.R. China

1.5. Measurement Uncertainty

- Conducted Emission Expanded Uncertainty = 2.23dB, k=2
- Radiated emission expanded uncertainty (9kHz-30MHz) = 3.08dB, k=2
- Radiated emission expanded uncertainty (30MHz-1000MHz) = 4.42dB, k=2
- Radiated emission expanded uncertainty (Above 1GHz) = 4.06dB, k=2

2. MEASURING DEVICE AND TEST EQUIPMENT

Table 1: List of Test and Measurement Equipment

Kind of equipment	Manufacturer	Type	S/N	Calibrated dates	Calibrated until
EMI Test Receiver	Rohde&Schwarz	ESCS30	100307	Jan. 06, 2018	Jan. 05, 2019
EMI Test Receiver	Rohde&Schwarz	ESPI3	101526/003	Jan. 06, 2018	Jan. 05, 2019
Spectrum Analyzer	Rohde&Schwarz	FSV-40	101495	Jan. 06, 2018	Jan. 05, 2019
Spectrum Analyzer	Agilent	E7405A	MY45115511	Jan. 06, 2018	Jan. 05, 2019
Pre-Amplifier	Rohde&Schwarz	CBLU118354 0-01	3791	Jan. 06, 2018	Jan. 05, 2019
Loop Antenna	Schwarzbeck	FMZB1516	1516131	Jan. 06, 2018	Jan. 05, 2019
Bilog Antenna	Schwarzbeck	VULB9163	9163-323	Jan. 06, 2018	Jan. 05, 2019
Horn Antenna	Schwarzbeck	BBHA9120D	9120D-655	Jan. 06, 2018	Jan. 05, 2019
Horn Antenna	Schwarzbeck	BBHA9170	9170-359	Jan. 06, 2018	Jan. 05, 2019
Open Switch and Control Unit	Rohde&Schwarz	OSP120 + OSP-B157	101244 + 100866	Jan. 06, 2018	Jan. 05, 2019
LISN	Rohde&Schwarz	ESH3-Z5	100305	Jan. 06, 2018	Jan. 05, 2019
LISN	Schwarzbeck	NSLK8126	8126431	Jan. 06, 2018	Jan. 05, 2019
Highpass Filter	Wainwright Instruments	WHKX3.6/18 G-10SS	N/A	Jan. 06, 2018	Jan. 05, 2019
Band Reject Filter	Wainwright Instruments	WRCG2400/2 485-2375/2510 -60/11SS	N/A	Jan. 06, 2018	Jan. 05, 2019

3. OPERATION OF EUT DURING TESTING

3.1. Operating Mode

The mode is used: Transmitting mode

Low Channel: 2402MHz

Middle Channel: 2441MHz

High Channel: 2480MHz

Hopping

3.2. Configuration and peripherals

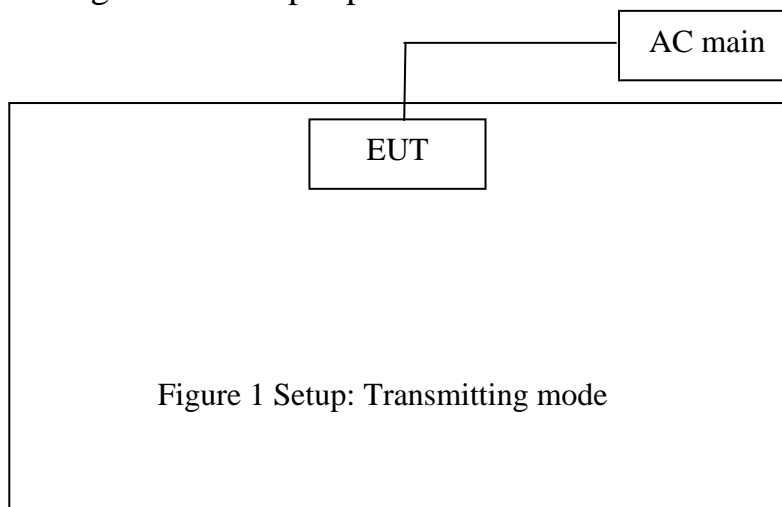

4. TEST PROCEDURES AND RESULTS

FCC&IC Rules	Description of Test	Result
Section 15.207 RSS-Gen Section 8.8	AC Power Line Conducted Emission Test	Compliant
Section 15.247(a)(1) RSS-247 A5.1	20dB Bandwidth Test	Compliant
Section 15.247(a)(1) RSS-247 A5.1	Carrier Frequency Separation Test	Compliant
Section 15.247(a)(1)(iii) RSS-247 A5.1	Number Of Hopping Frequency Test	Compliant
Section 15.247(a)(1)(iii) RSS-247 A5.1	Dwell Time Test	Compliant
Section 15.247(b)(1) RSS-247 A5.4	Maximum Peak Output Power Test	Compliant
Section 15.247(d) Section 15.209 RSS-247 A5.5 RSS-Gen 6.13	Radiated Emission Test	Compliant
RSS-Gen Section 6.7	99% Occupied Bandwidth	Compliant
Section 15.247(d) RSS-247 A5.5	Band Edge Compliance Test	Compliant
Section RSS-247	Conducted Spurious Emission Test	Compliant
Section 15.203 RSS-Gen 6.8	Antenna Requirement	Compliant

5. 20DB BANDWIDTH TEST

5.1. Block Diagram of Test Setup

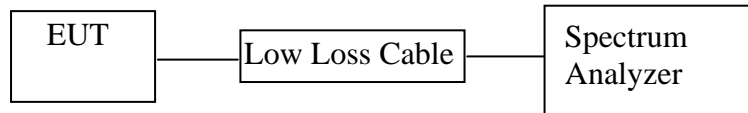

(EUT: ACTIVE SPEAKER SYSTEM)

5.2. The Requirement For Section 15.247(a)(1)

Section 15.247(a)(1): Frequency hopping systems shall have hopping channel carrier frequencies separated by a minimum of 25 kHz or the 20 dB bandwidth of the hopping channel, whichever is greater.

5.3. The Requirement For RSS-247 Section 5.1

RSS-247 Section 5.1(a): The bandwidth of a frequency hopping channel is the 20dB emission bandwidth, measured with the hopping stopped. The system's radio frequency (RF) bandwidth is equal to the channel bandwidth multiplied by the number of channels in the hopset. The system shall hop to channel frequencies that are selected at the system hopping rate from a pseudo randomly ordered list of hopping frequencies. The system receivers shall have input bandwidths that match the hopping channel bandwidths of their corresponding transmitters and shall shift frequencies in synchronization with the transmitted signals.

5.4. EUT Configuration on Measurement

The equipment are installed on the emission measurement to meet the commission requirements and operating regulations in a manner which tends to maximize its emission characteristics in normal application.

5.5. Operating Condition of EUT

5.5.1. Setup the EUT and simulator as shown as Section 5.1.

5.5.2. Turn on the power of all equipment.

5.5.3. Let the EUT work in TX (Hopping off) modes measure it. The transmit frequency are 2402-2480MHz. We select 2402MHz, 2441MHz, and 2480MHz TX frequency to transmit.

5.6. Test Procedure

5.6.1. The transmitter output was connected to the spectrum analyzer through a low loss cable.

5.6.2. The RBW should be 1%~5% of OBW.

5.6.3. The 20dB bandwidth is defined as the total spectrum the power of which is higher than peak power minus 20dB.

5.7. Test Result

Channel	Frequency (MHz)	BDR mode 20dB Bandwidth (MHz)	EDR mode 20dB Bandwidth (MHz)	Result
Low	2402	0.9335	1.2113	Pass
Middle	2441	0.9595	1.2113	Pass
High	2480	0.9595	1.2069	Pass

The spectrum analyzer plots are attached as below.

BDR Mode

Low channel

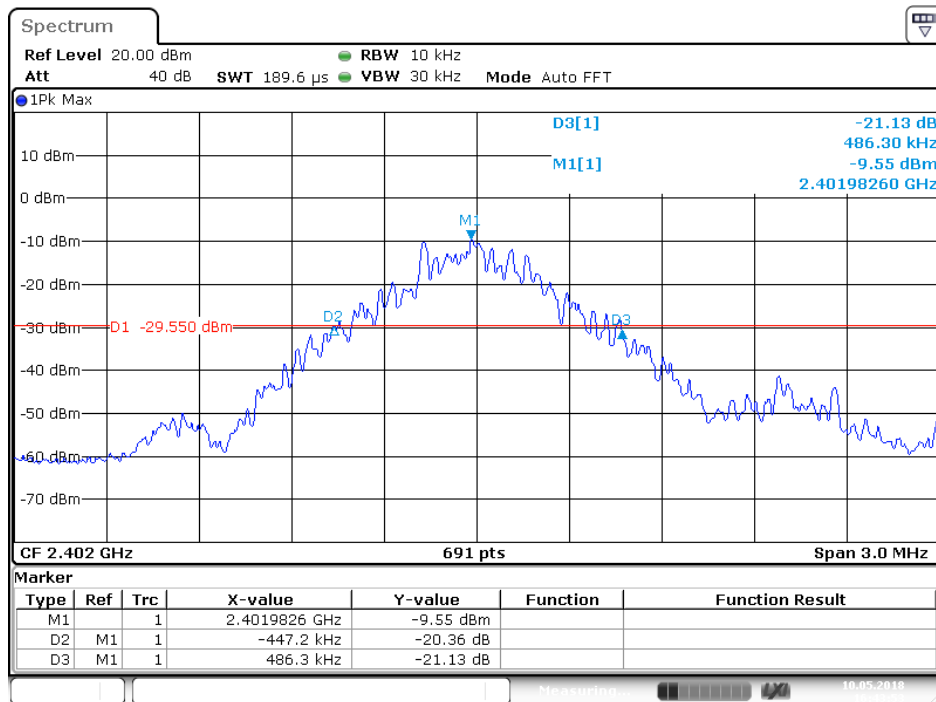

Middle channel

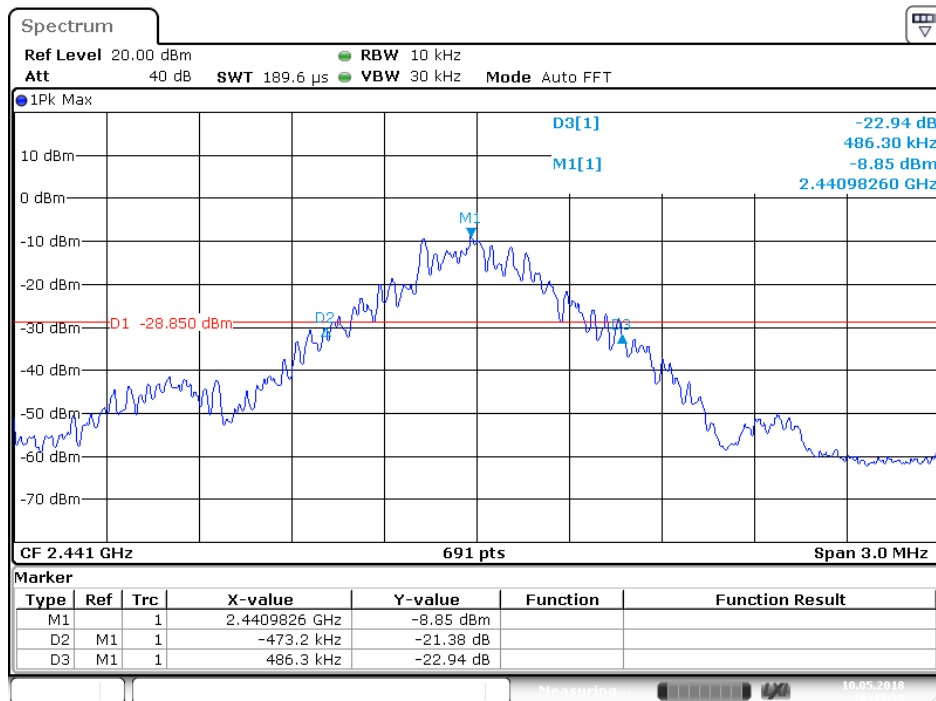

High channel

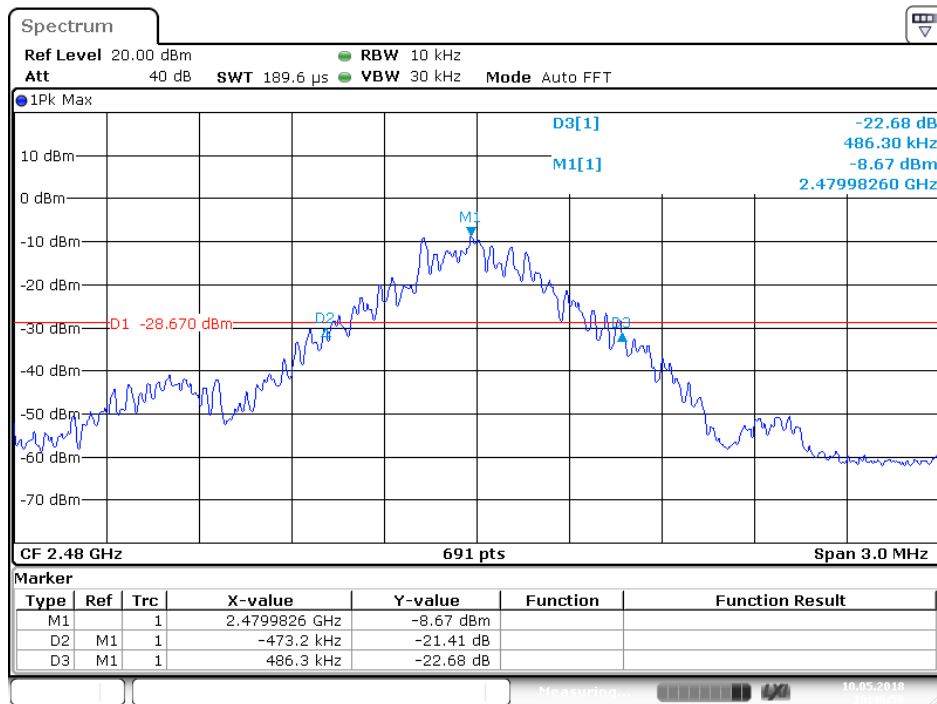

EDR Mode

Low channel

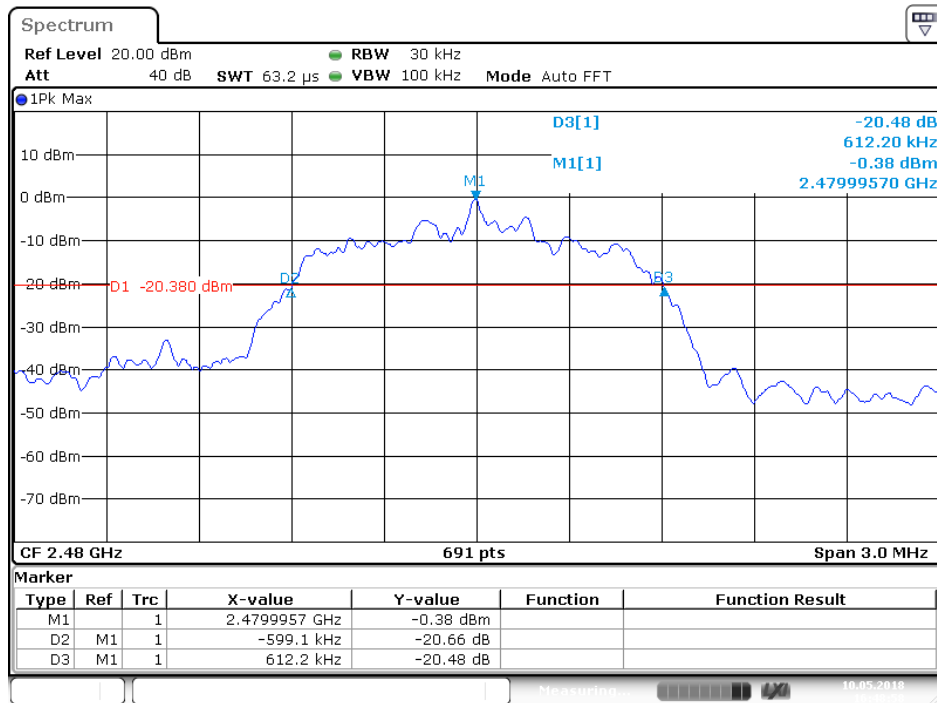

Middle channel

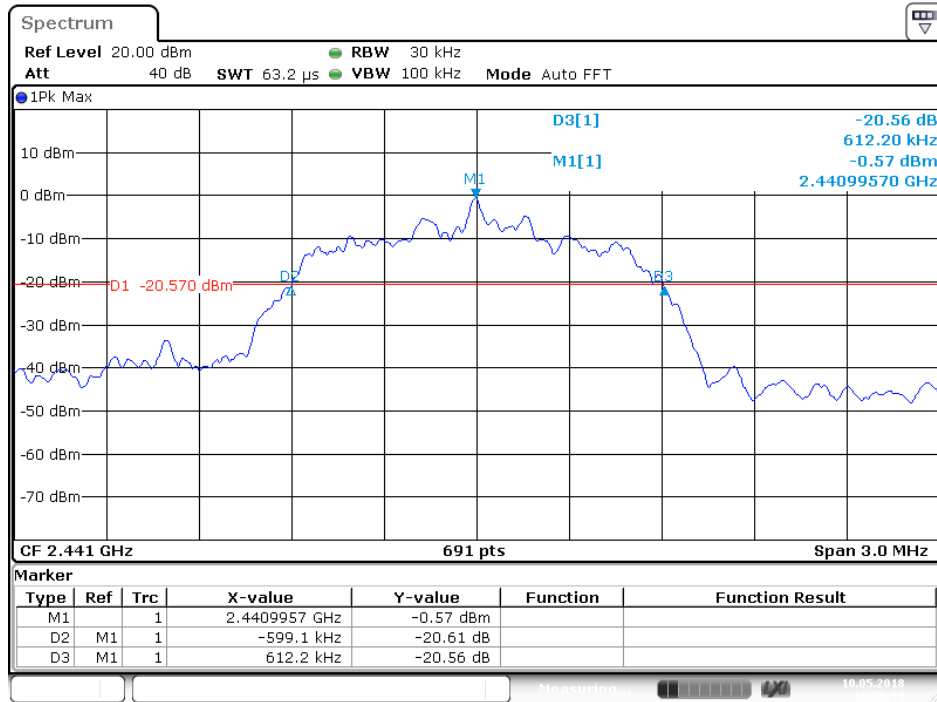

Date: 10.MAY.2018 16:50:20

High channel

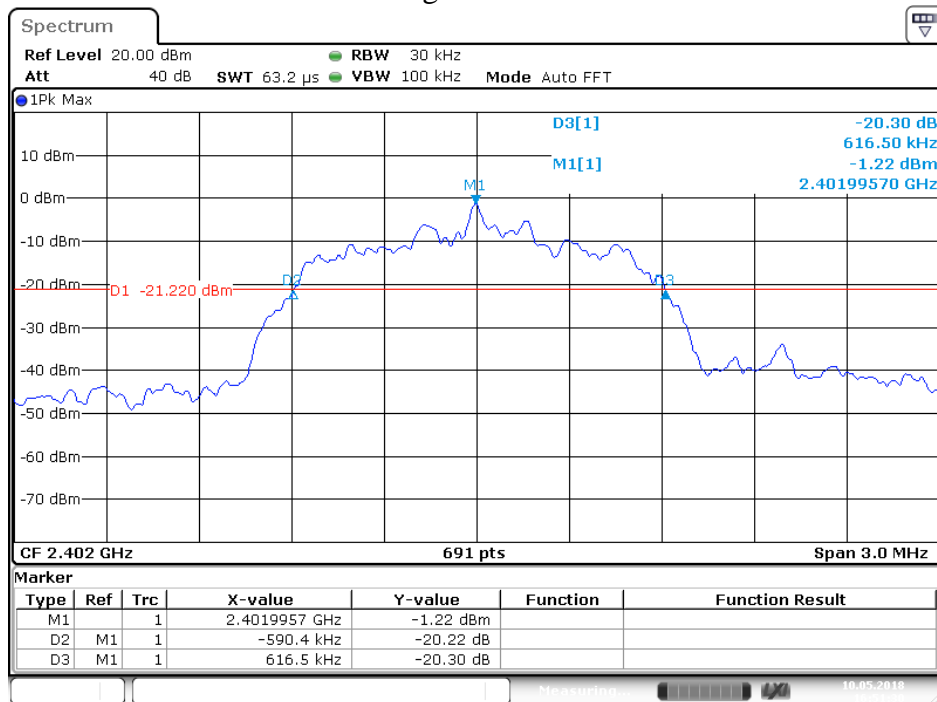

Date: 10.MAY.2018 16:51:31

6. CARRIER FREQUENCY SEPARATION TEST

6.1. Block Diagram of Test Setup



(EUT: ACTIVE SPEAKER SYSTEM)

6.2. The Requirement For Section 15.247(a)(1)

Section 15.247(a)(1): Frequency hopping systems shall have hopping channel carrier frequencies separated by a minimum of 25 kHz or the 20 dB bandwidth of the hopping channel, whichever is greater. Alternatively, frequency hopping systems operating in the 2400-2483.5 MHz band may have hopping channel carrier frequencies that are separated by 25 kHz or two-thirds of the 20 dB bandwidth of the hopping channel, whichever is greater, provided the systems operate with an output power no greater than 125 mW. The system shall hop to channel frequencies that are selected at the system hopping rate from a pseudorandomly ordered list of hopping frequencies. Each frequency must be used equally on the average by each transmitter. The system receivers shall have input bandwidths that match the hopping channel bandwidths of their corresponding transmitters and shall shift frequencies in synchronization with the transmitted signals.

6.3. The Requirement For RSS-247 Section 5.1(b)

RSS-247 Section 5.1(b): FHSS shall have hopping channel carrier frequencies separated by a minimum of 25 kHz or the 20 dB bandwidth of the hopping channel, whichever is greater. Alternatively, FHSs operating in the band 2400-2483.5 MHz may have hopping channel carrier frequencies that are separated by 25 kHz or two thirds of the 20 dB bandwidth of the hopping channel, whichever is greater

6.4. EUT Configuration on Measurement

The equipment are installed on the emission measurement to meet the commission requirements and operating regulations in a manner which tends to maximize its emission characteristics in normal application.

6.5. Operating Condition of EUT

6.5.1. Setup the EUT and simulator as shown as Section 6.1.

6.5.2. Turn on the power of all equipment.

6.5.3. Let the EUT work in TX (Hopping on) modes measure it. The transmit frequency are 2402-2480MHz. We select 2402MHz, 2441MHz, and 2480MHz TX frequency to transmit.

6.6. Test Procedure

6.6.1. The transmitter output was connected to the spectrum analyzer through a low loss cable.

6.6.2. Set RBW of spectrum analyzer to 100 kHz and VBW to 300 kHz. Adjust Span to 3MHz.

6.6.3. Set the adjacent channel of the EUT Maxhold another trace.

6.6.4. Measurement the channel separation

6.7. Test Result

BDR mode

Channel	Frequency (MHz)	Channel Separation(MHz)	Limit (MHz)	Result
Low	2402	1.0029	25KHz or 20dB bandwidth	PASS
	2403			
Middle	2440	1.0029	25KHz or 20dB bandwidth	PASS
	2441			
High	2479	1.0029	25KHz or 20dB bandwidth	PASS
	2480			

The spectrum analyzer plots are attached as below.

BDR Mode

Low channel

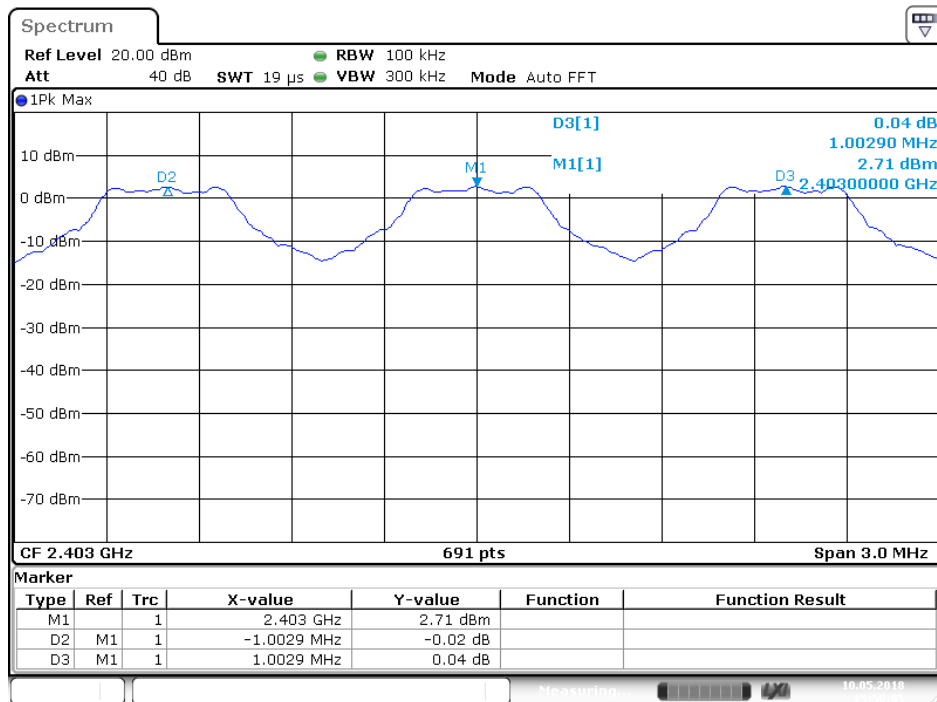

Date: 10.MAY.2018 15:50:04

Middle channel

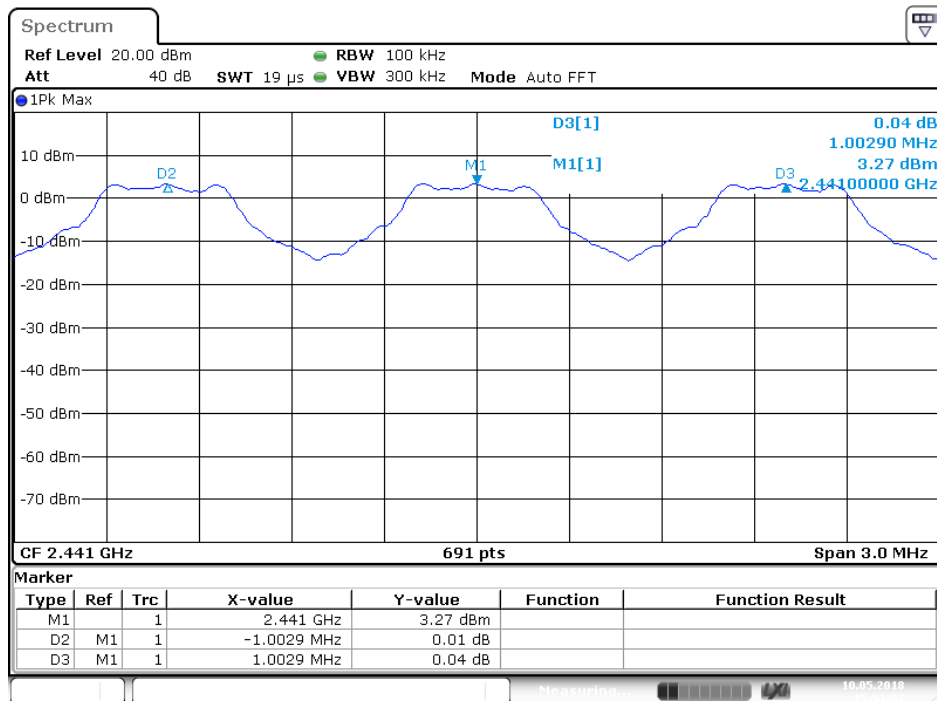

Date: 10.MAY.2018 15:51:06

High channel

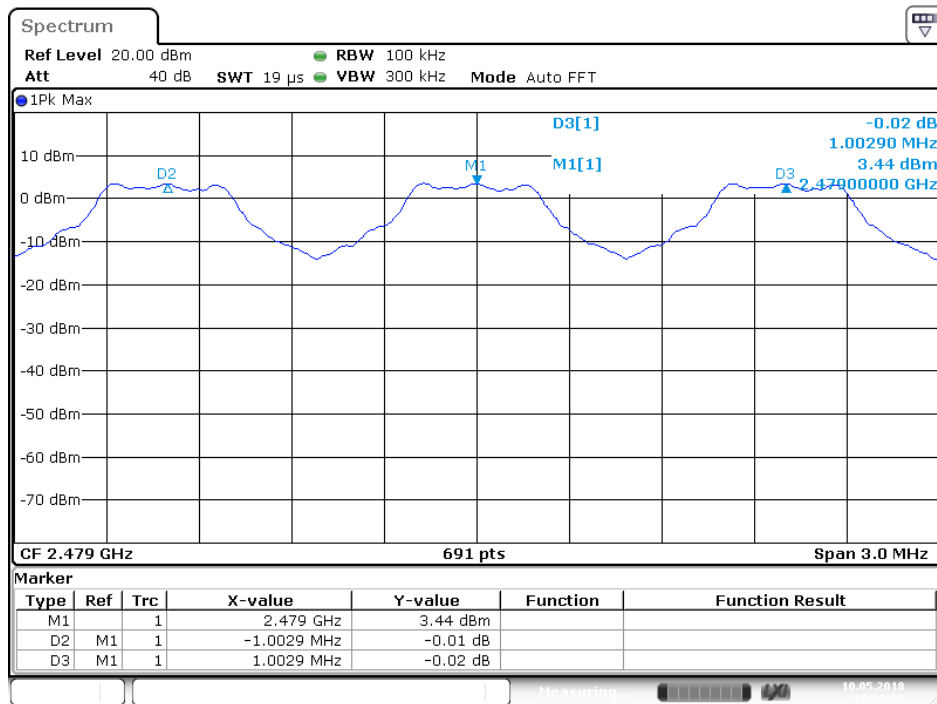

Date: 10.MAY.2018 15:52:59

7. NUMBER OF HOPPING FREQUENCY TEST

7.1. Block Diagram of Test Setup



(EUT: ACTIVE SPEAKER SYSTEM)

7.2. The Requirement For Section 15.247(a)(1)(iii)

Section 15.247(a)(1)(iii): Frequency hopping systems in the 2400-2483.5 MHz band shall use at least 15 channels.

7.3. The Requirement For RSS-247 Section 5.1(d)

RSS-247 Section 5.1(d): Frequency hopping systems in the 2400-2483.5 MHz band shall use at least 15 channels.

7.4. EUT Configuration on Measurement

The equipment are installed on the emission measurement to meet the commission requirements and operating regulations in a manner which tends to maximize its emission characteristics in normal application.

7.5. Operating Condition of EUT

7.5.1. Setup the EUT and simulator as shown as Section 7.1.

7.5.2. Turn on the power of all equipment.

7.5.3. Let the EUT work in TX (Hopping on) modes measure it.

7.6. Test Procedure

7.6.1. The transmitter output was connected to the spectrum analyzer through a low loss cable.

7.6.2. Set the spectrum analyzer as Span=90MHz, RBW=100 kHz, VBW=300 kHz.

7.6.3. Max hold, view and count how many channel in the band.

7.7. Test Result

Total number of hopping channel	Measurement result(CH)	Limit(CH)
	79	≥ 15

The spectrum analyzer plots are attached as below.

Number of hopping channels(GFSK)

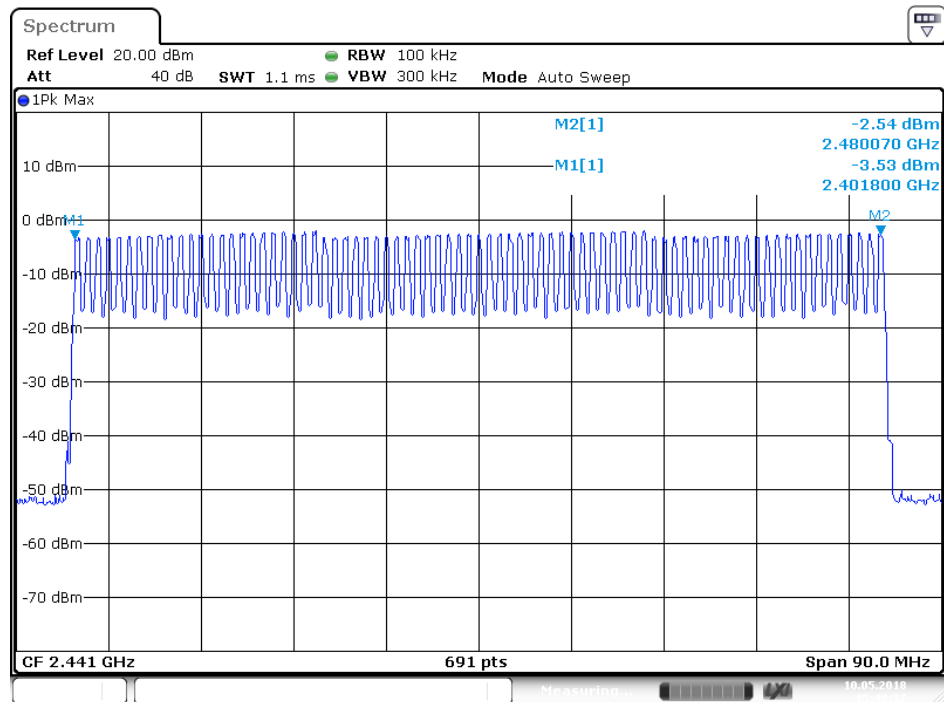

Date: 10.MAY.2018 15:48:37

8. DWELL TIME TEST

8.1. Block Diagram of Test Setup

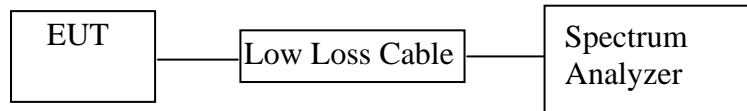

(EUT: ACTIVE SPEAKER SYSTEM)

8.2. The Requirement For Section 15.247(a)(1)(iii)

Section 15.247(a)(1)(iii): Frequency hopping systems in the 2400-2483.5 MHz band shall use at least 15 channels. The average time of occupancy on any channel shall not be greater than 0.4 seconds within a period of 0.4 seconds multiplied by the number of hopping channels employed. Frequency hopping systems may avoid or suppress transmissions on a particular hopping frequency provided that a minimum of 15 channels are used.

8.3. The Requirement For Section RSS-247 Section 5.1(d)

RSS-247 Section 5.1(d): Frequency hopping systems in the 2400-2483.5 MHz band shall use at least 15 channels. The average time of occupancy on any channel shall not be greater than 0.4 seconds within a period of 0.4 seconds multiplied by the number of hopping channels employed. Frequency hopping systems may avoid or suppress transmissions on a particular hopping frequency provided that a minimum of 15 channels are used.

8.4. EUT Configuration on Measurement

The equipment are installed on the emission measurement to meet the commission requirements and operating regulations in a manner which tends to maximize its emission characteristics in normal application.

8.5. Operating Condition of EUT

8.5.1. Setup the EUT and simulator as shown as Section 8.1.

8.5.2. Turn on the power of all equipment.

8.5.3. Let the EUT work in TX (Hopping on) modes measure it. The transmit frequency are 2402-2480MHz. We select 2402MHz, 2441MHz, and 2480MHz TX frequency to transmit.

8.6. Test Procedure

8.6.1. The transmitter output was connected to the spectrum analyzer through a low loss cable.

8.6.2. Set center frequency of spectrum analyzer = operating frequency.

8.6.3. Set the spectrum analyzer as RBW=1MHz, VBW=3MHz, Span=0Hz, Adjust Sweep=5ms, 10ms, 15ms. Get the pulse time.

8.6.4. Repeat above procedures until all frequency measured were complete.

8.7. Test Result

BDR Mode

Mode	Channel Frequency (MHz)	Pulse Time (ms)	Dwell Time (ms)	Limit (ms)
DH1	2402	0.43478	139.130	400
	2441	0.43478	139.130	400
	2480	0.42754	136.813	400
A period transmit time = $0.4 \times 79 = 31.6$ Dwell time = pulse time $\times (1600/(2*79)) \times 31.6$				
DH3	2402	1.7246	275.936	400
	2441	1.7101	273.616	400
	2480	1.7101	273.616	400
A period transmit time = $0.4 \times 79 = 31.6$ Dwell time = pulse time $\times (1600/(4*79)) \times 31.6$				
DH5	2402	3.0000	320.000	400
	2441	2.9565	315.360	400
	2480	2.9565	315.360	400
A period transmit time = $0.4 \times 79 = 31.6$ Dwell time = pulse time $\times (1600/(6*79)) \times 31.6$				

EDR Mode

Mode	Channel Frequency (MHz)	Pulse Time (ms)	Dwell Time (ms)	Limit (ms)
DH1	2402	0.44203	141.450	400
	2441	0.44928	143.770	400
	2480	0.44203	141.450	400
A period transmit time = $0.4 \times 79 = 31.6$ Dwell time = pulse time $\times (1600/(2*79)) \times 31.6$				
DH3	2402	1.7101	273.616	400
	2441	1.7246	275.936	400
	2480	1.7101	273.616	400
A period transmit time = $0.4 \times 79 = 31.6$ Dwell time = pulse time $\times (1600/(4*79)) \times 31.6$				
DH5	2402	2.9783	317.685	400
	2441	3.0000	320.000	400
	2480	2.9783	317.685	400
A period transmit time = $0.4 \times 79 = 31.6$ Dwell time = pulse time $\times (1600/(6*79)) \times 31.6$				

The spectrum analyzer plots are attached as below.

BDR Mode

shenzhen Accurate Technology Co., Ltd.

Address: 1/F., Building A, Changyuan New Material Port, Science & Industry Park, Nanshan District, Shenzhen, Guangdong, P.R. China

Tel: +86-755-26503290

Fax: +86-755-26503396

E-mail: webmaster@atc-lab.com

Http://www.atc-lab.com

DH1 Low channel

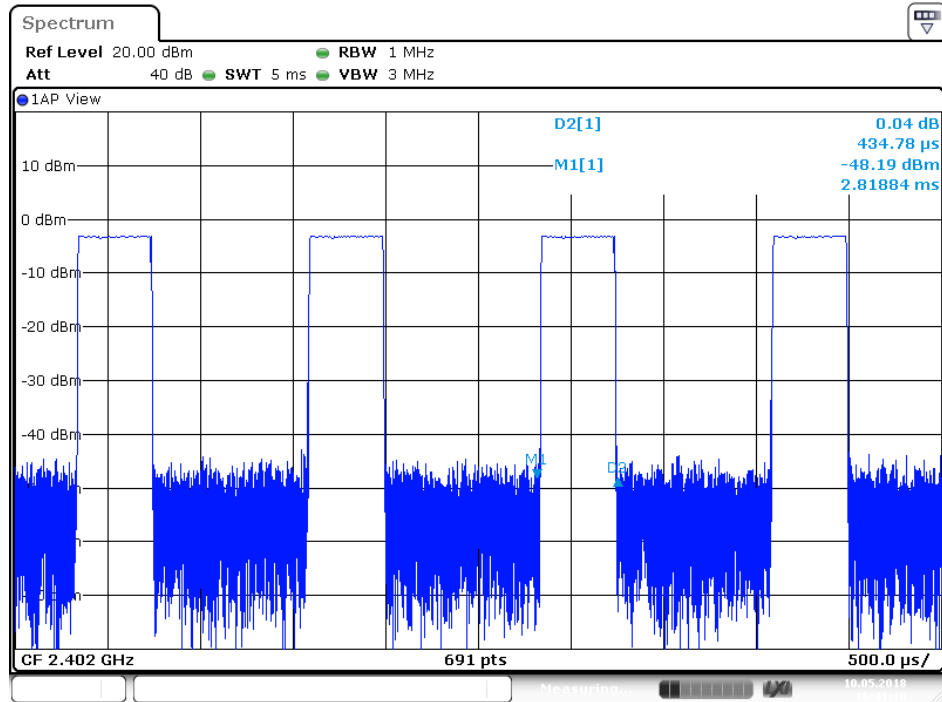

Date: 10.MAY.2018 16:41:11

DH1 Middle channel

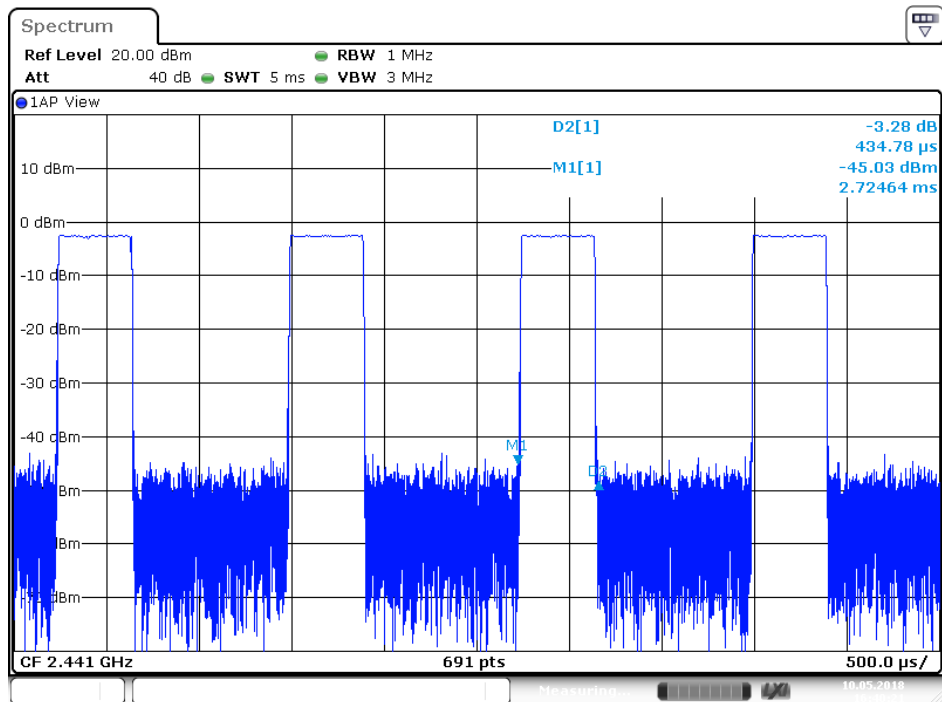

Date: 10.MAY.2018 16:40:22

DH1 High channel

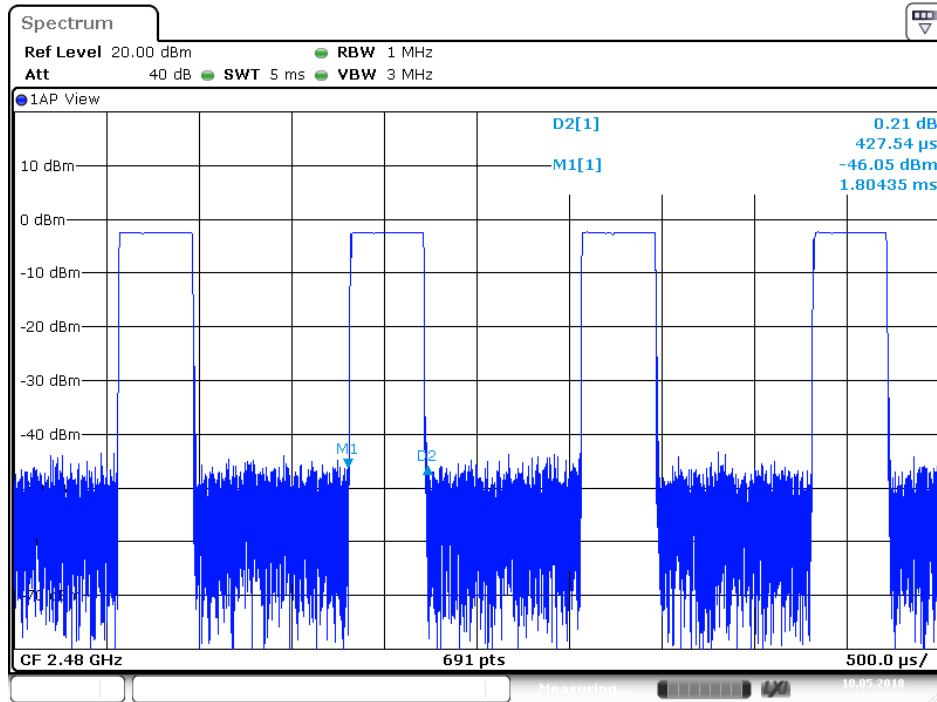

DH3 Low channel

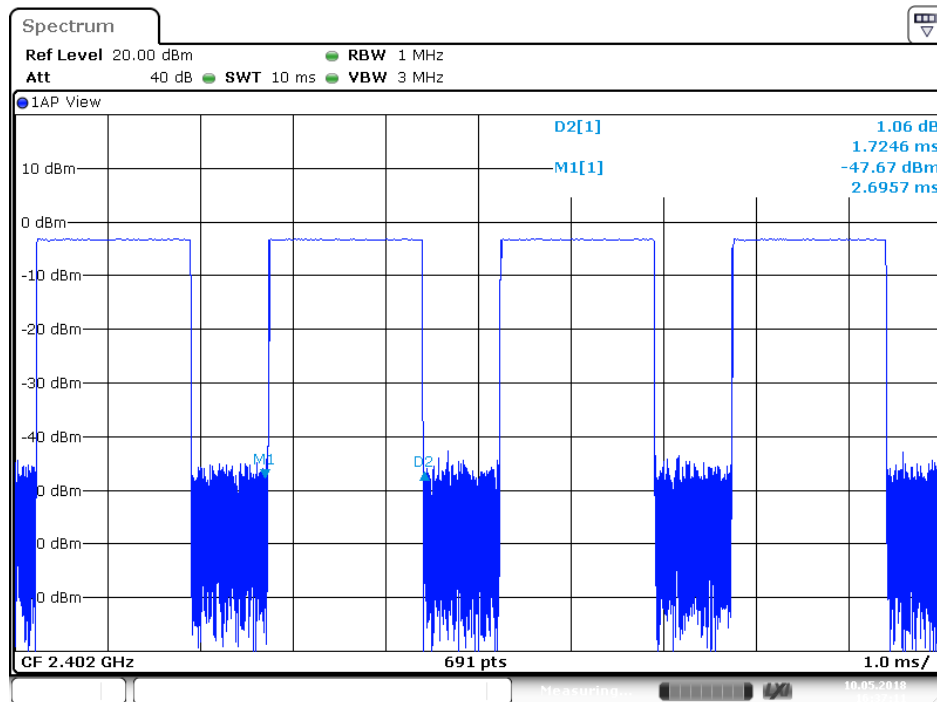

DH3 Middle channel

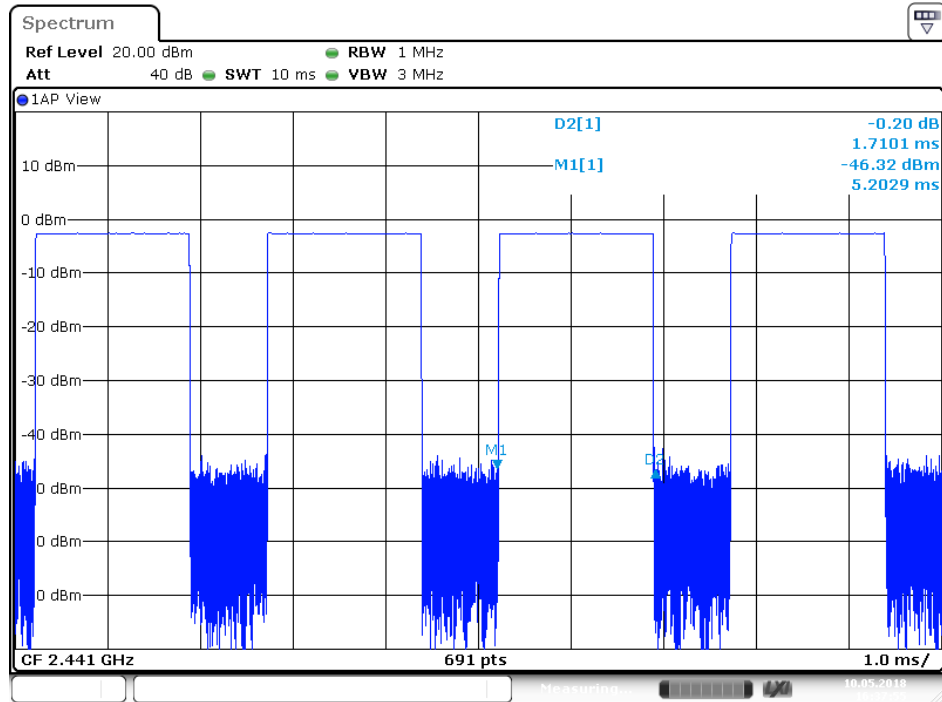

Date: 10.MAY.2018 16:37:56

DH3 High channel

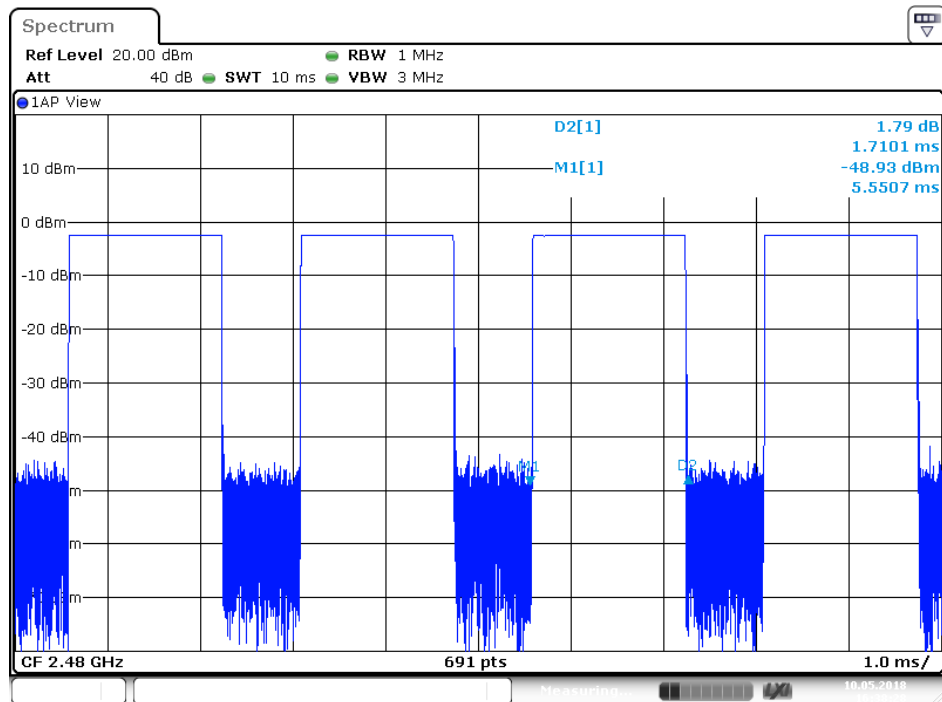

Date: 10.MAY.2018 16:38:28

DH5 Low channel

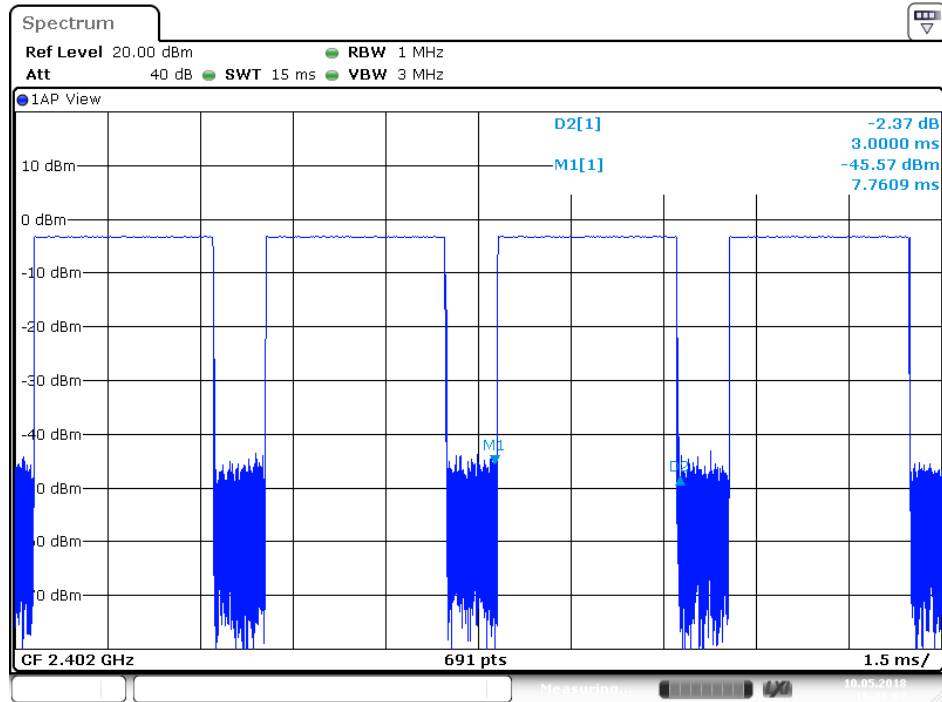

DH5 Middle channel

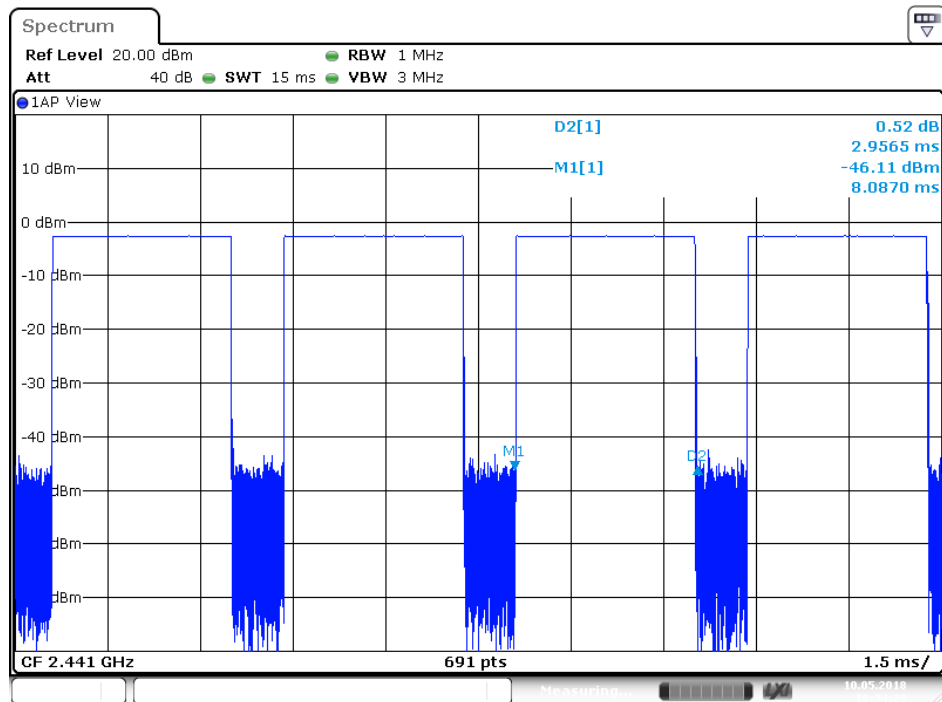

DH5 High channel

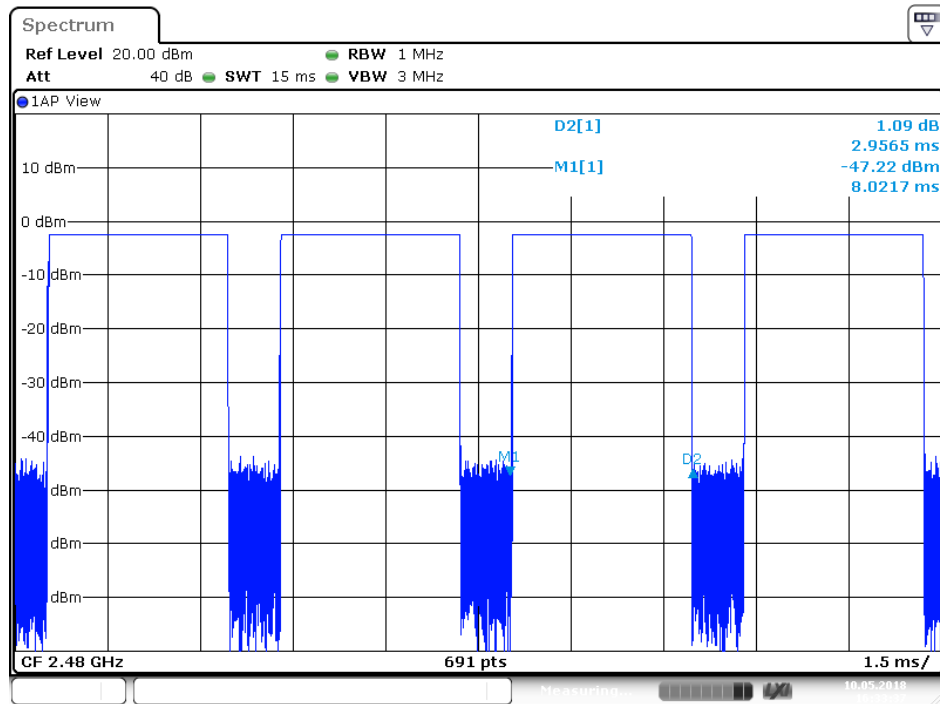

EDR Mode

3DH1 Low channel

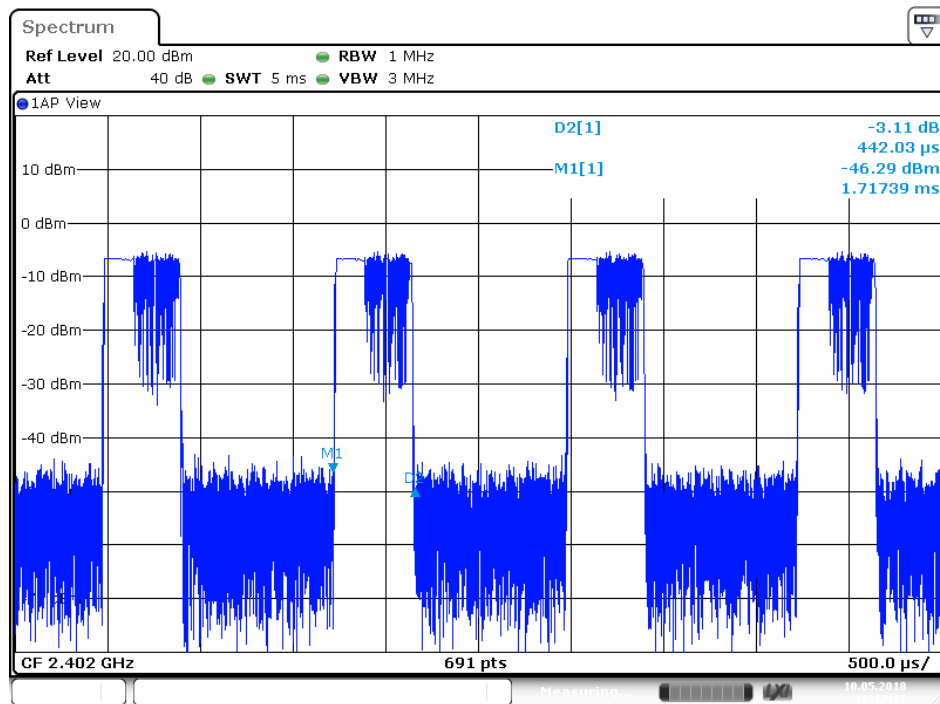

3DH1 Middle channel

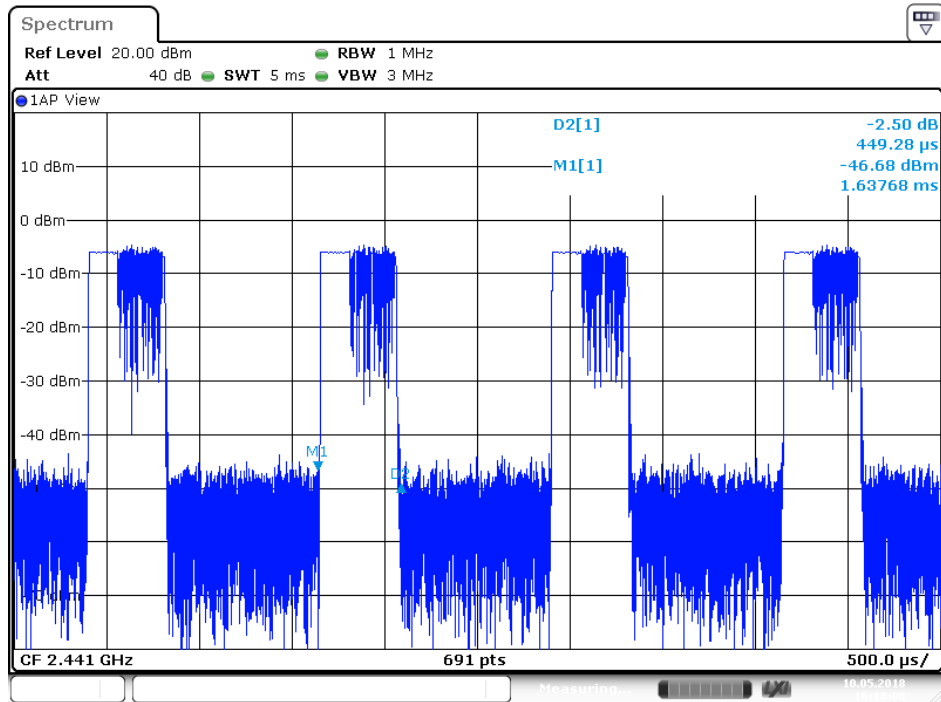

Date: 10.MAY.2018 16:18:09

3DH1 High channel

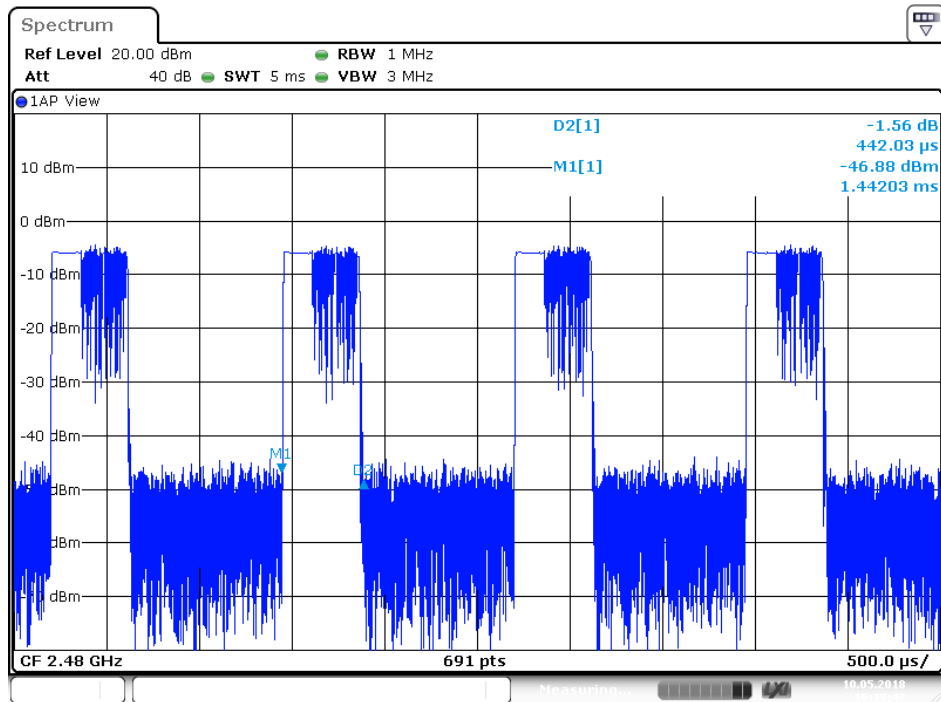

Date: 10.MAY.2018 16:18:46

3DH3 Low channel

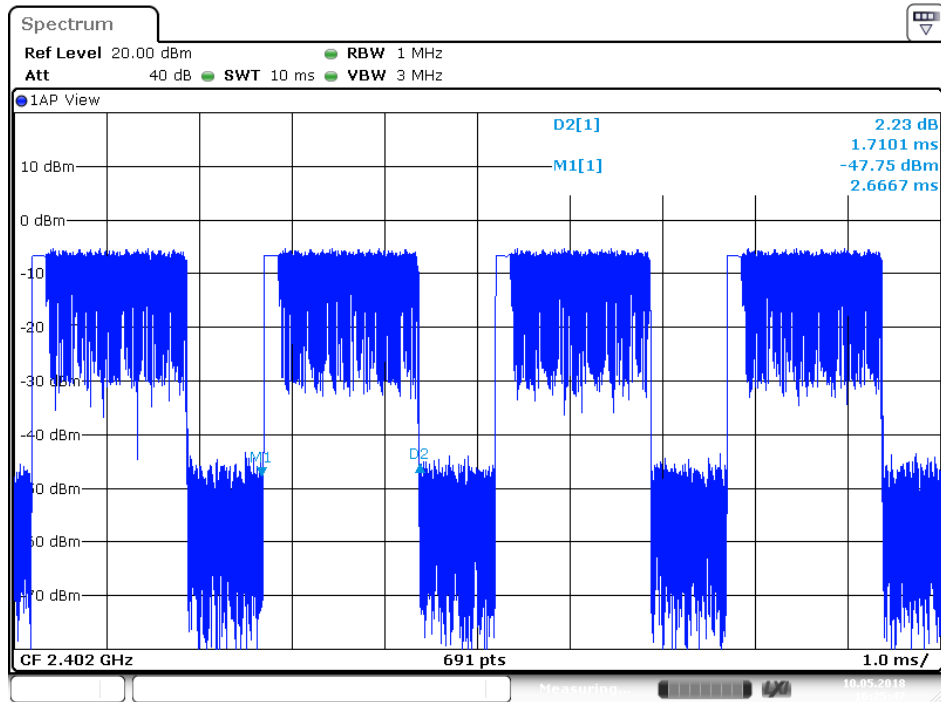

3DH3 Middle channel

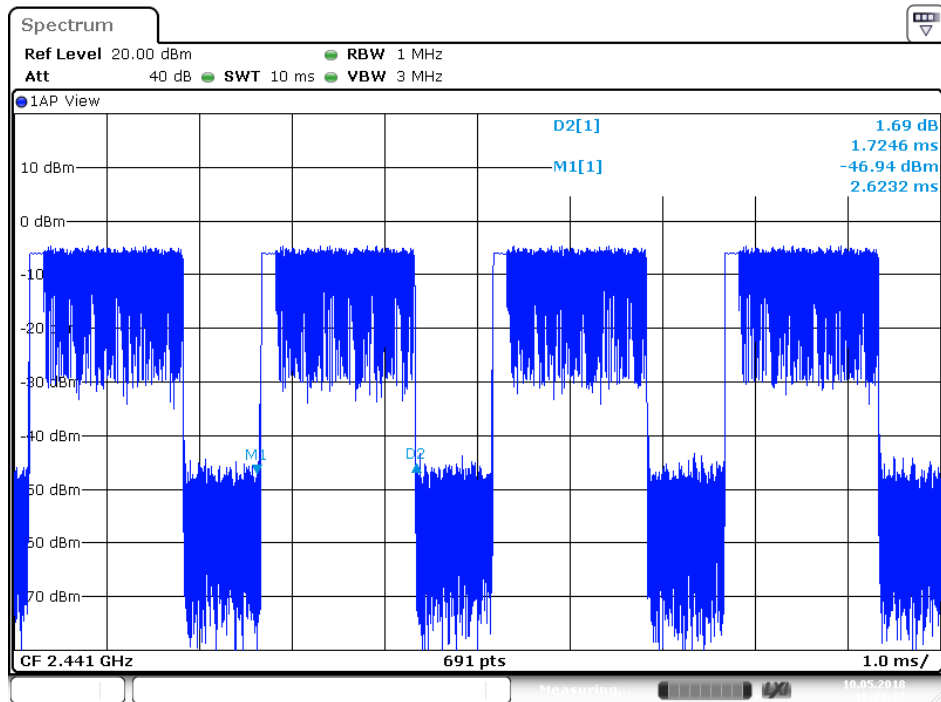

3DH3 High channel

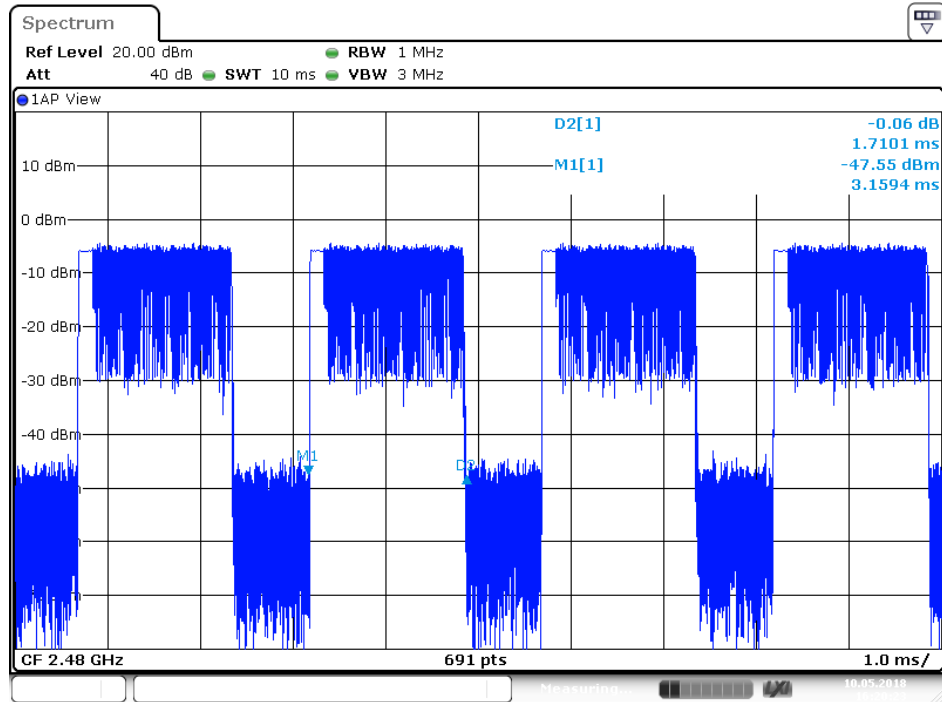

3DH5 Low channel

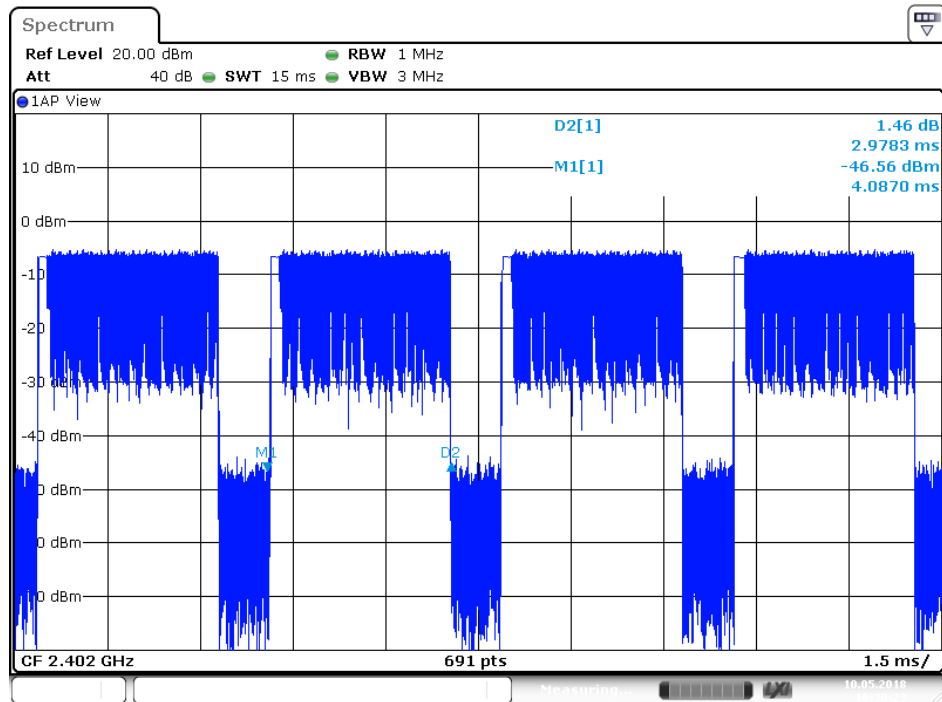

3DH5 Middle channel

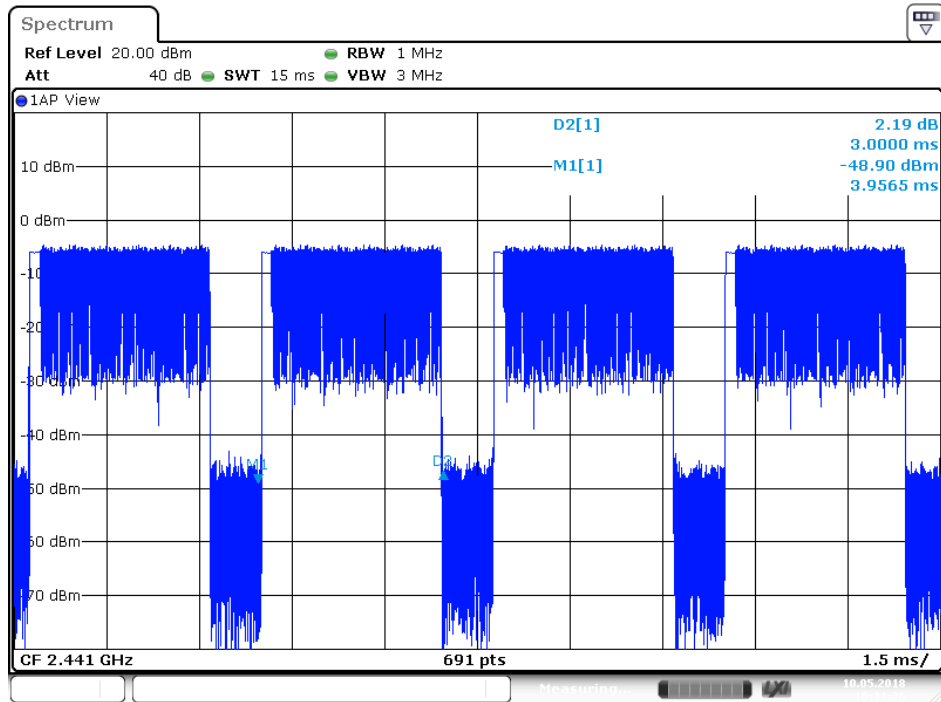

3DH5 High channel

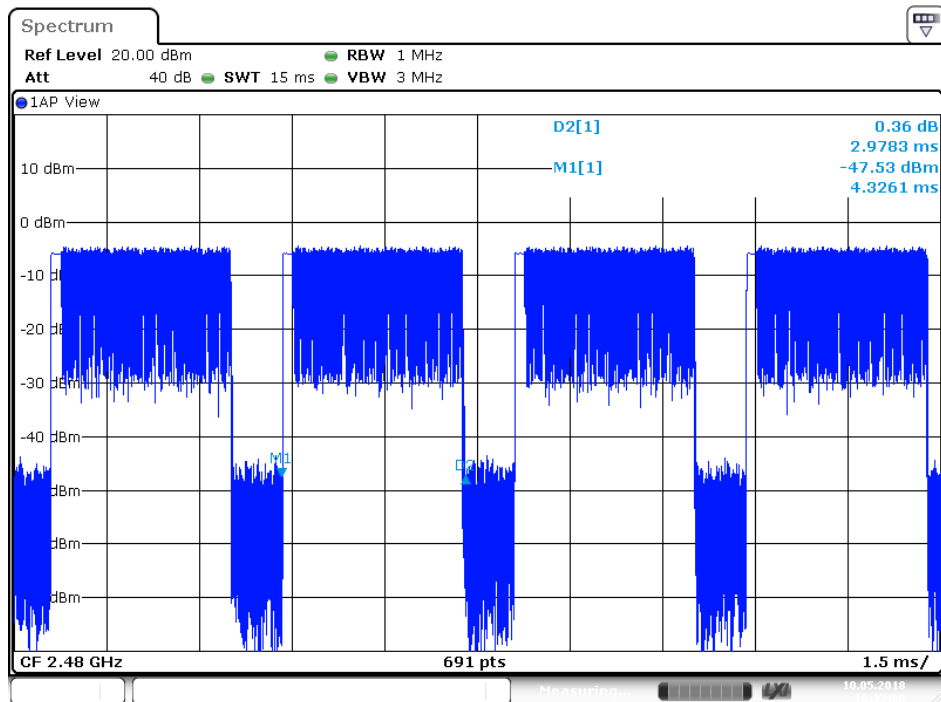

9. MAXIMUM PEAK OUTPUT POWER TEST

9.1. Block Diagram of Test Setup

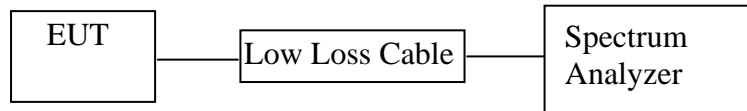

(EUT: ACTIVE SPEAKER SYSTEM)

9.2. The Requirement For Section 15.247(b)(1)

Section 15.247(b)(1): For frequency hopping systems operating in the 2400-2483.5 MHz band employing at least 75 non-overlapping hopping channels, and all frequency hopping systems in the 5725-5850 MHz band: 1 watt. For all other frequency hopping systems in the 2400-2483.5 MHz band: 0.125 watts.

9.3. The Requirement For RSS-247 Section 5.4(b)

RSS-247 Section 5.4(b): For FHSS operating in the band 2400-2483.5MHz, the maximum peak conducted output power shall not exceed 1.0 W if the hopset uses 75 or more hopping channels; the maximum peak conducted output power shall not exceed 0.125 W if the hopset uses less than 75 hopping channels.

The e.i.r.p. shall not exceed 4 W, except as provided in section 5.4(e).

9.4. EUT Configuration on Measurement

The equipment are installed on the emission Measurement to meet the commission requirements and operating regulations in a manner which tends to maximize its emission characteristics in normal application.

9.5. Operating Condition of EUT

9.5.1. Setup the EUT and simulator as shown as Section 9.1.

9.5.2. Turn on the power of all equipment.

9.5.3. Let the EUT work in TX (Hopping off) modes measure it. The transmit frequency are 2402-2480MHz. We select 2402MHz, 2441MHz, and 2480MHz TX frequency to transmit.

9.6. Test Procedure

9.6.1. The transmitter output was connected to the spectrum analyzer through a low loss cable.

9.6.2. Set RBW of spectrum analyzer to 1MHz and VBW to 3MHz for BDR mode

9.6.3. Set RBW of spectrum analyzer to 3MHz and VBW to 10MHz for EDR mode

9.6.4. Measurement the maximum peak output power.

9.7. Test Result

BDR Mode

Frequency (MHz)	Maximum peak conducted output power (dBm/W)	e.i.r.p. (dBm/W)	Limits dBm / W
2402	-2.20/0.00060	0.67/0.00117	30 / 1.0
2441	-1.59/0.00069	1.28/0.00134	30 / 1.0
2480	-1.42/0.00072	1.45/0.00140	30 / 1.0

EDR Mode

Frequency (MHz)	Maximum peak conducted output power (dBm/W)	e.i.r.p. (dBm/W)	Limits dBm / W
2402	1.37/0.00137	4.24/0.00265	21 / 0.125
2441	1.80/0.00151	4.67/0.00293	21 / 0.125
2480	1.97/0.00157	4.84/0.00305	21 / 0.125

Note: e.i.r.p= Maximum peak conducted output power+Antenna gain(2.87dBi)

The spectrum analyzer plots are attached as below.

BDR Mode

Low channel

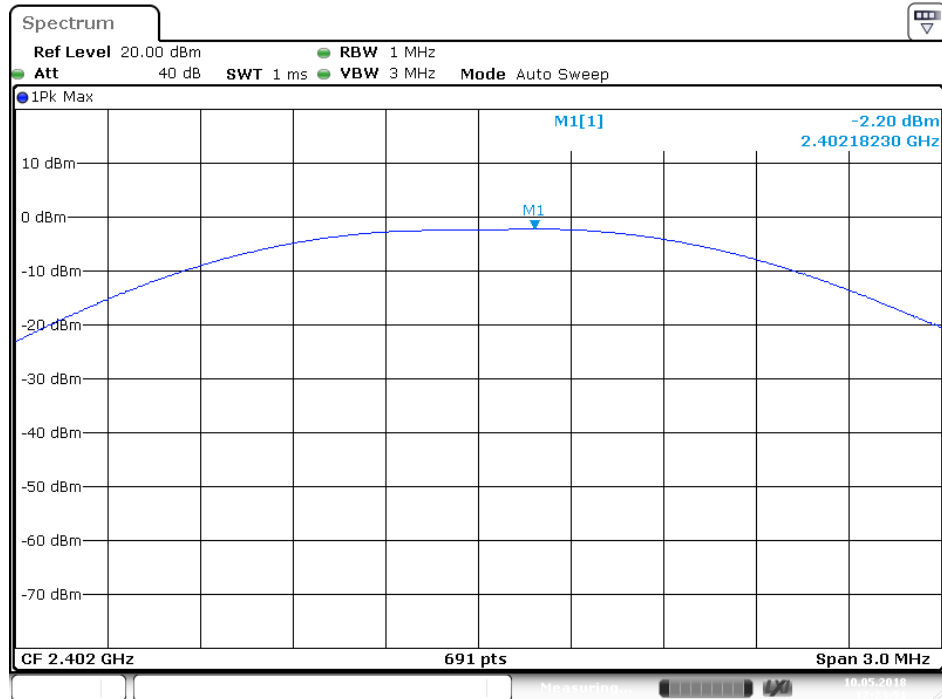

Date: 10.MAY.2018 17:23:51

Middle channel

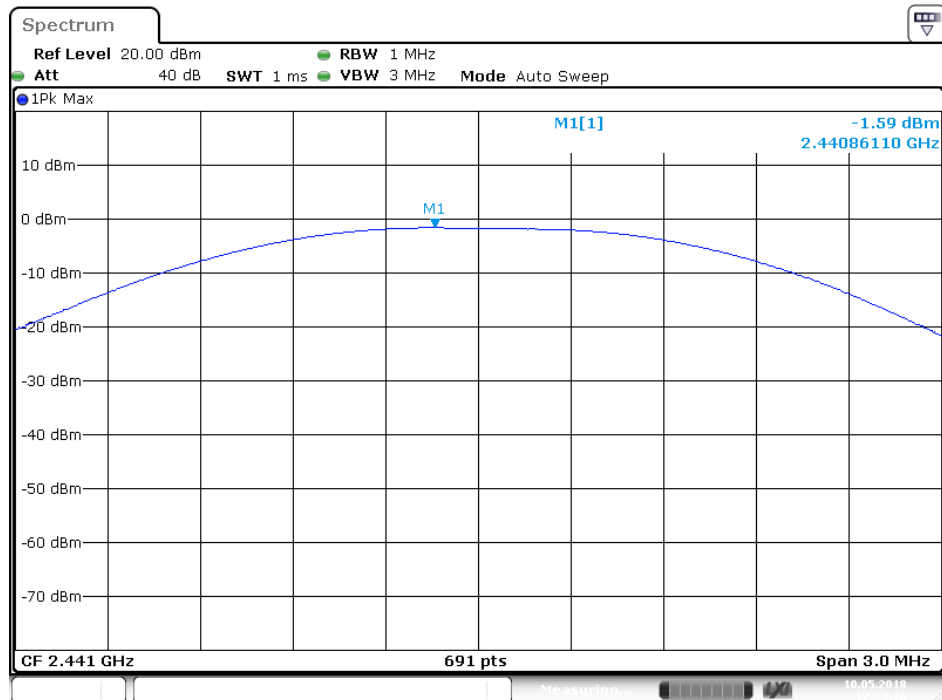

Date: 10.MAY.2018 17:23:10

High channel

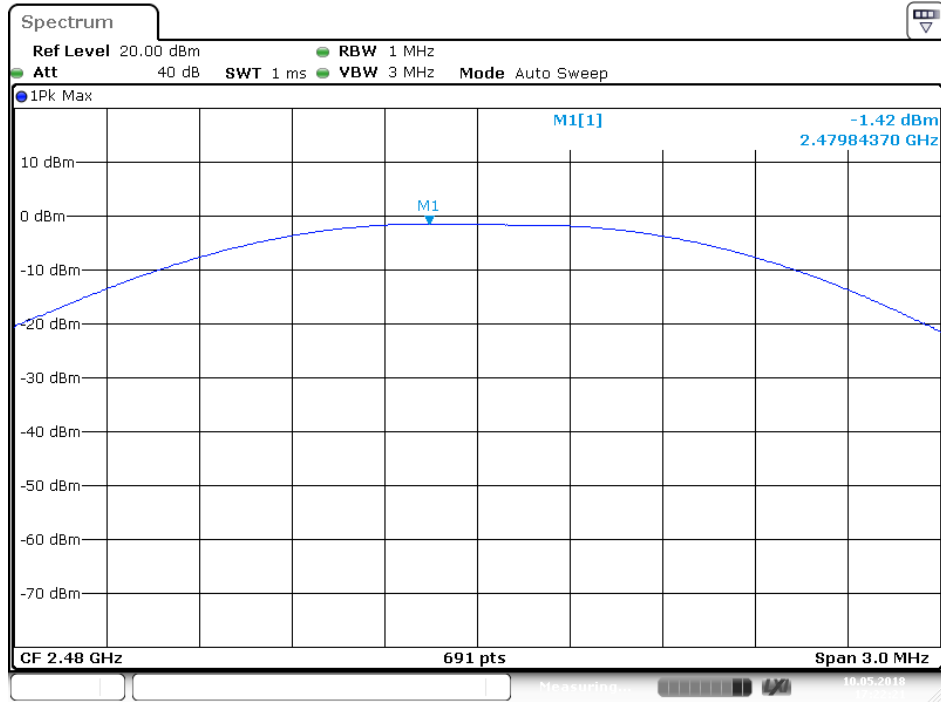

EDR Mode

Low channel

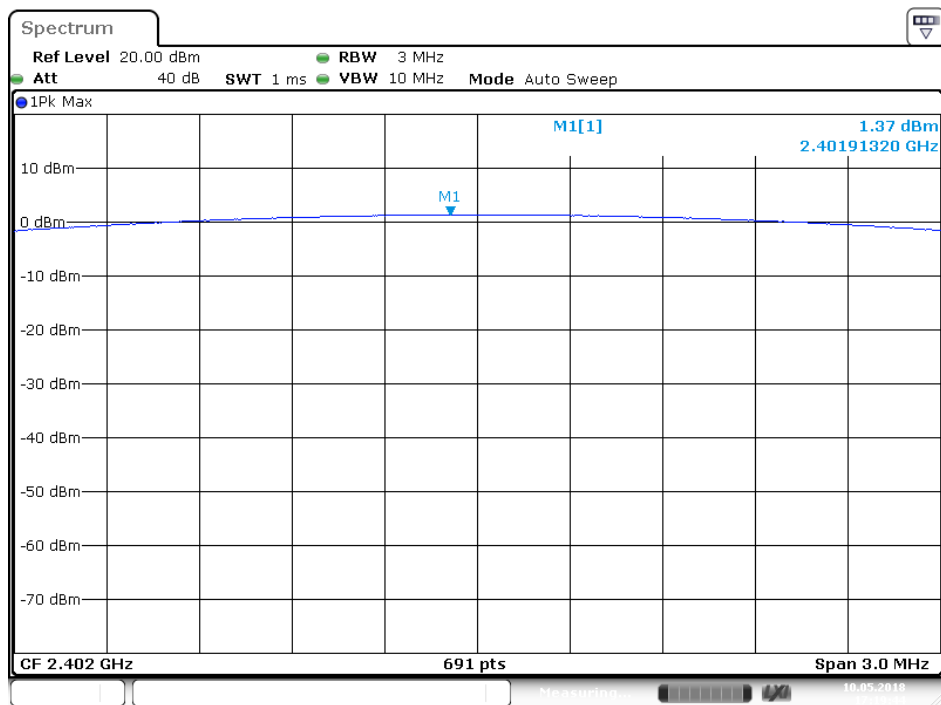

Middle channel

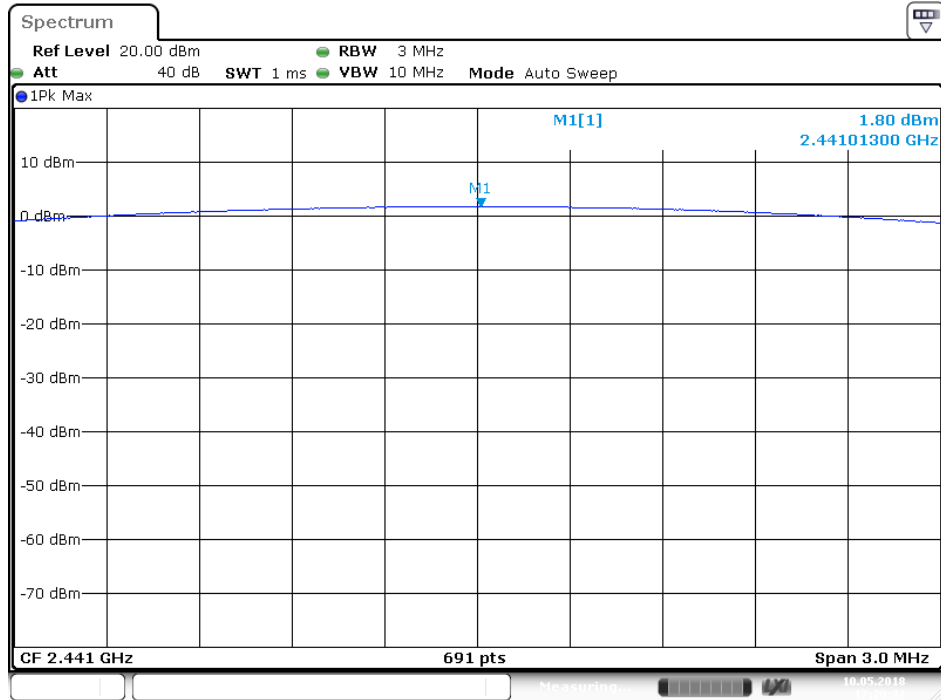

Date: 10.MAY.2018 17:20:33

High channel

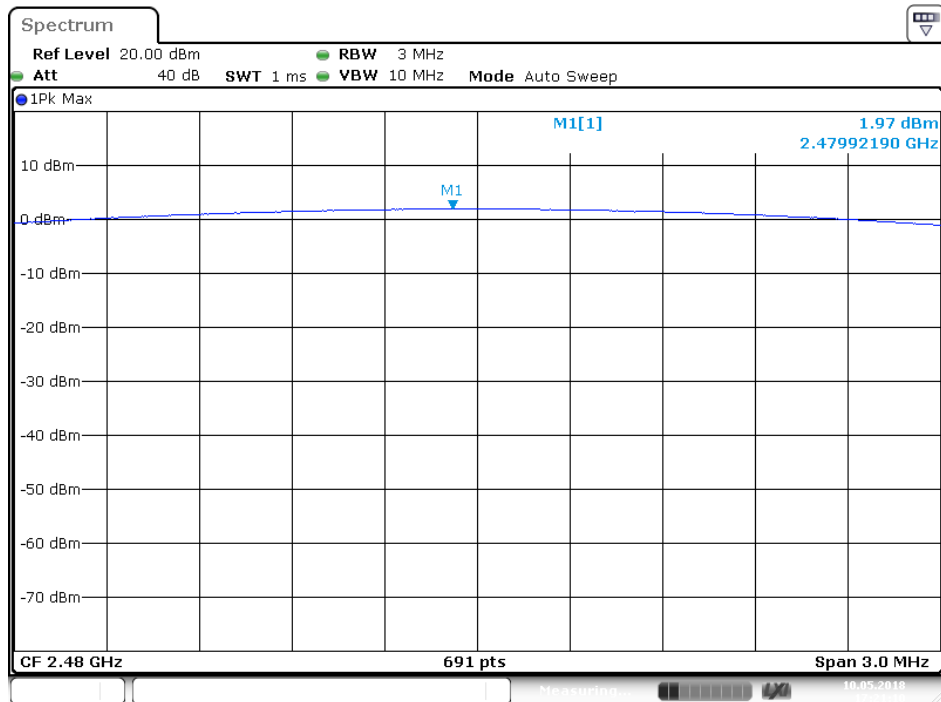

Date: 10.MAY.2018 17:21:10

10. RADIATED EMISSION TEST

10.1. Block Diagram of Test Setup

10.1.1. Block diagram of connection between the EUT and peripherals

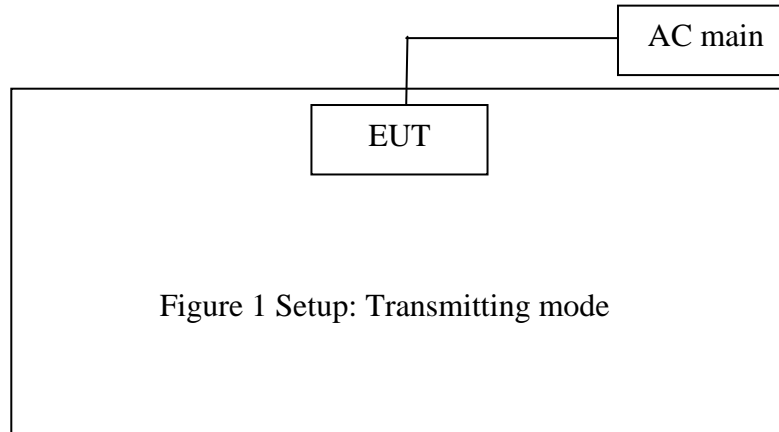

10.1.2. Semi-Anechoic Chamber Test Setup Diagram

(A) Radiated Emission Test Set-Up, Frequency below 30MHz

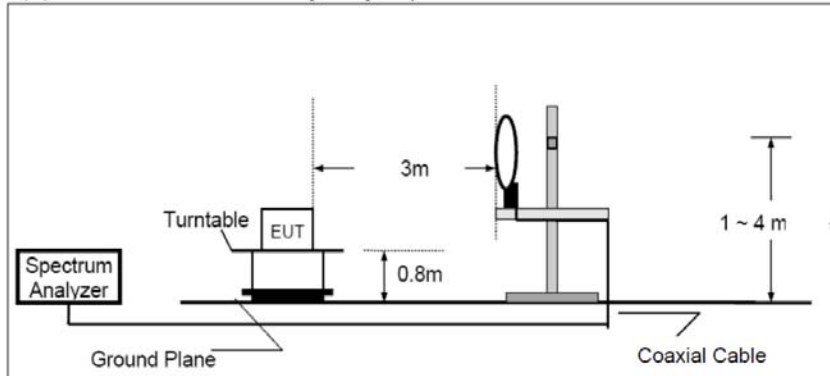

(B) Radiated Emission Test Set-Up, Frequency 30-1000MHz

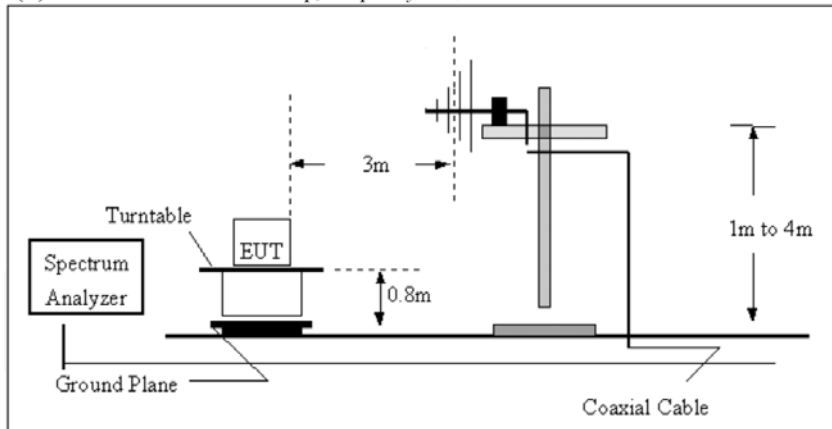

(C) Radiated Emission Test Set-Up, Frequency above 1GHz

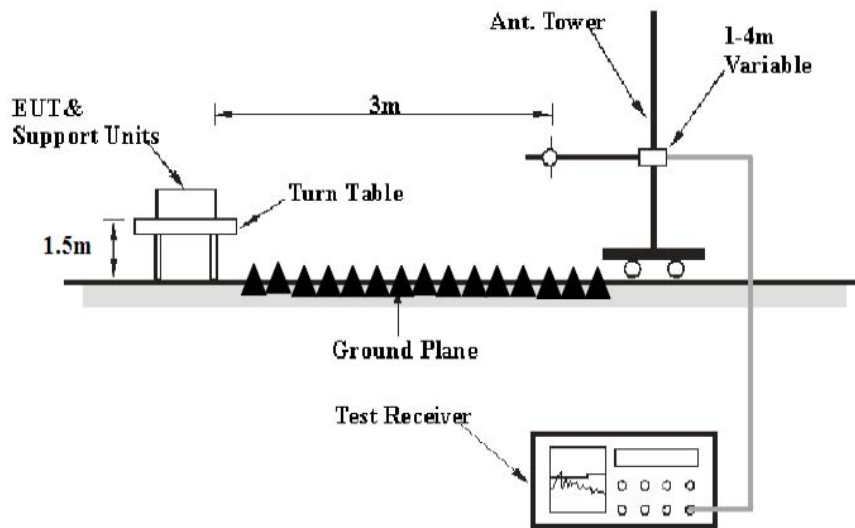

10.2. The Limit For Section 15.247(d)

Section 15.247(d): In any 100 kHz bandwidth outside the frequency band in which the spread spectrum or digitally modulated intentional radiator is operating, the radio frequency power that is produced by the intentional radiator shall be at least 20 dB below that in the 100 kHz bandwidth within the band that contains the highest level of the desired power, based on either an RF conducted or a radiated measurement, provided the transmitter demonstrates compliance with the peak conducted power limits. If the transmitter complies with the conducted power limits based on the use of RMS averaging over a time interval, as permitted under paragraph (b)(3) of this section, the attenuation required under this paragraph shall be 30 dB instead of 20 dB. Attenuation below the general limits specified in Section 15.209(a) is not required. In addition, radiated emissions which fall in the restricted bands, as defined in Section 15.205(a), must also comply with the radiated emission limits specified in Section 15.209(a).

10.3.Restricted bands of operation

10.3.1.FCC Part 15.205 Restricted bands of operation

(a) Except as shown in paragraph (d) of this section, Only spurious emissions are permitted in any of the frequency bands listed below:

MHz	MHz	MHz	GHz
0.090-0.110	16.42-16.423	399.9-410	4.5-5.15
¹ 0.495-0.505	16.69475-16.69525	608-614	5.35-5.46
2.1735-2.1905	16.80425-16.80475	960-1240	7.25-7.75
4.125-4.128	25.5-25.67	1300-1427	8.025-8.5
4.17725-4.17775	37.5-38.25	1435-1626.5	9.0-9.2
4.20725-4.20775	73-74.6	1645.5-1646.5	9.3-9.5
6.215-6.218	74.8-75.2	1660-1710	10.6-12.7
6.26775-6.26825	108-121.94	1718.8-1722.2	13.25-13.4
6.31175-6.31225	123-138	2200-2300	14.47-14.5
8.291-8.294	149.9-150.05	2310-2390	15.35-16.2
8.362-8.366	156.52475-156.52525	2483.5-2500	17.7-21.4
8.37625-8.38675	156.7-156.9	2690-2900	22.01-23.12
8.41425-8.41475	162.0125-167.17	3260-3267	23.6-24.0
12.29-12.293	167.72-173.2	3332-3339	31.2-31.8
12.51975-12.52025	240-285	3345.8-3358	36.43-36.5
12.57675-12.57725	322-335.4	3600-4400	(²)
13.36-13.41			

¹Until February 1, 1999, this restricted band shall be 0.490-0.510

²Above 38.6

(b) Except as provided in paragraphs (d) and (e), the field strength of emission appearing within these frequency bands shall not exceed the limits shown in Section 15.209. At frequencies equal to or less than 1000MHz, Compliance with the limits in Section 15.209 shall be demonstrated using measurement instrumentation employing a CISPR quasi-peak detector. Above 1000MHz, compliance with the emission limits in Section 15.209 shall be demonstrated based on the average value of the measured emissions. The provisions in Section 15.35 apply to these measurements.

10.4.Configuration of EUT on Measurement

The equipment is installed on Radiated Emission Measurement to meet the commission requirements and operating regulations in a manner which tends to maximize its emission characteristics in normal application.

10.5. Test Procedure

The EUT and its simulators are placed on a turntable, which is 0.8 meter high above ground (Below 1GHz). The EUT and its simulators are placed on a turntable, which is 1.5 meter high above ground (Above 1GHz). The turntable can rotate 360 degrees to determine the position of the maximum emission level. EUT is set 3.0 meters away from the receiving antenna, which is mounted on an antenna tower. The antenna can be moved up and down between 1.0 meter and 4 meters to find out the maximum emission level. Broadband antenna (calibrated bi-log antenna) is used as receiving antenna. Both horizontal and vertical polarizations of the antenna are set on measurement. In order to find the maximum emission levels, all of the EUT location must be manipulated according to ANSI C63.10:2013 on radiated emission measurement. The EUT was tested in 3 orthogonal planes.

During the radiated emission test, the spectrum analyzer was set with the following configurations:

1. The resolution bandwidth and video bandwidth of test receiver/spectrum analyzer is 120kHz for Quasi-peak at frequency below 1GHz.
2. The resolution bandwidth of test receiver/spectrum analyzer is 1MHz and video bandwidth is 3MHz for peak measurement with peak detector at frequency above 1GHz.
3. The resolution bandwidth of test receiver/spectrum analyzer is 1MHz and video bandwidth is 10Hz for Average measurement with peak detection at frequency above 1GHz.
4. All modes of operation were investigated and the worst-case emissions are reported.

10.6. Data Sample

Frequency (MHz)	Reading (dB μ v)	Factor (dB/m)	Result (dB μ v/m)	Limit (dB μ v/m)	Margin (dB)	Remark
X.XX	48.69	-13.35	35.34	46	-10.66	QP

Frequency(MHz) = Emission frequency in MHz

Reading(dB μ v) = Uncorrected Analyzer/Receiver reading

Factor (dB/m) = Antenna factor + Cable Loss – Amplifier gain

Result(dB μ v/m) = Reading(dB μ v) + Factor(dB/m)

Limit (dB μ v/m) = Limit stated in standard

Margin (dB) = Result(dB μ v/m) - Limit (dB μ v/m)

QP = Quasi-peak Reading

Calculation Formula:

Margin(dB) = Result (dB μ V/m)–Limit(dB μ V/m)

Result(dB μ V/m)= Reading(dB μ V)+ Factor(dB/m)

The “Margin” column of the following data tables indicates the degree of compliance with the applicable limit. For example, a margin of -7dB means the emission is 7dB below the limit.

10.7.The Field Strength of Radiation Emission Measurement Results

Note: 1.We tested GFSK mode, $\Pi/4$ -DQPSK Mode & 8QPSK mode and recorded the worst case data (EDR mode) for all test mode.

9kHz-30MHz test data

ACCURATE TECHNOLOGY CO., LTD

FCC Class B 3M Radiated

EUT: ACTIVE SPEAKER SYSTEM M/N:A100
 Manufacturer: Dongguan Platinum Audio Systems Co., Ltd.
 Operating Condition: TX 2402MHz
 Test Site: 2# Chamber
 Operator: WADE
 Test Specification: AC 120V/60Hz
 Comment: X
 Start of Test: 2018-5-10 /

SCAN TABLE: "LFRE Fin"

Short Description:			SUB STD VTERM2 1.70			
Start Frequency	Stop Frequency	Step Width	Detector	Meas. Time	IF Bandw.	Transducer
9.0 kHz	150.0 kHz	100.0 Hz	QuasiPeak	1.0 s	200 Hz	1516M
150.0 kHz	30.0 MHz	5.0 kHz	QuasiPeak	1.0 s	9 kHz	1516M

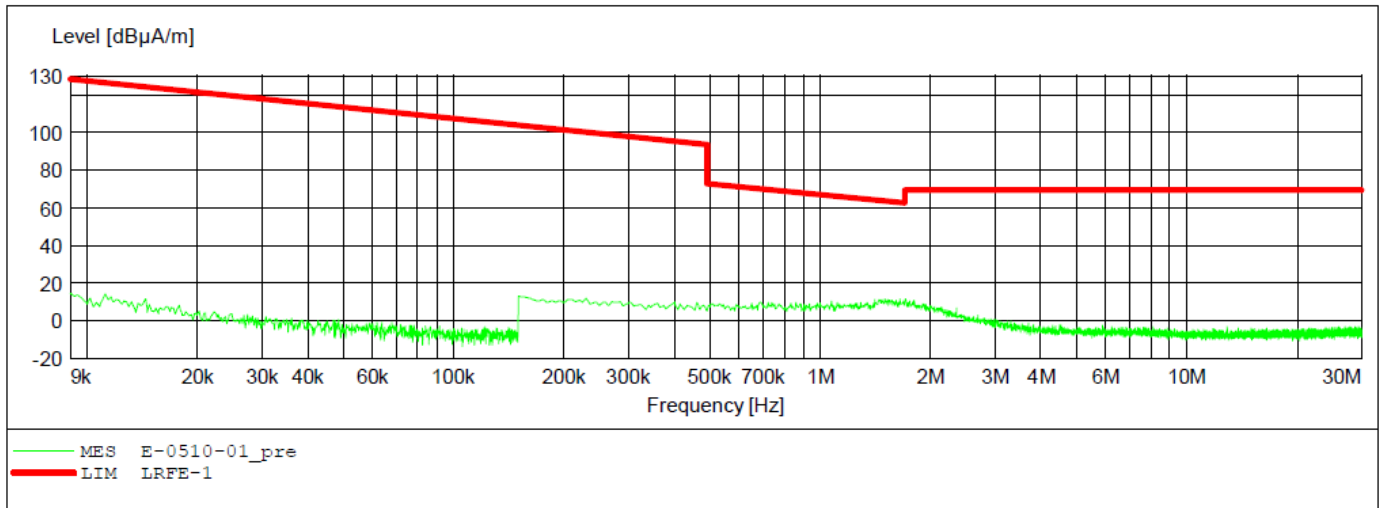

ACCURATE TECHNOLOGY CO., LTD

FCC Class B 3M Radiated

EUT: ACTIVE SPEAKER SYSTEM M/N:A100
 Manufacturer: Dongguan Platinum Audio Systems Co., Ltd.
 Operating Condition: TX 2402MHz
 Test Site: 2# Chamber
 Operator: WADE
 Test Specification: AC 120V/60Hz
 Comment: Y
 Start of Test: 2018-5-10 /

SCAN TABLE: "LFRE Fin"

Short Description:			SUB STD VTERM2 1.70			
Start	Stop	Step	Detector	Meas.	IF	Transducer
Frequency	Frequency	Width		Time	Bandw.	
9.0 kHz	150.0 kHz	100.0 Hz	QuasiPeak	1.0 s	200 Hz	1516M
150.0 kHz	30.0 MHz	5.0 kHz	QuasiPeak	1.0 s	9 kHz	1516M

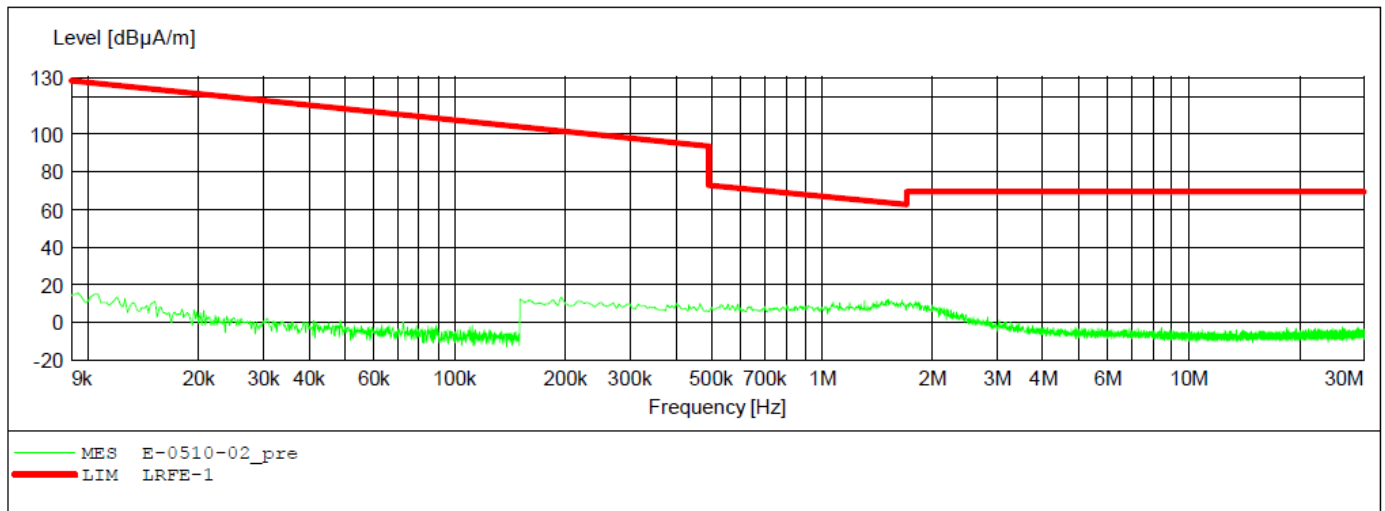

ACCURATE TECHNOLOGY CO., LTD

FCC Class B 3M Radiated

EUT: ACTIVE SPEAKER SYSTEM M/N:A100
 Manufacturer: Dongguan Platinum Audio Systems Co., Ltd.
 Operating Condition: TX 2402MHz
 Test Site: 2# Chamber
 Operator: WADE
 Test Specification: AC 120V/60Hz
 Comment: Z
 Start of Test: 2018-5-10 /

SCAN TABLE: "LRFE Fin"

Short Description:			SUB STD VTERM2 1.70			
Start Frequency	Stop Frequency	Step Width	Detector	Meas. Time	IF Bandw.	Transducer
9.0 kHz	150.0 kHz	100.0 Hz	QuasiPeak	1.0 s	200 Hz	1516M
150.0 kHz	30.0 MHz	5.0 kHz	QuasiPeak	1.0 s	9 kHz	1516M

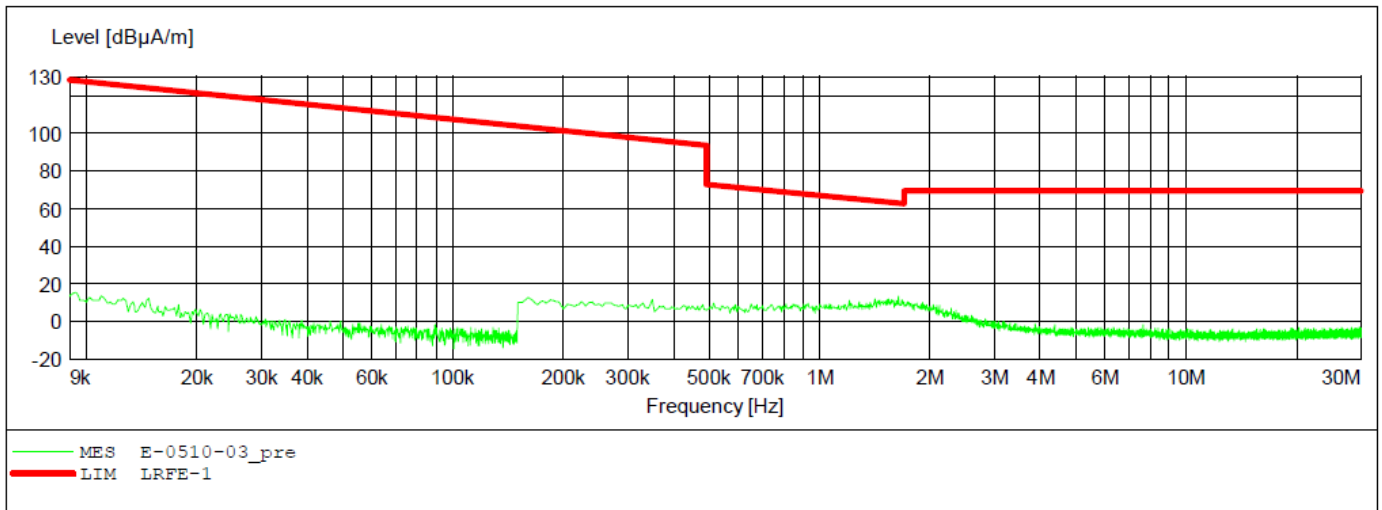

ACCURATE TECHNOLOGY CO., LTD

FCC Class B 3M Radiated

EUT: ACTIVE SPEAKER SYSTEM M/N:A100
 Manufacturer: Dongguan Platinum Audio Systems Co., Ltd.
 Operating Condition: TX 2441MHz
 Test Site: 2# Chamber
 Operator: WADE
 Test Specification: AC 120V/60Hz
 Comment: X
 Start of Test: 2018-5-10 /

SCAN TABLE: "LFRE Fin"

Short Description:			SUB STD VTERM2 1.70			
Start Frequency	Stop Frequency	Step Width	Detector	Meas. Time	IF Bandw.	Transducer
9.0 kHz	150.0 kHz	100.0 Hz	QuasiPeak	1.0 s	200 Hz	1516M
150.0 kHz	30.0 MHz	5.0 kHz	QuasiPeak	1.0 s	9 kHz	1516M

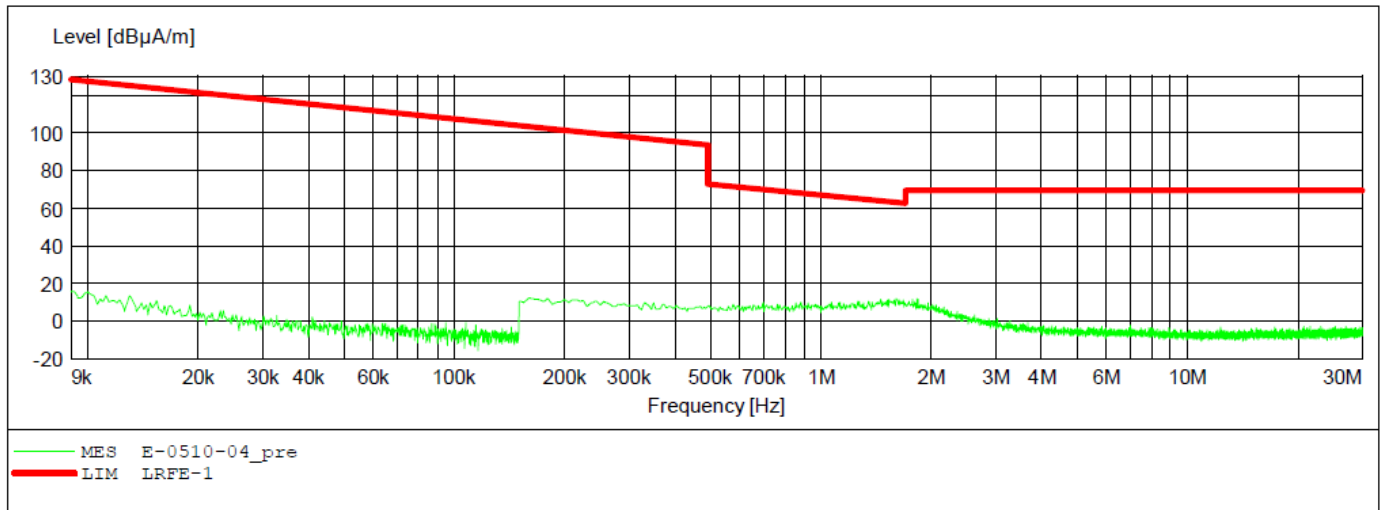

ACCURATE TECHNOLOGY CO., LTD

FCC Class B 3M Radiated

EUT: ACTIVE SPEAKER SYSTEM M/N:A100
 Manufacturer: Dongguan Platinum Audio Systems Co., Ltd.
 Operating Condition: TX 2441MHz
 Test Site: 2# Chamber
 Operator: WADE
 Test Specification: AC 120V/60Hz
 Comment: Y
 Start of Test: 2018-5-10 /

SCAN TABLE: "LFRE Fin"

Short Description:			SUB STD VTERM2 1.70			
Start	Stop	Step	Detector	Meas. Time	IF Bandw.	Transducer
Frequency	Frequency	Width				
9.0 kHz	150.0 kHz	100.0 Hz	QuasiPeak	1.0 s	200 Hz	1516M
150.0 kHz	30.0 MHz	5.0 kHz	QuasiPeak	1.0 s	9 kHz	1516M

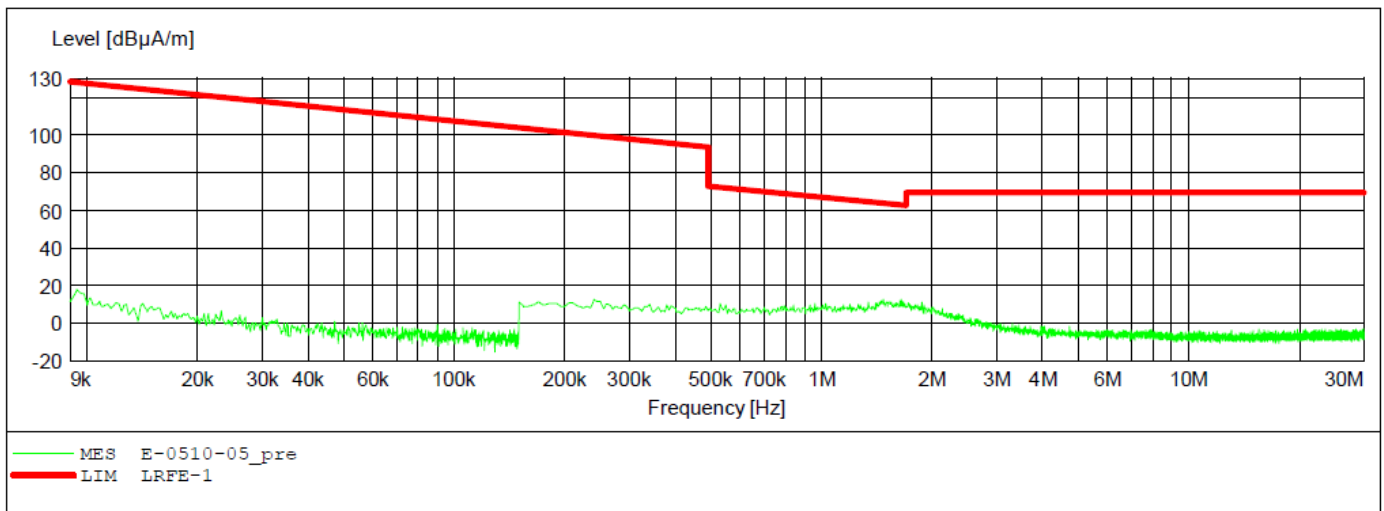

ACCURATE TECHNOLOGY CO., LTD

FCC Class B 3M Radiated

EUT: ACTIVE SPEAKER SYSTEM M/N:A100
 Manufacturer: Dongguan Platinum Audio Systems Co., Ltd.
 Operating Condition: TX 2441MHz
 Test Site: 2# Chamber
 Operator: WADE
 Test Specification: AC 120V/60Hz
 Comment: Z
 Start of Test: 2018-5-10 /

SCAN TABLE: "LFRE Fin"

Short Description:			SUB STD VTERM2 1.70			
Start	Stop	Step	Detector	Meas. Time	IF Bandw.	Transducer
Frequency	Frequency	Width				
9.0 kHz	150.0 kHz	100.0 Hz	QuasiPeak	1.0 s	200 Hz	1516M
150.0 kHz	30.0 MHz	5.0 kHz	QuasiPeak	1.0 s	9 kHz	1516M

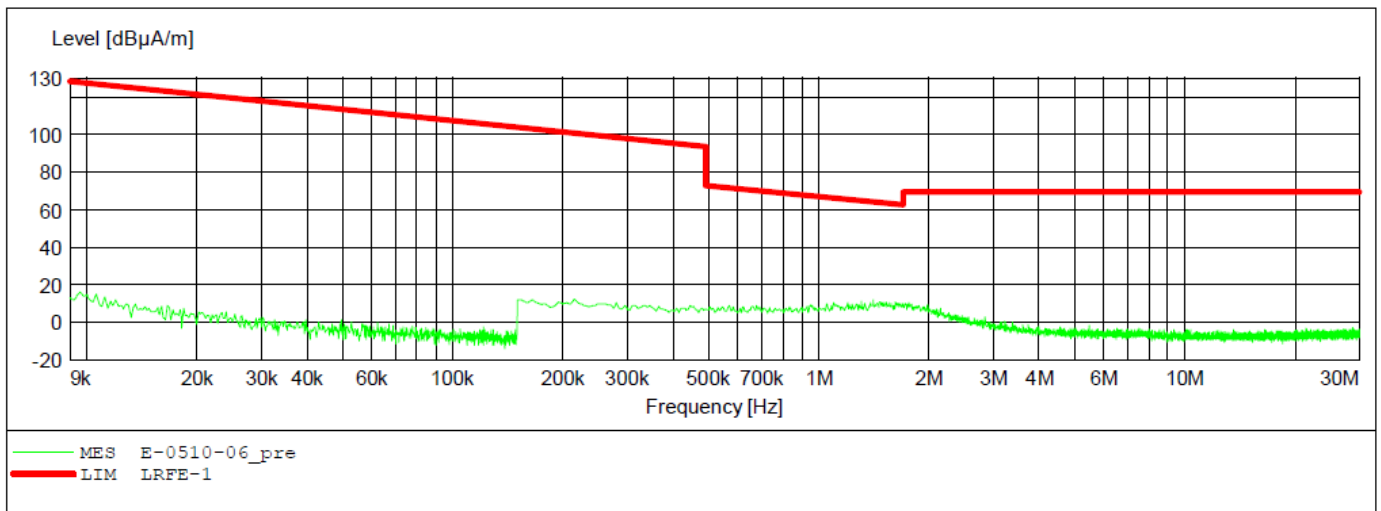

ACCURATE TECHNOLOGY CO., LTD

FCC Class B 3M Radiated

EUT: ACTIVE SPEAKER SYSTEM M/N:A100
 Manufacturer: Dongguan Platinum Audio Systems Co., Ltd.
 Operating Condition: TX 2480MHz
 Test Site: 2# Chamber
 Operator: WADE
 Test Specification: AC 120V/60Hz
 Comment: X
 Start of Test: 2018-5-10 /

SCAN TABLE: "LFRE Fin"

Short Description:			SUB STD VTERM2 1.70			
Start Frequency	Stop Frequency	Step Width	Detector	Meas. Time	IF Bandw.	Transducer
9.0 kHz	150.0 kHz	100.0 Hz	QuasiPeak	1.0 s	200 Hz	1516M
150.0 kHz	30.0 MHz	5.0 kHz	QuasiPeak	1.0 s	9 kHz	1516M

