

EDIFIER

FCC Statement

This device complies with part 15 of the FCC Rules. Operation is subject to the following two conditions:

- (1) This device may not cause harmful interference, and
- (2) This device must accept any interference received, including interference that may cause undesired operation.

Any Changes or modifications not expressly approved by the party responsible for compliance could void the user's authority to operate the equipment.

Note: This equipment has been tested and found to comply with the limits for a Class B digital device, pursuant to part 15 of the FCC Rules. These limits are designed to provide reasonable protection against harmful interference in a residential installation. This equipment generates uses and can radiate radio frequency energy and, if not installed and used in accordance with the instructions, may cause harmful interference to radio communications.

However, there is no guarantee that interference will not occur in a particular installation. If this equipment does cause harmful interference to radio or television reception, which can be determined by turning the equipment off and on, the user is encouraged to try to correct the interference by one or more of the following measures:

- Reorient or relocate the receiving antenna.
- Increase the separation between the equipment and receiver.
- Connect the equipment into an outlet on a circuit different from that to which the receiver is connected.
- Consult the dealer or an experienced radio/TV technician for help.

This equipment complies with FCC radiation exposure limits set forth for an uncontrolled environment. This equipment should be installed and operated with minimum distance 20cm between the radiator & your body.

IC Caution

The device meets the exemption from the routine evaluation limits in section 2.5 of RSS 102 and compliance with RSS-102 RF exposure, users can obtain Canadian information on RF exposure and compliance.

This device complies with Industry Canada licence-exempt RSS standard(s). Operation is subject to the following two conditions:

- (1) This device may not cause interference, and
- (2) This device must accept any interference, including interference that may cause undesired operation of the device.

This equipment should be installed and operated with a minimum distance of 20 cm between the radiator and your body.

Le dispositif rencontre l'exemption des limites courantes d'évaluation dans la section 2.5 de RSS102 et la conformité à l'exposition de RSS-102 rf, utilisateurs peut obtenir l'information canadienne sur l'exposition et la conformité de rf. Le present appareil est conforme aux CNR d'Industrie Canada applicables aux appareils radio exempts de licence. L'exploitation est autorisée aux deux conditions suivantes:

- (1) l'appareil ne doit pas produire de brouillage, et
- (2) l'utilisateur de l'appareil doit accepter tout brouillage radioélectrique subi, même si le brouillage est susceptible d'en compromettre le fonctionnement.

Cet équipement doit être installé et utilisé à une distance minimale de 20 cm entre le radiateur et votre corps.

IB-200-000000-05

名 称:	说明书FCC认证说明		东莞市漫步者科技有限公司
材 质:	80g书纸	版面设计:	
尺 寸:	125 × 120 (MM)	校 对:	
版本号及料号:	V1. 1/IB-200-000000-05	批 准:	

M2280BT

Multimedia Speaker

Suit 2207, 22nd floor,
Tower II, Lippo centre,
89 Queensway
Hong Kong

Tel: +852 2522 6989
Fax: +852 2522 1989
www.edifier.com
© 2017 Edifier International Limited. All rights reserved.
Printed in China

NOTICE:
For the need of technical improvement and system upgrade, information contained herein may be subject to change from time to time without prior notice.
Products of EDIFIER will be customized for different applications. Pictures and illustrations shown on this manual may be slightly different from actual product. If any difference is found, the actual product prevails.

User manual | Manuel d'utilisateur | Manual de usuario | Bedienungsanleitung |
Manuale dell'utente | Manual do utilizador

Important safety instruction

1. Please read the instructions carefully. Keep it in safe place for future reference.
2. Use only accessories approved by the manufacturer.
3. Install the instrument properly by following the instructions in the device connection section.
4. Using the product in a 0-35 °C environment is recommended.
5. To reduce the risk of fire and electric shock, do not expose the product to rain or moisture.
6. Do not use this product near water. Do not immerse the product into any liquid or have it exposed to dripping or splashing.
7. Do not install or use this product near any heat source (e.g. radiator, heater, stove, or other devices that generate heat).
8. Do not place any object filled with liquids, such as vases on the product; neither should any open fire, such as lighted candles be placed on the product.
9. Do not block any ventilation openings. Do not insert any object into ventilation openings or slots. It may cause fire or electric shock.
10. Keep sufficient clearance around the product to maintain good ventilation (minimum 5cm is recommended).
11. Do not force a plug into the jack. Before connection, check for blockage in the jack and whether the plug matches the jack and is oriented to the right direction.
12. Keep the provided accessories and parts (such as screws) away from children to prevent from being swallowed by mistake.
13. Do not open or remove the housing yourself. It may expose you to dangerous voltage or other hazardous risks. Regardless the cause of damage (such as damaged wire or plug, exposure to liquid splash or foreign object falling in, exposure to rain or moisture, product not working or being dropped, etc.), the repair has to be performed by an authorized service professional immediately.
14. Before cleaning the product with dry cloth, always turn off the product and disconnect the power plug first.
15. Never use strong acid, alkali, gasoline, alcohol, or other chemical solvents to clean the product surface. Use only neutral solvent or clear water for cleaning.

Excessively loud music may lead to hearing loss. Please keep the volume in a safe range.

Correct Disposal of this product. This marking indicates that this product should not be disposed with other household wastes throughout the EU. To prevent possible harm to the environment or human health from uncontrolled waste disposal, recycle it responsibly to promote the sustainable reuse of material resources. To return your used device, please use the return and collection systems or contact the retailer where the product was purchased. They can take this product for environmental safe recycling.

Use only with the cart, stand, tripod, bracket, or table specified by the manufacturer, or sold with the apparatus. When a cart is used, use caution when moving the cart/apparatus combination to avoid injury from tip-over.

1
English

Important safety instruction

Power warning:

1. Place the product near the power outlet.
2. Before use, make sure that the operating voltage is the same as your local power supply. Correct operating voltage can be found on the product plate.
3. For safety purpose, unplug the product during lightning storms or when unused for extended periods of time.
4. Under normal conditions, the power supply may get hot. Please keep good ventilation in the area and exercise caution.
5. Safety warning labels on the housing or bottom of the product or power adaptor.

This symbol is to alert the user to the presence of un-insulated dangerous voltage within the product's enclosure that may be of sufficient magnitude to constitute a risk of electric shock to persons.

This symbol is to warn the user not to disassemble the enclosure of the product and there is no user-replaceable part inside. Take the product to an authorized service center for repair.

This symbol indicates that the product is for indoor use only.

This symbol indicates that the product is a CLASS II or double insulated electrical device with no earth requirement.

Products with grounding pin shall be connected to a power outlet with earth protection. For devices with detachable power cord, the product can be easily disconnected from the wire coupler. For devices without detachable power cord, unplug the product from wall socket to disconnect. For products equipped with all-pole mains switch, use the power switch as the disconnection device.

For wireless product:

1. Wireless product may generate shortwave radio frequencies and interfere with the normal use of other electronic devices or medical equipment.
2. Turn off the product when it's disallowed. Do not use the product in medical facilities, on airplane, at gas stations, near automatic gates, automatic fire alarm system or other automated devices.
3. Do not use the product in the vicinity of a pacemaker within a 20cm range. The radio waves may affect the normal operation of the pacemaker or other medical devices.

2
English

What's In The Box

Box Contents

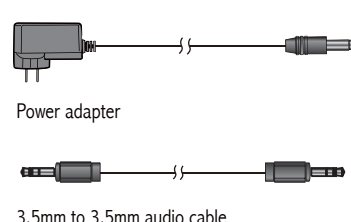

3
English

Illustration

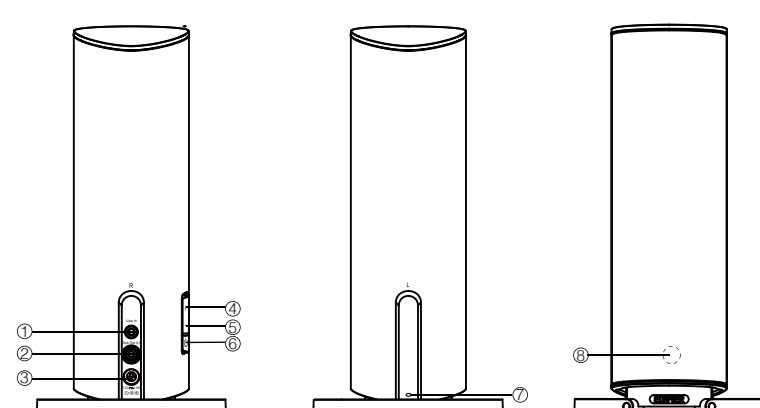

1. Line in input
2. Left sound channel output
3. Power input
4. Volume up
5. Press: volume down
Press and hold: disconnect Bluetooth (Bluetooth mode)

6. Press: mode switching AUX-Bluetooth
Press and hold: Standby/Power ON
7. Connect to active speaker
8. LED indicator
Green: AUX mode
Blue: Bluetooth mode

4
English

Connection

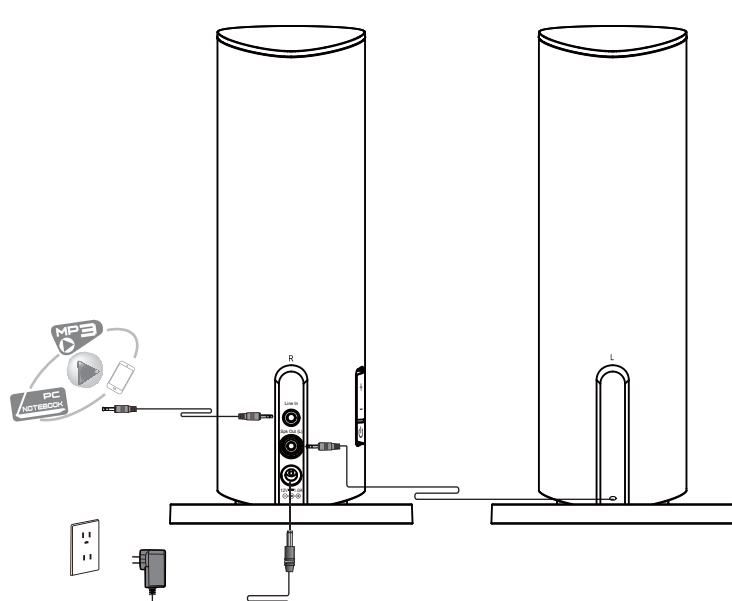

5
English

Basic operation

Connecting speakers

Connect speakers based on the connection illustration.

Connect to audio source

1. Connect audio source (such as mobile phone, tablet etc) to Line in input on the active speaker rear panel using 3.5mm to 3.5mm audio cable.
2. Press the "U" button on the active speaker side panel to select AUX mode, LED indicator will turn green.
3. Play music and adjust to the desired volume.

Power ON/Standby

1. When playing, press and hold the "U" button on the active speaker side panel for about 2 seconds to enter standby mode, the indicator will turn off;
2. Press the "U" button again to power on the speaker, the indicator is now lit.

6
English

Bluetooth operation

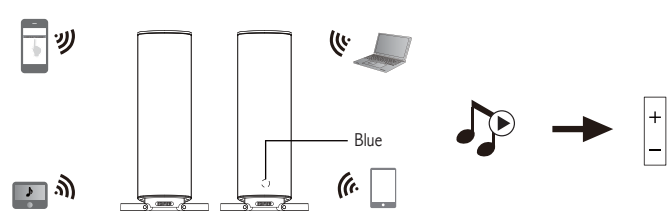

1. Press the "U" button on the active speaker side panel to select Bluetooth mode, LED indicator will turn blue.
2. Turn on your Bluetooth device to search for and connect to "EDIFIER M2280BT".

Note:
* M2280BT Bluetooth can only be searched and connected in Bluetooth mode; the existing Bluetooth connection will be disconnected once the speaker is switched into other mode; when the speaker switched back to Bluetooth mode, the speaker will try to connect to the last connected Bluetooth audio source device.
* Pin code for connection is "0000" if it is needed.
* To disconnect Bluetooth, press and hold the "U" button on the active speaker side panel for about 2 seconds
* To enjoy all Bluetooth functions of this product, please ensure your mobile device has A2DP profile.
* Bluetooth connectivity and compatibility may be different between different source devices, depending on the software versions of source devices.

7
English

Specification

Power output:	R/L: 6W+6W
Frequency response:	150Hz~20KHz
Noise level:	≤ 30dB(A)
Sensitivity:	AUX: R/L: 700±50mV Bluetooth: R/L: 700±50mV
Tweeter unit:	2 3/4 inch (70mm)
Input type:	AUX/Bluetooth
Frequency Band:	2.402GHz~2.480GHz
RF Power output:	≤ 20 dBm (EIRP)

There are no restrictions of use.

8
English

Troubleshooting

Problem	Solution
No sound	<ul style="list-style-type: none"> • Check if the power indicator light is ON • Try to turn up the volume using either the master volume control or remote control. • Ensure the audio cables are firmly connected and the input is set correctly on the speakers. • Check if there is a signal output from the audio source.
Cannot connect via Bluetooth	<ul style="list-style-type: none"> • Make sure the speaker is switched to Bluetooth input. If it is in other audio input modes, Bluetooth will not connect. Disconnect from any Bluetooth device by pressing and holding the volume dial in Bluetooth mode, then try again. • Effective Bluetooth transmission range is 10 meters; please ensure that operation is within the range. • Try another Bluetooth device for connection.
The M2280BT does not turn on	<ul style="list-style-type: none"> • Check if main power is connected, or if the wall outlet is switched on.

To learn more about EDIFIER, please visit www.edifier.com
For Edifier warranty queries, please visit the relevant country page on www.edifier.com and review the section titled Warranty Terms.
USA and Canada: service@edifier.ca
South America: Please visit www.edifier.com (English) or www.edifierla.com (Spanish/Portuguese) for local contact information.

9
English