

**红色线框为折线, 不印刷

EDIFIER®

D32
 Tabletop Wireless Speaker

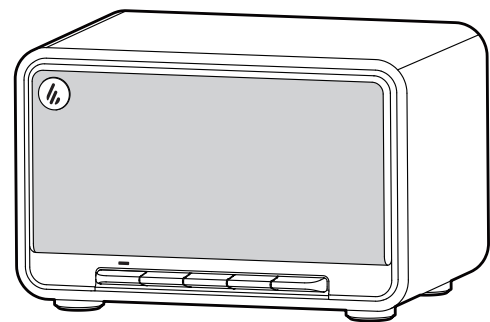

— Quick Start Guide — (BC)

Manual Edition 1.0, January 2024
 IB-200-D00320-00

For more information, please visit our website:

www.edifier.com



@Edifierglobal @Edifier_Global @Edifier_Global

EDIFIER ConneX app



Model: EDF100080
 FCC ID: Z9G-EDF227
 IC: 10004A-EDF227

Edifier International Limited
 P.O. Box 6264
 General Post Office
 Hong Kong

Tel: +852 2522 6989
 Fax: +852 2522 1989

www.edifier.com
 © 2024 Edifier International Limited. All rights reserved.
 Printed in China

NOTICE:
 For the need of technical improvement and system upgrade, information contained herein may be subject to change from time to time without prior notice.
 Products of EDIFIER will be customized for different applications. Pictures and illustrations shown on this manual may be slightly different from actual product. If any difference is found, the actual product prevails.



- EN What's in the box?
- FR Contenu de la boîte
- ES Contenido de la caja
- DE Lieferumfang
- IT Contenuto della confezione
- PT Conteúdo da caixa
- NL Wat zit er in de doos?
- PL Zawartość pudełka
- CZ Co je v krabici?
- SK Co je v krabici?
- DK Kassen indhold
- GR Τι υπάρχει στο κουτί?
- SV Vad finns i boxen?
- BG Какво има в кутията?
- RO Ce se află în cutie?

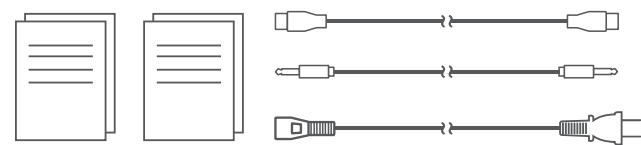
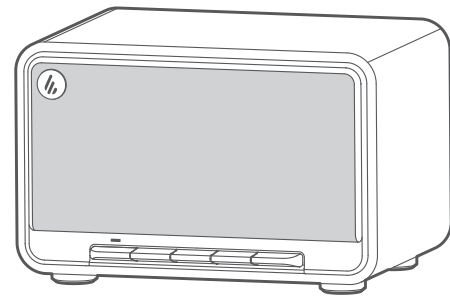

- EN Cable connection
- FR Connexion par câble
- ES Conexión de cable
- DE Kabelverbindung
- IT Collegamento cavo
- PT Conexão via cabo
- NL Kabelverbinding
- PL Złącze kablowe
- CZ Připojení kabelu
- SK Káblové pripojenie
- DK Kabeltilslutning
- GR Σύνδεση καλωδίου
- SV Kabelanslutning
- BG Кабелна връзка
- RO Conexiune cablu

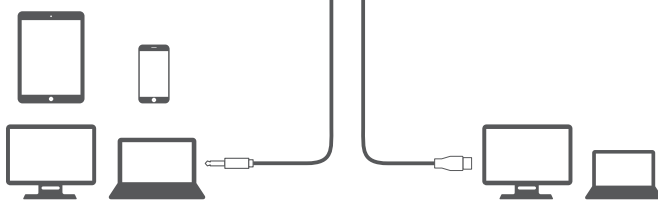
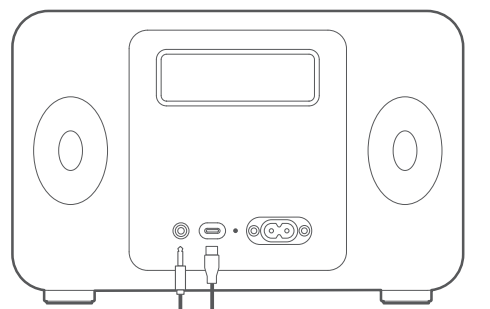

- EN Charging
- FR Chargeur
- ES Carga
- DE Laden
- IT Carica
- PT Carregamento
- NL Opladen
- PL Ładowanie
- CZ Nabíjení
- SK Nabíjanie
- DK Opladning
- GR Φόρτιση
- SV Ladda
- BG Зарядяне
- RO Încărcare

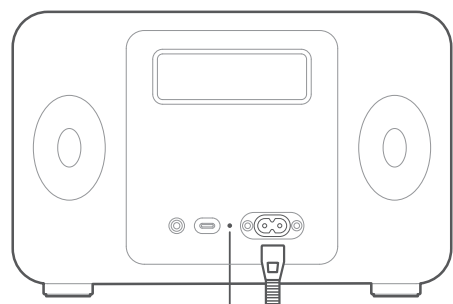

- EN Source selection
- FR Sélection de la source
- ES Selección de fuente
- DE Quellenauswahl
- IT Selezione sorgente
- PT Seleção de fonte
- NL Bron selectie
- PL Wybór źródła
- CZ Vyber zdroj
- SK Vyber zdroj
- DK Kildevalg
- GR Επιλογή πηγής
- SV Källval
- BG Избор на източник
- RO Selectare sursă

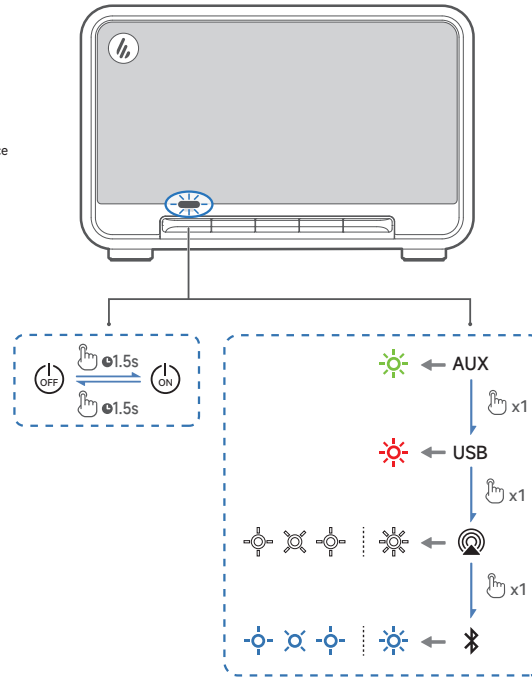

- EN Bluetooth connection
- FR Connexion Bluetooth
- ES Conexión Bluetooth
- DE Bluetooth-Kopplung
- IT Connessione Bluetooth
- PT Ligação Bluetooth
- NL Bluetoothverbinding
- PL Podłączenie Bluetooth
- CZ Připojení Bluetooth
- SK Pripojenie k Bluetooth
- DK Bluetooth-forbindelse
- GR Σύνδεση Bluetooth
- SV Bluetooth-anslutning
- BG Bluetooth връзка
- RO Conexiune Bluetooth

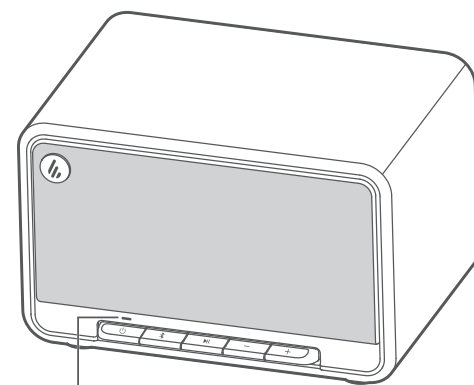

- EN Apple Airplay
- FR Apple Airplay
- ES Apple Airplay
- DE Apple Airplay
- IT Apple Airplay
- PT Apple Airplay
- NL Apple Airplay
- PL Apple Airplay
- CZ Apple Airplay
- SK Apple Airplay
- DK Apple Airplay
- GR Apple Airplay
- SV Apple Airplay
- BG Apple Airplay
- RO Apple Airplay

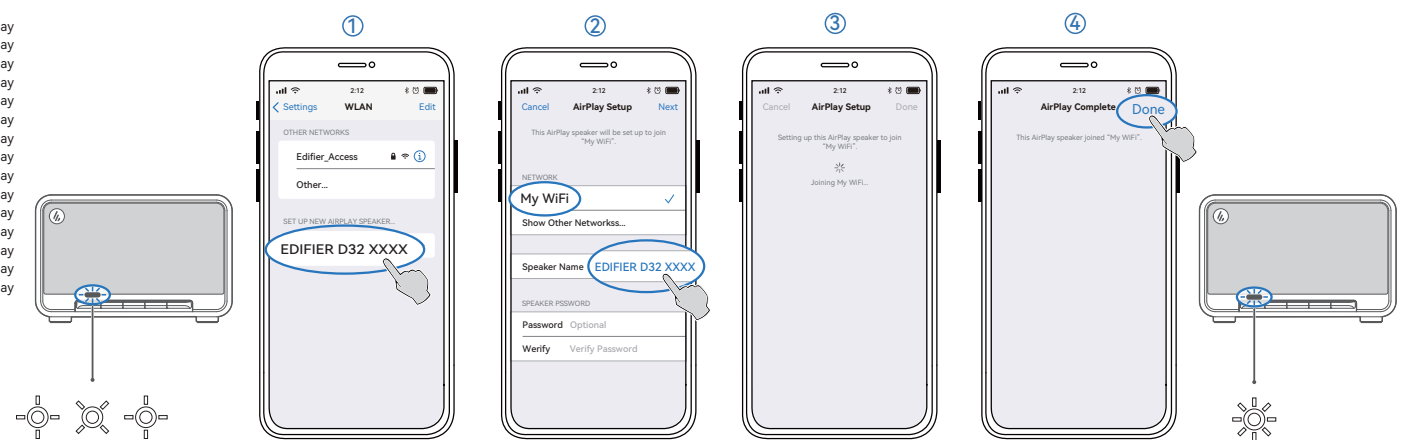

- EN USB connection
- FR Connexion USB
- ES Conexión USB
- DE USB-Anschluss
- IT Collegamento USB
- PT Conexão USB
- NL USB-aansluiting
- PL Złącze USB
- CZ Připojení USB
- SK Pripojenie cez rozhranie USB
- DK USB-tilslutning
- GR Σύνδεση USB
- SV USB-anslutning
- BG Връзка USB
- RO Conexiune USB

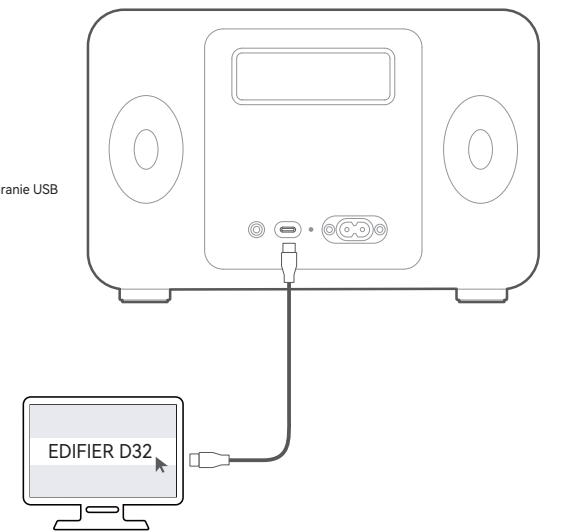

- EN Play control
- FR Contrôle de lecture
- ES Control de reproducción
- DE Abspielsteuerung
- IT Controllo riproduzione
- PT Controlo de reprodução
- NL Afspelenbediening
- PL Sterowanie odtwarzania
- CZ Ovládač přehrávání
- SK Ovládanie prehrávania
- DK Afspilningskontrol
- GR Ελεγχος αναπαραγωγής
- SV Uppspelningskontroll
- BG Управление на възпроизвеждането
- RO Control redare

