

**FCC 47 CFR PART 15 SUBPART E**  
**CERTIFICATION TEST REPORT**

*For*

cnPilot Home Wireless Access Point

MODEL No.: REG-PL-R195W

FCC ID: Z8H89FT0049

Trade Mark: Cambium Networks

REPORT NO.: ES181229009W02-3

ISSUE DATE: July 9, 2019

*Prepared for*

Cambium Networks Inc.

3800 Golf Road, Suite 360 Rolling Meadows, IL 60008 USA

*Prepared by*

EMTEK(SHENZHEN) CO., LTD.

Bldg 69, Majialong Industry Zone, Nanshan District,  
Shenzhen, Guangdong, China

TEL: 86-755-26954280

FAX: 86-755-26954282

# 1 TEST RESULT CERTIFICATION

Applicant: Cambium Networks Inc.  
3800 Golf Road, Suite 360 Rolling Meadows, IL 60008 USA

Manufacturer: Cambium Networks Ltd.  
Unit B2 Linhay Business Park Eastern Rd Ashburton, Devon TQ13 7UP United Kingdom

Factory: Flyingvoice Network Technology Co., Ltd  
Room 207~209, 2/F, Bldg B52#, Zhongchuang industrial park, Liuxian Avenue, Taoyuan street, Nanshan District, Shenzhen, China

Product Description: cnPilot Home Wireless Access Point

Model Number: REG-PL-R195W

Trade Mark: Cambium Networks

Measurement Procedure Used:

APPLICABLE STANDARDS	
STANDARD	TEST RESULT
FCC 47 CFR Part 2, Subpart J FCC 47 CFR Part 15, Subpart E	PASS

The above equipment was tested by EMTEK(SHENZHEN) CO., LTD.. The test data, data evaluation, test procedures, and equipment configurations shown in this report were made in accordance with the procedures given in ANSI C63.10 (2013) and the energy emitted by the sample EUT tested as described in this report is in compliance with the requirements of FCC Rules Part 2 and Part 15.407

The test results of this report relate only to the tested sample identified in this report.

Date of Test : June 25, 2019 to July 9 , 2019

Prepared by : *Doris Su.*  
Doris Su/Editor

Reviewer : *Yaping Shen*  
Yaping Shen/Supervisor

Approve & Authorized Signer : *Lisa Wang*  
Lisa Wang/Manager



Modified History

Rev.	Summary	Date of Rev.	Report No.
V1.0	Original Report	March 01, 2019	ES181229002W02
V1.0	Updated applicant, manufacturer; Product Name, Model Number	March 07, 2019	ES181229002W02-1
V1.0	Updated manufacturer, factory	April 08, 2019	ES181229002W02-2
V1.0	Updated 5G WIFI Power level	July 9, 2019	ES181229002W02-3

**TABLE OF CONTENTS**

**1 TEST RESULT CERTIFICATION .....2**

**2 EUT TECHNICAL DESCRIPTION .....5**

**3 SUMMARY OF TEST RESULT .....7**

**4 TEST METHODOLOGY .....8**

4.1 GENERAL DESCRIPTION OF APPLIED STANDARDS ..... 8

4.2 MEASUREMENT EQUIPMENT USED ..... 8

4.3 DESCRIPTION OF TEST MODES ..... 9

**5 FACILITIES AND ACCREDITATIONS .....12**

5.1 FACILITIES..... 12

5.2 LABORATORY ACCREDITATIONS AND LISTINGS ..... 12

**6 TEST SYSTEM UNCERTAINTY .....13**

**7 SETUP OF EQUIPMENT UNDER TEST .....14**

7.1 RADIO FREQUENCY TEST SETUP ..... 14

7.2 RADIO FREQUENCY TEST SETUP ..... 14

7.3 CONDUCTED EMISSION TEST SETUP ..... 16

7.4 BLOCK DIAGRAM CONFIGURATION OF TEST SYSTEM..... 17

7.5 SUPPORT EQUIPMENT..... 17

**8 TEST REQUIREMENTS .....18**

8.1 BANDWIDTH MEASUREMENT ..... 18

8.2 MAXIMUM CONDUCTED OUTPUT POWER..... 49

8.3 MAXIMUM PEAK POWER DENSITY ..... 55

8.4 FREQUENCY STABILITY ..... 94

8.5 UNDESIRABLE RADIATED SPURIOUS EMISSION..... 105

8.6 POWER LINE CONDUCTED EMISSIONS..... 140

8.7 ANTENNA APPLICATION ..... 143

## 2 EUT TECHNICAL DESCRIPTION

Characteristics	Description				
<b>IEEE 802.11 WLAN Mode Supported Band</b>	<input checked="" type="checkbox"/> 2.4G WIFI Band <input checked="" type="checkbox"/> 5G WIFI Band				
<b>IEEE 802.11 WLAN Mode Supported</b>	<input checked="" type="checkbox"/> 802.11b <input checked="" type="checkbox"/> 802.11g <input checked="" type="checkbox"/> 802.11a(20MHz channel bandwidth) <input checked="" type="checkbox"/> 802.11n(20MHz channel bandwidth) <input checked="" type="checkbox"/> 802.11n(40MHz channel bandwidth) <input checked="" type="checkbox"/> 802.11ac(20MHz channel bandwidth) <input checked="" type="checkbox"/> 802.11ac(40MHz channel bandwidth) <input checked="" type="checkbox"/> 802.11ac(80MHz channel bandwidth)				
<b>Data Rate</b>	802.11 b:1,2,5,5,11Mbps; 802.11 g/a:6,9,12,18,24,36,48,54Mbps; 802.11n(HT20)/ac(HT20): MCS0-MCS15; 802.11n(HT40): MCS0-MCS15; 802.11ac(HT40):MCS0-MCS15; 802.11ac(VHT80):MCS0-MCS15;				
<b>Operating Frequency Range</b>	Band	Mode	Frequency Range(MHz)	Number of channels	
	2.4G Band	802.11b/g/n(HT20)		2412-2462	11
		802.11n(HT40)		2422-2452	7
	5G Band/ UNII Band I	802.11a/n(HT20)/ac(VHT20)		5180-5240	4
		802.11n(HT40)/ac(VHT40)		5190-5230	2
		802.11 ac(VHT80)		5210	1
	5G Band/ UNII Band III	802.11a/n(HT20)/ac(VHT20)		5745-5825	5
802.11n(HT40)/ac(VHT40)		5755-5795	2		
802.11 ac(VHT80)		5775	1		
<b>Modulation</b>	DSSS with DBPSK/DQPSK/CCK for 802.11b; OFDM with BPSK/QPSK/16QAM/64QAM/256QAM for 802.11a/ac/g/n				
<b>Antenna Type</b>	External PCB Antenna				
<b>Smart system</b>	<input checked="" type="checkbox"/> SISO		<input checked="" type="checkbox"/> MIMO		
<b>Number of Antenna:</b>	Four	Two for 2.4G Band Two for 5G Band			
<b>Antenna Gain</b>	2.4G Band Antenna 0: 5dBi; Antenna 1: 5dBi 5G Band Antenna 0: 5dBi; Antenna 1: 5dB				

<b>Direction Gain</b>	2.4G Band 8.01 dBi 5G Band 8.01 dBi
<b>Power supply</b>	<input checked="" type="checkbox"/> DC 12V from Adapter
	<input checked="" type="checkbox"/> Adapter: Model: S12B23-120A100-04 Input: 100-240V~, 50-60Hz, Max 0.5A Output: DC 12V, 1A
<b>This test report is only applicable to 5G WIFI Band</b>	

**Note:** for more details, please refer to the User's manual of the EUT.

### 3 SUMMARY OF TEST RESULT

FCC Part Clause	Test Parameter	Verdict	Remark
15.407 (a) 15.407 (e)	99% , 6dB and 26dB Bandwidth	PASS	
15.407 (a)	Maximum Conducted Output Power	PASS	
15.407 (a)	Peak Power Spectral Density	PASS	
15.407 (b)	Radiated Spurious Emission	PASS	
15.407(g)	Frequency Stability	PASS	
15.407 (b)(6) 15.207	Power Line Conducted Emission	PASS	
15.407(a) 15.203	Antenna Application	PASS	
NOTE1: N/A (Not Applicable) NOTE2: According to FCC OET KDB 789033 D02 General UNII Test Procedures New Rules v02r01, In addition, the radiated test is also performed to ensure the emissions emanating from the device cabinet also comply with the applicable limits.			

RELATED SUBMITTAL(S) / GRANT(S):

This submittal(s) (test report) is intended for FCC ID: Z8H89FT0049 filing to comply with Section 15.407 of the FCC Part 15, Subpart E Rules.

## 4 TEST METHODOLOGY

### 4.1 GENERAL DESCRIPTION OF APPLIED STANDARDS

According to its specifications, the EUT must comply with the requirements of the following standards:

FCC 47 CFR Part 2, Subpart J

FCC 47 CFR Part 15, Subpart E

KDB 789033 D02 General UNII Test Procedures New Rules v02r01

FCC KDB 662911 D01 Multiple Transmitter Output v02r01

FCC KDB 662911 D02 MIMO With Cross Polarized Antenna V01

### 4.2 MEASUREMENT EQUIPMENT USED

#### 4.2.1 Conducted Emission Test Equipment

EQUIPMENT TYPE	MFR	MODEL NUMBER	SERIAL NUMBER	LASTCAL.	DUE CAL.
Test Receiver	Rohde & Schwarz	ESCI	26115-010-0027	May 18, 2019	May 17, 2020
L.I.S.N.	Rohde & Schwarz	ENV216	101161	May 18, 2019	May 17, 2020
50Ω Coaxial Switch	Anritsu	MP59B	6100175589	May 19, 2019	May 18, 2020
Voltage Probe	Rohde & Schwarz	ESH2-Z3	100122	May 19, 2019	May 18, 2020
Pulse Limiter	Rohde & Schwarz	ESH3-Z2	100006	May 18, 2019	May 17, 2020
I.S.N	Teseq GmbH	ISN T800	30327	May 19, 2019	May 18, 2020

#### 4.2.2 Radiated Emission Test Equipment

EQUIPMENT TYPE	MFR	MODEL NUMBER	SERIAL NUMBER	LAST CAL.	DUE CAL.
EMI Test Receiver	Rohde & Schwarz	ESU	1302.6005.26	May 19, 2019	May 18, 2020
Pre-Amplifier	HP	8447F	2944A07999	May 18, 2019	May 17, 2020
Bilog Antenna	Schwarzbeck	VULB9163	142	May 18, 2019	May 17, 2020
Loop Antenna	ARA	PLA-1030/B	1029	May 18, 2019	May 17, 2020
Horn Antenna	Schwarzbeck	BBHA 9170	BBHA9170399	May 19, 2019	May 18, 2020
Horn Antenna	Schwarzbeck	BBHA 9120	D143	May 18, 2019	May 17, 2020
Cable	Schwarzbeck	AK9513	ACRX1	May 19, 2019	May 18, 2020
Cable	Rosenberger	N/A	FP2RX2	May 19, 2019	May 18, 2020
Cable	Schwarzbeck	AK9513	CRPX1	May 19, 2019	May 18, 2020
Cable	Schwarzbeck	AK9513	CRRX2	May 19, 2019	May 18, 2020

#### 4.2.3 Radio Frequency Test Equipment

EQUIPMENT TYPE	MFR	MODEL NUMBER	SERIAL NUMBER	LASTCAL.	DUE CAL.
Spectrum Analyzer	Agilent	E4407B	88156318	May 19, 2019	May 18, 2020
Signal Analyzer	Agilent	N9010A	My53470879	May 19, 2019	May 18, 2020
Power meter	Anritsu	ML2495A	0824006	May 19, 2019	May 18, 2020
Power sensor	Anritsu	MA2411B	0738172	May 19, 2019	May 18, 2020
Temperature & Humidity test chamber	ESPEC	EL-02KA	12107166	May 19, 2019	May 18, 2020

**Remark:** Each piece of equipment is scheduled for calibration once a year.



### 4.3 DESCRIPTION OF TEST MODES

The EUT has been tested under its typical operating condition.

The EUT configuration for testing is installed on RF field strength measurement to meet the Commissions requirement and operating in a manner which intends to maximize its emission characteristics in a continuous normal application.

The Transmitter was operated in the normal operating mode. The TX frequency was fixed which was for the purpose of the measurements.

Test of channel included the lowest and middle and highest frequency to perform the test, then record on this report.

Those data rates (802.11a: 6 Mbps; 802.11n (HT20): MCS0; 802.11n (HT20): MCS15; 802.11n (HT40): MCS0; 802.11n (HT40): MCS15; 802.11ac (HT20): MCS0; 802.11ac (HT20): MCS15; 802.11ac (HT40): MCS0; 802.11ac (HT40): MCS15; 802.11ac (HT80): MCS0; 802.11ac (HT80): MCS15;) were used for all test.

Test software: MT7612E\_AP\_QA\_Tool\_V1.0.3.4

Power Setting:

UNII Band I and Band III

802a.11a/n(HT20)/n(HT40)/ac(VHT20)/ac(VHT40)/ac(VHT80): 15

Pre-defined engineering program for regulatory testing used to control the EUT for staying in continuous transmitting and receiving mode is programmed.

Wifi 5G with UNII Band I

Frequency and Channel list for 802.11a/n(HT20)/ac(VHT20):

Channel	Frequency (MHz)	Channel	Frequency (MHz)	Channel	Frequency (MHz)
36	5180	44	5220		
40	5200	48	5240		

Frequency and Channel list for 802.11n(HT40)/ac(VHT40):

Channel	Frequency (MHz)	Channel	Frequency (MHz)	Channel	Frequency (MHz)
38	5190				
46	5230				

Frequency and Channel list for 802.11ac(VHT80):

Channel	Frequency (MHz)	Channel	Frequency (MHz)	Channel	Frequency (MHz)
42	5210				

**Test** Frequency and Channel for 802.11a/n(HT20)/ac(VHT20):

Lowest Frequency		Middle Frequency		Highest Frequency	
Channel	Frequency (MHz)	Channel	Frequency (MHz)	Channel	Frequency (MHz)
36	5180	40	5200	48	5240

**Test** Frequency and channel for 802.11n (VHT40)/ac(VHT40):

Lowest Frequency		Middle Frequency		Highest Frequency	
Channel	Frequency (MHz)	Channel	Frequency (MHz)	Channel	Frequency (MHz)
38	5190	N/A	N/A	46	5230

**Test** Frequency and channel for 802.11ac (HT80):

Lowest Frequency		Middle Frequency		Highest Frequency	
Channel	Frequency (MHz)	Channel	Frequency (MHz)	Channel	Frequency (MHz)
42	5210	N/A	N/A	N/A	N/A

Wifi 5G with UNII Band III

Frequency and Channel list for 802.11a/n(HT20)/ac(VHT20):

Channel	Frequency (MHz)	Channel	Frequency (MHz)	Channel	Frequency (MHz)
149	5745	157	5785	165	5825
153	5765	161	5805		

Frequency and Channel list for 802.11n(HT40)/ac(VHT40):

Channel	Frequency (MHz)	Channel	Frequency (MHz)	Channel	Frequency (MHz)
151	5755				
159	5795				

Frequency and Channel list for 802.11ac(VHT80):

Channel	Frequency (MHz)	Channel	Frequency (MHz)	Channel	Frequency (MHz)
155	5775				

**Test** Frequency and Channel for 802.11a/n(HT20)/ac(VHT20):

Lowest Frequency		Middle Frequency		Highest Frequency	
Channel	Frequency (MHz)	Channel	Frequency (MHz)	Channel	Frequency (MHz)
149	5745	157	5785	165	5825

**Test** Frequency and channel for 802.11n(HT40)/ac(VHT40):

Lowest Frequency		Middle Frequency		Highest Frequency	
Channel	Frequency (MHz)	Channel	Frequency (MHz)	Channel	Frequency (MHz)
151	5755	N/A	N/A	159	5795

**Test** Frequency and channel for 802.11ac(VHT80):

Lowest Frequency		Middle Frequency		Highest Frequency	
Channel	Frequency (MHz)	Channel	Frequency (MHz)	Channel	Frequency (MHz)
155	5775				

## 5 FACILITIES AND ACCREDITATIONS

### 5.1 FACILITIES

All measurement facilities used to collect the measurement data are located at

Bldg 69, Majialong Industry Zone District, Nanshan District, Shenzhen, China

The sites are constructed in conformance with the requirements of ANSI C63.7, ANSI C63.10 and CISPR Publication 22.

### 5.2 LABORATORY ACCREDITATIONS AND LISTINGS

Site Description

EMC Lab.

: Accredited by CNAS,2016.10.24

The certificate is valid until 2022.10.28

The Laboratory has been assessed and proved to be in compliance with CNAS-CL01:2006 (identical to ISO/IEC 17025:2005)

The Certificate Registration Number is L2291.

Accredited by TUV Rheinland Shenzhen 2016.5.19

The Laboratory has been assessed according to the requirements ISO/IEC 17025.

Accredited by FCC, August 06, 2018

The certificate is valid until August 07, 2020

Designation Number: CN1204

Test Firm Registration Number: 882943

Accredited by Industry Canada, November 09, 2018

The Conformity Assessment Body Identifier is CN0008.

Name of Firm

: EMTEK(SHENZHEN) CO., LTD.

Site Location

: Bldg 69, Majialong Industry Zone,  
Nanshan District, Shenzhen, Guangdong, China

## 6 TEST SYSTEM UNCERTAINTY

The following measurement uncertainty levels have been estimated for tests performed on the apparatus:

Parameter	Uncertainty
Radio Frequency	$\pm 1 \times 10^{-5}$
Maximum Peak Output Power Test	$\pm 1.0\text{dB}$
Conducted Emissions Test	$\pm 2.0\text{dB}$
Radiated Emission Test	$\pm 2.0\text{dB}$
Power Density	$\pm 2.0\text{dB}$
Occupied Bandwidth Test	$\pm 1.0\text{dB}$
Band Edge Test	$\pm 3\text{dB}$
All emission, radiated	$\pm 3\text{dB}$
Antenna Port Emission	$\pm 3\text{dB}$
Temperature	$\pm 0.5^{\circ}\text{C}$
Humidity	$\pm 3\%$

Measurement Uncertainty for a level of Confidence of 95%

## 7 SETUP OF EQUIPMENT UNDER TEST

### 7.1 RADIO FREQUENCY TEST SETUP

The WLAN component's antenna ports(s) of the EUT are connected to the measurement instrument per an appropriate attenuator. The EUT is controlled by PC/software to emit the specified signals for the purpose of measurements.

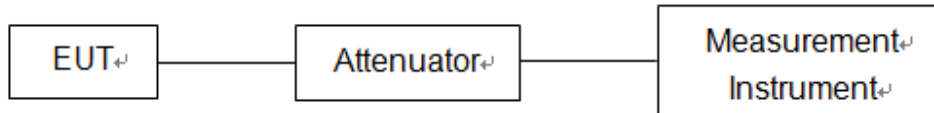

### 7.2 RADIO FREQUENCY TEST SETUP

The test site semi-anechoic chamber has met the requirement of NSA tolerance 4 dB according to the standards: ANSI C63.10. The test distance is 3m. The setup is according to the requirements in Section 13.1.4.1 of ANSI C63.10-2013 and CAN/CSA-CEI/IEC CISPR 22.

Below 30MHz:

The EUT is placed on a turntable 0.8 meters above the ground in the chamber, 3 meter away from the antenna (loop antenna). The Antenna should be positioned with its plane vertical at the specified distance from the EUT and rotated about its vertical axis for maximum response at each azimuth about the EUT. The center of the loop shall be 1 m above the ground. For certain applications, the loop antenna plane may also need to be positioned horizontally at the specified distance from the EUT.

Above 30MHz:

The EUT is placed on a turntable 0.8 meters above the ground in the chamber, 3 meter away from the antenna. The maximal emission value is acquired by adjusting the antenna height, polarisation and turntable azimuth. Normally, the height range of antenna is 1 m to 4 m, the azimuth range of turntable is 0° to 360°, and the receive antenna has two polarizations Vertical (V) and Horizontal (H).

Above 1GHz:

(Note: the FCC's permission to use 1.5m as an alternative per TCBC Conf call of Dec. 2, 2014.)

The EUT is placed on a turntable 1.5 meters above the ground in the chamber, 3 meter away from the antenna. The maximal emission value is acquired by adjusting the antenna height, polarisation and turntable azimuth. Normally, the height range of antenna is 1 m to 4 m, the azimuth range of turntable is 0° to 360°, and the receive antenna has two polarizations Vertical (V) and Horizontal (H).

(a) Radiated Emission Test Set-Up, Frequency Below 30MHz

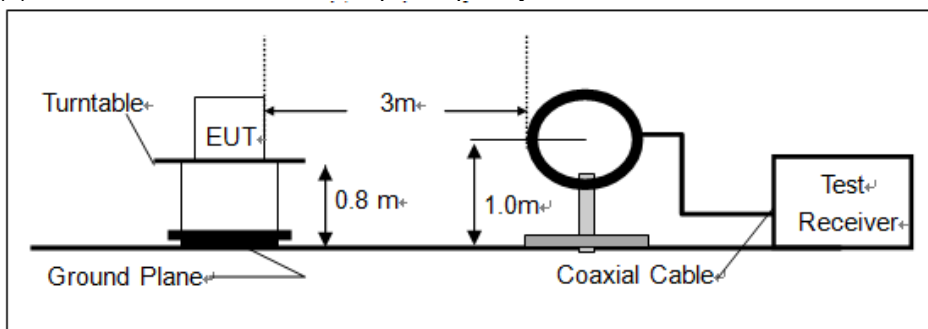

(b) Radiated Emission Test Set-Up, Frequency Below 1000MHz

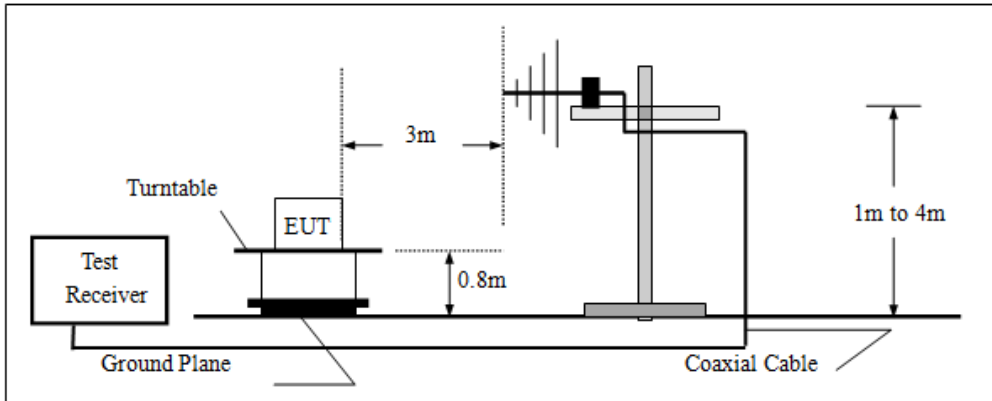

(c) Radiated Emission Test Set-Up, Frequency above 1000MHz

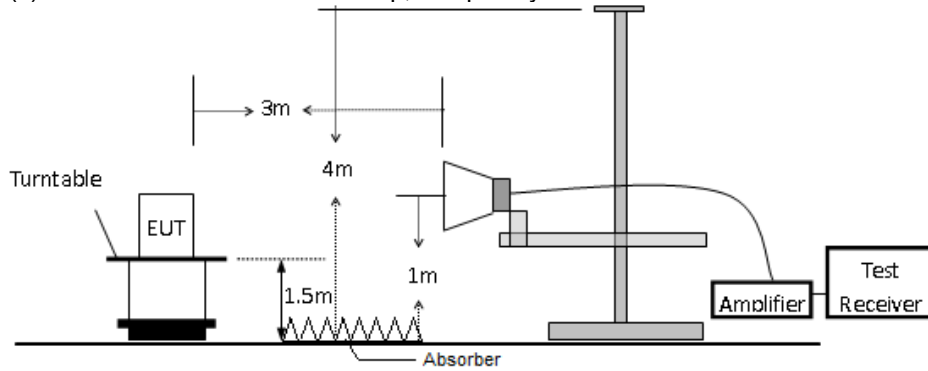

### 7.3 CONDUCTED EMISSION TEST SETUP

The mains cable of the EUT (maybe per AC/DC Adapter) must be connected to LISN. The LISN shall be placed 0.8 m from the boundary of EUT and bonded to a ground reference plane for LISN mounted on top of the ground reference plane. This distance is between the closest points of the LISN and the EUT. All other units of the EUT and associated equipment shall be at least 0.8m from the LISN.

Ground connections, where required for safety purposes, shall be connected to the reference ground point of the LISN and, where not otherwise provided or specified by the manufacturer, shall be of same length as the mains cable and run parallel to the mains connection at a separation distance of not more than 0.1 m.

According to the requirements in Section 13.1.4.1 of ANSI C63.10-2013 Conducted emissions from the EUT measured in the frequency range between 0.15 MHz and 30 MHz using CISPR Quasi-Peak and average detector mode.

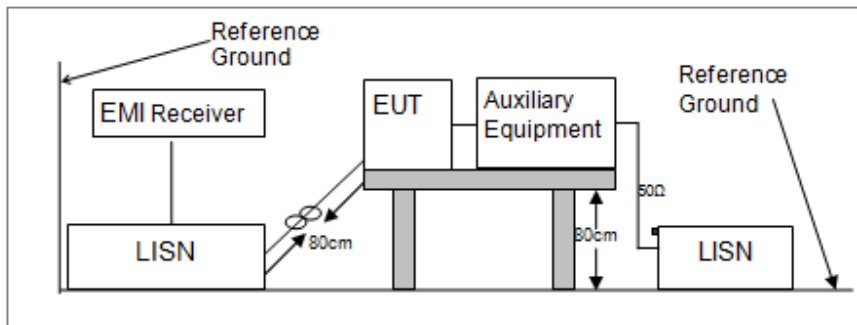



#### 7.4 BLOCK DIAGRAM CONFIGURATION OF TEST SYSTEM

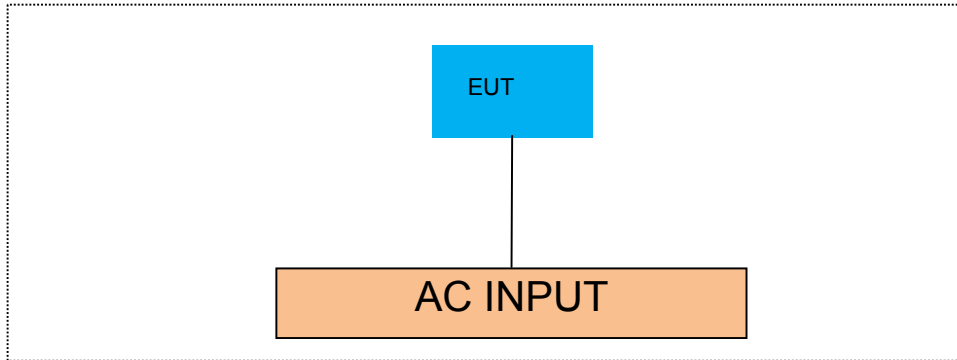

#### 7.5 SUPPORT EQUIPMENT

Item	Equipment	Mfr/Brand	Model/Type No.	FCC ID	Series No.	Note
N/A	N/A	N/A	N/A	N/A	N/A	N/A

**Notes:**

1. All the equipment/cables were placed in the worst-case configuration to maximize the emission during the test.
2. Grounding was established in accordance with the manufacturer's requirements and conditions for the intended use.

## 8 TEST REQUIREMENTS

### 8.1 BANDWIDTH MEASUREMENT

#### 8.1.1 Applicable Standard

According to FCC Part 15.407(a)(1) for UNII Band I  
According to FCC Part 15.407(a)(2) for UNII Band II-A and UNII Band II-C  
According to FCC Part 15.407(a)(3) for UNII Band III  
According to FCC Part 15.407(e) for UNII Band III  
According to 789033 D02 Section II(C)  
According to 789033 D02 Section II(D)

#### 8.1.2 Conformance Limit

No limit requirement.

The minimum 6 dB emission bandwidth of at least 500 KHz for the UNII Band III.

#### 8.1.3 Test Configuration

Test according to clause 6.1 radio frequency test setup

#### 8.1.4 Test Procedure

Connect the antenna port(s) to the spectrum analyzer input. Using the spectrum analyzer Channel Bandwidth mode, configure the spectrum analyzer as shown below

■ The following procedure shall be used for measuring (26 dB) power bandwidth:

Center Frequency: test Frequency

Set RBW = approximately 1% of the emission bandwidth.

Set the VBW > RBW.

Detector = Peak.

Trace mode = max hold.

X dB Bandwidth: 26 dB

Measure the maximum width of the emission that is 26 dB down from the maximum of the emission.

Compare this with the RBW setting of the analyzer. Readjust RBW and repeat measurement as needed until the RBW/EBW ratio is approximately 1%.

■ Minimum Emission Bandwidth for the UNII Band III

Center Frequency: test Frequency

Set RBW = 100 kHz

Set VBW  $\geq 3 \cdot$  RBW

Detector = Peak

Trace mode = max hold

Sweep = auto couple

X dB Bandwidth: 6 dB

Note: The automatic bandwidth measurement capability of a spectrum analyzer or EMI receiver may be employed if it implements the functionality described above.

■ The following procedure shall be used for measuring (99 %) power bandwidth:

Set center frequency to the nominal EUT channel center frequency.

Set span = 1.5 times to 5.0 times the OBW.

Set RBW = 1 % to 5 % of the OBW

Set VBW  $\geq 3 \cdot$  RBW

Video averaging is not permitted. Where practical, a sample detection and single sweep mode shall be used. Otherwise, peak detection and max hold mode (until the trace stabilizes) shall be used.

Use the 99 % power bandwidth function of the instrument (if available).

If the instrument does not have a 99 % power bandwidth function, the trace data points are recovered and directly summed in power units. The recovered amplitude data points, beginning at the lowest frequency, are placed in a running sum until 0.5 % of the total is reached; that frequency is recorded as the lower frequency. The process is repeated until 99.5 % of the total is reached; that frequency is recorded as the upper frequency. The 99% occupied bandwidth is the difference between these two frequencies.

8.1.5 Test Results

		<input checked="" type="checkbox"/> 802.11a mode	
Temperature :	28 °C	Test By:	King Kong
Humidity :	65 %		

Band	Channel Number	Channel Freq. (MHz)	26dB EBW	99% OBW	Limit (MHz)	Verdict
UNII Band I	CH36	5180	21.52	17.06	N/A	N/A
	CH40	5200	25.78	17.147	N/A	N/A
	CH48	5240	23.99	17.073	N/A	N/A
UNII Band III	CH149	5745	29.34	17.174	N/A	N/A
	CH157	5785	31.42	17.280	N/A	N/A
	CH165	5825	25.88	17.157	N/A	N/A
Note: N/A (Not Applicable)						

		<input checked="" type="checkbox"/> 802.11n(VHT20) mode	
Temperature :	28 °C	Test By:	King Kong
Humidity :	65 %		

Band	Channel Number	Channel Freq. (MHz)	26dB EBW	99% OBW	Limit (MHz)	Verdict
UNII Band I	CH36	5180	20.63	17.704	N/A	N/A
	CH40	5200	20.71	17.716	N/A	N/A
	CH48	5240	20.58	17.699	N/A	N/A
UNII Band III	CH149	5745	31.66	18.080	N/A	N/A
	CH157	5785	31.65	18.038	N/A	N/A
	CH165	5825	31.01	17.891	N/A	N/A
Note: N/A (Not Applicable)						

		<input checked="" type="checkbox"/> 802.11ac(VHT20) mode	
Temperature :	28 °C	Test By:	King Kong
Humidity :	65 %		

Band	Channel Number	Channel Freq. (MHz)	26dB EBW	99% OBW	Limit (MHz)	Verdict
UNII Band I	CH36	5180	20.47	17.711	N/A	N/A
	CH40	5200	20.63	17.728	N/A	N/A
	CH48	5240	20.63	17.717	N/A	N/A
UNII Band III	CH149	5745	22.76	17.783	N/A	N/A
	CH157	5785	22.60	17.739	N/A	N/A
	CH165	5825	22.67	17.756	N/A	N/A
Note: N/A (Not Applicable)						

802.11n(VHT40) mode

Temperature : 28 °C    Test By: King Kong  
Humidity : 65 %

Band	Channel Number	Channel Freq. (MHz)	26dB EBW	99% OBW	Limit (MHz)	Verdict
UNII Band I	CH38	5190	40.97	36.062	N/A	N/A
	CH46	5230	39.97	36.003	N/A	N/A
UNII Band III	CH151	5755	50.76	36.060	N/A	N/A
	CH159	5795	67.89	36.385	N/A	N/A

Note:  
N/A (Not Applicable)

802.11ac(VHT40) mode

Temperature : 28 °C    Test By: King Kong  
Humidity : 65 %

Band	Channel Number	Channel Freq. (MHz)	26dB EBW	99% OBW	Limit (MHz)	Verdict
UNII Band I	CH38	5190	40.31	36.041	N/A	N/A
	CH46	5230	40.17	36.018	N/A	N/A
UNII Band III	CH151	5755	54.32	37.937	N/A	N/A
	CH159	5795	64.82	36.352	N/A	N/A

Note:  
N/A (Not Applicable)

802.11ac(VHT80) mode

Temperature : 28 °C    Test By: King Kong  
Humidity : 65 %

Band	Channel Number	Channel Freq. (MHz)	26dB EBW	99% OBW	Limit (MHz)	Verdict
UNII Band I	CH42	5210	91.76	75.219	N/A	N/A
UNII Band III	CH155	5775	116.5	75.448	N/A	N/A

Note:  
N/A (Not Applicable)

Temperature : 28°C       UNII Band III  
 Humidity : 65 %      Test By: King Kong

Operation Mode	Channel Number	Channel Freq. (MHz)	6dB EBW	Limit (MHz)	Verdict
802.11a	CH149	5745	16.56	500	PASS
	CH157	5785	16.50	500	PASS
	CH165	5825	17.00	500	PASS
802.11n (VHT20)	CH149	5745	17.68	500	PASS
	CH157	5785	16.69	500	PASS
	CH165	5825	17.67	500	PASS
802.11ac (VHT20)	CH149	5745	17.66	500	PASS
	CH157	5785	17.69	500	PASS
	CH165	5825	17.67	500	PASS
802.11n (VHT40)	CH151	5755	36.43	500	PASS
	CH159	5795	36.44	500	PASS
802.11ac (VHT40)	CH151	5755	36.45	500	PASS
	CH159	5795	36.42	500	PASS
802.11ac (VHT80)	CH155	5775	75.48	500	PASS
Note: N/A (Not Applicable)					

Emission Bandwidth&99% Occupied Bandwidth	UNII Band I
Test Model 802.11a	Frequency(MHz) 5180

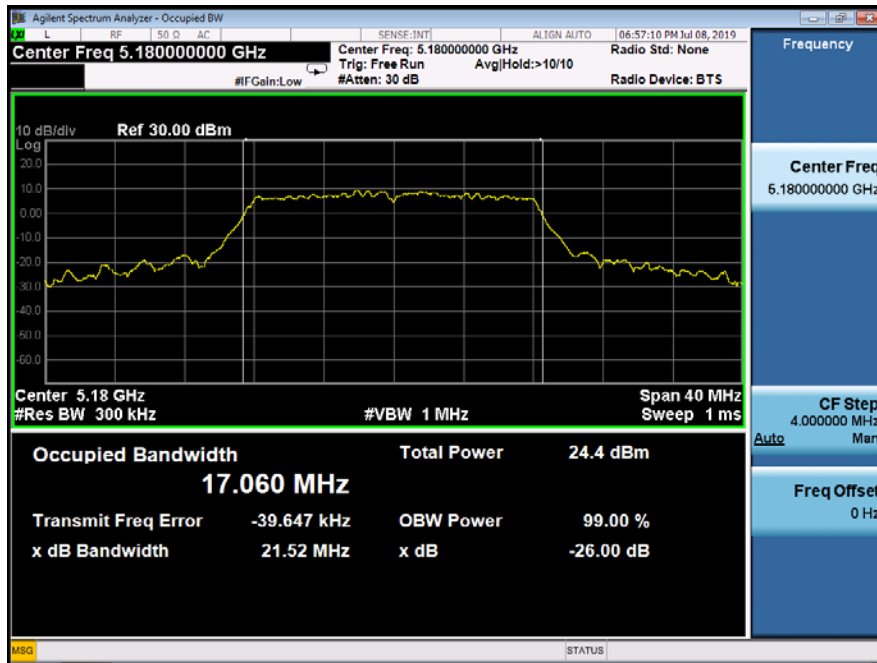

Emission Bandwidth&99% Occupied Bandwidth	UNII Band I
Test Model 802.11a	Frequency(MHz) 5200

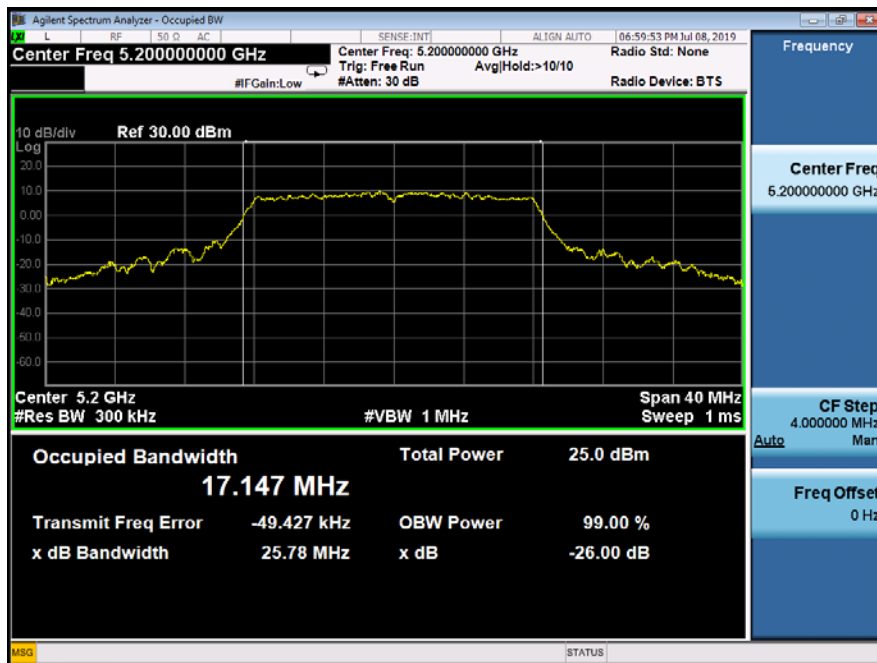

Emission Bandwidth&99% Occupied Bandwidth	UNII Band I
Test Model 802.11a	Frequency(MHz) 5240

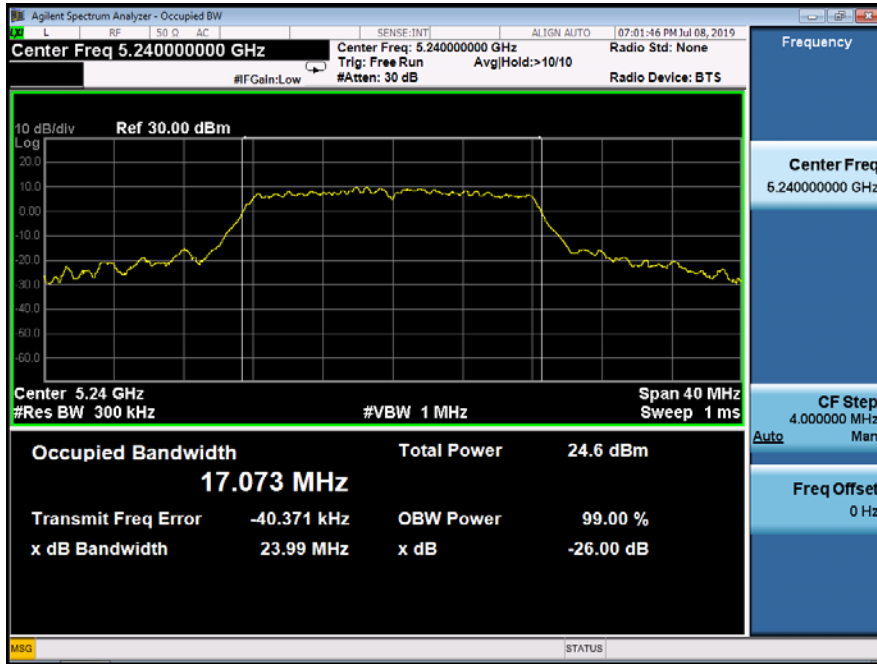

Emission Bandwidth&99% Occupied Bandwidth	UNII Band III
Test Model 802.11a	Frequency(MHz) 5745

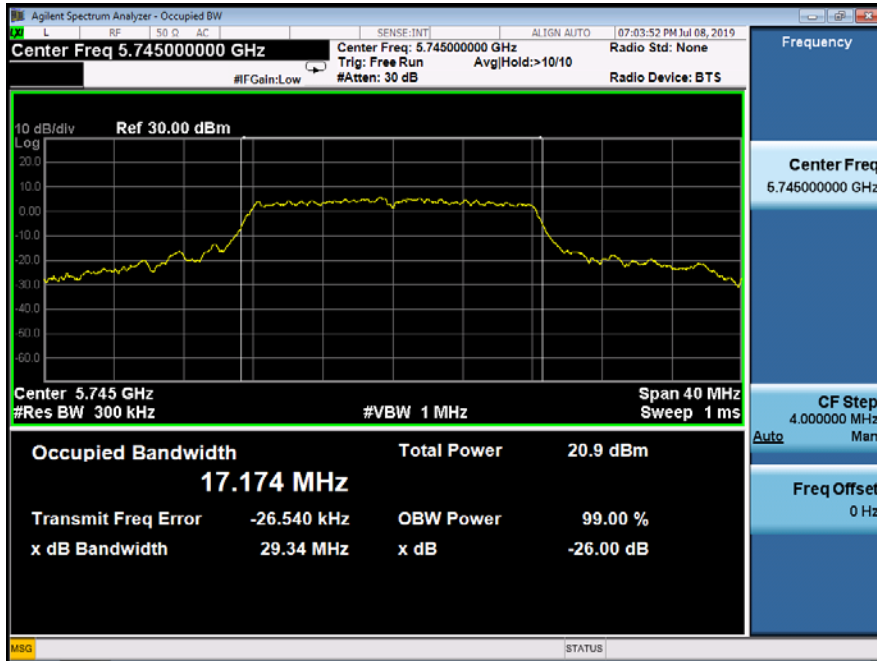

Emission Bandwidth&99% Occupied Bandwidth	UNII Band III
Test Model 802.11a	Frequency(MHz) 5785

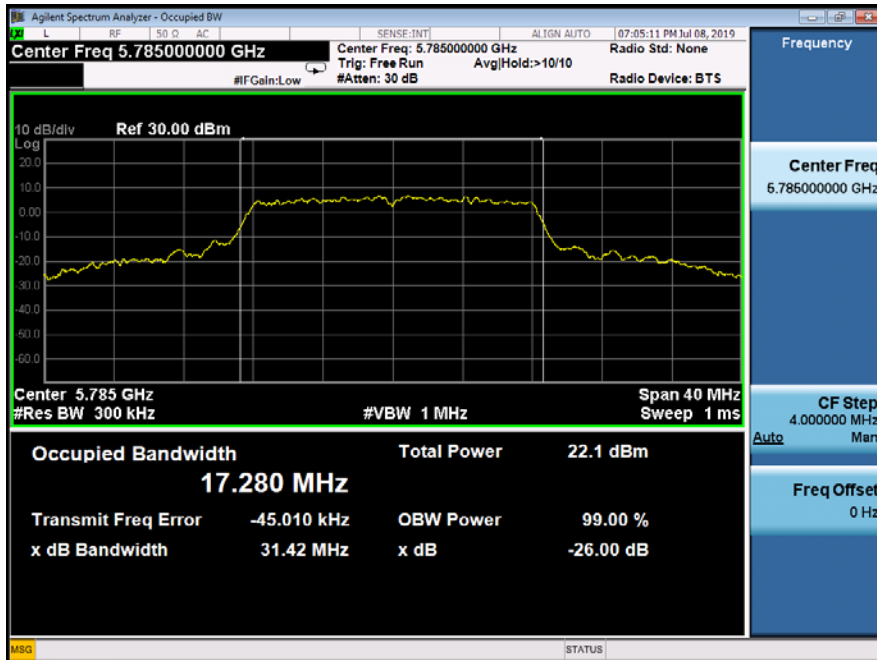



Emission Bandwidth&99% Occupied Bandwidth	UNII Band III
Test Model 802.11a	Frequency(MHz) 5825

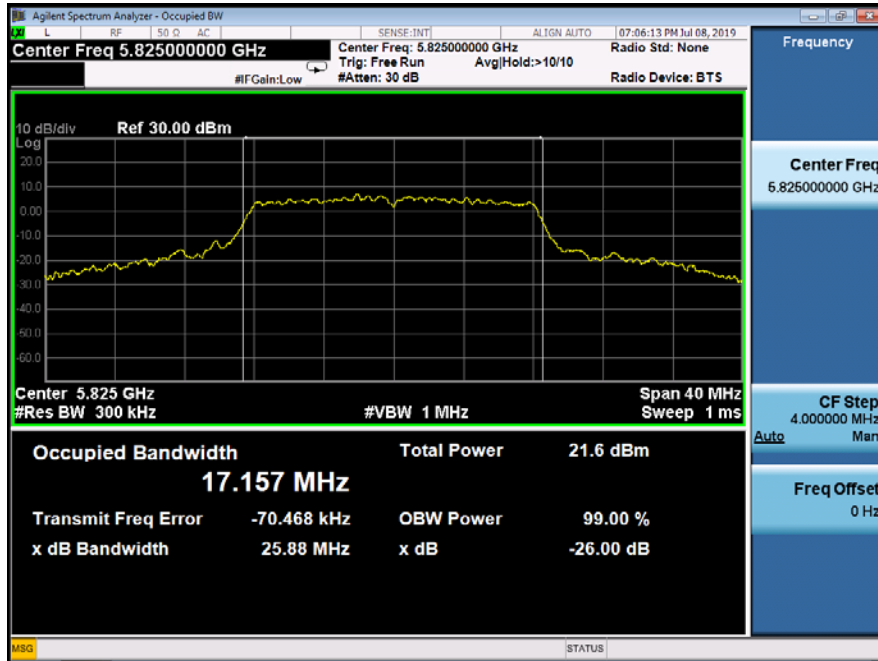

Emission Bandwidth&99% Occupied Bandwidth	UNII Band I
Test Model 802.11n(HT20) mode	Frequency(MHz) 5180

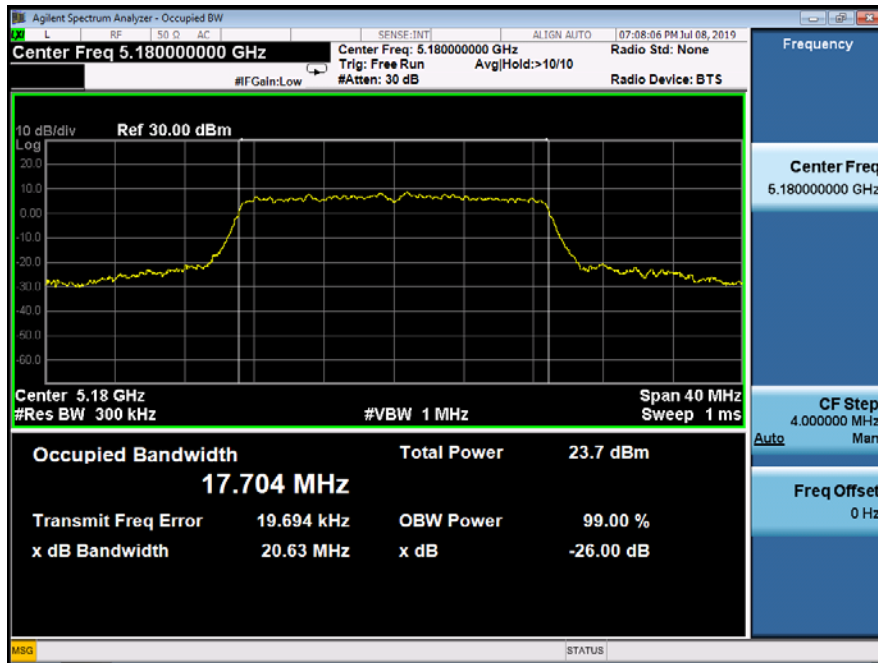

Emission Bandwidth&99% Occupied Bandwidth	UNII Band I
Test Model 802.11n(HT20) mode	Frequency(MHz) 5200

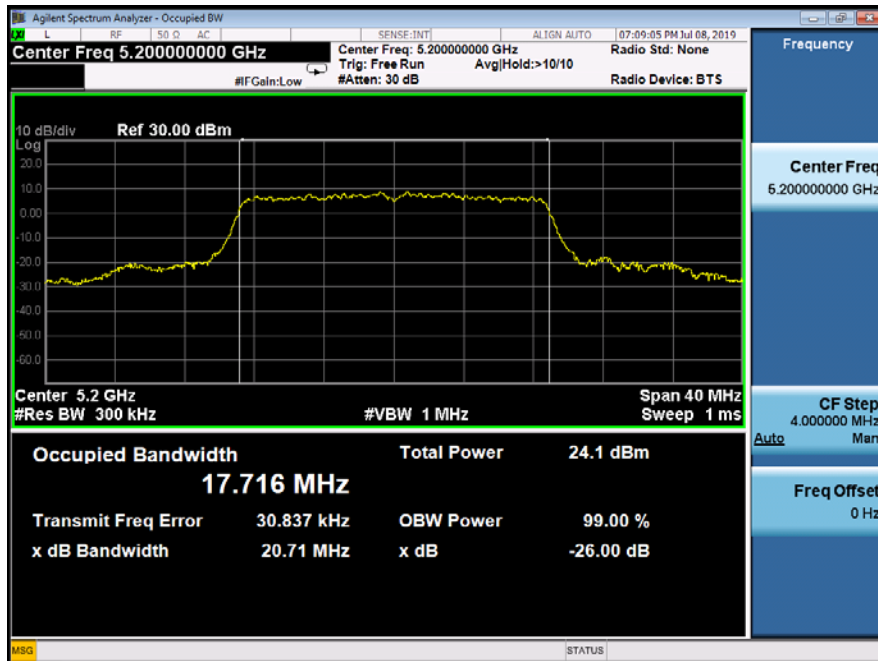

Emission Bandwidth&99% Occupied Bandwidth	UNII Band I
Test Model 802.11n(HT20) mode	Frequency(MHz) 5240

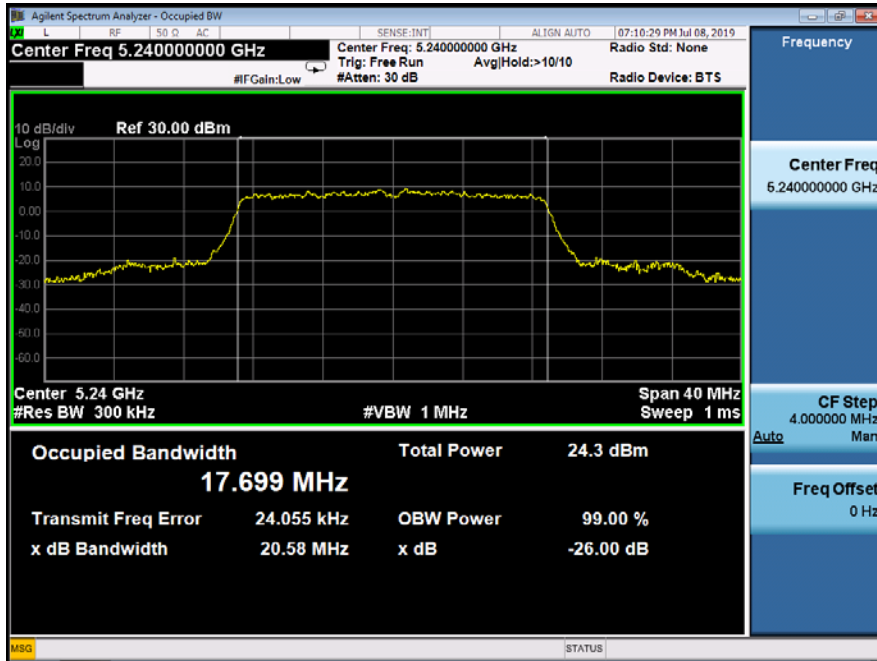

Emission Bandwidth&99% Occupied Bandwidth	UNII Band III
Test Model 802.11n(HT20) mode	Frequency(MHz) 5745

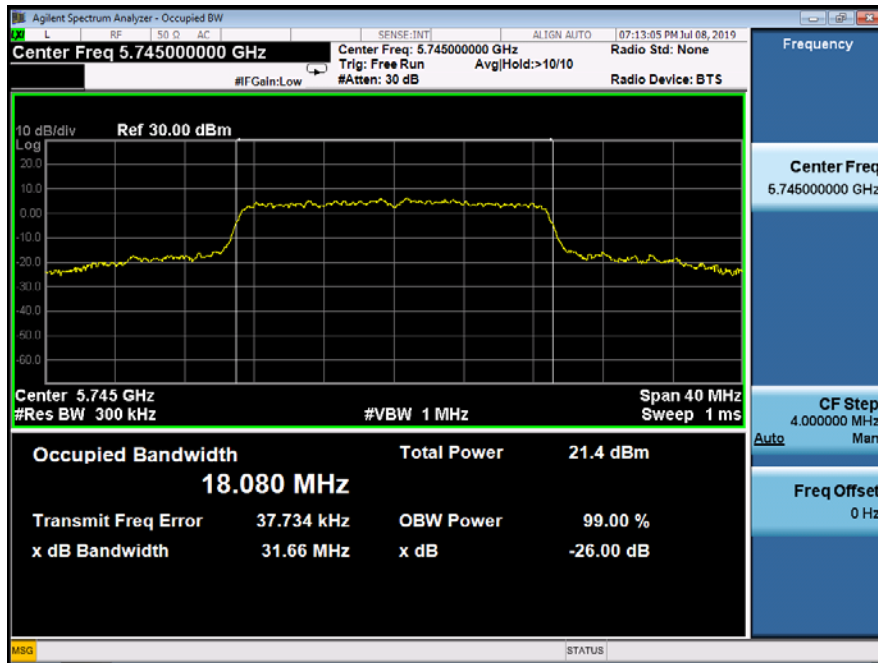

Emission Bandwidth&99% Occupied Bandwidth	UNII Band III
Test Model 802.11n(HT20) mode	Frequency(MHz) 5785

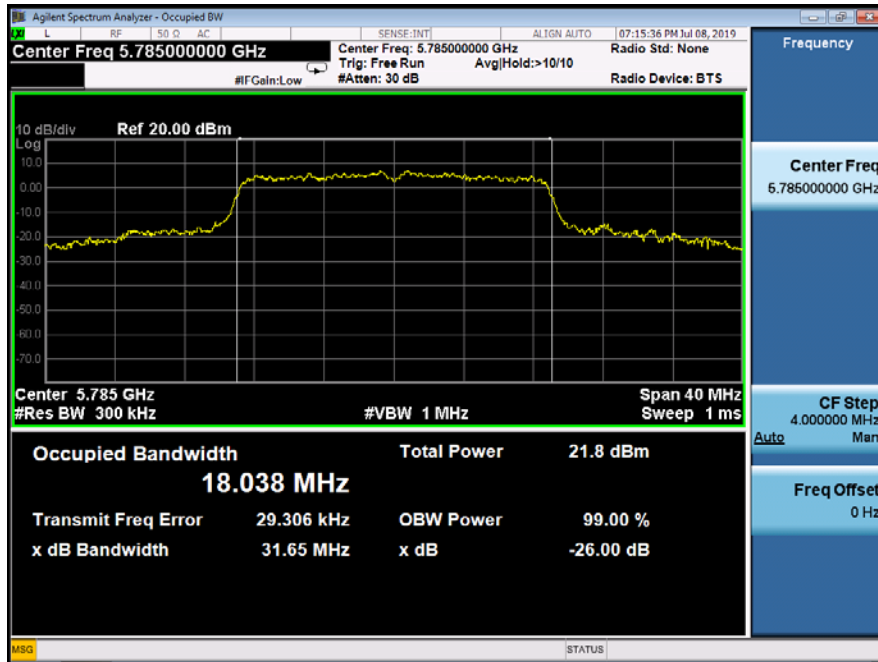

Emission Bandwidth&99% Occupied Bandwidth	UNII Band III
Test Model 802.11n(HT20) mode	Frequency(MHz) 5825

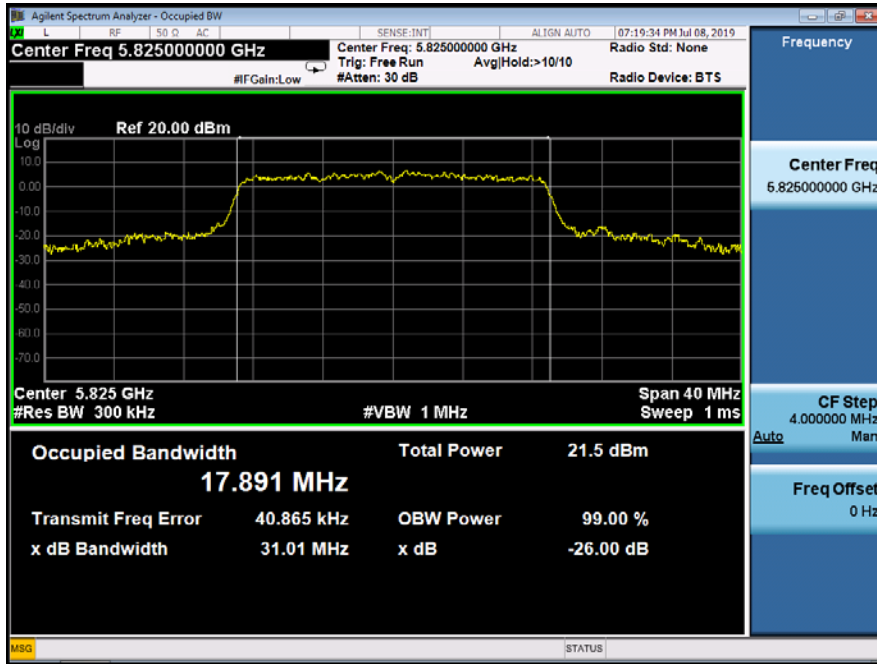

Emission Bandwidth&99% Occupied Bandwidth	UNII Band I
Test Model 802.11ac(VHT20) mode	Frequency(MHz) 5180

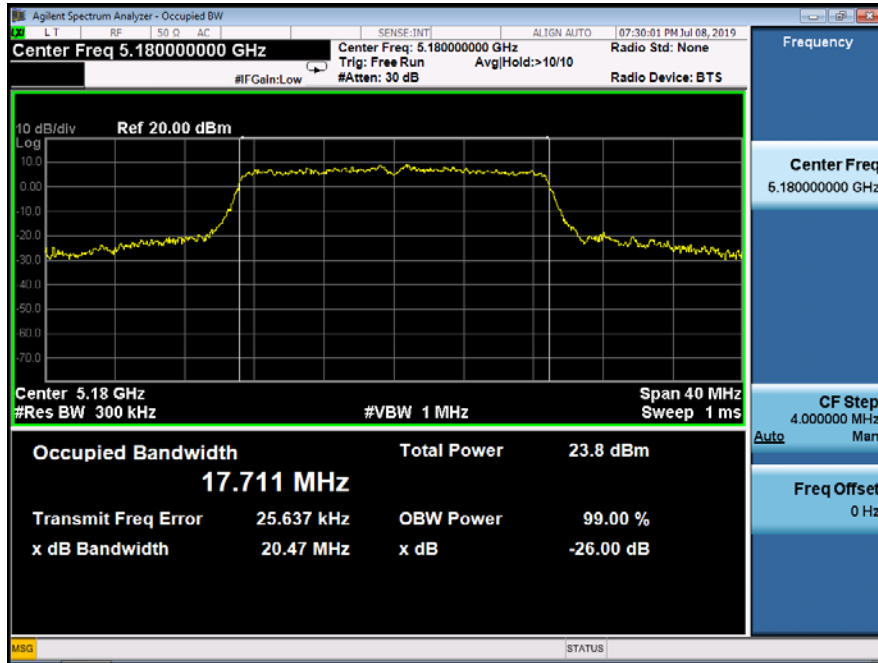

Emission Bandwidth&99% Occupied Bandwidth	UNII Band I
Test Model 802.11ac(VHT20) mode	Frequency(MHz) 5200

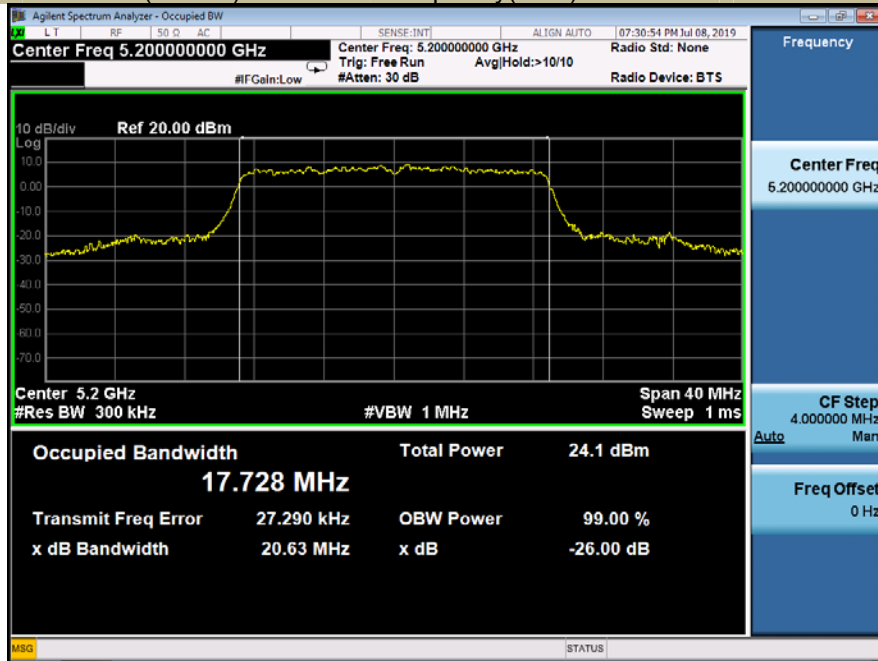

Emission Bandwidth&99% Occupied Bandwidth	UNII Band I
Test Model 802.11ac(VHT20) mode	Frequency(MHz) 5240

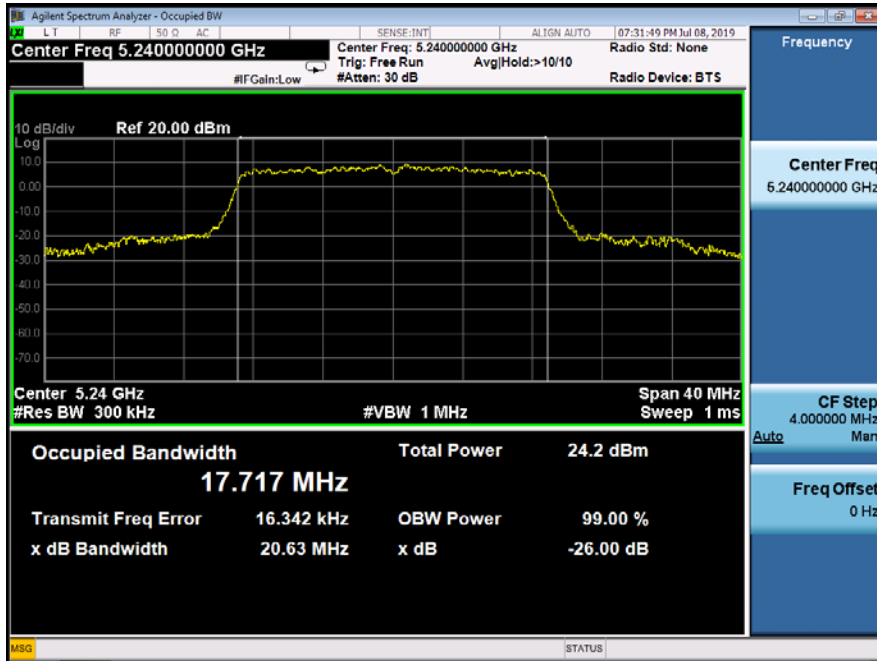

Emission Bandwidth&99% Occupied Bandwidth	UNII Band III
Test Model 802.11ac(VHT20) mode	Frequency(MHz) 5745

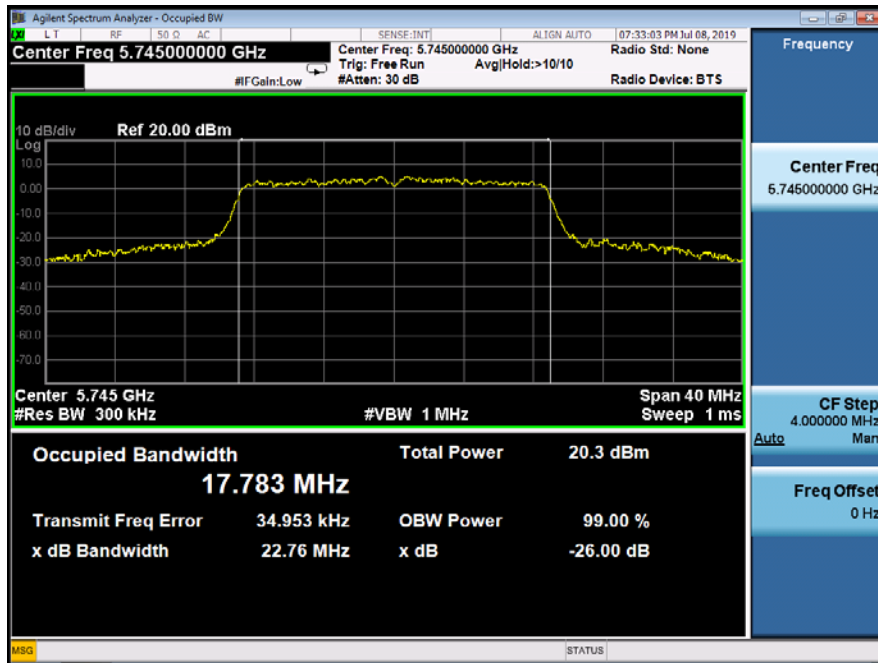

Emission Bandwidth&99% Occupied Bandwidth	UNII Band III
Test Model 802.11ac(VHT20) mode	Frequency(MHz) 5785

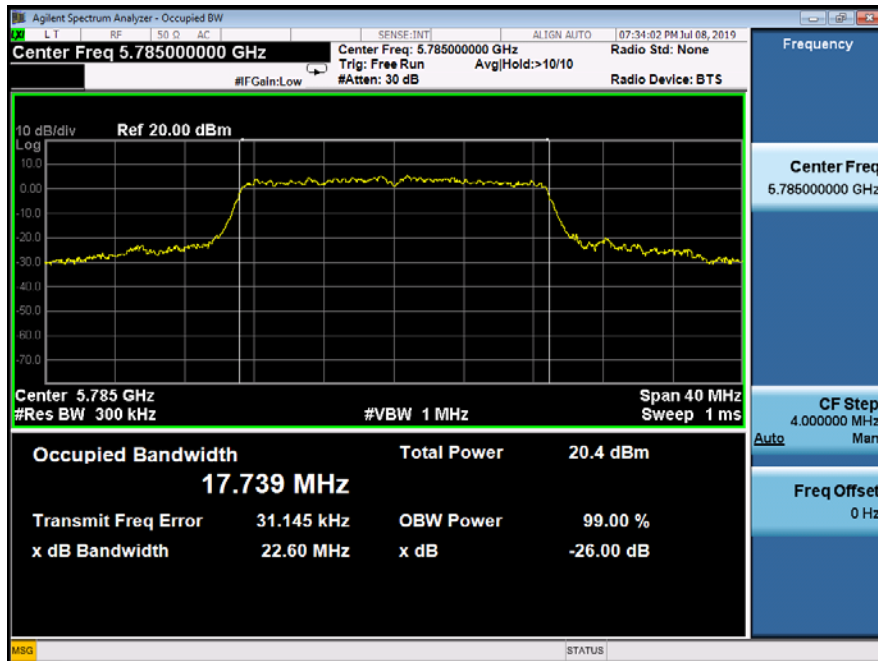



Emission Bandwidth&99% Occupied Bandwidth	UNII Band III
Test Model 802.11ac(VHT20) mode	Frequency(MHz) 5825

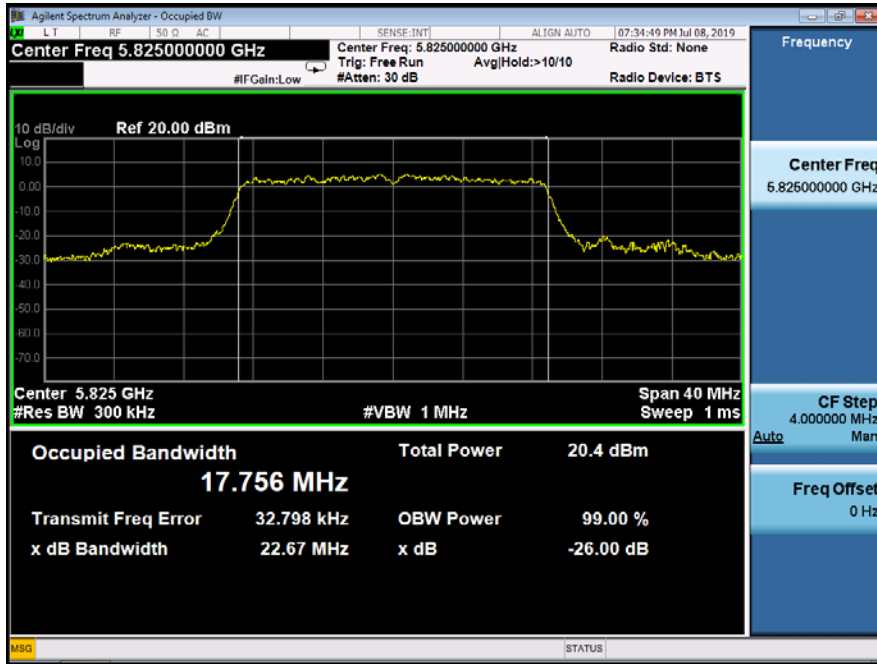

Emission Bandwidth&99% Occupied Bandwidth	UNII Band I
Test Model 802.11n(HT40) mode	Frequency(MHz) 5190

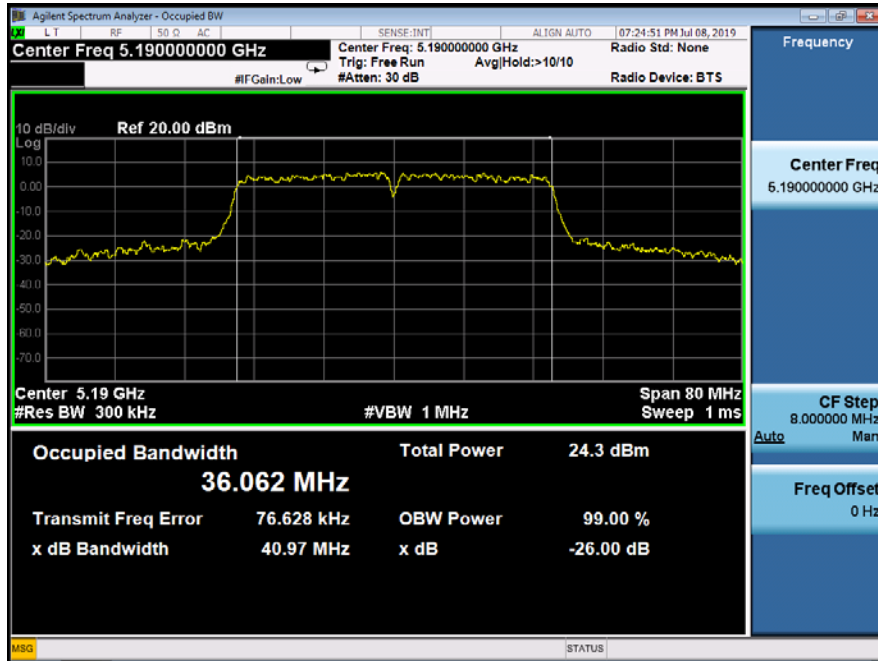

Emission Bandwidth&99% Occupied Bandwidth	UNII Band I
Test Model 802.11n(HT40) mode	Frequency(MHz) 5230

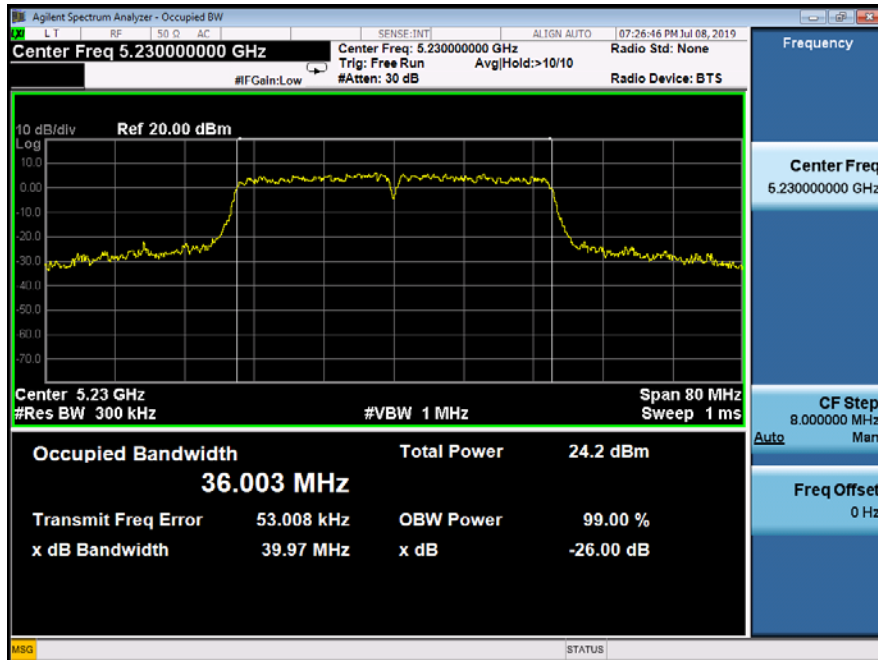

Emission Bandwidth&99% Occupied Bandwidth	UNII Band III
Test Model 802.11n(HT40) mode	Frequency(MHz) 5755

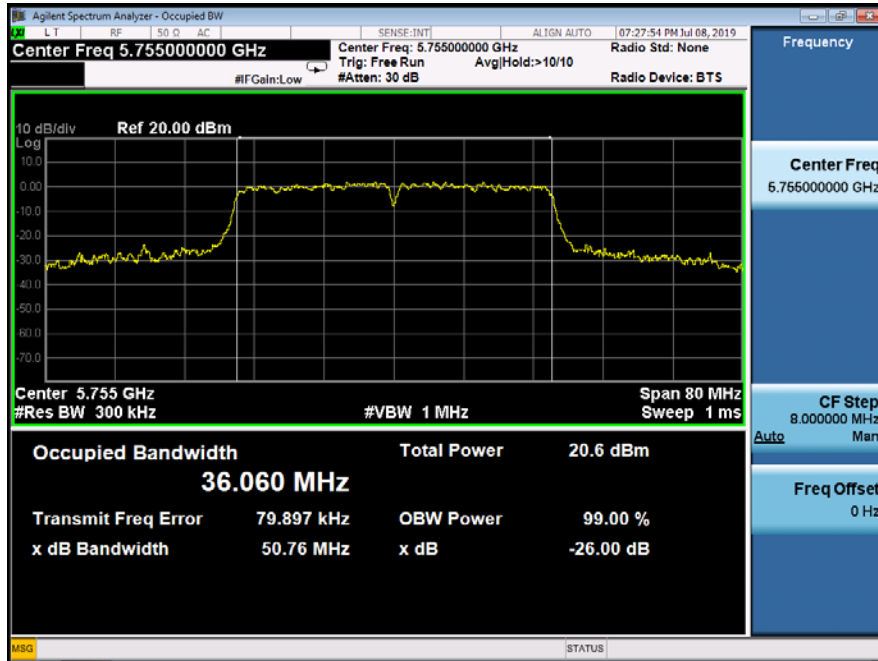

Emission Bandwidth&99% Occupied Bandwidth	UNII Band III
Test Model 802.11n(HT40) mode	Frequency(MHz) 5795

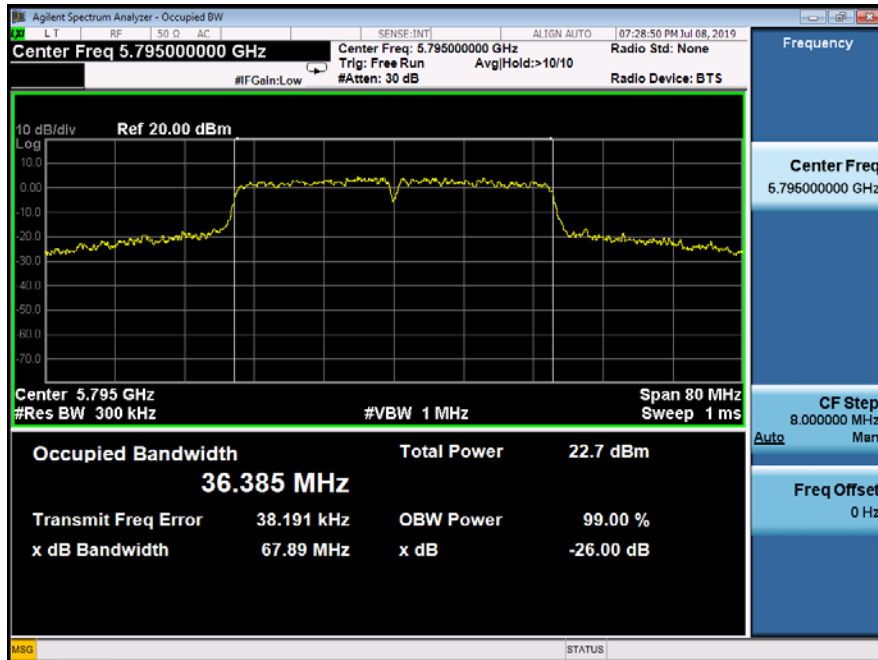

Emission Bandwidth&99% Occupied Bandwidth	UNII Band I
Test Model 802.11ac(VHT40) mode	Frequency(MHz) 5190

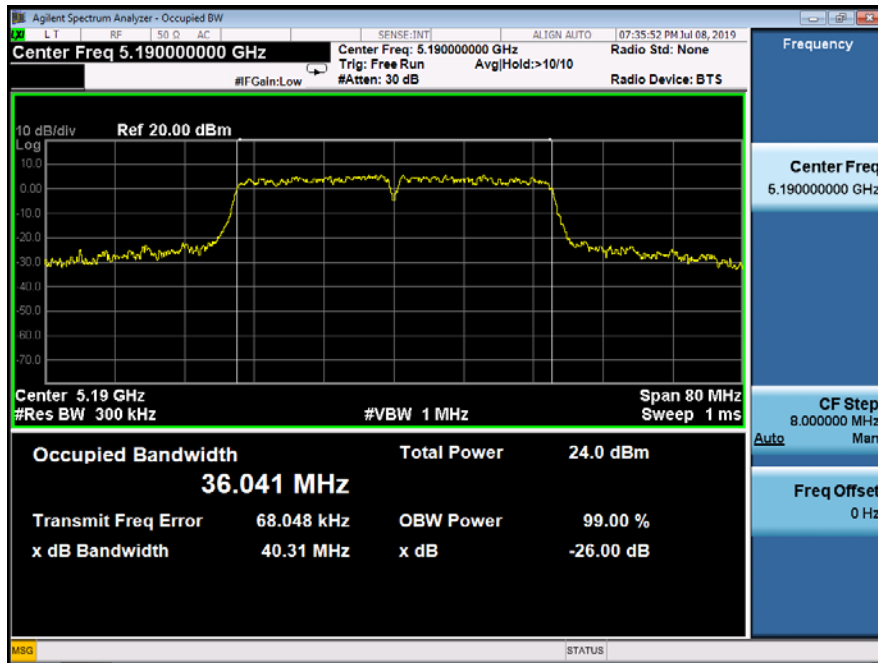

Emission Bandwidth&99% Occupied Bandwidth	UNII Band I
Test Model 802.11ac(VHT40) mode	Frequency(MHz) 5230

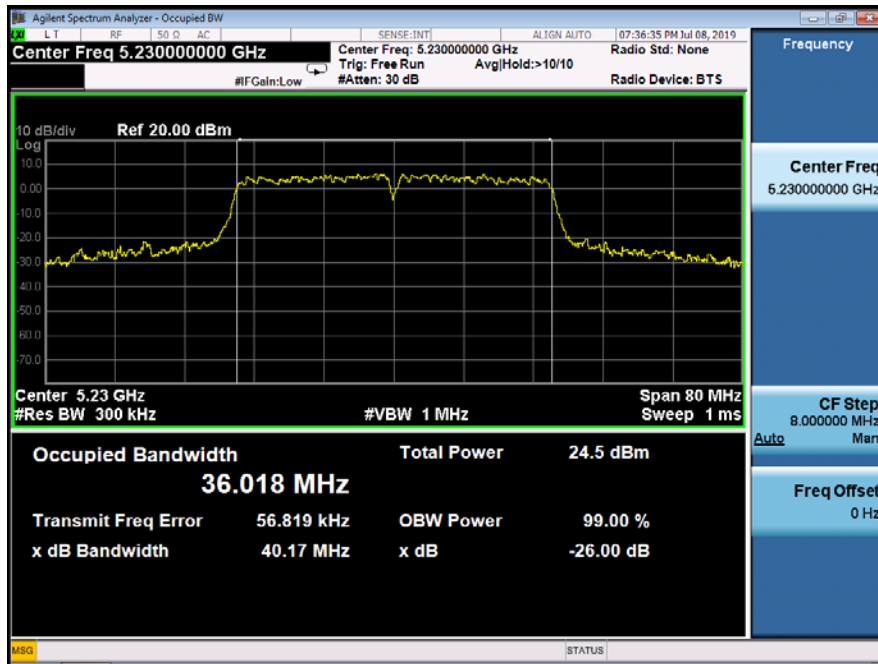

Emission Bandwidth&99% Occupied Bandwidth	UNII Band III
Test Model 802.11ac(VHT40) mode	Frequency(MHz) 5755

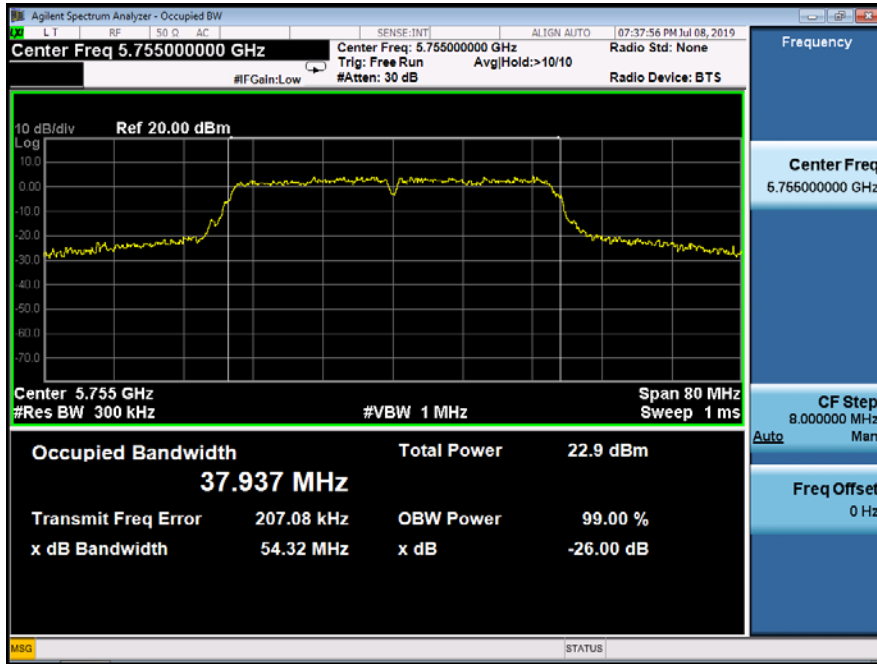

Emission Bandwidth&99% Occupied Bandwidth	UNII Band III
Test Model 802.11ac(VHT40) mode	Frequency(MHz) 5795

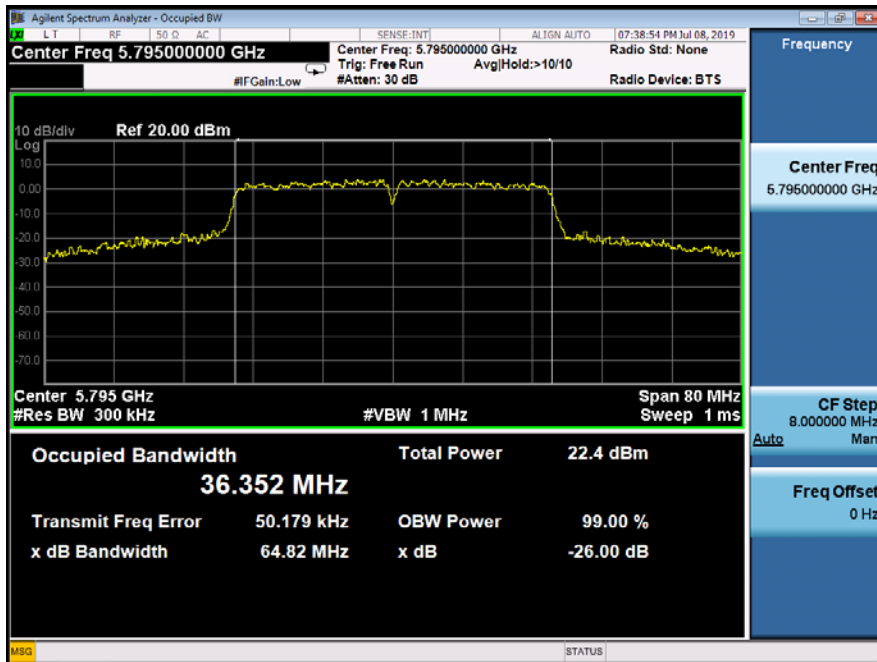

Emission Bandwidth&99% Occupied Bandwidth	UNII Band I
Test Model 802.11ac(VHT80) mode	Frequency(MHz) 5210

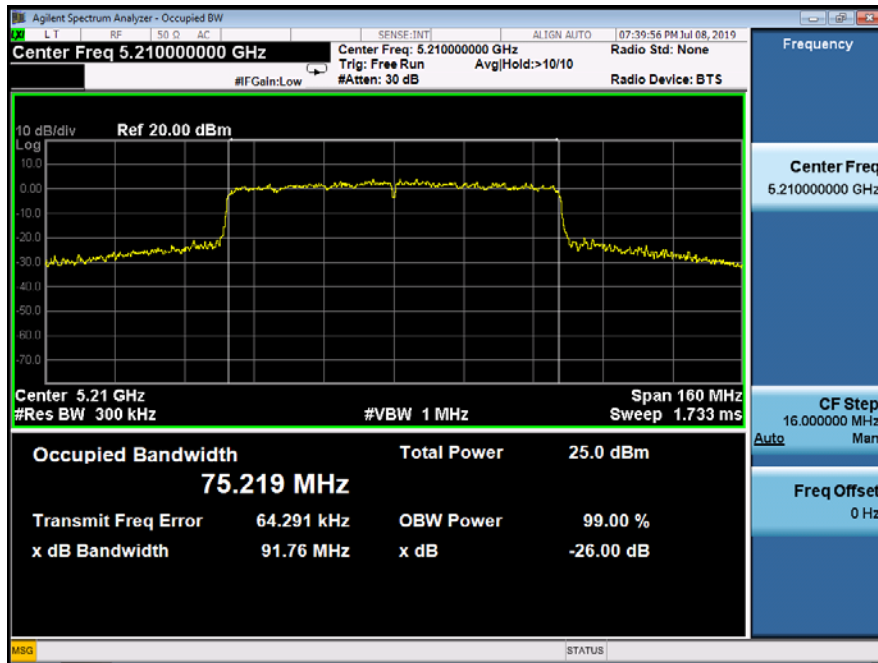

Emission Bandwidth&99% Occupied Bandwidth	UNII Band III
Test Model 802.11ac(VHT80) mode	Frequency(MHz) 5775

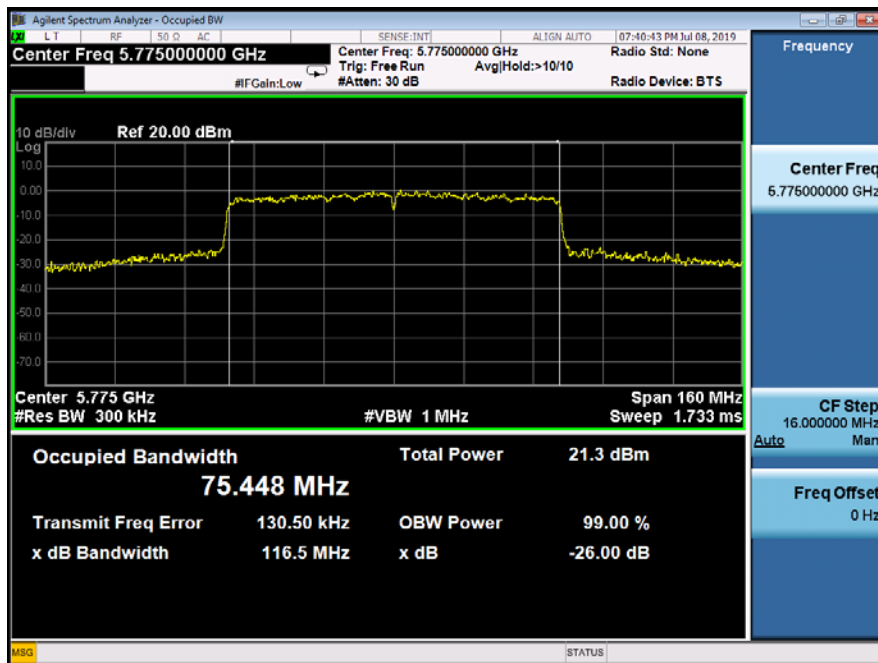

Minimum Emission Bandwidth	UNII Band III
Test Model 802.11a mode	Frequency(MHz) 5745

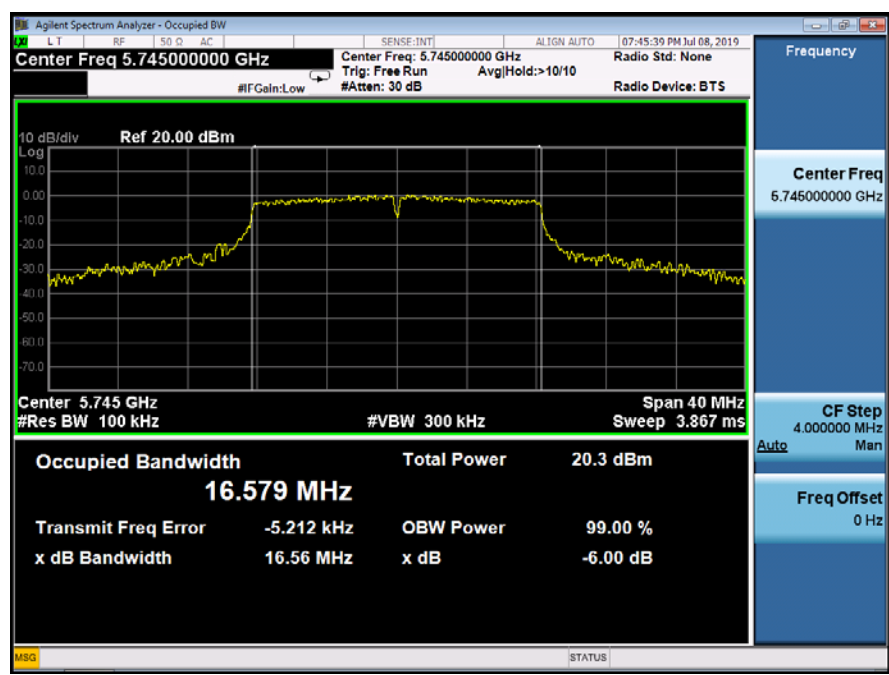

Minimum Emission Bandwidth	UNII Band III
Test Model 802.11a mode	Frequency(MHz) 5785

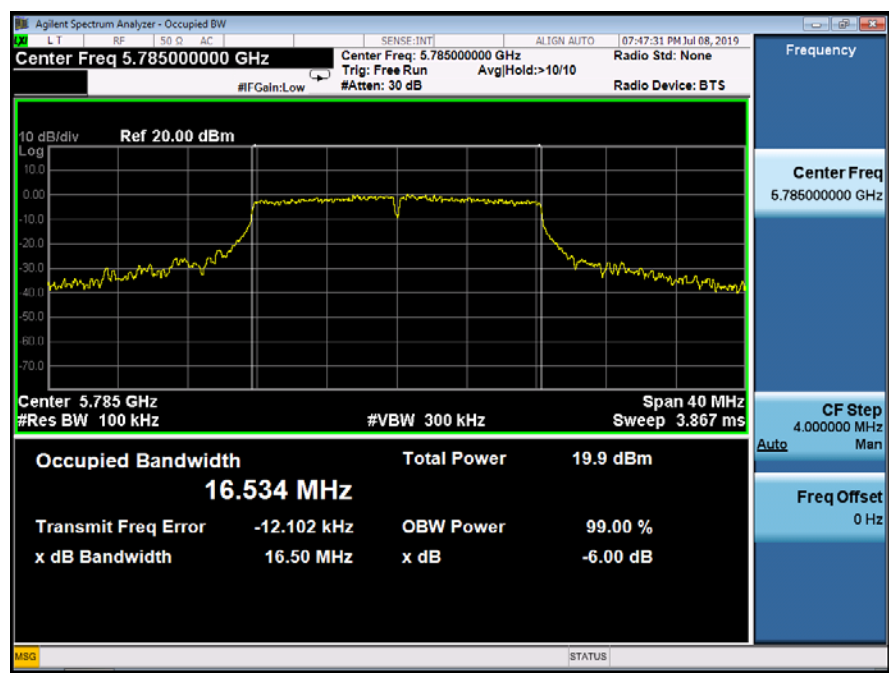

Minimum Emission Bandwidth	UNII Band III
Test Model 802.11a mode	Frequency(MHz) 5825

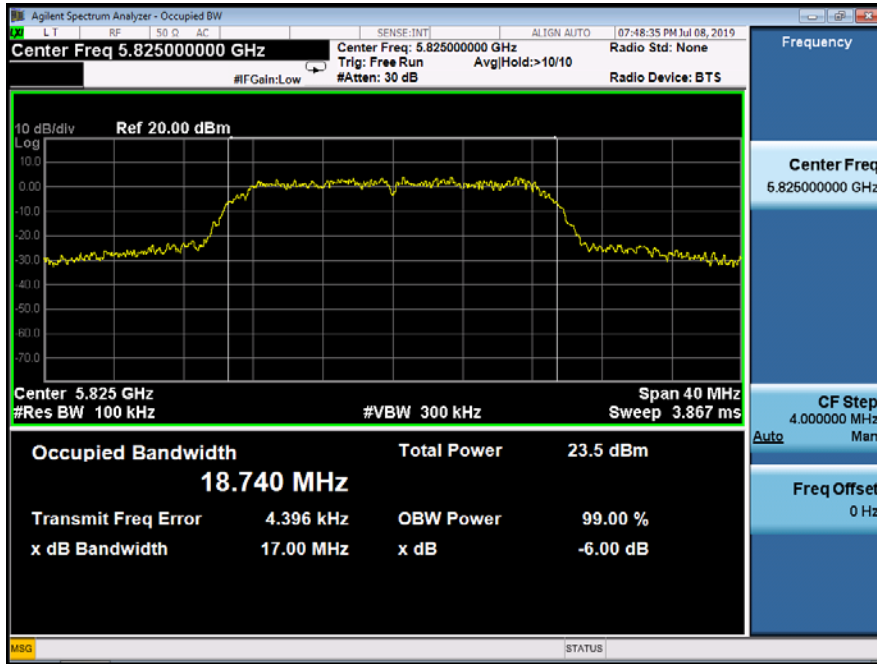



Minimum Emission Bandwidth		UNII Band III	
Test Model	802.11n(HT20) mode	Frequency(MHz)	5745

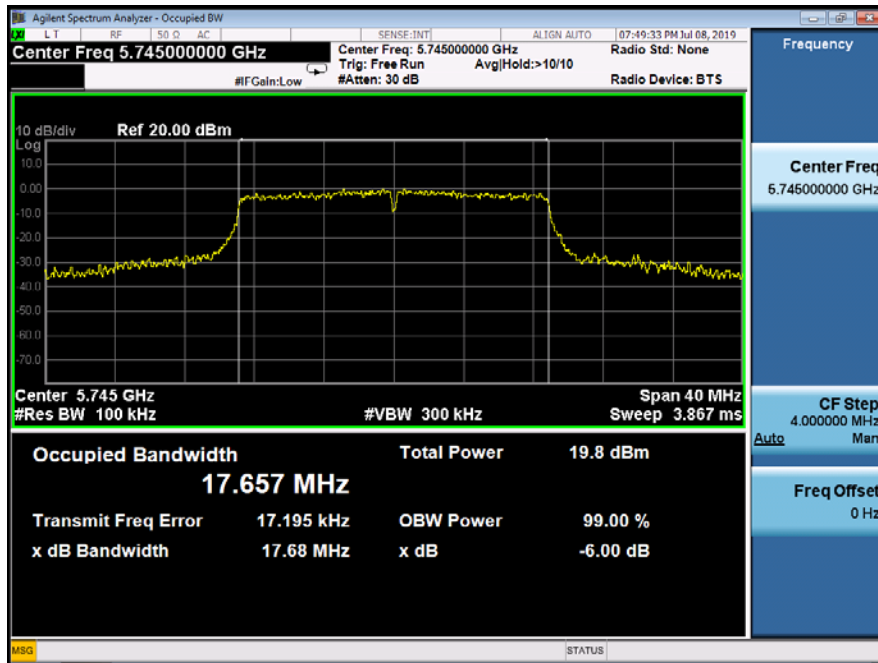

Minimum Emission Bandwidth		UNII Band III	
Test Model	802.11n(HT20) mode	Frequency(MHz)	5785

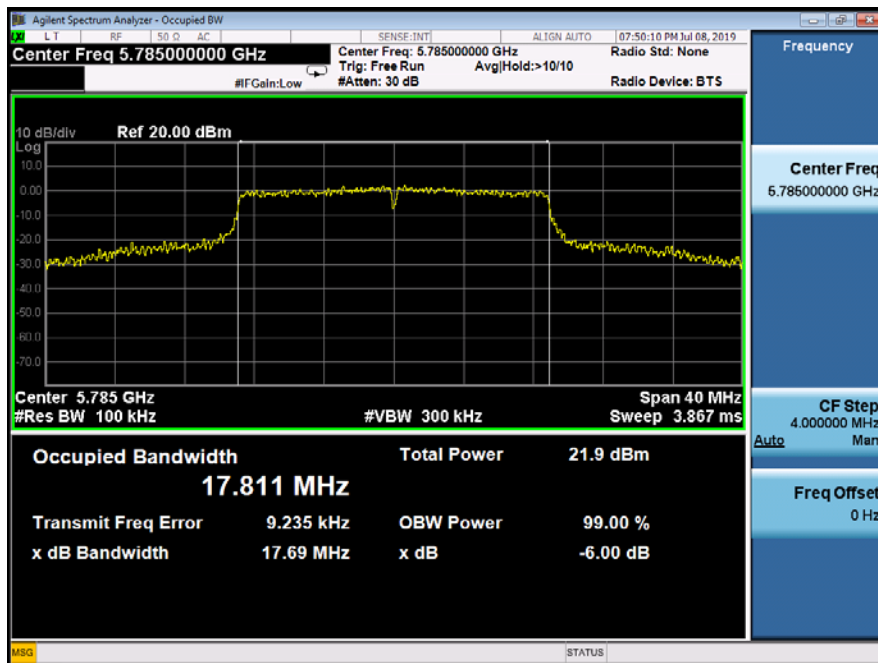

Minimum Emission Bandwidth	UNII Band III
Test Model 802.11n(VHT20) mode	Frequency(MHz) 5825

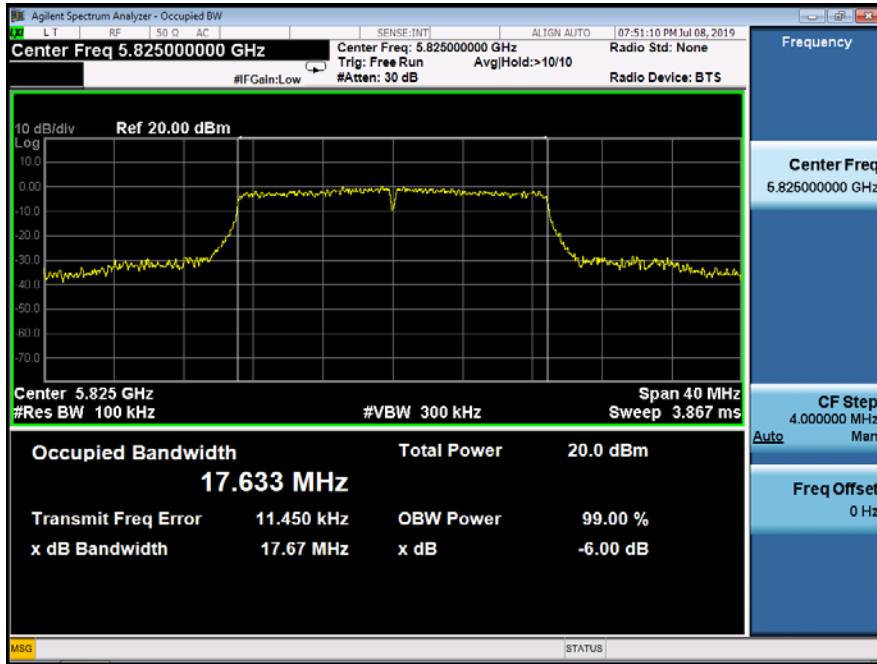

Minimum Emission Bandwidth	UNII Band III	
Test Model	802.11ac(VHT20) mode	Frequency(MHz)
		5745

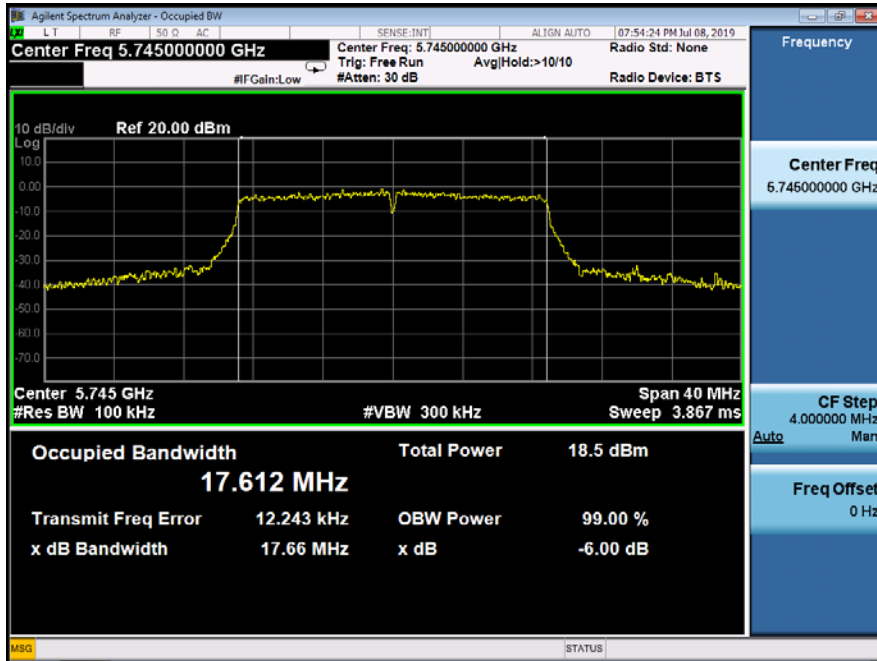

Minimum Emission Bandwidth	UNII Band III	
Test Model	802.11ac(VHT20) mode	Frequency(MHz)
		5785

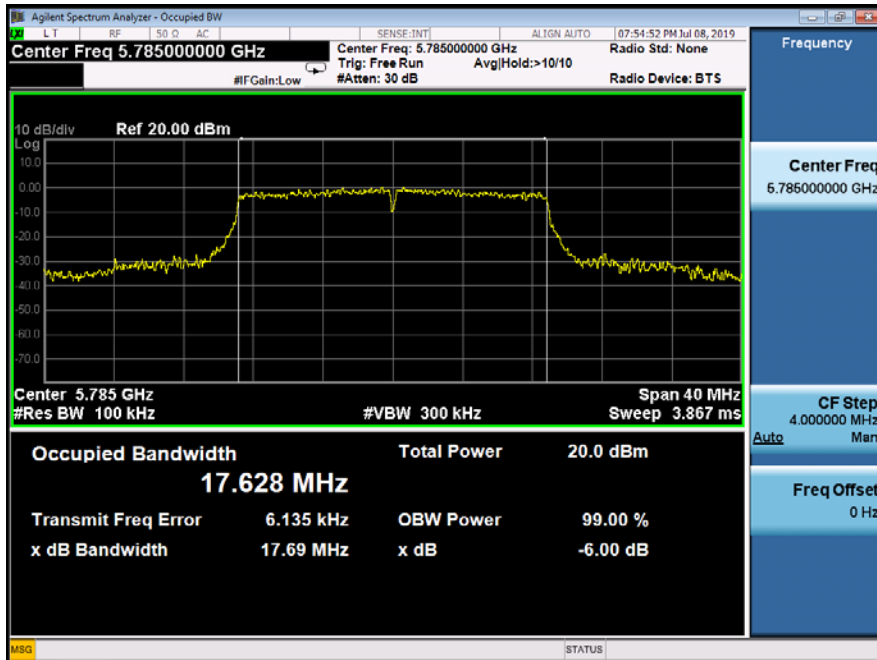

Minimum Emission Bandwidth	UNII Band III
Test Model 802.11ac(VHT20) mode	Frequency(MHz) 5825

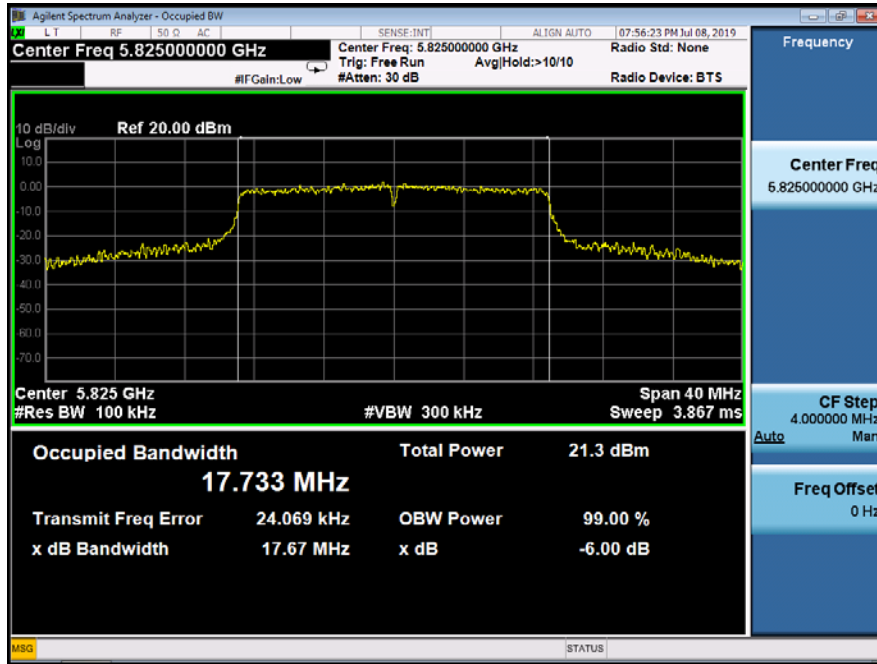

Minimum Emission Bandwidth	UNII Band III
Test Model 802.11n(HT40) mode	Frequency(MHz) 5755

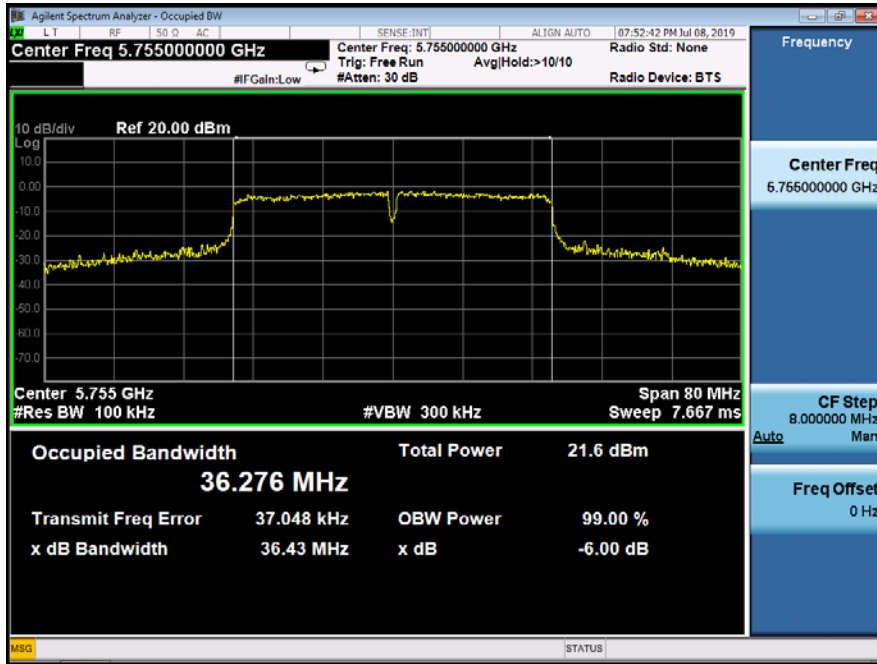

Minimum Emission Bandwidth	UNII Band III
Test Model 802.11n(HT40) mode	Frequency(MHz) 5795

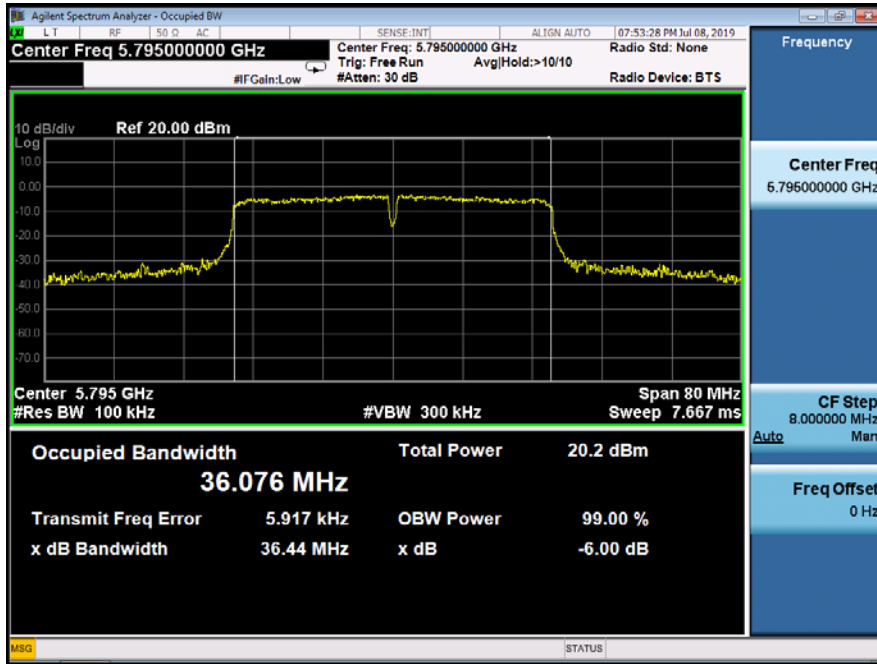

Minimum Emission Bandwidth	UNII Band III	
Test Model	802.11ac(VHT40) mode	Frequency(MHz)
		5755

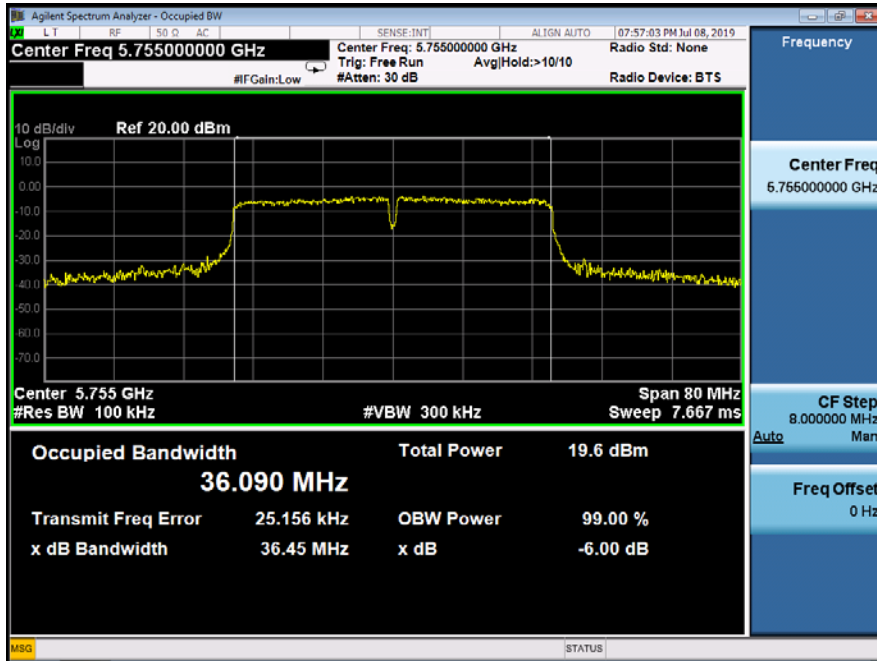

Minimum Emission Bandwidth	UNII Band III	
Test Model	802.11ac(VHT40) mode	Frequency(MHz)
		5795

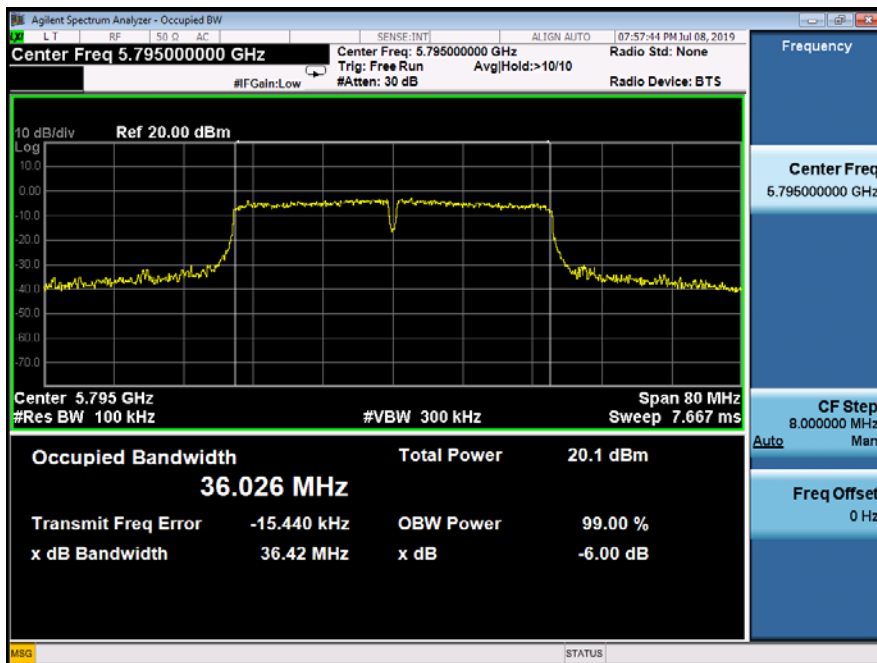

Minimum Emission Bandwidth	UNII Band III	
Test Model	802.11ac(VHT80) mode	5775
	Frequency(MHz)	

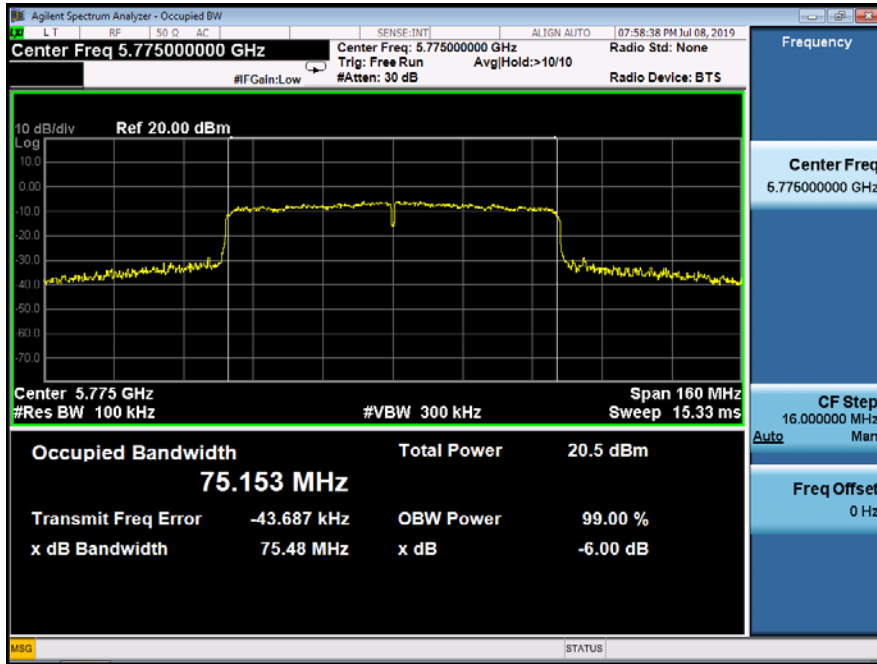



## 8.2 MAXIMUM CONDUCTED OUTPUT POWER

### 8.2.1 Applicable Standard

According to FCC Part 15.407(a)(1) for UNII Band I

According to FCC Part 15.407(a)(2) for UNII Band II-A and UNII Band II-C

According to FCC Part 15.407(a)(3) for UNII Band III

According to 789033 D02 Section II(E)

### 8.2.2 Conformance Limit

■ For the band 5.15-5.25 GHz,

(a) (1) (i) For an outdoor access point operating in the band 5.15-5.25 GHz, the maximum conducted output power over the frequency band of operation shall not exceed 1 W provided the maximum antenna gain does not exceed 6 dBi. In addition, the maximum power spectral density shall not exceed 17 dBm in any 1 megahertz band. If transmitting antennas of directional gain greater than 6 dBi are used, both the maximum conducted output power and the maximum power spectral density shall be reduced by the amount in dB that the directional gain of the antenna exceeds 6 dBi. The maximum e.i.r.p. at any elevation angle above 30 degrees as measured from the horizon must not exceed 125 mW (21 dBm).

(a) (1) (ii) For an indoor access point operating in the band 5.15-5.25 GHz, the maximum conducted output power over the frequency band of operation shall not exceed 1 W provided the maximum antenna gain does not exceed 6 dBi. In addition, the maximum power spectral density shall not exceed 17 dBm in any 1 megahertz band. If transmitting antennas of directional gain greater than 6 dBi are used, both the maximum conducted output power and the maximum power spectral density shall be reduced by the amount in dB that the directional gain of the antenna exceeds 6 dBi.

(a) (1) (iii) For fixed point-to-point access points operating in the band 5.15-5.25 GHz, the maximum conducted output power over the frequency band of operation shall not exceed 1 W. In addition, the maximum power spectral density shall not exceed 17 dBm in any 1 megahertz band. Fixed point-to-point U-NII devices may employ antennas with directional gain up to 23 dBi without any corresponding reduction in the maximum conducted output power or maximum power spectral density. For fixed point-to-point transmitters that employ a directional antenna gain greater than 23 dBi, a 1 dB reduction in maximum conducted output power and maximum power spectral density is required for each 1 dB of antenna gain in excess of 23 dBi. Fixed, point-to-point operations exclude the use of point-to-multipoint systems, omnidirectional applications, and multiple collocated transmitters transmitting the same information. The operator of the U-NII device, or if the equipment is professionally installed, the installer, is responsible for ensuring that systems employing high gain directional antennas are used exclusively for fixed, point-to-point operations.

(a) (1) (iv) For client devices in the 5.15-5.25 GHz band, the maximum conducted output power over the frequency band of operation shall not exceed 250 mW provided the maximum antenna gain does not exceed 6 dBi. In addition, the maximum power spectral density shall not exceed 11 dBm in any 1 megahertz band. If transmitting antennas of directional gain greater than 6 dBi are used, both the maximum conducted output power and the maximum power spectral density shall be reduced by the amount in dB that the directional gain of the antenna exceeds 6 dBi.

■ For the 5.25-5.35 GHz and 5.47-5.725 GHz bands

(a) (2) the maximum conducted output power over the frequency bands of operation shall not exceed the lesser of 250 mW or  $11 \text{ dBm} + 10 \log B$ , where B is the 26 dB emission bandwidth in megahertz. In addition, the maximum power spectral density shall not exceed 11 dBm in any 1 megahertz band. If transmitting antennas of directional gain greater than 6 dBi are used, both the maximum conducted output power and the maximum power spectral density shall be reduced by the amount in dB that the directional gain of the antenna exceeds 6 dBi.

■ For the band 5.725-5.85 GHz

(a) (3) For the band 5.725-5.85 GHz, the maximum conducted output power over the frequency band of operation shall not exceed 1 W. In addition, the maximum power spectral density shall not exceed 30 dBm in any 500-kHz band. If transmitting antennas of directional gain greater than 6 dBi are used, both the maximum conducted output power and the maximum power spectral density shall be reduced by the amount in dB that the directional gain of the antenna exceeds 6 dBi.

### 8.2.3 Test Configuration

Test according to clause 6.1 radio frequency test setup

### 8.2.4 Test Procedure

Method 1 For Normal Bandwidth 20MHz, 40MHz

The maximum average conducted output power can be measured using Method PM-G ( Measurement using an RF average power meter):

- a. The Transmitter output (antenna port) was connected to the power meter.
- b. Turn on the EUT and power meter and then record the power value.
- c. Repeat above procedures on all channels needed to be tested.

Method 2 For Normal Bandwidth 80MHz

Measurement of maximum conducted output power using a spectrum analyzer (Method SA-1 from KDB 789033)

- a. Set span to encompass the entire emission bandwidth (EBW) (or, alternatively, the entire 99% occupied bandwidth) of the signal.
- b. Set RBW = 1 MHz.
- c. Set VBW  $\geq$  3 MHz.
- d. Number of points in sweep  $\geq 2 \times$  span / RBW. (This ensures that bin-to-bin spacing is  $\leq$  RBW/2, so that narrowband signals are not lost between frequency bins.)
- e. Sweep time = auto.
- f. Detector = power averaging (rms)
- g. Trace average at least 100 traces in power averaging (rms) mode.
- h. Compute power by integrating the spectrum across the EBW (or, alternatively, the entire 99% occupied bandwidth) of the signal using the instrument's band power measurement function with band limits set equal to the EBW (or occupied bandwidth) band edges. If the instrument does not have a band power function, sum the spectrum levels (in power units) at 1 MHz intervals extending across the EBW (or, alternatively, the entire 99% occupied bandwidth) of the spectrum.

8.2.5 Test Results

		<input checked="" type="checkbox"/> 802.11a mode	
Temperature :	28 °C	Test By:	King Kong
Humidity :	65 %		

Band	Channel Number	Channel Freq. (MHz)	Conducted Output Power(dBm)		Limit (dBm)	Verdict
			Ant0	Ant1		
UNII Band I	CH36	5180	19.70	19.73	30.00	Pass
	CH40	5200	19.50	19.67	30.00	Pass
	CH48	5240	19.61	18.80	30.00	Pass
UNII Band III	CH149	5745	18.27	18.78	30.00	Pass
	CH157	5785	18.92	19.47	30.00	Pass
	CH165	5825	19.75	18.79	30.00	Pass
Note: N/A (Not Applicable)						

		<input checked="" type="checkbox"/> 802.11n(HT20) mode	
Temperature :	28 °C	Test By:	King Kong
Humidity :	65 %		

Band	Channel Number	Channel Freq. (MHz)	Conducted Output Power(dBm)			Limit (dBm)	Verdict
			Ant0	Ant1	Ant0+Ant1		
UNII Band I	CH36	5180	19.39	19.87	22.647	27.99	Pass
	CH40	5200	19.64	19.53	22.596	27.99	Pass
	CH48	5240	19.13	19.13	22.140	27.99	Pass
UNII Band III	CH149	5745	18.13	18.73	21.451	27.99	Pass
	CH157	5785	19.05	19.09	22.080	27.99	Pass
	CH165	5825	19.74	18.84	22.324	27.99	Pass

		<input checked="" type="checkbox"/> 802.11ac(VHT20) mode	
Temperature :	28 °C	Test By:	King Kong
Humidity :	65 %		

Band	Channel Number	Channel Freq. (MHz)	Conducted Output Power(dBm)			Limit (dBm)	Verdict
			Ant0	Ant1	Ant0+Ant1		
UNII Band I	CH36	5180	19.530	19.22	22.388	27.99	Pass
	CH40	5200	19.500	19.87	22.699	27.99	Pass
	CH48	5240	18.600	18.54	21.580	27.99	Pass
UNII Band III	CH149	5745	19.220	18.80	22.025	27.99	Pass
	CH157	5785	18.600	19.04	21.836	27.99	Pass
	CH165	5825	19.420	18.61	22.044	27.99	Pass

802.11n(HT40) mode

Temperature :	28 °C	Test By:	King Kong
Humidity :	65 %		

Band	Channel Number	Channel Freq. (MHz)	Conducted Output Power(dBm)			Limit (dBm)	Verdict
			Ant0	Ant1	Ant0+Ant1		
UNII	CH38	5190	19.18	19.68	22.447	27.99	Pass
Band I	CH46	5230	19.41	18.75	22.103	27.99	Pass
UNII	CH151	5755	18.29	19.22	21.790	27.99	Pass
Band III	CH159	5795	19.99	19.62	22.819	27.99	Pass

802.11ac(VHT40) mode

Temperature :	28 °C	Test By:	King Kong
Humidity :	65 %		

Band	Channel Number	Channel Freq. (MHz)	Conducted Output Power(dBm)			Limit (MHz)	Verdict
			Ant0	Ant1	Ant0+Ant1		
UNII	CH38	5190	19.59	19.66	22.635	27.99	Pass
Band I	CH46	5230	19.21	18.86	22.049	27.99	Pass
UNII	CH151	5755	19.32	18.87	22.111	27.99	Pass
Band III	CH159	5795	19.47	19.52	22.505	27.99	Pass

802.11ac(VHT80) mode

Temperature :	28 °C	Test By:	King Kong
Humidity :	65 %		

Band	Channel Number	Channel Freq. (MHz)	Conducted Output Power(dBm)			Limit (dBm)	Verdict
			Ant0	Ant1	Ant0+Ant1		
UNII	CH42	5210	18.49	19.45	22.007	27.99	Pass
Band I							
UNII	CH155	5775	19.06	19.59	22.343	27.99	Pass
Band III							

For 802.11ac (VHT80) Test Plots see the follow pages;

<b>MAXIMUM CONDUCTED OUTPUT POWER</b>		<b>UNII Band I</b>	
Test Model	802.11ac(VHT80) mode	Frequency(MHz)	5210
<b>Ant0</b>			

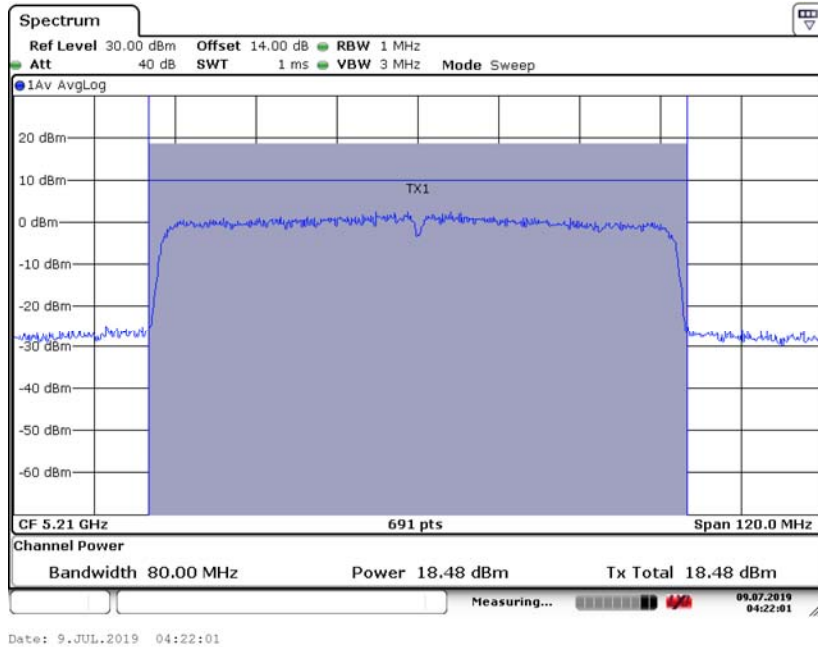

**Ant1**

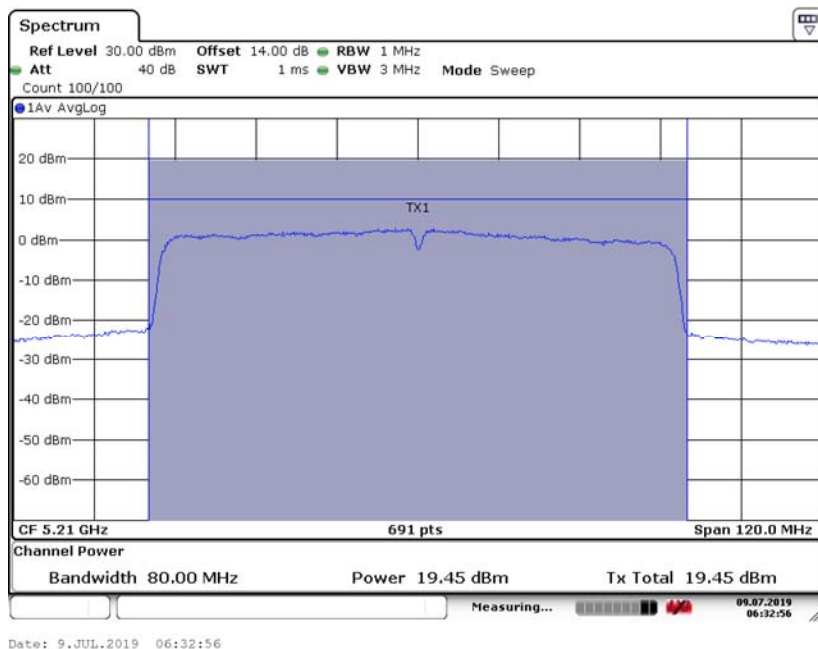

MAXIMUM CONDUCTED OUTPUT POWER		UNII Band III	
Test Model	802.11ac(VHT80) mode	Frequency(MHz)	5775
Ant0			

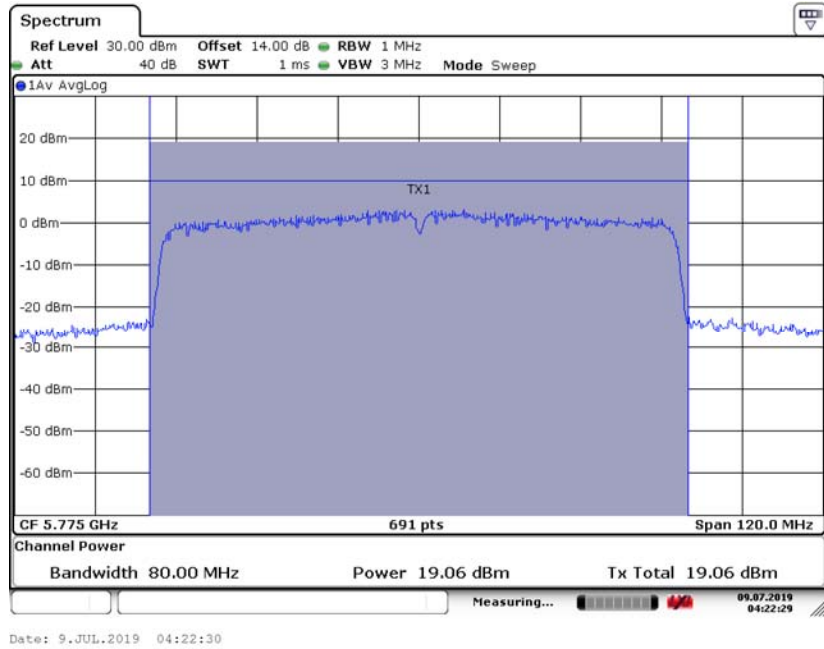

Ant1

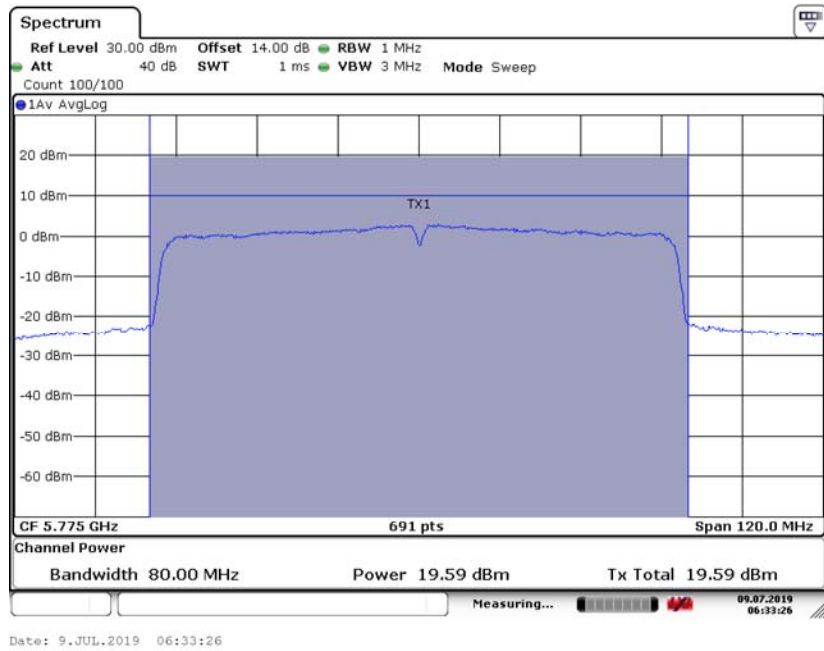

## 8.3 MAXIMUM PEAK POWER DENSITY

### 8.3.1 Applicable Standard

According to FCC Part 15.407(a)(1) for UNII Band I

According to FCC Part 15.407(a)(2) for UNII Band II-A and UNII Band II-C

According to FCC Part 15.407(a)(3) for UNII Band III

According to 789033 D02 Section II(F)

### 8.3.2 Conformance Limit

■ For the band 5.15-5.25 GHz,

(a) (1) (i) For an outdoor access point operating in the band 5.15-5.25 GHz, the maximum conducted output power over the frequency band of operation shall not exceed 1 W provided the maximum antenna gain does not exceed 6 dBi. In addition, the maximum power spectral density shall not exceed 17 dBm in any 1 megahertz band. If transmitting antennas of directional gain greater than 6 dBi are used, both the maximum conducted output power and the maximum power spectral density shall be reduced by the amount in dB that the directional gain of the antenna exceeds 6 dBi. The maximum e.i.r.p. at any elevation angle above 30 degrees as measured from the horizon must not exceed 125 mW (21 dBm).

(a) (1) (ii) For an indoor access point operating in the band 5.15-5.25 GHz, the maximum conducted output power over the frequency band of operation shall not exceed 1 W provided the maximum antenna gain does not exceed 6 dBi. In addition, the maximum power spectral density shall not exceed 17 dBm in any 1 megahertz band. If transmitting antennas of directional gain greater than 6 dBi are used, both the maximum conducted output power and the maximum power spectral density shall be reduced by the amount in dB that the directional gain of the antenna exceeds 6 dBi.

(a) (1) (iii) For fixed point-to-point access points operating in the band 5.15-5.25 GHz, the maximum conducted output power over the frequency band of operation shall not exceed 1 W. In addition, the maximum power spectral density shall not exceed 17 dBm in any 1 megahertz band. Fixed point-to-point U-NII devices may employ antennas with directional gain up to 23 dBi without any corresponding reduction in the maximum conducted output power or maximum power spectral density. For fixed point-to-point transmitters that employ a directional antenna gain greater than 23 dBi, a 1 dB reduction in maximum conducted output power and maximum power spectral density is required for each 1 dB of antenna gain in excess of 23 dBi. Fixed, point-to-point operations exclude the use of point-to-multipoint systems, omnidirectional applications, and multiple collocated transmitters transmitting the same information. The operator of the U-NII device, or if the equipment is professionally installed, the installer, is responsible for ensuring that systems employing high gain directional antennas are used exclusively for fixed, point-to-point operations.

(a) (1) (iv) For client devices in the 5.15-5.25 GHz band, the maximum conducted output power over the frequency band of operation shall not exceed 250 mW provided the maximum antenna gain does not exceed 6 dBi. In addition, the maximum power spectral density shall not exceed 11 dBm in any 1 megahertz band. If transmitting antennas of directional gain greater than 6 dBi are used, both the maximum conducted output power and the maximum power spectral density shall be reduced by the amount in dB that the directional gain of the antenna exceeds 6 dBi.

■ For the 5.25-5.35 GHz and 5.47-5.725 GHz bands

(b) (2) the maximum conducted output power over the frequency bands of operation shall not exceed the lesser of 250 mW or  $11 \text{ dBm} + 10 \log B$ , where B is the 26 dB emission bandwidth in megahertz. In addition, the maximum power spectral density shall not exceed 11 dBm in any 1 megahertz band. If transmitting antennas of directional gain greater than 6 dBi are used, both the maximum conducted output power and the maximum power spectral density shall be reduced by the amount in dB that the directional gain of the antenna exceeds 6 dBi.

■ For the band 5.725-5.85 GHz

(a) (3) For the band 5.725-5.85 GHz, the maximum conducted output power over the frequency band of operation shall not exceed 1 W. In addition, the maximum power spectral density shall not exceed 30 dBm in any 500-kHz band. If transmitting antennas of directional gain greater than 6 dBi are used, both the maximum conducted output power and the maximum power spectral density shall be reduced by the amount in dB that the directional gain of the antenna exceeds 6 dBi.

### 8.3.3 Test Configuration

Test according to clause 6.1 radio frequency test setup

### 8.3.4 Test Procedure

Methods refer to FCC KDB 789033

1) Create an average power spectrum for the EUT operating mode being tested by following the instructions in section E)2) for measuring maximum conducted output power using a spectrum analyzer or EMI receiver: select the appropriate test method (SA-3, or alternatives to each) and apply it up to, but not including, the step labeled, "Compute power...".

2) Use the peak search function on the instrument to find the peak of the spectrum.

3) The result is the PPSD.

4) The above procedures make use of 500kHz resolution bandwidth to satisfy the 500kHz measurement bandwidth specified in the 15.407(a)(5). That rule section also permits use of resolution bandwidths less than 1 MHz "provided that the measured power is integrated to show the total power over the measurement bandwidth" (i.e., 1 MHz). If measurements are performed using a reduced resolution bandwidth and integrated over 500kHz bandwidth

Note: As a practical matter, it is recommended to use reduced RBW of 500 kHz for the sections 5.c) and 5.d) above, since RBW=500 kHz is available on nearly all spectrum analyzers.



### 8.3.5 Test Results

		<input checked="" type="checkbox"/> 802.11a mode	
Temperature :	28 °C	Test By:	King Kong
Humidity :	65 %		

Band	Channel Number	Channel Freq. (MHz)	Power Spectral Density		Limit	Verdict
			Ant0	Ant1		
UNII Band I	CH36	5180	8.43	8.61	≤17dBm/1MHz	Pass
	CH40	5200	8.70	8.59	≤17dBm/1MHz	Pass
	CH48	5240	8.19	7.14	≤17dBm/1MHz	Pass
UNII Band III	CH149	5745	4.88	4.20	≤30dBm/500KHz	Pass
	CH157	5785	5.14	5.07	≤30dBm/500KHz	Pass
	CH165	5825	6.57	5.50	≤30dBm/500KHz	Pass

		<input checked="" type="checkbox"/> 802.11n(HT20) mode	
Temperature :	28 °C	Test By:	King Kong
Humidity :	65 %		

Band	Channel Number	Channel Freq. (MHz)	Power Spectral Density			Limit	Verdict
			Ant0	Ant1	Ant0+Ant1		
UNII Band I	CH36	5180	7.47	8.29	10.910	≤14.99dBm/1MHz	Pass
	CH40	5200	7.99	7.88	10.946	≤14.99dBm/1MHz	Pass
	CH48	5240	7.36	7.41	10.395	≤14.99dBm/1MHz	Pass
UNII Band III	CH149	5745	5.49	3.77	7.725	≤27.99dBm/500KHz	Pass
	CH157	5785	6.46	4.33	8.535	≤27.99dBm/500KHz	Pass
	CH165	5825	5.04	5.01	8.035	≤27.99dBm/500KHz	Pass

		<input checked="" type="checkbox"/> 802.11ac(VHT20) mode	
Temperature :	28 °C	Test By:	King Kong
Humidity :	65 %		

Band	Channel Number	Channel Freq. (MHz)	Power Spectral Density			Limit	Verdict
			Ant0	Ant1	Ant0+Ant1		
UNII Band I	CH36	5180	7.00	8.05	10.567	≤14.99dBm/1MHz	Pass
	CH40	5200	6.58	8.80	10.841	≤14.99dBm/1MHz	Pass
	CH48	5240	7.56	6.98	10.290	≤14.99dBm/1MHz	Pass
UNII Band III	CH149	5745	4.47	4.49	7.490	≤27.99dBm/500KHz	Pass
	CH157	5785	5.04	5.07	8.065	≤27.99dBm/500KHz	Pass
	CH165	5825	6.18	4.74	8.530	≤27.99dBm/500KHz	Pass

☑ 802.11n(VHT40) mode

Temperature : 28 °C

Test By:

King Kong

Humidity : 65 %

Band	Channel Number	Channel Freq. (MHz)	Power Spectral Density			Limit	Verdict
			Ant0	Ant1	Ant0+Ant1		
UNII Band I	CH38	5190	4.32	5.31	7.853	≤14.99dBm/1MHz	Pass
	CH46	5230	4.46	4.69	7.587	≤14.99dBm/1MHz	Pass
UNII Band III	CH151	5755	2.50	1.18	4.900	≤27.99dBm/500KHz	Pass
	CH159	5795	1.93	2.51	5.240	≤27.99dBm/500KHz	Pass

☑ 802.11ac(VHT40) mode

Temperature : 28 °C

Test By:

King Kong

Humidity : 65 %

Band	Channel Number	Channel Freq. (MHz)	Power Spectral Density			Limit	Verdict
			Ant0	Ant1	Ant0+Ant1		
UNII Band I	CH38	5190	3.95	5.29	7.682	≤14.99dBm/1MHz	Pass
	CH46	5230	3.92	4.75	7.365	≤14.99dBm/1MHz	Pass
UNII Band III	CH151	5755	2.44	1.56	5.033	≤27.99dBm/500KHz	Pass
	CH159	5795	1.85	2.22	5.049	≤27.99dBm/500KHz	Pass

☑ 802.11ac(VHT80) mode

Temperature : 28 °C

Test By:

King Kong

Humidity : 65 %

Band	Channel Number	Channel Freq. (MHz)	Power Spectral Density			Limit	Verdict
			Ant0	Ant1	Ant0+Ant1		
UNII Band I	CH42	5210	1.76	2.23	5.012	≤14.99dBm/1MHz	Pass
UNII Band III	CH155	5775	-0.45	-1.39	2.116	≤27.99dBm/500KHz	Pass

**A. Antenna 0**

Power Spectral Density	UNII Band I
Test Model 802.11a	Frequency(MHz) 5180

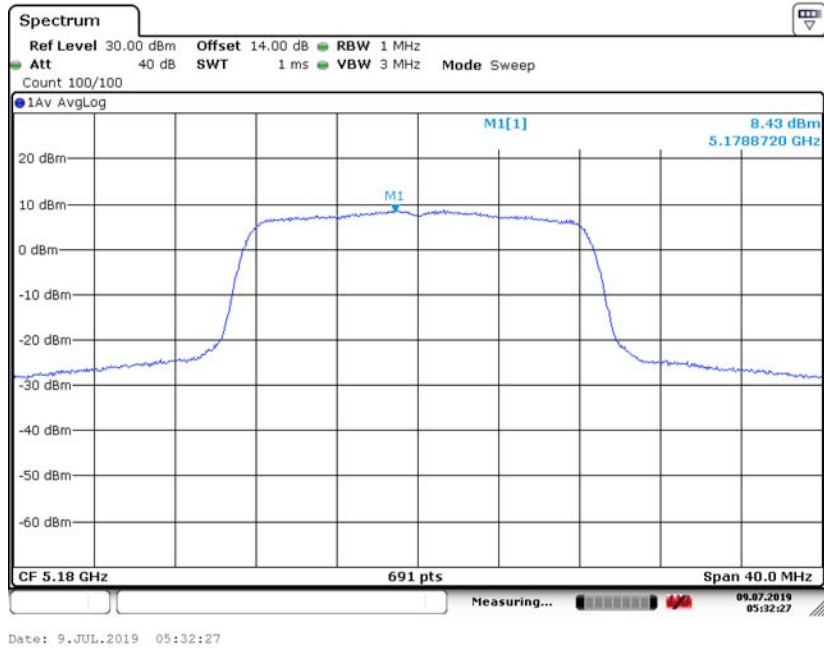

Power Spectral Density	UNII Band I
Test Model 802.11a	Frequency(MHz) 5200



Power Spectral Density	UNII Band I
Test Model 802.11a	Frequency(MHz) 5240

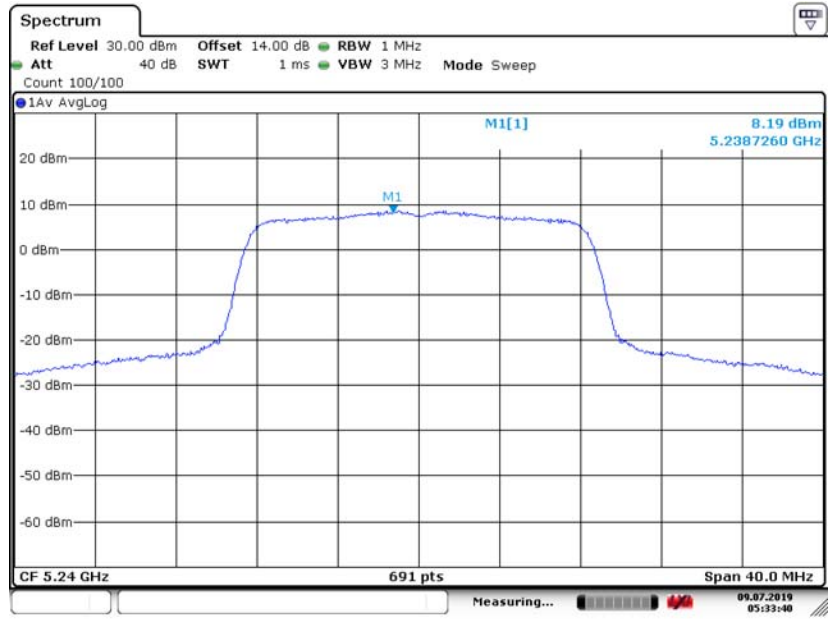

Date: 9.JUL.2019 05:33:40

Power Spectral Density	UNII Band III
Test Model 802.11a	Frequency(MHz) 5745

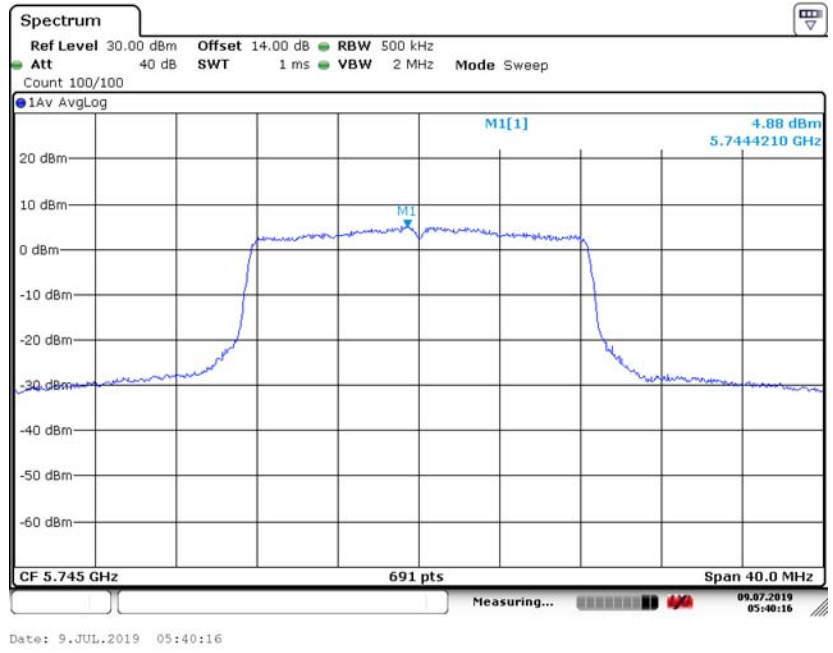

Power Spectral Density	UNII Band III
Test Model 802.11a	Frequency(MHz) 5785

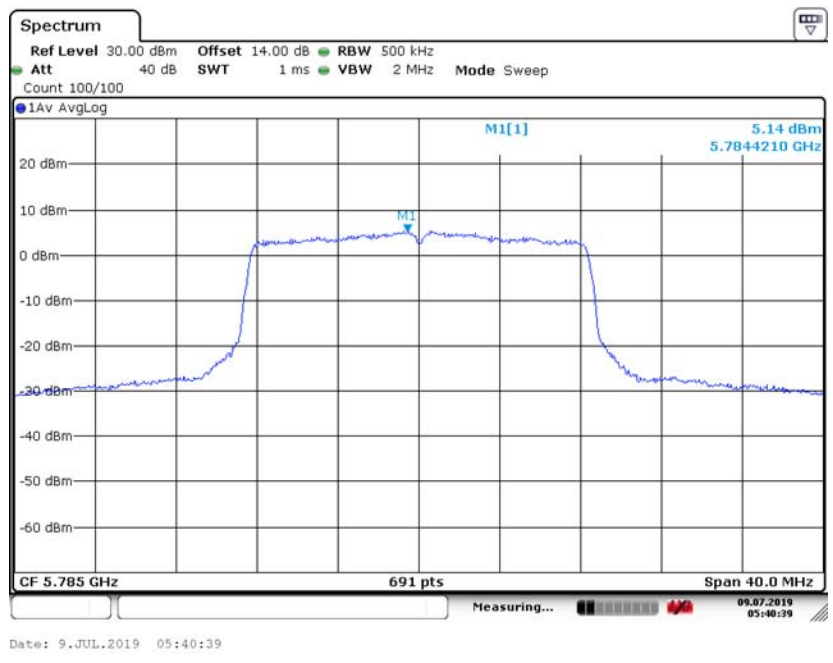

Power Spectral Density	UNII Band III
Test Model 802.11a	Frequency(MHz) 5825

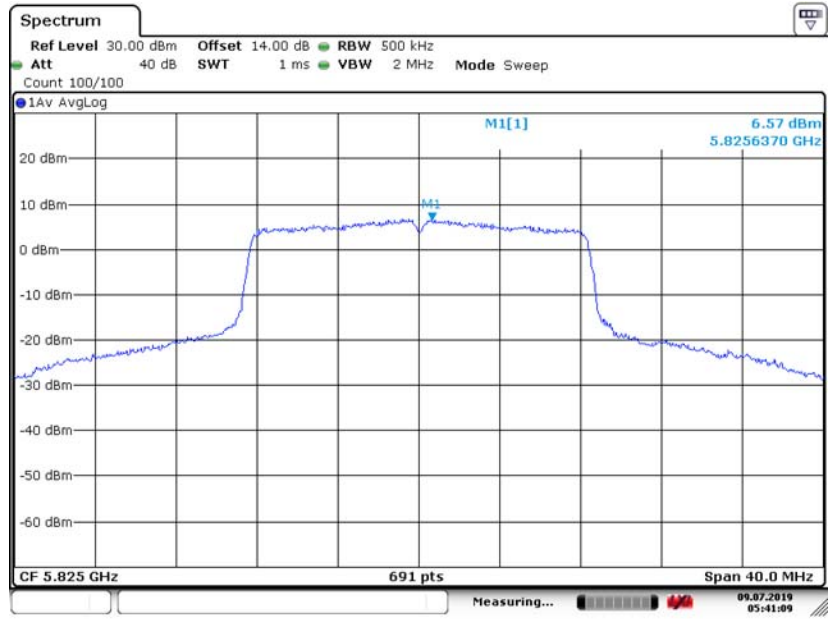

Date: 9.JUL.2019 05:41:09

Power Spectral Density	UNII Band I
Test Model 802.11n(HT20) mode	Frequency(MHz) 5180

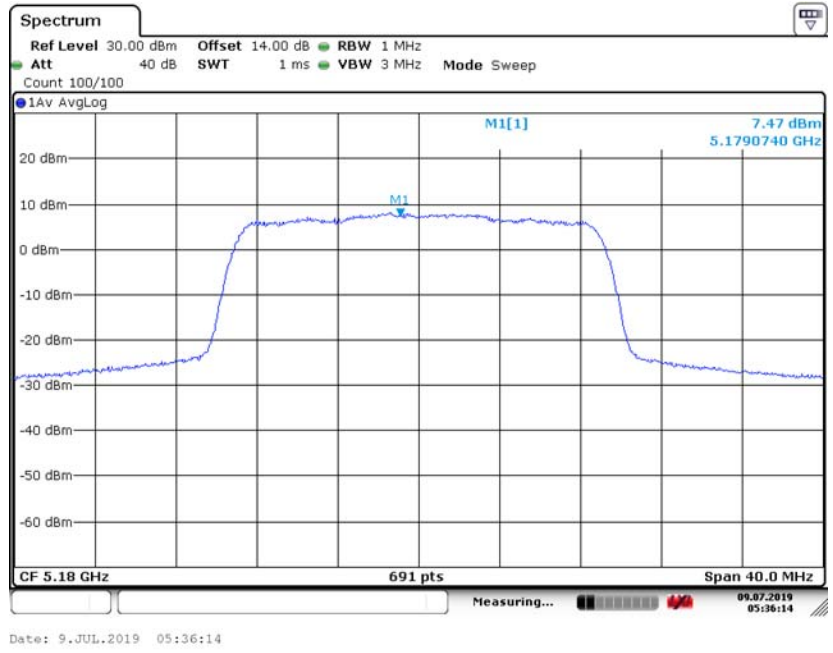

Power Spectral Density	UNII Band I
Test Model 802.11n(HT20) mode	Frequency(MHz) 5200



Power Spectral Density	UNII Band I
Test Model 802.11n(HT20) mode	Frequency(MHz) 5240

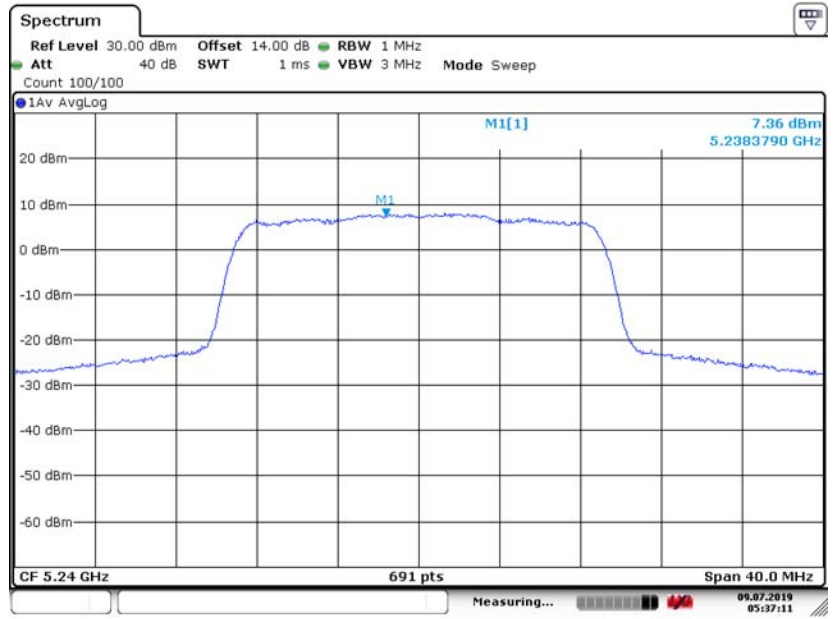

Date: 9.JUL.2019 05:37:11



Power Spectral Density	UNII Band III
Test Model 802.11n(HT20) mode	Frequency(MHz) 5745

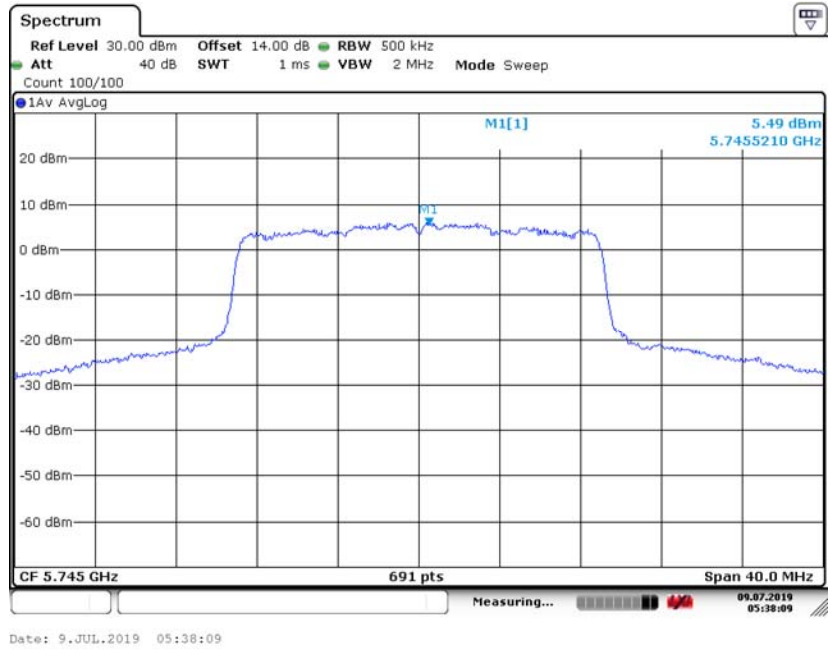

Power Spectral Density	UNII Band III
Test Model 802.11n(HT20) mode	Frequency(MHz) 5785

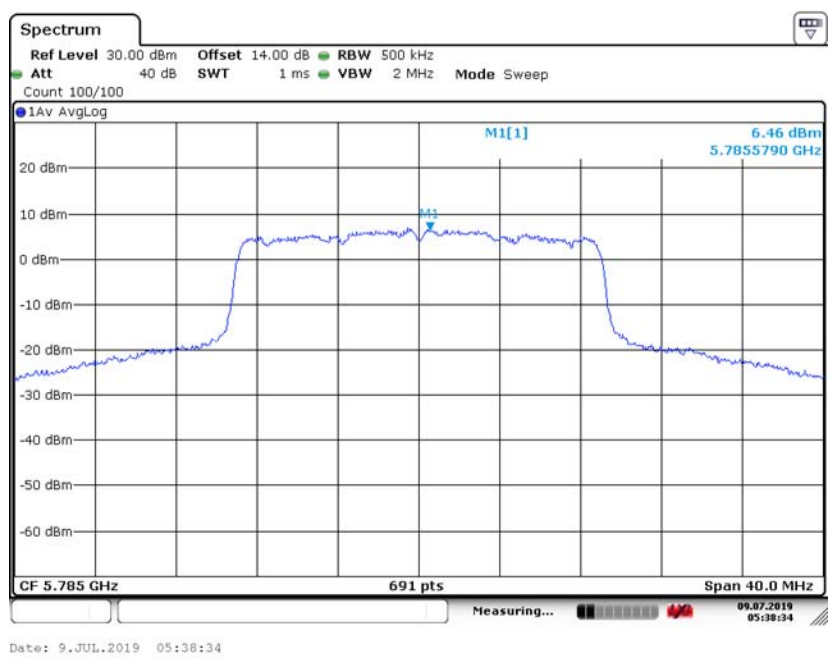

Power Spectral Density	UNII Band III
Test Model 802.11n(HT20) mode	Frequency(MHz) 5825

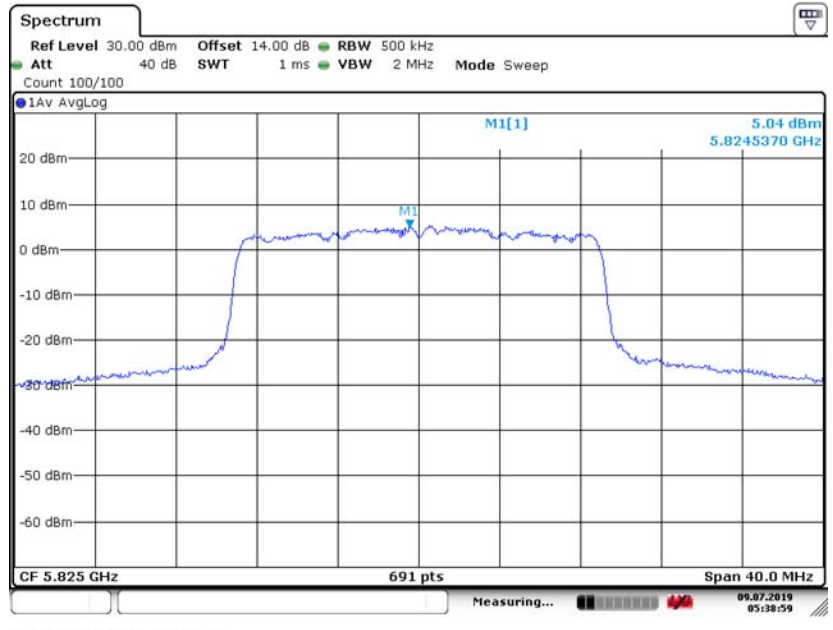

Date: 9.JUL.2019 05:38:59

Power Spectral Density	UNII Band I
Test Model 802.11ac(VHT20) mode	Frequency(MHz) 5180

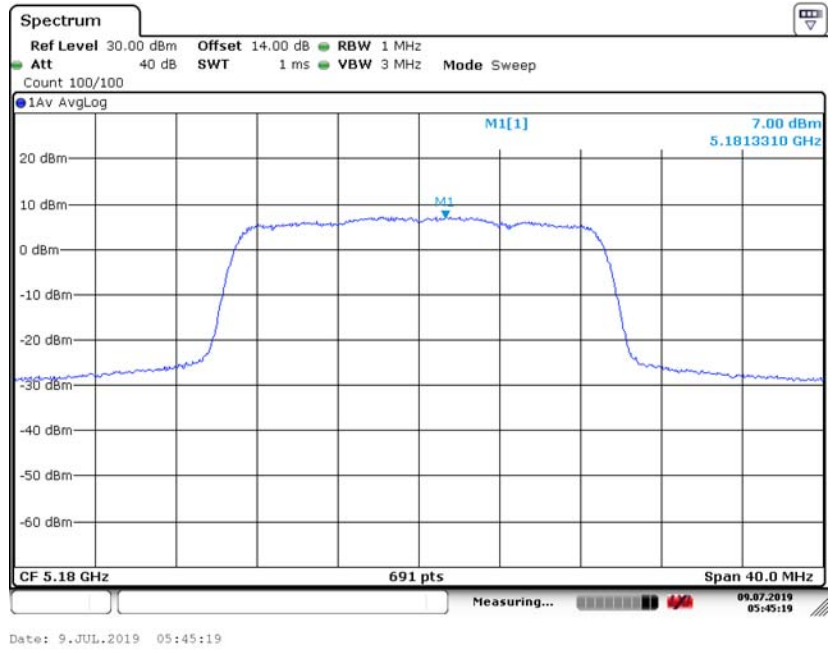

Power Spectral Density	UNII Band I
Test Model 802.11ac(VHT20) mode	Frequency(MHz) 5200

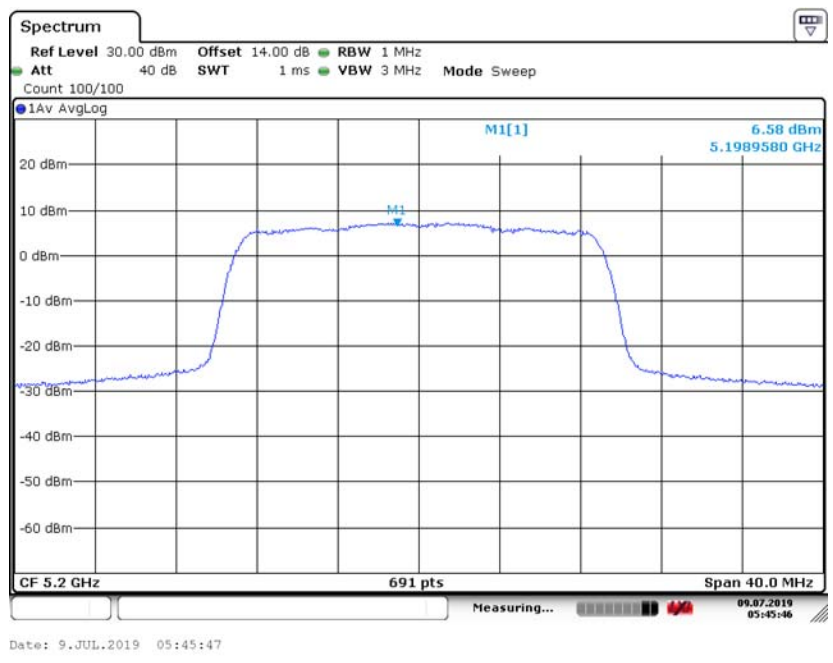

Power Spectral Density	UNII Band I
Test Model 802.11ac(VHT20) mode	Frequency(MHz) 5240

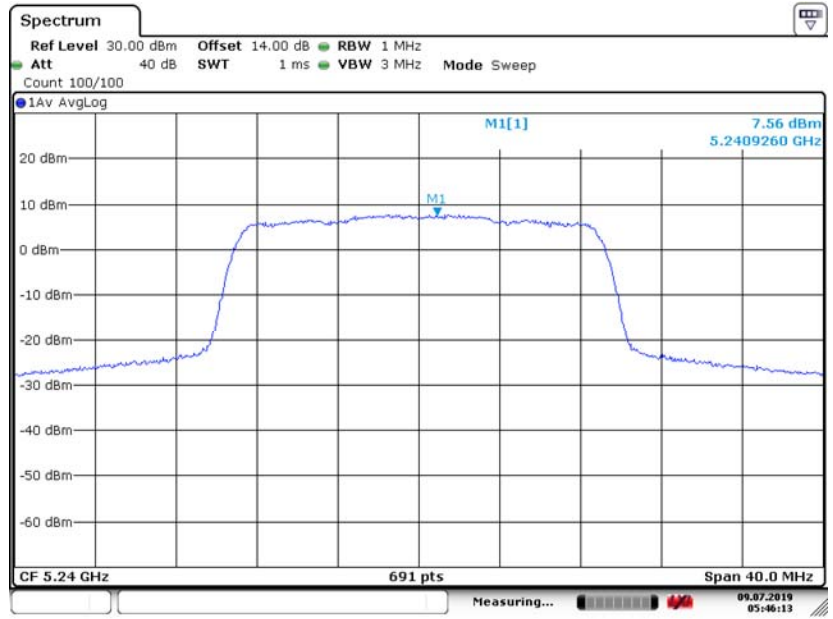

Date: 9.JUL.2019 05:46:13

Power Spectral Density	UNII Band III
Test Model 802.11ac(VHT20) mode	Frequency(MHz) 5745

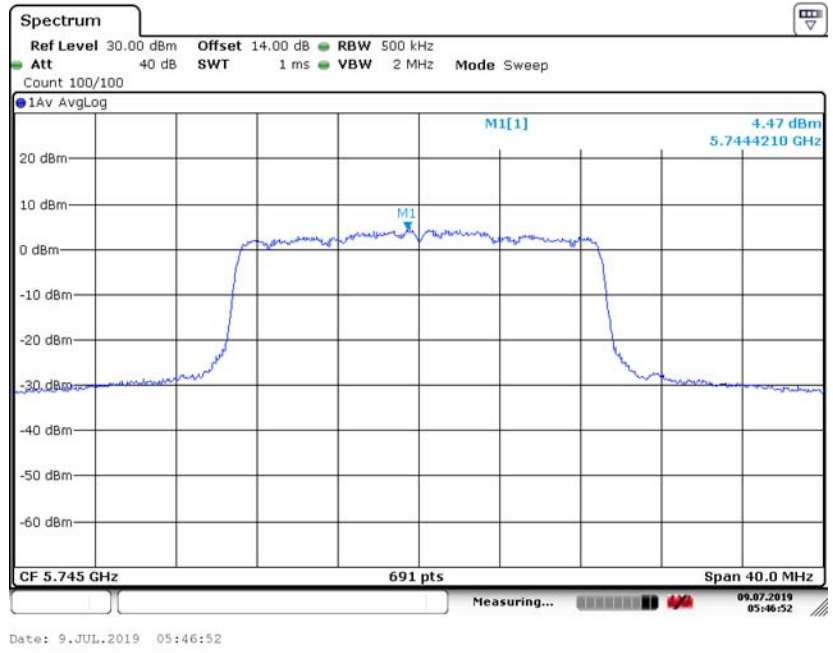

Power Spectral Density	UNII Band III
Test Model 802.11ac(VHT20) mode	Frequency(MHz) 5785

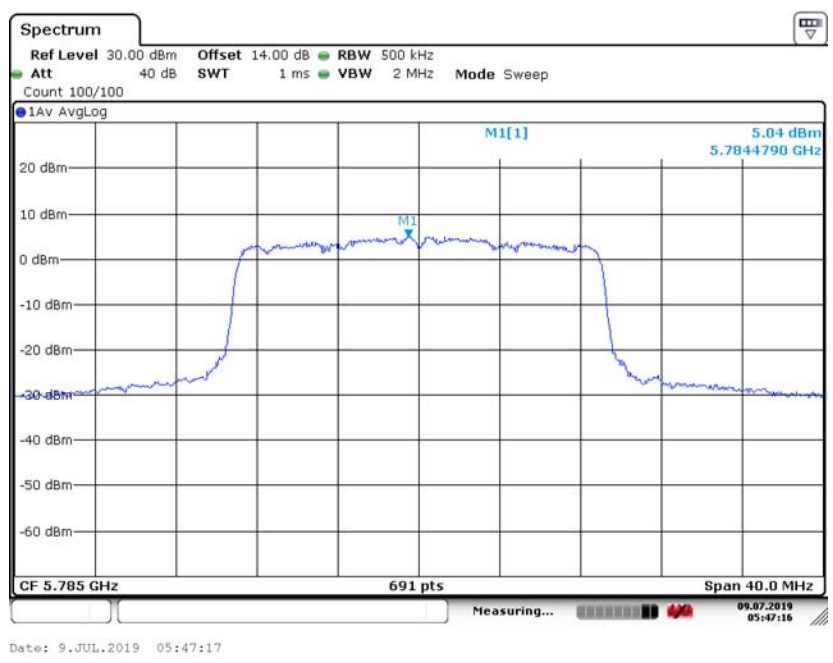

Power Spectral Density	UNII Band III
Test Model 802.11ac(VHT20) mode	Frequency(MHz) 5825

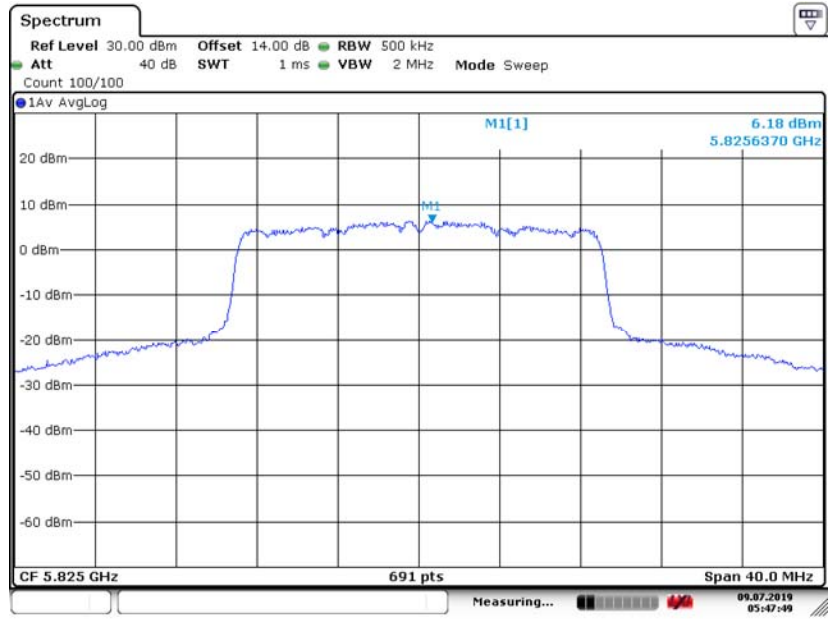

Date: 9.JUL.2019 05:47:49

Power Spectral Density	UNII Band I
Test Model 802.11n(HT40) mode	Frequency(MHz) 5190

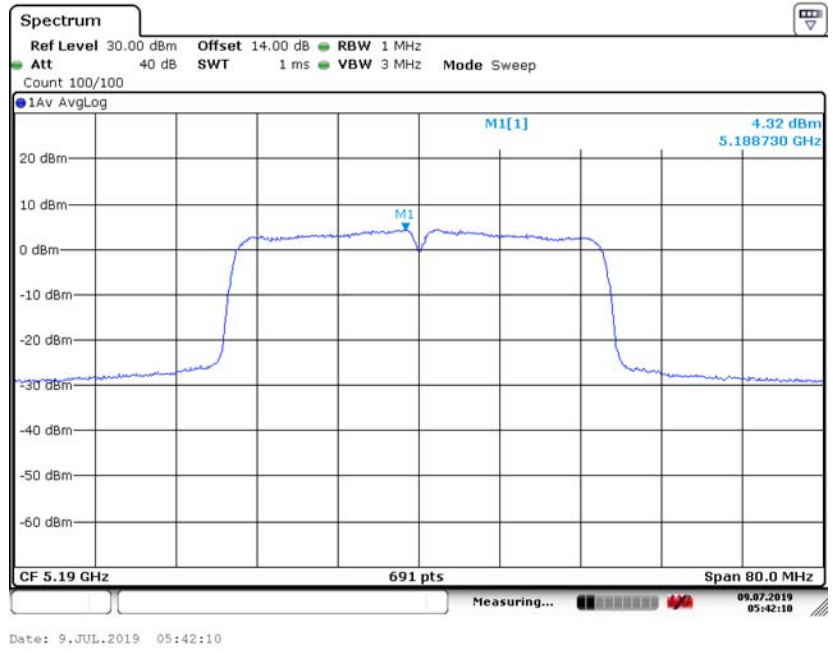

Power Spectral Density	UNII Band I
Test Model 802.11n(HT40) mode	Frequency(MHz) 5230

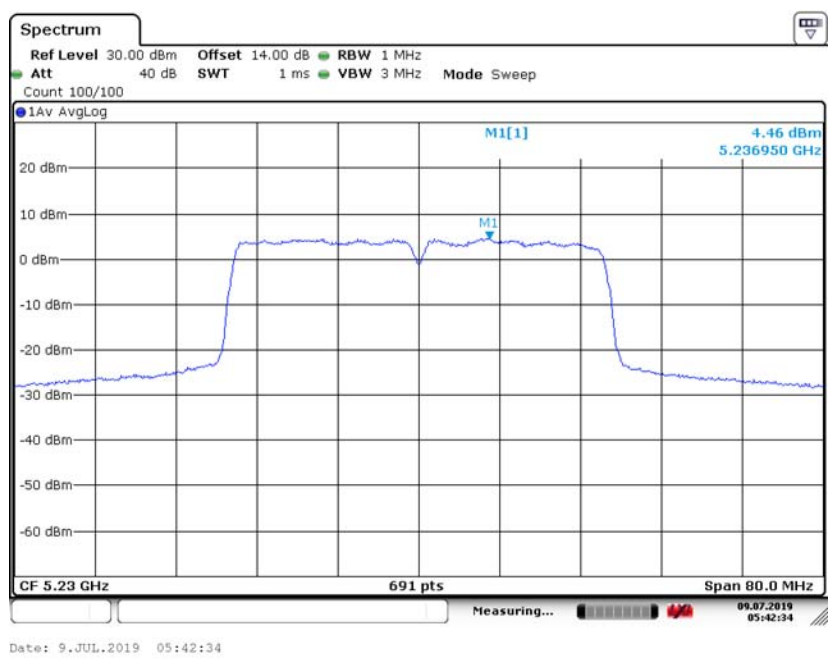

Power Spectral Density	UNII Band III
Test Model 802.11n(HT40) mode	Frequency(MHz) 5755

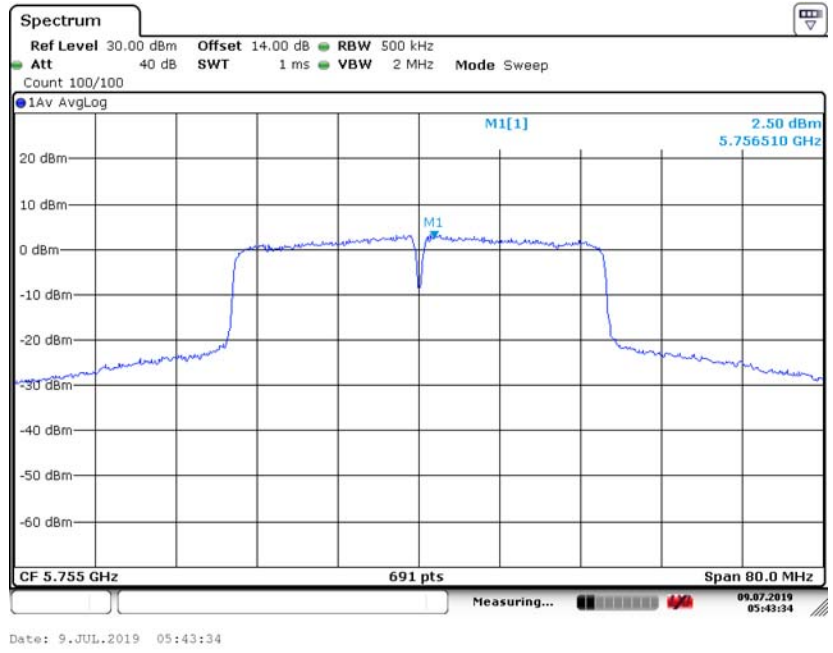

Power Spectral Density	UNII Band III
Test Model 802.11n(HT40) mode	Frequency(MHz) 5795

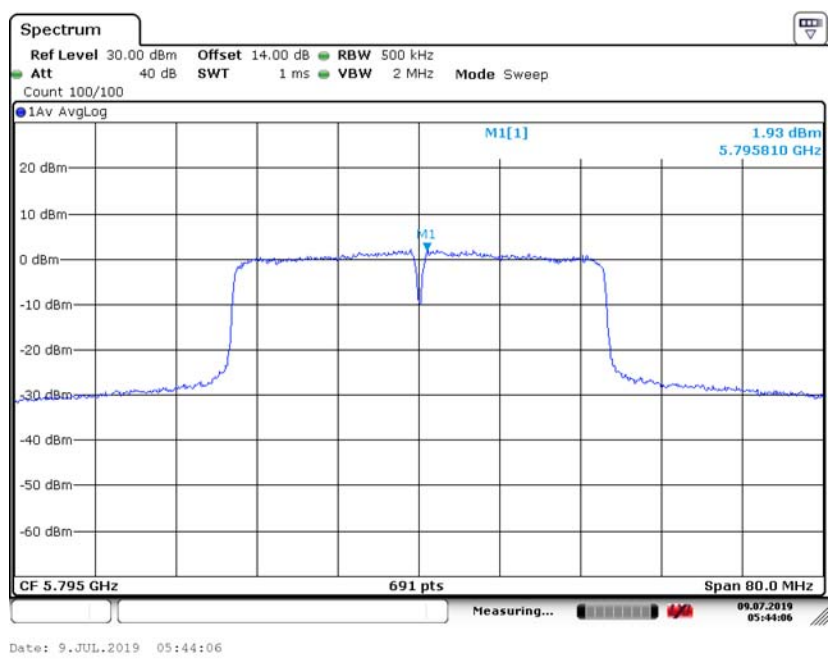



Power Spectral Density UNII Band I  
 Test Model 802.11ac(VHT40) mode Frequency(MHz) 5190

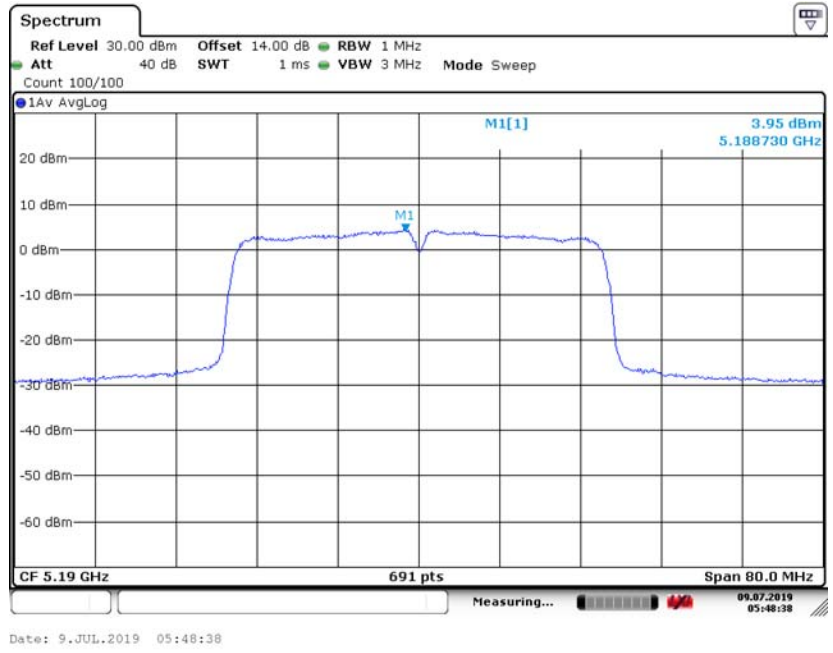

Power Spectral Density UNII Band I  
 Test Model 802.11ac(VHT40) mode Frequency(MHz) 5230

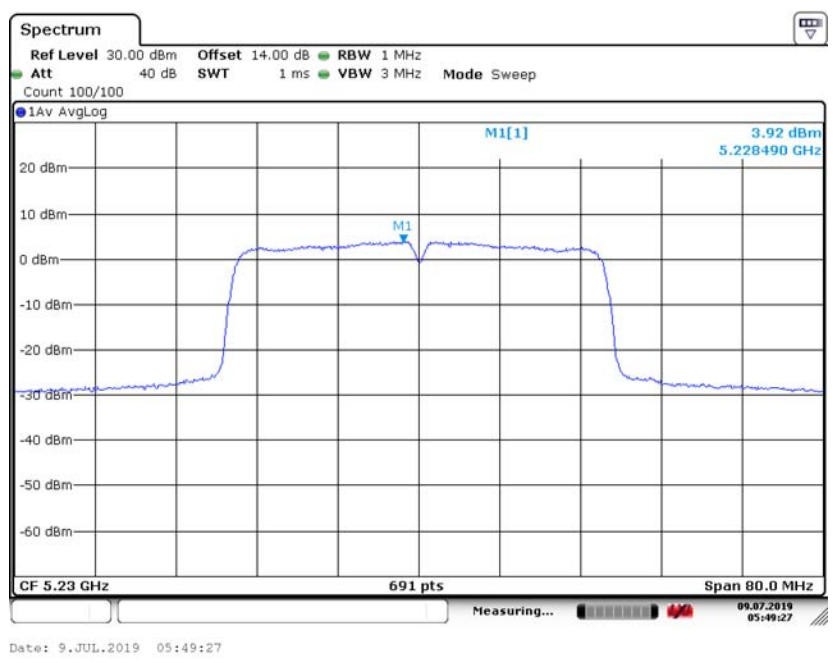

Power Spectral Density	UNII Band III
Test Model 802.11ac(VHT40) mode	Frequency(MHz) 5755

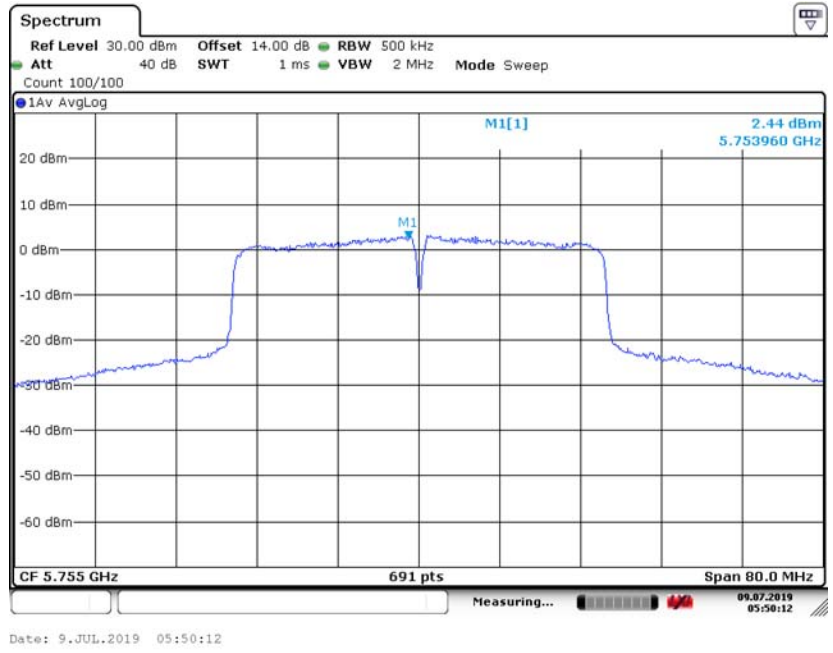

Power Spectral Density	UNII Band III
Test Model 802.11ac(VHT40) mode	Frequency(MHz) 5795

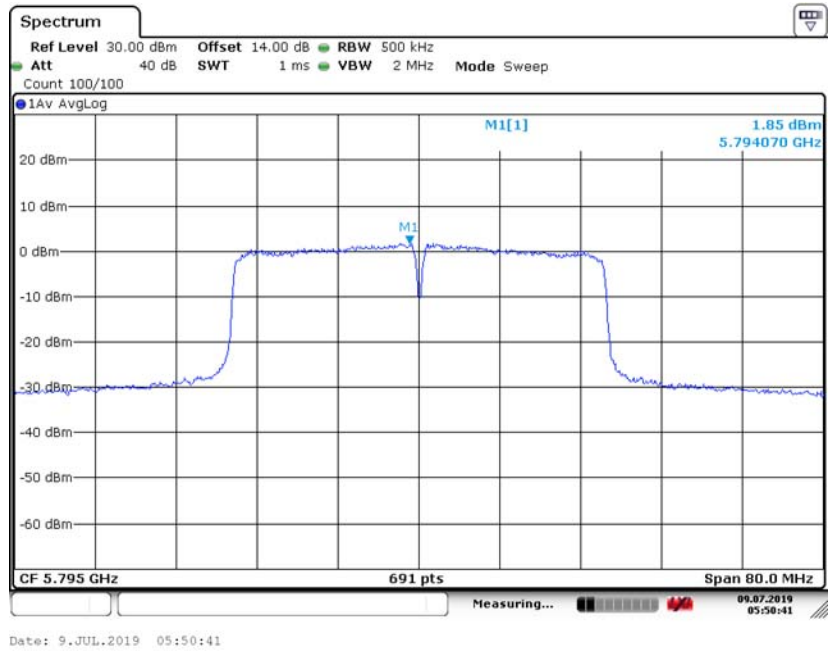

Power Spectral Density	UNII Band I
Test Model 802.11ac(VHT80) mode	Frequency(MHz) 5210

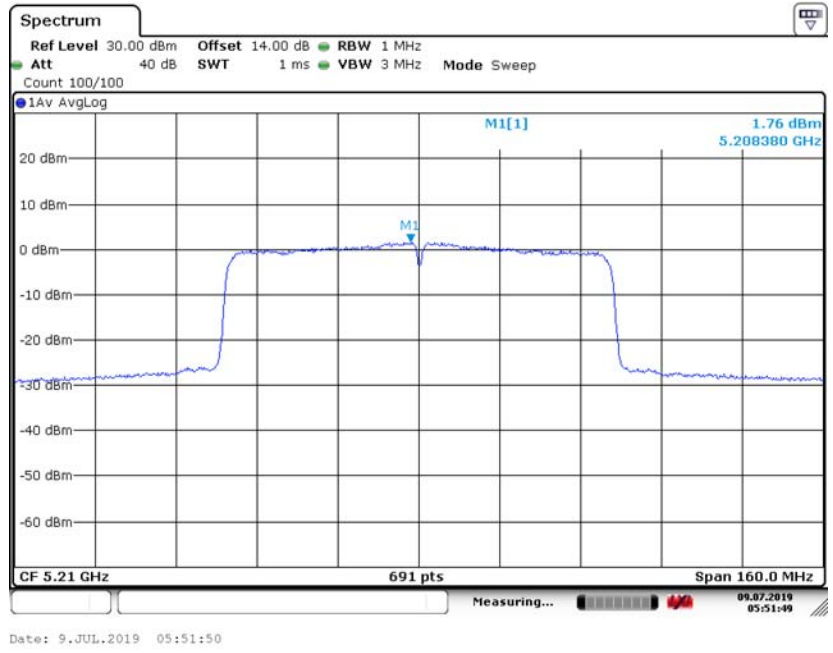

Power Spectral Density	UNII Band III
Test Model 802.11ac(VHT80) mode	Frequency(MHz) 5775

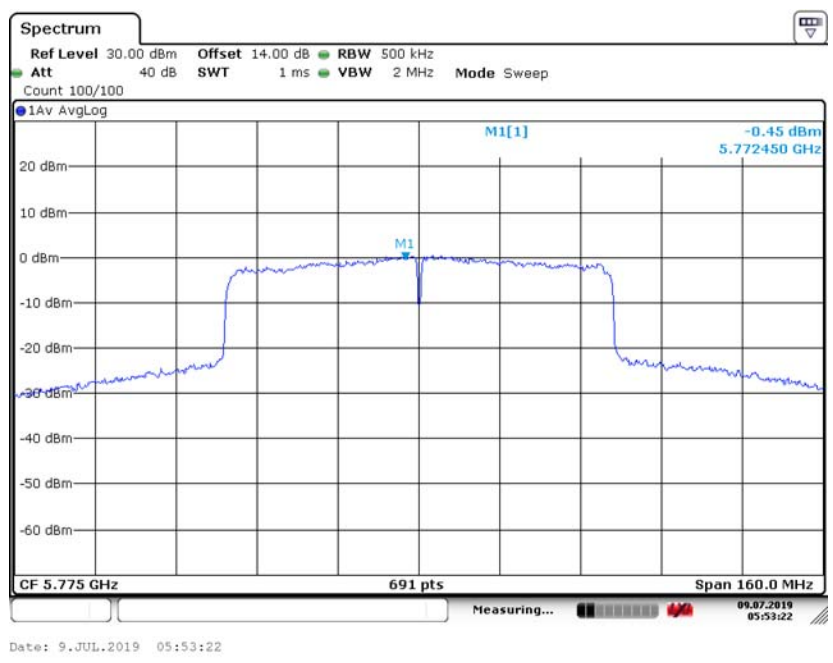

**B. Antenna 1**

Power Spectral Density	UNII Band I
Test Model 802.11a	Frequency(MHz) 5180

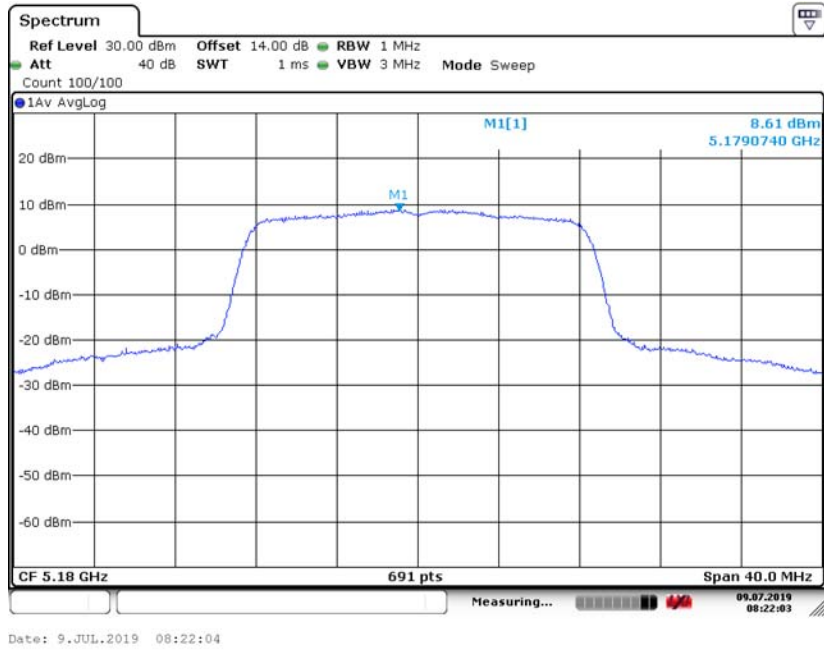

Power Spectral Density	UNII Band I
Test Model 802.11a	Frequency(MHz) 5200

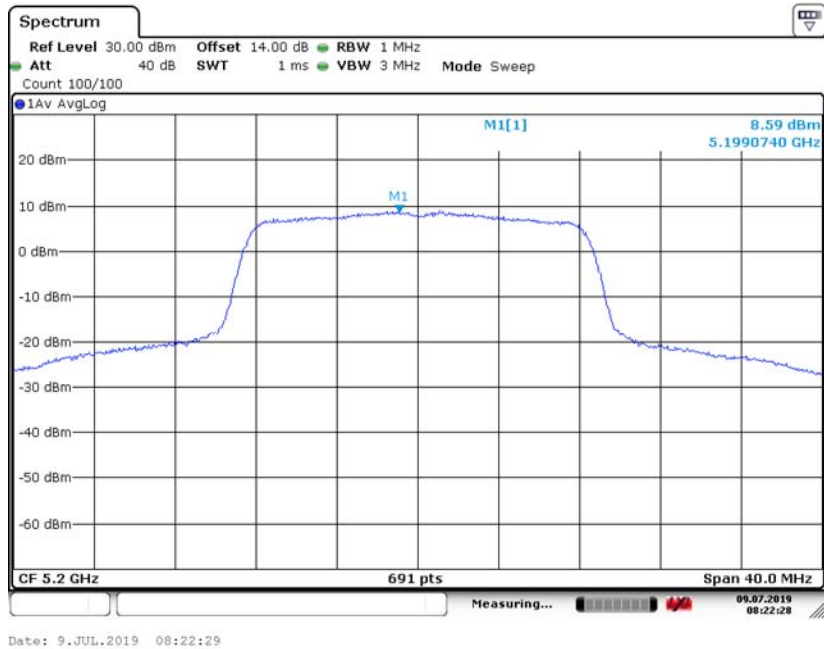

Power Spectral Density	UNII Band I
Test Model 802.11a	Frequency(MHz) 5240

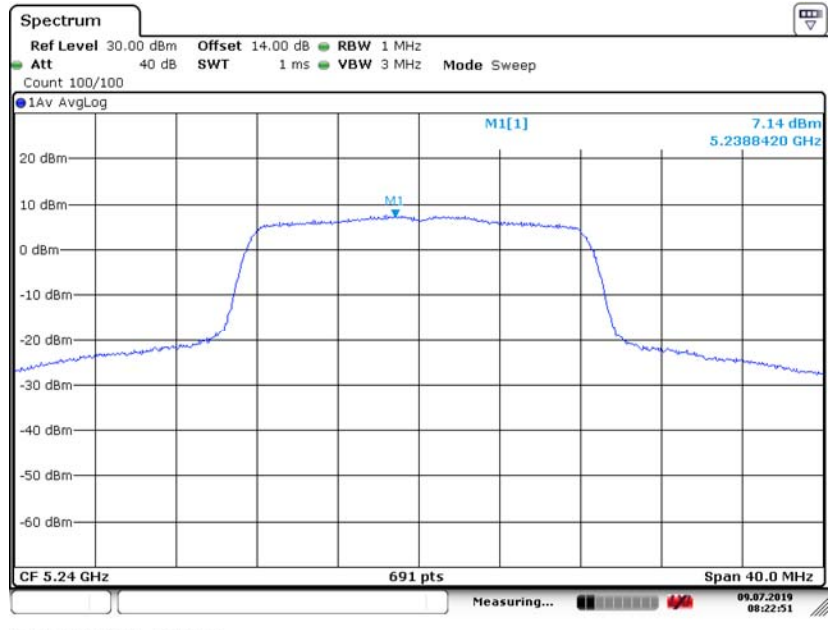

Date: 9.JUL.2019 08:22:51