

**ELECTROMAGNETIC EMISSIONS COMPLIANCE REPORT
INTENTIONAL RADIATOR CERTIFICATION TO
FCC CERTIFICATE REQUIREMENT**

OF

Thermal Receipt Printer

Model No.: DT-210, DT-230

FCC ID: Z7OTD2100

Trademark: 

Report No.: KAD141121076E

Issue Date: January 19, 2015

Prepared for

**Jiangmen Dascom Computer Peripherals Co., Ltd.
No.399, Jin Xing Road, Jiang Hai District, Jiangmen City, Guang Dong
Province, P.R. China**

Prepared by

**DONGGUAN EMTEK CO., LTD.
No.281, Guantai Road, Nancheng District,
Dongguan, Guangdong, China
TEL: 86-769-22807078
FAX: 86-769-22807079**

**This report shall not be reproduced, except in full, without the written approval of
DONGGUAN EMTEK CO., LTD.**

TABLE OF CONTENTS

Test Report Description	Page
1. DESCRIPTION OF STANDARDS AND RESULTS	5
2. GENERAL INFORMATION.....	6
2.1. Description of Device (EUT).....	6
2.2. Description of Support Device.....	7
2.3. Test Facility	7
2.4. Measurement Uncertainty	8
3. POWER LINE CONDUCTED MEASUREMENT	9
3.1. Test Equipment	9
3.2. Block Diagram of Test Setup	9
3.3. Configuration of EUT on Measurement.....	10
3.4. Operating Condition of EUT	10
3.5. Test Procedure.....	10
3.6. Power Line Conducted Emission Measurement Results	10
4. RADIATED EMISSION MEASUREMENT.....	13
4.1. Test Equipment	13
4.2. Block Diagram of Test Setup	14
4.3. Radiated Emission Limit (Class B).....	15
4.4. EUT Configuration on Measurement.....	15
4.5. Operating Condition of EUT	16
4.6. Test Procedure.....	16
4.7. Radiated Emission Measurement Result	16
5. PHOTOGRAPH.....	21
5.1. Photos of Conducted Emission Measurement	21
5.2. Photo of Radiated Measurement	22

APPENDIX (Photos of EUT) (4 Pages)

TEST REPORT DESCRIPTION

Applicant : Jiangmen Dascom Computer Peripherals Co., Ltd.
Manufacturer : Jiangmen Dascom Computer Peripherals Co., Ltd.
EUT : Thermal Receipt Printer
Model No. : DT-210, DT-230
Rating : For Adapter:
Input: AC 100-240V, 50/60Hz, 1.8A
Output: DC 24V, 3000mA, 72W

Measurement Procedure Used:

FCC Rules and Regulations Part 15 Subpart B Class B October 2014 & FCC / ANSI C63.4-2014

The device described above is tested by DONGGUAN EMTEK CO., LTD. to determine the maximum emission levels emanating from the device. The maximum emission levels are compared to the FCC Part 15 Subpart Class B limits both radiated and conducted emissions.

The measurement results are contained in this test report and DONGGUAN EMTEK CO., LTD. is assumed full responsibility for the accuracy and completeness of these measurements. Also, this report shows that the Equipment Under Test (EUT) is to be technically compliant with the FCC requirements.

This report applies to above tested sample only. This report shall not be reproduced in part without written approval of DONGGUAN EMTEK CO., LTD.

Date of Test : November 21, 2014 to January 08, 2015

Prepared by :



Ivy Huang/ Editor

Reviewer :



Hong Yang/ Supervisor

Approved & Authorized Signer :



Sam Lv / Manager



Modified Information

Version	Summary	Revision Date	Report No.
Ver.1.0	Original Report	/	KAD141121076E

1. DESCRIPTION OF STANDARDS AND RESULTS

EMISSION			
Description of Test Item	Standard	Limits	Results
Conducted Disturbance at Mains Terminals	FCC Part15, Subpart B, Class B ANSI C63.4-2014	§ 15.107(a)	Pass
Radiated Disturbance	FCC Part15, Subpart B, Class B ANSI C63.4-2014	§ 15.109(a)	Pass

2. GENERAL INFORMATION

2.1. Description of Device (EUT)

EUT	:	Thermal Receipt Printer
Model Number	:	DT-210, DT-230 (The two models are same except model number. Here DT-210 was prepared for full test.)
Trade Mark	:	
Power Supply for Test	:	AC 120V/60Hz for Adapter
Adapter	:	Model: TM-K072V-2403000PD Input: AC 100-240V, 50/60Hz, 1.8A Output: DC 24V, 3000mA, 72W
Operate Mode	:	Printing
Applicant	:	Jiangmen Dascom Computer Peripherals Co., Ltd.
Address	:	No.399, Jin Xing Road, Jiang Hai District, Jiangmen City, Guang Dong Province, P.R. China
Manufacturer	:	Jiangmen Dascom Computer Peripherals Co., Ltd.
Address	:	No.399, Jin Xing Road, Jiang Hai District, Jiangmen City, Guang Dong Province, P.R. China
Date of sample receiver	:	November 21, 2014
Date of Test	:	November 21, 2014 to January 08, 2015

2.2. Description of Support Device

PC	: Manufacturer: DELL M/N: OPTIRLEX 760 S/N: N/A CE, FCC: DOC
LCD Monitor	: Manufacturer: Sumsung M/N: B2230H Serial No.: YDG7HVGZ900053H FCC; CE
Mouse	: Manufacturer: DELL M/N: M-UAR DEL7 S/N: XN966 CE, FCC: DOC
Keyboard	: Manufacturer: DELL M/N: L30U S/N: ON277F CE, FCC: DOC

2.3. Test Facility

Site Description
EMC Lab.

: Accredited by CNAS, 2012.07.04
The certificate is valid until 2015.07.03
The Laboratory has been assessed and proved to be in compliance with CNAS/CL01: 2006
The Certificate Registration Number is L3150

Accredited by TUV Rheinland, 2014.05.22
The certificate is valid until 2015.11.21
The Laboratory has been assessed according to the requirements ISO/IEC 17025: 2005

Accredited by FCC, June 18, 2014
The Certificate Number is 247565

Accredited by Industry Canada, February 19, 2014
The Certificate Number is 9444A.

Name of Firm : DONGGUAN EMTEK CO., LTD.
Site Location : No.281, Guantai Road, Nancheng District, Dongguan, Guangdong, China

2.4. Measurement Uncertainty

Test Item	Uncertainty
Conducted Emission Uncertainty	: 2.42dB
Disturbance Power	: 2.86dB
Radiated Emission Uncertainty (3m Chamber)	: 3.34dB (30M~1GHz Polarize: H) 3.32dB (30M~1GHz Polarize: V)
Uncertainty for test site temperature and humidity	: 0.6°C 4%

3. POWER LINE CONDUCTED MEASUREMENT

3.1. Test Equipment

The following test equipments are used during the power line conducted measurement:

Item	Equipment	Manufacturer	Model No.	Serial No.	Last Cal.	Cal. Interval
1.	Test Receiver	Rohde & Schwarz	ESCS30	100018	May 16, 2014	1 Year
2.	L.I.S.N	Rohde & Schwarz	ENV216	100017	May 16, 2014	1 Year
3.	RF switching Unit	CDS	RUS-M2	38401	May 16, 2014	1 Year

3.2. Block Diagram of Test Setup

3.2.1. Block diagram of connection between the EUT and simulators

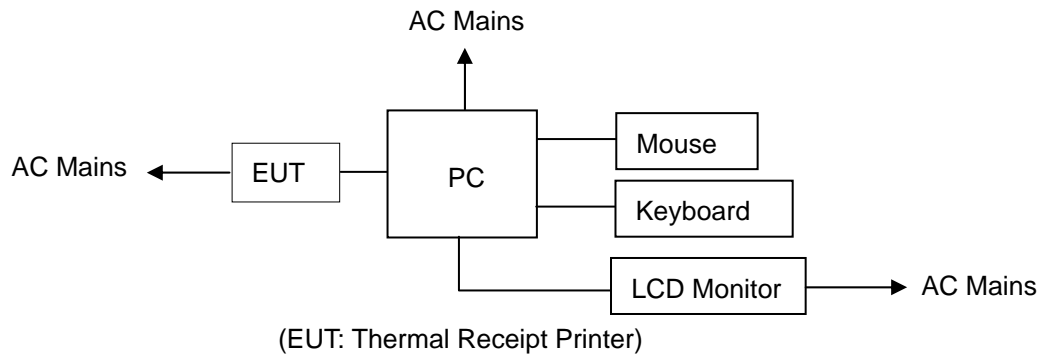

3.2.2. Block diagram of test setup

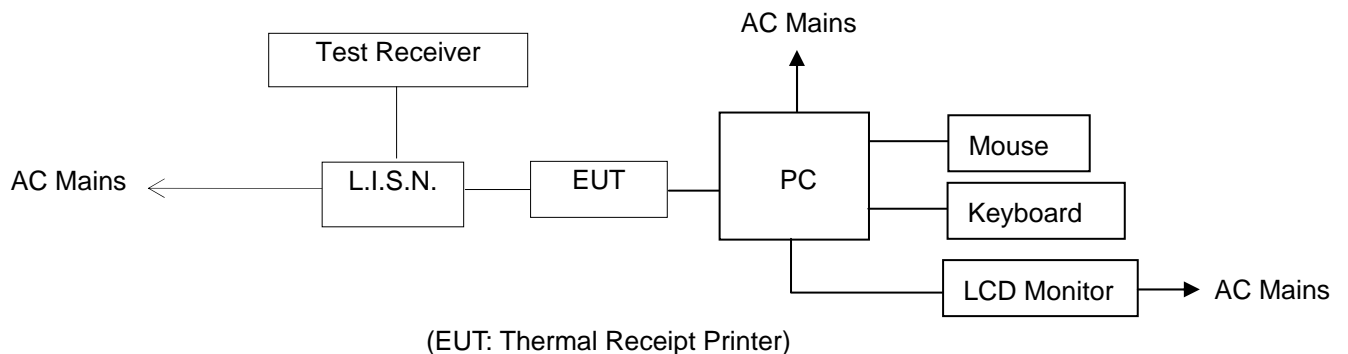

3.2.3. Power Line Conducted Emission Measurement Limits (Class B)

Frequency MHz	Limits dB(μV)	
	Quasi-peak Level	Average Level
0.15 ~ 0.50	66.0 ~ 56.0*	56.0 ~ 46.0*
0.50 ~ 5.00	56.0	46.0
5.00 ~ 30.00	60.0	50.0
NOTE1-The lower limit shall apply at the transition frequencies. NOTE2-The limit decreases linearly with the logarithm of the frequency in the range 0.15MHz to 0.50MHz.		

3.3. Configuration of EUT on Measurement

The following equipments are installed on Power Line Conducted Emission Measurement to meet the commission requirement and operating regulations in a manner which tends to maximize its emission characteristics in a normal application.

EUT : Thermal Receipt Printer
 Model Number : DT-210

3.4. Operating Condition of EUT

- 3.4.1. Setup the EUT and simulator as shown as Section 3.2.
- 3.4.2. Turn on the power of all equipment.
- 3.4.3. Let the EUT work in test mode (Printing) and measure it.

3.5. Test Procedure

The EUT system is connected to the power mains through a line impedance stabilization network (L.I.S.N.). This provides a 50ohm coupling impedance for the EUT system. Please refer the block diagram of the test setup and photographs. Both sides of AC line are checked to find out the maximum conducted emission. In order to find the maximum emission levels, the relative positions of equipment and all of the interface cables shall be changed according to FCC ANSI C63.4-2014 on Conducted Emission Measurement.

The bandwidth of test receiver (R&S ESCS30) is set at 9KHz.

The frequency range from 150kHz to 30MHz is investigated.
 The scanning waveforms are below the following pages.

3.6. Power Line Conducted Emission Measurement Results

PASS

Please see the attached pages.

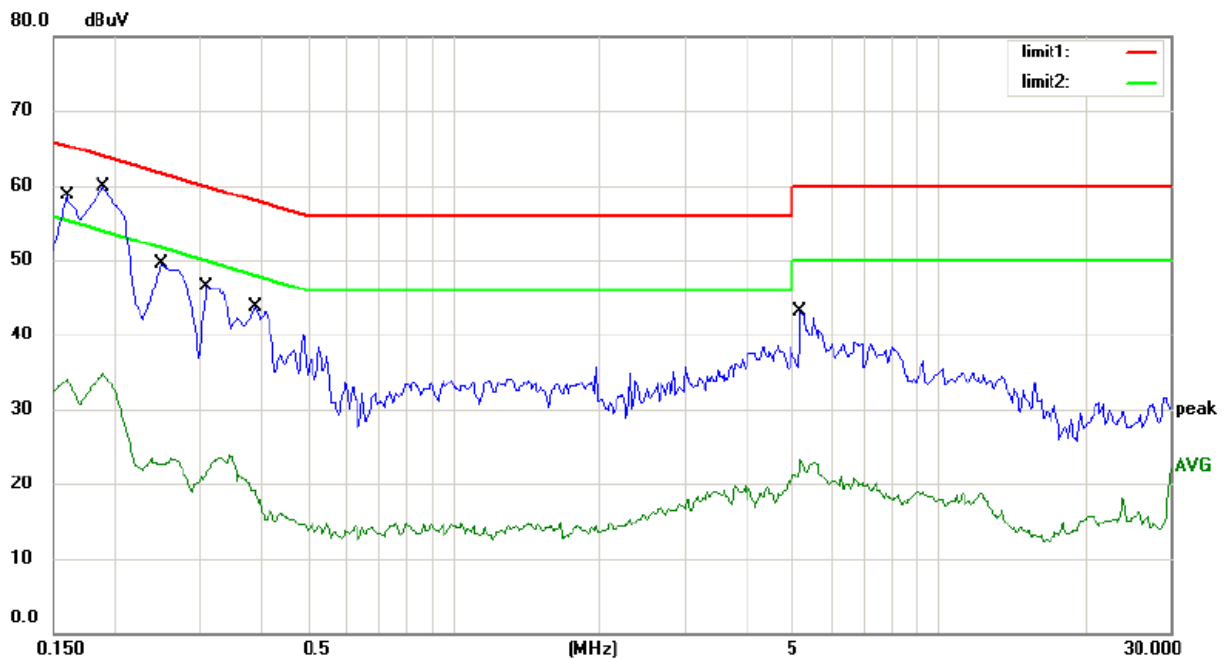

Site Chamber #1

Phase: L1

Temperature 24

Limit: (CE)FCC PART 15 class B_QP

Power: AC 120V/60Hz

Humidity: 55 %

Mode: Printing

Note: USB interface connection

No.	Mk.	Freq. MHz	Reading Level dBuV	Correct Factor dB	Measure- ment dBuV	Limit dBuV	Over dB	Detector	Comment
1		0.1600	55.62	0.00	55.62	65.46	-9.84	QP	
2		0.1600	34.11	0.00	34.11	55.46	-21.35	AVG	
3	*	0.1900	56.84	0.00	56.84	64.04	-7.20	QP	
4		0.1900	34.83	0.00	34.83	54.04	-19.21	AVG	
5		0.2500	49.41	0.00	49.41	61.76	-12.35	QP	
6		0.2500	23.43	0.00	23.43	51.76	-28.33	AVG	
7		0.3100	46.48	0.00	46.48	59.97	-13.49	QP	
8		0.3100	23.32	0.00	23.32	49.97	-26.65	AVG	
9		0.3900	43.76	0.00	43.76	58.06	-14.30	QP	
10		0.3900	20.30	0.00	20.30	48.06	-27.76	AVG	
11		5.2000	43.06	0.00	43.06	60.00	-16.94	QP	
12		5.2000	23.32	0.00	23.32	50.00	-26.68	AVG	

*:Maximum data x:Over limit !:over margin Comment: Factor build in receiver. Operator: QIU

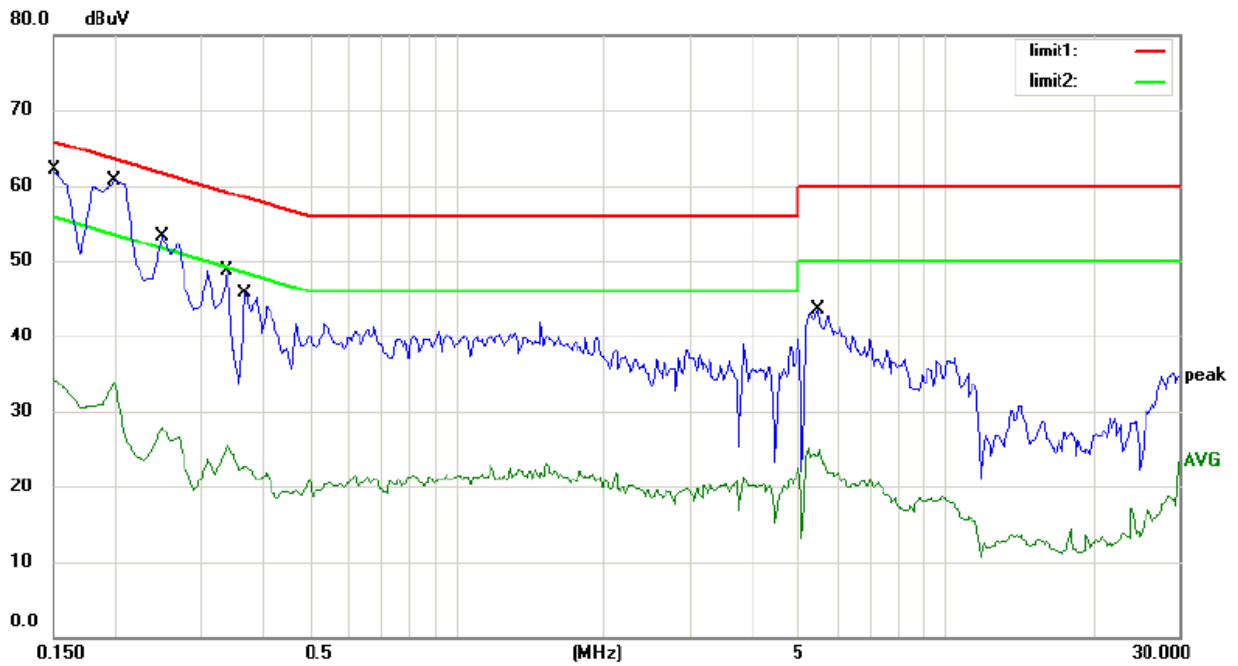

Site Chamber #1

Phase: **N**

Temperature 24

Limit: (CE)FCC PART 15 class B_QP

Power: AC 120V/60Hz

Humidity: 55 %

Mode: Printing

Note: USB interface connection

No.	Mk.	Freq.	Reading Level	Correct Factor	Measurement	Limit	Over	Detector	Comment
		MHz	dBuV	dB	dBuV	dBuV	dB		
1		0.1500	58.11	0.00	58.11	66.00	-7.89	QP	
2		0.1500	34.44	0.00	34.44	56.00	-21.56	AVG	
3	*	0.2000	57.63	0.00	57.63	63.61	-5.98	QP	
4		0.2000	33.92	0.00	33.92	53.61	-19.69	AVG	
5		0.2500	53.32	0.00	53.32	61.76	-8.44	QP	
6		0.2500	27.95	0.00	27.95	51.76	-23.81	AVG	
7		0.3400	48.71	0.00	48.71	59.20	-10.49	QP	
8		0.3400	25.49	0.00	25.49	49.20	-23.71	AVG	
9		0.3700	45.74	0.00	45.74	58.50	-12.76	QP	
10		0.3700	22.74	0.00	22.74	48.50	-25.76	AVG	
11		5.4800	43.56	0.00	43.56	60.00	-16.44	QP	
12		5.4800	24.80	0.00	24.80	50.00	-25.20	AVG	

*:Maximum data x:Over limit !:over margin Comment: Factor build in receiver. Operator: QIU

4. RADIATED EMISSION MEASUREMENT

4.1. Test Equipment

The following test equipments are used during the radiated emission measurement:

4.1.1. For Anechoic Chamber

Item	Equipment	Manufacturer	Model No.	Serial No.	Last Cal.	Cal. Interval
1.	Test Receiver	Rohde & Schwarz	ESCI	1166.5950.03	May 16, 2014	1 Year
2.	Bilog Antenna	Schwarzbeck	VULB9163	000141	May 16, 2014	1 Year
3.	Power Amplifier	CDS	RSU-M352	818	May 16, 2014	1 Year
4.	Power Amplifier	HP	8447F	OPT H64	May 16, 2014	1 Year
5.	Color Monitor	SUNSP0	SP-140A	N/A	May 16, 2014	1 Year
6.	Single Line Filter	JIANLI	XL-3	N/A	May 16, 2014	1 Year
7.	Single Phase Power Line Filter	JIANLI	DL-2X100B	N/A	May 16, 2014	1 Year
8.	3 Phase Power Line Filter	JIANLI	DL-4X100B	N/A	May 16, 2014	1 Year
9.	DC Power Filter	JIANLI	DL-2X50B	N/A	May 16, 2014	1 Year
10.	Cable	Schwarzbeck	PLF-100	519489	May 19, 2014	1 Year
11.	Cable	Rosenberger	CIL02	A0783566	May 19, 2014	1 Year
12.	Cable	Rosenberger	RG 233/U	525178	May 19, 2014	1 Year

4.2. Block Diagram of Test Setup

4.2.1. Block diagram of connection between the EUT and simulators

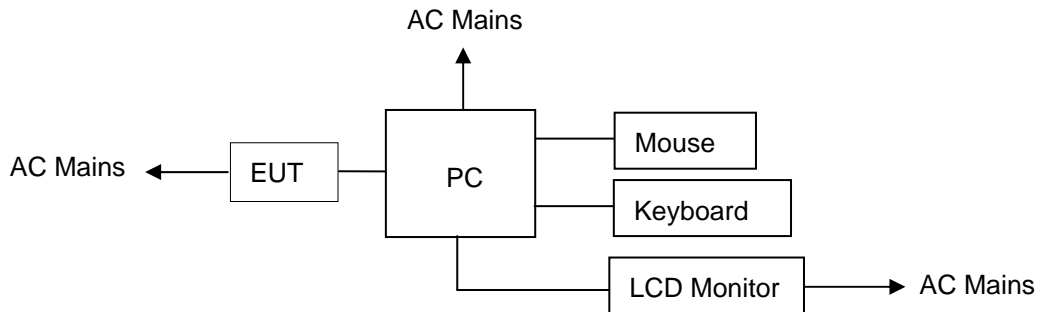

(EUT: Thermal Receipt Printer)

4.2.2. Anechoic Chamber Test Setup Diagram

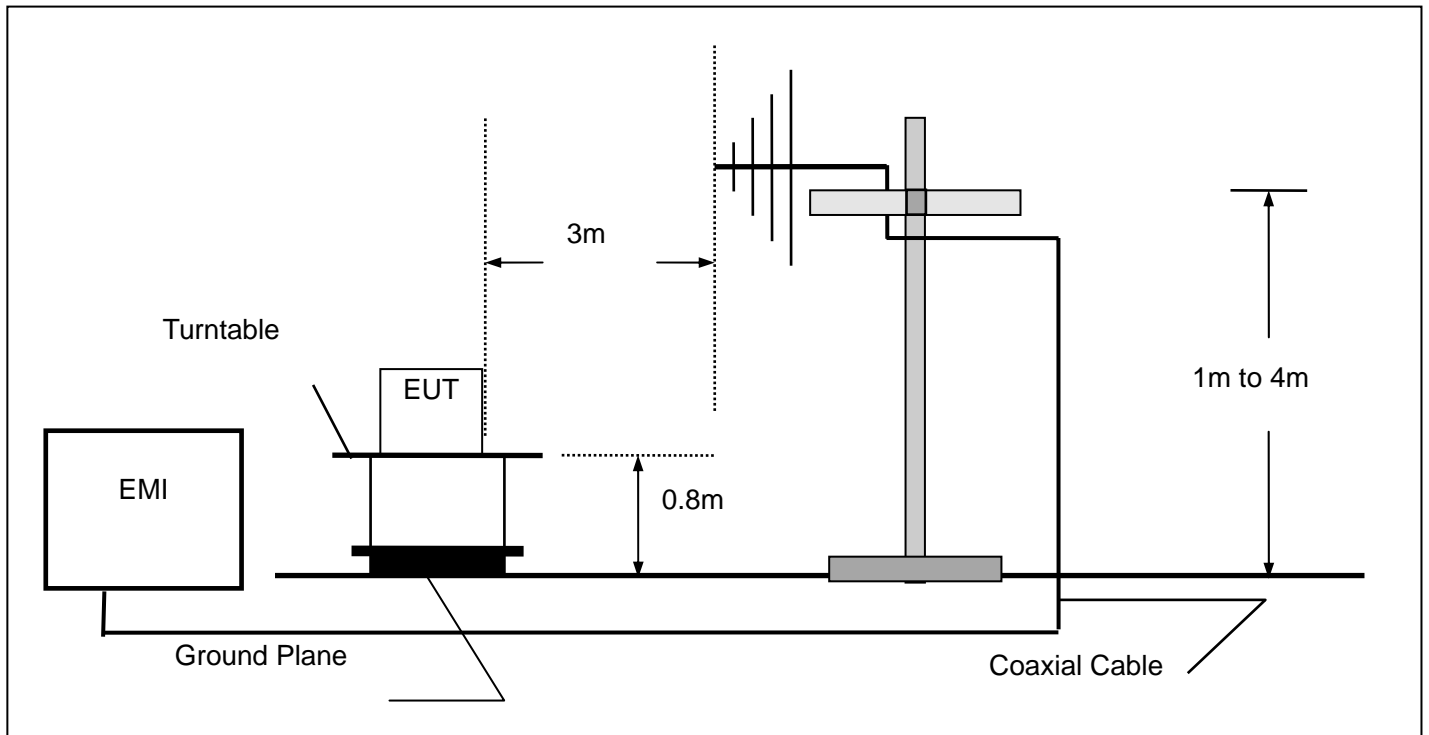

(EUT: Thermal Receipt Printer)

4.3. Radiated Emission Limit (Class B)

Limits below 1GHz

FREQUENCY MHz	DISTANCE Meters	FIELD STRENGTHS LIMIT	
		$\mu\text{V}/\text{m}$	$\text{dB}(\mu\text{V})/\text{m}$
30 ~ 88	3	100	40.0
88 ~ 216	3	150	43.5
216 ~ 960	3	200	46.0
960 ~ 1000	3	500	54.0

Limits above 1GHz

Frequency (GHz)	Distance (Meters)	Field Strengths Limit	
		Average ($\text{dB}\mu\text{V}/\text{m}$)	Peak ($\text{dB}\mu\text{V}/\text{m}$)
1~15	3	54	74

Highest frequency generated or used in the device (MHz)	Upper frequency of Radiated measurement (MHz)
Below 1.705	No radiated testing required
1.705~108	1000
108~500	2000
500~1000	5000
Above 1000	5th harmonic of the highest frequency or 40GHz, whichever is lower

- Remark:
- (1) Emission level $(\text{dB})\mu\text{V} = 20 \log$ Emission level $\mu\text{V}/\text{m}$
 - (2) The smaller limit shall apply at the cross point between two frequency bands.
 - (3) Distance is the distance in meters between the measuring instrument, antenna and the closest point of any part of the device or system.

4.4. EUT Configuration on Measurement

The following equipment are installed on Radiated Emission Measurement to meet the commission requirements and operating regulations in a manner which tends to maximize its emission characteristics in normal application.

EUT : Thermal Receipt Printer
 Model Number : DT-210

4.5. Operating Condition of EUT

- 4.5.1. Setup the EUT as shown in Section 4.2.
- 4.5.2. Turn on the power of all equipment.
- 4.5.3. Let the EUT work in test mode (ON) and measure it.

4.6. Test Procedure

EUT and its simulators are placed on a turntable, which is 0.8 meter high above ground. The turntable can rotate 360 degrees to determine the position of the maximum emission level. EUT is set 3.0 meters away from the receiving antenna, which is mounted on an antenna tower. The antenna can be moved up and down between 1 meter and 4 meters to find out the maximum emission level. Broadband antenna (calibrated bilog antenna) is used as receiving antenna. Both horizontal and vertical polarization of the antenna is set on measurement. In order to find the maximum emission levels, all of the interface cables must be manipulated according to ANSI C63.4-2014 on radiated emission measurement.

The bandwidth of the EMI test receiver (R&S ESCI) is set at 120KHz.

The scanning curves in below a few pages.

4.7. Radiated Emission Measurement Result

PASS.

The frequency range from 30MHz to 2000MHz is investigated.

Please see the attached pages.

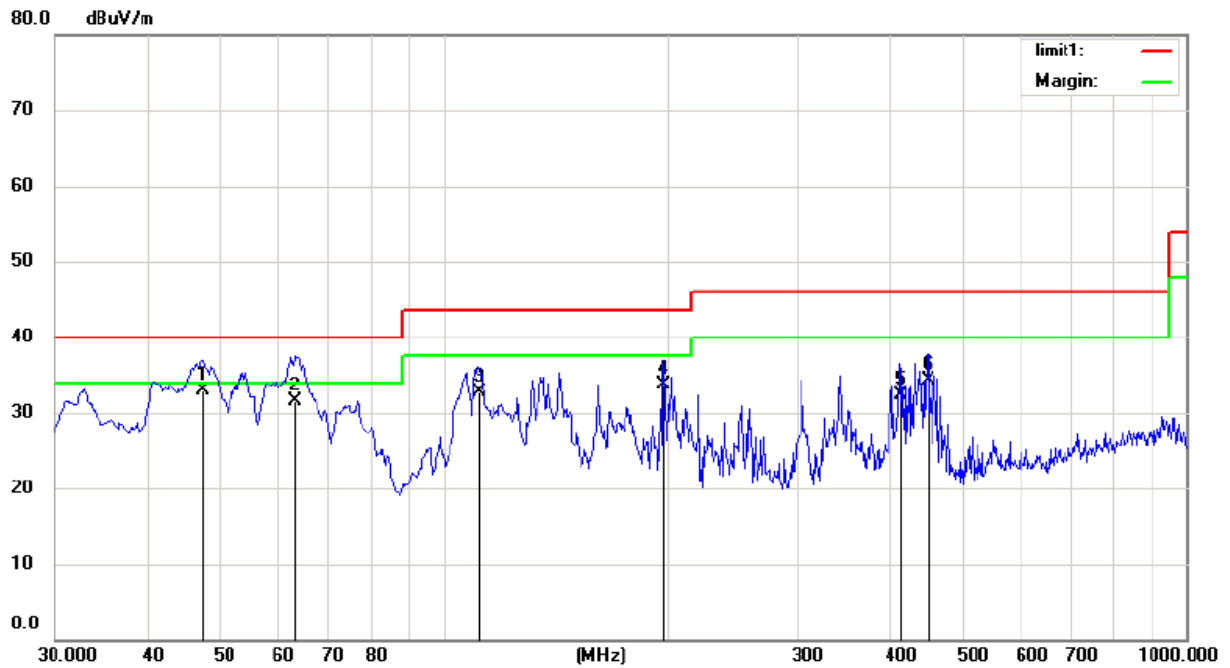

Site Chamber #1 Polarization: **Horizontal** Temperature: 26
 Limit: (RE)FCC PART 15 class B 3m Power: AC 120V/60Hz Humidity: 55 %
 Mode: Printing
 Note: USB interface connection

No.	Mk.	Freq. MHz	Reading Level dBuV	Correct Factor dB	Measure- ment dBuV/m	Limit dBuV/m	Over dB	Antenna Height cm	Table Degree degree	Comment
1	*	47.4600	47.30	-14.38	32.92	40.00	-7.08	QP		
2		63.3132	51.90	-20.36	31.54	40.00	-8.46	QP		
3		111.4800	50.20	-17.48	32.72	43.50	-10.78	QP		
4		197.8100	51.40	-17.78	33.62	43.50	-9.88	QP		
5		413.1500	43.60	-11.36	32.24	46.00	-13.76	QP		
6		449.0400	45.50	-11.23	34.27	46.00	-11.73	QP		

*:Maximum data x:Over limit !:over margin

Operator: QIU

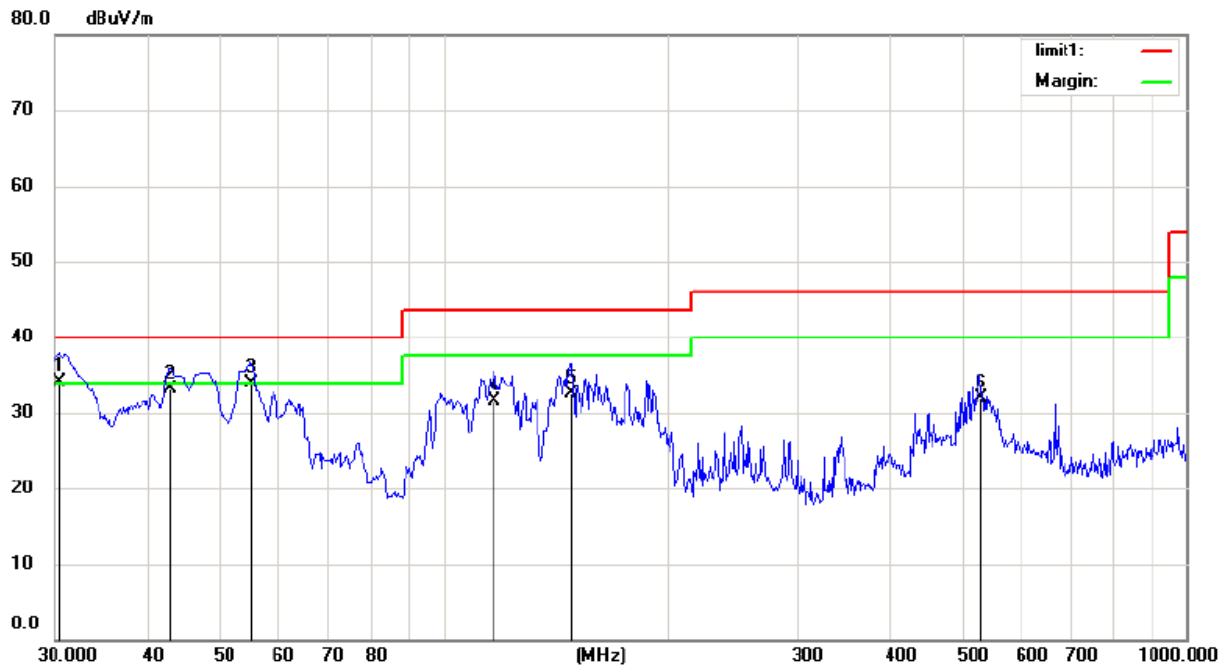

Site Chamber #1

Polarization: **Vertical**

Temperature: 26

Limit: (RE)FCC PART 15 class B 3m

Power: AC 120V/60Hz

Humidity: 55 %

Mode: Printing

Note: USB interface connection

No.	Mk.	Freq. MHz	Reading Level dBuV	Correct Factor dB	Measure- ment dBuV/m	Limit dBuV/m	Over dB	Antenna Height cm	Table Degree degree	Detector	Comment
1	*	30.4237	49.10	-15.03	34.07	40.00	-5.93			QP	
2		42.8997	46.50	-13.45	33.05	40.00	-6.95			QP	
3		55.2200	51.30	-17.46	33.84	40.00	-6.16			QP	
4		117.3000	48.70	-17.14	31.56	43.50	-11.94			QP	
5		148.3400	50.20	-17.63	32.57	43.50	-10.93			QP	
6		528.5800	41.70	-9.83	31.87	46.00	-14.13			QP	

*:Maximum data x:Over limit !:over margin

Operator: QIU

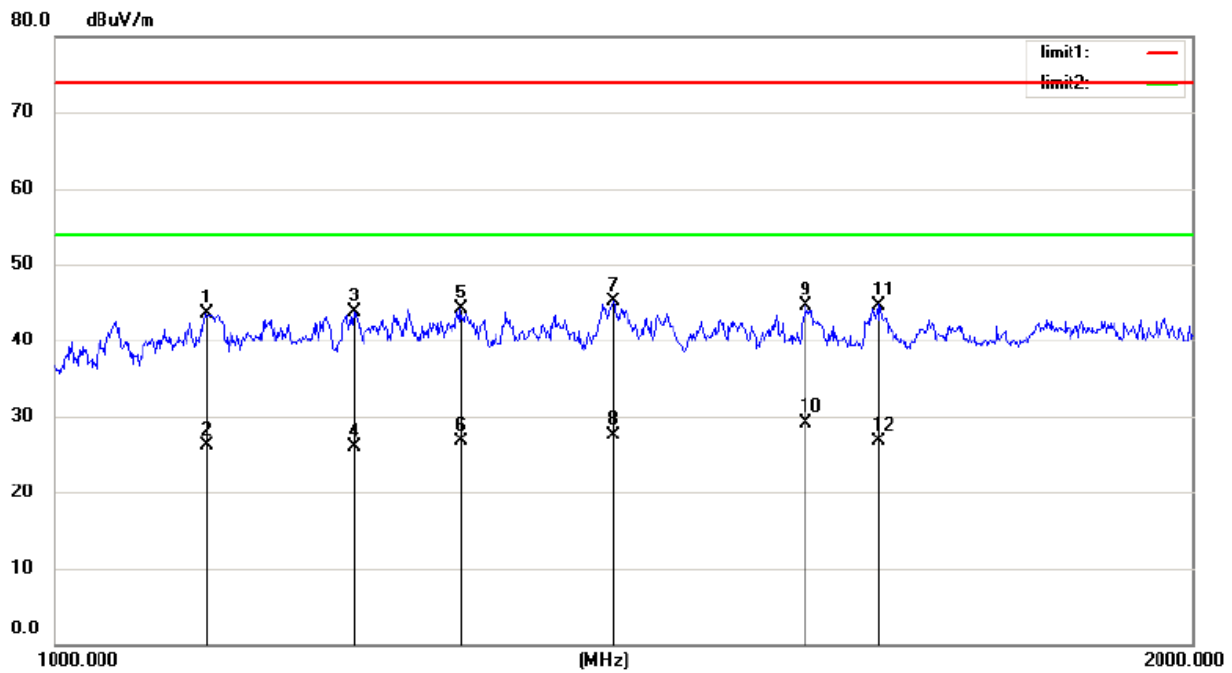

Site Chamber #1 Polarization: **Horizontal** Temperature: 26
 Limit: (RE)FCC PART 15 class B 3m_PEAK Power: AC 120V/60Hz Humidity: 55 %
 Mode: Printing
 Note: USB interface connection

No.	Mk.	Freq.	Reading Level	Correct Factor	Measurement	Limit	Over	Antenna Height	Table Degree	
		MHz	dBuV	dB	dBuV/m	dBuV/m	dB	cm	degree	Comment
1		1096.572	57.05	-13.49	43.56	74.00	-30.44			peak
2		1096.572	39.50	-13.49	26.01	54.00	-27.99			AVG
3		1199.971	55.44	-11.71	43.73	74.00	-30.27			peak
4		1199.971	37.60	-11.71	25.89	54.00	-28.11			AVG
5		1280.760	55.88	-11.69	44.19	74.00	-29.81			peak
6		1280.760	38.30	-11.69	26.61	54.00	-27.39			AVG
7		1405.418	56.67	-11.66	45.01	74.00	-28.99			peak
8		1405.418	39.20	-11.66	27.54	54.00	-26.46			AVG
9		1581.178	56.02	-11.54	44.48	74.00	-29.52			peak
10	*	1581.178	40.60	-11.54	29.06	54.00	-24.94			AVG
11		1651.755	56.53	-11.93	44.60	74.00	-29.40			peak
12		1651.755	38.70	-11.93	26.77	54.00	-27.23			AVG

*:Maximum data x:Over limit !:over margin

Operator: QIU

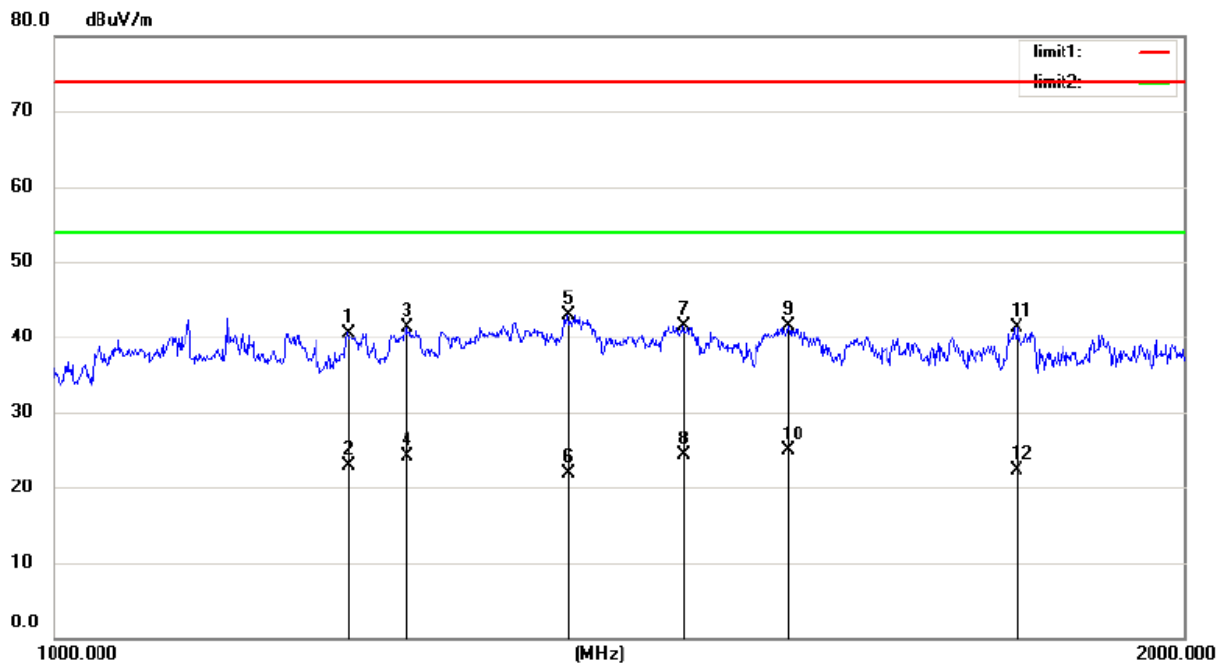

Site Chamber #1 Polarization: **Vertical** Temperature: 26
 Limit: (RE)FCC PART 15 class B 3m_PEAK Power: AC 120V/60Hz Humidity: 55 %
 Mode:Printing
 Note: USB interface connection

No.	Mk.	Freq.	Reading Level	Correct Factor	Measurement	Limit	Over	Antenna Height	Table Degree	
		MHz	dBuV	dB	dBuV/m	dBuV/m	dB	cm	degree	Comment
1		1196.649	56.30	-15.70	40.60	74.00	-33.40			peak
2		1196.649	38.70	-15.70	23.00	54.00	-31.00			AVG
3		1241.427	57.07	-15.71	41.36	74.00	-32.64			peak
4		1241.427	39.90	-15.71	24.19	54.00	-29.81			AVG
5		1369.833	58.49	-15.67	42.82	74.00	-31.18			peak
6		1369.833	37.60	-15.67	21.93	54.00	-32.07			AVG
7		1471.207	57.47	-15.96	41.51	74.00	-32.49			peak
8		1471.207	40.30	-15.96	24.34	54.00	-29.66			AVG
9		1569.168	57.82	-16.39	41.43	74.00	-32.57			peak
10	*	1569.168	41.20	-16.39	24.81	54.00	-29.19			AVG
11		1806.253	58.35	-17.09	41.26	74.00	-32.74			peak
12		1806.253	39.40	-17.09	22.31	54.00	-31.69			AVG

*:Maximum data x:Over limit !:over margin

Operator: QIU

5. PHOTOGRAPH

5.1. Photos of Conducted Emission Measurement



5.2. Photo of Radiated Measurement

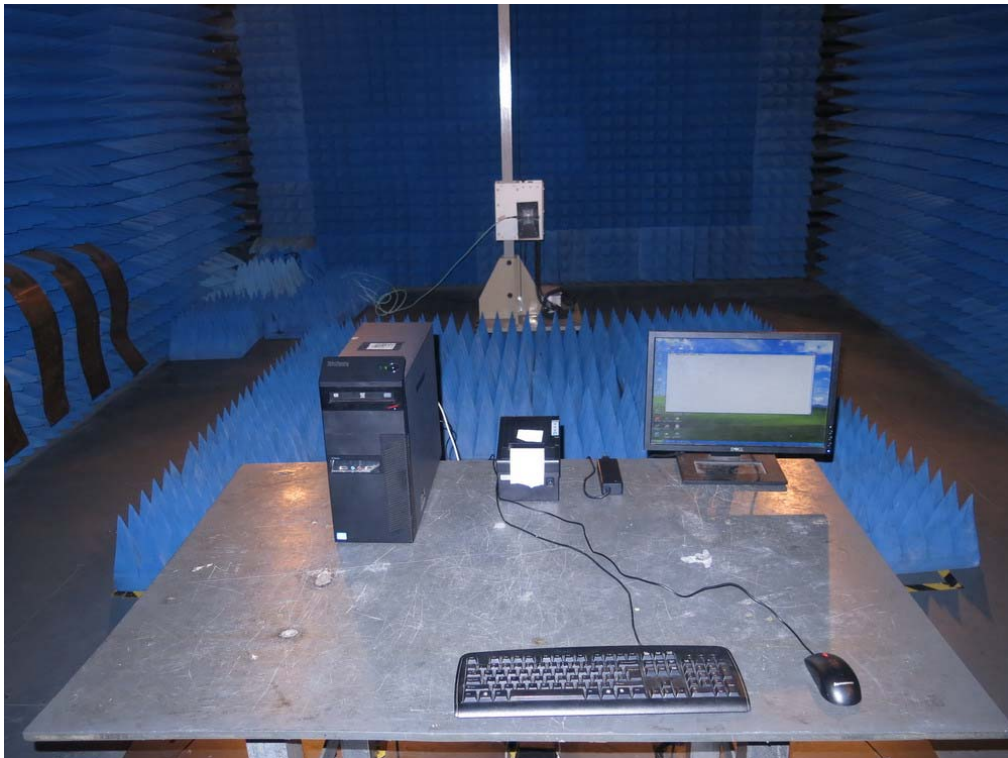

APPENDIX (Photos of EUT)



