



Shenzhen BCTC Technology Co., Ltd.

Report No.: BCTC21070347E

FCC ID TEST REPORT

for

Bluetooth Helmet Headset

MODEL:

**V5, V1, cool Rider, Easy Rider, 1098, V6, V8, V9, V10, v20,
v30, v50, v60, v80, v90**

FCC ID: Z6T-V5

Test Report Number: BCTC21070347E

Issued Date: October 24, 2011

Issued for

ITALY VIMOTO TECHNOLOGY(HK)LIMITED

**Room 1708A1, Nanfei Building NO.173 Des Voeux Road
Central, Hong Kong**

Issued By:

Shenzhen BCTC Technology Co., Ltd.

**B Building Room8518, Multiple Use Building of Economic Cooperative,
Team one, Anle country, No. 44 of Xin'an Block, Bao'an Area, Shenzhen**

TEL: +86-755- 33865088

FAX: +86-755- 36933236

Note: This report shall not be reproduced except in full, without the written approval of Shenzhen BCTC Technology Co., Ltd. This document may be altered or revised by Shenzhen BCTC Technology Co., Ltd. personnel only, and shall be noted in the revision section of the document. The test results in the report only apply to the tested sample.



Shenzhen BCTC Technology Co., Ltd.

Report No.: BCTC21070347E

Revision History Of Report

Rev.	Issue No.	Revisions	Effect Page	Revised By
00	BCTC21070347E	Initial Issue	ALL	Lisa Zhu



TABLE OF CONTENTS

1	TEST CERTIFICATION	4
2	TEST RESULT SUMMARY	5
3	EUT DESCRIPTION	6
4	TEST METHODOLOGY	7
	4.1. DECISION OF FINAL TEST MODE.....	7
	4.2. EUT SYSTEM OPERATION	7
5	SETUP OF EQUIPMENT UNDER TEST	8
	5.1. DESCRIPTION OF SUPPORT UNITS	8
	5.2. CONFIGURATION OF SYSTEM UNDER TEST	8
6	FACILITIES AND ACCREDITATIONS	9
6.2	MEASUREMENT UNCERTAINTY	9
7	TEST REQUIREMENTS	9
	7.1. CONDUCTED EMISSION MEASUREMENT.....	9
	7.2. Radiation Emission Test	14
	7.3. Band edge test.....	20
	8. Antenna requirement.....	25



1 TEST CERTIFICATION

Product:	Bluetooth Helmet Headset
Model:	V5, V1, cool Rider, Easy Rider, 1098, V6, V8, V9, V10, v20, v30, v50, v60, v80, v90
Applicant:	ITALY VIMOTO TECHNOLOGY(HK)LIMITED Room 1708A1, Nanfei Building NO.173 Des Voeux Road Central, Hong Kong
Factory:	SHENZHEN VIMOTO ELECTRONICS TECHNOLOGY LIMITED 903B,Builing c6,Hengfeng IndustrialPark, Hezhou, Xixiang Town,Bao an District, Shenzhen
Trade Mark:	VIMOTO
Tested:	October 18, 2011 - October 24, 2011
Test Voltage:	DC 5V for operating
Applicable Standards:	FCC Part 15:Subpart C ANSI C63.4:2003

The above equipment has been tested by Shenzhen BCTC Technology Co., Ltd. and found compliance with the requirements set forth in the technical standards mentioned above. The results of testing in this report apply only to the product/system, which was tested. Other similar equipment will not necessarily produce the same results due to production tolerance and measurement uncertainties.

Tested By: Davis ma **Date:** October 24, 2011
(Davis Ma)

Check By: Merry Zhao **Date:** October 24, 2011
(Merry Zhao)

Approved By: Lisa Zhu **Date:** October 24, 2011
(Lisa Zhu)



2 TEST RESULT SUMMARY

Standard	Item	Result
FCC Part 15 Subpart C: Clause 15.249	Conducted emission Test	PASS
	Radiation Emission Test	PASS
	Band Edge Test	PASS

- Note:**
1. The test result judgment is decided by the limit of test standard
 2. The information of measurement uncertainty is available upon the customer's request.



3 EUT DESCRIPTION

Product	Bluetooth Helmet Headset
Trade Mark	VIMOTO
Model	V5, V1, cool Rider, Easy Rider, 1098, V6, V8, V9, V10, v20, v30, v50, v60, v80, v90
Applicant	ITALY VIMOTO TECHNOLOGY(HK)LIMITED
Serial Number	N/A
Antenna Type	PCB Antenna
EUT Power Rating	DC 5V for operating
Temperature Range(Operating)	+15 ~+ 35°C
Operating Frequency	2402MHz to 2480MHz
Number of Channels	79 Channels

Note: N/A stand for no applicable.

Models difference

All models have the same constructions, circuit diagram and PCB layout. Only model name are different.



4 TEST METHODOLOGY

4.1. DECISION OF FINAL TEST MODE

The EUT was tested together with the below additional components, and configuration, which produced the worst emission levels, was selected and recorded in this report.

The measurement was performed at 3 axis for lie orientation, side orientation and stand orientation. The lie orientation is the worst mode, so only the worst mode test data was reported.

The following test mode was recorder in this report.

Test item	Test mode
Conducted emission Test	operating
Radiation Emission Test	CH1, CH40, CH79
Band Edge Test	CH1, CH79,

4.2. EUT SYSTEM OPERATION

1. Set up EUT with the support equipments.
2. Make sure the EUT transmitting continuously during the test.



5 SETUP OF EQUIPMENT UNDER TEST

5.1. DESCRIPTION OF SUPPORT UNITS

The EUT has been tested as an independent unit together with other necessary accessories or support units. The following support units or accessories were used to form a representative test configuration during the tests.

Manufacturer	Description	Model	Serial Number	FCC
NA	N/A	N/A	N/A	N/A

Note:

- 1) All the equipment/cables were placed in the worst-case configuration to maximize the emission during the test.
- 2) Grounding was established in accordance with the manufacturer's requirements and conditions for the intended use.

5.2. CONFIGURATION OF SYSTEM UNDER TEST

FOR OPERATING

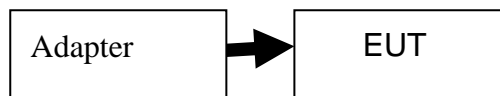



6 FACILITIES AND ACCREDITATIONS

6.1 FACILITIES

The test site used to collect the radiated data is located on the address of emitel (Shenzhen) Limited (FCC Registered Test Site Number: 746887) on Building 2, 171 Meihua Road, Futian District, Shenzhen, 518049 China. The Test Site is constructed and calibrated to meet the FCC requirements.

6.2 MEASUREMENT UNCERTAINTY

Where relevant, the following measurement uncertainty levels have been estimated for tests performed on the EUT as specified in CISPR 16-4-2:

Measurement	Frequency		Uncertainty
Conducted emissions	9kHz~30MHz		+/- 3.59dB
Radiated emissions	Horizontal	30MHz ~ 200MHz	+/- 4.77dB
		200MHz ~1000MHz	+/- 4.93dB
	Vertical	30MHz ~ 200MHz	+/- 5.04dB
		200MHz ~1000MHz	+/- 4.93dB

This uncertainty represents an expanded uncertainty expressed at approximately the 95% confidence level using a coverage factor of k=2.

7 TEST REQUIREMENTS

7.1. CONDUCTED EMISSION MEASUREMENT

7.1.1. LIMITS

FREQUENCY (MHz)	Class B (dBuV)	
	Quasi-peak	Average
0.15 - 0.5	66 - 56	56 - 46
0.50 - 5.0	56	46
5.0 - 30.0	60	50

NOTE:

- (1) The lower limit shall apply at the transition frequencies.
- (2) The limit decreases in line with the logarithm of the frequency in the range of 0.15 to 0.50 MHz.
- (3) All emanations from a class A/B digital device or system, including any network of conductors and apparatus connected thereto, shall not exceed the level of field strengths specified above.



7.1.2. TEST INSTRUMENTS

Conducted Emission Test Site				
Name of Equipment	Manufacturer	Model	Serial Number	Calibration Due
EMI Test Receiver	R&S	ESCI	100005	06/23/2012
LISN	AFJ	LS16	16010222119	09/29/2012
LISN(EUT)	Mestec	AN3016	04/10040	09/28/2012

NOTE: 1. The calibration interval of the above test instruments is 12 months and the calibrations are traceable to international system unit (SI).
2. N.C.R = No Calibration Request.

7.1.3. TEST PROCEDURES

The EUT was put on a wooden table which was 0.8metre high above the ground and connected to the AC mains through a Artificial Mains Network (A.M.N). The mains lead in excess of 1 m separating the EUT from the AMN was folded back and forth parallel to the lead so as to form a bundle with a length of 0.3m to 0.4m. The EUT was kept 0.4m from any other earthed conducting surface. Both sides of AC line were checked to find out the maximum conducted emission levels according to the test procedure during conducted emission test.

The bandwidth of the test receiver (ESCI) was set at 9KHz.

The frequency range from 150 KHz to 30 MHz was investigated.

The test data of the worst-case condition(s) was recorded.

7.1.4. TEST SETUP

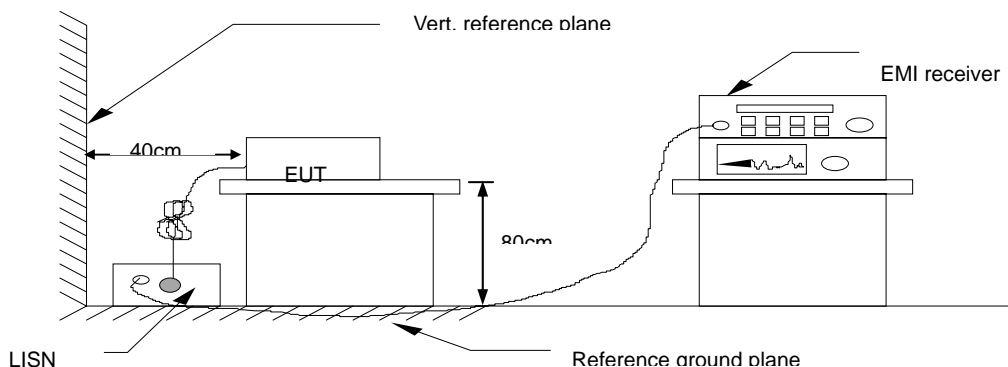

For the actual test configuration, please refer to the related item – Photographs of the Test Configuration.



7.1.5. Test Result

Model No.	V5	6dB Bandwidth	10 KHz
Environmental Conditions	26°C, 55% RH	Test Mode	OPERATING
Detector Function	Peak / Quasi-peak/AV	Test Result	Pass
Test By	Davis Ma		

NOTE:

L1 = Line One (Live Line) / L2 = Line Two (Neutral Line).

“---” denotes the emission level was or more than 2dB below the Average limit, so no re-check anymore.

Freq. = Emission frequency in MHz

Reading level(dBuV) = Receiver reading

Corr. Factor (dB) = Anttenuator factor + Cable loss

Level (dBuV) = Reading level(dBuV) + Corr. Factor (dB)

Limit (dBuV) = Limit stated in standard

Margin (dB) = Level (dBuV) – Limits (dBuV)

Q.P.=Quasi-Peak



Conducted Emission Measurement

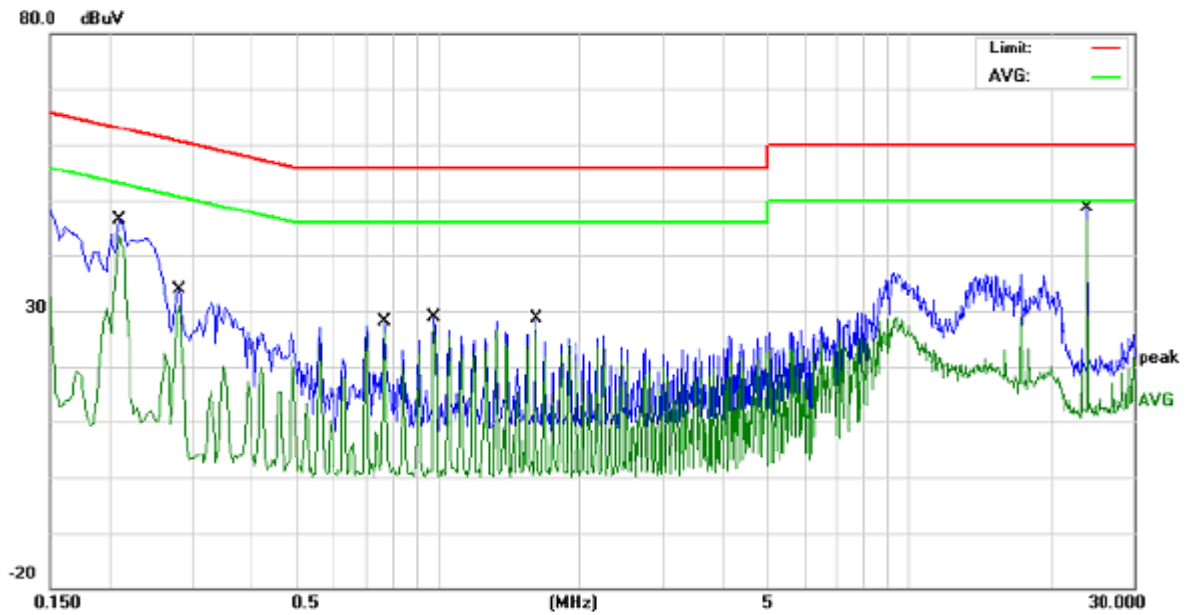

Site 843 Shielded Room

Phase: L1

Temperature: 26

Humidity: 55 %

No.	Mk.	Freq. MHz	Reading Level dBuV	Correct Factor dB	Measure- ment dBuV	Limit dBuV	Over dB	Detector	Comment
1		0.2100	33.34	10.74	44.08	63.20	-19.12	QP	
2		0.2100	32.92	10.74	43.66	53.20	-9.54	AVG	
3		0.2819	20.45	10.84	31.29	60.76	-29.47	QP	
4		0.2819	19.61	10.84	30.45	50.76	-20.31	AVG	
5		0.7700	16.46	10.39	26.85	56.00	-29.15	QP	
6		0.7700	15.79	10.39	26.18	46.00	-19.82	AVG	
7		0.9820	17.74	10.26	28.00	56.00	-28.00	QP	
8		0.9820	17.03	10.26	27.29	46.00	-18.71	AVG	
9		1.6140	17.57	10.27	27.84	56.00	-28.16	QP	
10		1.6140	17.10	10.27	27.37	46.00	-18.63	AVG	
11		23.9980	37.69	10.28	47.97	60.00	-12.03	QP	
12	*	23.9980	36.56	10.28	46.84	50.00	-3.16	AVG	

*:Maximum data x:Over limit l:over margin

<Reference Only



Conducted Emission Measurement

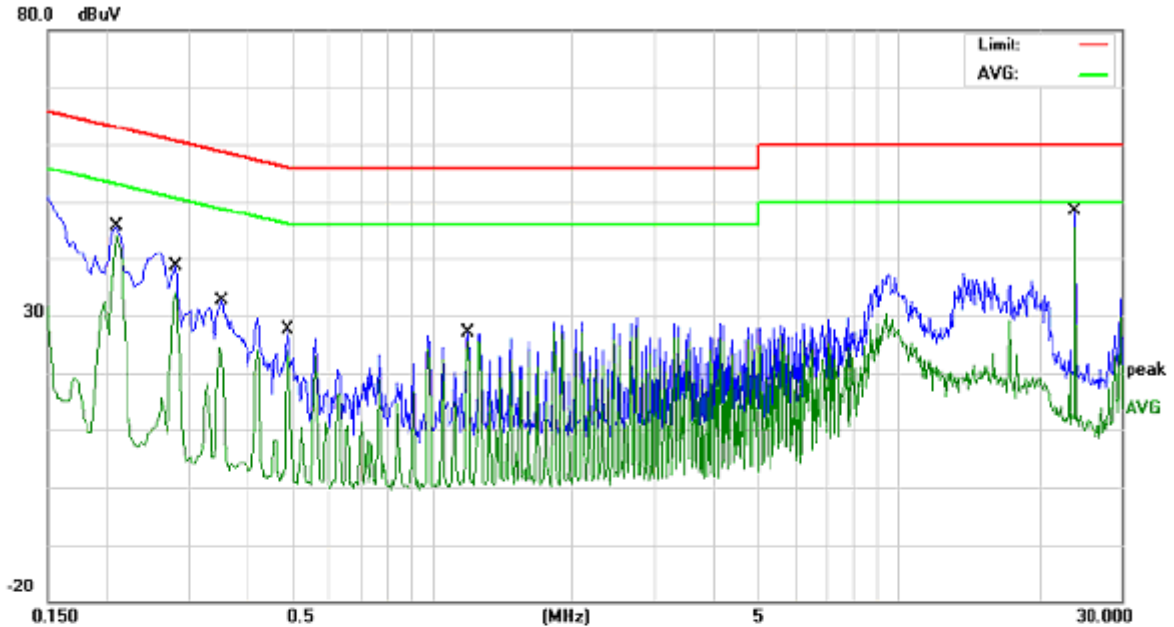

Site 843 Shielded Room

Phase: *N*

Temperature: 26

Humidity: 55 %

No.	Mk.	Freq. MHz	Reading Level dBuV	Correct Factor dB	Measure- ment dBuV	Limit dBuV	Over dB	Detector	Comment
1		0.2100	33.52	10.74	44.26	63.20	-18.94	QP	
2		0.2100	33.54	10.74	44.28	53.20	-8.92	AVG	
3		0.2819	24.83	10.84	35.67	60.76	-25.09	QP	
4		0.2819	22.94	10.84	33.78	50.76	-16.98	AVG	
5		0.3540	14.25	10.78	25.03	58.87	-33.84	QP	
6		0.3540	11.23	10.78	22.01	48.87	-26.86	AVG	
7		0.4900	14.62	10.56	25.18	56.17	-30.99	QP	
8		0.4900	13.47	10.56	24.03	46.17	-22.14	AVG	
9		1.1940	15.80	10.26	26.06	56.00	-29.94	QP	
10		1.1940	14.96	10.26	25.22	46.00	-20.78	AVG	
11		23.9980	37.65	10.28	47.93	60.00	-12.07	QP	
12	*	23.9980	36.50	10.28	46.78	50.00	-3.22	AVG	

*:Maximum data x:Over limit !:over margin

(Reference Only)



7.2. Radiation Emission Test

7.2.1. Limits

According to 15.249 the field strength of emissions from intentional radiators operated under these frequencies bands shall not exceed the following:

Fundamental Frequency	Field Strength of Fundamental		Field Strength of Spurious	
	mV/meter	dBuV/meter	uV/meter	dBuV/meter
902-928MHz	50	94	500	54
2400-2483.5MHz	50	94	500	54
5725-5875MHz	50	94	500	54
24.0-24.25GHz	250	108	2500	68

The above field strength limits are specified at a distance of 3 meters. Emissions radiated outside of the specified bands, shall be according to the general radiated limits in 15.209 as following:

Frequencies (MHz)	Field strength uV/meter	Measurement distance (meters)
0.009-0.490	2400/F(kHz)	300
0.490-1.705	24000/F(kHz)	30
1.705-30.0	30	30
30-88	100	3
88-216	150	3
216-960	200	3
Above 960	500	3

As shown in 15.35(b), for frequencies above 1000MHz, the field strength limits are based on average detector, however, the peak field strength of any emission shall not exceed the maximum permitted average limits, specified above by more than 20dB under any condition of modulation.

Frequency Range of Radiated Measurement

According to 15.33(a), the intentional radiator operates below 10GHz, must be measured up to the tenth harmonic of the highest fundamental frequency or 40GHz, whichever is lower



7.2.2. TEST INSTRUMENT

966 Chamber				
Name of Equipment	Manufacturer	Model	Serial Number	Calibration Due
EMI Test Receiver	ROHDE&SCHWARZ	ESCI	100005	06/23/2012
Spectrum Analyzer	R&S	FSU	100114	04/14/2012
Pre Amplifier	H.P.	HP8447E	2945A02715	06/23/2012
Pre-Amplifier	Compliance	PAM0118	1360976	06/04/2012
Bilog Antenna	SUNOL Sciences	JB3	A021907	06/10/2012
Horn Antenna	Compliance	CE18000	001	06/10/2012
Cable	TIME MICROWAVE	LMR-400	N-TYPE04	06/09/2012
Cable	TIME MICROWAVE	--	--	06/09/2012
System-Controller	CCS	N/A	N/A	N.C.R
Turn Table	CCS	N/A	N/A	N.C.R
Antenna Tower	CCS	N/A	N/A	N.C.R

7.2.3. Test procedure

The EUT was placed on a turn table which was 0.8 meter above ground. The turn table can rotate 360 degrees to determine the position of the maximum emission level. The EUT was set 3 meters away from the receiving antenna which was mounted on a antenna tower. At the frequency band of 30MHz to 1GHz, The measuring antenna moved up and down to find out the maximum emission level. It moved from 1 to 4 m for horizontal and vertical polarizations. The broadband antenna (calibrated by dipole antenna) was used as a receiving antenna. At the frequency band of 1GHz to 18GHz, The measuring antenna moved from 1 to 4 m for horizontal and vertical polarization. The horn antenna was used as a receiving antenna.

The resolution bandwidth and video bandwidth of the test receiver was 120 KHz and 300KHz for Quasi-peak detection at frequency below 1GHz.

The resolution bandwidth and video bandwidth of the test receiver was 1MHz and 3MHz for Peak emssion mesurement above 1GHz .

For Average emssion above 1GHz , the resolution bandwidth and video bandwidth of the test receiver was 1MHz and 10Hz.

The EUT was tested in Chamber Site.

The test data of the worst case condition(s) was reported on the following pages.



7.2.4 Test setup diagram

Below 1GHz

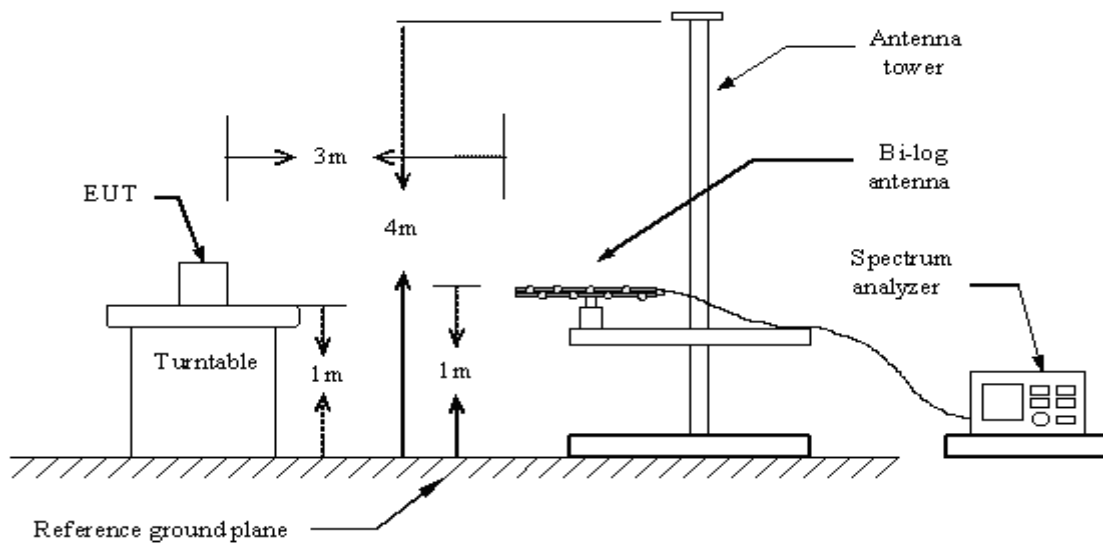

Above 1GHz

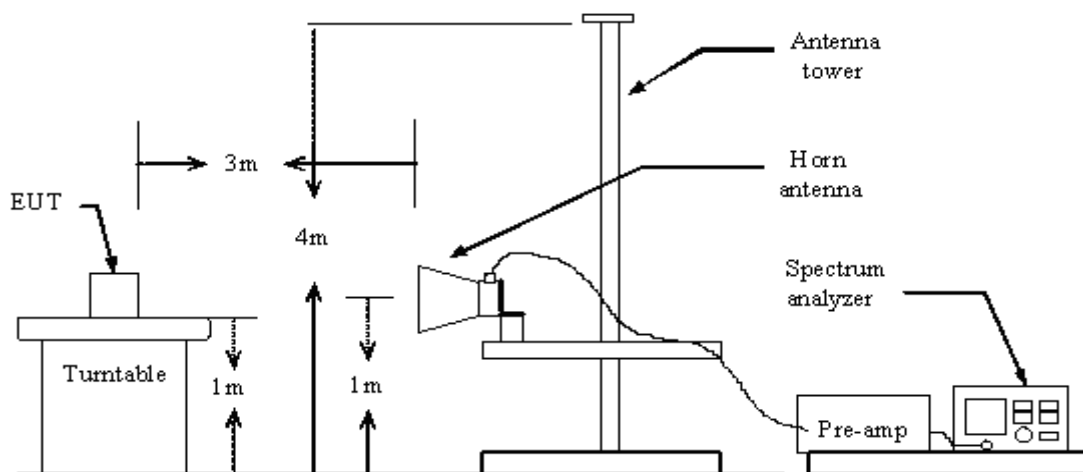



7.2.5. Test Result

A. Fundamental Radiated Emission Data

Product:	Bluetooth Helmet Headset	Test mode:	CH Low~CH High
Test Item:	Fundamental Radiated Emission Data	Temperature:	25°C
Test Voltage:	DC 5V	Humidity:	56%RH
Test Result:	PASS		

CH Low

Freq. (MHz)	Emission(dBuV/m) Peak Detector/ AV	HORIZ/ VERT	Limits(dBuV/m) Peak/AVERAGE	Margin (Db)
2402	92.6/ 74.5	HORIZ	114/94	21.4/19.5
2402	95.6 / 77.2	VERT	114/94	18.4/16.8

CH Middle

Freq. (MHz)	Emission(dBuV/m) Peak Detector/ AV	HORIZ/ VERT	Limits(dBuV/m) Peak/AVERAGE	Margin (Db)
2441	92.8/74.2	HORIZ	114/94	21.2/19.8
2441	94.7/75.5	VERT	114/94	19.3/18.5

CH High

Freq. (MHz)	Emission(dBuV/m) Peak Detector/ AV	HORIZ/ VERT	Limits(dBuV/m) Peak/AVERAGE	Margin (Db)
2480	93.3/76.6	HORIZ	114/94	20.7/17.4
2480	95.5/78.2	VERT	114/94	18.5/15.8



B.Harmonics Radiated Emission Data

Product:	Bluetooth Helmet Headset	Test mode:	CH Low~CH High
Test Item:	Radiated Emission Data	Temperature:	25°C
Test Voltage:	DC 5V	Humidity:	56%RH
Test Result:	PASS		

CH Low

Freq. (MHz)	Emission(dBuV/m) Peak Detector	HORIZ/ VERT	Limits(dBμV/m) Peak/ Average	Margin (dB)
4804.12	-	H/V	74.0/54.0	-
7206.18	-	H/V	74.0/54.0	-
9608.24	-	H/V	74.0/54.0	-
12010.3	-	H/V	74.0/54.0	-
14412.36	-	H/V	74.0/54.0	-
16814.42	-	H/V	74.0/54.0	-

CH Midde

Freq. (MHz)	Emission(dBμV/m) Peak Detector	HORIZ/ VERT	Limits(dBμV/m) Peak/ Average	Margin (dB)
4882.18	-	H/V	74.0/54.0	-
7323.27	-	H/V	74.0/54.0	-
9764.36	-	H/V	74.0/54.0	-
12205.45	-	H/V	74.0/54.0	-
14646.54	-	H/V	74.0/54.0	-
17087.63	-	H/V	74.0/54.0	-



CH High

Freq. (MHz)	Emission(dBμV/m) Peak Detector	HORIZ/ VERT	Limits(dBμV/m) Peak/ Average	Margin (dB)
4960.26	-	H/V	74.0/54.0	-
7440.39	-	H/V	74.0/54.0	-
9920.52	-	H/V	74.0/54.0	-
12400.65	-	H/V	74.0/54.0	-
14880.78	-	H/V	74.0/54.0	-
17360.91	-	H/V	74.0/54.0	-

Note: - means the emission is too low at least 20dB to the limit.

C. General Radiated Emission Data

Product:	Bluetooth Helmet Headset	Test mode:	transmitting
Test Item:	Radiated Emission Data	Temperature:	25°C
Test Voltage:	DC 5V	Humidity:	56%RH
Test Result:	PASS		

Freq. (MHz)	Emission(dBuV/m) Peak Detector	HORIZ/ VERT	Limits(dBuV/m) Peak/ACERAGE	Margin (Db)
96.8	29.2	HORIZ	43.5	14.3
96.8	31.3	VERT	43.5	12.2
195.5	26.4	HORIZ	43.5	17.1
195.5	29.5	VERT	43.5	14.0
432.4	28.8	HORIZ	46	17.2
432.4	31.3	VERT	46	14.7



7.3. Band edge test

7.3.1. Limits

According 15.249(d), Emission radiated outside of the specified frequency bands, except for harmonics, shall be attenuated by at least 50dB below the level of the fundamental or to the general radiated emission limits in section 15.209, whichever is the lesser attenuation.

7.3.2. TEST INSTRUMENT

Same as 7.2.2

7.3.3. Test procedure

1. The EUT was placed on a turntable which is 0.8m above ground plane.
2. Set EUT as continuous transmitting mode.
3. Set the EUT work on the CH1, CH79 individually.
4. Set SPA Frequency = Operation frequency, for PK: RBW = 1MHz, VBW = 3MHz
5. Set SPA trace max hold, then view.

7.3.4. Test setup diagram

Same as 7.2.4



7.3.5. Test result

Product:	Bluetooth Helmet Headset	Test mode:	CH Low,CH High
Test Item:	bandedge	Temperature:	25°C
Test Voltage:	DC 5V	Humidity:	56%RH
Test Result:	PASS		

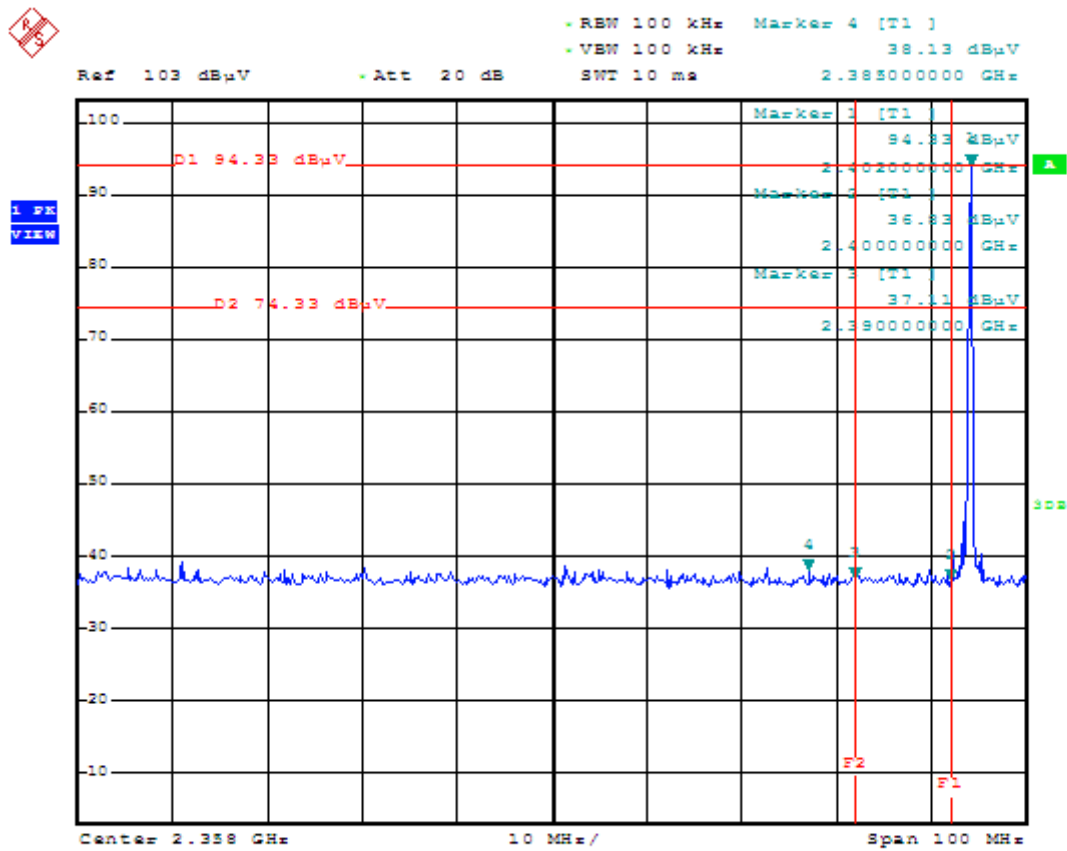

Emission in the Restricted Bands

Frequency [MHz]	dBc [dB]	AV [dBμV/m]	Polarity (H/V)	AV limit [dBμV/m]
2310	-	35.1	V	54
2385	-	36.6	V	54
2390	-	36.3	V	54



Ref 103 dB μ V *Att 20 dB *RBW 100 kHz Marker 2 [T1]
 *VBW 100 kHz 34.89 dB μ V
 SWT 10 ms 2.483500000 GHz

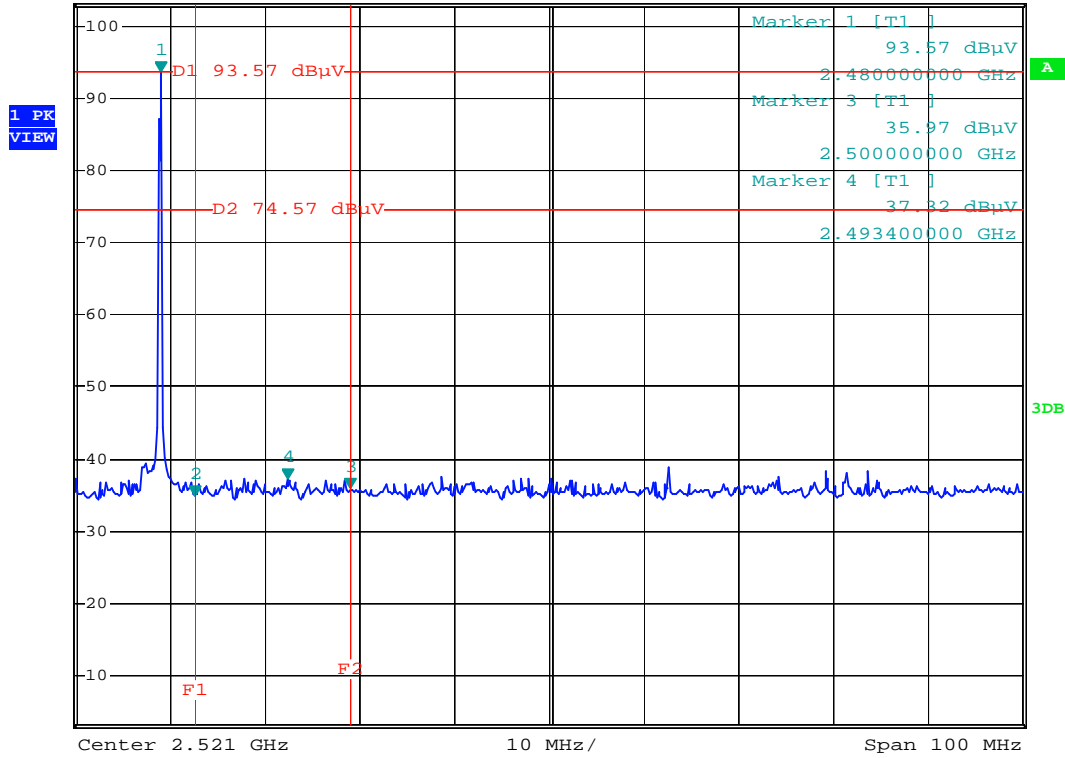

Emission in the Restricted Bands

Frequency [MHz]	dBc [dB]	AV [dB μ V/m]	Polarity (H/V)	AV limit [dB μ V/m]
2483.5	-	33.72	V	54
2493.4	-	35.81	V	54
2500	-	34.73	V	54

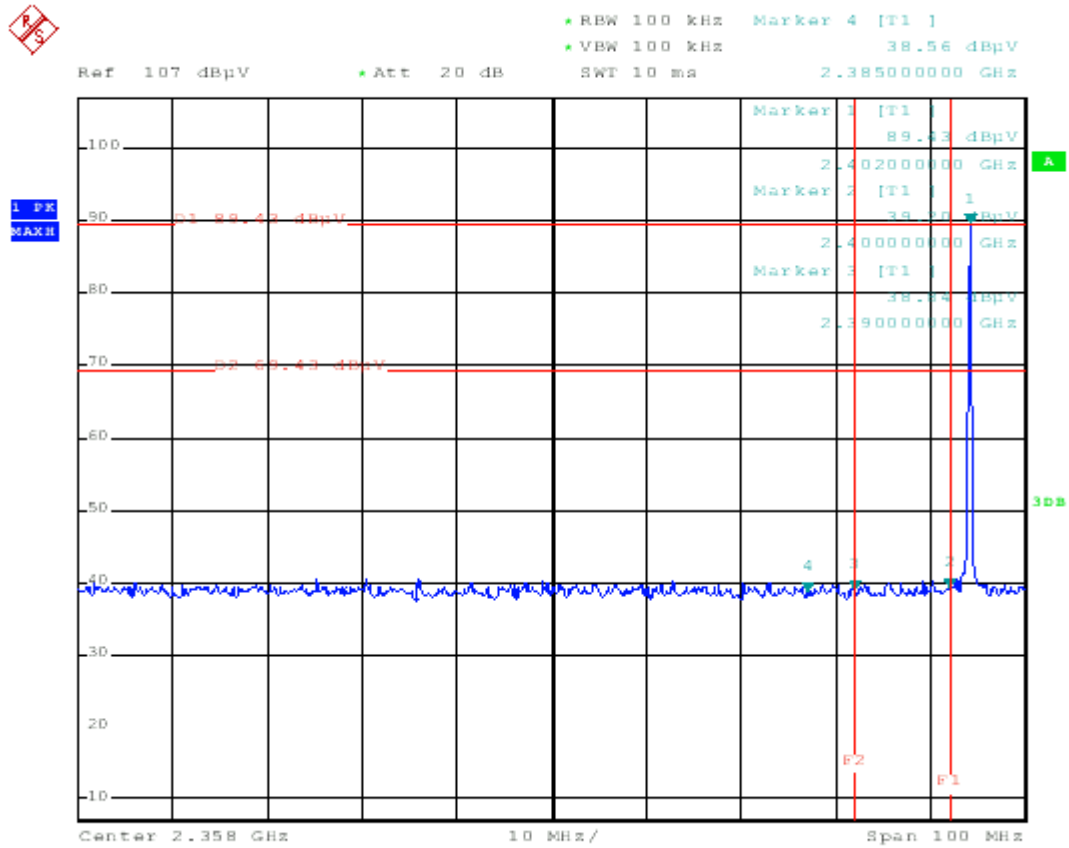

Emission in the Restricted Bands

Frequency [MHz]	dBc [dB]	AV [dBμV/m]	Polarity (H/V)	AV limit [dBμV/m]
2310	-	34.8	H	54
2385	-	35.1	H	54
2390	-	35.2	H	54

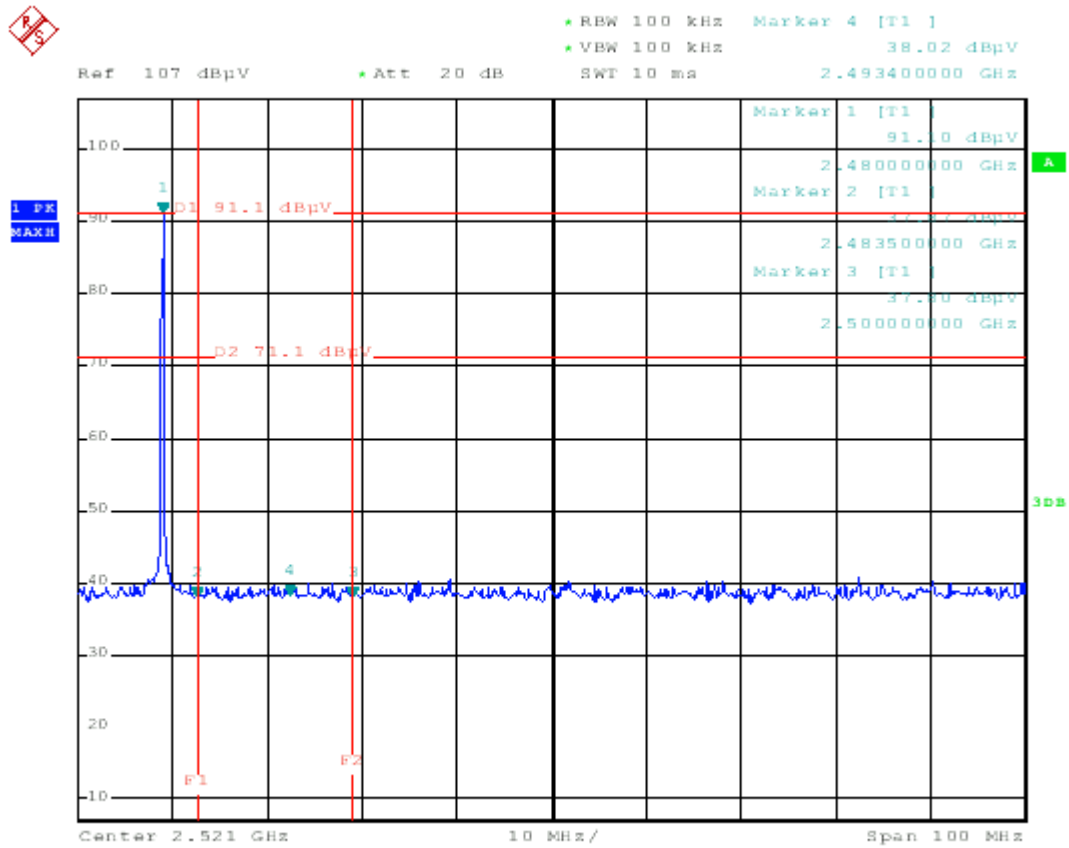

Emission in the Restricted Bands

Frequency [MHz]	dBc [dB]	AV [dBμV/m]	Polarity (H/V)	AV limit [dBμV/m]
2483.5	-	33.16	H	54
2493.4	-	34.37	H	54
2500	-	34.12	H	54



8. Antenna requirement

8.1. Standard applicable

For intentional device, according to FCC 47 CFR Section 15.203, an intentional radiator shall be designed to ensure that no antenna other than that furnished by the responsible party shall be used with the device.

8.2. Antenna connected construction

The antenna used in this product is PCB antenna and no consideration of replacement.