

SINGLE-PROPELLER 4CH REMOTE HELICOPTER OPERATING INSTRUCTION

FOR MODEL NUMBER :FX061

1 Introduction

Please read the handbook carefully for handling the helicopter quickly and safely as well as keep it appropriately so that you can make a further reference.

2 Warning

- 1.This product is not a toy. It's a complex combination which gather the electronics, mechanics and aero dynamics all together. It requires proper setup and precise modulation to avoid accident. We will not undertake any responsibility of the injury caused while you play the helicopter and we will not make any compensation.
- 2.Please do not overcharge the battery that may result in fire or explosion. Please stop charging immediately when the battery is hot during charging. Please use the charger which is compatible with the product please avoid short circuit.
- 3.This product is suitable for people older than 14 years who had got the experience of playing 4 channel helicopter.
- 4.When the helicopter is flying, stop the spinning wing by any reason, or any crash will lead to damage or burning, in this case, please turn down the accelerator immediately and keep the throttle joystick at the lowest position.
- 5.Please keep far away from crowds, buildings or high-voltage wire to avoid danger and damage while you are playing the helicopter.

3 Attention

- 1.Since the helicopter is radio control, please make sure to use new batteries or full power batteries. Do not use exhausted batteries, or it will lead to the helicopter losing control. also make sure the remote controller batteries' power are full enough.
- 2.Do not let any appliance components become damp, or it will lead to electrical equipment damage.
- 3.Please finish checking for the wireless device in available distance before making helicopter fly.
- 4.Please do cleaning by using a cloth but not too wet when the helicopter get dirty, dissolvent will damage plastic and composite material components.
- 5.Please disconnect the connecting line of batteries and helicopter, make batteries of nonuse helicopter be full of charge once for one month
- 6.Do not make helicopter be out of controlling distance in the process of flying, or you will lose the control of helicopter.
- 7.Please confirm the server execute command from remote controller well, server which out of action will lead to unpredictable danger.
- 8.Please confirm there is no screw and nut missing, or fetching away, no broken components or components assemble unsuitably. Check carefully and make sure the main rotor, especially the part close to propeller joint is not broken, broken components or components assemble unsuitably will influences the flying
- 9.Please make sure the connector and connecting clasps of propeller isn't fetch away, replace the connector and connecting clasps which fetching away, or it will influence helicopter flying, even bring the danger of losing control.
- 10.Make sure all connecting line of batteries and motor fasten enough,. Continuity shake and drastic action during flying will make the power connector fetch away and the helicopter out of control.
- 11.After flying by using up two pieces of batteries, please make the motor cool down first before you want to make it fly again, or it will reduce the lifespan of batteries. After flying, do not touch the motor since the temperature of motor is high at that moment.

4 Specifications

Length:276mm Height:113mm Width:58 mm
Dia. Of main blade:286mm Transmitter: 4 CH Total weight:89 g (battery included)
Battery:500mAh / 3.7V rechargeable Lithium battery
FX061 receiving device:3 in 1 receiver(receiver, speed controller, gyroscope).
Servo:weight 2.0 g / speed 0.11 sec / 60°C3.7V/torque0.5kg /dimension20.2*8.5*24.7mm

5 Superiority

- 1)The combination of prompt servos ensures various precise flight.
- 2)The high-volume 500 mAh/3.7V Li-Po battery ensures the time for flying will be long enough.
- 3)Good maneuverability , high-speed
- 4)Protection against stuck will reduce the damage while the helicopter crashed hardly.

6 Transmitter features

- 1.The shape design accords with the ergonomics.
- 2.4CH micro-computer as the encoder ,GFSK modulation;
output power:5200mW;current drain:150mA;Power:1.5V*6AA dry cell.

7 Parts name of helicopter

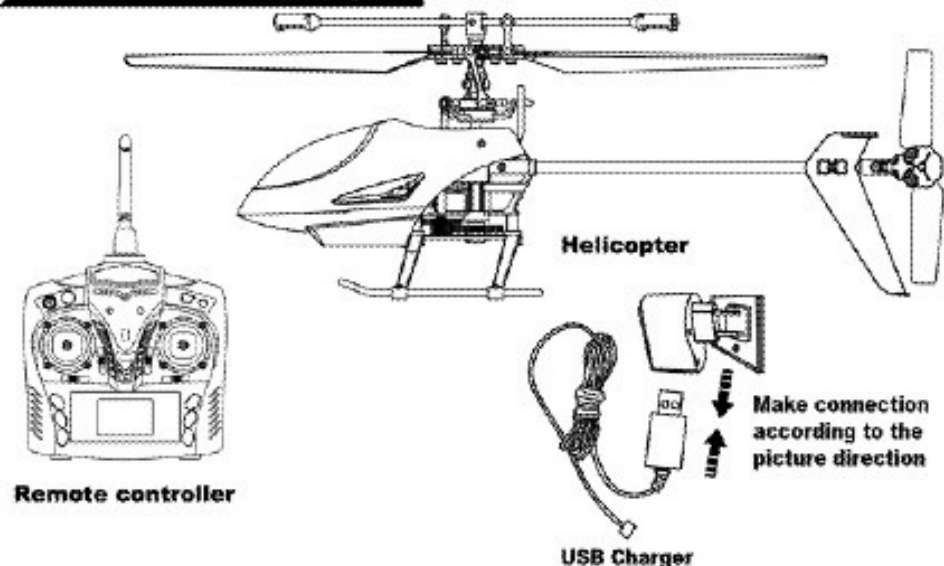

8 Main structure drawing of helicopter

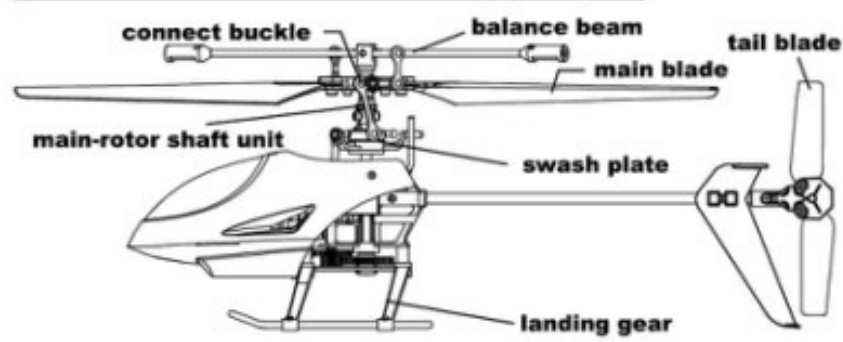

9 Parts name of the remote controller

(The general instruction manual, remote control mode, please refer to the actual product in the package.)

Mode 1 (The left-hand throttle) Mode 2 (The right-hand throttle)



10 Mode change

There are primary mode and advance mode available for the helicopter, the led indicator lights up means in advance mode status, lights out means in primary mode status. Primary mode makes the helicopter move and react slowly, suitable for the freshman. Advance mode makes the helicopter move and react quickly, suitable for the skilled man.

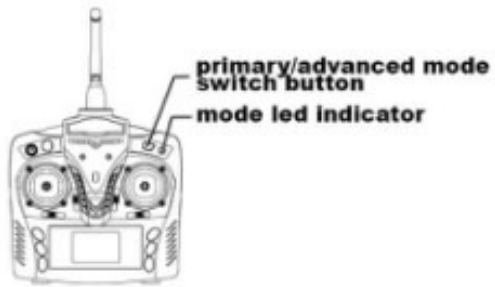

11 Environment for playing

1. Playing on the sunny day.
2. Do not play the helicopter on the bad weather specially with strong wind.
3. Choosing spacious place indoor or outdoor to play and making sure there are no barriers, pets or people nearby.
4. Far away from wet environment
5. Far away from heat source

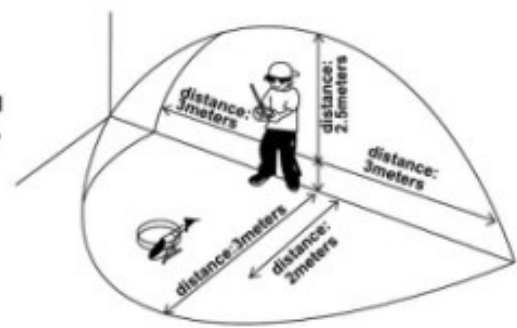

12 Charge

You can use the helicopter normally by taking about 90 minutes to charge for batteries fully. Any overcharge may lead to batteries damage, scald, fire risk and so on.

Attention:

1. Making sure the voltage and connector plug of adapter are tally with the local charging standard.
2. You could not leave when the battery is in the process of charging.
3. The battery would be hot when the helicopter finished flying, please wait at least 30 minutes to cool it for protection.
4. Do not throw the battery into the fire to avoid explosion.

Warning: If helicopter is out of use, please disconnect batteries and helicopter to avoid battery overdischarge.

CHARGE ILLUSTRATION

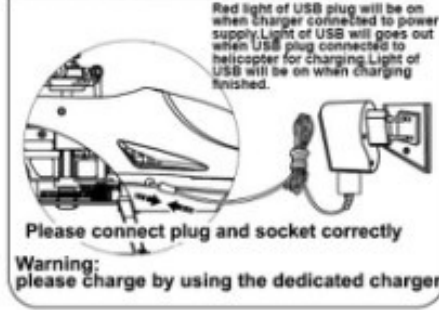

13 Frequency matching

Match the frequency of this model for the first time using. When matching the MHz, equal MHz can not be used at the same time for avoiding interference. Matching may out of work if here is some interference. Operated way are as follow:

1. Push the throttle joystick to the lowest position and turn on the power of remote controller at the same time, elongate the antenna.
2. Turn on the power of the helicopter, put the helicopter on a spacious floor flatly, far away from people or objects. Leave the helicopter at least 2-3 meters away, while the tail aimed at you, the red lights of the head flash quickly, which means the helicopter is searching the remote control frequency automatically. When the red lights of the head flash slowly, it means the matching process is finished, you can be ready to fly.
3. Please make sure again that the flying place is safe, when there is no other people or objects around, you can get ready to fly.





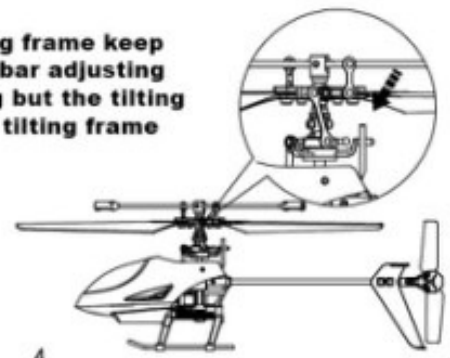





14 Swash plate adjustment

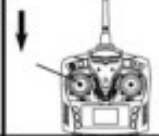
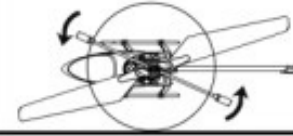
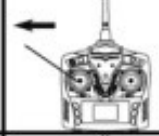
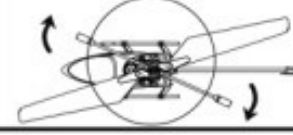
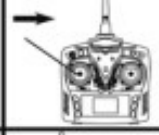









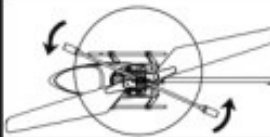

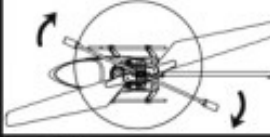

1. Make sure the needle of all spin button in remote controller are in the middle condition.
2. Make the left and right of the tilting frame keep horizontal by steering engine stay bar adjusting
3. If the helicopter can keep hovering but the tilting frame tilted, no need to adjust the tilting frame if the helicopter fly well.



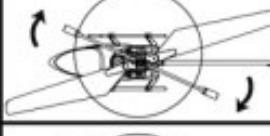
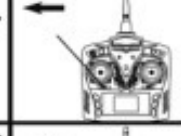
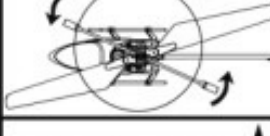
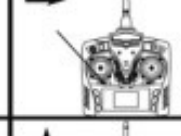

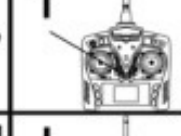

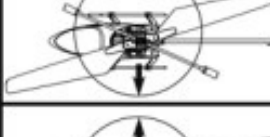
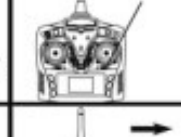











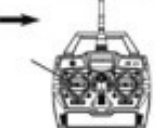

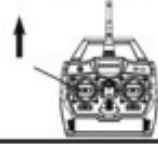
15 Operated way

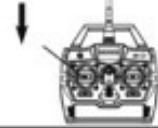







Mode 1 (The left-hand throttle)

Ascend		When you push up the left joystick(throttle) the spinning speed of the main rotor blade increases and the helicopter begins to ascend .	
Descend		When pushing down the left joystick (throttle), the spinning speed of the main rotor blade decreases and the helicopter begins to descent. When pushing down to the bottom, the main rotor blade stop.	
Left		When pushing the left-hand joystick to left ,the nose of helicopter will turn to left.	
Right		When pushing the left-hand joystick to right, the nose of helicopter will turn to right .	
Forward		When you push up the right-hand joystick ,the nose of helicopter will down then the helicopter moves forward .	
Backward		When you push down the right-hand joystick ,the nose of helicopter will up then the helicopter moves backward .	
Move left		When pushing the right-hand joystick to left ,the fuselage sloping to left then the helicopter moves to left as well.	
Move right		When pushing the right-hand joystick to right ,the fuselage sloping to right then the helicopter moves to right as well.	

Tail balance fine adjustment (clockwise rotation)		If no moving direction joystick, the tail is off path toward the right, make the balance fine adjustment knob do clockwise rotation until the tail stop skewing toward the right.	
Tail balance fine adjustment (anticlockwise rotation)		If no moving direction joystick, the tail is off path toward the left, make the balance fine adjustment knob do anticlockwise rotation until the tail stop skewing toward the left	
Rudder trimmer (push up)		The helicopter is flying up and keep moving backward if you didn't trim the servo trimmer. Push the servo trimmer up until the helicopter stop moving backward.	
Rudder trimmer (push down)		The helicopter is flying up and keep moving forward if you didn't trim the servo trimmer. Push the servo trimmer down until the helicopter stop moving forward.	
Rudder trimmer (turn left)		The helicopter may circle clockwise in the sky if you didn't trim the rudder trimmer. Push the rudder trimmer to left until the helicopter stop circling.	
Rudder trimmer (turn right)		The helicopter may circle anticlockwise in the sky if you didn't trim the rudder trimmer. Push the rudder trimmer to right until the helicopter stop circling.	
Throttle trimmer (push up)		When you push the throttle joystick up but the helicopter unable to fly . Trim the throttle joystick up until the helicopter start flying.	
Throttle trimmer (push down)		If the helicopter is dynamic when you push the throttle joystick down to the bottom .Trim the throttle joystick down until the helicopter stop flying.	
Sideward fly trimmer (turn left)		The helicopter is flying up and keep moving right sideways if you didn't trim the left-hand joystick.Push the sideward trimmer to left until the helicopter stop moving right sideways	
Sideward fly trimmer (turn right)		The helicopter is flying up and keep moving left sideways if you didn't trim the left-hand joystick.Push the sideward trimmer to right until the helicopter stop moving left sideways	

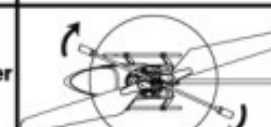
Mode 2 (The right-hand throttle)

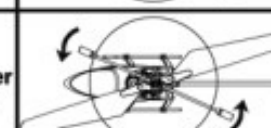
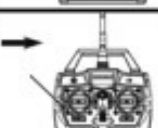
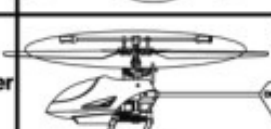
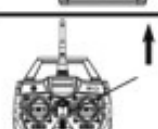
Ascend		When you push up the right joystick(throttle),the spinning speed of the main rotor blade increases and the helicopter begins to ascend .	
Descend		When you push down the right joystick (throttle),the spinning speed of the main rotor blade decreases and the helicopter begins to descent.	
Left		When pushing the left-hand joystick to left ,the nose of helicopter will turn to left.	
Right		When pushing the left-hand joystick to right, the nose of helicopter will turn to right .	
Forward		When you push up the left-hand joystick ,the nose of helicopter will down then the helicopter moves forward .	
Backward		When you push down the left-hand joystick ,the nose of helicopter will up then the helicopter moves backward .	
Move left		When pushing the right-hand joystick to left ,the fuselage sloping to left then the helicopter moves to left as well.	
Move right		When pushing the right-hand joystick to right ,the fuselage sloping to right then the helicopter moves to right as well.	
Tail balance fine adjustment (clockwise rotation)		If no moving direction joystick, the tail is off path toward the right, make the balance fine adjustment knob do clockwise rotation until the tail stop skewing toward the right.	
Tail balance fine adjustment (anticlockwise rotation)		If no moving direction joystick, the tail is off path toward the left, make the balance fine adjustment knob do anticlockwise rotation until the tail stop skewing toward the left	

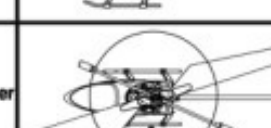
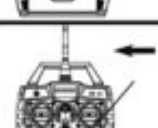
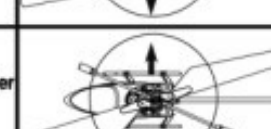
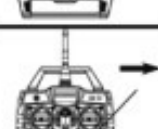
Rudder trimmer (push up)		The helicopter is flying up and keep moving backward if you didn't trim the servo trimmer. Push the servo trimmer up until the helicopter stop moving backward.	
Rudder trimmer (push down)		The helicopter is flying up and keep moving forward if you didn't trim the servo trimmer. Push the servo trimmer down until the helicopter stop moving forward.	
Rudder trimmer (turn left)		The helicopter may circle clockwise in the sky if you didn't trim the rudder trimmer. Push the rudder trimmer to left until the helicopter stop circling.	
Rudder trimmer (turn right)		The helicopter may circle anticlockwise in the sky if you didn't trim the rudder trimmer. Push the rudder trimmer to right until the helicopter stop circling.	
Throttle trimmer (push up)		When you push the throttle joystick up but the helicopter unable to fly . Trim the throttle joystick up until the helicopter start flying.	
Throttle trimmer (push down)		If the helicopter is dynamic when you push the throttle joystick down to the bottom .Trim the throttle joystick down until the helicopter stop flying.	
Sideward fly trimmer (turn left)		The helicopter is flying up and keep moving right sideway if you didn't trim the left-hand joystick.Push the sideway trimmer to left until the helicopter stop moving right sideway	
Sideward fly trimmer (turn right)		The helicopter is flying up and keep moving left sideway if you didn't trim the left-hand joystick.Push the sideway trimmer to right until the helicopter stop moving left sideway	

16 Checking items before / after playing

- 1.Check carefully whether there are loose screws or damaged parts. Stop flying if there exist such a problem .Renew the broken parts .
- 2.Clean the helicopter after playing .
- 3.To be on the safe side, making sure there were no defects of all parts .
- 4.Keep the helicopter in a cool and dry place. Avoid sunshine directly and far away from heat .

Caution: The user is cautioned that changes or modifications not expressly approved by the party responsible for compliance could void the user's authority to operate the equipment.

This device complies with Part 15 of the FCC Rules. Operation is subject to the following two conditions: (1) this device may not cause harmful interference, and (2) this device must accept any interference received, including interference that may cause undesired operation.

Note: This equipment has been tested and found to comply with the limits for a Class B digital device, pursuant to part 15 of the FCC Rules. These limits are designed to provide reasonable protection against harmful interference in a residential installation. This equipment generates, uses and can radiate radio frequency energy and, if not installed and used in accordance with the instructions, may cause harmful interference to radio communications. However, there is no guarantee that interference will not occur in a particular installation. If this equipment does cause harmful interference to radio or television reception, which can be determined by turning the equipment off and on, the user is encouraged to try to correct the interference by one or more of the following measures:

- Reorient or relocate the receiving antenna.
- Increase the separation between the equipment and receiver.
- Connect the equipment into an outlet on a circuit different from that to which the receiver is connected.
- Consult the dealer or an experienced radio/TV technician for help.