

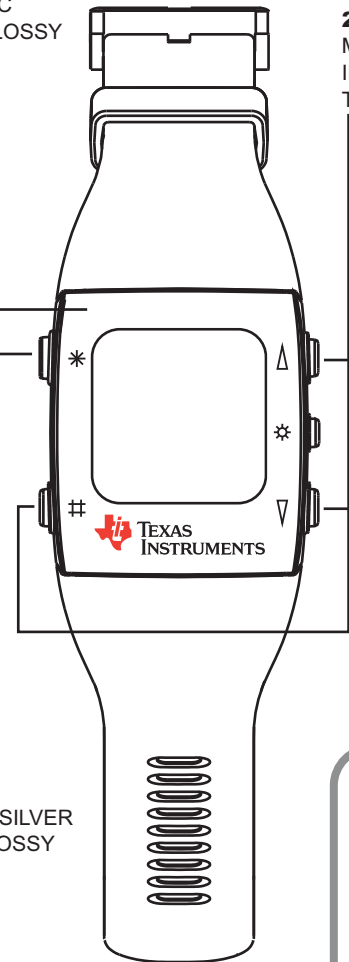

**BACKPLATE**  
 MATERIAL : STAINLESS STEEL  
 TEXTURE : SANDBLAST  
 ENGRAVED TEXTS & ICONS

**LENS**  
 MATERIAL : ACRYLIC  
 TEXTURE : HIGH GLOSSY



**10H KEYS**  
 MATERIAL : ABS  
 ELECTROPLATING : SILVER  
 TEXTURE : HIGH GLOSSY

**2,4,8H KEYS**  
 MATERIAL : ABS  
 INJ. COLOR : PMS BLACK C  
 TEXTURE : HIGH GLOSSY

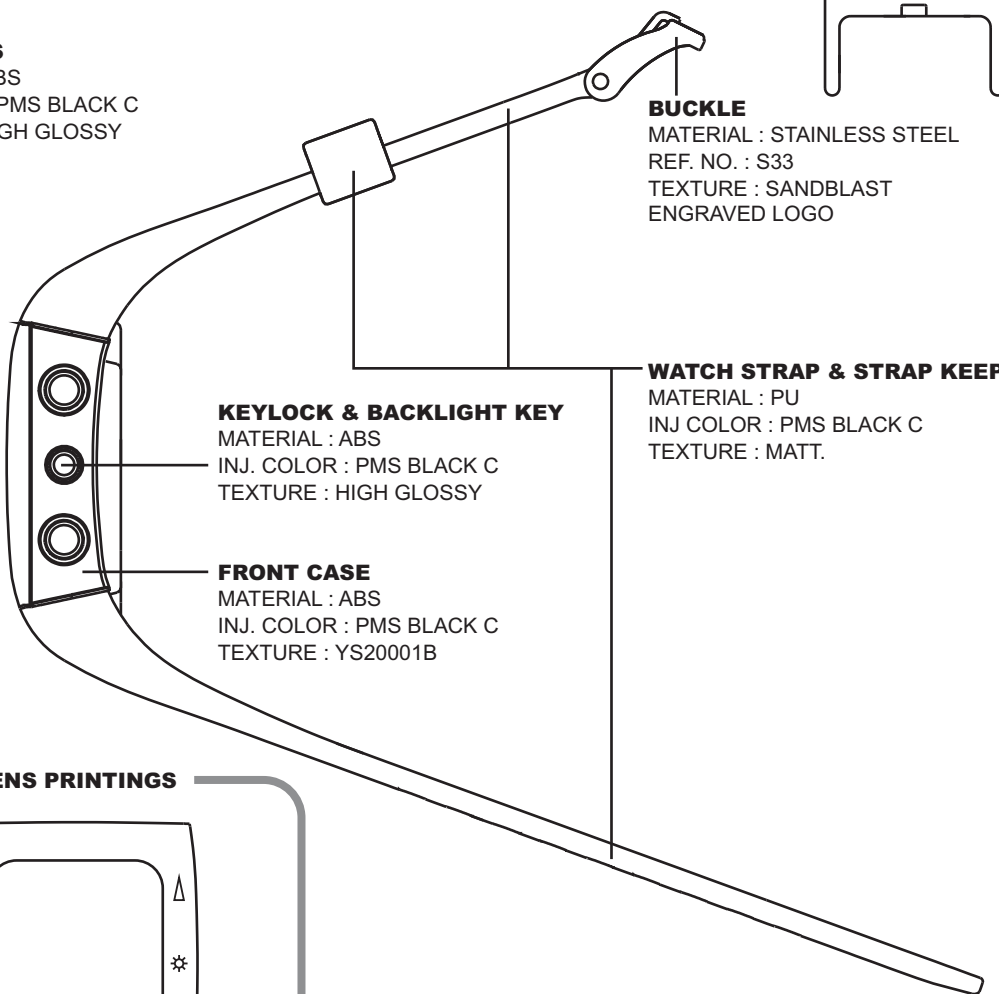

**BUCKLE**  
 MATERIAL : STAINLESS STEEL  
 REF. NO. : S33  
 TEXTURE : SANDBLAST  
 ENGRAVED LOGO

**WATCH STRAP & STRAP KEEPER**  
 MATERIAL : PU  
 INJ COLOR : PMS BLACK C  
 TEXTURE : MATT.

**KEYLOCK & BACKLIGHT KEY**  
 MATERIAL : ABS  
 INJ. COLOR : PMS BLACK C  
 TEXTURE : HIGH GLOSSY

**FRONT CASE**  
 MATERIAL : ABS  
 INJ. COLOR : PMS BLACK C  
 TEXTURE : YS20001B

**LENS PRINTINGS**

BACKGROUND :  
 COLOR : PMS BLACK C

OTHER TEXTS & ICONS : **1**  
 COLOR : PMS 427 C

LOGO : "TX" COLOR **2**  
 IN RED PMS032C



scale 1:1  
 V.A. size : 23x23mm  
 Date : 1 Sept 07