

Revision history : (Compared to ver 2.0A)

- 1. Replaced Emualtion circuit with FTDI instead of ICDI
- 2. Re-arranged the pin assignment of the P1,P2,P3,P4 to align with the MCU convention.
- 3. Added pull-down on the LED driver to prevent them from floating.
- 4.

			Texas Instruments 66/3 Bagmane Tech Park CV Raman Nagar Bangalore +91-80-2509-9599		
	<b>Approval</b>	<b>Date</b>	<b>Title</b> CC3101 LP Ver 3.0 ENG1		
<b>Designer</b>	Prajay M	Date			
<b>Drawn By</b>	Prajay M	Date	<b>Size</b> A2	<b>Project No</b> <Project Number>	<b>Rev</b> B
<b>Layout</b>	Tessolve	Date	<b>Scale</b>	<b>Date</b> Thursday, January 16, 2014	<b>Sheet 1 of 6</b>

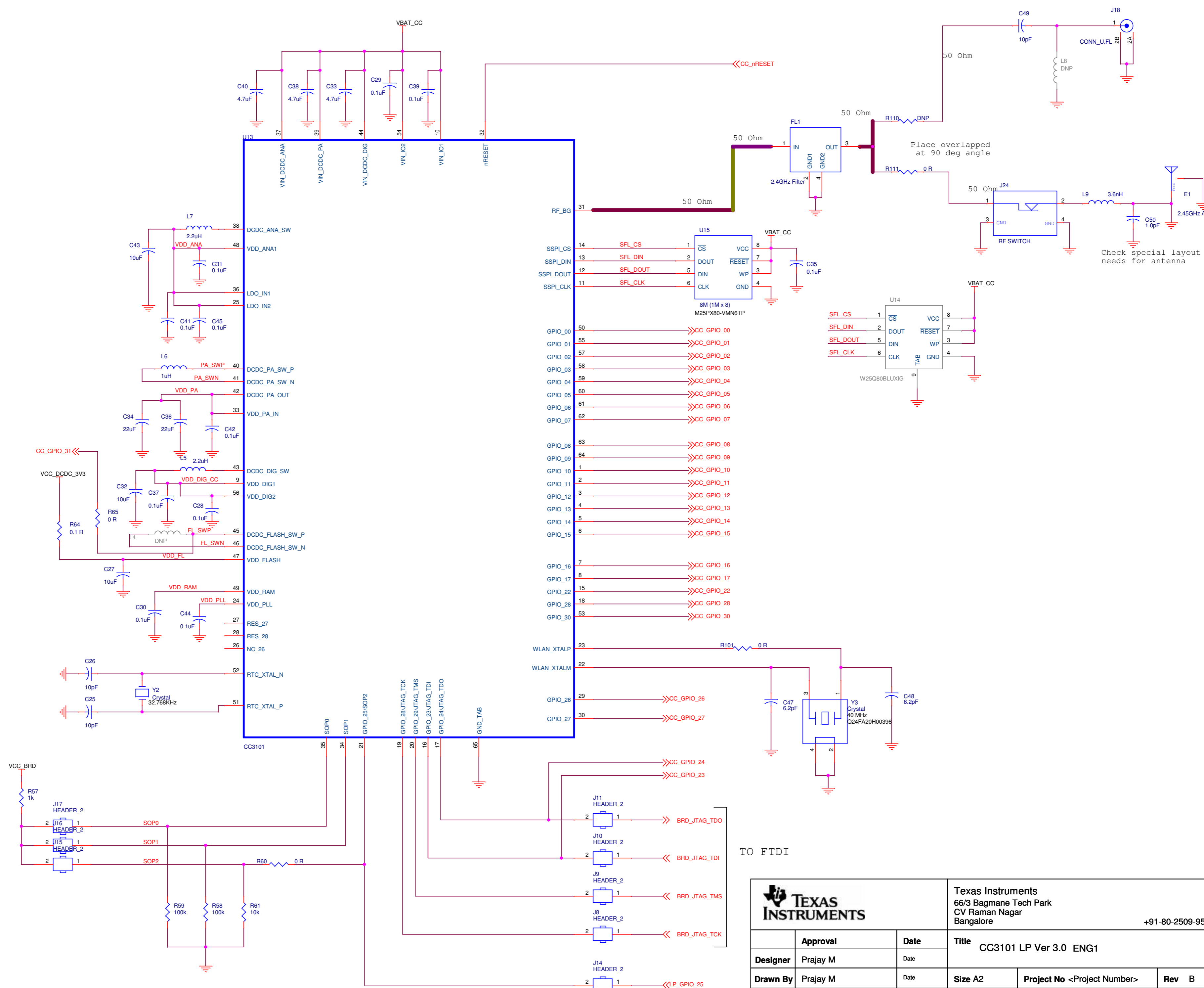

		Texas Instruments 66/3 Bagmane Tech Park CV Raman Nagar Bangalore			+91-80-2509-9599
		Title CC3101 LP Ver 3.0 ENG1			
Approval	Prajay M	Date	Date		
Designer	Prajay M	Date	Size A2	Project No <Project Number>	Rev B
Drawn By	Prajay M	Date	Scale	Date Thursday, January 16, 2014	Sheet 2 of 6
Layout	Tessolve	Date			

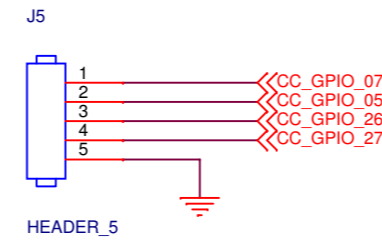
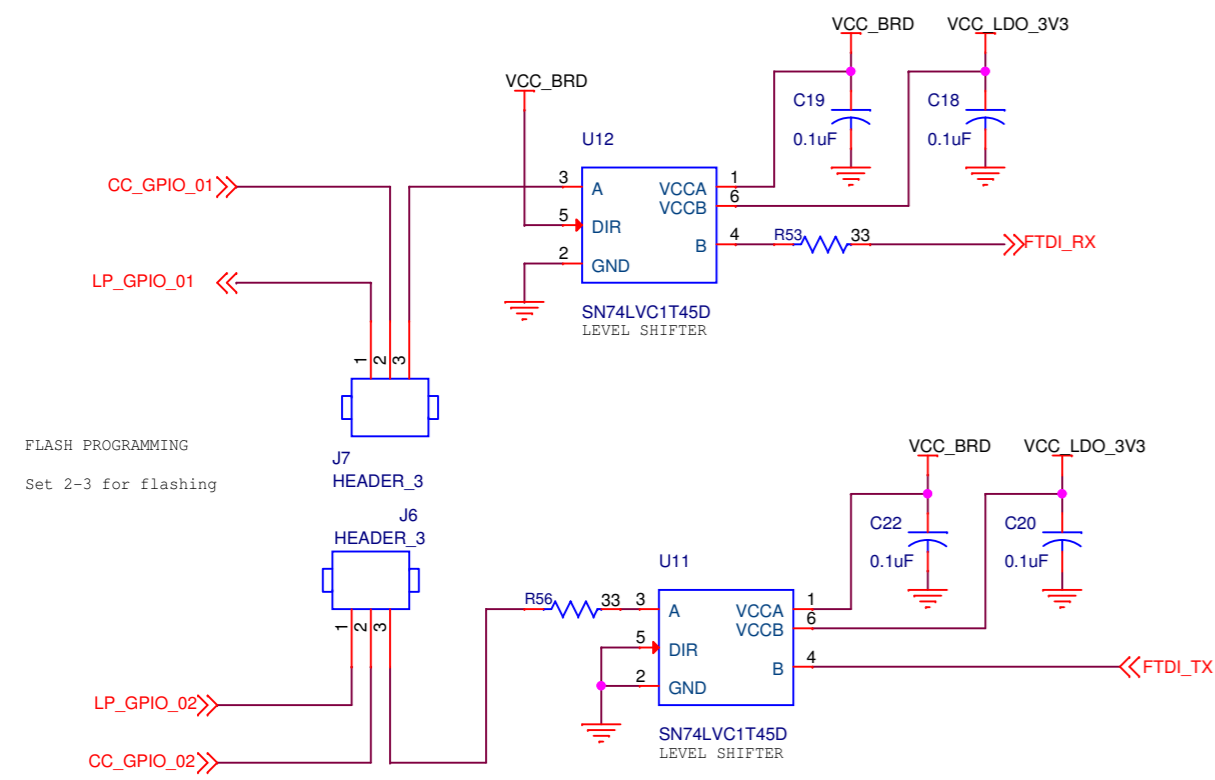
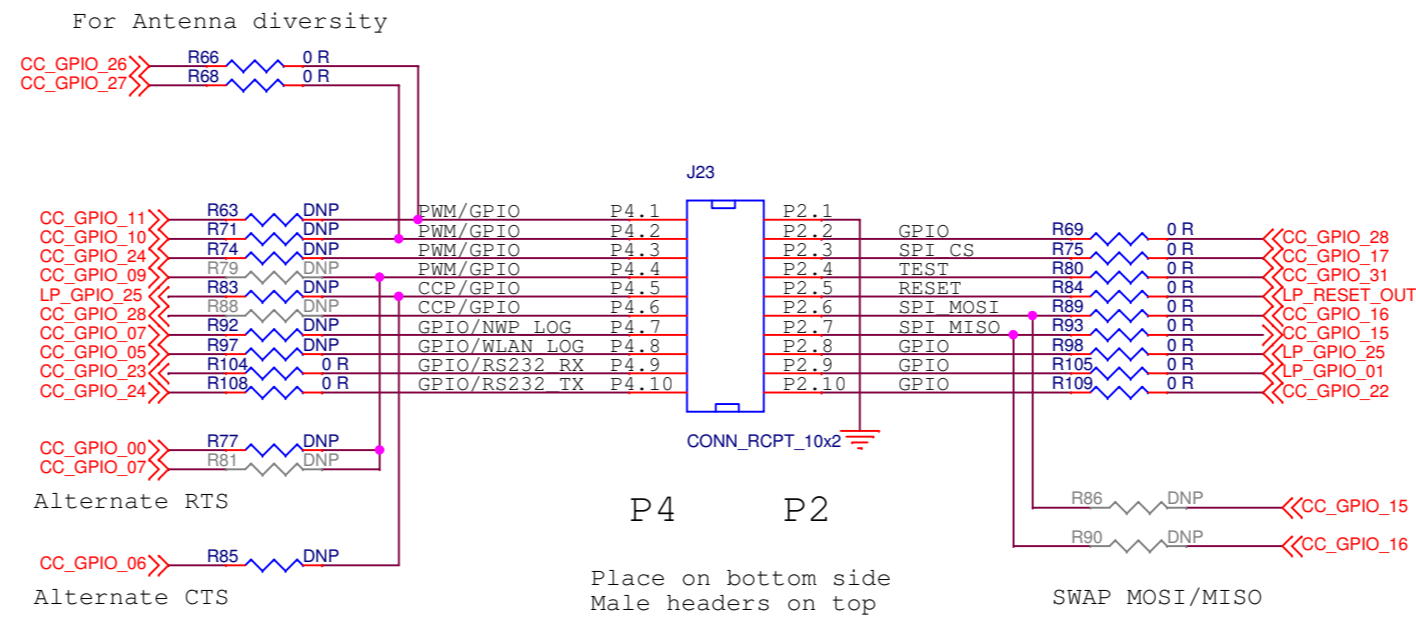
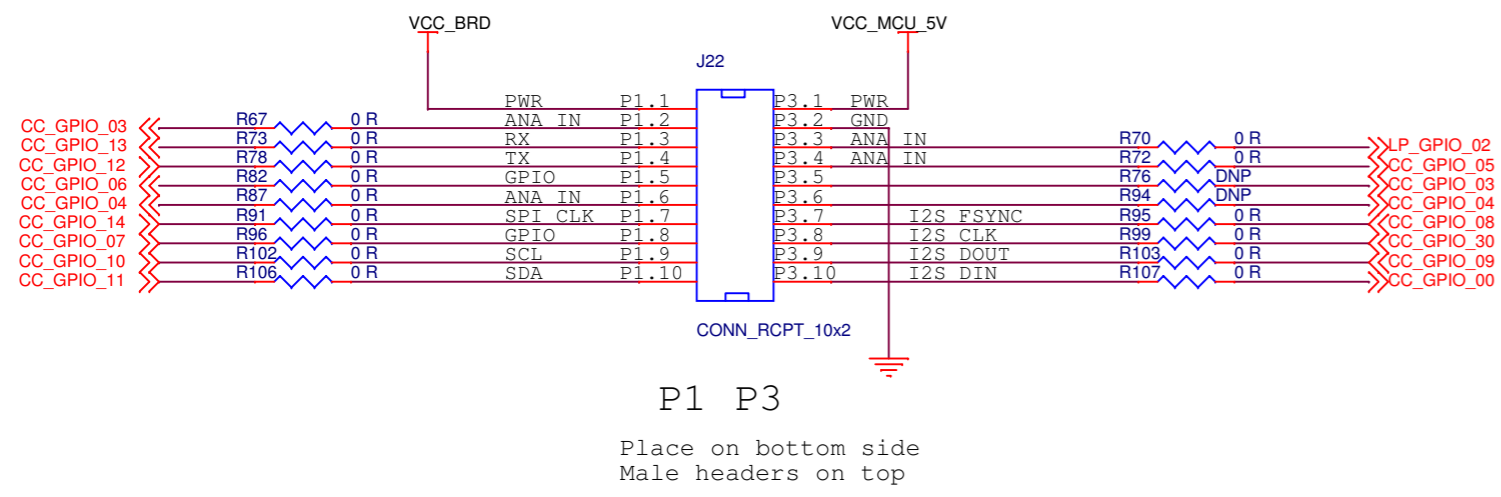

		Texas Instruments 66/3 Bagmane Tech Park CV Raman Nagar Bangalore +91-80-2509-9599			
		<b>Approval</b> Date	<b>Date</b> Date	<b>Title</b> CC3101 LP Ver 3.0 ENG1	
<b>Designer</b> Prajay M	<b>Approval</b> Date	<b>Date</b> Date	<b>Size</b> A2	<b>Project No</b> <Project Number>	<b>Rev</b> B
<b>Drawn By</b> Prajay M	<b>Approval</b> Date	<b>Date</b> Date	<b>Scale</b>	<b>Date</b> Thursday, January 16, 2014	<b>Sheet 3 of 6</b>
<b>Layout</b> Tessolve	<b>Approval</b> Date	<b>Date</b> Date	<b>Scale</b>	<b>Date</b> Thursday, January 16, 2014	<b>Sheet 3 of 6</b>

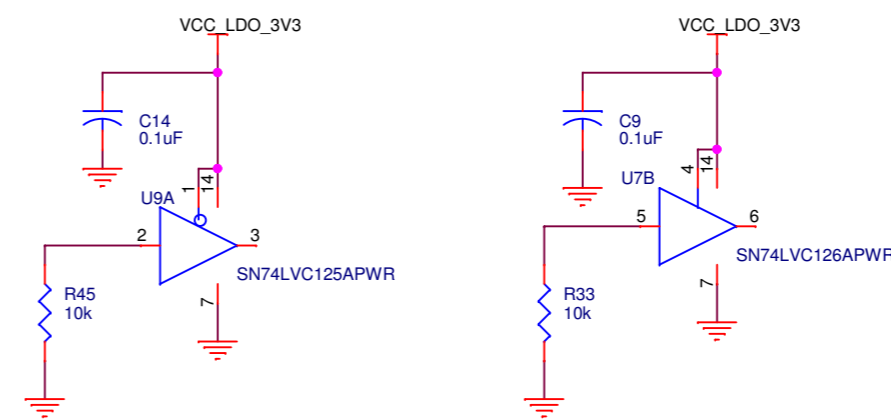
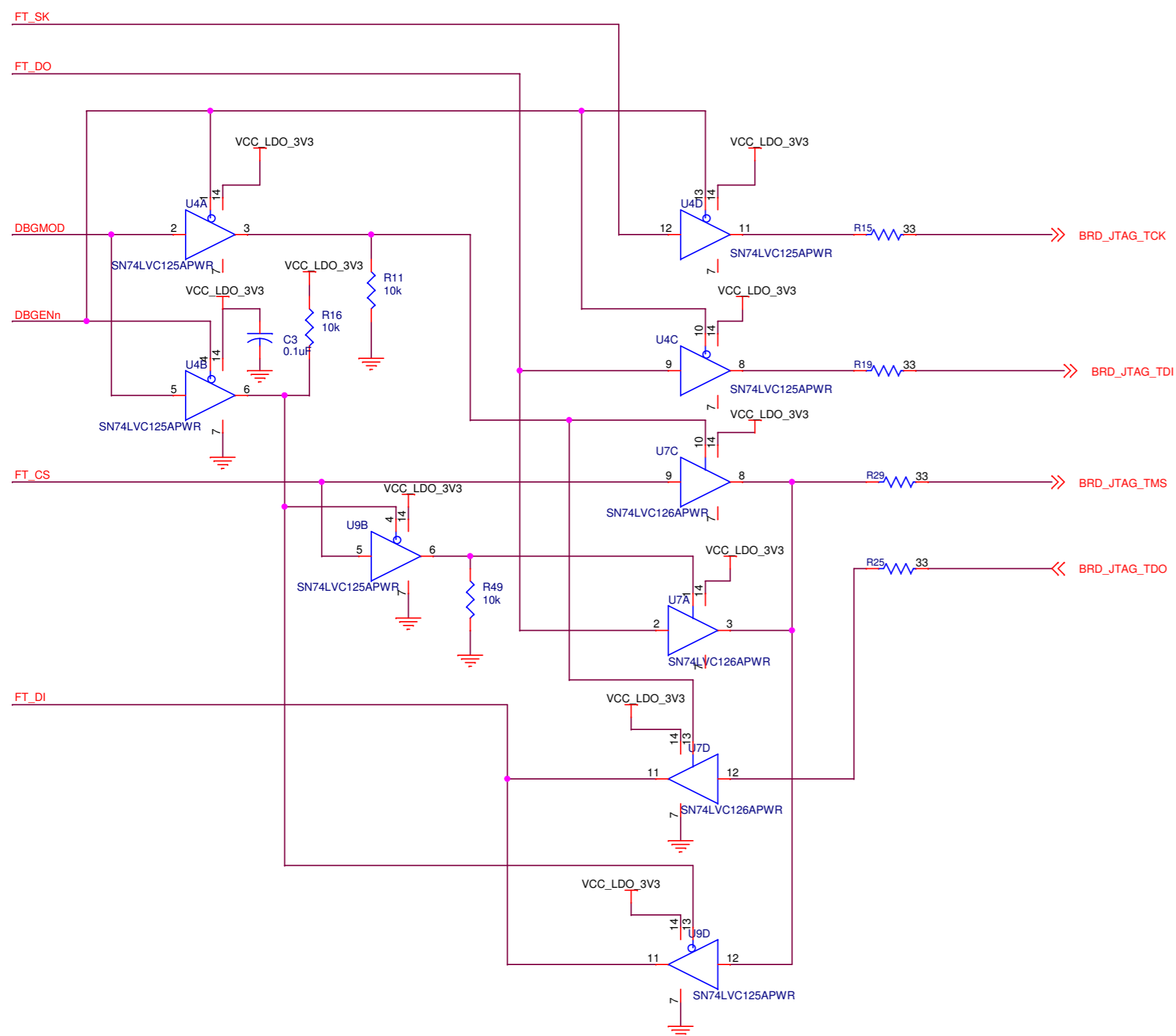
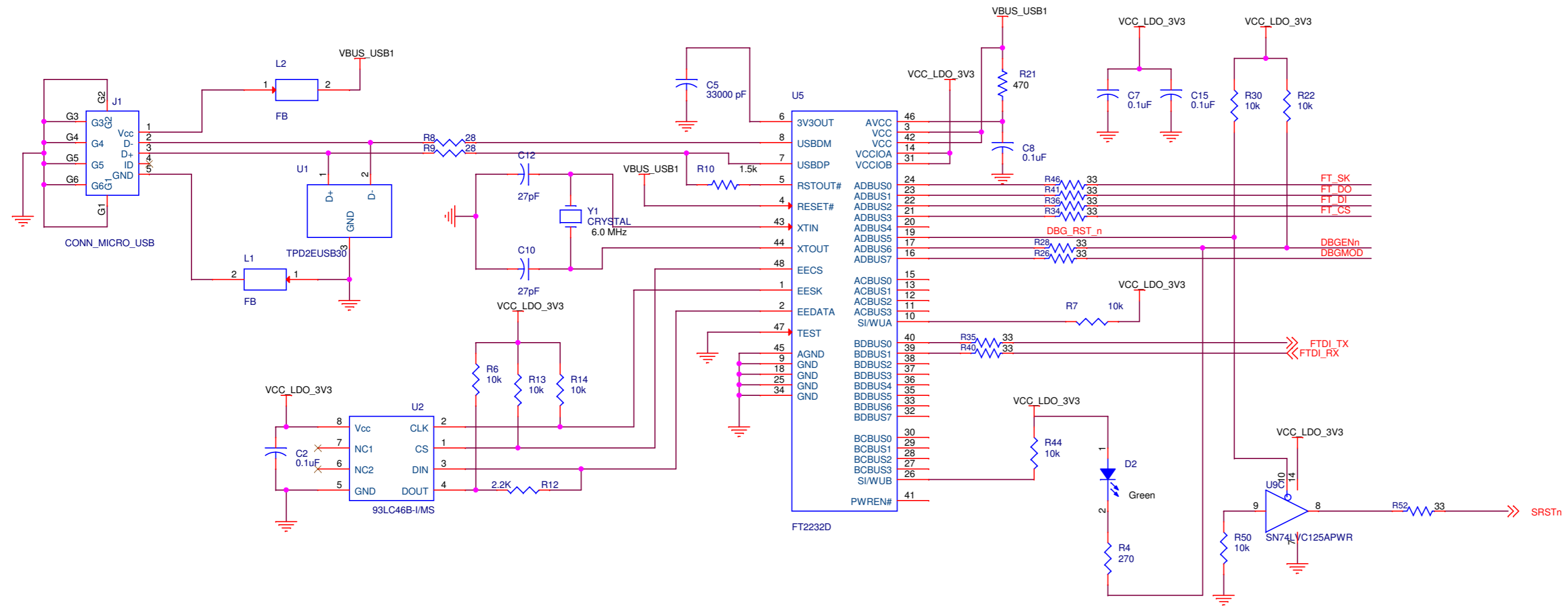

			Texas Instruments 66/3 Bagmane Tech Park CV Raman Nagar Bangalore			+91-80-2509-9599
			<b>Title</b> CC3101 LP Ver 3.0 ENG1			
<b>Approval</b>	Prajay M	<b>Date</b>	Date	<b>Size</b> A2	<b>Project No</b> <Project Number>	<b>Rev</b> B
<b>Designer</b>	Prajay M	<b>Date</b>	Date	<b>Scale</b>	<b>Date</b> Thursday, January 16, 2014	<b>Sheet</b> 4 of 6
<b>Drawn By</b>	Tessolve	<b>Date</b>	Date			

Temp Sensor

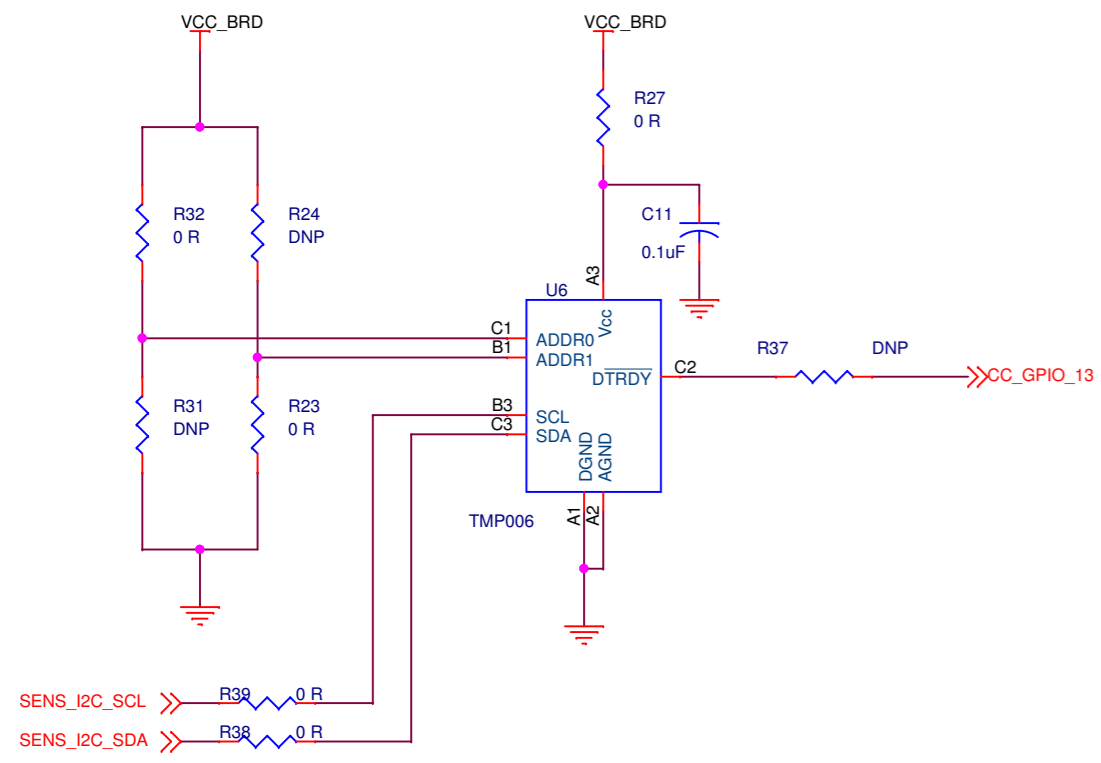

Accelerometer

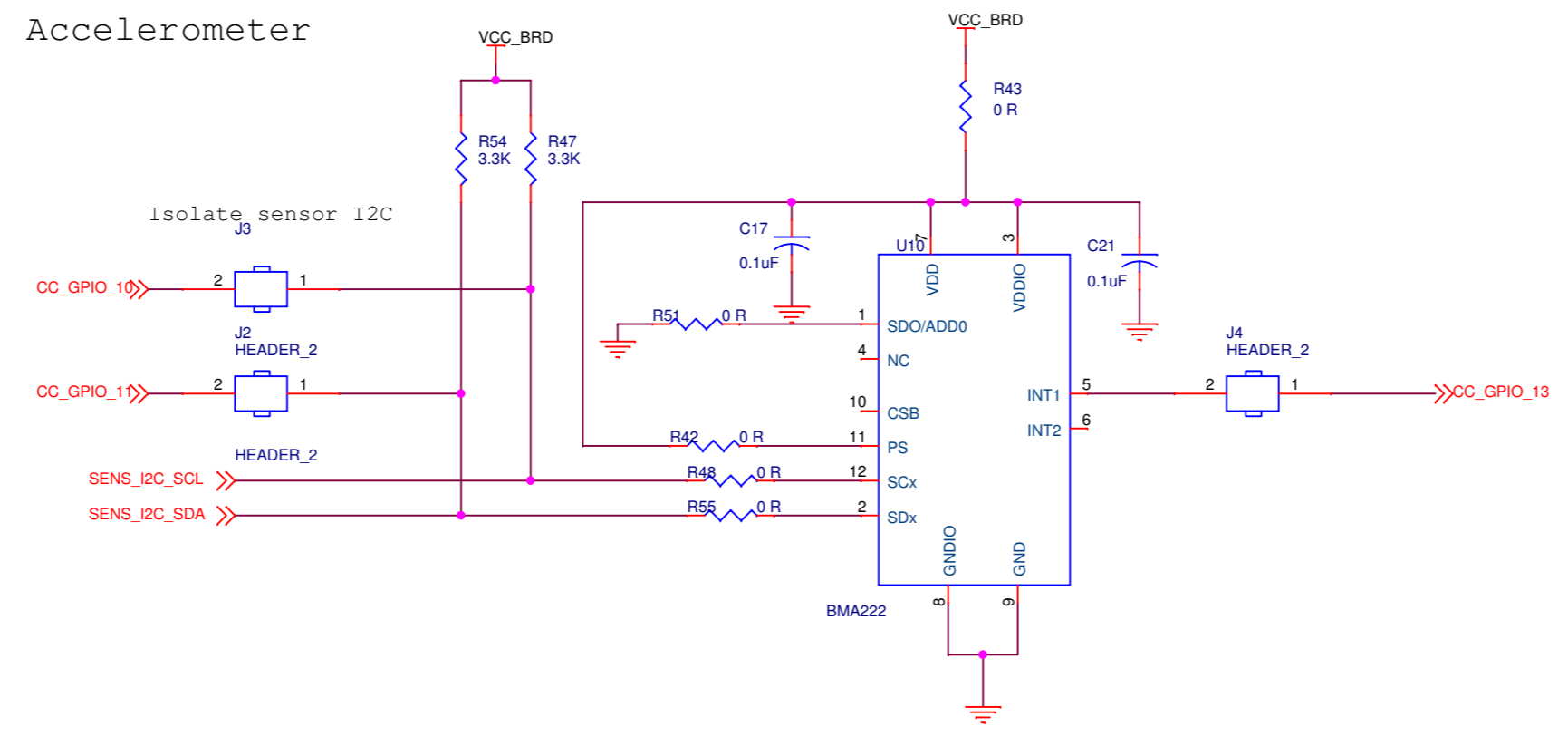

SWITCHES & RESET

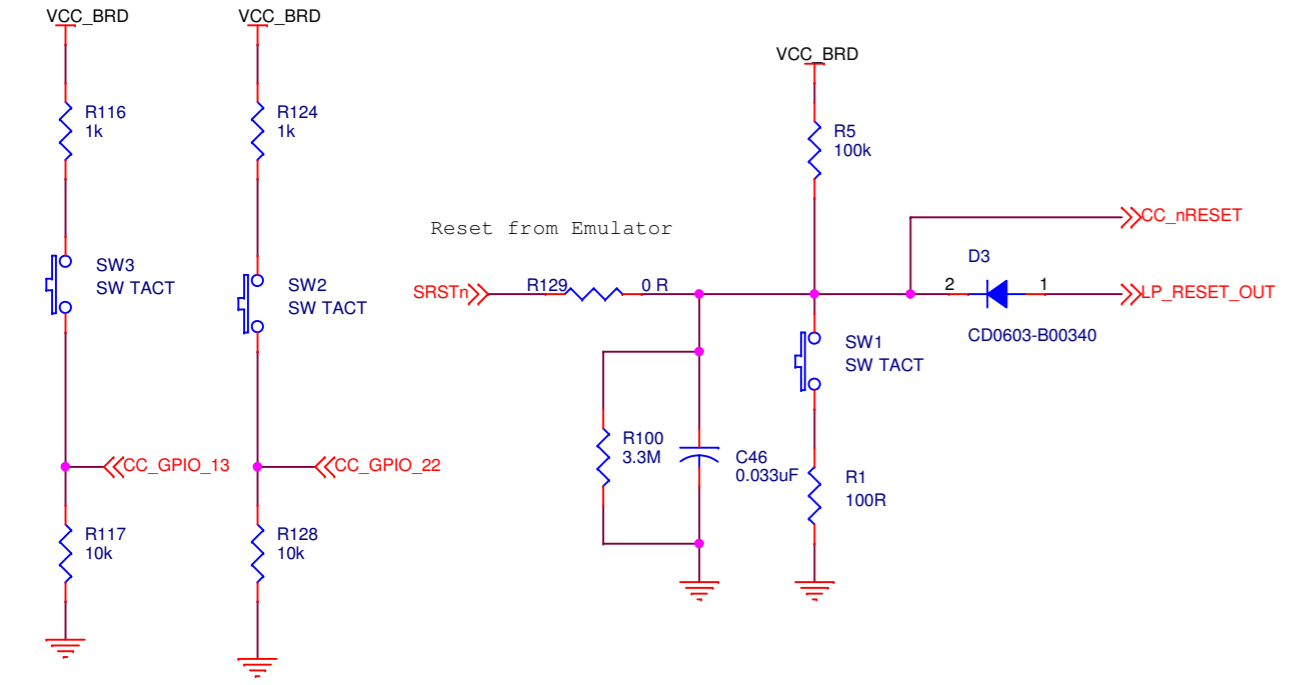

LED Indicators

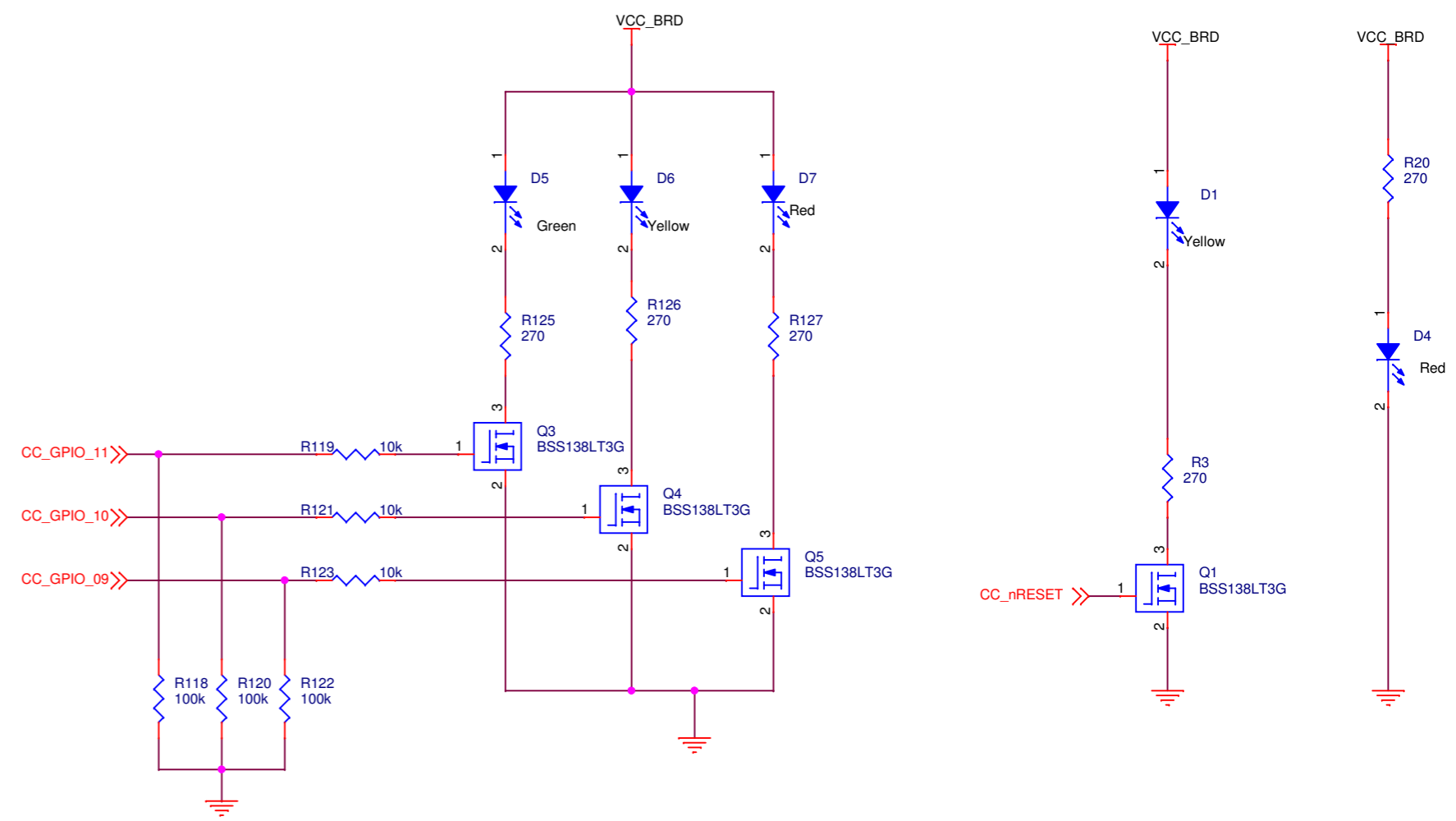

POWER MANAGEMENT

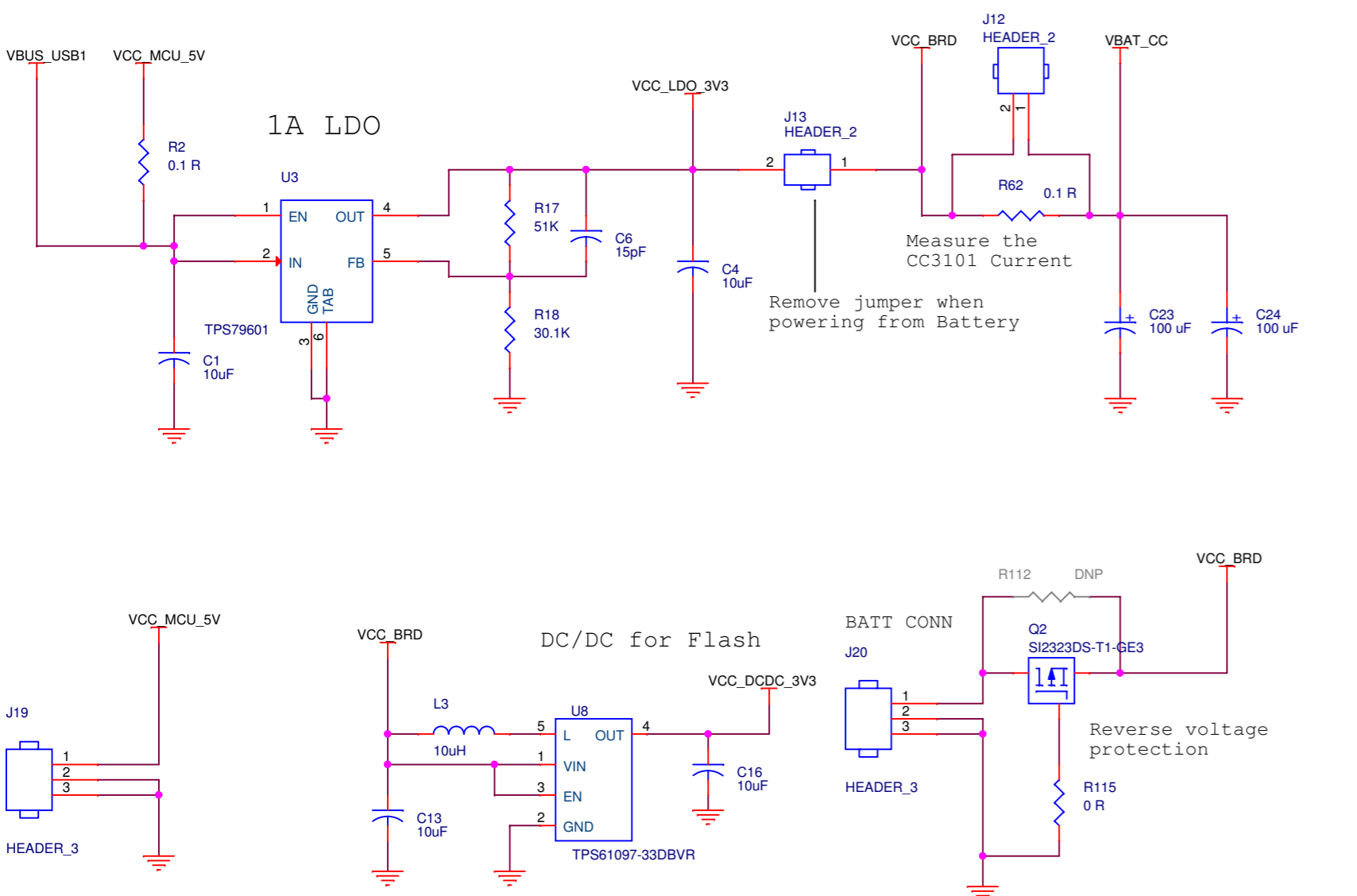

		Texas Instruments 66/3 Bagmane Tech Park CV Raman Nagar Bangalore		+91-80-2509-9599	
		Title CC3101 LP Ver 3.0 ENG1			
Approval	Prajay M	Date		Size A2	Project No <Project Number>
Designer	Prajay M	Date		Scale	Rev B
Drawn By	Prajay M	Date		Date	Thursday, January 16, 2014
Layout	Tessolve	Date		Sheet 5 of 6	