

**CFR 47 FCC PART 15 SUBPART C**

**TEST REPORT**

*For*

**Indoor Wi-Fi IP Plug In 1080p Deterrence Camera with 2-Way Audio – White**

**MODEL NUMBER: WCM-FWIP2-I**

**Trademark: Night Owl**

**REPORT NUMBER: E04A23050032F00101**

**ISSUE DATE: May. 18, 2023**

**FCC ID: Z63-FWIP2-I**

*Prepared for*

**SHENZHEN AONI ELECTRONIC CO.,LTD.**

**No.5,Bldg., Honghui Industrial Park, 2nd Liuxian Road, Xin' An streets, Bao' an  
District, Shenzhen, P.R.china**

*Prepared by*

**Guangdong Global Testing Technology Co., Ltd.**

**Room 101-105, 203-210, Building 1, No.2, Keji 8 Road, Songshan Lake  
Park, Dongguan city, Guangdong, People' s Republic of China, 523808**

**This report shall not be reproduced, except in full, without the written approval of  
Guangdong Global Testing Technology Co., Ltd.**

Revision History

<u>Rev.</u>	<u>Issue Date</u>	<u>Revisions</u>	<u>Revised By</u>
<u>V0</u>	<u>May 18, 2023</u>	<u>Initial Issue</u>	<u>Win</u>

### Summary of Test Results

Summary of Test Results			
Test Item	Clause	Limit/Requirement	Result
Antenna Requirement	N/A	FCC Part 15.203/15.247 (c)	Pass
AC Power Line Conducted Emission	ANSI C63.10-2013, Clause 6.2	FCC Part 15.207	Pass
Conducted Output Power	ANSI C63.10-2013, Clause 11.9.1.3	FCC Part 15.247 (b)(3)	Pass
6dB Bandwidth and 99% Occupied Bandwidth	ANSI C63.10-2013, Clause 11.8.1	FCC Part 15.247 (a)(2)	Pass
Power Spectral Density	ANSI C63.10-2013, Clause 11.10.2	FCC Part 15.247 (e)	Pass
Conducted Band edge and spurious emission	ANSI C63.10-2013, Clause 11.11	FCC Part 15.247(d)	Pass
Radiated Band edge and Spurious Emission	ANSI C63.10-2013, Clause 11.11 & Clause 11.12	FCC Part 15.205/15.209	Pass
Duty Cycle	ANSI C63.10-2013, Clause 11.6	None; for reporting purposes only.	Pass

\*The measurement result for the sample received is <Pass> according to <CFR 47 FCC PART 15 SUBPART C(DTS)> when <Accuracy Method> decision rule is applied.

## CONTENTS

<b>1.</b>	<b>ATTESTATION OF TEST RESULTS.....</b>	<b>5</b>
<b>2.</b>	<b>TEST METHODOLOGY.....</b>	<b>6</b>
<b>3.</b>	<b>FACILITIES AND ACCREDITATION.....</b>	<b>6</b>
<b>4.</b>	<b>CALIBRATION AND UNCERTAINTY .....</b>	<b>7</b>
4.1.	<i>MEASURING INSTRUMENT CALIBRATION .....</i>	<i>7</i>
4.2.	<i>MEASUREMENT UNCERTAINTY.....</i>	<i>7</i>
<b>5.</b>	<b>EQUIPMENT UNDER TEST .....</b>	<b>8</b>
5.1.	<i>DESCRIPTION OF EUT .....</i>	<i>8</i>
5.2.	<i>CHANNEL LIST .....</i>	<i>8</i>
5.3.	<i>MAXIMUM AVERAGE EIRP .....</i>	<i>9</i>
5.4.	<i>TEST CHANNEL CONFIGURATION.....</i>	<i>9</i>
5.5.	<i>THE WORSE CASE POWER SETTING PARAMETER.....</i>	<i>9</i>
5.6.	<i>DESCRIPTION OF AVAILABLE ANTENNAS .....</i>	<i>10</i>
5.7.	<i>SUPPORT UNITS FOR SYSTEM TEST.....</i>	<i>10</i>
5.8.	<i>SETUP DIAGRAM .....</i>	<i>11</i>
<b>6.</b>	<b>MEASURING EQUIPMENT AND SOFTWARE USED.....</b>	<b>12</b>
<b>7.</b>	<b>ANTENNA PORT TEST RESULTS .....</b>	<b>14</b>
7.1.	<i>Conducted Output Power.....</i>	<i>14</i>
7.2.	<i>6dB Bandwidth.....</i>	<i>15</i>
7.3.	<i>Power Spectral Density.....</i>	<i>16</i>
7.4.	<i>Conducted Band edge and spurious emission .....</i>	<i>17</i>
7.5.	<i>Duty Cycle .....</i>	<i>19</i>
<b>8.</b>	<b>RADIATED TEST RESULTS.....</b>	<b>20</b>
<b>9.</b>	<b>ANTENNA REQUIREMENT .....</b>	<b>33</b>
<b>10.</b>	<b>AC POWER LINE CONDUCTED EMISSION .....</b>	<b>34</b>
<b>11.</b>	<b>ST DATA .....</b>	<b>37</b>
	<b>APPENDIX: PHOTOGRAPHS OF TEST CONFIGURATION .....</b>	<b>38</b>
	<b>APPENDIX: PHOTOGRAPHS OF THE EUT .....</b>	<b>40</b>

## 1. ATTESTATION OF TEST RESULTS

### Applicant Information

Company Name: SHENZHEN AONI ELECTRONIC CO.,LTD.  
 Address: No.5,Bldg., Honghui Industrial Park, 2nd Liuxian Road, Xin' An streets, Bao' an District, Shenzhen, P.R.china

### Manufacturer Information

Company Name: Zhongshan KMETV Technology Co.,Ltd.  
 Address: 2F, Building A, No.45, Industrial Avenue Middle, Xiaolan Town, Zhongshan City, China

### EUT Information

EUT Name: Indoor Wi-Fi IP Plug In 1080p Deterrence Camera with 2-Way Audio – White  
 Model: WCM-FWIP2-I  
 Series Model: CAM-FWIP2-IN, CAM-2PK-FWIP2-IN, 1PK-WCM-FWIP2-I-WA, 2PK-WCM-FWIP2-I-WA, WCM-FWIP2-I-WA, WCM-FWIP2-I-CN13  
 Sample Received Date: May. 10, 2023  
 Sample Status: Normal  
 Sample ID: A23050032 006  
 Date of Tested: May. 10, 2023 to May. 18, 2023

APPLICABLE STANDARDS	
STANDARD	TEST RESULTS
CFR 47 FCC PART 15 SUBPART C	Pass

Prepared By:

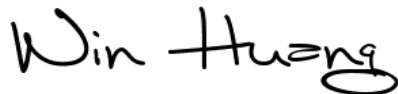

Win Huang  
 Project Engineer

Checked By:



Alan He  
 Project Engineer

Approved By:



Shawn Wen  
 Laboratory Supervisor

## 2. TEST METHODOLOGY

All tests were performed in accordance with the standard CFR 47 FCC PART 15 SUBPART C(DTS), DD

## 3. FACILITIES AND ACCREDITATION

Accreditation Certificate	<p><b>A2LA (Certificate No.: 6947.01)</b> Guangdong Global Testing Technology Co., Ltd. has been assessed and proved to be in compliance with A2LA.</p> <p><b>FCC (FCC Designation No.: CN1343)</b> Guangdong Global Testing Technology Co., Ltd. has been recognized to perform compliance testing on equipment subject to Supplier's Declaration of Conformity (SDoC) and Certification rules</p> <p><b>ISED (Company No.: 30714)</b> Guangdong Global Testing Technology Co., Ltd. has been registered and fully described in a report filed with ISED. The Company Number is 30714 and the test lab Conformity Assessment Body Identifier (CABID) is CN0148.</p>
---------------------------	--

Note: All tests measurement facilities use to collect the measurement data are located at Room 101-105, 203-210, Building 1, No.2, Keji 8 Road, Songshan Lake Park, Dongguan city, Guangdong, People's Republic of China, 523808

## 4. CALIBRATION AND UNCERTAINTY

### 4.1. MEASURING INSTRUMENT CALIBRATION

The measuring equipment utilized to perform the tests documented in this report has been calibrated in accordance with the manufacturer's recommendations and is traceable to recognized national standards.

### 4.2. MEASUREMENT UNCERTAINTY

Where relevant, the following measurement uncertainty levels have been estimated for tests performed on the apparatus:

Test Item	Measurement Frequency Range	K	U(dB)
AC Power Line Conducted Emission	0.009 MHz ~ 0.15 MHz	2	4.00
	0.15 MHz ~ 30 MHz	2	3.62
Radiated Band edge and Spurious Emission	9kHz ~ 30MHz	2	2.20
	30 MHz ~ 1 GHz	2	3.16
	1 GHz ~ 18 GHz	2	5.64
	18 GHz ~ 26.5 GHz	2	5.54
Conducted Output Power	/	2	0.73
6dB Bandwidth and 99% Occupied Bandwidth	/	2	9.2ppm
Power Spectral Density	/	2	1.84
Conducted Band edge and spurious emission	9kHz ~ 30MHz	2	0.95
	30 MHz ~ 1 GHz	2	1.49
	1 GHz ~ 18 GHz	2	1.75
	18 GHz ~ 26.5 GHz	2	2.06

Note: This uncertainty represents an expanded uncertainty expressed at approximately the 95% confidence level using a coverage factor of k=2.

## 5. EQUIPMENT UNDER TEST

### 5.1. DESCRIPTION OF EUT

EUT Name		Indoor Wi-Fi IP Plug In 1080p Deterrence Camera with 2-Way Audio – White
Model		WCM-FWIP2-I
Series Model		CAM-FWIP2-IN, CAM-2PK-FWIP2-IN, 1PK-WCM-FWIP2-I-WA, 2PK-WCM-FWIP2-I-WA, WCM-FWIP2-I-WA, WCM-FWIP2-I-CN13
EUT Classification		Class B
Ratings		DC 5V 1000mA
Power Supply	DC	DC 5V 1000mA

Frequency Band:	2400 MHz to 2483.5 MHz
Frequency Range:	2412 MHz to 2462 MHz
Support Standards:	IEEE 802.11b, IEEE 802.11g, IEEE 802.11n-HT20, IEEE 802.11n-HT40
Type of Modulation:	IEEE 802.11b: DSSS(CCK, DQPSK, DBPSK) IEEE 802.11g/n: OFDM(64-QAM, 16-QAM, QPSK, BPSK)
Data Rate:	IEEE 802.11b: Up to 11 Mbps IEEE 802.11g: Up to 54 Mbps IEEE 802.11n: Up to MCS7
Number of Channels:	IEEE 802.11b/g/n-HT20: 11 IEEE 802.11n-HT40: 7
Maximum Peak Power:	IEEE 802.11b: 11.16 dBm IEEE 802.11g: 11.14 dBm IEEE 802.11n-HT20: 11.14 dBm IEEE 802.11n-HT40: 11.13 dBm
Antenna Type:	Integral Antenna
Antenna Gain:	2.29dBi
Normal Test Voltage:	5 Vdc

### 5.2. CHANNEL LIST

Channel List for 802.11b/g/n (20 MHz)							
Channel	Frequency (MHz)	Channel	Frequency (MHz)	Channel	Frequency (MHz)	Channel	Frequency (MHz)
1	2412	4	2427	7	2442	10	2457
2	2417	5	2432	8	2447	11	2462
3	2422	6	2437	9	2452	/	/

Channel List for 802.11n (40 MHz)							
Channel	Frequency (MHz)	Channel	Frequency (MHz)	Channel	Frequency (MHz)	Channel	Frequency (MHz)
3	2422	5	2432	7	2442	9	2452
4	2427	6	2437	8	2447	/	/



**5.3. MAXIMUM AVERAGE EIRP**

IEEE Std. 802.11	Frequency (MHz)	Channel Number	Maximum Conducted AVG Output Power (dBm)
b	2412 ~ 2462	1-11[11]	11.16
g	2412 ~ 2462	1-11[11]	11.14
n HT20	2412 ~ 2462	1-11[11]	11.13
n HT40	2422 ~ 2452	3-9[7]	11.13

**5.4. TEST CHANNEL CONFIGURATION**

IEEE Std. 802.11	Test Channel Number	Frequency
b	CH 1(Low Channel), CH 6(MID Channel), CH 11(High Channel)	2412 MHz, 2437 MHz, 2462 MHz
g	CH 1(Low Channel), CH 6(MID Channel), CH 11(High Channel)	2412 MHz, 2437 MHz, 2462 MHz
n HT20	CH 1(Low Channel), CH 6(MID Channel), CH 11(High Channel)	2412 MHz, 2437 MHz, 2462 MHz
n HT40	CH 3(Low Channel), CH 6(MID Channel), CH 9(High Channel)	2422 MHz, 2437 MHz, 2452 MHz

**5.5. THE WORSE CASE POWER SETTING PARAMETER**

The Worst Case Power Setting Parameter under 2400 ~ 2483.5MHz Band							
Test Software		SecureCRT.exe					
Modulation Mode	Transmit Antenna Number	Test Channel					
		NCB: 20MHz			NCB: 40MHz		
		CH 1	CH 6	CH 11	CH 3	CH 6	CH 9
802.11b	1	Default value	Default value	Default value			
802.11g	1	Default value	Default value	Default value			
802.11n HT20	1	Default value	Default value	Default value			
802.11n HT40	1				Default value	Default value	Default value

**WORST-CASE CONFIGURATIONS**

The EUT was tested in the following configuration(s):

Controlled in test mode using a software application on the EUT supplied by customer. The application was used to enable a continuous transmission and to select the mode, test channels, bandwidth, data rates as required.

Test channels referring to section 5.4.

Maximum power setting referring to section 5.5.

Worst-case data rates as provided by the client were:

802.11b mode: 1 Mbps  
 802.11g mode: 6 Mbps  
 802.11n HT20 mode: MCS0  
 802.11n HT40 mode: MCS0

## 5.6. DESCRIPTION OF AVAILABLE ANTENNAS

Antenna	Frequency (MHz)	Antenna Type	MAX Antenna Gain (dBi)
1	2412-2462	Integral	2.29

Test Mode	Transmit and Receive Mode	Description
IEEE 802.11b	<input checked="" type="checkbox"/> 1TX, 1RX	ANT 1 can be used as transmitting/receiving antenna.
IEEE 802.11g	<input checked="" type="checkbox"/> 1TX, 1RX	ANT 1 can be used as transmitting/receiving antenna.
IEEE 802.11n HT20	<input checked="" type="checkbox"/> 1TX, 1RX	ANT 1 can be used as transmitting/receiving antenna.
IEEE 802.11n HT40	<input checked="" type="checkbox"/> 1TX, 1RX	ANT 1 can be used as transmitting/receiving antenna.

Note: The value of the antenna gain was declared by customer.

## 5.7. SUPPORT UNITS FOR SYSTEM TEST

Item	Equipment	Equipment	Model No.	Note
1	Indoor Wi-Fi IP Plug In 1080p Deterrence Camera with 2-Way Audio – White	AlfredCamera	WCM-FWIP2-I	EUT
2	Adapter	KEYU	MODEL: BS05A-0501000US INPUT: 100-240V~50/60Hz 0.25A Max OUTPUT: 5V 1000mA	Support EUT
3	Adapter	KEYU	MODEL: KA06E-050100US INPUT: 100-240V~50/60Hz 0.25A Max OUTPUT: 5V 1000mA	Support EUT
4	PC	Lenovo	T14	Auxiliary equipment

## 5.8. SETUP DIAGRAM

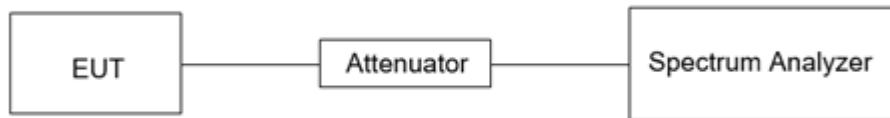
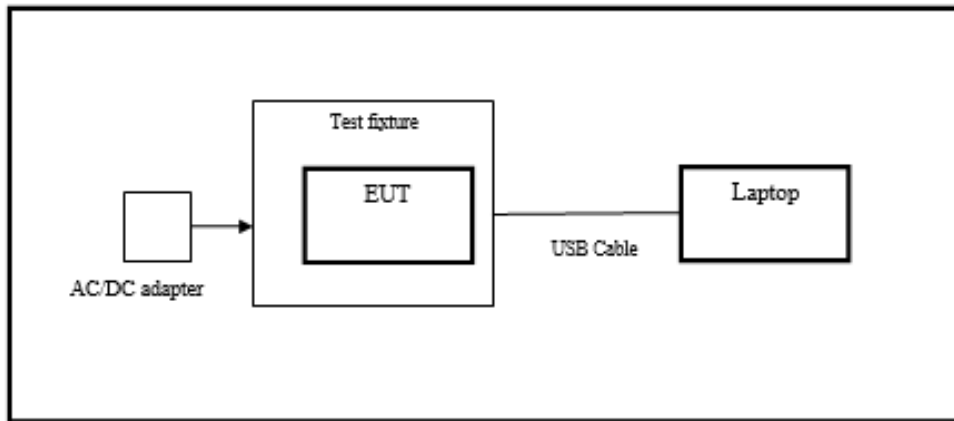

## 6. MEASURING EQUIPMENT AND SOFTWARE USED

Test Equipment of Conducted RF					
Equipment	Manufacturer	Model No.	Serial No.	Last Cal.	Due Date
Spectrum Analyzer	Rohde & Schwarz	FSV40	102257	2022/10/08	2023/10/07
EXG Analog Signal Generator	KEYSIGHT	N5173B	MY61253075	2022/10/08	2023/10/07
Vector Signal Generator	Rohde & Schwarz	SMM100A	101899	2023/03/16	2024/03/15
RF Control box	MWRF-test	MW100-RFCB	MW220926GTG	2022/10/08	2023/10/07
Wideband Radio Communication Tester	Rohde & Schwarz	CMW270	102792	2023/03/16	2024/03/15
Wideband Radio Communication Tester	Rohde & Schwarz	CMW500	103235	2022/10/08	2023/10/07
temperature humidity chamber	Espec	SH-241	SH-241-2014	2022/10/08	2023/10/07
RF Test Software	MWRF-test	MTS8310E (Ver. V2/0)	N/A	N/A	N/A
Test Equipment of Radiated emissions below 1GHz					
Equipment	Manufacturer	Model No.	Serial No.	Last Cal.	Due Date
3m Semi-anechoic Chamber	ETS	9m*6m*6m	Q2146	2022/08/30	2025/08/29
EMI Test Receiver	Rohde & Schwarz	ESCI3	101409	2022/10/08	2023/10/07
Pre-Amplifier	HzEMC	HPA-9K0130	HYP A21001	2022/10/29	2023/10/28
Biconilog Antenna	Schwarzbeck	VULB 9168	01315	2022/10/10	2025/10/09
Biconilog Antenna	ETS	3142E	00243646	2022/03/23	2025/03/22
Loop Antenna	ETS	6502	243668	2022/03/30	2025/03/29
Test Software	Farad	EZ-EMC (Ver.FA-03A2 RE)	N/A	N/A	N/A
Test Equipment of Radiated emissions above 1GHz					
Equipment	Manufacturer	Model No.	Serial No.	Last Cal.	Due Date
3m Semi-anechoic Chamber	ETS	9m*6m*6m	Q2149	2022/08/30	2025/08/29
Spectrum Analyzer	Rohde & Schwarz	FSV40	101413	2022/10/08	2023/10/07
Pre-Amplifier	A-INFO	HPA-1G1850	HYP A21003	2022/10/29	2023/10/28
Horn antenna	A-INFO	3117	246069	2022/03/11	2023/03/10
Pre-Amplifier	ZKJC	HPA-184057	HYP A21004	2022/10/29	2023/10/28
Horn antenna	ZKJC	3116C	246265	2022/03/29	2023/03/28
Test Software	Farad	EZ-EMC (Ver.FA-03A2 RE+)	N/A	N/A	N/A
Test Equipment of Conducted emissions					
Equipment	Manufacturer	Model No.	Serial No.	Last Cal.	Due Date

---

Shielded Room	CHENG YU	8m*5m*4m	N/A	2022/10/29	2025/10/28
EMI Test Receiver	Rohde & Schwarz	ESR3	102647	2022/12/03	2023/12/02
LISN/AMN	Rohde & Schwarz	ENV216	102843	2022/10/08	2023/10/07
NNLK 8129 RC	Schwarzbeck	NNLK 8129 RC	5046	2023/03/30	2024/03/29
Test Software	Farad	EZ-EMC (Ver. EMC-con-3A1 1+)	N/A	N/A	N/A

## 7. ANTENNA PORT TEST RESULTS

### 7.1. CONDUCTED OUTPUT POWER

#### LIMITS

CFR 47 FCC Part15 (15.247) Subpart C ISED RSS-247 ISSUE 2			
Section	Test Item	Limit	Frequency Range (MHz)
CFR 47 FCC 15.247(b)(3)	Peak Conduct Output Power	1 watt or 30 dBm	2400-2483.5

#### TEST PROCEDURE

Connect the EUT to a low loss RF cable from the antenna port to the spectrum analyzer (video bandwidth is greater than the occupied bandwidth).

Measure peak emission level, the indicated level is the peak output power, after any corrections for external attenuators and cables.

#### TEST ENVIRONMENT

Temperature	24°C	Relative Humidity	55%
Atmosphere Pressure	101kPa		

#### TEST RESULTS

Please refer to section "Test Data" - Appendix A

## 7.2. 6DB BANDWIDTH

### LIMITS

CFR 47 FCC Part15 (15.247) Subpart C			
Section	Test Item	Limit	Frequency Range (MHz)
CFR 47 FCC 15.247(a)(2)	6 dB Bandwidth	≥ 500 kHz	2400-2483.5

### TEST PROCEDURE

Refer to ANSI C63.10-2013 clause 11.8 for DTS bandwidth and clause 6.9 for Occupied Bandwidth.

Connect the EUT to the spectrum analyser and use the following settings:

Center Frequency	The center frequency of the channel under test
Frequency Span	For 6 dB Bandwidth: Enough to capture all products of the modulation carrier emission
Detector	Peak
RBW	For 6 dB Bandwidth: 100 kHz
VBW	For 6 dB Bandwidth: ≥3 x RBW
Trace	Max hold
Sweep	Auto couple

a) Use the 99 % power bandwidth function of the instrument, allow the trace to stabilize and report the measured bandwidth.

b) Allow the trace to stabilize and measure the maximum width of the emission that is constrained by the frequencies associated with the two outermost amplitude points (upper and lower frequencies) that are attenuated by 6 dB relative to the maximum level measured in the fundamental emission.

### TEST ENVIRONMENT

Temperature	24°C	Relative Humidity	55%
Atmosphere Pressure	101kPa		

### TEST RESULTS

Please refer to section "Test Data" - Appendix A

### 7.3. POWER SPECTRAL DENSITY

#### LIMITS

CFR 47 FCC Part15 (15.247) Subpart C			
Section	Test Item	Limit	Frequency Range (MHz)
CFR 47 FCC §15.247 (e)	Power Spectral Density	8 dBm in any 3 kHz band	2400-2483.5

#### TEST PROCEDURE

Refer to ANSI C63.10-2013 clause 11.10.

Connect the EUT to the spectrum analyser and use the following settings:

Center Frequency	The center frequency of the channel under test
Detector	PEAK
RBW	$3 \text{ kHz} \leq \text{RBW} \leq 100 \text{ kHz}$
VBW	$\geq 3 \times \text{RBW}$
Span	1.5 x DTS bandwidth
Trace	Max hold
Sweep time	Auto couple

Allow trace to fully stabilize and use the peak marker function to determine the maximum amplitude level within the RBW.

If measured value exceeds limit, reduce RBW (no less than 3 kHz) and repeat.

#### TEST ENVIRONMENT

Temperature	24°C	Relative Humidity	55%
Atmosphere Pressure	101kPa		

#### TEST RESULTS

Please refer to section "Test Data" - Appendix A



## 7.4. CONDUCTED BAND EDGE AND SPURIOUS EMISSION

### LIMITS

CFR 47 FCC Part15 (15.247) Subpart C		
Section	Test Item	Limit
CFR 47 FCC §15.247 (d)	Conducted Bandedge and Spurious Emissions	at least 20 dB below that in the 100 kHz bandwidth within the band that contains the highest level of the desired power

### TEST PROCEDURE

Refer to ANSI C63.10-2013 clause 11.11 and 11.13.

Connect the EUT to the spectrum analyser and use the following settings for reference level measurement:

Center Frequency	The center frequency of the channel under test
Detector	Peak
RBW	100 kHz
VBW	$\geq 3 \times \text{RBW}$
Span	1.5 x DTS bandwidth
Trace	Max hold
Sweep time	Auto couple.

Allow trace to fully stabilize and use the peak marker function to determine the maximum PSD level.

Change the settings for emission level measurement:

Span	Set the center frequency and span to encompass frequency range to be measured
Detector	Peak
RBW	100 kHz
VBW	$\geq 3 \times \text{RBW}$
measurement points	$\geq \text{span}/\text{RBW}$
Trace	Max hold
Sweep time	Auto couple.

Allow trace to fully stabilize and use the peak marker function to determine the maximum PSD level. Ensure that the amplitude of all unwanted emissions outside of the authorized frequency band (excluding restricted frequency bands) is attenuated by at least the minimum requirements specified in 11.11.

### TEST ENVIRONMENT

Temperature	24°C	Relative Humidity	55%
Atmosphere Pressure	101kPa		

**TEST RESULTS**

Please refer to section "Test Data" - Appendix A

## 7.5. DUTY CYCLE

### LIMITS

None; for reporting purposes only.

### TEST PROCEDURE

Refer to ANSI C63.10-2013 clause 11.6 Zero – Span Spectrum Analyzer method.

### TEST ENVIRONMENT

Temperature	24°C	Relative Humidity	55%
Atmosphere Pressure	101kPa		

### TEST RESULTS

Please refer to section "Test Data" - Appendix A

## 8. RADIATED TEST RESULTS

### LIMITS

Please refer to CFR 47 FCC §15.205 and §15.209.

Radiation Disturbance Test Limit for FCC (Class B) (9 kHz ~ 1 GHz)

Emissions radiated outside of the specified frequency bands above 30 MHz			
Frequency Range (MHz)	Field Strength Limit (uV/m) at 3 m	Field Strength Limit (dBuV/m) at 3 m	
		Quasi-Peak	
30 - 88	100	40	
88 - 216	150	43.5	
216 - 960	200	46	
Above 960	500	54	
Above 1000	500	Peak	Average
		74	54

FCC Emissions radiated outside of the specified frequency bands below 30 MHz		
Frequency (MHz)	Field strength (microvolts/meter)	Measurement distance (meters)
0.009-0.490	2400/F(kHz)	300
0.490-1.705	24000/F(kHz)	30
1.705-30.0	30	30

FCC Restricted bands of operation refer to FCC §15.205 (a):

MHz	MHz	MHz	GHz
0.090-0.110	16.42-16.423	399.9-410	4.5-5.15
<sup>1</sup> 0.495-0.505	16.69475-16.69525	608-614	5.35-5.46
2.1735-2.1905	16.80425-16.80475	960-1240	7.25-7.75
4.125-4.128	25.5-25.67	1300-1427	8.025-8.5
4.17725-4.17775	37.5-38.25	1435-1626.5	9.0-9.2
4.20725-4.20775	73-74.6	1645.5-1646.5	9.3-9.5
6.215-6.218	74.8-75.2	1660-1710	10.6-12.7
6.26775-6.26825	108-121.94	1718.8-1722.2	13.25-13.4
6.31175-6.31225	123-138	2200-2300	14.47-14.5
8.291-8.294	149.9-150.05	2310-2390	15.35-16.2
8.362-8.366	156.52475-156.52525	2483.5-2500	17.7-21.4
8.37625-8.38675	156.7-156.9	2690-2900	22.01-23.12
8.41425-8.41475	162.0125-167.17	3260-3267	23.6-24.0
12.29-12.293	167.72-173.2	3332-3339	31.2-31.8
12.51975-12.52025	240-285	3345.8-3358	36.43-36.5
12.57675-12.57725	322-335.4	3600-4400	( <sup>2</sup> )
13.36-13.41			

Note: <sup>1</sup>Until February 1, 1999, this restricted band shall be 0.490-0.510 MHz.

<sup>2</sup>Above 38.6c**TEST PROCEDURE**

Below 30 MHz

The setting of the spectrum analyser

RBW	200 Hz (From 9 kHz to 0.15 MHz)/ 9 kHz (From 0.15 MHz to 30 MHz)
VBW	200 Hz (From 9 kHz to 0.15 MHz)/ 9 kHz (From 0.15 MHz to 30 MHz)
Sweep	Auto

1. The testing follows the guidelines in ANSI C63.10-2013 clause 6.4.
2. The EUT was arranged to its worst case and then turntable (from 0 degree to 360 degrees) to find the maximum reading. A pre-amp and a high pass filter are used for the test in order to get better signal level. Both Horizontal, Face-on and Face-off polarizations of the antenna are set to make the measurement.
3. The EUT was placed on a turntable with 80 cm above ground.
4. The EUT was set 3 meters from the interference receiving antenna, which was mounted on the top of a 1 m height antenna tower.
5. The radiated emission limits are based on measurements employing a CISPR quasi-peak detector except for the frequency bands 9-90 kHz, 110-490 kHz and above 1000 MHz Radiated emission limits in these three bands are based on measurements employing an average detector.
6. For measurement below 1 GHz, the initial step in collecting conducted emission data is a spectrum analyzer peak detector mode pre-scanning the measurement frequency range. Significant peaks are then marked and then Quasi Peak and average detector mode re-measured. If the emission level of the EUT measured by the peak detector is 3 dB lower than the applicable limit, the peak emission level will be reported. Otherwise, the emission measurement will be repeated using the quasi-peak and average detector and reported.
7. Although these tests were performed other than open field site, adequate comparison measurements were confirmed against 30m open field site. Therefore sufficient tests were made to demonstrate that the alternative site produces results that correlate with the ones of tests made in an open field site based on KDB 414788.
8. The limits in CFR 47, Part 15, Subpart C, paragraph 15.209 (a), are identical to those in RSS-GEN Section 8.9, Table 6, since the measurements are performed in terms of magnetic field strength and converted to electric field strength levels (as reported in the table) using the free space impedance of 377Ω. For example, the measurement frequency X KHz resulted in a level of Y dBuV/m, which is equivalent to  $Y-51.5 = Z$  dBuA/m, which has the same margin, W dB, to the corresponding RSS-GEN Table 6 limit as it has to be 15.209(a) limit.

Below 1 GHz and above 30 MHz

The setting of the spectrum analyser

RBW	120 kHz
VBW	300 kHz
Sweep	Auto
Detector	Peak/QP

Trace	Max hold
-------	----------

1. The testing follows the guidelines in ANSI C63.10-2013 clause 6.5.
2. The EUT was arranged to its worst case and then tune the antenna tower (from 1 m to 4 m) and turntable (from 0 degree to 360 degrees) to find the maximum reading. A pre-amp and a high pass filter are used for the test in order to get better signal level. Both horizontal and vertical polarizations of the antenna are set to make the measurement.
3. The EUT was placed on a turntable with 80 cm above ground.
4. The EUT was set 3 meters from the interference receiving antenna, which was mounted on the top of a variable height antenna tower.
5. For measurement below 1 GHz, the initial step in collecting conducted emission data is a spectrum analyzer peak detector mode pre-scanning the measurement frequency range. Significant peaks are then marked and then Quasi Peak detector mode re-measured. If the emission level of the EUT measured by the peak detector is 3 dB lower than the applicable limit, the peak emission level will be reported. Otherwise, the emission measurement will be repeated using the quasi-peak detector and reported.

Above 1G

The setting of the spectrum analyser

RBW	1 MHz
VBW	PEAK: 3 MHz AVG: see note 6
Sweep	Auto
Detector	Peak
Trace	Max hold

1. The testing follows the guidelines in ANSI C63.10-2013 clause 6.6.
2. The EUT was arranged to its worst case and then tune the antenna tower (from 1 m to 4 m) and turntable (from 0 degree to 360 degrees) to find the maximum reading. A pre-amp and a high pass filter are used for the test in order to get better signal level. Both horizontal and vertical polarizations of the antenna are set to make the measurement.
3. The EUT was placed on a turntable with 1.5 m above ground.
4. The EUT was set 3 meters from the interference receiving antenna, which was mounted on the top of a variable height antenna tower.
5. For measurement above 1 GHz, the emission measurement will be measured by the peak detector. This peak level, once corrected, must comply with the limit specified in Section 15.209.
6. For measurements above 1 GHz the resolution bandwidth is set to 1 MHz, then the video bandwidth is set to 3 MHz for peak measurements and 1 MHz resolution bandwidth with 1/T video bandwidth with peak detector for average measurements. For the Duty Cycle please refer to clause 7.1.ON TIME AND DUTY CYCLE.

X axis, Y axis, Z axis positions:

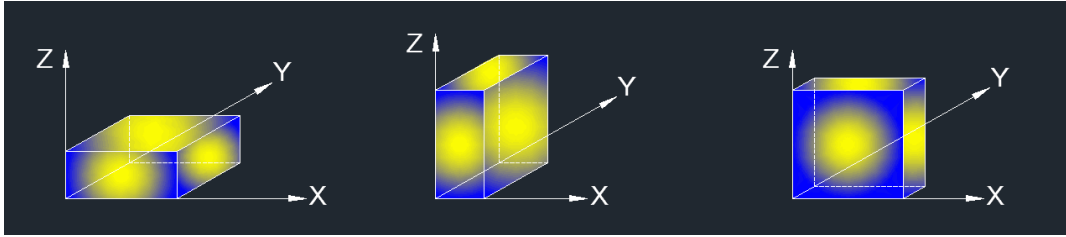

Note 1: For all radiated test, EUT in each of three orthogonal axis emissions had been tested, but only the worst case (X axis) data recorded in the report.

**TEST SETUP**

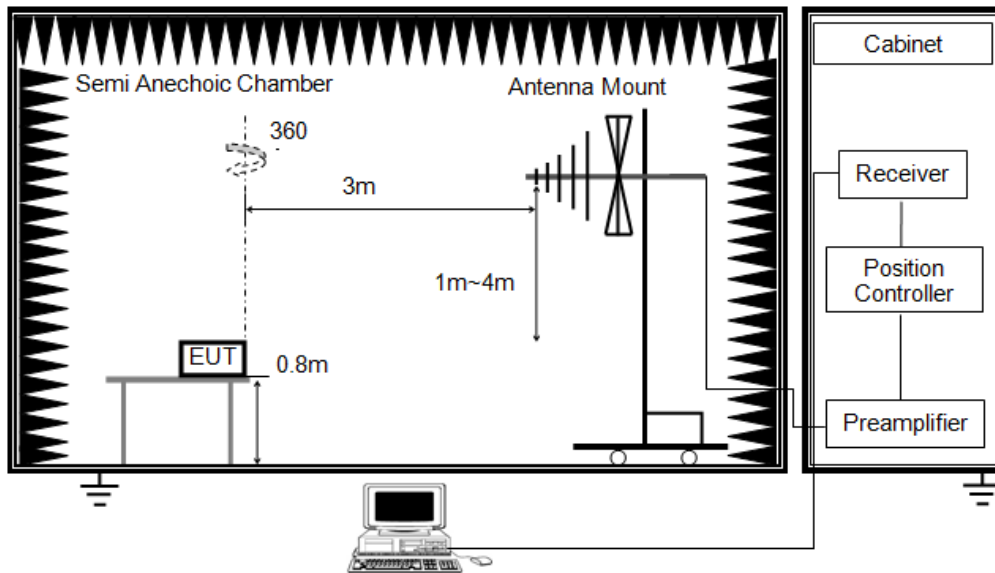
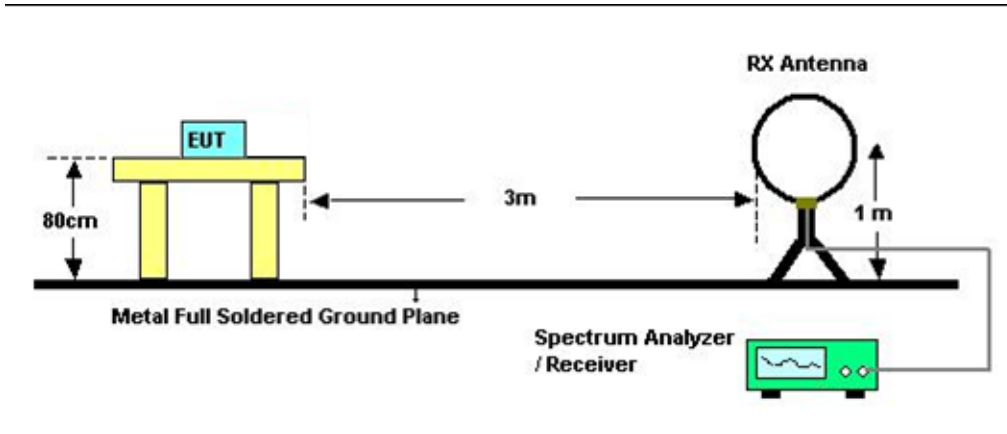

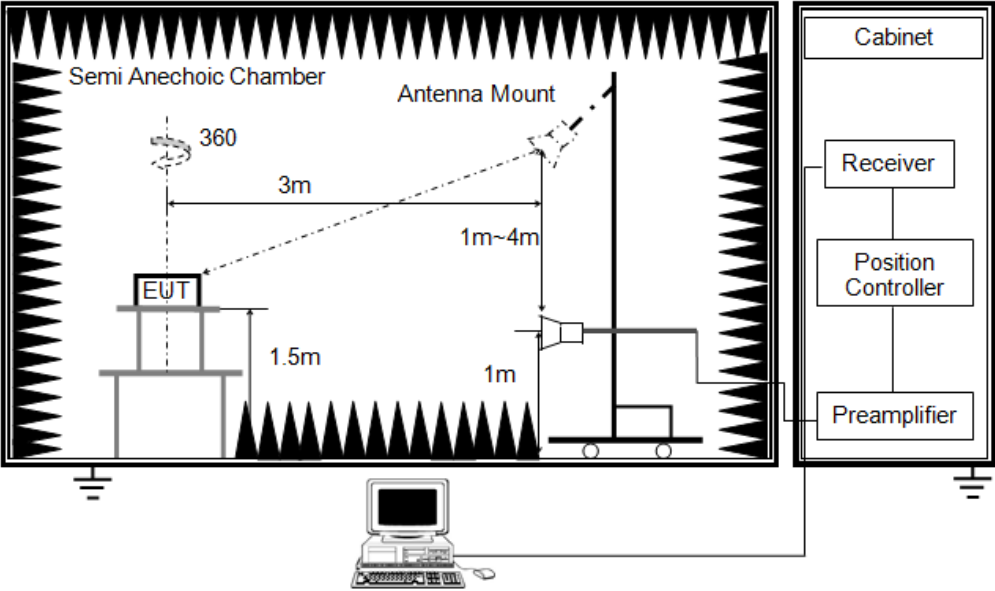

**TEST ENVIRONMENT**

Temperature	24°C	Relative Humidity	55%
Atmosphere Pressure	101kPa		



**TEST RESULTS**

- Undesirable radiated Spurious Emission below 1GHz (30MHz to 1GHz)

The worst result as bellow:

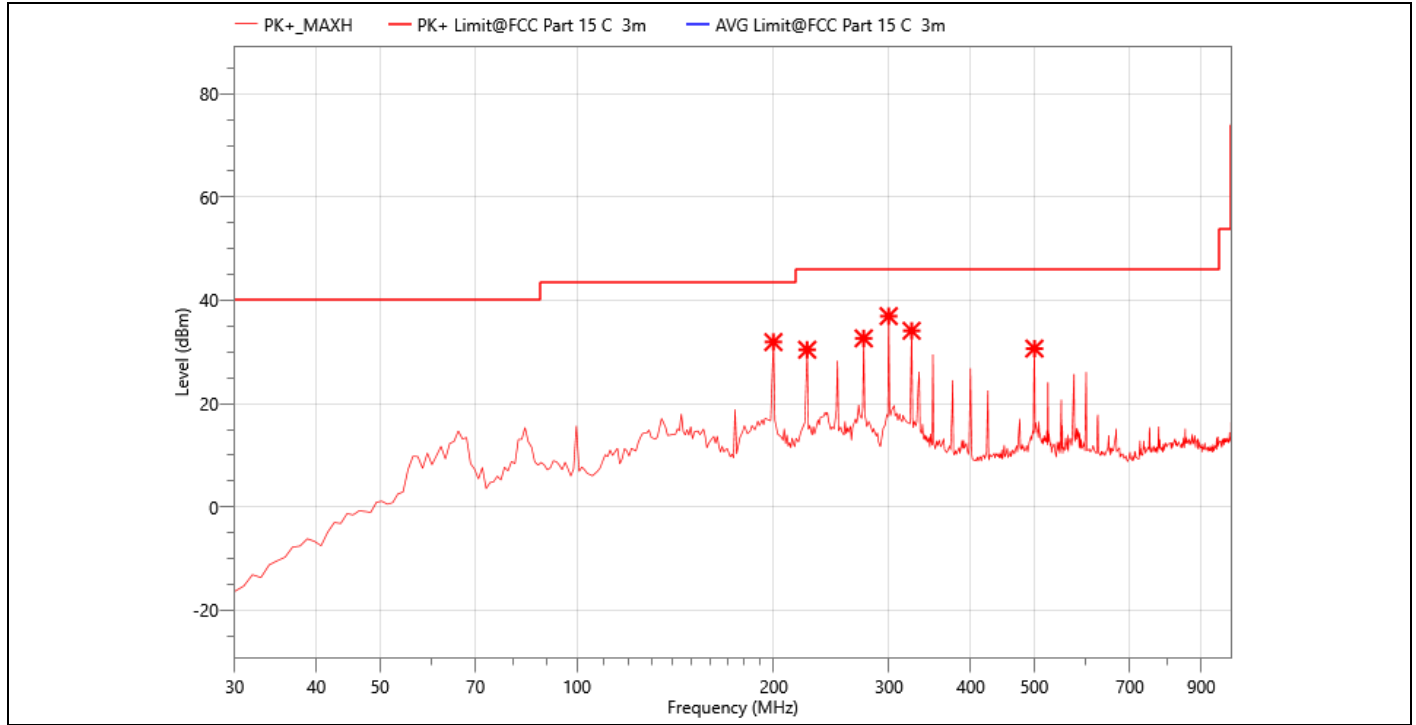

<b>Site:</b>	<b>FCC Part 15 C 3m Radiation(QP)</b>	<b>Antenna: Horizontal</b>	<b>Temperature(C):23(C)</b>
<b>Limit:</b>	<b>Indoor Wi-Fi IP Plug In 1080p</b>	<b>Test Time:</b>	<b>Humidity(%):57%</b>
<b>EUT:</b>	<b>Deterrence Camera with 2-Way Audio – White</b>	<b>Power Rating:</b>	<b>2023-05-17</b>
<b>M/N.:</b>	<b>WCM-FWIP2-I</b>	<b>Test Engineer:</b>	<b>DC 5V</b>
<b>Mode:</b>	<b>802.11b 2412MHz</b>		<b>Mace</b>
<b>Note:</b>			

Freq. (MHz)	Reading (dBµV)	Meas. (dBµV/m)	Limit (dBµV/m)	Margin (dBµV/m)	Det.	Height (cm)	Pol.	Azimuth (deg)	Corr. (dB)
199.75	51.99	31.93	43.50	11.57	PK+	149.9	H	360.0	-20.06
224.97	50.19	30.45	46.00	15.55	PK+	149.9	H	360.0	-19.74
274.44	53.21	32.65	46.00	13.35	PK+	149.9	H	360.0	-20.56
299.66	56.44	36.95	46.00	9.05	PK+	149.9	H	360.0	-19.49
324.88	52.43	34.12	46.00	11.88	PK+	149.9	H	360.0	-18.31
500.45	49.85	30.67	46.00	15.33	PK+	149.9	H	360.0	-19.18

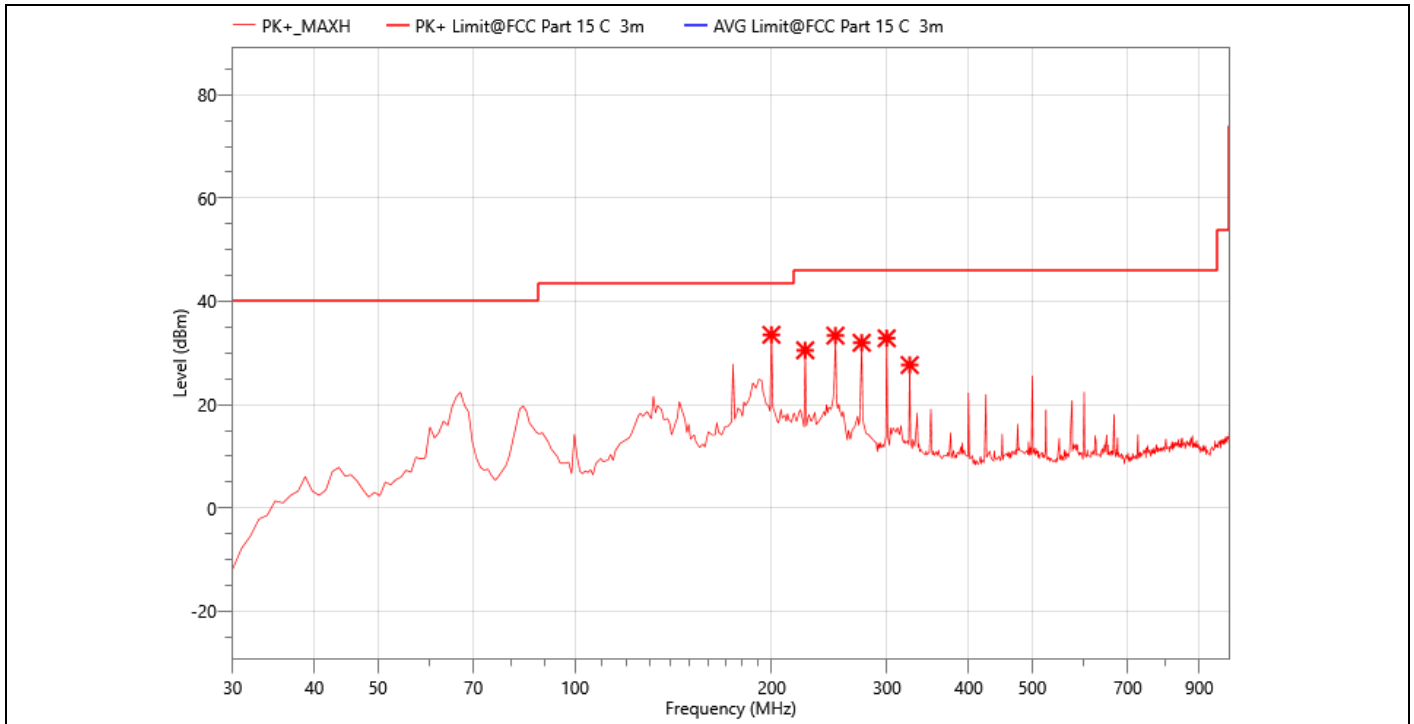

<b>Site:</b>	<b>FCC Part 15 C 3m Radiation(QP)</b>	<b>Antenna: Vertical</b>	<b>Temperature(C):23(C)</b>
<b>Limit:</b>	<b>Indoor Wi-Fi IP Plug In 1080p</b>	<b>Test Time:</b>	<b>Humidity(%):57%</b>
<b>EUT:</b>	<b>Deterrence Camera with 2-Way Audio – White</b>	<b>Power Rating:</b>	<b>2023-05-17</b>
<b>M/N.:</b>	<b>WCM-FWIP2-I</b>	<b>Test Engineer:</b>	<b>DC 5V</b>
<b>Mode:</b>	<b>802.11b 2412MHz</b>		<b>Mace</b>
<b>Note:</b>			

Freq. (MHz)	Reading (dBμV)	Meas. (dBμV/m)	Limit (dBμV/m)	Margin (dBμV/m)	Det.	Height (cm)	Pol.	Azimuth (deg)	Corr. (dB)
199.75	53.59	33.53	43.50	9.97	PK+	149.9	V	0.0	-20.06
224.97	50.27	30.53	46.00	15.47	PK+	149.9	V	0.0	-19.74
250.19	53.67	33.37	46.00	12.63	PK+	149.9	V	0.0	-20.3
274.44	52.54	31.98	46.00	14.02	PK+	149.9	V	0.0	-20.56
299.66	52.34	32.85	46.00	13.15	PK+	149.9	V	0.0	-19.49
324.88	45.99	27.68	46.00	18.32	PK+	149.9	V	0.0	-18.31

Note: 1. Result Level = Read Level+ Antenna Factor+ Cable Loss- Amp. Factor

● Undesirable radiated Spurious Emission Above 1GHz (1GHz to 40GHz)

All modes has been tested and the worst result (801.11b) recorded as below:

Temperature :	23°C	Test Date :	2023-05-17
Humidity :	57 %	Test By:	Mace
Test mode:	801.11b	Frequency(MHz):	2412

Freq. (MHz)	Reading (dBμV)	Meas. (dBμV/m)	Limit (dBμV/m)	Margin (dBμV/m)	Det.	Height (cm)	Pol.	Azimuth (deg)	Corr. (dB)
1664	62.92	41.23	74.00	32.77	PK+	100.1	V	-0.6	-21.69
1762	60.8	39.92	74.00	34.08	PK+	100.1	V	-0.6	-20.88
1824	65.38	45.03	74.00	28.97	PK+	100.1	V	-0.6	-20.35
2000	62.01	43.12	74.00	30.88	PK+	100.1	V	-0.6	-18.89
7230	57.24	50.74	74.00	23.26	PK+	149.9	V	360.1	-6.5
11880	48.84	48.09	74.00	25.91	PK+	149.9	V	360.1	-0.75
15840	47.34	51.02	74.00	22.98	PK+	149.9	V	360.1	3.68
1366	57.8	34.44	74.00	39.56	PK+	149.9	H	360.0	-23.36
1666	58.69	37.01	74.00	36.99	PK+	149.9	H	360.0	-21.68
1826	63.81	43.48	74.00	30.52	PK+	149.9	H	360.0	-20.33
2010	58.85	39.99	74.00	34.01	PK+	149.9	H	360.0	-18.86
4815	60.7	49.29	74.00	24.71	PK+	149.9	H	360.1	-11.41
7230	54.11	47.61	74.00	26.39	PK+	149.9	H	360.1	-6.5
11160	48.84	48.18	74.00	25.82	PK+	149.9	H	360.1	-0.66

Temperature :	23°C	Test Date :	2023-05-17
Humidity :	57 %	Test By:	Mace
Test mode:	801.11b	Frequency(MHz):	2437

Freq. (MHz)	Reading (dBμV)	Meas. (dBμV/m)	Limit (dBμV/m)	Margin (dBμV/m)	Det.	Height (cm)	Pol.	Azimuth (deg)	Corr. (dB)
1360	57.71	34.34	74.00	39.66	PK+	149.9	V	360.1	-23.37
1762	58.67	37.79	74.00	36.21	PK+	149.9	V	360.1	-20.88
1888	65.92	46.08	74.00	27.92	PK+	149.9	V	360.1	-19.84
2678	68.46	51.13	74.00	22.87	PK+	149.9	V	360.1	-17.33
7305	55.93	49.97	74.00	24.03	PK+	149.9	V	360.1	-5.96
11250	49.45	48.56	74.00	25.44	PK+	149.9	V	360.1	-0.89
13995	48.26	49.02	74.00	24.98	PK+	149.9	V	360.1	0.76
1640	59.44	37.52	74.00	36.48	PK+	149.9	H	360.1	-21.92
1888	66.47	46.63	74.00	27.37	PK+	149.9	H	360.1	-19.84
2002	59.8	40.91	74.00	33.09	PK+	149.9	H	360.1	-18.89
2678	67.4	50.07	74.00	23.93	PK+	149.9	H	360.1	-17.33
7305	51.62	45.66	74.00	28.34	PK+	149.9	H	360.1	-5.96
12435	49.42	48.43	74.00	25.57	PK+	149.9	H	360.1	-0.99
14205	48.81	49.82	74.00	24.18	PK+	149.9	H	360.1	1.01

Temperature :	23°C	Test Date :	2023-05-17
Humidity :	57 %	Test By:	Mace
Test mode:	801.11b	Frequency(MHz):	2462

Freq. (MHz)	Reading (dB $\mu$ V)	Meas. (dB $\mu$ V/m)	Limit (dB $\mu$ V/m)	Margin (dB $\mu$ V/m)	Det.	Height (cm)	Pol.	Azimuth (deg)	Corr. (dB)
1598	60.21	37.92	74.00	36.08	PK+	149.9	V	360.1	-22.29
1800	59.2	38.61	74.00	35.39	PK+	149.9	V	360.1	-20.59
1950	65.97	46.71	74.00	27.29	PK+	149.9	V	360.1	-19.26
2602	59.71	42.27	74.00	31.73	PK+	149.9	V	360.1	-17.44
2878	68.8	52.1	74.00	21.9	PK+	149.9	V	360.1	-16.7
7380	52.59	45.98	74.00	28.02	PK+	149.9	V	360.1	-6.61
11190	49.07	48.05	74.00	25.95	PK+	149.9	V	360.1	-1.02
14085	48.05	48.83	74.00	25.17	PK+	149.9	V	360.1	0.78
1906	60.15	40.44	74.00	33.56	PK+	149.9	H	360.1	-19.71
1950	66.61	47.35	74.00	26.65	PK+	149.9	H	360.1	-19.26
2000	67.81	48.92	74.00	25.08	PK+	149.9	H	360.1	-18.89
2878	69.42	52.72	74.00	21.28	PK+	149.9	H	360.1	-16.7
7275	51.11	44.76	74.00	29.24	PK+	149.9	H	360.1	-6.35
11250	48.68	47.79	74.00	26.21	PK+	149.9	H	360.1	-0.89
13680	48.49	49.16	74.00	24.84	PK+	149.9	H	360.1	0.67

**Other harmonics emissions are lower than 20dB below the allowable limit.**

Note: (1) All Readings are Peak Value (VBW=3MHz) and Peak Value (VBW=10Hz).

(2) Emission Level= Reading Level+Probe Factor +Cable Loss.

(3) EIRP[dBm] = E[dB $\mu$ V/m] + 20 log(d[meters]) - 104.77

d is the measurement distance in 3 meters

● Band Edge

**802.11b 2412MHz**  
 Horizontal

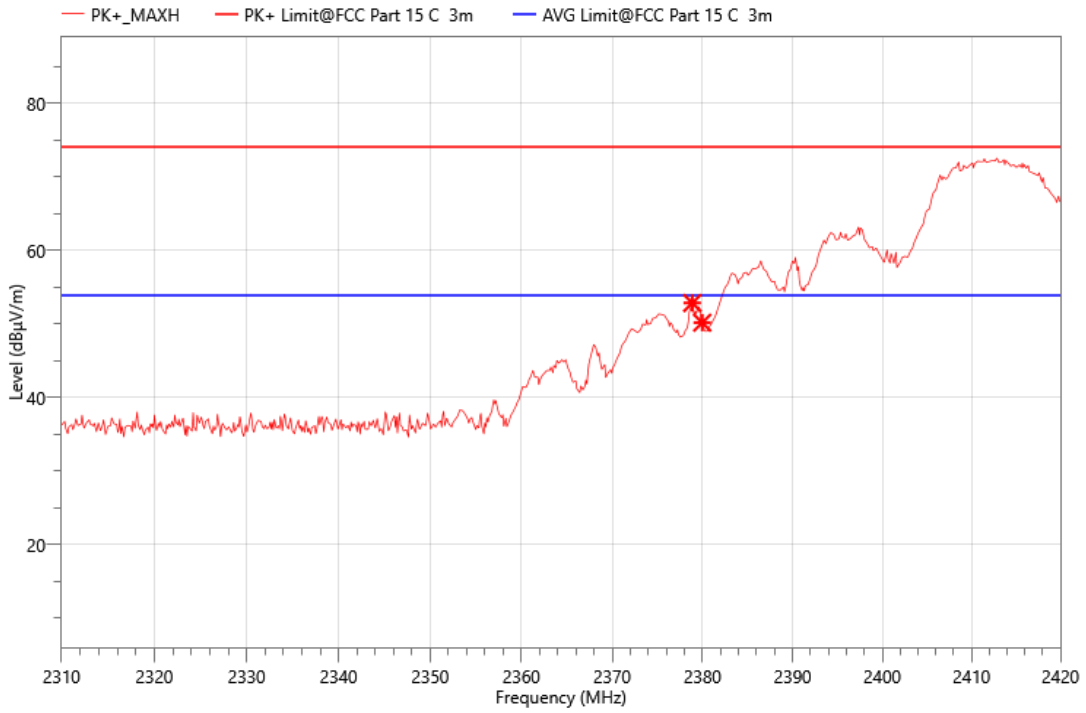

Freq. (MHz)	Reading (dBµV)	Meas. (dBµV/m)	Limit (dBµV/m)	Margin (dBµV/m)	Det.	Height (cm)	Pol.	Azimuth (deg)	Corr. (dB)
2378.86	70.86	52.85	74.00	21.15	PK+	149.9	H	360.1	-18.01
2379.96	68.18	50.18	74.00	23.82	PK+	149.9	H	360.1	-18

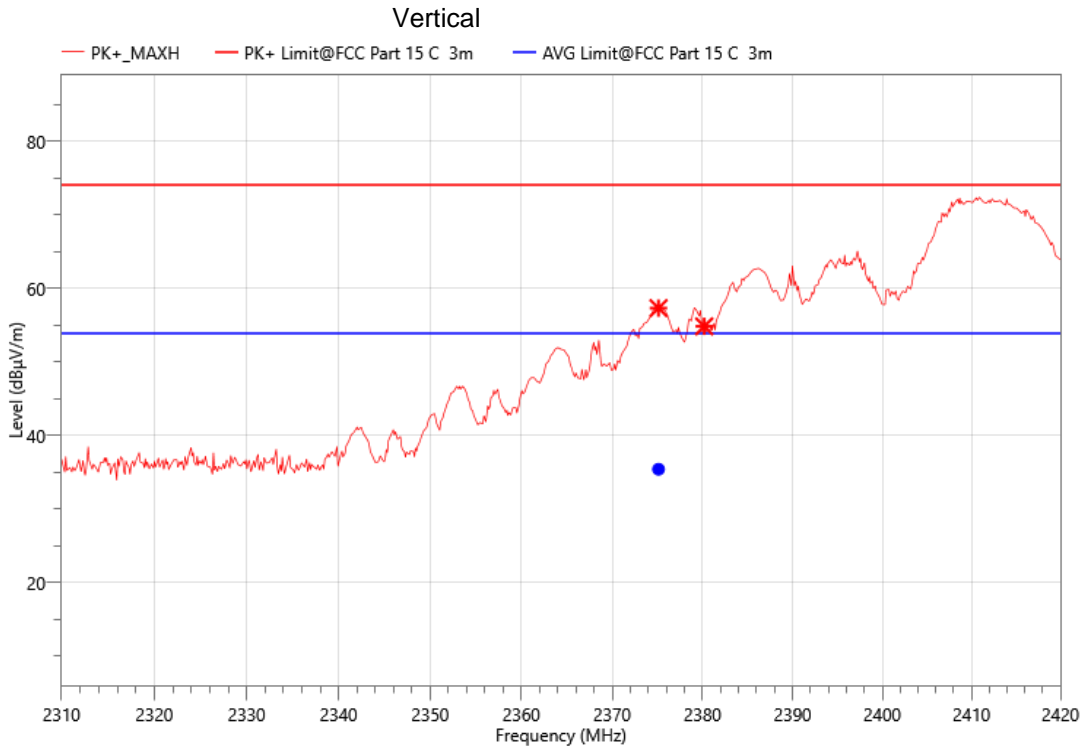

Freq. (MHz)	Reading (dBµV)	Meas. (dBµV/m)	Limit (dBµV/m)	Margin (dBµV/m)	Det.	Height (cm)	Pol.	Azimuth (deg)	Corr. (dB)
2375.12	75.33	57.33	74.00	16.67	PK+	149.9	V	360.1	-18
2375.12	53.42	35.42	53.90	18.48	AVG	149.9	V	360.1	-18
2380.18	72.85	54.85	74.00	19.15	PK+	149.9	V	360.1	-18

**802.11b 2462MHz**  
 Horizontal

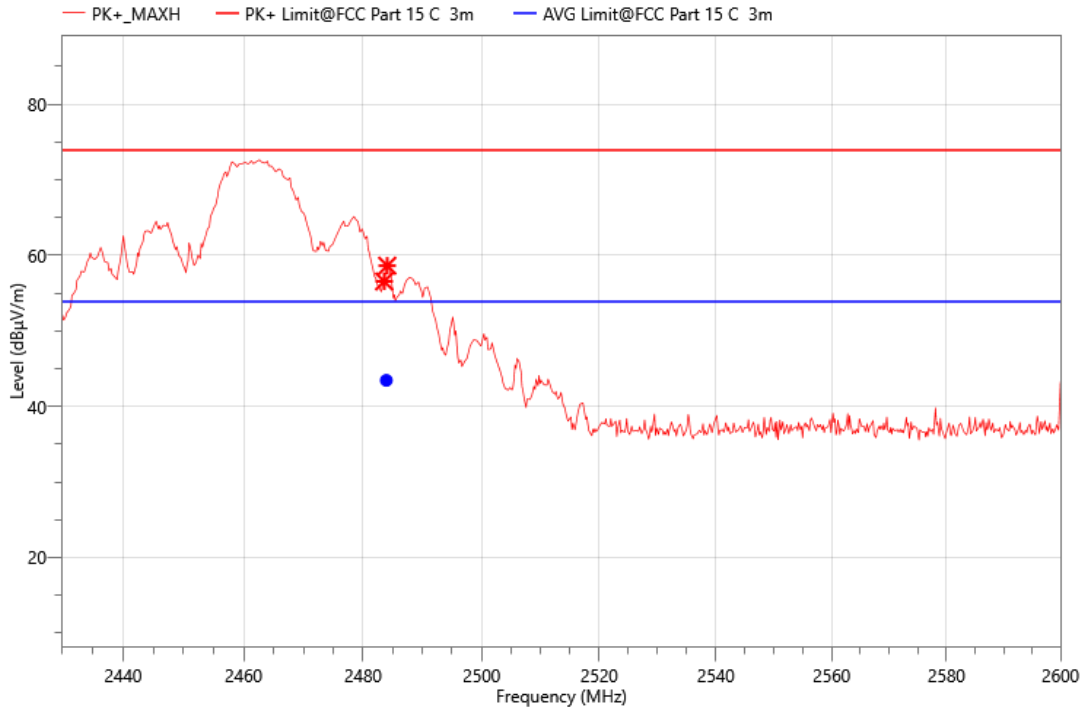

Freq. (MHz)	Reading (dBµV)	Meas. (dBµV/m)	Limit (dBµV/m)	Margin (dBµV/m)	Det.	Height (cm)	Pol.	Azimuth (deg)	Corr. (dB)
2483.55	74.26	56.55	74.00	17.45	PK+	149.9	H	360.1	-17.71
2483.90	61.16	43.45	53.90	10.45	AVG	149.9	H	360.1	-17.71
2484.06	76.34	58.63	74.00	15.37	PK+	149.9	H	360.1	-17.71

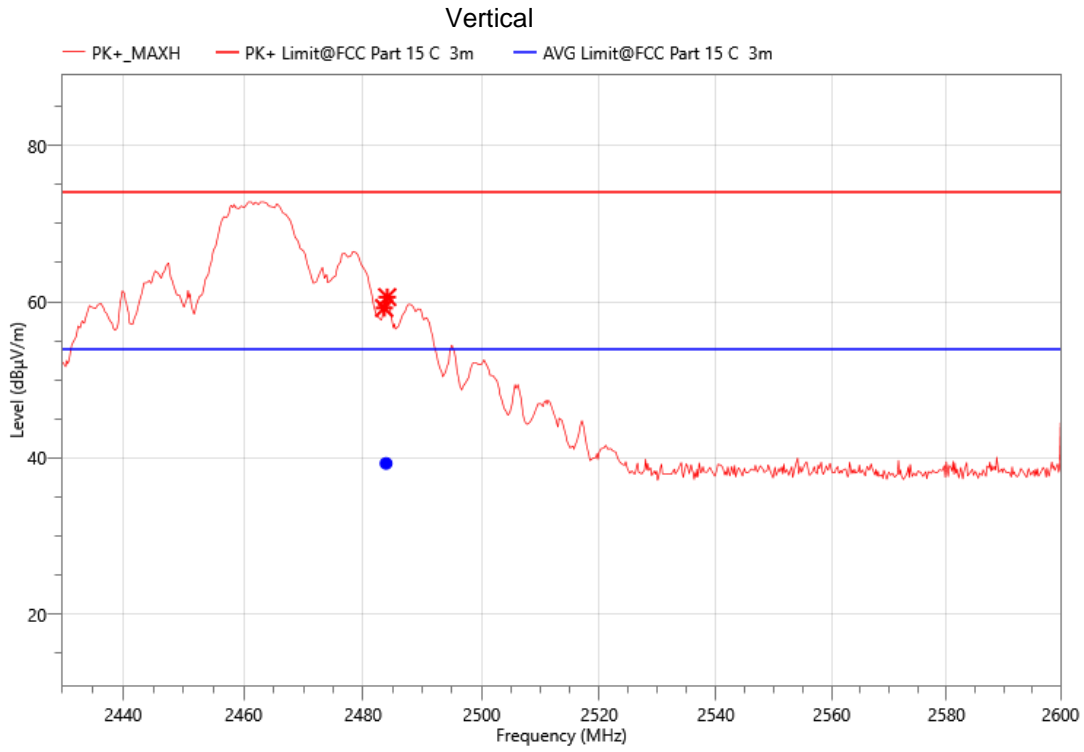

Freq. (MHz)	Reading (dBµV)	Meas. (dBµV/m)	Limit (dBµV/m)	Margin (dBµV/m)	Det.	Height (cm)	Pol.	Azimuth (deg)	Corr. (dB)
2483.55	76.91	59.2	74.00	14.8	PK+	149.9	V	360.1	-17.71
2483.85	57.03	39.32	53.90	14.58	AVG	149.9	V	360.1	-17.71
2484.06	78.31	60.6	74.00	13.4	PK+	149.9	V	360.1	-17.71

Note:802.11b, 802.11g, 802.11n (HT-20), 802.11n (HT-40), all has been tested, the worst case is 802.11a, only shown the worst case.



## 9. ANTENNA REQUIREMENT

### REQUIREMENT

Please refer to FCC §15.203

An intentional radiator shall be designed to ensure that no antenna other than that furnished by the responsible party shall be used with the device. The use of a permanently attached antenna or of an antenna that uses a unique coupling to the intentional radiator shall be considered sufficient to comply with the provisions of this section. The manufacturer may design the unit so that a broken antenna can be replaced by the user, but the use of a standard antenna jack or electrical connector is prohibited.

Please refer to FCC §15.247(b)(4)

The conducted output power limit specified in paragraph (b) of this section is based on the use of antennas with directional gains that do not exceed 6 dBi. Except as shown in paragraph (c) of this section, if transmitting antennas of directional gain greater than 6 dBi are used, the conducted output power from the intentional radiator shall be reduced below the stated values in paragraphs (b)(1), (b)(2), and (b)(3) of this section, as appropriate, by the amount in dB that the directional gain of the antenna exceeds 6 dBi.

### DESCRIPTION

Pass

## 10. AC POWER LINE CONDUCTED EMISSION

### LIMITS

Please refer to CFR 47 FCC §15.207 (a) and ISED RSS-Gen Clause 8.8

FREQUENCY (MHz)	Quasi-peak	Average
0.15 -0.5	66 - 56 *	56 - 46 *
0.50 -5.0	56.00	46.00
5.0 -30.0	60.00	50.00

### TEST PROCEDURE

The EUT is put on a table of non-conducting material that is 80 cm high. The vertical conducting wall of shielding is located 40 cm to the rear of the EUT. The power line of the EUT is connected to the AC mains through a Artificial Mains Network (A.M.N.). A EMI Measurement Receiver (R&S Test Receiver ESR3) is used to test the emissions from both sides of AC line. According to the requirements in Section 6.2 of ANSI C63.10-2013. Conducted emissions from the EUT measured in the frequency range between 0.15 MHz and 30 MHz using CISPR Quasi-Peak and average detector mode. The bandwidth of EMI test receiver is set at 9 kHz.

The arrangement of the equipment is installed to meet the standards and operating in a manner, which tends to maximize its emission characteristics in a normal application.

### TEST SETUP

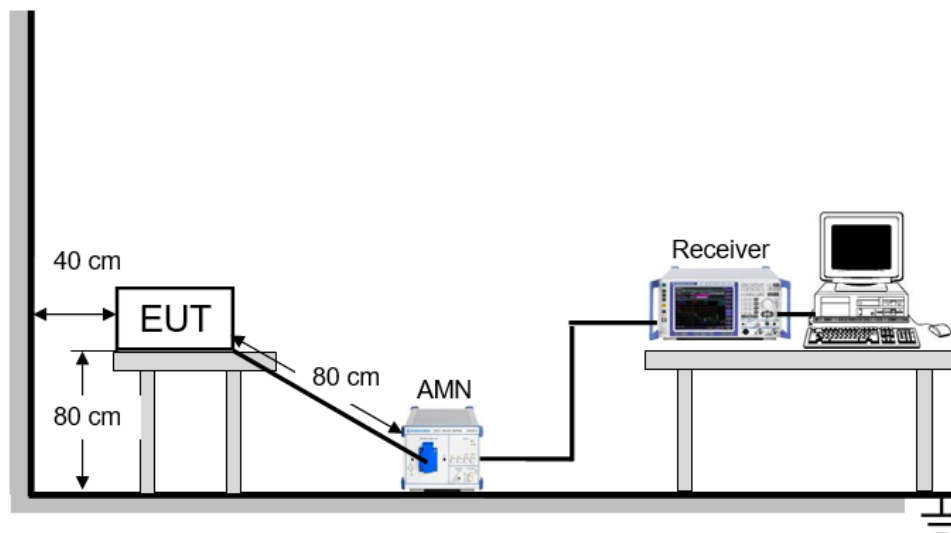

### TEST ENVIRONMENT

Temperature	24°C	Relative Humidity	55%
Atmosphere Pressure	101kPa		

**TEST RESULTS**

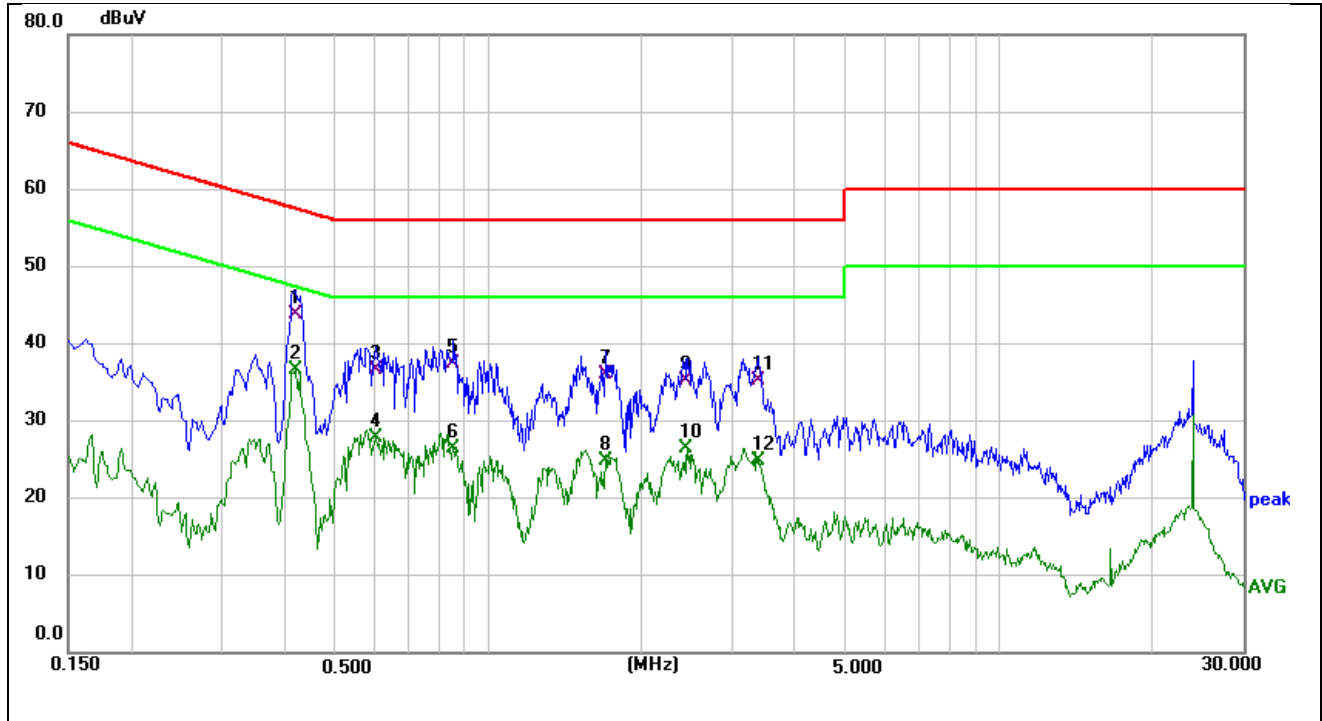

<b>Site:</b>		<b>Phase:</b> L1	<b>Temperature(C):</b> 23.5(C)
<b>Limit:</b>	FCC Part 15 C Conduction(QP)		<b>Humidity(%):</b> 52.6%
<b>EUT:</b>	Indoor Wi-Fi IP Plug In 1080p Deterrence Camera with 2-Way Audio – White	<b>Test Time:</b>	2023/5/16
<b>M/N.:</b>	WCM-FWIP2-I	<b>Power Rating:</b>	AC 120V/60Hz
<b>Mode:</b>	WIFI mode	<b>Test Engineer:</b>	Aiden
<b>Note:</b>	2.4G WIFI mode 11B 2412MHz		

No.	Frequency (MHz)	Reading Level(dBuV)	Factor (dB)	Measurement(dBuV)	Limit (dBuV)	Margin (dB)	Detector
1	0.4180	32.51	11.19	43.70	57.49	-13.79	QP
2 *	0.4180	25.43	11.19	36.62	47.49	-10.87	AVG
3	0.6020	25.14	11.56	36.70	56.00	-19.30	QP
4	0.6020	16.34	11.56	27.90	46.00	-18.10	AVG
5	0.8540	27.02	10.38	37.40	56.00	-18.60	QP
6	0.8540	16.14	10.38	26.52	46.00	-19.48	AVG
7	1.7020	25.70	10.40	36.10	56.00	-19.90	QP
8	1.7020	14.42	10.40	24.82	46.00	-21.18	AVG
9	2.4539	24.78	10.42	35.20	56.00	-20.80	QP
10	2.4539	15.93	10.42	26.35	46.00	-19.65	AVG
11	3.3740	24.76	10.44	35.20	56.00	-20.80	QP
12	3.3740	14.31	10.44	24.75	46.00	-21.25	AVG

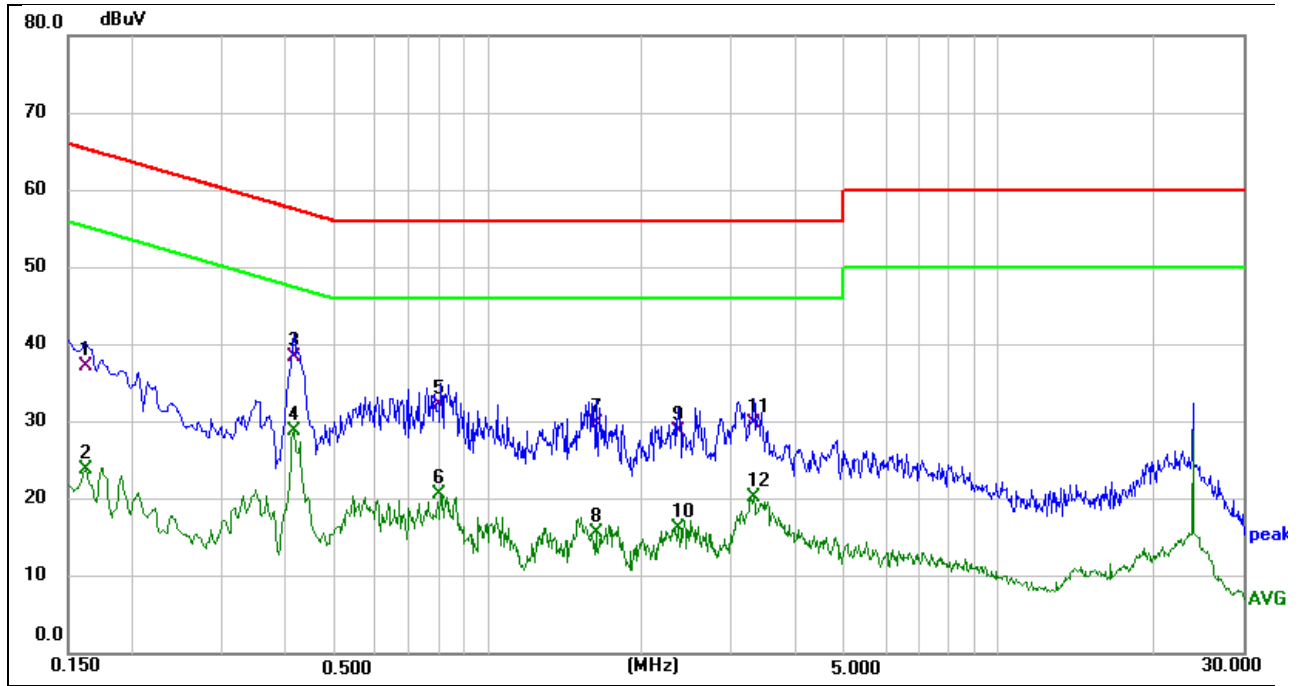

Site:	Phase:N	Temperature(C):23.5(C)
Limit: FCC Part 15 C Conduction(QP)	Test Time:	Humidity(%):52.6%
EUT: Indoor Wi-Fi IP Plug In 1080p Deterrence Camera with 2-Way Audio – White	Power Rating: AC 120V/60Hz	2023/5/16
M/N.: WCM-FWIP2-I	Test Engineer: Aiden	
Mode: WIFI mode		
Note: 2.4G WIFI mode 11B 2412MHz		

No.	Frequency (MHz)	Reading Level(dBuV)	Factor (dB)	Measurement(dBuV)	Limit (dBuV)	Margin (dB)	Detector
1	0.1620	26.62	10.58	37.20	65.36	-28.16	QP
2	0.1620	13.35	10.58	23.93	55.36	-31.43	AVG
3	0.4140	27.41	11.09	38.50	57.57	-19.07	QP
4 *	0.4140	17.80	11.09	28.89	47.57	-18.68	AVG
5	0.8059	21.90	10.30	32.20	56.00	-23.80	QP
6	0.8059	10.38	10.30	20.68	46.00	-25.32	AVG
7	1.6220	19.57	10.33	29.90	56.00	-26.10	QP
8	1.6220	5.43	10.33	15.76	46.00	-30.24	AVG
9	2.3540	18.55	10.35	28.90	56.00	-27.10	QP
10	2.3540	5.86	10.35	16.21	46.00	-29.79	AVG
11	3.2980	19.53	10.37	29.90	56.00	-26.10	QP
12	3.2980	9.93	10.37	20.30	46.00	-25.70	AVG

- Note: 1. Result = Reading + Correct Factor.  
 2. If QP Result complies with AV limit, AV Result is deemed to comply with AV limit.  
 3. Test setup: RBW: 200 Hz (9 kHz ~ 150 kHz), 9 kHz (150 kHz ~ 30 MHz).  
 4. Step size: 80 Hz (0.009 MHz ~ 0.15 MHz), 4 kHz (0.15 MHz ~ 30 MHz), Scan time: auto.

Note: All the modes have been tested, only the worst data was recorded in the report.

## 11. ST DATA

Please refer to section "Test Data" - Appendix A

## APPENDIX: PHOTOGRAPHS OF TEST CONFIGURATION

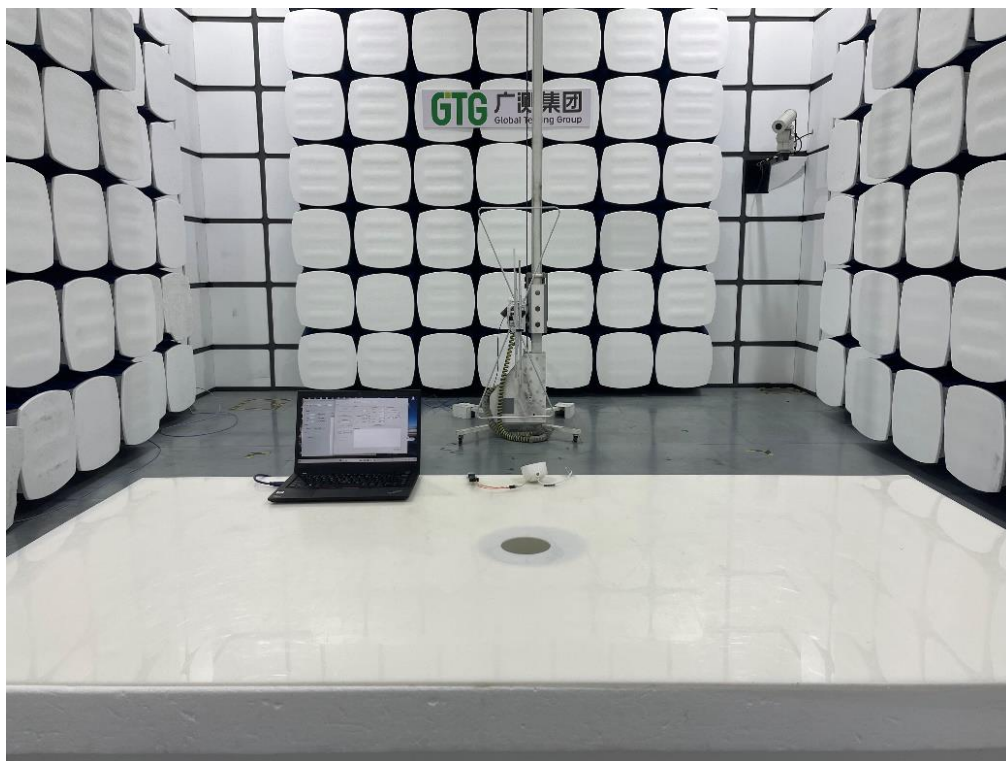



## APPENDIX: PHOTOGRAPHS OF THE EUT









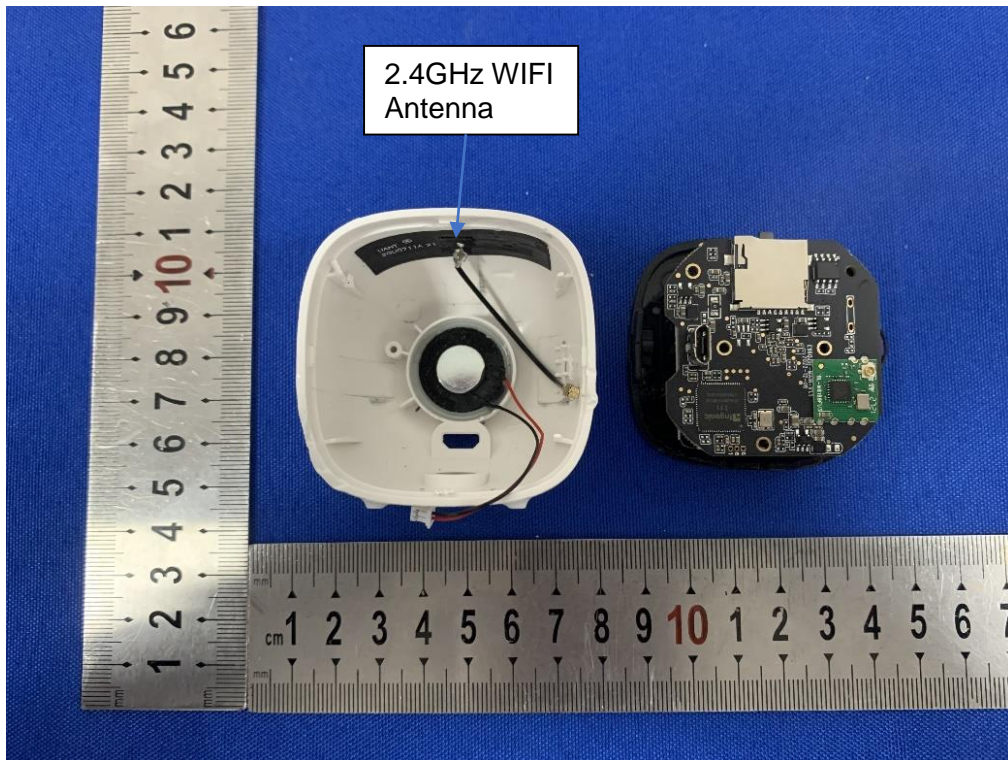

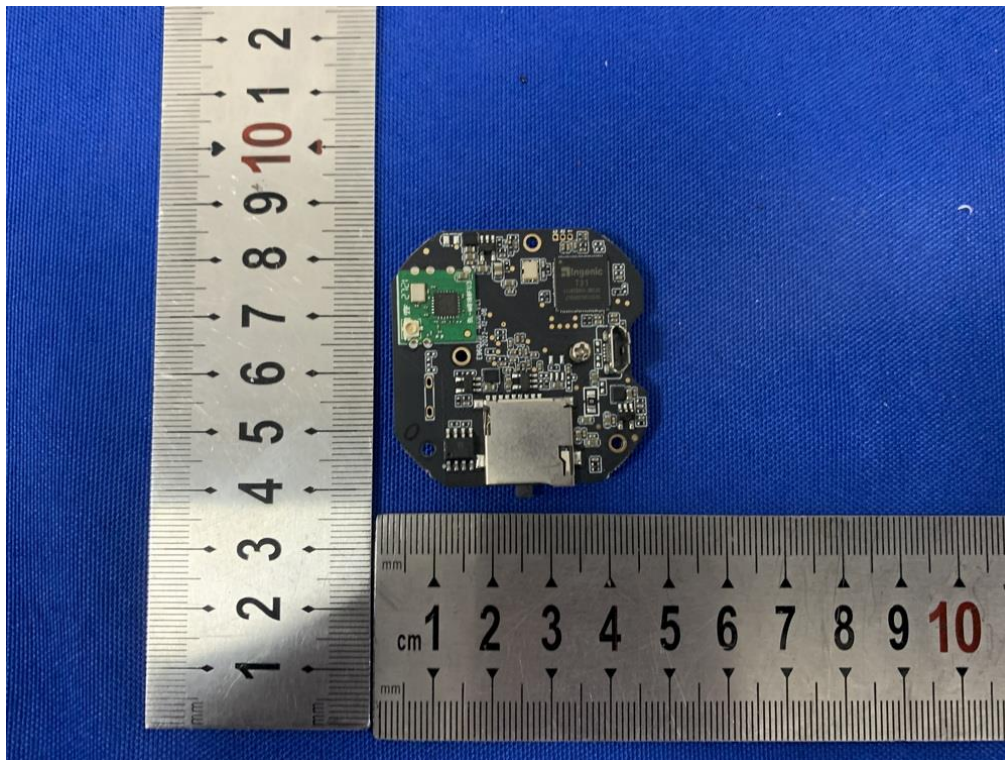
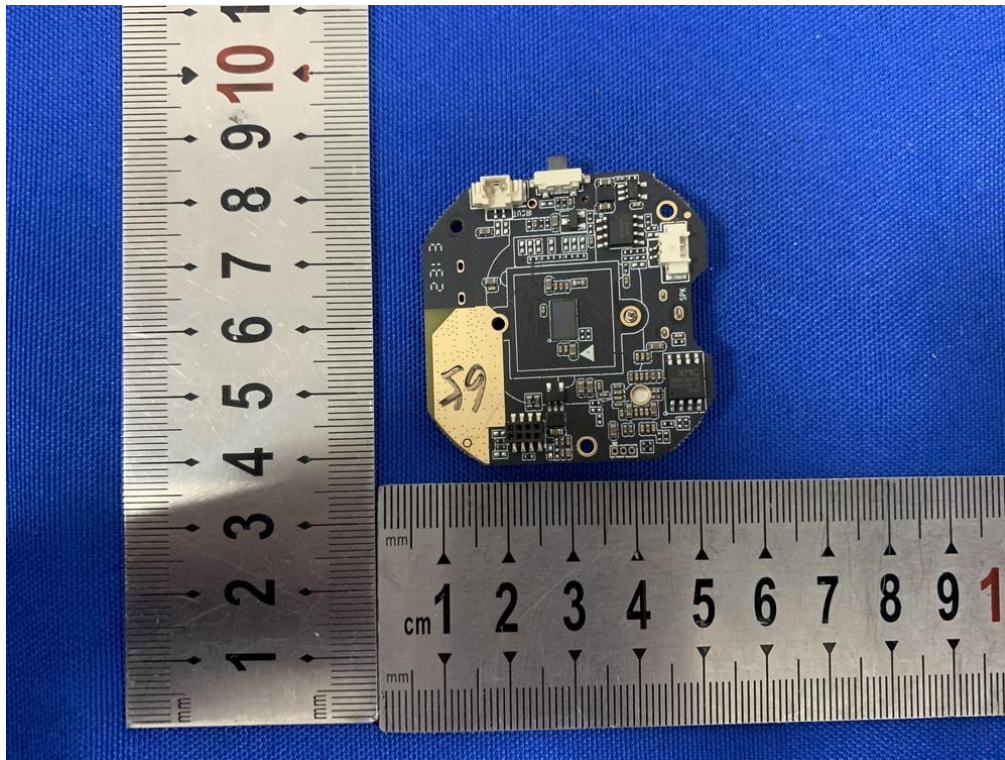

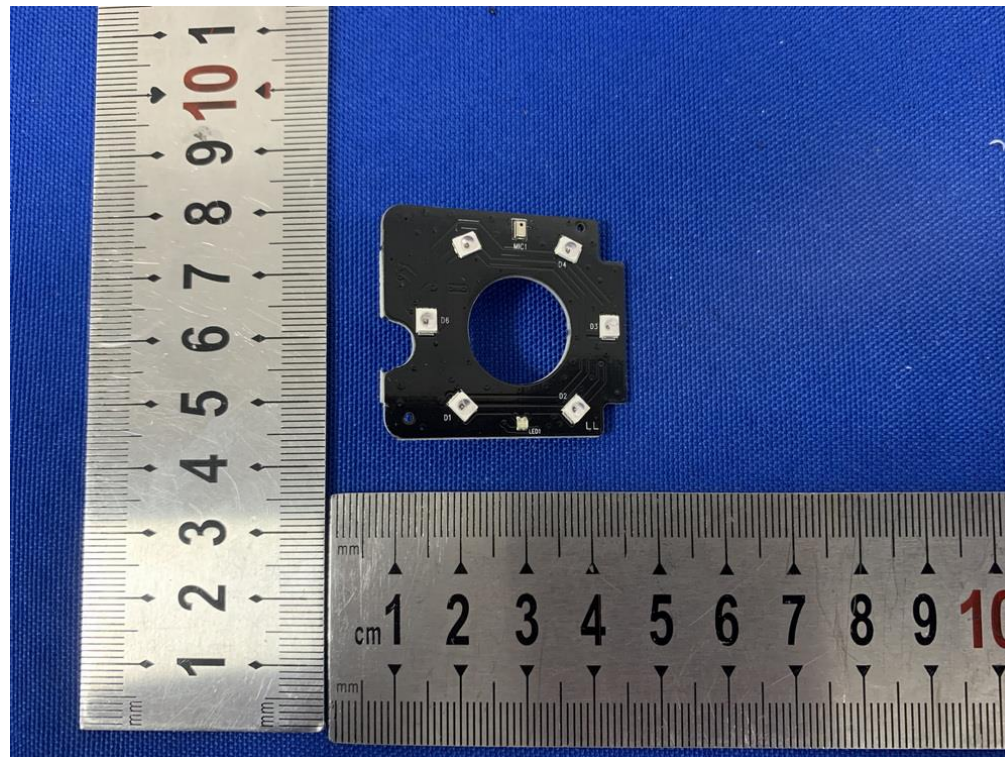
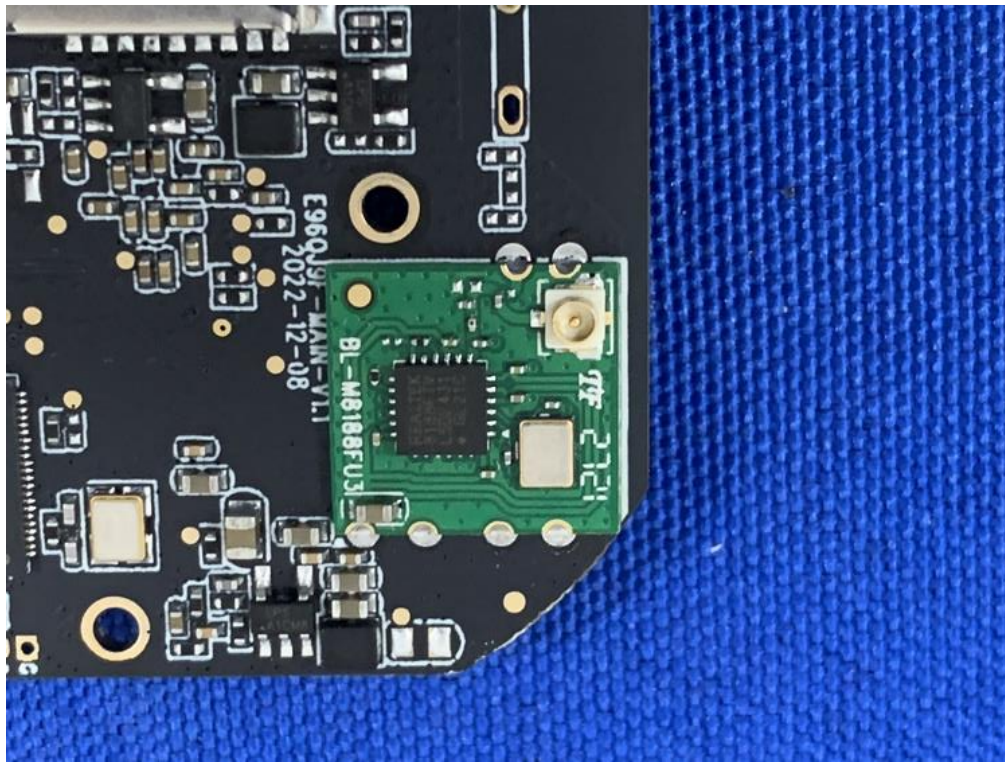

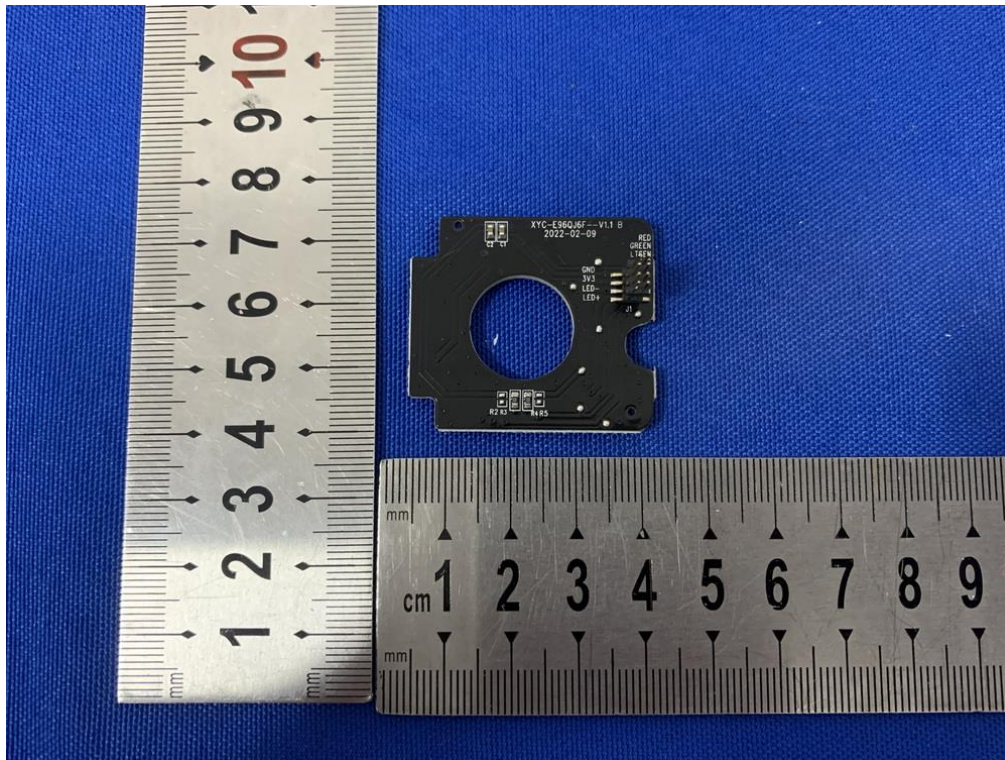

**END OF REPORT**