

SPECIFICATION FOR APPROVAL

Product name: WIFI Antenna

Product number: UB01C75F3D1565A

CUST.Material Name: E938J3F-V2 WiFi Antenna FPC UB01C65F2D2800A

CUST.Specifications: Frequency2.4G Built-in FPC Gray cable L=65mm±3mm+ Connector ROHS

CUST.Material code: 18600E9380004

Changed contents Resume:

No.	Before the change	After	Date	Version	pages	Responsible
0	first edition	first edition	2022-6-29	A0	10	Eddy

Supplier name: Dongguan Youbi Electronics Co.,Ltd		
Supplier address: Building 79, New Sun Industrial City, No. 9 Xinfu Road, Lincun, Tangxia Town, Dongguan City		
Phone: 0769-81777126	Fax: 0769-81777126	Email: zq@ub-rf.com
(Signed by the supplier)		
Responsible/Date	Audit/Date	Approve/Date

This admission book includes the following contents :(none is absent)

1. Cover
2. Parameter Specification
3. Structural dimension drawing
4. BOM
5. Packaging
6. Production process flow chart
7. Certification Test Status

Customer name:			
Customer determines the result: <input type="checkbox"/> Qualified <input type="checkbox"/> Unqualified			
Customer acknowledgement (please bookmark the whole acknowledgement back after confirmation)			
Development Design Engineer/Date	SQE Engineer /Date	Head of Purchasing Department/Date	Approved by Manager of Development Department/Date

2.Parameter Specification

2.1. Electrical performance parameter



No.	Project	Parameter specification	Test condition
1	Frequency(MHZ)	2400-2500MHz	Anechoic chamber
2	Gain	$\geq 2\text{dBi}$, $\leq 4\text{dBi}$	
3	Efficiency	$\geq 40\%$, $\leq 70\%$	
4	Impedance (Ω)	50	Network analyzer

2.2. Mechanical performance parameters

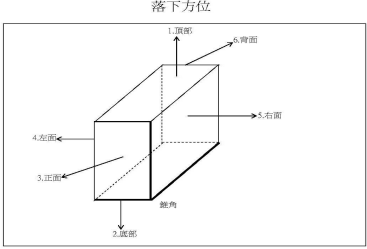

No.	Project	Parameter specification	Test condition
1	Cable length	$65 \pm 3(\text{mm})$	Use a steel ruler to measure, the length dimension is OK within 65 ± 3 (mm), otherwise it is NG.
2	FPC length	$30 \pm 0.5(\text{mm})$	Use a digital caliper to measure, the length dimension is OK within 30 ± 0.5 (mm), otherwise it is NG.
3	FPC width	$18.2 \pm 0.5(\text{mm})$	Use a digital caliper to measure, the length dimension is OK within 18.2 ± 0.5 (mm), otherwise it is NG.

2.3. Reliability test

No.	Project	Test conditions	Standard
1	Salt spray test	<p>Test specifications: test temperature: 35°C, salt solution concentration: 5% (the standard of pH value after the salt solution is modulated and cooled is between 6.5 and 7.2), the average amount of salt solution collected: 1.0 to 2.0 (ml/hr), Test time: 48 hours (terminal)/8H (wire)</p> <p>Experimental method: pour the prepared brine into the test solution storage bucket, place the tested object on the test sample rack, then close the test cover, and pour the water into the sealing tank until there is no gap. After testing for 48H/8H, If there is no oxidation on the surface of the product, it is OK, otherwise, it is NG.</p>	After 48H/8H, there is no oxidation on the surface of the product, and the electrical test is OK.
2	Terminal pull test	<p>Test method: adjust the height of the upper and lower cross arms to make the clamp spacing appropriate; clamp the upper end of the specimen with the upper clamp, and press the reset button to reset the pointer to zero;</p> <p>Press the dynamometer pointer to lock the switch; clamp the lower end of the specimen with the lower clamp; rotate the handwheel to lower the lower cross arm to stretch the specimen.</p>	If the tension value is $\geq 1.2\text{KG}$ read from the tension meter, it is judged as OK, otherwise it is NG.
3	Terminal pull test	<p>Test method: Buckle the terminal into the terminal seat, shake the handwheel to move the jaws of the pull-out test fixture to a suitable position; open the jaws to hook the back of the terminal. The pointer returns to zero, and the handwheel is shaken to start the test.</p>	If the tension value read on the tension meter is in the range of 0.8-1.5KG, it is judged as OK, otherwise it is NG.

4	<p>Test conditions:</p> <ol style="list-style-type: none"> Drop the 6 sides of the carton (Figure 1)  <p style="text-align: center;">Figure 1</p> <ol style="list-style-type: none"> The distance between the product and the floor steel plate is 80 CM(Figure 2)  <p style="text-align: center;">Figure 2</p> <p>Experiment method:</p> <ol style="list-style-type: none"> First, fix the packing box to be tested on the product bracket to fix and clamp the test sample. The clamping force should be appropriate to avoid pinching the tested sample. Adjust the drop height 80CM. First turn on the main power switch and connect the trachea. After the work is completed, disconnect the trachea and the power switch, and remove the sample. 	<ol style="list-style-type: none"> After the test, the packing box should not have obvious damage. After the test, inspect the product, and there must be no defects after the electrical & external inspection.
---	--	--

Coaxial Wire Material Addendum

7	<table border="1" style="width: 100%; border-collapse: collapse;"> <tr> <th style="width: 25%;">型号 Type</th> <td style="width: 25%;">RF-1.13/50</td> <th style="width: 25%;">料号 P/N</th> <td style="width: 25%;">SY113/50-064(Gray)</td> </tr> <tr> <td>结构图 Structure drawing</td> <td colspan="3" style="text-align: center;">  </td> </tr> <tr> <th colspan="4">结构特性 Structure characteristics</th> </tr> <tr> <th>结构 Structure</th> <th>项目 Item</th> <th colspan="2">标准值 Standard value</th> </tr> <tr> <td rowspan="3">①内导体 Inner conductor</td> <td>材料 Material</td> <td colspan="2">镀锡铜线 Tinned copper wire</td> </tr> <tr> <td>组成:总根数/单根外径(mm) Makeup:total / O.D. of every wire(mm)</td> <td colspan="2">7/0.08</td> </tr> <tr> <td>(绞合)标称外径(mm) (Intertwist)NOM.O.D.(mm)</td> <td colspan="2">0.24±0.02</td> </tr> <tr> <td rowspan="3">②绝缘层 Insulation</td> <td>材料 Material</td> <td colspan="2">聚全氟乙烯 FEP</td> </tr> <tr> <td>颜色 Color</td> <td colspan="2">透明 Clarity</td> </tr> <tr> <td>标称外径(mm) NOM.O.D.(mm)</td> <td colspan="2">0.7±0.03</td> </tr> <tr> <td rowspan="4">③外导体 Outer conductor</td> <td>材料 Material</td> <td colspan="2">镀锡铜线 Tinned copper wire</td> </tr> <tr> <td>组成:总根数/单根外径(mm) Makeup:total / O.D. of every wire(mm)</td> <td colspan="2">4/0.05</td> </tr> <tr> <td>标称外径(mm) NOM.O.D.(mm)</td> <td colspan="2">0.92±0.05</td> </tr> <tr> <td>覆盖率(%) Coverage ratio(%)</td> <td colspan="2">90±5</td> </tr> <tr> <td rowspan="3">④护套层 Jacket</td> <td>材料 Material</td> <td colspan="2">聚全氟乙烯 FEP</td> </tr> <tr> <td>颜色 Color</td> <td colspan="2">灰 Gray</td> </tr> <tr> <td>标称外径(mm) NOM.O.D.(mm)</td> <td colspan="2">1.13±0.05</td> </tr> </table>	型号 Type	RF-1.13/50	料号 P/N	SY113/50-064(Gray)	结构图 Structure drawing				结构特性 Structure characteristics				结构 Structure	项目 Item	标准值 Standard value		①内导体 Inner conductor	材料 Material	镀锡铜线 Tinned copper wire		组成:总根数/单根外径(mm) Makeup:total / O.D. of every wire(mm)	7/0.08		(绞合)标称外径(mm) (Intertwist)NOM.O.D.(mm)	0.24±0.02		②绝缘层 Insulation	材料 Material	聚全氟乙烯 FEP		颜色 Color	透明 Clarity		标称外径(mm) NOM.O.D.(mm)	0.7±0.03		③外导体 Outer conductor	材料 Material	镀锡铜线 Tinned copper wire		组成:总根数/单根外径(mm) Makeup:total / O.D. of every wire(mm)	4/0.05		标称外径(mm) NOM.O.D.(mm)	0.92±0.05		覆盖率(%) Coverage ratio(%)	90±5		④护套层 Jacket	材料 Material	聚全氟乙烯 FEP		颜色 Color	灰 Gray		标称外径(mm) NOM.O.D.(mm)	1.13±0.05	
型号 Type	RF-1.13/50	料号 P/N	SY113/50-064(Gray)																																																									
结构图 Structure drawing																																																												
结构特性 Structure characteristics																																																												
结构 Structure	项目 Item	标准值 Standard value																																																										
①内导体 Inner conductor	材料 Material	镀锡铜线 Tinned copper wire																																																										
	组成:总根数/单根外径(mm) Makeup:total / O.D. of every wire(mm)	7/0.08																																																										
	(绞合)标称外径(mm) (Intertwist)NOM.O.D.(mm)	0.24±0.02																																																										
②绝缘层 Insulation	材料 Material	聚全氟乙烯 FEP																																																										
	颜色 Color	透明 Clarity																																																										
	标称外径(mm) NOM.O.D.(mm)	0.7±0.03																																																										
③外导体 Outer conductor	材料 Material	镀锡铜线 Tinned copper wire																																																										
	组成:总根数/单根外径(mm) Makeup:total / O.D. of every wire(mm)	4/0.05																																																										
	标称外径(mm) NOM.O.D.(mm)	0.92±0.05																																																										
	覆盖率(%) Coverage ratio(%)	90±5																																																										
④护套层 Jacket	材料 Material	聚全氟乙烯 FEP																																																										
	颜色 Color	灰 Gray																																																										
	标称外径(mm) NOM.O.D.(mm)	1.13±0.05																																																										

3. Structural dimension drawing (CAD drawing file)

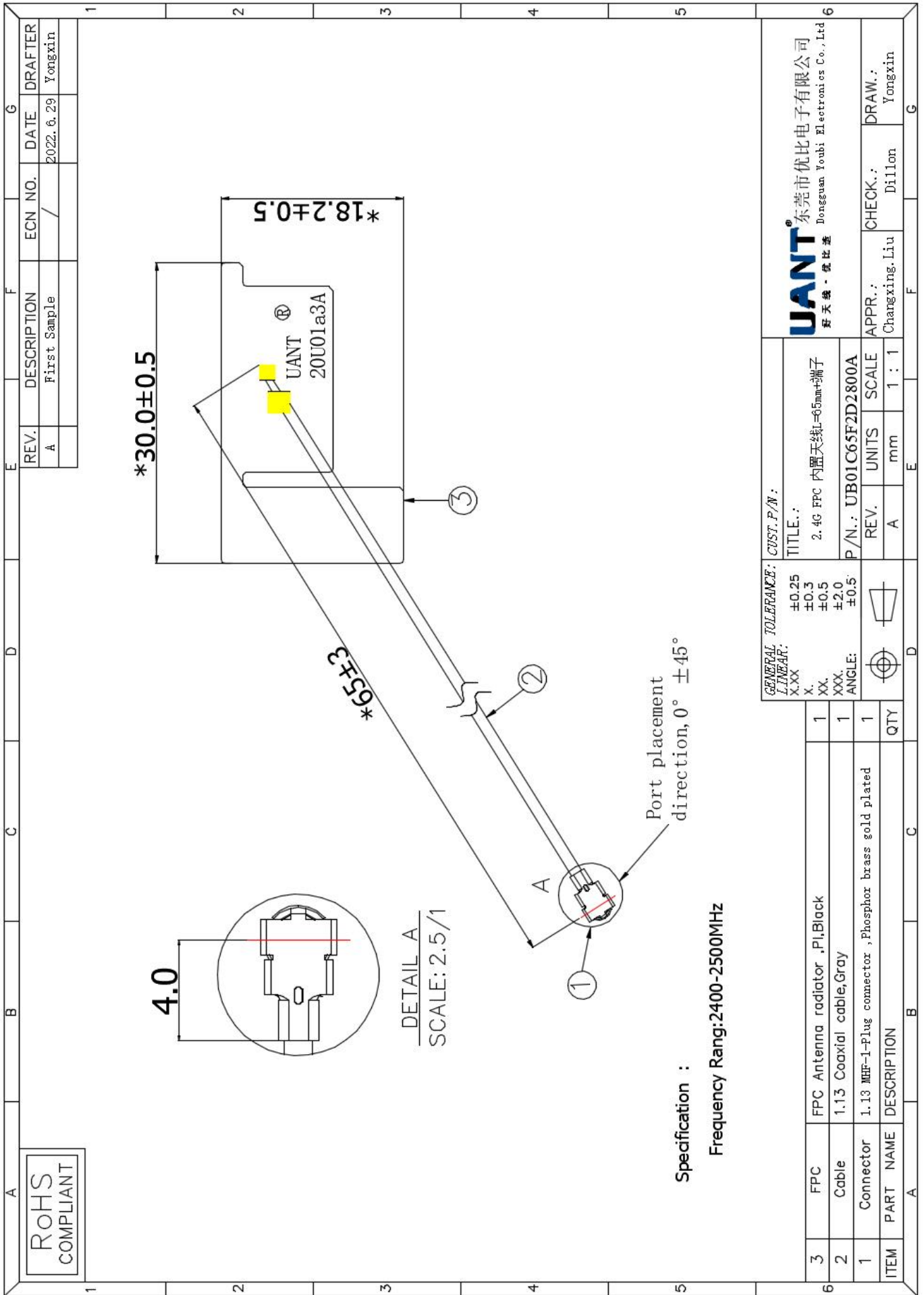



4. BOM (Bill of Materials)

No.	Part material	Material	Specifications/Models	Brand	Supplier	Dosage
1	FPC	PI	30*18.2*0.2mm	\	XG	1PCS
2	Connector	Phosphor copper plating	1.13 MHF-1-Plug	\	CM	1PCS
3	Cable	FEP/Tin plated copper	RF-1.13	\	SY	1PCS
4	PE Bag	PE	150*150*0.06mm	\	TL	1/200PCS
5	Carton	\	325*325*200*6mm	\	JLD	/

5. Packaging

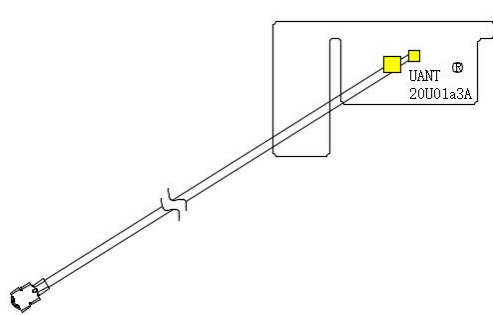
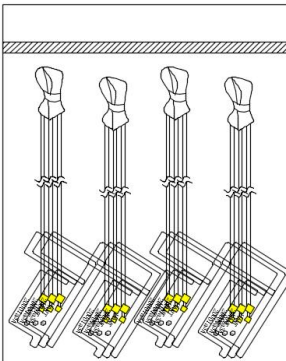
5.1. Packaging pictures:

1. Photos or pictures of single material packaging	2. Photos or pictures of the single layer of the inner packaging
 <p>Remark:</p>	 <p>Remark: 50pcs / sheaf,200PCS / PE Bag</p>
3. Photos or pictures of the outer packaging	
 <p>Remark:</p>	

【Supplier BOM code rules】 :

General process coding rules for finished products:

UB + 01 + C +65+ F + 2D + 2800 + A

① ② ③ ④ ⑤ ⑥ ⑦ ⑧

1. UB stands for antenna product.
2. Large classification of finished products: 01 is terminal built-in type;
3. Connection code: C is outgoing wire connection;
4. 65 stands for wire length
5. Material and color description: F stands for FPC;
6. Gain description: gain digital +D (DBi);
7. Serial number :1 to 9999999999;
8. Version number: The code of version A is A.

6. Production process flow chart

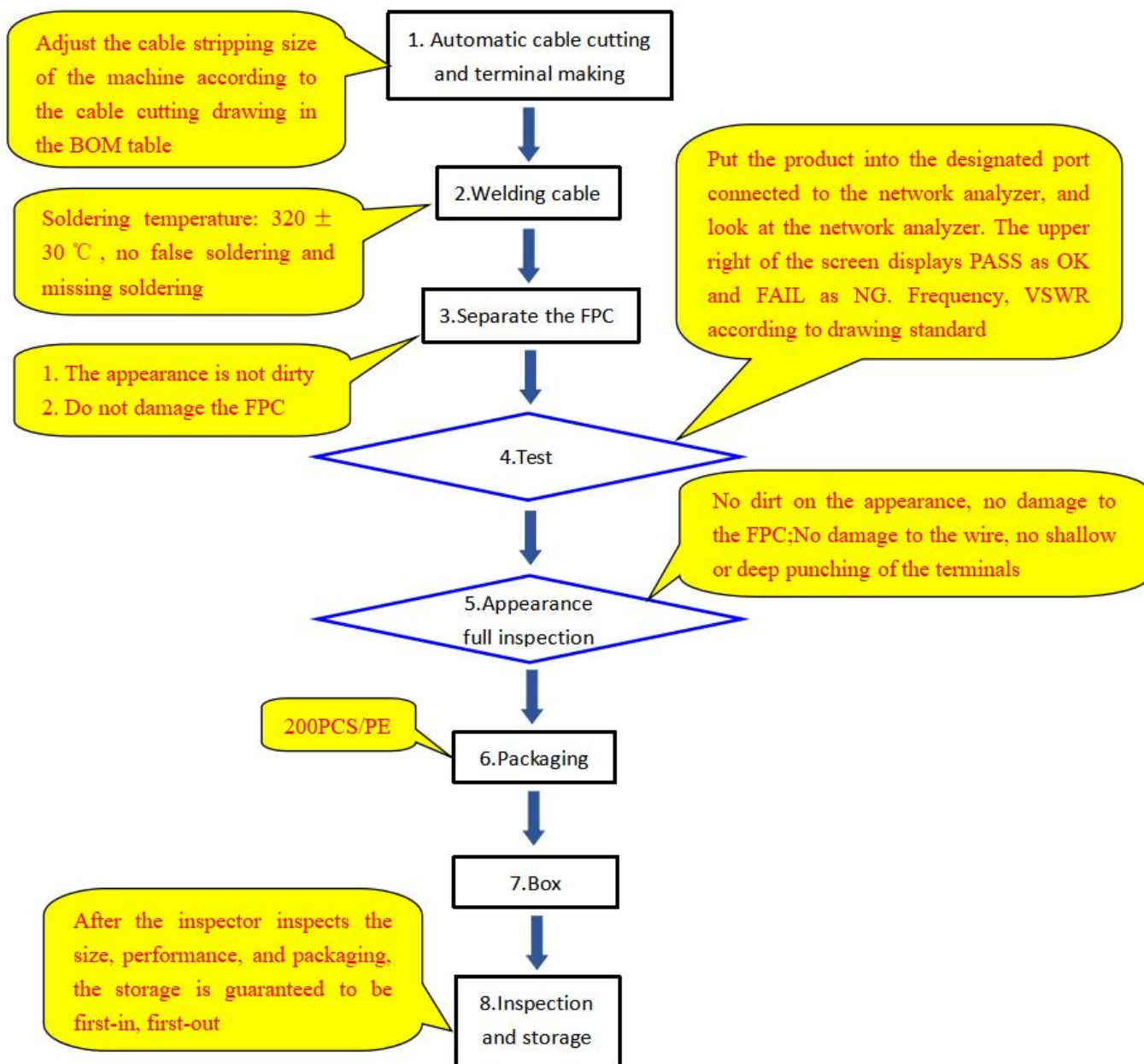

7. Certification Test Status

- UL Certification or report number: _____
- VDE Certification or report number: _____
- CE Certification or report number: _____
- FCC Certification or report number: _____
- ROHS Certification or report number: A2210015845101E
- REACH Certification or report number: _____
- EMC Certification or report number: _____
- CCC Certification or report number: _____
- SRRC Certification or report number: _____
- Other Certification or report number: _____
- No product certification

1. S Parameter

Frequency (MHz)	Return Loss(dB)	VSWR
2400	-15.97	1.37
2450	-24.78	1.12
2500	-19.15	1.24

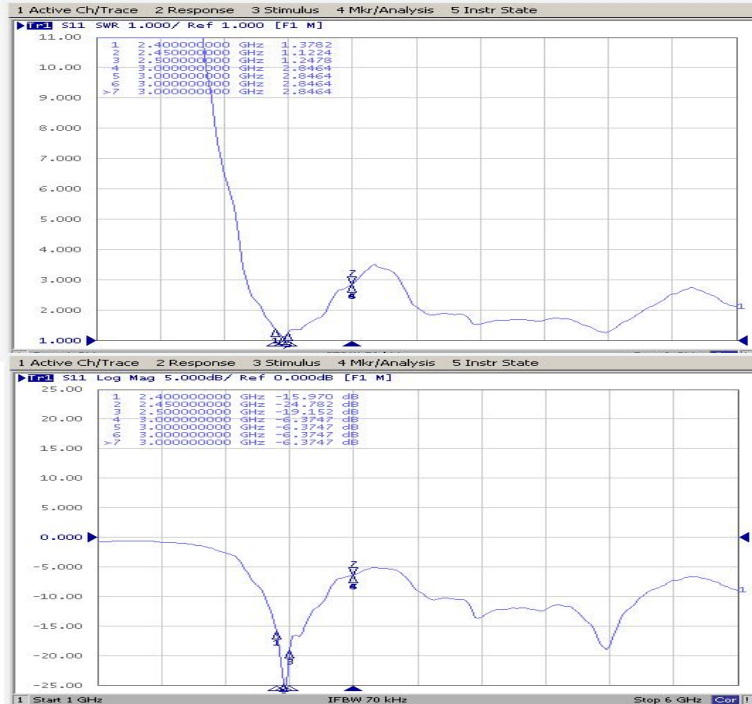

* Voltage Standing Wave Ratio(VSWR)
 Return Loss(RL)
 $RL=20*\log_{10}[(VSWR+1)/(VSWR-1)]$

2. Efficiency and Gain

Frequency (MHz)	2400	2450	2500
Efficiency (%)	55.1	53.8	52.3
Gain (dBi)	2.86	2.55	2.4

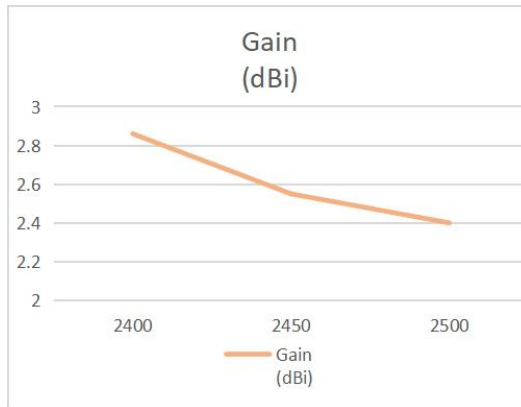
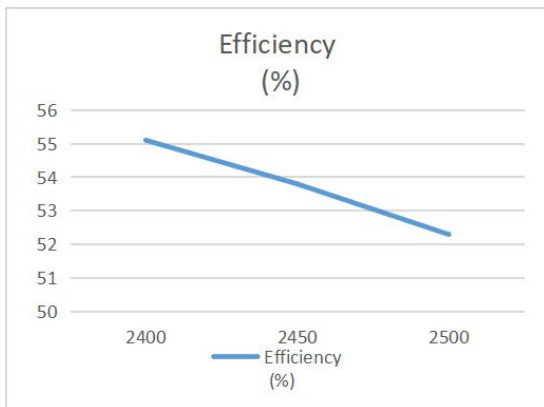

3. Radiation Pattern

3-1 Antenna 3D Radiation Pattern

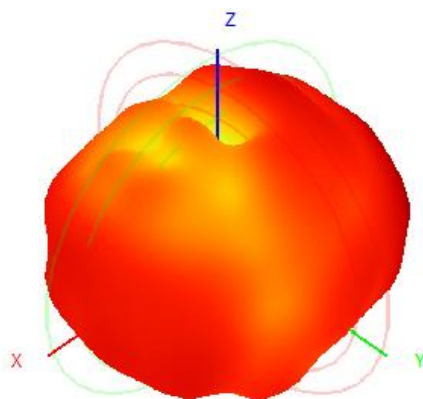

2400MHz

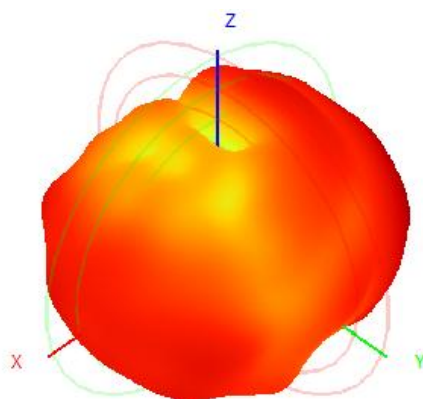

2450MHz

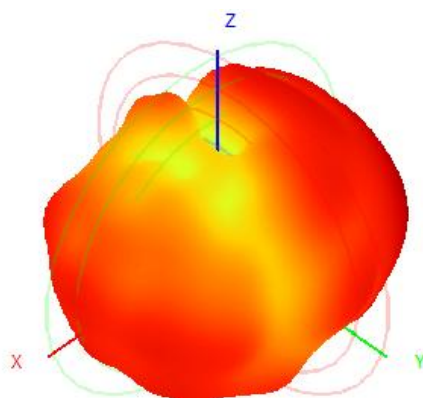

2500MHz

3-2 Antenna 2D Radiation Pattern

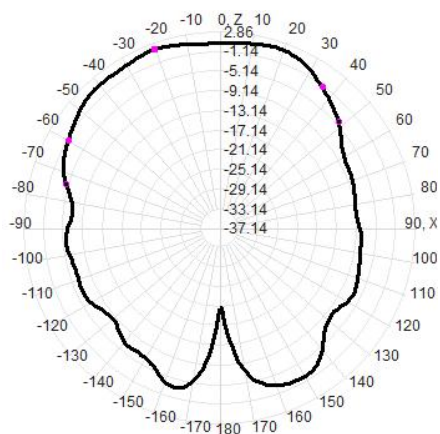

2400MHz

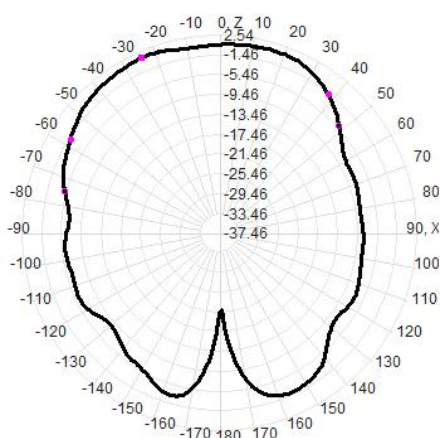

2450MHz

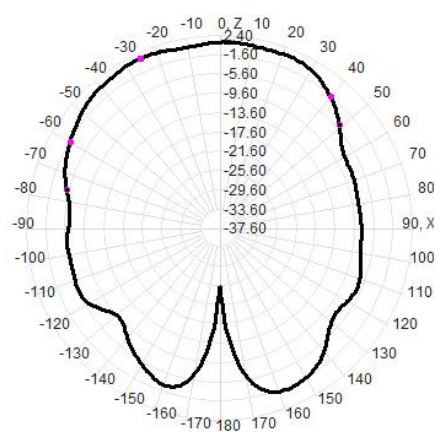

2500MHz

4. Active test data

Item	Measurement	Total
1	TRP	17.57
6	TRP	17.3
11	TRP	18.37
1	TIS(EIRP)	-89.29
6	TIS(EIRP)	-89.03
11	TIS(EIRP)	-88.49

5. Antenna Matching Network

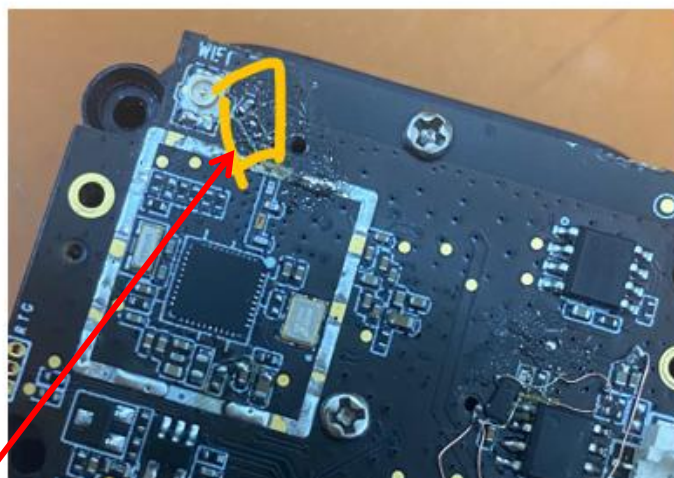
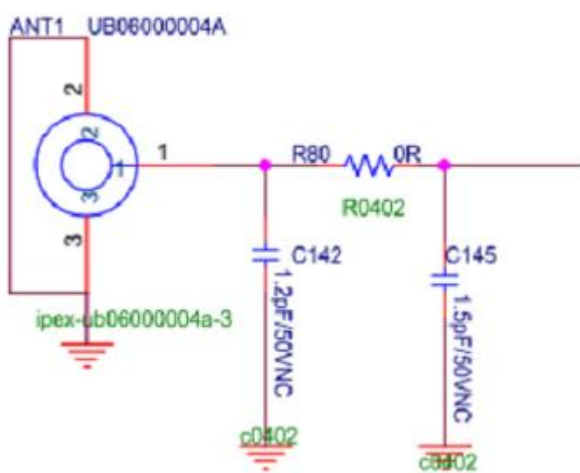

C145	NC
C142	Shunt 1pF
R80	Series 0Ω

6. Antenna installation diagram

