

FCC Part 15 B Test Report
On Behalf of
Shenzhen Loyal Electronics Co., Ltd.

Dongle
Model No.: KG8004

Prepared for : Shenzhen Loyal Electronics Co., Ltd.
Address : 8F, Bldg. A, Huayuan Technology Park, Fenghuang Industrial
Zone, Fuyong, Bao'an, Shenzhen

Prepared By : Anbotek Compliance Laboratory Limited
Address : 1/F, 1/Build, SEC Industrial Park, No. 4 Qianhai Road, Nanshan
District, Shenzhen, 518054, China
Tel: (86) 755-26014771
Fax: (86) 755-26014772

Report Number : 201110673F-1
Date of Test : Oct. 12~Oct. 17, 2011
Date of Report : Oct. 18, 2011

TABLE OF CONTENTS

Description

Page

Test Report Verification

1. GENERAL INFORMATION	4
1.1. Description of Device (EUT)	4
1.2. Auxiliary Equipment Used during Test	5
1.3. Description of Test Facility	6
1.4. Measurement Uncertainty	6
1.5. Test Summary	6
2. POWER LINE CONDUCTED MEASUREMENT	7
2.1. Test Equipment	7
2.2. Block Diagram of Test Setup	7
2.3. Power Line Conducted Emission Measurement Limits (FCC Part 15 Subpart B Class B)	7
2.4. Configuration of EUT on Measurement	7
2.5. Operating Condition of EUT	8
2.6. Test Procedure	8
2.7. Power Line Conducted Emission Measurement Results	8
3. RADIATED EMISSION MEASUREMENT	11
3.1. Test Equipment	11
3.2. Block Diagram of Test Setup	11
3.3. Radiated Emission Limit (Subpart B Class B)	11
3.4. EUT Configuration on Measurement	12
3.5. Operating Condition of EUT	12
3.6. Test Procedure	12
3.7. Radiated Emission Measurement Results	12
4. PHOTOGRAPH	15
4.1. Photo of Power Line Conducted Emission Test	15
4.2. Photo of Radiated Emission Test	15

APPENDIX I (Photos of EUT) (4 Pages)

TEST REPORT VERIFICATION

Applicant : Shenzhen Loyal Electronics Co., Ltd.
 Manufacturer : Shenzhen Loyal Electronics Co., Ltd.
 EUT : Dongle
 Model No. : KG8004
 Rating : 5V \pm , 50mA max.
 Trade Mark : N.A.

Measurement Procedure Used:

FCC Rules and Regulations Part 15 Subpart B 2010 & FCC / ANSI C63.4-2009

The device described above is tested by Anbotek Compliance Laboratory Limited To determine the maximum emission levels emanating from the device. The maximum emission levels are compared to the FCC Part 15 Subpart B Class B limits both radiated and conducted emissions. The measurement results are contained in this test report and Anbotek Compliance Laboratory Limited Is assumed full responsibility for the accuracy and completeness of these measurements. Also, this report shows that the Equipment Under Test (EUT) is to be technically compliant with the FCC requirements.

This report applies to above tested sample only. This report shall not be reproduced in part without written approval of Anbotek Compliance Laboratory Limited

Date of Test : Oct. 12~Oct. 17, 2011

Prepared by : 
(Engineer/ Heise Chen)

Reviewer : 
(Project Manager/ Yoyo Zhu)

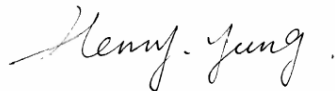
Approved & Authorized Signer : 
(Manager/ Henry Yang)

1. GENERAL INFORMATION

1.1. Description of Device (EUT)

Description : Dongle

Model Number : KG8004

Test Power Supply : DC 5V

Applicant : Shenzhen Loyal Electronics Co., Ltd.

Address : 8F, Bldg. A, Huayuan Technology Park, Fenghuang
Industrial Zone, Fuyong, Bao'an, Shenzhen

Manufacturer : Shenzhen Loyal Electronics Co., Ltd.

Address : 8F, Bldg. A, Huayuan Technology Park, Fenghuang
Industrial Zone, Fuyong, Bao'an, Shenzhen

Date of Sample received : Oct. 11, 2011

Date of Test : Oct. 12~Oct. 17, 2011

1.2. Auxiliary Equipment Used during Test

PC	: Manufacturer: DELL M/N: OPTIPLEX 380 S/N: 1J63X2X CE , FCC: DOC
MONITOR	: Manufacturer: DELL M/N: E170Sc S/N: CN-00V539-64180-055-0UPS CE , FCC: DOC
KEYBOARD	: Manufacturer: DELL M/N: SK-8115 S/N: CN-0DJ313-71616-06C-02XN CE , FCC: DOC Cable: 1m, unshielded
Printer	: Manufacturer: Brother M/N: MFC-3360C S/N: N/A CE, FCC: DOC
Power Line	: Non-Shielded, 1.5m
VGA Cable	: Non-Shielded, 1.5m

1.3. Description of Test Facility

The test facility is recognized, certified, or accredited by the following organizations:

CNAS - LAB Code: L3503

Anbotek Compliance Laboratory Limited., Laboratory has been assessed and in compliance with CNAS/CL01: 2006 accreditation criteria for testing laboratories (identical to ISO/IEC 17025: 2005 General Requirements) for the Competence of Testing Laboratories.

FCC-Registration No.: 752021

Anbotek Compliance Laboratory Limited, EMC Laboratory has been registered and fully described in a report filed with the (FCC) Federal Communications Commission. The acceptance letter from the FCC is maintained in our files. Registration 752021, August 20, 2010

IC-Registration No.: 8058A-1

Anbotek Compliance Laboratory Limited., EMC Laboratory has been registered and fully described in a report filed with the (IC) Industry Canada. The acceptance letter from the IC is maintained in our files. Registration 8058A-1, August 30, 2010

Test Location

All Emissions tests were performed

Anbotek Compliance Laboratory Limited. at 1/F, 1/Build, SEC Industrial Park, No. 4 Qianhai Road, Nanshan District, Shenzhen, 518054, China

1.4. Measurement Uncertainty

Radiation Uncertainty : Ur = 4.3dB

Conduction Uncertainty : Uc = 3.4dB

1.5. Test Summary

For the EUT described above. The standards used were FCC Part 15 Subpart B for Emissions.

Table 1 : Tests Carried Out Under FCC Part 15 Subpart B

Standard	Test Items	Status
FCC Part 15 Subpart B	Power Line Conducted Emission Test (150KHz To 30MHz)	√
FCC Part 15 Subpart B	Radiated Emission Test (30MHz To 1000MHz)	√

√ Indicates that the test is applicable

x Indicates that the test is not applicable

2. POWER LINE CONDUCTED MEASUREMENT

2.1. Test Equipment

The following test equipments are used during the power line conducted measurement:

Item	Equipment	Manufacturer	Model No.	Serial No.	Last Cal.	Cal. Interval
1.	EMI Receiver	Rohde & Schwarz	ESCI	100627	Nov. 12, 2010	1 Year
2.	Two-Line V-network	Rohde & Schwarz	ENV216	10055	May 19, 2011	1 Year
3.	RF Switching Unit	Compliance Direction	RSU-M2	38303	May 19, 2011	1 Year
4.	EMI Test Software	ES-K1	N/A	N/A	N/A	N/A

2.2. Block Diagram of Test Setup

2.2.1. Block diagram of connection between the EUT and simulators

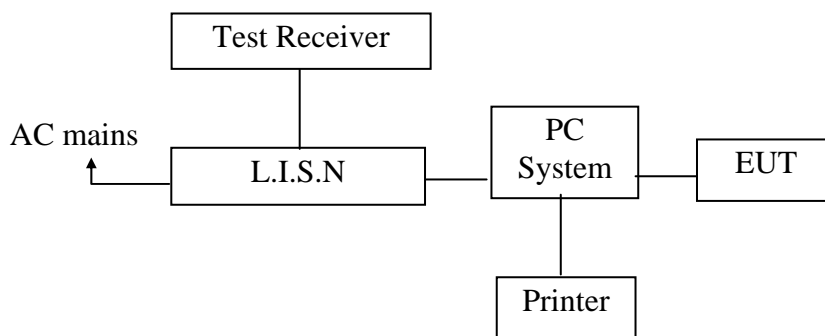

(EUT: Dongle)

2.3. Power Line Conducted Emission Measurement Limits (FCC Part 15 Subpart B Class B)

Frequency MHz	Limits dB(μV)	
	Quasi-peak Level	Average Level
0.15 ~ 0.50	66 ~ 56*	56 ~ 46*
0.50 ~ 5.00	56	46
5.00 ~ 30.00	60	50

Notes: 1. *Decreasing linearly with logarithm of frequency.

2.3.1. The lower limit shall apply at the transition frequencies.

2.4. Configuration of EUT on Measurement

The following equipments are installed on Power Line Conducted Emission Measurement to meet the commission requirement and operating regulations in a

manner which tends to maximize its emission characteristics in a normal application.

EUT : Dongle
Model Number : KG8004
Applicant : Shenzhen Loyal Electronics Co., Ltd.

2.5. Operating Condition of EUT

- 2.5.1. Setup the EUT and simulator as shown as Section 2.2.
- 2.5.2. Turn on the power of all equipment.
- 2.5.3. Let the EUT work in test mode (On) and measure it.

2.6. Test Procedure

The EUT system is connected to the power mains through a line impedance stabilization network (L.I.S.N.). This provides a 50ohm coupling impedance for the EUT system. Please refer the block diagram of the test setup and photographs. Both sides of AC line are checked to find out the maximum conducted emission. In order to find the maximum emission levels, the relative positions of equipment and all of the interface cables shall be changed according to FCC ANSI C63.4-2009 on Conducted Emission Measurement.

The bandwidth of test receiver (ESCI) set at 9KHz.
The frequency range from 150KHz to 30MHz is checked.
The test result are reported on Section 2.7.

2.7. Power Line Conducted Emission Measurement Results

PASS.

The frequency range from 150KHz to 30 MHz is investigated.
The test curves are shown in the following pages.

FCC ID: Z5X8004RX

CONDUCTED EMISSION TEST DATA

EUT: Dongle M/N: KG8004
 Operating Condition: ON
 Test Site: 1# Shielded Room
 Operator: Heise Chen
 Test Specification: 120V~, 60Hz for Adapter
 Comment: Live Line
 Tem:22.2 Hum:60%

SCAN TABLE: "Voltage (150K~30M) FIN"

Short Description: 150K-30M Disturbance Voltages

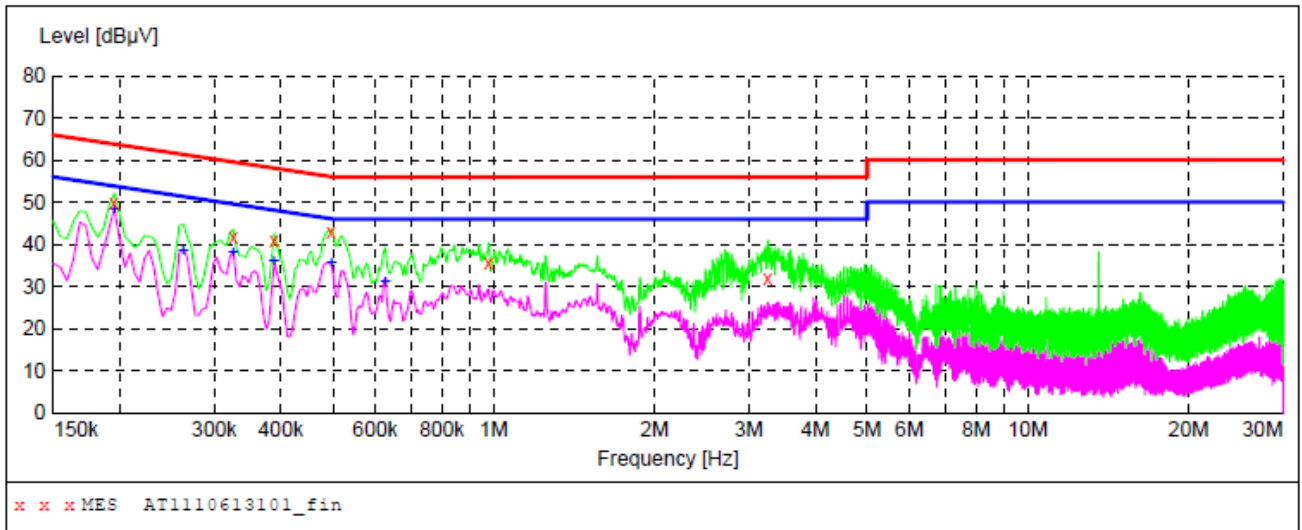

MEASUREMENT RESULT: "AT1110613101_fin"

10/12/2011 11:09AM

Frequency MHz	Level dBµV	Transd dB	Limit dBµV	Margin dB	Detector	Line	PE
0.195000	50.10	10.1	64	13.7	QP	L1	GND
0.325500	41.80	10.1	60	17.8	QP	L1	GND
0.388500	40.90	10.1	58	17.2	QP	L1	GND
0.496500	42.90	10.1	56	13.2	QP	L1	GND
0.978000	35.70	10.2	56	20.3	QP	L1	GND
3.254500	31.80	10.4	56	24.2	QP	L1	GND

MEASUREMENT RESULT: "AT1110613101_fin2"

10/12/2011 11:09AM

Frequency MHz	Level dBµV	Transd dB	Limit dBµV	Margin dB	Detector	Line	PE
0.195000	48.40	10.1	54	5.4	AV	L1	GND
0.262500	38.50	10.1	51	12.9	AV	L1	GND
0.325500	38.00	10.1	50	11.6	AV	L1	GND
0.388500	35.90	10.1	48	12.2	AV	L1	GND
0.496500	35.60	10.1	46	10.5	AV	L1	GND
0.627000	31.20	10.1	46	14.8	AV	L1	GND

CONDUCTED EMISSION TEST DATA

EUT: Dongle M/N: KG8004
 Operating Condition: ON
 Test Site: 1# Shielded Room
 Operator: Heise Chen
 Test Specification: 120V~, 60Hz for Adapter
 Comment: Neutral Line
 Tem:22.2 Hum:60%

SCAN TABLE: "Voltage (150K~30M) FIN"

Short Description: 150K-30M Disturbance Voltages

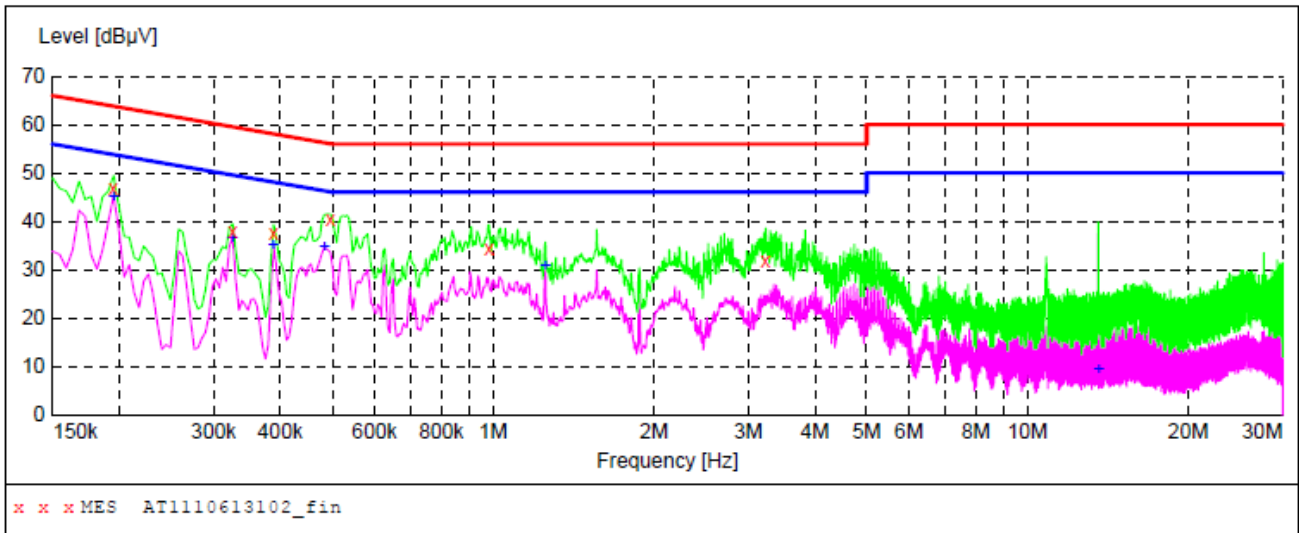

MEASUREMENT RESULT: "AT1110613102_fin"

10/12/2011 11:14AM

Frequency MHz	Level dBµV	Transd dB	Limit dBµV	Margin dB	Detector	Line	PE
0.195000	47.00	10.1	64	16.8	QP	N	GND
0.325500	38.00	10.1	60	21.6	QP	N	GND
0.388500	37.70	10.1	58	20.4	QP	N	GND
0.496500	40.60	10.1	56	15.5	QP	N	GND
0.982500	34.50	10.2	56	21.5	QP	N	GND
3.236500	31.90	10.4	56	24.1	QP	N	GND

MEASUREMENT RESULT: "AT1110613102_fin2"

10/12/2011 11:14AM

Frequency MHz	Level dBµV	Transd dB	Limit dBµV	Margin dB	Detector	Line	PE
0.195000	45.00	10.1	54	8.8	AV	N	GND
0.325500	36.50	10.1	50	13.1	AV	N	GND
0.388500	34.90	10.1	48	13.2	AV	N	GND
0.483000	34.60	10.1	46	11.7	AV	N	GND
1.252000	30.70	10.2	46	15.3	AV	N	GND
13.559500	9.40	10.7	50	40.6	AV	N	GND

3. RADIATED EMISSION MEASUREMENT

3.1. Test Equipment

The following test equipments are used during the radiated emission measurement:

3.1.1. For Anechoic Chamber

Item	Equipment	Manufacturer	Model No.	Serial No.	Last Cal.	Cal. Interval
1.	EMI Test Receiver	Rohde & Schwarz	ESCI	100627	Nov. 12, 2011	1 Year
2.	Bilog Broadband Antenna	Schwarzbeck	VULB9163	100015	May 17, 2011	1 Year
3.	RF Switching Unit	Compliance Direction	RSU-M2	38303	May 19, 2011	1 Year
4.	EMI Test Software	ES-K1	N/A	N/A	N/A	N/A

3.2. Block Diagram of Test Setup

3.2.1. Block diagram of connection between the EUT and simulators

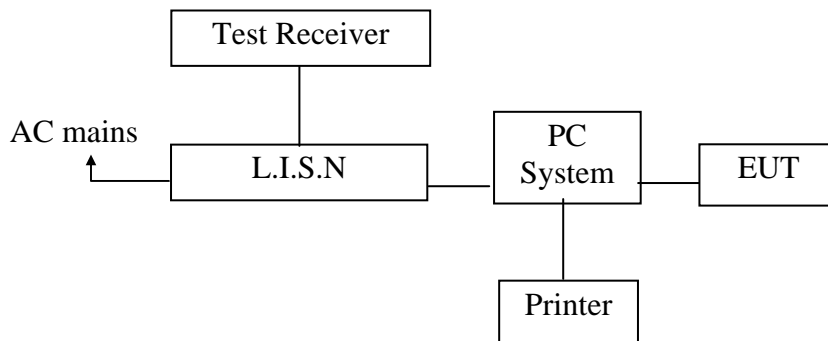

(EUT: Dongle)

3.2.2. Anechoic Chamber Test Setup Diagram

ANTENNA TOWER

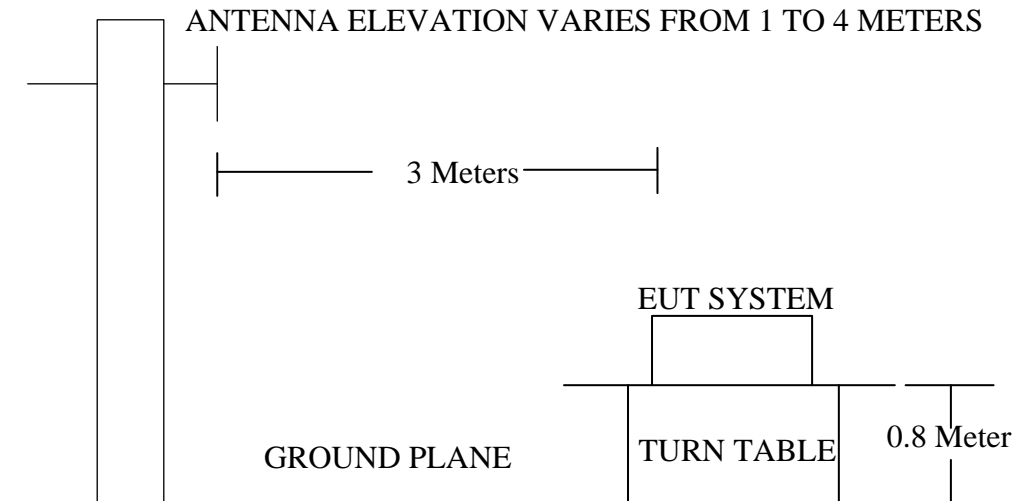

(EUT: Digital Photo Frame)

3.3. Radiated Emission Limit (Subpart B Class B)

FREQUENCY	DISTANCE	FIELD STRENGTHS LIMIT
-----------	----------	-----------------------

MHz	Meters	$\mu\text{V}/\text{m}$	$\text{dB}(\mu\text{V})/\text{m}$
30~88	3	100	40.0
88~216	3	150	43.5
216~960	3	200	46.0
960~1000	3	500	54.0

- Remark :
- (1) Emission level $(\text{dB})\mu\text{V} = 20 \log \text{Emission level } \mu\text{V}/\text{m}$
 - (2) The smaller limit shall apply at the cross point between two frequency bands.
 - (3) Distance is the distance in meters between the measuring instrument, antenna and the closest point of any part of the device or system.

3.4. EUT Configuration on Measurement

The following equipments are installed on Radiated Emission Measurement to meet the commission requirements and operating regulations in a manner which tends to maximize its emission characteristics in normal application.

EUT : Dongle
 Model Number : KG8004
 Applicant : Shenzhen Loyal Electronics Co., Ltd.

3.5. Operating Condition of EUT

- 3.5.1. Setup the EUT as shown in Section 3.2.
- 3.5.2. Let the EUT work in test mode (On) and measure it.

3.6. Test Procedure

EUT and its simulators are placed on a turn table, which is 0.8 meter high above ground. The turn table can rotate 360 degrees to determine the position of the maximum emission level. EUT is set 3.0 meters away from the receiving antenna, which is mounted on a antenna tower. The antenna can be moved up and down between 1.0 meter and 4 meters to find out the maximum emission level. Broadband antenna (Trilog Broadband Antenna) is used as receiving antenna. Both horizontal and vertical polarizations of the antenna are set on measurement. In order to find the maximum emission levels, all of the interface cables must be manipulated according to ANSI C63.4-2009 on radiated emission measurement.

The bandwidth of the EMI test receiver (ESCI) is set at 120kHz.

The frequency range from 30MHz to 1000MHz is checked.

The test mode (On) is tested in chamber and all the test results are listed in Section 3.7.

3.7. Radiated Emission Measurement Results

PASS.

The test curves are shown in the following pages.



Anbotek Compliance Laboratory Limited

1/F, 1 /Building, SEC Industrial Park, No.4 Qianhai Road,
Nanshan District, Shenzhen, 518054, China

Tel: (86)755-26014771
Fax: (86)755-26014772
Http://www.anbotek.com

Job No.:	AT1110613F-1	Polarization:	Horizontal
Standard:	(RE)FCC PART15 B _3m	Power Source:	DC 5V
Test item:	Radiation Test	Date:	2011/10/12
Temp.(C)/Hum.(%RH):	24.3(C)/55%RH	Time:	22:22:29
EUT:	Dongle	Test By:	Heise Chen
Model:	KG8004	Distance:	3m
Note:	On		

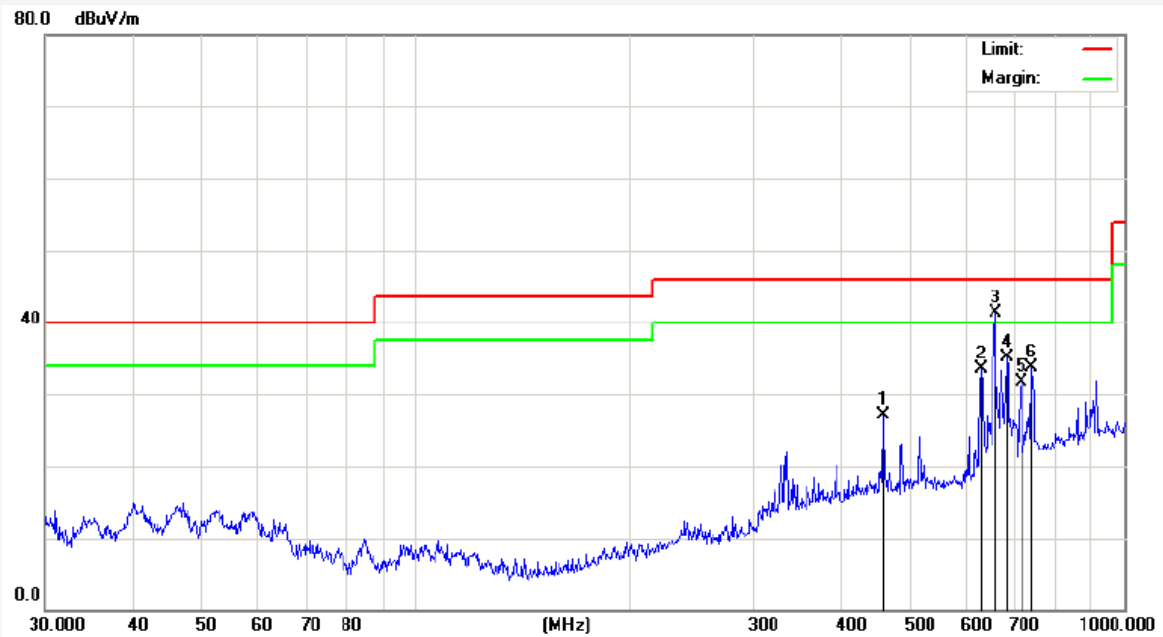

No.	Freq. (MHz)	Reading (dBuV/m)	Factor (dB/m)	Result (dBuV/m)	Limit (dBuV/)	Over Limit (dB)	Detector	Height (cm)	degree (deg)	Remark
1	455.9058	47.74	-20.55	27.19	46.00	-18.81	peak			
2	627.2738	51.19	-17.78	33.41	46.00	-12.59	peak			
3	656.5300	58.21	-16.83	41.38	46.00	-4.62	QP	300	0	
4	682.3484	51.19	-16.00	35.19	46.00	-10.81	peak			
5	714.1734	46.82	-15.16	31.66	46.00	-14.34	peak			
6	739.6604	48.43	-14.69	33.74	46.00	-12.26	peak			



Anbotek Compliance Laboratory Limited

1/F, 1 /Building, SEC Industrial Park, No.4 Qianhai Road,
Nanshan District, Shenzhen, 518054, China

Tel: (86)755-26014771
Fax: (86)755-26014772
Http://www.anbotek.com

Job No.:	AT1110613F-1	Polarziation:	Vertical
Standard:	(RE)FCC PART15 B _3m	Power Source:	DC 5V
Test item:	Radiation Test	Date:	2011/10/12
Temp.(C)/Hum.(%RH):	24.3(C)/55%RH	Time:	22:21:02
EUT:	Dongle	Test By:	Heise Chen
Model:	KG8004	Distance:	3m

Note: On

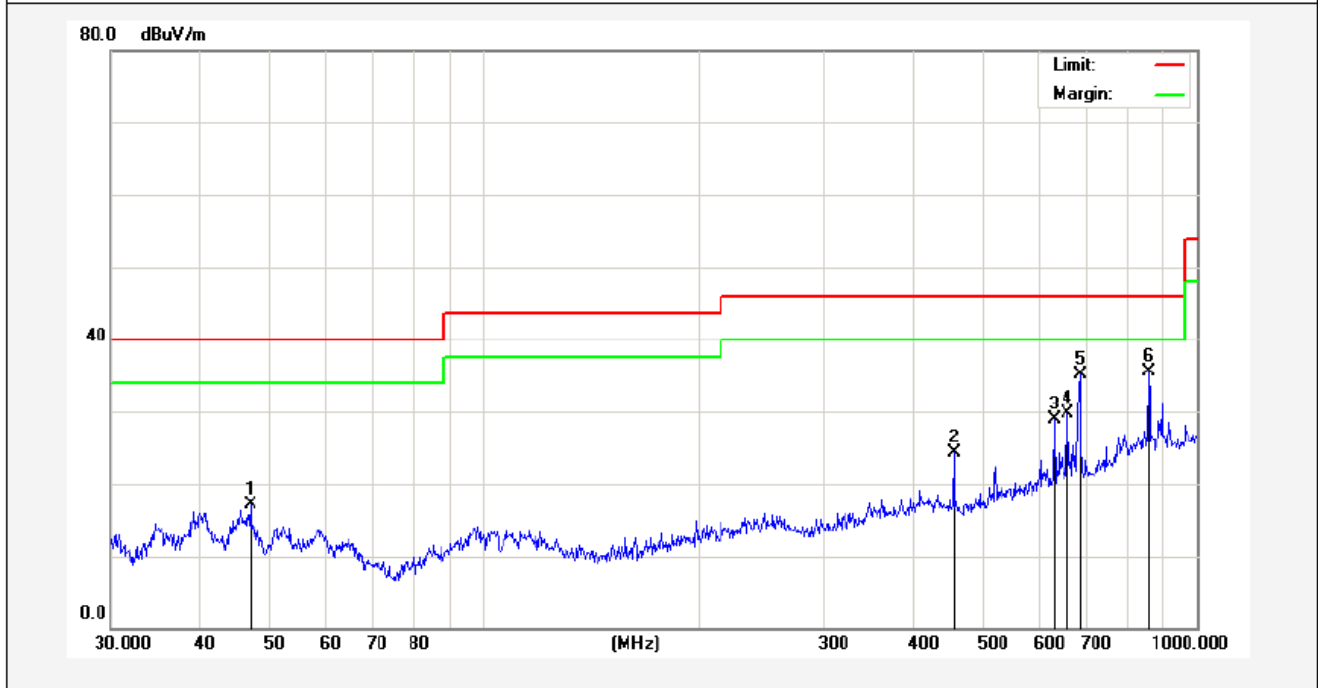

No.	Freq. (MHz)	Reading (dBuV/m)	Factor (dB/m)	Result (dBuV/m)	Limit (dBuV/)	Over Limit (dB)	Detector	Height (cm)	degree (deg)	Remark
1	46.9948	41.92	-24.81	17.11	40.00	-22.89	peak			
2	455.9058	44.58	-20.34	24.24	46.00	-21.76	peak			
3	629.4772	45.19	-16.29	28.90	46.00	-17.10	peak			
4	656.5300	45.74	-15.96	29.78	46.00	-16.22	peak			
5	684.7454	50.80	-15.61	35.19	46.00	-10.81	peak			
6	854.0247	47.10	-11.52	35.58	46.00	-10.42	peak			

4. PHOTOGRAPH

4.1. Photo of Power Line Conducted Emission Test



4.2. Photo of Radiated Emission Test



APPENDIX I (Photos of EUT)

Figure 1
The EUT- Front View



Figure 2
The EUT- Back View

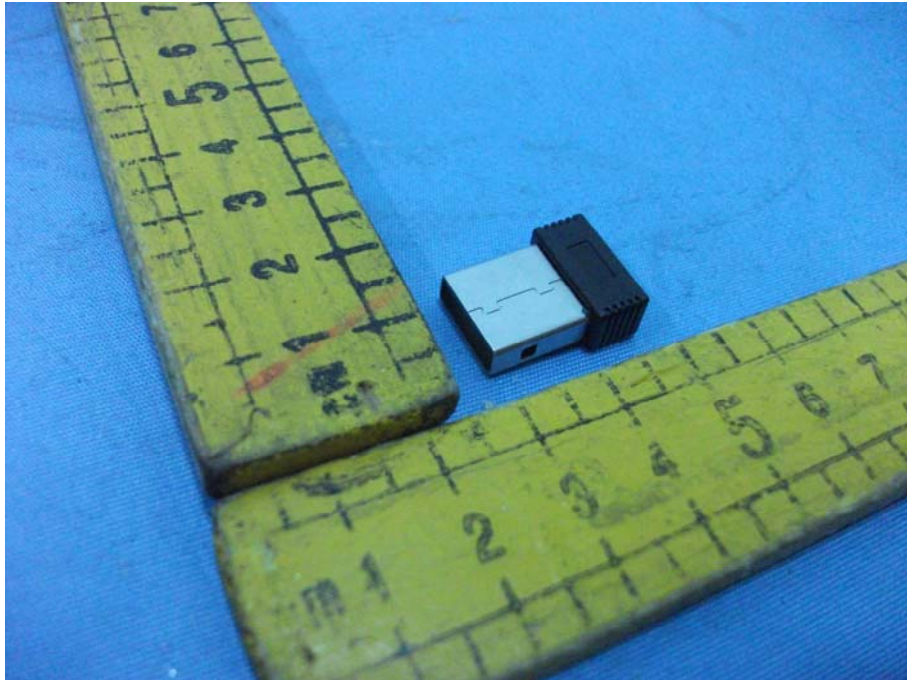

Figure 3
The EUT-Side View



Figure 4
The EUT-Inside View

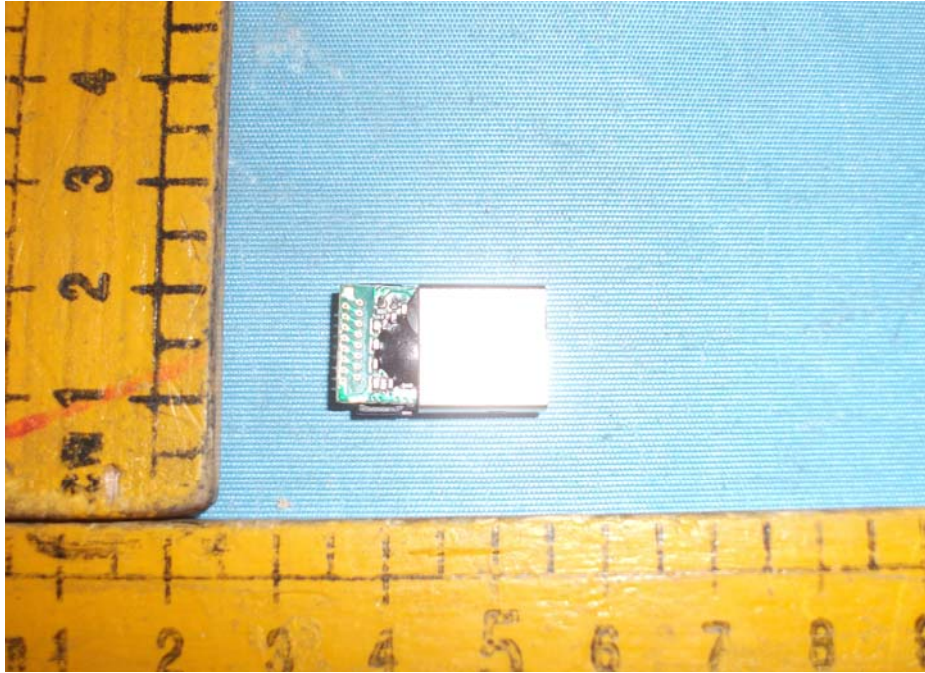

Figure 5
PCB of the EUT-Front View

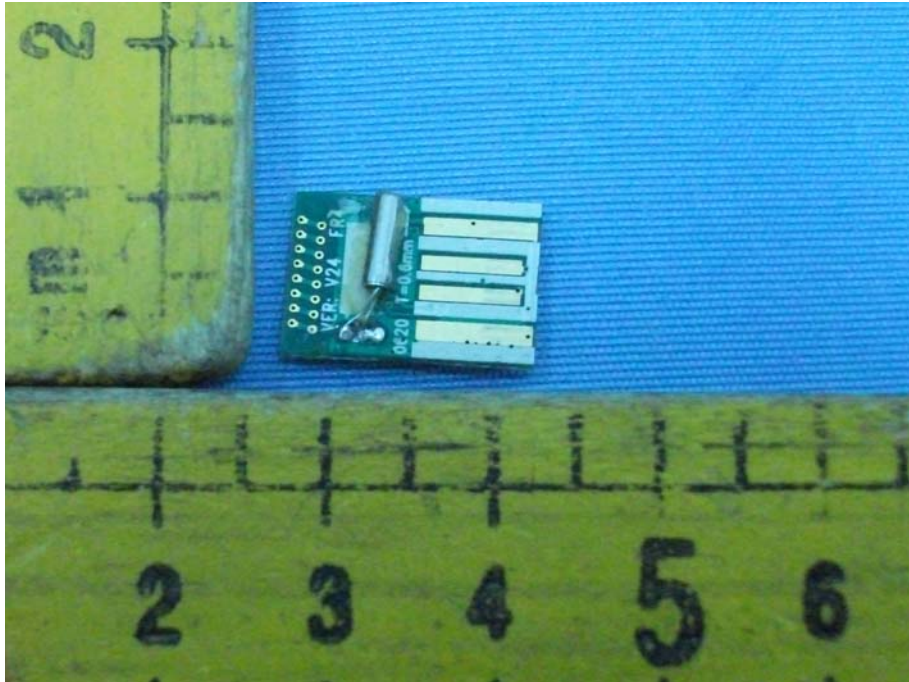

Figure 6
PCB of the EUT-Back View

