



849 NW STATE ROAD 45
NEWBERRY, FL 32669 USA
PH: 888.472.2424 OR 352.472.5500
FAX: 352.472.2030
EMAIL: INFO@TIMCOENGR.COM
[HTTP://WWW.TIMCOENGR.COM](http://WWW.TIMCOENGR.COM)

FCC PART 90 AND IC RSS-119, RSS-GEN TEST REPORT

APPLICANT	DAMM CELLULAR SYSTEMS A/S
	MOLLEGADE 68 6400 SONDERBORG DENMARK
FCC ID	Z5W-104018
IC CERTIFICATION	10159A-104018
MODEL NUMBER	TR412-800
PRODUCT DESCRIPTION	800 MHz Transceiver
DATE SAMPLE RECEIVED	12/12/2011
DATE TESTED	1/17/2012
TESTED BY	Joe Scoglio
APPROVED BY	Mario R. de Aranzeta
TIMCO REPORT NO.	2916MT11TestReport.doc
TEST RESULTS	<input checked="" type="checkbox"/> PASS <input type="checkbox"/> FAIL

**THE ATTACHED REPORT SHALL NOT BE REPRODUCED EXCEPT IN FULL
WITHOUT THE WRITTEN APPROVAL OF TIMCO ENGINEERING, INC.**



Testing Certificate #0955-01



TABLE OF CONTENTS

GENERAL REMARKS.....	3
GENERAL INFORMATION.....	4
GENERAL INFORMATION (cont'd).....	5
GENERAL INFORMATION (cont'd).....	6
TEST PROCEDURES	7
RF POWER OUTPUT.....	8
MODULATION CHARACTERISTICS.....	9
AUDIO FREQUENCY RESPONSE.....	10
AUDIO LOW PASS FILTER.....	10
AUDIO INPUT VERSUS MODULATION.....	10
OCCUPIED BANDWIDTH.....	11
SPURIOUS EMISSIONS AT ANTENNA TERMINALS (CONDUCTED).....	17
FIELD STRENGTH OF SPURIOUS EMISSIONS.....	19
TRANSIENT FREQUENCY BEHAVIOR.....	21
EMC EQUIPMENT LIST	23
FREQUENCY STABILITY.....	24

Applicant: DAMM CELLULAR SYSTEMS A/S
FCC ID: Z5W-104018
IC CERT #: 10159A-104018
Report: D\DAMM\2916MT11\2916MT11TestReport.doc

GENERAL REMARKS

The attached report shall not be reproduced except in full without the written permission of Timco Engineering Inc.

The test results relate only to the items tested.

Summary

The device under test does:

- fulfill the general approval requirements as identified in this test report
- not fulfill the general approval requirements as identified in this test report

Attestations

This equipment has been tested in accordance with the standards identified in this test report. To the best of my knowledge and belief, these tests were performed using the measurement procedures described in this report.

All instrumentation and accessories used to test products for compliance to the indicated standards are calibrated regularly in accordance with ISO 17025: 2005 requirements.



Testing Certificate # 0955-01

I attest that the necessary measurements were made, under my supervision, at:

Timco Engineering Inc.
849 NW State Road 45
Newberry, Fl 32669



Authorized Signatory Name:

Mario de Aranzeta C.E.T.
Compliance Engineer/ Lab. Supervisor

Date: May 2, 2012

Applicant: DAMM CELLULAR SYSTEMS A/S
FCC ID: Z5W-104018
IC CERT #: 10159A-104018
Report: D\DAMM\2916MT11\2916MT11TestReport.doc

GENERAL INFORMATION
DUT Specification

DUT Description	Transceiver 0.2(modified) and 0.35 TETRA
FCC ID	Z5W-104018
IC Certification	10159A-104018
Model Number	TR412 transceiver 800MHz
Serial Number	N/A
Operating Frequency	RX = 805 – 825 TX = 850 – 869 (0.2 modified)
	862 – 869 (0.35 TETRA)
Test Frequencies	856 MHz, 863 MHz, 869 MHz
Type of Emission	21K0D1W, 21K0D1D, 21K0D1E, 21K0D7W 20K0D1W, 20K0D1D, 20K0D1E, 20K0D7W
Modulation	0.35 TETRA, 0.20 modified TETRA
DUT Power Source	<input checked="" type="checkbox"/> 110–120Vac/50– 60Hz
	<input type="checkbox"/> DC Power 12V
	<input type="checkbox"/> Battery Operated Exclusively
Test Item	<input type="checkbox"/> Prototype
	<input checked="" type="checkbox"/> Pre-Production
	<input type="checkbox"/> Production
Type of Equipment	<input checked="" type="checkbox"/> Fixed
	<input type="checkbox"/> Mobile
	<input type="checkbox"/> Portable
Test Conditions	Temperature was 26°C Relative humidity of 50%.
Modification to the DUT	None
Test Exercise	The DUT was placed in continuous transmit mode.
Applicable Standards	ANSI/TIA 603-C:2004, FCC CFR 47 Part 90, IC RSS-119, RSS-GEN
Test Facility	Timco Engineering Inc. at 849 NW State Road 45 Newberry, FL 32669 USA.

Applicant: DAMM CELLULAR SYSTEMS A/S
 FCC ID: Z5W-104018
 IC CERT #: 10159A-104018
 Report: D\DAMM\2916MT11\2916MT11TestReport.doc

GENERAL INFORMATION (cont'd)
DUT Specification

The system as tested consists of the transceiver module combined with a power supply module, CPU module, and broadband filter assembly. This is combined in a single 19inch rack assembly. The unit is detailed in the user's manual.

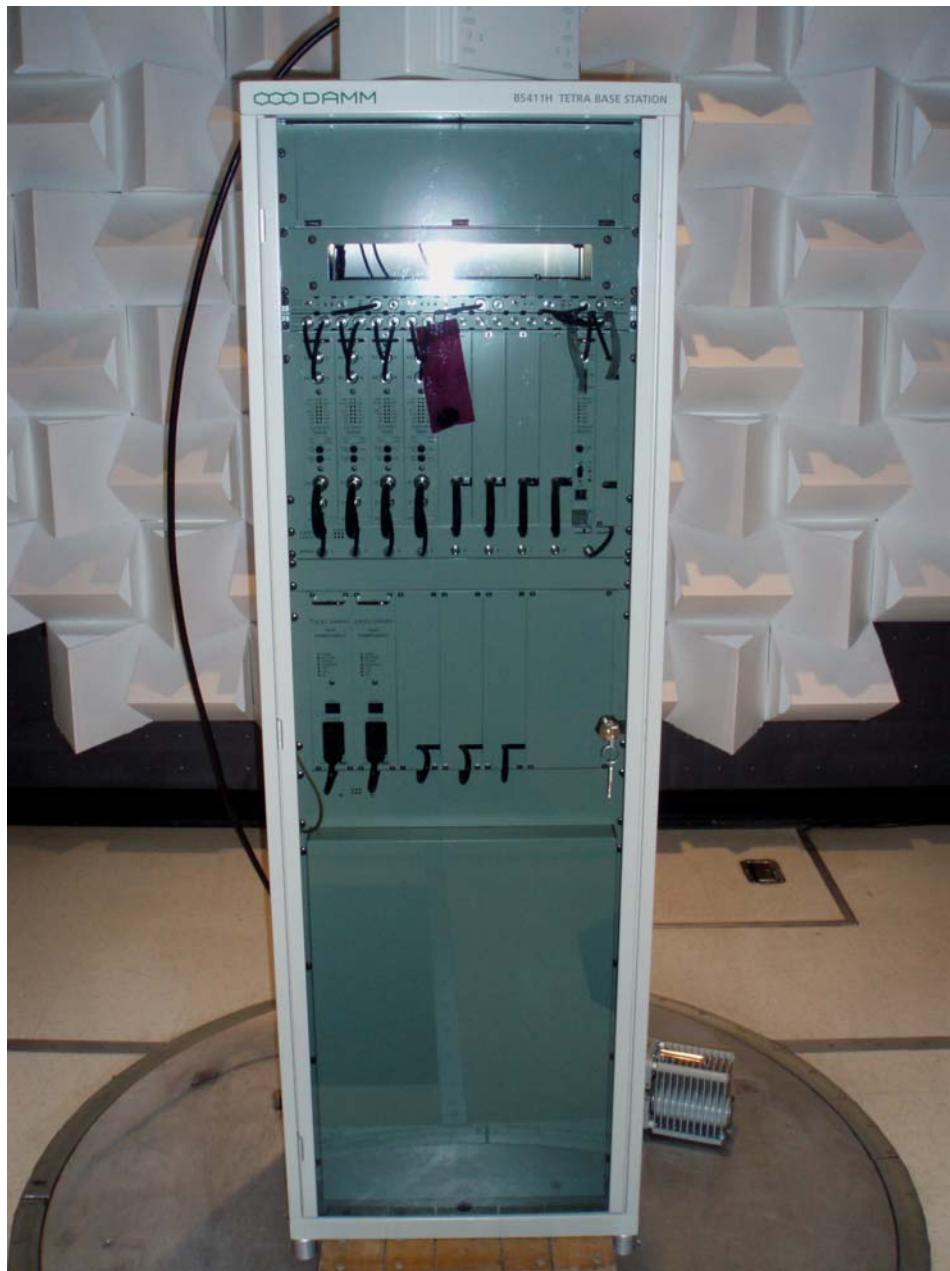

Applicant: DAMM CELLULAR SYSTEMS A/S
FCC ID: Z5W-104018
IC CERT #: 10159A-104018
Report: D\DAMM\2916MT11\2916MT11TestReport.doc

GENERAL INFORMATION (cont'd)
DUT Specification

TR-412 Transceiver



Applicant: DAMM CELLULAR SYSTEMS A/S
FCC ID: Z5W-104018
IC CERT #: 10159A-104018
Report: D\DAMM\2916MT11\2916MT11TestReport.doc

TEST PROCEDURES

Power Line Conducted Interference: The procedure used was ANSI/TIA 603-C: 2004 using a 50uH LISN. Both lines were observed with the DUT transmitting. The bandwidth of the spectrum analyzer was 10 kHz with an appropriate sweep speed.

Bandwidth 20 dB: The measurements were made with the spectrum analyzer's resolution bandwidth (RBW) = 1 MHz and the video bandwidth (VBW) = 3 MHz and the span set as shown on plot.

Power Output: The RF power output was measured at the antenna feed point using a peak power meter.

Antenna Conducted Emissions: The RBW = 100 kHz, VBW = 300 kHz and the span set to 10 MHz and the spectrum was scanned from 30 MHz to the 10th harmonic of the fundamental. Above 1 GHz the resolution bandwidth was 1 MHz and the VBW = 3 MHz and the span to 50 MHz.

Radiation Interference: The test procedure used was ANSI/TIA 603-C: 2004 using an Agilent spectrum receiver with pre-selector. The bandwidth (RBW) of the spectrum receiver was 100 kHz up to 1 GHz and 1 MHz above 1 GHz with an appropriate sweep speed. The VBW above 1 GHz was 3 MHz. The analyzer was calibrated in dB above a micro volt at the output of the antenna.

Applicant: DAMM CELLULAR SYSTEMS A/S
FCC ID: Z5W-104018
IC CERT #: 10159A-104018
Report: D\DAMM\2916MT11\2916MT11TestReport.doc

RF POWER OUTPUT

Rule Part No.: FCC Part 2.1046(a), IC RSS-119 4.1 and 5.4, RSS-GEN 4.8

Test Requirements:

Method of Measurement: RF power is measured by connecting a 50-ohm, resistive wattmeter to the RF output connector. With a nominal battery voltage and the transmitter properly adjusted the RF output measures:

Test Setup Diagram:

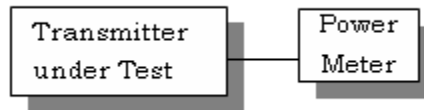

Test Data:

At output of TR-412H module:

OUTPUT POWER: HIGH – 25
LOW – 2.5

As configured at RF output connector of system:

OUTPUT POWER: HIGH – 12
LOW - 1.5

Part 2.1033 (C)(8) DC Input into the final amplifier

INPUT POWER: $(26.0V)(3.5A) = 91.0$ Watts

Applicant: DAMM CELLULAR SYSTEMS A/S
FCC ID: Z5W-104018
IC CERT #: 10159A-104018
Report: D\DAMM\2916MT11\2916MT11TestReport.doc

MODULATION CHARACTERISTICS

Part 2.1033(c)

Part 2.1033(c) (4)

FCC Part 90.209, IC RSS-119 5.5

FCC Part 90.207

Type of Emission: $\pi/4$ DQPSK TETRA as defined in EN 300 392-2.

TETRA is a digital, trunked radio technology that operates with Time Division Multiple Access (TDMA) in four-slot channels within a twenty-five kilohertz bandwidth.

This unit has two distinct and different but similar modulation schemes. One being as defined above and the second mode which is similar and implemented through a software change only where:

Description of the modified modulation:

From ETSI EN 300 392-2 part 5.5 the requirement for the output spectrum of a TETRA signal $G(f)$ is:

$$\begin{array}{ll}
 G(f) = 1 & \text{for } |f| \leq (1 - \alpha)/2T \\
 G(f) = \sqrt{0.5(1 - \sin(\pi(2|f|T - 1)/2\alpha))} & \text{for } (1 - \alpha)/2T \leq |f| \leq (1 + \alpha)/2T \\
 G(f) = 0 & \text{for } |f| \geq (1 + \alpha)/2T
 \end{array}$$

Where α is the roll-off factor, which determines the width of the transmission band at a given symbol rate. For TETRA the value of α shall be 0.35.

This spectrum can't fulfill the requirement of the FCC. Therefore the shape of the output spectrum has been modified by changing α from 0.35 to 0.20. This gives a narrowed spectrum that meets the FCC requirements for the 20 kHz bandwidth.

The TETRA and modified modulation meets the spectrum efficiency requirements of Part 90.

AUDIO FREQUENCY RESPONSE

Rule Part No.: FCC Part 2.1047(a)(b), IC RSS-119 5.2

Test Requirements:

Method of Measurement:

The audio frequency response was measured in accordance with ANSI/TIA 603-C: 2004. A curve or equivalent data showing the frequency response of the audio modulating circuit over a range of 100 – 5000Hz shall be submitted. The audio frequency response curve is shown below.

AUDIO FREQUENCY RESPONSE PLOT

Digitally encoded voice

AUDIO LOW PASS FILTER

VOICE MODULATED COMMUNICATION EQUIPMENT

Part 2.1047(a) Voice modulated communication equipment: For equipment required to have an audio low-pass filter, a curve showing the frequency response of the filter, or of all the circuitry installed between the modulation limiter and the modulated stage shall be submitted.

AUDIO LOW PASS FILTER

Digitally encoded voice

AUDIO INPUT VERSUS MODULATION

Rule Part No.: FCC Part 2.1047(b) & 90, IC RSS-119 5.2

Test Requirements:

Method of Measurement: **Modulation cannot exceed 100%**, The audio input level needed for a particular percentage of modulation was measured in accordance with ANSI/TIA 603-C:2004. The audio input curves versus modulation are shown below. Curves are provided for audio input frequencies of 300, 1000, and 2500 Hz.

MODULATION LIMITING PLOT

Employs digitally encoded voice

Applicant: DAMM CELLULAR SYSTEMS A/S
FCC ID: Z5W-104018
IC CERT #: 10159A-104018
Report: D\DAMM\2916MT11\2916MT11TestReport.doc

OCCUPIED BANDWIDTH

**FCC Part 2.1049(c), RSS-GEN 4.6 EMISSION BANDWIDTH
FCC Part 90.210(b) RSS-119 4.2 25 kHz Channel Spacing**

Data in the plots show that on any frequency removed from the assigned frequency by more than 50%, but not more than 100%: At least 25dB. On any frequency removed from the assigned frequency by more than 100%, but not more than 250%: At least 35 dB. On any frequency removed from the assigned frequency by more than 250%, of the authorized bandwidth: At least 43 + 10log(P)dB.

Part 90.210(c) 25 kHz Channel Spacing Not Equipped with a Low Pass Filter

For transmitters that are not equipped with an audio low pass filter pursuant to S90.211 (b), the power of any emission must be attenuated below the un-modulated carrier output power as follows; (1) On any frequency removed from the center of the authorized bandwidth by a displacement frequency (fd in kHz) of more than 5 kHz but not more than 10 kHz: At least 83 log (fd/5) dB; (2) ON any frequency removed from the center of the authorized bandwidth by a displacement frequency (fd in kHz) of more than 10 kHz, but not more than 250% of the authorized bandwidth: At least 29 log(fd2/11)dB or 50 dB, whichever is the lesser attenuation; (3) On any frequency removed from the center of the authorized bandwidth by more than 250% of the authorized bandwidth: At least 43+10 log(Po)dB.

OCCUPIED BANDWIDTH MEASUREMENT

Test procedure: ANSI/TIA-603-C:2004 para 2.2.11.

Test Setup Diagram:

OCCUPIED BANDWIDTH MEASUREMENT

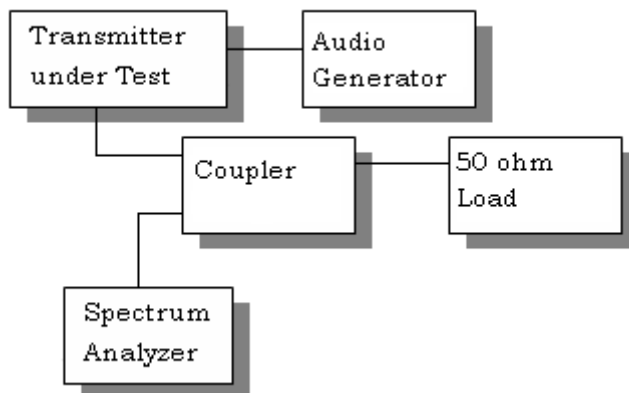

Test Data: See the plots below

Applicant: DAMM CELLULAR SYSTEMS A/S
 FCC ID: Z5W-104018
 IC CERT #: 10159A-104018
 Report: D\DAMM\2916MT11\2916MT11TestReport.doc

**25 kHz Digital
0.2 modified
Mask B**

NOTES:

FCC 90.210 Mask B

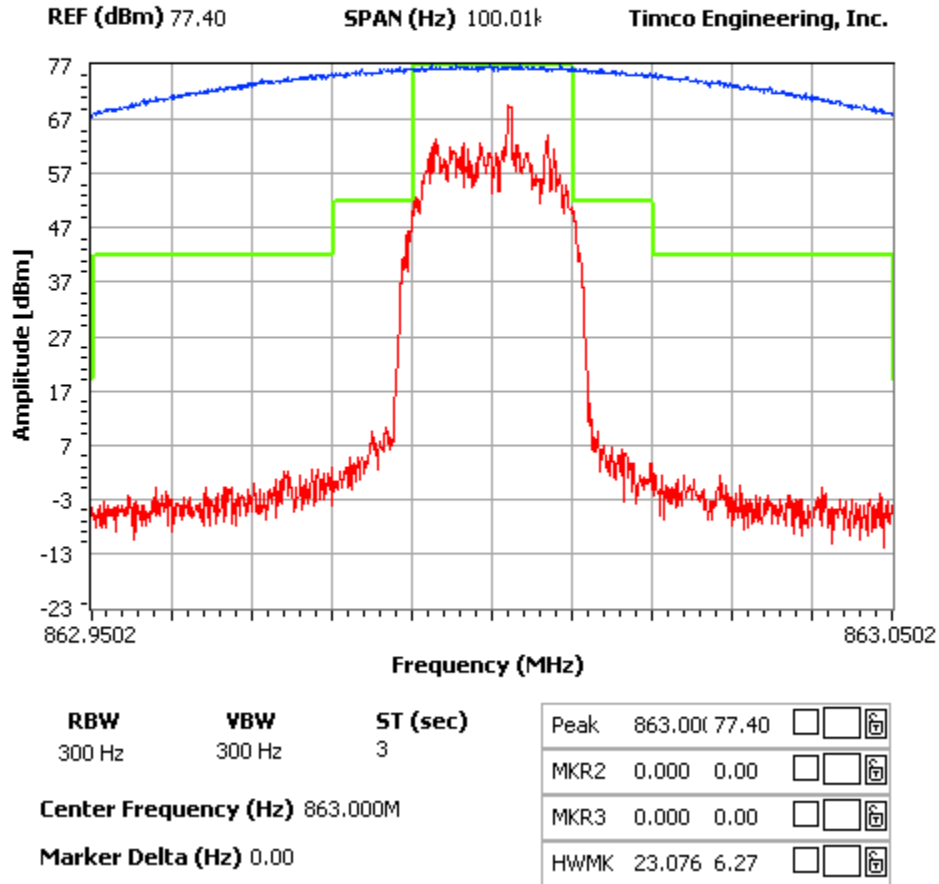

Applicant: DAMM CELLULAR SYSTEMS A/S
 FCC ID: Z5W-104018
 IC CERT #: 10159A-104018
 Report: D\DAMM\2916MT11\2916MT11TestReport.doc

**25.0 kHz – DIGITAL
0.2 modified**

NOTES:

FCC 90.210 Mask G

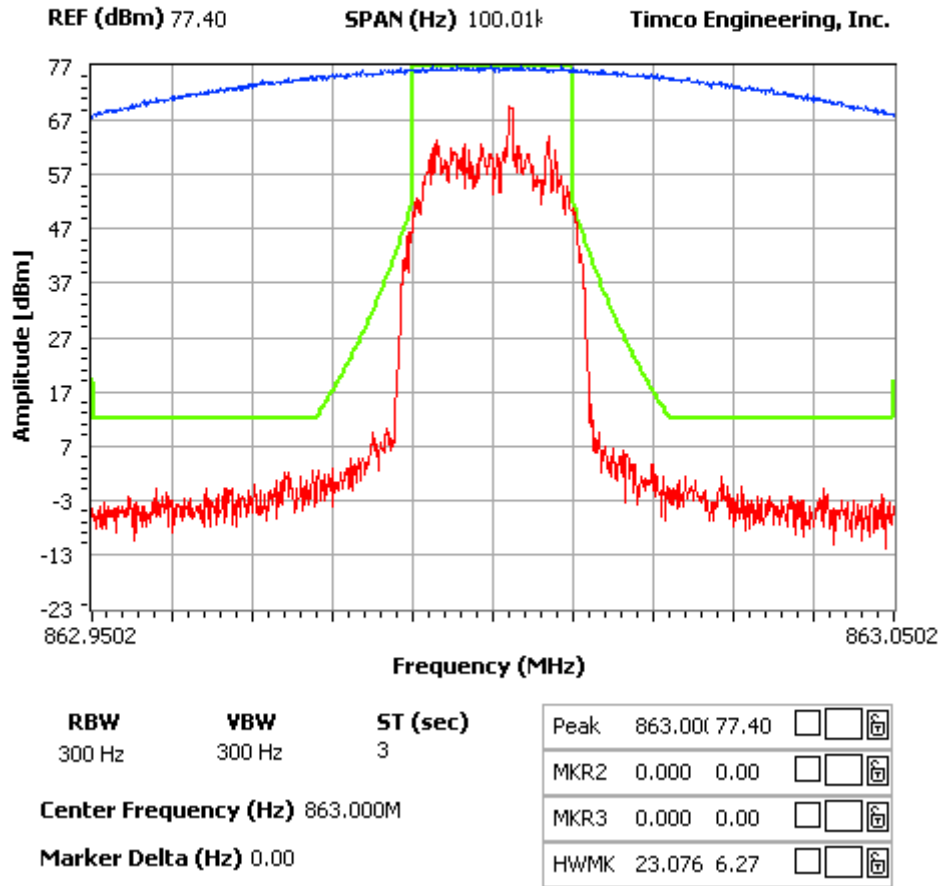

Applicant: DAMM CELLULAR SYSTEMS A/S
 FCC ID: Z5W-104018
 IC CERT #: 10159A-104018
 Report: D\DAMM\2916MT11\2916MT11TestReport.doc

**25 kHz Digital
0.20 modified
Mask EA**

NOTES:

FCC 90.691 Mask

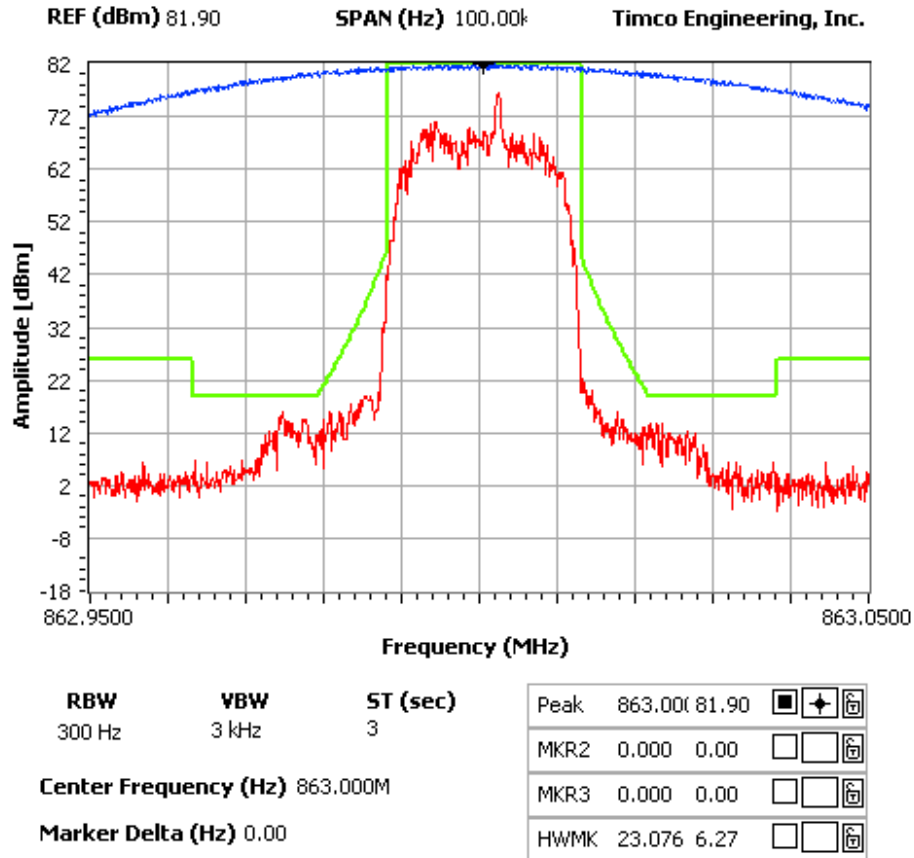

Applicant: DAMM CELLULAR SYSTEMS A/S
 FCC ID: Z5W-104018
 IC CERT #: 10159A-104018
 Report: D\DAMM\2916MT11\2916MT11TestReport.doc

ADJACENT CHANNEL POWER PLOTS 0.35 TETRA (conventional)

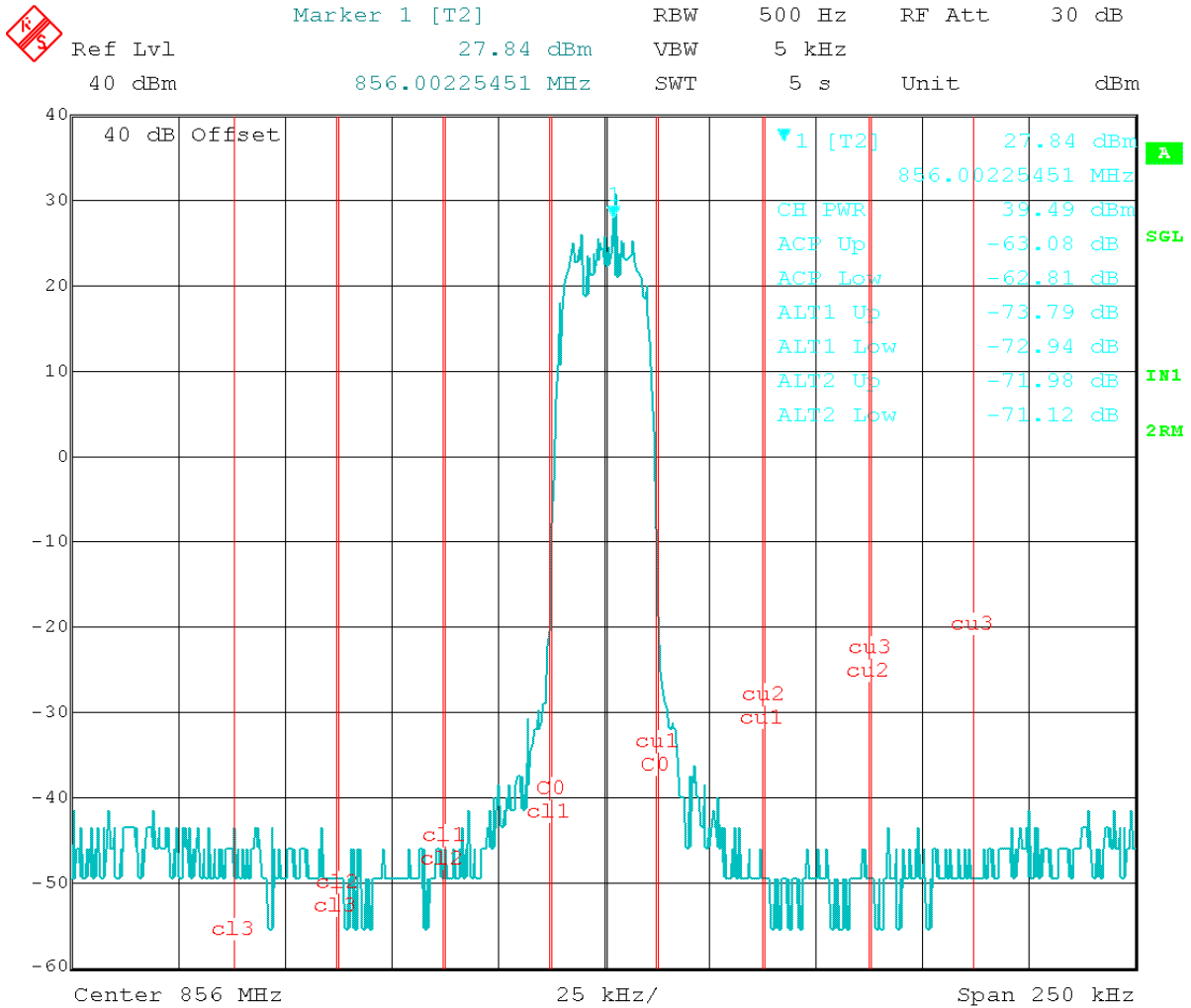

Date: 16.JAN.2012 14:16:00

Applicant: DAMM CELLULAR SYSTEMS A/S
 FCC ID: Z5W-104018
 IC CERT #: 10159A-104018
 Report: D\DAMM\2916MT11\2916MT11TestReport.doc

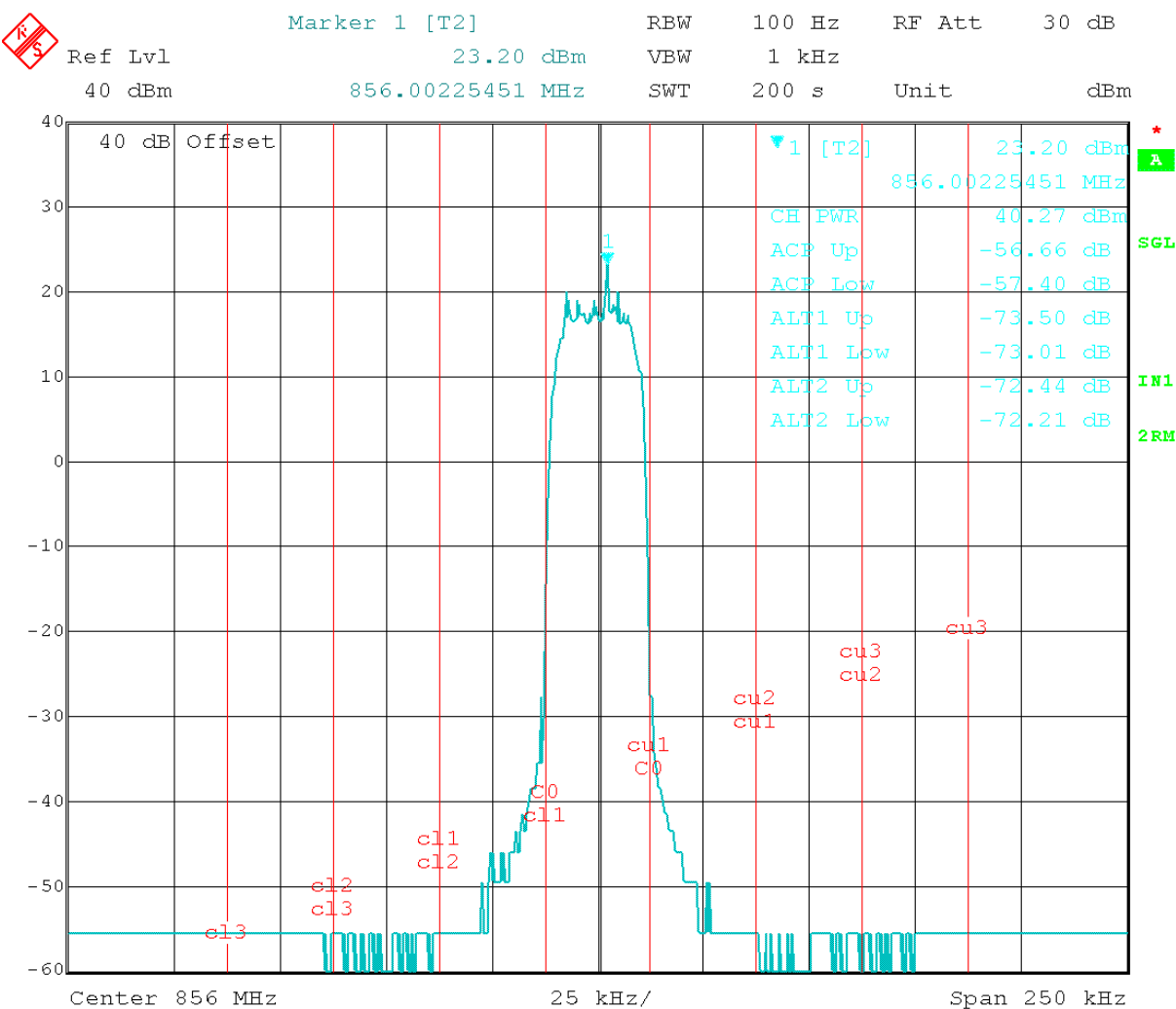

Date: 16.JAN.2012 14:07:25

Applicant: DAMM CELLULAR SYSTEMS A/S
 FCC ID: Z5W-104018
 IC CERT #: 10159A-104018
 Report: D\DAMM\2916MT11\2916MT11TestReport.doc

SPURIOUS EMISSIONS AT ANTENNA TERMINALS (CONDUCTED)

Rule Part No.: FCC Part 2.1051(a), RSS-GEN 7.1.4

Requirements: 25 kHz Channel Spacing = 58.0 dBc (for 32 Watts)

Method of Measurement: The carrier was modulated 100% using a 2500 Hz tone. The spectrum was scanned from 0.4 to at least the 10th harmonic of the fundamental. The measurements were made in accordance with standard ANSI/TIA 603-C: 2004.

Test Data:

TF HIGH POWER	EF	dB below carrier		TF LOW POWER	EF	dB below carrier
856	856	0		856	856	0
	1712	114.1			1712	100.8
	2568	102.9			2568	105.5
	3424	111.6			3424	106.9
	4280	114.3			4280	104.7
	5136	122.8			5136	109.7
	5992	122.4			5992	109.3
	6848	122			6848	105.6
	7704	120.3			7704	105.2
	8560	120.7			8560	105.4

TF HIGH POWER	EF	dB below carrier		TF LOW POWER	EF	dB below carrier
863	863	0		863	863	0
	1726	109			1726	98.8
	2589	110.8			2589	102.9
	3452	112.7			3452	105
	4315	114.7			4315	103.4
	5178	120.1			5178	106.8
	6041	120			6041	108.6
	6904	119.6			6904	105.8
	7767	119.2			7767	105.2
	8630	117.9			8630	103.6

Applicant: DAMM CELLULAR SYSTEMS A/S
 FCC ID: Z5W-104018
 IC CERT #: 10159A-104018
 Report: D\DAMM\2916MT11\2916MT11TestReport.doc

TF HIGH POWER	EF	dB below carrier		TF LOW POWER	EF	dB below carrier
870	869	0		870	869	0
	1738	111			1738	100
	2607	109.3			2607	106.4
	3476	104.8			3476	107.9
	4345	118.7			4345	106.4
	5214	122.6			5214	108.3
	6083	122.8			6083	108.8
	6952	123.1			6952	109.3
	7821	120.9			7821	107.2
	8690	121.2			8690	108.5

Method of Measuring Conducted Spurious Emissions

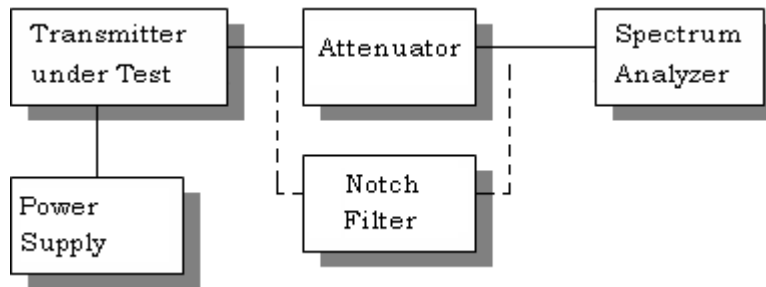

METHOD OF MEASUREMENT: The procedure used was ANSI/TIA 603-C: 2004.

FIELD STRENGTH OF SPURIOUS EMISSIONS

Rule Parts. No.: FCC Part 2.1053, RSS-GEN 4.9

Requirements: The FCC limits for radiated emissions are the same as previously stated for the conducted emissions.

METHOD OF MEASUREMENT: The tabulated data shows the results of the radiated field strength emissions test. The spectrum was scanned from 30 MHz to at least the tenth harmonic of the fundamental. This test was conducted per ANSI/TIA 603-C: 2004 using the substitution method. Measurements were made at the test site of TIMCO ENGINEERING, INC. located at 849 NW State Road 45, Newberry, FL 32669.

Test Setup Diagram:

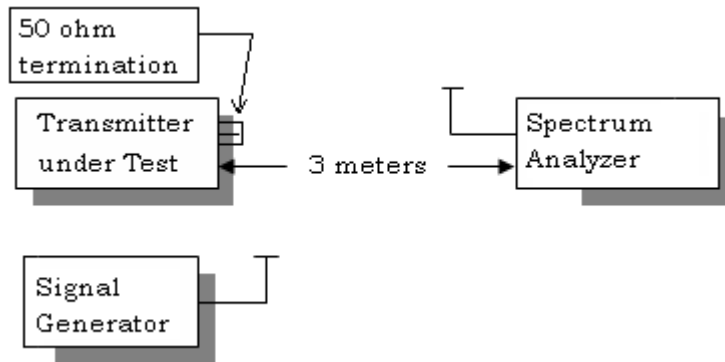

Test Data:

High Power

Emission Frequency MHz	Ant. Polarity	dB Below Carrier (dBc)
856.00	H	0
1712.00	H	78.0
2568.00	H	90.5
3424.00	H	90.0
4280.00	H	91.2

Low Power

Emission Frequency MHz	Ant. Polarity	dB Below Carrier (dBc)
856.00	H	0
1712.00	H	81.2
4280.00	H	81.3

High Power

Emission Frequency MHz	Ant. Polarity	dB Below Carrier (dBc)
863.00	H	0
1726.00	H	77.6
2589.00	H	91.0
3452.00	V	87.4
4315.00	H	90.8

Low Power

Emission Frequency MHz	Ant. Polarity	dB Below Carrier (dBc)
863.00	H	0
1726.00	H	82.1
4315.00	H	81.7

HIGH POWER

Emission Frequency MHz	Ant. Polarity	dB Below Carrier (dBc)
869.00	H	0
1738.00	H	85.5
2607.00	H	90.0
3476.00	H	89.0
4345.00	V	86.1

LOW POWER

Emission Frequency MHz	Ant. Polarity	dB Below Carrier (dBc)
869.00	H	0
1738.00	H	81.5
4345.00	H	80.9

Applicant: DAMM CELLULAR SYSTEMS A/S
 FCC ID: Z5W-104018
 IC CERT #: 10159A-104018
 Report: D\DAMM\2916MT11\2916MT11TestReport.doc

TRANSIENT FREQUENCY BEHAVIOR

FCC Part 2.1055(a)(1)

FCC Part 90.214, IC RSS-119 5.8

REQUIREMENTS: Transmitters designed to operate in the 150-174 MHz and 421-512 MHz frequency bands must maintain transient frequencies within the maximum transient frequencies within the maximum frequency difference limits during the time intervals indicated:

Time Intervals	Maximum frequency difference	All Equipment	
		150-174 MHz	421-512 MHz

Transient Frequency Behavior for Equipment Designed to Operate on 25 kHz Channels

t ₁ ⁴	±25.0 kHz	5.0 ms	10.0 ms
t ₂	±12.5 kHz	20.0 ms	25.0 ms
t ₃ ⁴	±25.0 kHz	5.0 ms	10.0 ms

Transient Frequency Behavior for Equipment Designed to Operate on 12.5 kHz Channels

t ₁ ⁴	±12.5 kHz	5.0 ms	10.0 ms
t ₂	±6.25 kHz	20.0 ms	25.0 ms
t ₃ ⁴	±12.5 kHz	5.0 ms	10.0 ms

Transient Frequency Behavior for Equipment Designed to Operate on 6.25 kHz Channels

t ₁ ⁴	±6.25 kHz	5.0 ms	10.0 ms
t ₂	±3.125 kHz	20.0 ms	25.0 ms
t ₃ ⁴	±6.25 kHz	5.0 ms	10.0 ms

Not required for this band.

TEST PROCEDURE: ANSI/TIA 603-C: 2004 PARA 2.2.19

1. Using the variable attenuator the transmitter level was set to 40 dB below the test receivers maximum input level, then the transmitter was turned off.
2. With the transmitter off the signal generator was set 20dB below the level of the transmitter in the above step, this level will be maintained with the signal generator through-out the test.
3. Reduce the attenuation between the transmitter and the RF detector by 30 dB. With the levels set as above the transient frequency behavior was observed & recorded.

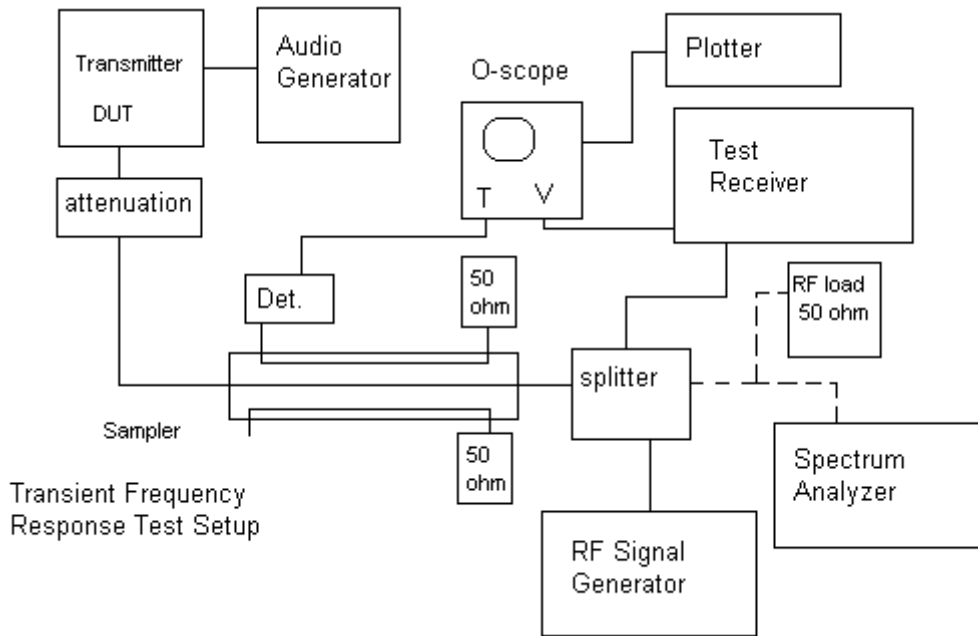

EMC EQUIPMENT LIST

Device	Manufacturer	Model	Serial Number	Cal/Char Date	Due Date
3-Meter Semi-Anechoic Chamber	Panashield	N/A	N/A	Listed 5/10/10	5/10/12
AC Voltmeter	HP	400FL	2213A14499	CAL 6/12/11	6/12/13
Antenna: Active Loop	ETS-Lindgren	6502	00062529	CAL 9/23/10	9/23/12
Frequency Counter	HP	5385A	2730A03025	CAL 8/17/11	8/17/13
Hygro-Thermometer	Extech	445703	0602	CAL 6/15/11	6/15/13
Modulation Analyzer	HP	8901A	3435A06868	CAL 7/18/11	7/18/13
Digital Multimeter	Fluke	FLUKE-77	35053830	CAL 9/9/11	9/9/13
Analyzer Tan Tower Preamplifier	HP	8449B-H02	3008A00372	CAL 10/28/11	10/28/13
Analyzer Tan Tower Quasi-Peak Adapter	HP	85650A	3303A01690	CAL 10/28/11	10/28/13
Analyzer Tan Tower RF Preselector	HP	85685A	3221A01400	CAL 10/28/11	10/28/13
Analyzer Tan Tower Spectrum Analyzer	HP	8566B Opt 462	3138A07786 3144A20661	CAL 10/28/11	10/28/13
Temperature Chamber	Tenney Engineering	TTRC	11717-7	CHAR 4/25/10	4/25/12
Antenna	ETS	3117	41534	9/22/2010	9/22/2012
Antenna	Electro metrics	LPA-25	1122	5/04/2011	5/04/2013
Antenna	Electro metrics	BIA-25	1171	1/15/2010	1/15/2012

Applicant: DAMM CELLULAR SYSTEMS A/S
 FCC ID: Z5W-104018
 IC CERT #: 10159A-104018
 Report: D\DAMM\2916MT11\2916MT11TestReport.doc



Damm Cellular Systems A/S, Denmark

Doc. No.

Rev.

Date

0

2012-01-19

BS41x FREQUENCY STABILITY

FREQUENCY STABILITY

Date: 2012-01-19

Operator: Morten Christensen, Dev. Engineer

Rule Parts. No.: FCC Part 2.1055, Part 90.213, RSS-119 5.3, RSS-GEN 7.2.4

Requirements: Temperature range requirements: -30 to +50° C.
Voltage Variation +, -15%
±1.5 PPM

Method of Measurements: ANSI/TIA 603-C: 2004

Equipment: Damm BS41x
BSC412 SN: 10001798
TR412 SN: 09000260

Meas. Equipment: Freq. Meas. Stabilock 4040 SN: 1625043
Climate Chamber CoolTec II SN: P1083

Test Data:

Ref Frequency: 865.0000Mhz

Assigned Frequency (Ref. Frequency) (MHz)		
Temperature (°C)	Frequency (MHz)	Frequency Stability (PPM)
-30	865.000012	+0.014
-20	865.000010	+0.012
-10	865.000010	+0.012
0	865.000006	+0.007
+10	865.000004	+0.005
+20	865.000002	+0.002
+30	865.000002	+0.002
+40	865.000000	+0.000
+50	865.000000	+0.000